



THE DATASHEET OF ESP32-S2-SOLO-N4R2



ESP32-S2-SOLO

ESP32-S2-SOLO-U

Datasheet

2.4 GHz Wi-Fi (802.11 b/g/n) module

Built around ESP32-S2 series of SoC, Xtensa® single-core 32-bit LX7 microprocessor

Flash up to 16 MB, optional 2 MB PSRAM in chip package

36 GPIOs, rich set of peripherals

On-board PCB antenna or external antenna connector



ESP32-S2-SOLO



ESP32-S2-SOLO-U



Version 1.7
Espressif Systems
Copyright © 2024

1 Module Overview

Note:

Check the link or the QR code to make sure that you use the latest version of this document:
https://www.espressif.com/documentation/esp32-s2-solo_esp32-s2-solo-u_datasheet_en.pdf



1.1 Features

CPU and On-Chip Memory

- ESP32-S2 or ESP32-S2R2 embedded, Xtensa® single-core 32-bit LX7 microprocessor, up to 240 MHz
- 128 KB ROM
- 320 KB SRAM
- 16 KB SRAM in RTC
- 2 MB embedded PSRAM (ESP32-S2R2 only)

Wi-Fi

- 802.11 b/g/n
- Bit rate: 802.11n up to 150 Mbps
- A-MPDU and A-MSDU aggregation
- 0.4 μ s guard interval support
- Operating frequency: 2412 ~ 2484 MHz

Peripherals

- GPIO, SPI, LCD, UART, I2C, I2S, Camera interface, IR, pulse counter, LED PWM, TWAI® (compatible with ISO 11898-1, i.e. CAN Specification 2.0), full-speed USB OTG, ADC, DAC, touch sensor, temperature sensor

Note:

* Please refer to [ESP32-S2 Series Datasheet](#) for detailed information about the module peripherals.

Integrated Components on Module

- 40 MHz crystal oscillator
- 4 MB SPI flash

Antenna Options

- On-board PCB antenna (ESP32-S2-SOLO)
- External antenna via a connector (ESP32-S2-SOLO-U)

Operating Conditions

- Operating voltage/Power supply: 3.0 ~ 3.6 V
- Operating ambient temperature:
 - 85 °C version: -40 ~ 85 °C
 - 105 °C version: -40 ~ 105 °C (ESP32-S2-SOLO-H4 and ESP32-S2-SOLO-U-H4 only)

Certification

- RF certification: See [certificates](#)
- Green certification: RoHS/REACH

Test

- HTOL/HTSL/uHAST/TCT/ESD

1.2 Description

ESP32-S2-SOLO and ESP32-S2-SOLO-U are two powerful, generic Wi-Fi MCU modules that have a rich set of peripherals. They are an ideal choice for a wide variety of application scenarios relating to Internet of Things (IoT), wearable electronics, and smart home.

ESP32-S2-SOLO comes with a PCB antenna (ANT). ESP32-S2-SOLO-U comes with an external antenna connector (CONN). A wide selection of module variants are available for customers as shown in Table 1 and Table 2.

Table 1: ESP32-S2-SOLO (ANT) Series Comparison¹

Ordering Code	Flash ²	PSRAM ³	Chip Embedded	Ambient Temp. ⁴ (°C)	Size ⁵ (mm)
ESP32-S2-SOLO-N4 (NRND)	4 MB (Quad SPI)	—	ESP32-S2	-40 ~ 85	18.0 × 25.5 × 3.1
ESP32-S2-SOLO-H4 (End of life)		—		-40 ~ 105	
ESP32-S2-SOLO-N4R2 (NRND)		2 MB (Quad SPI)	ESP32-S2R2	-40 ~ 85	

¹ This table shares the same notes presented in Table 2 below.

Table 2: ESP32-S2-SOLO-U (CONN) Series Comparison

Ordering Code	Flash ²	PSRAM ³	Chip Embedded	Ambient Temp. ⁴ (°C)	Size ⁵ (mm)
ESP32-S2-SOLO-U-N4 (NRND)	4 MB (Quad SPI)	—	ESP32-S2	-40 ~ 85	18.0 × 19.2 × 3.2
ESP32-S2-SOLO-U-H4 (End of life)		—		-40 ~ 105	
ESP32-S2-SOLO-U-N4R2 (NRND)		2 MB (Quad SPI) ⁴	ESP32-S2R2	-40 ~ 85	

² All modules can be equipped with 8 MB or 16 MB flash. For details, please contact our sales team.

³ The PSRAM is integrated in the chip's package.

⁴ Ambient temperature specifies the recommended temperature range of the environment immediately outside the Espressif module.

⁵ For details, refer to Section [7.1 Physical Dimensions](#).

In this datasheet, unless otherwise stated, ESP32-S2-SOLO refers to all variants of ESP32-S2-SOLO, whereas ESP32-S2-SOLO-U refers to all variants of ESP32-S2-SOLO-U.

The ESP32-S2 chip and the ESP32-S2R2 chip at the core of the two modules fall into the same category, namely ESP32-S2 series. ESP32-S2 series of chips have an Xtensa® 32-bit LX7 CPU that operates at up to 240 MHz. It has a low-power co-processor that can be used instead of the CPU to save power while performing tasks that do not require much computing power, such as monitoring of peripherals.

ESP32-S2 series of chips integrate a rich set of peripherals, ranging from SPI, I2S, UART, I2C, LED PWM, TWAI®, LCD, Camera interface, ADC, DAC, touch sensor, temperature sensor, as well as up to 43 GPIOs. It also includes a full-speed USB On-The-Go (OTG) interface for USB communication.

1.3 Applications

- Generic Low-power IoT Sensor Hub
- Generic Low-power IoT Data Loggers
- Cameras for Video Streaming
- Over-the-top (OTT) Devices
- USB Devices
- Speech Recognition
- Image Recognition
- Mesh Network
- Home Automation
- Smart Home Control Panel
- Smart Building
- Industrial Automation
- Smart Agriculture
- Audio Applications
- Health Care Applications
- Wi-Fi-enabled Toys
- Wearable Electronics
- Retail & Catering Applications
- Smart POS Machines

Contents

1	Module Overview	2
1.1	Features	2
1.2	Description	3
1.3	Applications	4
2	Block Diagram	9
3	Pin Definitions	10
3.1	Pin Layout	10
3.2	Pin Description	10
3.3	Strapping Pins	12
3.3.1	Chip Boot Mode Control	13
3.3.2	VDD_SPI Voltage Control	13
3.3.3	ROM Messages Printing Control	14
4	Electrical Characteristics	15
4.1	Absolute Maximum Ratings	15
4.2	Recommended Operating Conditions	15
4.3	DC Characteristics (3.3 V, 25 °C)	15
4.4	Current Consumption Characteristics	16
4.4.1	Power Consumption in Active Mode	16
4.4.2	Current Consumption in Other Modes	16
4.5	Wi-Fi RF Characteristics	17
4.5.1	Wi-Fi RF Standards	17
4.5.2	Transmitter Characteristics	18
4.5.3	Receiver Characteristics	18
5	Module Schematics	21
6	Peripheral Schematics	23
7	Physical Dimensions and PCB Land Pattern	24
7.1	Physical Dimensions	24
7.2	Recommended PCB Land Pattern	25
7.3	Dimensions of External Antenna Connector	27
8	Product Handling	28
8.1	Storage Conditions	28
8.2	Electrostatic Discharge (ESD)	28
8.3	Soldering Profile	28
8.3.1	Reflow Profile	28
8.4	Ultrasonic Vibration	29

9	MAC Addresses and eFuse	30
	Related Documentation and Resources	31
	Revision History	32

List of Tables

1	ESP32-S2-SOLO (ANT) Series Comparison ¹	3
2	ESP32-S2-SOLO-U (CONN) Series Comparison	3
3	Pin Definitions	11
4	Default Configuration of Strapping Pins	12
5	Description of Timing Parameters for the Strapping Pins	13
6	Chip Boot Mode Control	13
7	VDD_SPI Voltage Control	14
8	ROM Messages Printing Control	14
9	Absolute Maximum Ratings	15
10	Recommended Operating Conditions	15
11	DC Characteristics (3.3 V, 25 °C)	15
12	Current Consumption for Wi-Fi (2.4 GHz) in Active Mode	16
13	Current Consumption in Modem-sleep Mode	16
14	Current Consumption in Low-Power Modes	17
15	Wi-Fi RF Standards	17
16	TX Power with Spectral Mask and EVM Meeting 802.11 Standards	18
17	TX EVM Test ¹	18
18	RX Sensitivity	19
19	Maximum RX Level	19
20	Adjacent Channel Rejection	20

List of Figures

1	ESP32-S2-SOLO Block Diagram	9
2	ESP32-S2-SOLO-U Block Diagram	9
3	Pin Layout (Top View)	10
4	Visualization of Timing Parameters for the Strapping Pins	13
5	ESP32-S2-SOLO Schematics	21
6	ESP32-S2-SOLO-U Schematics	22
7	Peripheral Schematics	23
8	ESP32-S2-SOLO Physical Dimensions	24
9	ESP32-S2-SOLO-U Physical Dimensions	24
10	ESP32-S2-SOLO Recommended PCB Land Pattern	25
11	ESP32-S2-SOLO-U Recommended PCB Land Pattern	26
12	Dimensions of External Antenna Connector	27
13	Reflow Profile	28

2 Block Diagram

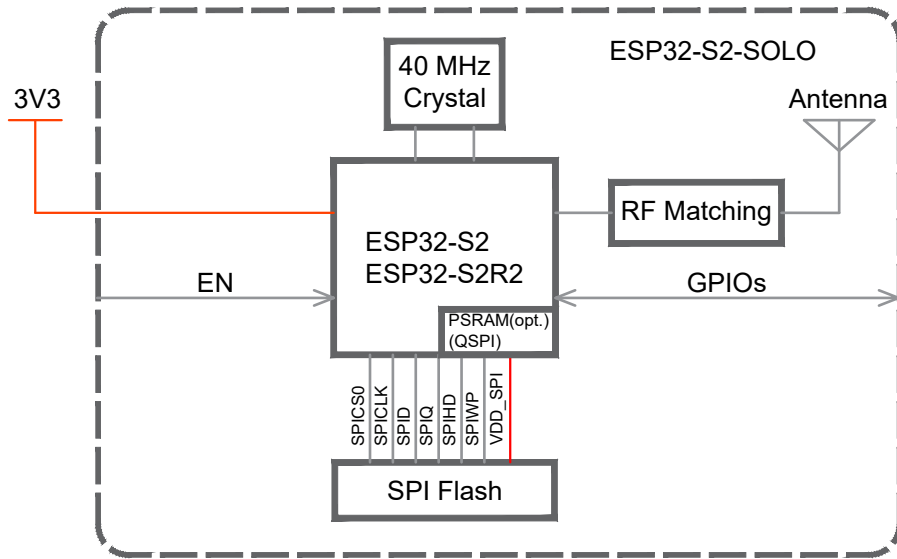

Figure 1: ESP32-S2-SOLO Block Diagram

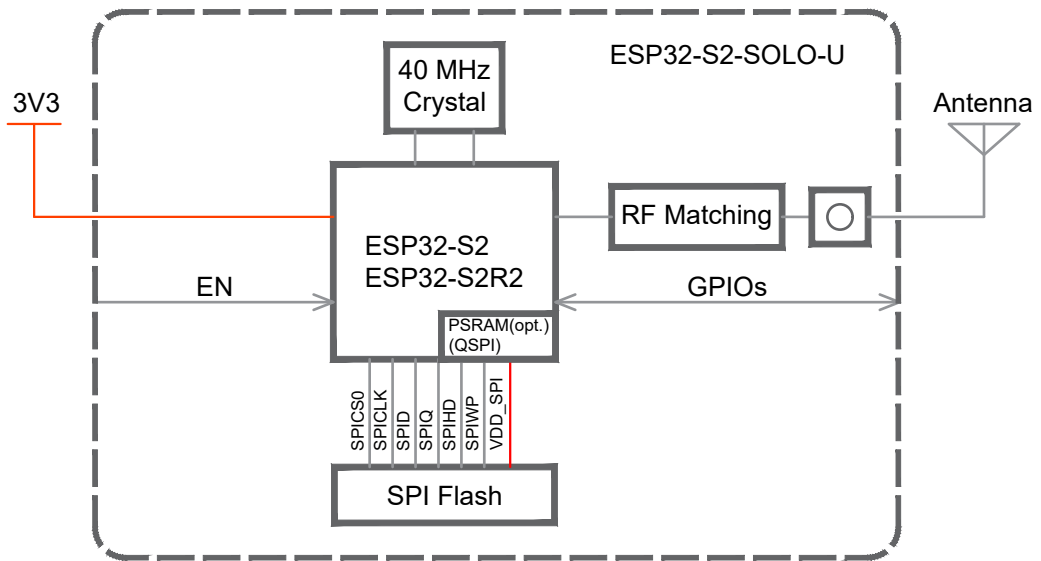

Figure 2: ESP32-S2-SOLO-U Block Diagram

3 Pin Definitions

3.1 Pin Layout

The pin diagram below shows the approximate location of pins on the module. For the actual diagram drawn to scale, please refer to Figure [7.1 Physical Dimensions](#).

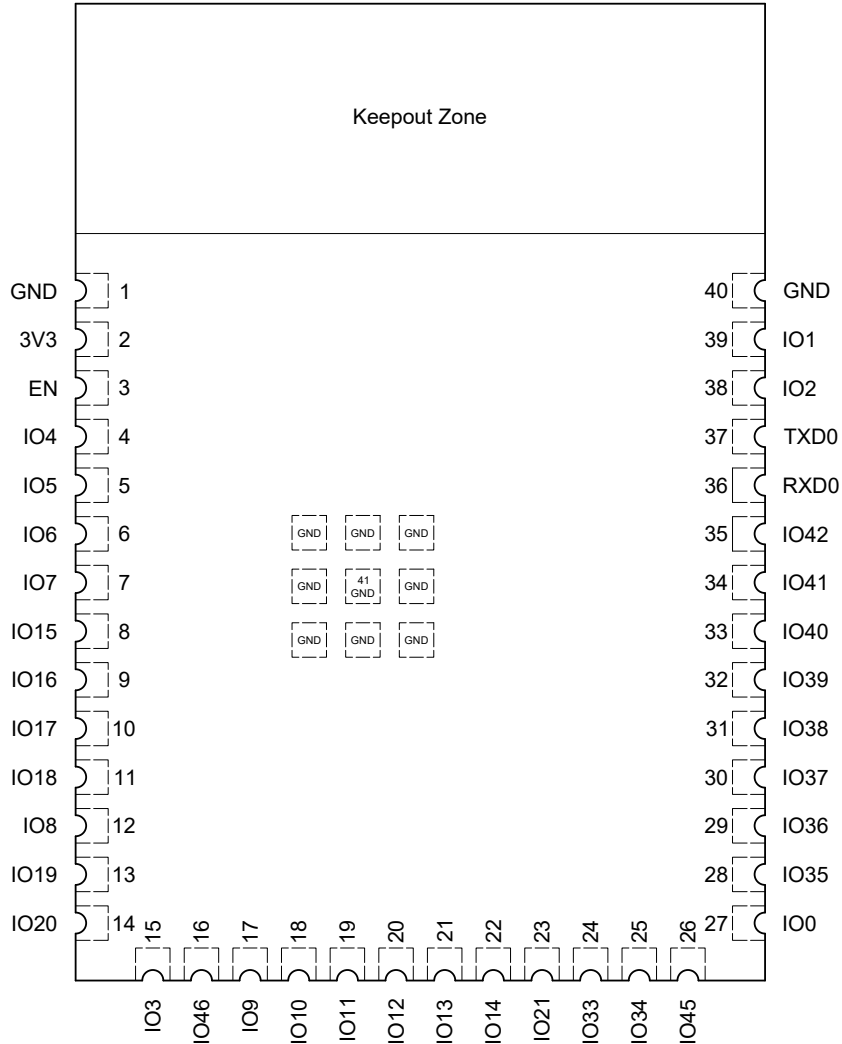

Figure 3: Pin Layout (Top View)

The above pin layout is applicable for ESP32-S2-SOLO and ESP32-S2-SOLO-U, but the latter has no keepout zone.

3.2 Pin Description

The module has 41 pins. See pin definitions in Table [3 Pin Definitions](#).

For peripheral pin configurations, please refer to [ESP32-S2 Series Datasheet](#) > Section *Peripheral Pin Configurations*.

Table 3: Pin Definitions

Name	No.	Type ¹	Function
GND	1	P	Ground
3V3	2	P	Power supply
EN	3	I	High: on, enables the chip. Low: off, the chip powers off. Note: Do not leave the EN pin floating.
IO4	4	I/O/T	RTC_GPIO4, GPIO4, TOUCH4, ADC1_CH3
IO5	5	I/O/T	RTC_GPIO5, GPIO5, TOUCH5, ADC1_CH4
IO6	6	I/O/T	RTC_GPIO6, GPIO6, TOUCH6, ADC1_CH5
IO7	7	I/O/T	RTC_GPIO7, GPIO7, TOUCH7, ADC1_CH6
IO15	8	I/O/T	RTC_GPIO15, GPIO15, UORTS, ADC2_CH4, XTAL_32K_P
IO16	9	I/O/T	RTC_GPIO16, GPIO16, UOCTS, ADC2_CH5, XTAL_32K_N
IO17	10	I/O/T	RTC_GPIO17, GPIO17, U1TXD, ADC2_CH6, DAC_1
IO18	11	I/O/T	RTC_GPIO18, GPIO18, U1RXD, ADC2_CH7, DAC_2, CLK_OUT3
IO8	12	I/O/T	RTC_GPIO8, GPIO8, TOUCH8, ADC1_CH7
IO19	13	I/O/T	RTC_GPIO19, GPIO19, U1RTS, ADC2_CH8, CLK_OUT2, USB_D-
IO20	14	I/O/T	RTC_GPIO20, GPIO20, U1CTS, ADC2_CH9, CLK_OUT1, USB_D+
IO3	15	I/O/T	RTC_GPIO3, GPIO3, TOUCH3, ADC1_CH2
IO46	16	I	GPIO46
IO9	17	I/O/T	RTC_GPIO9, GPIO9, TOUCH9, ADC1_CH8, FSPIHD
IO10	18	I/O/T	RTC_GPIO10, GPIO10, TOUCH10, ADC1_CH9, FSPICSO, FSPIIO4
IO11	19	I/O/T	RTC_GPIO11, GPIO11, TOUCH11, ADC2_CH0, FSPID, FSPIIO5
IO12	20	I/O/T	RTC_GPIO12, GPIO12, TOUCH12, ADC2_CH1, FSPICLK, FSPIIO6
IO13	21	I/O/T	RTC_GPIO13, GPIO13, TOUCH13, ADC2_CH2, FSPIQ, FSPIIO7
IO14	22	I/O/T	RTC_GPIO14, GPIO14, TOUCH14, ADC2_CH3, FSPIWP, FSPIDQS
IO21	23	I/O/T	RTC_GPIO21, GPIO21
IO33	24	I/O/T	SPIIO4, GPIO33, FSPIHD
IO34	25	I/O/T	SPIIO5, GPIO34, FSPICSO
IO45	26	I/O/T	GPIO45
IO0	27	I/O/T	RTC_GPIO0, GPIO0
IO35	28	I/O/T	SPIIO6, GPIO35, FSPID
IO36	29	I/O/T	SPIIO7, GPIO36, FSPICLK
IO37	30	I/O/T	SPIDQS, GPIO37, FSPIQ
IO38	31	I/O/T	GPIO38, FSPIWP
IO39	32	I/O/T	MTCK, GPIO39, CLK_OUT3
IO40	33	I/O/T	MTDO, GPIO40, CLK_OUT2
IO41	34	I/O/T	MTDI, GPIO41, CLK_OUT1
IO42	35	I/O/T	MTMS, GPIO42
RXD0	36	I/O/T	UORXD, GPIO44, CLK_OUT2
TXD0	37	I/O/T	UOTXD, GPIO43, CLK_OUT1
IO2	38	I/O/T	RTC_GPIO2, GPIO2, TOUCH2, ADC1_CH1
IO1	39	I/O/T	RTC_GPIO1, GPIO1, TOUCH1, ADC1_CH0

Cont'd on next page

[Not Recommended For New Designs \(NRND\)](#)

Table 3 – cont'd from previous page

Name	No.	Type ¹	Function
GND	40	P	Ground
EPAD	41	P	Ground

¹ P: power supply; I: input; O: output; T: high impedance.

3.3 Strapping Pins

Note:

The content below is excerpted from [ESP32-S2 Series Datasheet](#) > Section *Strapping Pins*. For the strapping pin mapping between the chip and modules, please refer to Chapter 5 *Module Schematics*.

At each startup or reset, a module requires some initial configuration parameters, such as in which boot mode to load the module, voltage of flash memory, etc. These parameters are passed over via the strapping pins. After reset, the strapping pins operate as regular IO pins.

The parameters controlled by the given strapping pins at module reset are as follows:

- **Chip boot mode** – GPIO0 and GPIO46
- **VDD_SPI voltage** – GPIO45
- **ROM messages printing** – GPIO46

GPIO0, GPIO45, and GPIO46 are connected to the chip's internal weak pull-up/pull-down resistors at chip reset. These resistors determine the default bit values of the strapping pins. Also, these resistors determine the bit values if the strapping pins are connected to an external high-impedance circuit.

Table 4: Default Configuration of Strapping Pins

Strapping Pin	Default Configuration	Bit Value
GPIO0	Pull-up	1
GPIO45	Pull-down	0
GPIO46	Pull-down	0

To change the bit values, the strapping pins should be connected to external pull-down/pull-up resistances. If the ESP32-S2 is used as a device by a host MCU, the strapping pin voltage levels can also be controlled by the host MCU.

All strapping pins have latches. At system reset, the latches sample the bit values of their respective strapping pins and store them until the chip is powered down or shut down. The states of latches cannot be changed in any other way. It makes the strapping pin values available during the entire chip operation, and the pins are freed up to be used as regular IO pins after reset.

Regarding the timing requirements for the strapping pins, there are such parameters as *setup time* and *hold time*. For more information, see Table 5 and Figure 4.

Table 5: Description of Timing Parameters for the Strapping Pins

Parameter	Description	Min (ms)
t_{SU}	Setup time is the time reserved for the power rails to stabilize before the CHIP_PU pin is pulled high to activate the chip.	0
t_H	Hold time is the time reserved for the chip to read the strapping pin values after CHIP_PU is already high and before these pins start operating as regular IO pins.	3

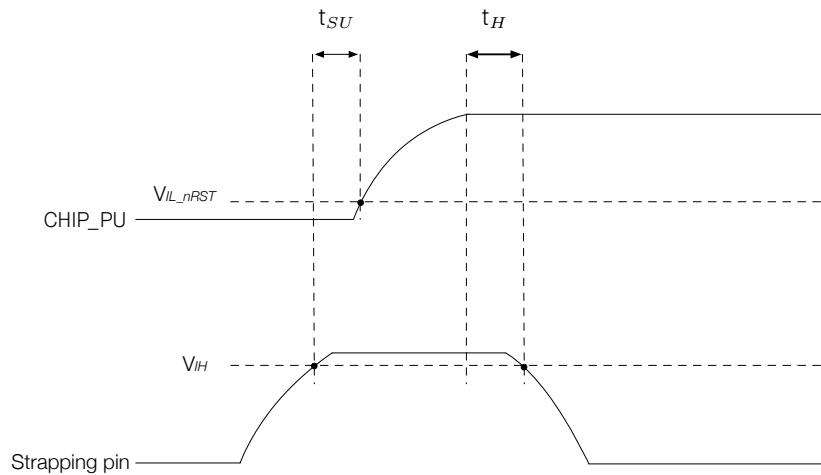

Figure 4: Visualization of Timing Parameters for the Strapping Pins

3.3.1 Chip Boot Mode Control

GPIO0 and GPIO46 control the boot mode after the reset is released. See [Table 6 Chip Boot Mode Control](#).

Table 6: Chip Boot Mode Control

Boot Mode	GPIO0	GPIO46
Default configuration	1 (Pull-up)	0 (Pull-down)
SPI Boot (default)	1	Any value
Download Boot	0	0
Invalid combination ¹	0	1

¹ This combination triggers unexpected behavior and should be avoided.

3.3.2 VDD_SPI Voltage Control

Depending on the value of EFUSE_VDD_SPI_FORCE, the voltage can be controlled in two ways.

Table 7: VDD_SPI Voltage Control

EFUSE_VDD_SPI_FORCE	GPIO45	eFuse ¹	Voltage	VDD_SPI power source ²
0	0	Ignored	3.3 V	VDD3P3_RTC_IO via R _{SPI}
	1		1.8 V	Flash Voltage Regulator
1	Ignored	0	1.8 V	Flash Voltage Regulator
		1	3.3 V	VDD3P3_RTC_IO via R _{SPI}

¹ eFuse: EFUSE_VDD_SPI_TIEH

² See [ESP32-S2 Series Datasheet](#) > Section *Power Scheme*

3.3.3 ROM Messages Printing Control

During boot process the messages by the ROM code can be printed to:

- **(Default) UOTXD pin.** For this, EFUSE_UART_PRINT_CONTROL should be 0.
- **DAC_1 pin.** For this, EFUSE_UART_PRINT_CONTROL should be 1.

EFUSE_UART_PRINT_CONTROL and GPIO46 control ROM messages printing as shown in [Table 8 ROM Messages Printing Control](#).

Table 8: ROM Messages Printing Control

eFuse ¹	GPIO46	ROM Messages Printing
0	Ignored	Always enabled
1	0	Enabled
	1	Disabled
2	0	Disabled
	1	Enabled
3	Ignored	Always disabled

¹ eFuse: EFUSE_UART_PRINT_CONTROL

4 Electrical Characteristics

4.1 Absolute Maximum Ratings

Stresses above those listed in Table 9 *Absolute Maximum Ratings* may cause permanent damage to the device. These are stress ratings only and functional operation of the device at these or any other conditions beyond those indicated under Table 10 *Recommended Operating Conditions* is not implied. Exposure to absolute-maximum-rated conditions for extended periods may affect device reliability.

Table 9: Absolute Maximum Ratings

Symbol	Parameter	Min	Max	Unit
VDD33	Power supply voltage	-0.3	3.6	V
T _{STORE}	Storage temperature	-40	105	°C

4.2 Recommended Operating Conditions

Table 10: Recommended Operating Conditions

Symbol	Parameter	Min	Typ	Max	Unit
VDD33	Power supply voltage	3.0	3.3	3.6	V
I _{VDD}	Current delivered by external power supply	0.5	—	—	A
T _A	Operating ambient temperature	85 °C version	—	85	°C
		105 °C version		105	

4.3 DC Characteristics (3.3 V, 25 °C)

Table 11: DC Characteristics (3.3 V, 25 °C)

Symbol	Parameter	Min	Typ	Max	Unit
C _{IN}	Pin capacitance	—	2	—	pF
V _{IH}	High-level input voltage	0.75 × VDD ¹	—	VDD ¹ + 0.3	V
V _{IL}	Low-level input voltage	-0.3	—	0.25 × VDD ¹	V
I _{IH}	High-level input current	—	—	50	nA
I _{IL}	Low-level input current	—	—	50	nA
V _{OH} ²	High-level output voltage	0.8 × VDD ¹	—	—	V
V _{OL} ²	Low-level output voltage	—	—	0.1 × VDD ¹	V
I _{OH}	High-level source current (VDD ¹ = 3.3 V, V _{OH} ≥ 2.64 V, PAD_DRIVER = 3)	—	40	—	mA
I _{OL}	Low-level sink current (VDD ¹ = 3.3 V, V _{OL} = 0.495 V, PAD_DRIVER = 3)	—	28	—	mA
R _{PU}	Pull-up resistor	—	45	—	kΩ
R _{PD}	Pull-down resistor	—	45	—	kΩ
V _{IH_nRST}	Chip reset release voltage	0.75 × VDD ¹	—	VDD ¹ + 0.3	V
V _{IL_nRST}	Chip reset voltage	-0.3	—	0.25 × VDD ¹	V

[Not Recommended For New Designs \(NRND\)](#)

¹ VDD is the I/O voltage for pins of a particular power domain.

² V_{OH} and V_{OL} are measured using high-impedance load.

4.4 Current Consumption Characteristics

Owing to the use of advanced power-management technologies, the module can switch between different power modes. For details on different power modes, please refer to Section *RTC and Low-Power Management* in [ESP32-S2 Series Datasheet](#) [ESP32-S2 Series Datasheet](#).

4.4.1 Power Consumption in Active Mode

Table 12: Current Consumption for Wi-Fi (2.4 GHz) in Active Mode

Work Mode	RF Condition	Description	Peak (mA)
Active (RF working)	TX	802.11b, 1 Mbps, DSSS, @19.0 dBm	320
		802.11g, 54 Mbps, OFDM, @17.5 dBm	273
		802.11n, HT20, MCS7, @17.0 dBm	265
		802.11n, HT40, MCS7, @16.0 dBm	274
	RX ²	802.11b/g/n, HT20	77
		802.11n, HT40	81

¹ The current consumption measurements are taken with a 3.3 V supply at 25 °C of ambient temperature at the RF port. All transmitters' measurements are based on 100% duty cycle.

² The current consumption figures in RX mode are for cases where the peripherals are disabled and the CPU idle.

Note:

The content below is excerpted from Section *Power Consumption in Other Modes* in [ESP32-S2 Series Datasheet](#).

4.4.2 Current Consumption in Other Modes

The measurements below are applicable to ESP32-S2, ESP32-S2FH2, and ESP32-S2FH4. Since ESP32-S2FN4R2 and ESP32-S2R2 come with in-package PSRAM, their current consumption might be higher.

Table 13: Current Consumption in Modem-sleep Mode

Mode	CPU Frequency (MHz)	Description	Typ	
			All Peripherals Clocks Disabled (mA)	All Peripherals Clocks Enabled (mA) ¹
Modem-sleep ^{2,3}	240	CPU is idle	20.0	28.0
		CPU is running	23.0	32.0
	160	CPU is idle	14.0	21.0

Cont'd on next page

[Not Recommended For New Designs \(NRND\)](#)

Table 13 – cont'd from previous page

Mode	CPU Frequency (MHz)	Description	Typ	
			All Peripherals Clocks Disabled (mA)	All Peripherals Clocks Enabled (mA) ¹
	80	CPU is running	16.0	24.0
		CPU is idle	10.5	18.4
		CPU is running	12.0	20.0

¹ In practice, the current consumption might be different depending on which peripherals are enabled.

² In Modem-sleep mode, Wi-Fi is clock gated.

³ In Modem-sleep mode, the consumption might be higher when accessing flash. For a flash rated at 80 Mbit/s, in SPI 2-line mode the consumption is 10 mA.

Table 14: Current Consumption in Low-Power Modes

Work mode	Description	Typ (μ A)	
Light-sleep ¹	VDD_SPI and Wi-Fi are powered down, and all GPIOs are high-impedance	750	
Deep-sleep	The ULP co-processor is powered on ²	ULP-FSM	170
		ULP-RISC-V	190
	ULP sensor-monitored pattern ³		22
	RTC timer + RTC memory		25
	RTC timer only		20
Power off	CHIP_PU is set to low level, the chip is powered off	1	

¹ In Light-sleep mode, with all related SPI pins pulled up, the current consumption of the embedded PSRAM is 140 μ A. Chip variants with in-package PSRAM include ESP32-S2FN4R2 and ESP32-S2R2.

² During Deep-sleep, when the ULP co-processor is powered on, peripherals such as GPIO and I2C are able to operate.

³ The “ULP sensor-monitored pattern” refers to the mode where the ULP coprocessor or the sensor works periodically. When touch sensors work with a duty cycle of 1%, the typical current consumption is 22 μ A.

4.5 Wi-Fi RF Characteristics

4.5.1 Wi-Fi RF Standards

Table 15: Wi-Fi RF Standards

Name	Description	
Center frequency range of operating channel ¹	2412 ~ 2484 MHz	
Wi-Fi wireless standard	IEEE 802.11b/g/n	
Data rate	20 MHz	802.11b: 1, 2, 5.5 and 11 Mbps 802.11g: 6, 9, 12, 18, 24, 36, 48, 54 Mbps 802.11n: MCS0-7, 72.2 Mbps (Max)
	40 MHz	802.11n: MCS0-7, 150 Mbps (Max)
Antenna type	PCB antenna, external antenna connector	

[Not Recommended For New Designs \(NRND\)](#)

- ¹ Device should operate in the center frequency range allocated by regional regulatory authorities. The target center frequency range is configurable by software.
- ² For the modules that use external antenna connectors, the output impedance is 50 Ω . For other modules without external antenna connectors, the output impedance is irrelevant.

4.5.2 Transmitter Characteristics

Target TX power is configurable based on device or certification requirements. The default characteristics are provided in Table 16.

Table 16: TX Power with Spectral Mask and EVM Meeting 802.11 Standards

Rate	Min (dBm)	Typ (dBm)	Max (dBm)
802.11b, 1 Mbps, DSSS	—	19.5	—
802.11b, 11 Mbps, CCK	—	19.5	—
802.11g, 6 Mbps, OFDM	—	17.5	—
802.11g, 54 Mbps, OFDM	—	17.5	—
802.11n, HT20, MCS0	—	17.5	—
802.11n, HT20, MCS7	—	16.5	—
802.11n, HT40, MCS0	—	17.5	—
802.11n, HT40, MCS7	—	16.5	—

Table 17: TX EVM Test¹

Rate	Min (dB)	Typ (dB)	Limit (dB)
802.11b, 1 Mbps, DSSS	—	-25.0	-10.0
802.11b, 11 Mbps, CCK	—	-25.0	-10.0
802.11g, 6 Mbps, OFDM	—	-25.0	-5.0
802.11g, 54 Mbps, OFDM	—	-28.0	-25.0
802.11n, HT20, MCS0	—	-27.0	-5.0
802.11n, HT20, MCS7	—	-30.5	-27.0
802.11n, HT40, MCS0	—	-27.0	-5.0
802.11n, HT40, MCS7	—	-30.0	-27.0

¹ EVM is measured at the corresponding typical TX power provided in Table 16 *TX Power with Spectral Mask and EVM Meeting 802.11 Standards* above.

4.5.3 Receiver Characteristics

Table 18: RX Sensitivity

Rate	Min (dBm)	Typ (dBm)	Max (dBm)
802.11b, 1 Mbps, DSSS	—	-97.0	—
802.11b, 2 Mbps, DSSS	—	-94.5	—
802.11b, 5.5 Mbps, CCK	—	-92.0	—
802.11b, 11 Mbps, CCK	—	-88.0	—
802.11g, 6 Mbps, OFDM	—	-92.5	—
802.11g, 9 Mbps, OFDM	—	-91.0	—
802.11g, 12 Mbps, OFDM	—	-89.5	—
802.11g, 18 Mbps, OFDM	—	-87.5	—
802.11g, 24 Mbps, OFDM	—	-84.5	—
802.11g, 36 Mbps, OFDM	—	-80.5	—
802.11g, 48 Mbps, OFDM	—	-76.5	—
802.11g, 54 Mbps, OFDM	—	-75.0	—
802.11n, HT20, MCS0	—	-92.0	—
802.11n, HT20, MCS1	—	-89.0	—
802.11n, HT20, MCS2	—	-86.5	—
802.11n, HT20, MCS3	—	-83.5	—
802.11n, HT20, MCS4	—	-79.5	—
802.11n, HT20, MCS5	—	-75.5	—
802.11n, HT20, MCS6	—	-74.0	—
802.11n, HT20, MCS7	—	-72.5	—
802.11n, HT40, MCS0	—	-89.0	—
802.11n, HT40, MCS1	—	-86.5	—
802.11n, HT40, MCS2	—	-84.0	—
802.11n, HT40, MCS3	—	-80.0	—
802.11n, HT40, MCS4	—	-76.5	—
802.11n, HT40, MCS5	—	-72.5	—
802.11n, HT40, MCS6	—	-71.0	—
802.11n, HT40, MCS7	—	-69.5	—

Table 19: Maximum RX Level

Rate	Min (dBm)	Typ (dBm)	Max (dBm)
802.11b, 1 Mbps, DSSS	—	5	—
802.11b, 11 Mbps, CCK	—	5	—
802.11g, 6 Mbps, OFDM	—	5	—
802.11g, 54 Mbps, OFDM	—	0	—
802.11n, HT20, MCS0	—	5	—
802.11n, HT20, MCS7	—	0	—
802.11n, HT40, MCS0	—	5	—

Cont'd on next page

[Not Recommended For New Designs \(NRND\)](#)

Table 19 – cont'd from previous page

Rate	Min (dBm)	Typ (dBm)	Max (dBm)
802.11n, HT40, MCS7	–	0	–

Table 20: Adjacent Channel Rejection

Rate	Min (dB)	Typ (dB)	Max (dB)
802.11b, 1 Mbps, DSSS	–	35	–
802.11b, 11 Mbps, CCK	–	35	–
802.11g, 6 Mbps, OFDM	–	31	–
802.11g, 54 Mbps, OFDM	–	14	–
802.11n, HT20, MCS0	–	31	–
802.11n, HT20, MCS7	–	13	–
802.11n, HT40, MCS0	–	19	–
802.11n, HT40, MCS7	–	8	–

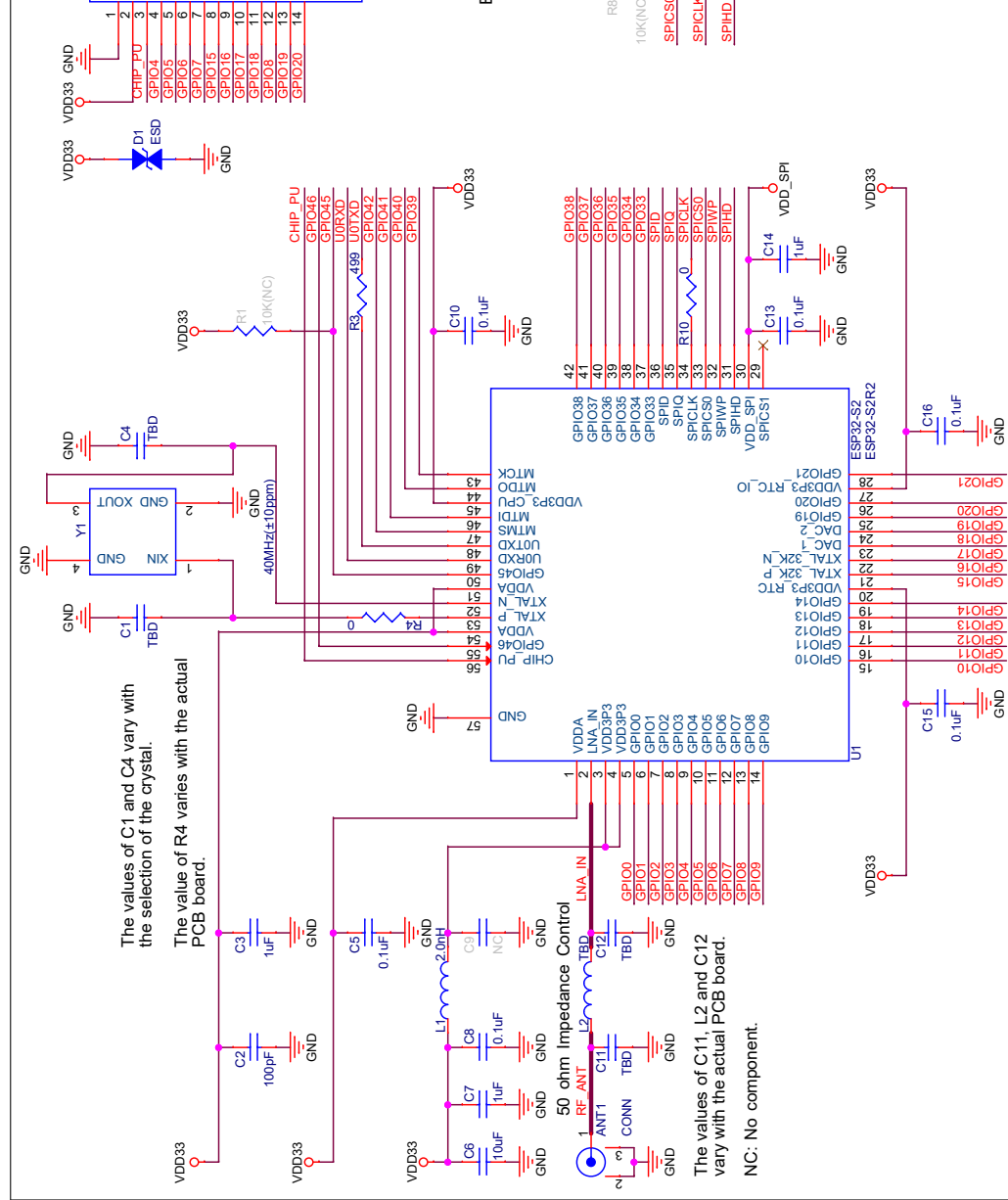

Figure 6: ESP32-S2-SOLO-U Schematics

6 Peripheral Schematics

This is the typical application circuit of the module connected with peripheral components (for example, power supply, antenna, reset button, JTAG interface, and UART interface).

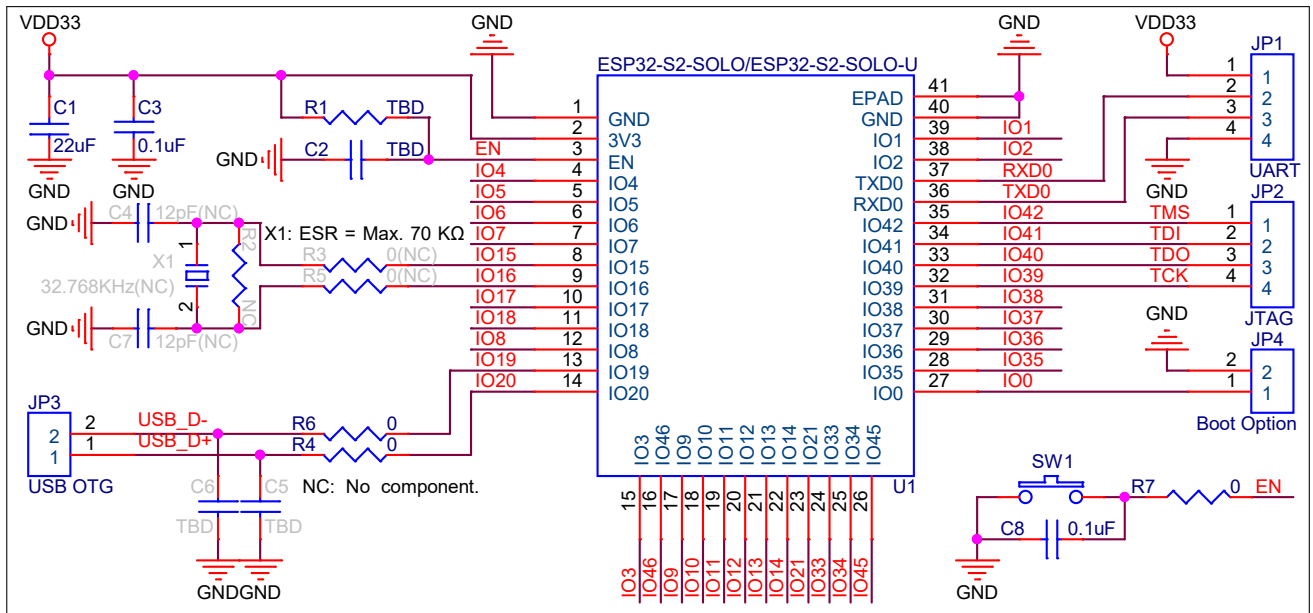

Figure 7: Peripheral Schematics

- Soldering the EPAD to the ground of the base board is not a must, however, it can optimize thermal performance. If you choose to solder it, please apply the correct amount of soldering paste. Too much soldering paste may increase the gap between the module and the baseboard. As a result, the adhesion between other pins and the baseboard may be poor.
- To ensure that the power supply to the ESP32-S2 chip is stable during power-up, it is advised to add an RC delay circuit at the EN pin. The recommended setting for the RC delay circuit is usually $R = 10\text{ k}\Omega$ and $C = 1\text{ }\mu\text{F}$. However, specific parameters should be adjusted based on the power-up timing of the module and the power-up and reset sequence timing of the chip. For ESP32-S2's power-up and reset sequence timing diagram, please refer to [ESP32-S2 Series Datasheet](#) > Section *Power Scheme*.

7 Physical Dimensions and PCB Land Pattern

7.1 Physical Dimensions

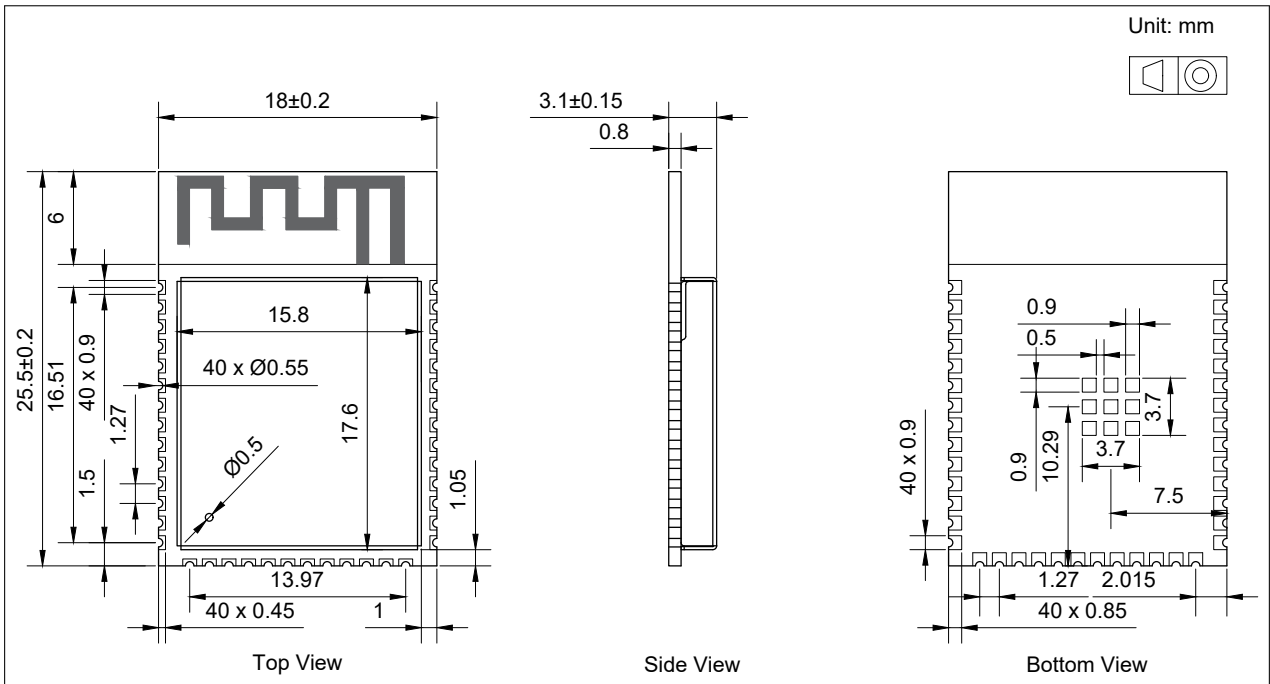

Figure 8: ESP32-S2-SOLO Physical Dimensions

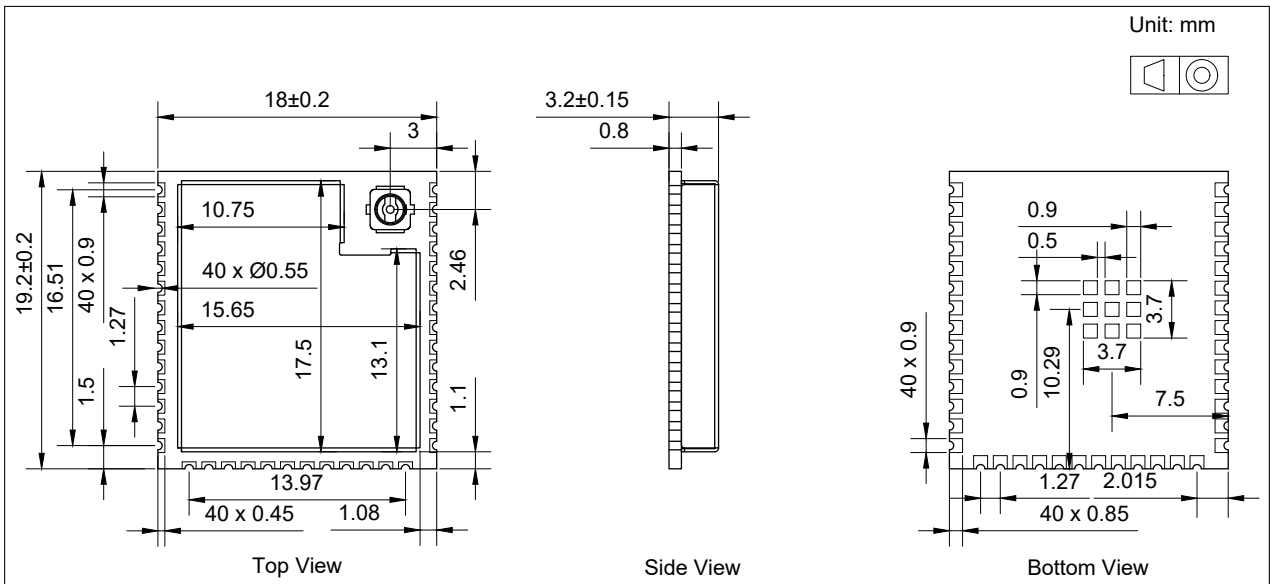

Figure 9: ESP32-S2-SOLO-U Physical Dimensions

Note:

For information about tape, reel, and product marking, please refer to [Espressif Module Packaging Information](#).

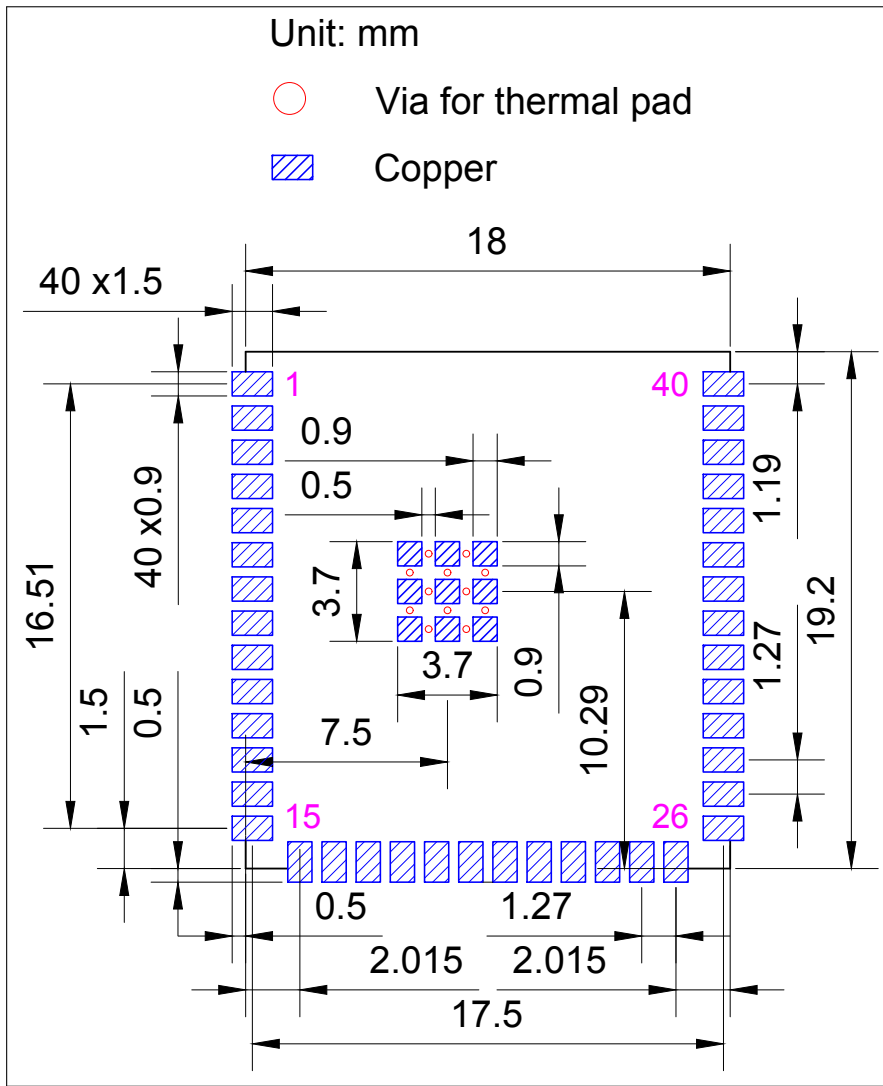

Figure 11: ESP32-S2-SOLO-U Recommended PCB Land Pattern

7.3 Dimensions of External Antenna Connector

ESP32-S2-SOLO-U uses the first generation external antenna connector as shown in Figure 12 *Dimensions of External Antenna Connector*. This connector is compatible with the following connectors:

- U.FL Series connector from Hirose
- MHF I connector from I-PEX
- AMC connector from Amphenol

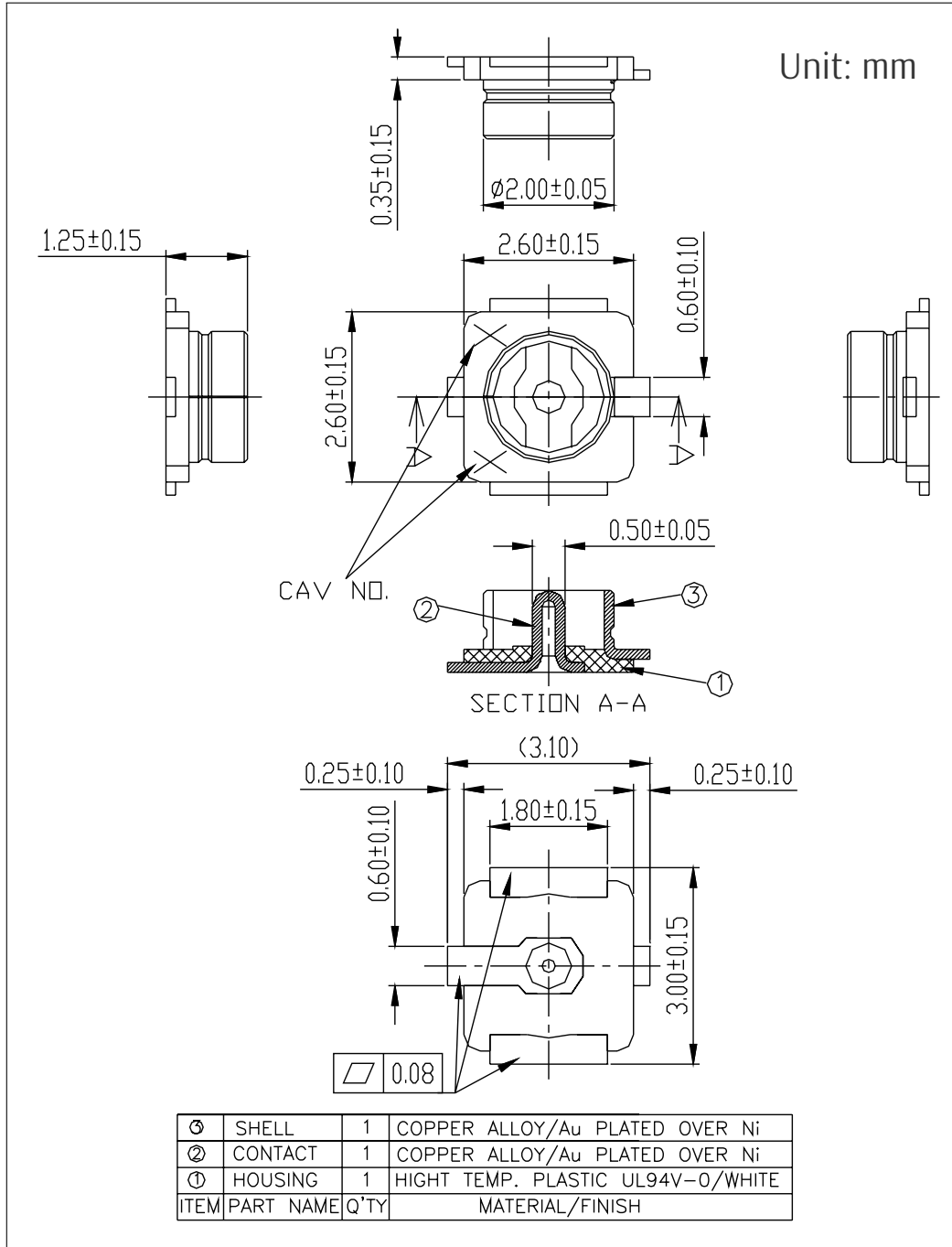

Figure 12: Dimensions of External Antenna Connector

8 Product Handling

8.1 Storage Conditions

The products sealed in moisture barrier bags (MBB) should be stored in a non-condensing atmospheric environment of $< 40\text{ }^{\circ}\text{C}$ and 90%RH. The module is rated at the moisture sensitivity level (MSL) of 3.

After unpacking, the module must be soldered within 168 hours with the factory conditions $25\pm 5\text{ }^{\circ}\text{C}$ and 60%RH. If the above conditions are not met, the module needs to be baked.

8.2 Electrostatic Discharge (ESD)

- Human body model (HBM): $\pm 2000\text{ V}$
- Charged-device model (CDM): $\pm 500\text{ V}$

8.3 Soldering Profile

8.3.1 Reflow Profile

Solder the module in a single reflow.

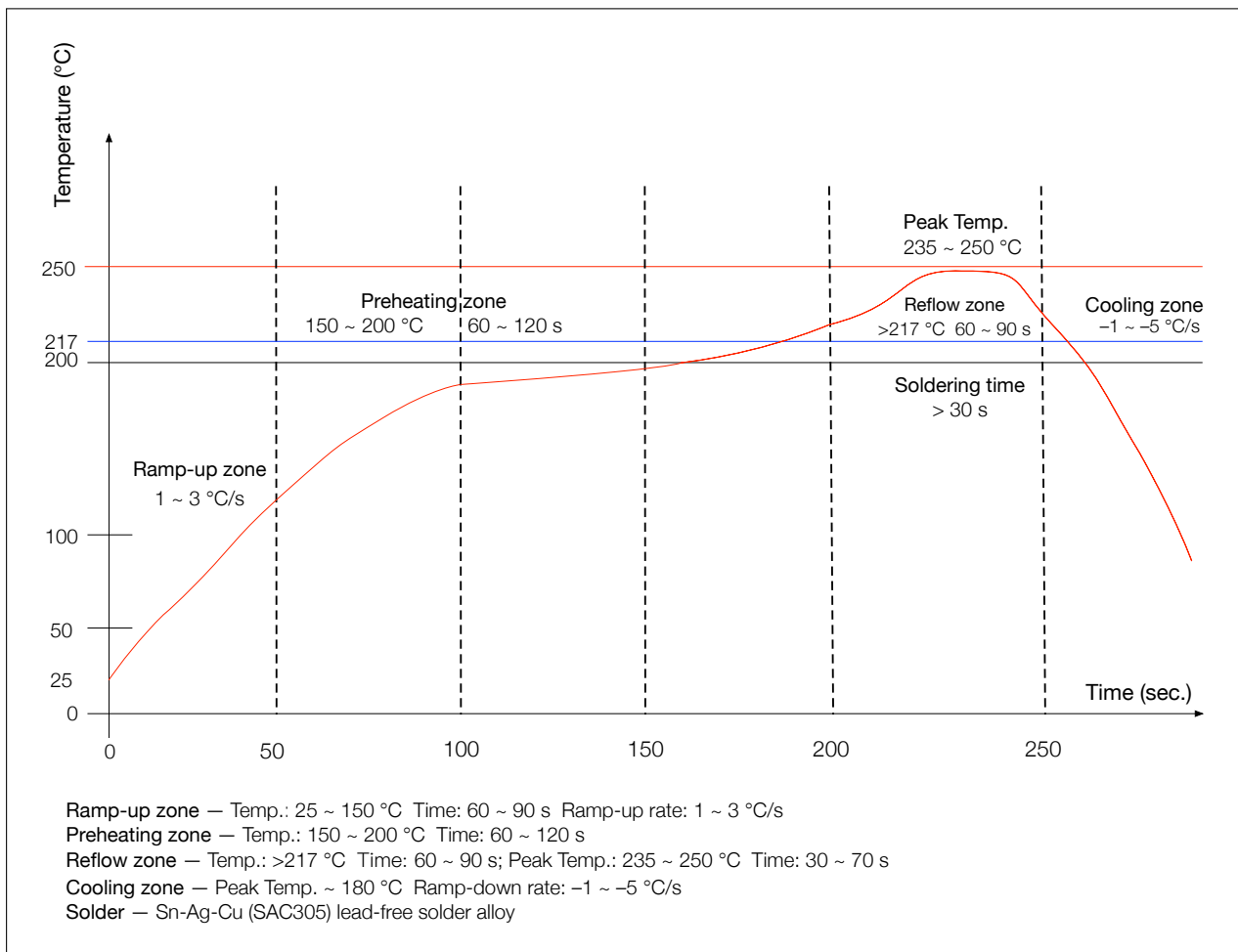

Figure 13: Reflow Profile

8.4 Ultrasonic Vibration

Avoid exposing Espressif modules to vibration from ultrasonic equipment, such as ultrasonic welders or ultrasonic cleaners. This vibration may induce resonance in the in-module crystal and lead to its malfunction or even failure. As a consequence, **the module may stop working or its performance may deteriorate.**

9 MAC Addresses and eFuse

The eFuse in ESP32-S2 series of chips has been burnt into 48-bit `mac_address`. The actual addresses the chip uses in station or AP modes correspond to `mac_address` in the following way:

- Station mode: `mac_address`
- AP mode: `mac_address + 1`

There are seven blocks in eFuse for users to use. Each block is 256 bits in size and has independent write/read disable controller. Six of them can be used to store encrypted key or user data, and the remaining one is only used to store user data.

Related Documentation and Resources

Related Documentation

- [ESP32-S2 Series Datasheet](#) – Specifications of the ESP32-S2 hardware.
- [ESP32-S2 Technical Reference Manual](#) – Detailed information on how to use the ESP32-S2 memory and peripherals.
- [ESP32-S2 Hardware Design Guidelines](#) – Guidelines on how to integrate the ESP32-S2 into your hardware product.
- [ESP32-S2 Series SoC Errata](#) – Descriptions of known errors in ESP32-S2 series of SoCs.
- *Certificates*
<https://espressif.com/en/support/documents/certificates>
- *ESP32-S2 Product/Process Change Notifications (PCN)*
<https://espressif.com/en/support/documents/pcns?keys=ESP32-S2>
- *ESP32-S2 Advisories* – Information on security, bugs, compatibility, component reliability.
<https://espressif.com/en/support/documents/advisories?keys=ESP32-S2>
- *Documentation Updates and Update Notification Subscription*
<https://espressif.com/en/support/download/documents>

Developer Zone

- [ESP-IDF Programming Guide for ESP32-S2](#) – Extensive documentation for the ESP-IDF development framework.
- *ESP-IDF* and other development frameworks on GitHub.
<https://github.com/espressif>
- *ESP32 BBS Forum* – Engineer-to-Engineer (E2E) Community for Espressif products where you can post questions, share knowledge, explore ideas, and help solve problems with fellow engineers.
<https://esp32.com/>
- *The ESP Journal* – Best Practices, Articles, and Notes from Espressif folks.
<https://blog.espressif.com/>
- See the tabs *SDKs and Demos, Apps, Tools, AT Firmware*.
<https://espressif.com/en/support/download/sdks-demos>

Products

- *ESP32-S2 Series SoCs* – Browse through all ESP32-S2 SoCs.
<https://espressif.com/en/products/socs?id=ESP32-S2>
- *ESP32-S2 Series Modules* – Browse through all ESP32-S2-based modules.
<https://espressif.com/en/products/modules?id=ESP32-S2>
- *ESP32-S2 Series DevKits* – Browse through all ESP32-S2-based devkits.
<https://espressif.com/en/products/devkits?id=ESP32-S2>
- *ESP Product Selector* – Find an Espressif hardware product suitable for your needs by comparing or applying filters.
<https://products.espressif.com/#/product-selector?language=en>

Contact Us

- See the tabs *Sales Questions, Technical Enquiries, Circuit Schematic & PCB Design Review, Get Samples* (Online stores), *Become Our Supplier, Comments & Suggestions*.
<https://espressif.com/en/contact-us/sales-questions>

Revision History

Date	Version	Release notes
2024-04-23	v1.7	<ul style="list-style-type: none"> Marked ESP32-S2-SOLO-H4 and ESP32-S2-SOLO-U-H4 as end of life, and other variants as NRND According to PCN20230601 and PCN20230702, upgraded the chip ESP32-S2 and ESP32-S2R2 from chip revision v0.0 to chip revision v1.0, and information in Section 4.4.1 Power Consumption in Active Mode, Section 4.5 Wi-Fi RF Characteristics, and Section 6 Peripheral Schematics is updated to that of chip revision v1.0 accordingly
2023-05-25	v1.6	<ul style="list-style-type: none"> Changed Table <i>Ordering Information</i> to Table ESP32-S2-SOLO (ANT) Series Comparison¹ and Table ESP32-S2-SOLO-U (CONN) Series Comparison Added links to some reference documents in Section 1 Module Overview Updated EPAD descriptions in Section 6 Peripheral Schematics Added descriptions in Section 7.2 Recommended PCB Land Pattern Other formatting updates
2022-09-23	v1.5	<ul style="list-style-type: none"> Added Section 8.4 Ultrasonic Vibration Removed NRND watermark
2022-03-01	v1.4	<ul style="list-style-type: none"> Added module pictures on the title page Added NRND watermark Updated Section "Learning Resources" and renamed to "Related Documentation and Resources" Added a note with a link and QR code to the latest version of the document Updated Table 13 Current Consumption in Modem-sleep Mode and Table 14 Current Consumption in Low-Power Modes

Cont'd on next page

Cont'd from previous page

Date	Version	Release notes
2021-06-21	v1.3	<ul style="list-style-type: none"> ● Added module variants embedded with the ESP32-S2R2 chip ● Added module description to the title page ● Updated Chapter 1 <i>Module Overview</i> ● Updated <i>Pin Layout (Top View)</i>, in which IO3, IO46 and IO45 are newly added ● Updated Figure 10 <i>ESP32-S2-SOLO Recommended PCB Land Pattern</i> ● Added description in Section 7.3 <i>Dimensions of External Antenna Connector</i> ● Replaced "chip family" with "chip series" following Espressif's taxonomy
2020-12-17	v1.2	<ul style="list-style-type: none"> ● Added TWAI to Chapter 1 <i>Module Overview</i> ● Updated Table 12 <i>Current Consumption for Wi-Fi (2.4 GHz) in Active Mode</i> ● Updated the capacitance value of RC delay circuit to 1 μF in Chapter 6 <i>Peripheral Schematics</i> ● Updated note in Section 8.3.1 <i>Reflow Profile</i>
2020-07-31	v1.1	Updated notes in Table Ordering Information
2020-07-22	v1.0	Official release
2020-05-19	v0.1	Preliminary release



www.espressif.com

Disclaimer and Copyright Notice

Information in this document, including URL references, is subject to change without notice.

ALL THIRD PARTY'S INFORMATION IN THIS DOCUMENT IS PROVIDED AS IS WITH NO WARRANTIES TO ITS AUTHENTICITY AND ACCURACY.

NO WARRANTY IS PROVIDED TO THIS DOCUMENT FOR ITS MERCHANTABILITY, NON-INFRINGEMENT, FITNESS FOR ANY PARTICULAR PURPOSE, NOR DOES ANY WARRANTY OTHERWISE ARISING OUT OF ANY PROPOSAL, SPECIFICATION OR SAMPLE.

All liability, including liability for infringement of any proprietary rights, relating to use of information in this document is disclaimed. No licenses express or implied, by estoppel or otherwise, to any intellectual property rights are granted herein.

The Wi-Fi Alliance Member logo is a trademark of the Wi-Fi Alliance. The Bluetooth logo is a registered trademark of Bluetooth SIG.

All trade names, trademarks and registered trademarks mentioned in this document are property of their respective owners, and are hereby acknowledged.

Copyright © 2024 Espressif Systems (Shanghai) Co., Ltd. All rights reserved.

[Not Recommended For New Designs \(NRND\)](#)

Looking for pricing, stock, or lifecycle information?

Click below to explore more details on WIN SOURCE:

- ⊖ [View ESP32-S2-SOLO-N4R2 on WIN SOURCE](#)
- ⊖ [Espressif Information](#)

Optimize Your Supply Chain with WIN SOURCE Solutions

- ✓ Global Sourcing Solution
- ✓ Obsolete Management
- ✓ Cost Control Management
- ✓ Shortage Management
- ✓ Alternative Solution
- ✓ Excess Inventory Management