



**THE DATASHEET OF  
ZSC31014EAG1-T**



## Brief Description

The ZSC31014 is a CMOS integrated circuit for highly accurate amplification and analog-to-digital conversion of differential and half-bridge input signals. The ZSC31014 can compensate the measured signal for offset, 1<sup>st</sup> and 2<sup>nd</sup> order span, and 1<sup>st</sup> and 2<sup>nd</sup> order temperature (Tco and Tcg). It is well suited for sensor-specific correction of bridge sensors. Digital compensation of signal offset, sensitivity, temperature drift, and non-linearity is accomplished via an internal digital signal processor running a correction algorithm with calibration coefficients stored in a non-volatile EEPROM.

The ZSC31014 is adjustable to nearly all piezo-resistive bridge sensors. Measured and corrected bridge values are provided at digital output pins, which can be configured as I<sup>2</sup>C<sup>™</sup>\* or SPI. The digital I<sup>2</sup>C<sup>™</sup> interface can be used for a simple PC-controlled calibration procedure to program calibration coefficients into an on-chip EEPROM. The calibrated ZSC31014 and a specific sensor are mated digitally: fast, precise, and without the cost overhead associated with trimming by external devices or laser trimming.

The ZSC31014's integrated diagnostics functions are well suited for safety-critical applications.

## Features

- High accuracy ( $\pm 0.1\%$  FSO @ -25 to +85°C;  $\pm 0.25\%$  FSO @ -40 to +125°C)
- 2<sup>nd</sup> order charge-balancing analog-to-digital converter provides low noise, 14-bit data at sample rates exceeding 2kHz
- Fast power-up to data output response: 3ms at 4MHz
- Digital compensation of sensor offset, sensitivity, temperature drift, and non-linearity
- Eight programmable analog gain settings combine with a digital gain term; accommodates bridges with spans <1mV/V and high offset
- Internal temperature compensation for sensor correction and for corrected temperature output
- 48-bit customer ID field for module traceability

\* I<sup>2</sup>C<sup>™</sup> is a trademark of NXP.

## Benefits

- Simple PC-controlled configuration and single-pass digital calibration via I<sup>2</sup>C<sup>™</sup> interface – quick and precise; SPI option for measurement mode
- Eliminates need for external trimming components
- On-chip diagnostic features add safety to the application (e.g., EEPROM signature, bridge connection checks, bridge short detection).
- Low-power Sleep Mode lengthens battery life
- Enables multiple sensor networks

## Available Support

- Evaluation Kit
- Application Notes
- Mass Calibration Solution

## Physical Characteristics

- Wide supply voltage capability: 2.7V to 5.5V
- Current consumption as low as 70µA depending on programmed sample rate
- Low-power Sleep Mode (<2µA @ 25°C)
- Operation temperature: -40°C to +125°C
- Small SOP8 package

### ZSC31014 Application: I<sup>2</sup>C<sup>™</sup> Interface, Low-Power Bsink Option, Internal Temperature Correction

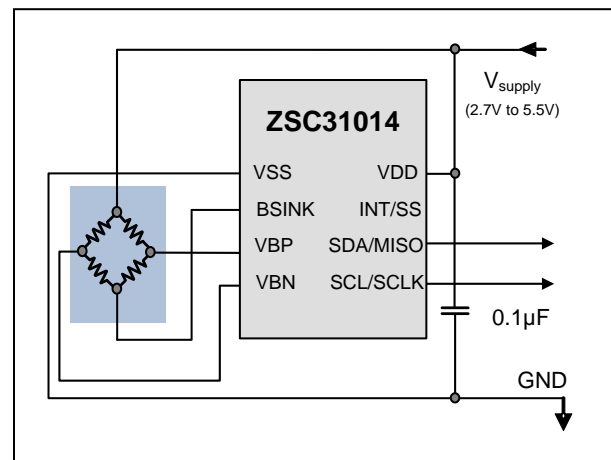

**ZSC31014 Block Diagram**

**Applications:**

**Industrial:** building automation, data loggers, pressure meters, leak detection monitoring

**Medical:** infusion pumps, blood pressure meters, air mattresses, apnea monitors

**White Goods / Appliances:** fluid level, refrigerant

**Consumer:** body monitors, portable monitors, desktop weather stations, bathroom scales, toys/games

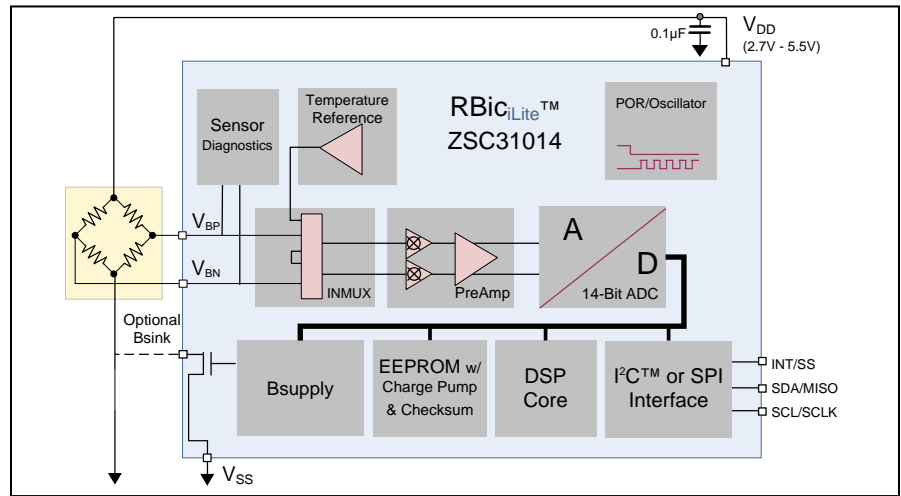

**Application: Half-Bridge Voltage Measurement**

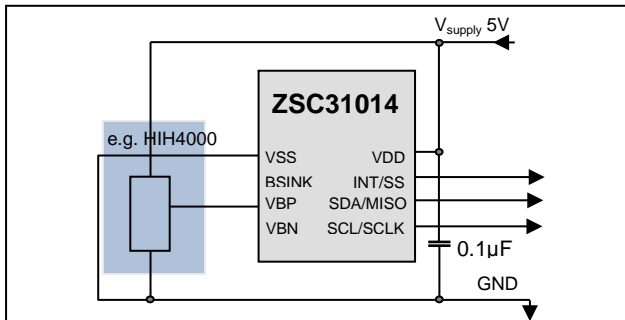

**Application: Generic Differential A2D Converter**

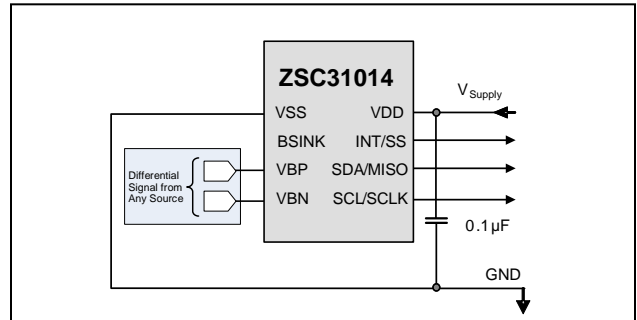

**Ordering Examples** (Refer to section 10 in the data sheet for additional options.)

Sales Code	Description	Package
ZSC31014EAB	ZSC31014 Die — Temperature range: -40°C to +125°C	Unsawn on Wafer
ZSC31014EAC	ZSC31014 Die — Temperature range: -40°C to +125°C	Sawn on Wafer Frame
ZSC31014EAG1	ZSC31014 SOP8 (150 mil) — Temperature range: -40° to +125°C	Tube: add "-T" to sales code / Reel: add "-R"
ZSC31014KIT	ZSC31014 SSC Evaluation Kit: Communication Board, SSC Board, Sensor Replacement Board, USB Cable, 5 IC Samples (software can be downloaded on <a href="http://www.IDT.com/ZSC31014">www.IDT.com/ZSC31014</a> )	

## Contents

List of Figures .....	4
List of Tables .....	5
1 IC Characteristics .....	6
1.1. Absolute Maximum Ratings .....	6
1.2. Recommended Operating Conditions .....	6
1.3. Electrical Parameters .....	7
1.4. Current Consumption .....	9
1.4.1. Update Mode Current Consumption .....	9
1.4.2. Sleep Mode Current Consumption.....	10
1.5. Analog Input versus Output Resolution .....	10
2 Circuit Description .....	13
2.1. Signal Flow and Block Diagram.....	13
2.2. Analog Front End.....	14
2.2.1. Preamplifier (PreAmp).....	14
2.2.2. Analog-to-Digital Converter.....	15
2.2.3. Temperature Measurement .....	18
2.2.4. Bridge Supply (Bsink).....	18
2.2.5. Analog Front-End Configuration .....	19
2.3. Digital Signal Processor .....	19
2.3.1. Digital Core .....	19
2.3.2. Normal Operation Mode.....	20
2.3.3. EEPROM.....	20
2.3.4. Digital Interface – I <sup>2</sup> C™ .....	20
2.3.5. Digital Interface – SPI .....	22
2.3.6. Clock Generator / Power-On Reset (CLKPOR).....	23
2.4. Diagnostic Features.....	23
2.4.1. EEPROM Integrity.....	25
2.4.2. Sensor Connection Check .....	25
2.4.3. Sensor Short Check .....	25
3 Functional Description.....	26
3.1. General Working Mode.....	26
3.1.1. Update Mode.....	28
3.1.2. Sleep Mode .....	30
3.2. ZSC31014 Read Operations with I <sup>2</sup> C™ .....	33
3.2.1. I <sup>2</sup> C™ Read_MR (Measurement Request) .....	34
3.2.2. I <sup>2</sup> C™ Read_DF (Data Fetch) .....	34
3.3. SPI Read Operations.....	34
3.3.1. SPI Read_MR (Measurement Request) .....	34

3.3.2.	SPI Read_DF (Data Fetch).....	35
3.4.	I <sup>2</sup> C™ Write Operations.....	36
3.4.1.	I <sup>2</sup> C™ Write_MR (Measurement Request).....	36
3.4.2.	Command Mode I <sup>2</sup> C™ Write Operations.....	37
3.5.	Command/Data Pair Encoding in Command Mode.....	37
3.6.	EEPROM Bits.....	38
3.7.	Calibration Sequence.....	44
3.8.	Calibration Math.....	45
3.8.1.	Bridge Signal Compensation.....	46
3.8.2.	Temperature Signal Compensation.....	47
3.8.3.	Limits Imposed on Coefficient Ranges.....	47
3.8.4.	Interpretation of Binary Numbers for Correction Coefficients.....	48
4	Application Circuit Examples.....	50
4.1.	I <sup>2</sup> C™ Interface – Bridge using Low Power Bsink Option.....	50
4.2.	Generic Differential A2D Converter.....	51
4.3.	Half-Bridge Measurement.....	52
5	ESD/Latch-Up-Protection.....	53
6	Pin Configuration and Package.....	53
7	Test.....	54
8	Reliability.....	55
9	Customization.....	55
10	Ordering Codes.....	55
11	Related Documents.....	56
12	Definitions of Acronyms.....	56
13	Document Revision History.....	57

## List of Figures

Figure 1.1	Update Mode Current Consumption with Minimum Update Rate.....	9
Figure 1.2	Update Mode Current Consumption with Maximum Update Rate.....	9
Figure 1.3	Sleep Mode Current Consumption.....	10
Figure 2.1	ZSC31014 Block Diagram.....	13
Figure 2.2	Functional Diagram of the ADC.....	17
Figure 2.3	Format for AFE Configuration Registers B_Config and T_Config.....	19
Figure 2.4	I <sup>2</sup> C™ Timing Diagram.....	21
Figure 2.5	SPI Bus Data Output Timing.....	23
Figure 3.1	General Working Mode.....	27
Figure 3.2	Power-Up Sequence and Timing for Update Mode with EEPROM Locked.....	28
Figure 3.3	Measurement Sequence in Update Mode.....	30
Figure 3.4	Power-on Sequence in Sleep Mode for I <sup>2</sup> C™ or SPI Read_MR (Typical Timing Values).....	32
Figure 3.5	Sequence during Sleep Mode Using an I <sup>2</sup> C™ Write_MR to Wake Up (Typical Timing Values)**.....	32

Figure 3.6	I <sup>2</sup> C™ Measurement Packet Reads .....	33
Figure 3.7	SPI Read_MR .....	34
Figure 3.8	SPI Output Packet with Falling Edge SPI_Polarity .....	35
Figure 3.9	I <sup>2</sup> C™ Measurement Packet Writes .....	36
Figure 4.1	Example 1 Circuit Diagram: Bsink Option and Internal Temperature Correction and I <sup>2</sup> C™ Output	50
Figure 4.2	Example 2 Circuit Diagram: Generic Differential A2D Converter .....	51
Figure 4.3	Half-Bridge Voltage Measurement with Internal Temperature Correction.....	52
Figure 6.1	ZSC31014 Pin-Out Diagram.....	54

## List of Tables

Table 1.1	ZSC31014 Maximum Ratings.....	6
Table 1.2	ZSC31014 Recommended Operating Conditions .....	6
Table 1.3	ZSC31014 Electrical Parameters .....	7
Table 1.4	Minimum Guaranteed Resolution for the Analog Gain Settings.....	11
Table 2.1	Preamplifier Gain Control Signals .....	14
Table 2.2	Gain Polarity Control Signal.....	14
Table 2.3	Disable Nulling Control Signal .....	15
Table 2.4	A2D_Offset Signals .....	16
Table 2.5	Parameters of the Internal Temperature Sensor Bridge .....	18
Table 2.6	Supported I <sup>2</sup> C™ Bit Rates .....	20
Table 2.7	I <sup>2</sup> C™ Parameters.....	21
Table 2.8	SPI Parameters.....	22
Table 2.9	2 MSB of Data Packet Encoding .....	24
Table 3.1	Command Types .....	26
Table 3.2	Update Rate Settings (Normal Integration Mode: 9 Coarse + 5 Fine) .....	29
Table 3.3	Update Rate Settings (Long Integration Mode: 10 Coarse + 5 Fine) .....	29
Table 3.4	Sleep Mode Response Times (Normal Integration Mode: 9 Coarse + 5 Fine) .....	31
Table 3.5	Sleep Mode Response Times (Long Integration Mode: 10 Coarse + 5 Fine).....	31
Table 3.6	Command List and Encodings.....	37
Table 3.7	EEPROM Word/Bit Assignments.....	38
Table 3.8	Restrictions on Coefficient Ranges.....	47
Table 3.9	Gain_B Weightings .....	48
Table 3.10	Offset_B Weightings .....	48
Table 4.1	Register Settings—Example 1 .....	50
Table 4.2	Register Settings—Example 2.....	51
Table 4.3	Register Settings—Example 3.....	52
Table 6.1	Storage and Soldering Conditions for the SOP-8 Package.....	53
Table 6.2	ZSC31014 Pin Assignments.....	54

# 1 IC Characteristics

## 1.1. Absolute Maximum Ratings

**Table 1.1 ZSC31014 Maximum Ratings**

PARAMETER	SYMBOL	MIN	TYP	MAX	UNITS
Analog Supply Voltage	$V_{DD}$	-0.3		6.0	V
Voltages at Digital and Analog I/O – In Pin	$V_{INA}$	-0.3		$V_{DD}+0.3$	V
Voltages at Digital and Analog I/O – Out Pin	$V_{OUTA}$	-0.3		$V_{DD}+0.3$	V
Storage Temperature Range ( $\geq 10$ hours)	$T_{STOR}$	-50		150	$^{\circ}C$
Storage Temperature Range ( $< 10$ hours)	$T_{STOR<10h}$	-50		170	$^{\circ}C$

Note: Also see Table 6.1 regarding soldering temperature and storage conditions for the SOP-8 package.

## 1.2. Recommended Operating Conditions

**Table 1.2 ZSC31014 Recommended Operating Conditions**

PARAMETER	SYMBOL	MIN	TYP	MAX	UNITS
Analog Supply Voltage to Gnd	$V_{DD}$	2.7		5.5	V
Ambient Temperature Range <sup>1)</sup>	$T_{AMB}$	-40		125	$^{\circ}C$
CM Voltage Range <sup>2)</sup>	$V_{IN}$	1		$V_{DD}-1.2$	V
External Capacitance between $V_{DD}$ and Gnd	$C_{VDD}$	100	220	470	nF
Pull-up on SDA and SCL	$R_{PU}$	1			$k\Omega$
Bridge Resistance	$R_{BR}$	0.2		100	$k\Omega$

1) If buying die, designers should use caution not to exceed maximum junction temperature by proper package selection.

2) Both BP and BN input voltage must be within the specified range. In Half-Bridge Mode, this requirement applies only to the BP input (gain 1.5 and 3). In this mode, BN is connected internally to  $V_{DD}/2$ .

### 1.3. Electrical Parameters

Note: See important notes at the end of the table.

**Table 1.3 ZSC31014 Electrical Parameters**

PARAMETER	SYMBOL	CONDITIONS	MIN	TYP	MAX	UNITS
<b>SUPPLY</b>						
Update Mode Supply Current (See section 1.4.1)	I <sub>DD</sub>	At minimum update rate (1MHz clock)	70	120		μA
		At maximum update rate (4MHz clock). See section 3.1.1 for more details. Minimum current is achieved at slow update rates.		2000	2500	
Sleep Mode Supply Current (See section 1.4.2)	I <sub>sndby</sub>	-40°C to +85°C		0.5	5	μA
		-40°C to +125°C		0.5	32	μA
Power-On-Reset Level	POR		1.8		2.5	V
<b>ANALOG FRONT END (AFE)</b>						
Leakage Current Pins VBP, VBN	I <sub>IN_LEAK</sub>	Sensor connection and short checks must be disabled.			±20	nA
<b>EEPROM</b>						
Number of Erase/Write Cycles	n <sub>WRI_EEP</sub>	At 85°C			100k	Cycles
Data Retention	t <sub>WRI_EEP</sub>	At 100°C			10	Years
<b>ANALOG-TO-DIGITAL CONVERTER (ADC)</b>						
Resolution	r <sub>ADC</sub>			14		Bits
Temperature Resolution					11	Bits
Integral Nonlinearity (INL) <sup>1)</sup>	INL <sub>ADC</sub>	Based on ideal slope	-4		+4	LSB
Differential Nonlinearity <sup>2)</sup> (DNL)	DNL <sub>ADC</sub>		-1		+1	LSB
<b>I<sup>2</sup>C™ INTERFACE &amp; SPI INTERFACE</b>						
Input Low Level	V <sub>IN_low</sub>	SDA/MISO and SCL/SCLK	0		0.2	V <sub>DD</sub>
Input High Level	V <sub>IN_high</sub>	SDA/MISO and SCL/SCLK	0.8		1	V <sub>DD</sub>
Input leakage to V <sub>SS</sub>	I <sub>il</sub>	SDA/MISO, SCL/SCLK, and INT/SS with output disabled	-1.0		+1.0	μa
Input leakage to V <sub>DD</sub>	I <sub>ih</sub>	SDA/MISO and INT/SS with output disabled	-1.0		+1.0	μa
	I <sub>ih_PU</sub>	SCL/SCLK with weak pull-up		-1.2	-5	μa
Output Sourcing Current	I <sub>OH_SDA/MISO</sub>	SDA/MISO @V <sub>OH</sub> = V <sub>DD</sub> -0.2v	-1.9	-3.1	-4.8	mA
	I <sub>OH_INT/SS</sub>	INT/SS @V <sub>OH</sub> = V <sub>DD</sub> -0.2v	-0.63	-1.2	-1.9	mA

PARAMETER	SYMBOL	CONDITIONS	MIN	TYP	MAX	UNITS
Output Sink Current	I <sub>OL_SDA/MISO</sub>	SDA/MISO @V <sub>OI</sub> = 0.2v	2.3	3.9	6.2	mA
	I <sub>OL_INT/SS</sub>	INT/SS @V <sub>OI</sub> = 0.2v	0.85	1.7	3.0	mA
Load Capacitance at SDA	C <sub>SDA</sub>	@ 400kHz			200	pF
Pull-up Resistor	R <sub>I2C_PU</sub>		500			Ω
Input Capacitance (each pin)	C <sub>I2C_IN</sub>				10	pF
<b>TOTAL SYSTEM</b>						
Frequency Variation	f <sub>var</sub>	All timing in the specification is subject to this variation.			±15	%
Start-Up-Time <sup>3), 4), 5)</sup> (Power-up to data ready)	t <sub>STA</sub>	@ 4MHz(EEPROM locked)		2.8	3.2	ms
		@ 4MHz(EEPROM unlocked)		7.3	8.4	
Response Time <sup>3), 4), 5)</sup> (Time to data ready)	f <sub>meas</sub>	@ 1MHz(EEPROM locked)		6.0	6.9	ms
		@ 1MHz(EEPROM unlocked)		10.4	12	
Overall Linearity Error <sup>6), 7), 8)</sup>	E <sub>LIND</sub>	Within 5% to 95% of full-scale differential input.			±0.05	%FSO
Overall Ratiometricity Error <sup>6), 9)</sup>	RE <sub>out</sub>	VDD ± 10%		±0.025	±0.1	%FSO
Overall Absolute Error <sup>6), 10)</sup>	AC <sub>out</sub>	-25°C to +85°C, VDD ± 10%			±0.1	%FSO
		-40°C to +125°C, VDD ± 10%			±0.25	%FSO
1) Measured at highest PreAmp_Gain setting and -1/2 to 1/2 A2D_Offset setting. 2) Parameter not tested during production test but guaranteed by design. 3) In Update Rate Mode at fastest update rate. 4) See section 3.1 for more details. 5) Parameter indirectly tested during production test. 6) Bridge input to digital output. 7) For applications where Vdd <3.5V using A2D offsets 15/16, 7/8, 1/8, or 1/16, a slight overall linearity improvement of 0.015% FSO can be achieved. 8) FSO = percent full-scale output. 9) For high preamp gain (≥96) in conjunction with high clock frequency and normal integration (4MHz, longInt=0), the ratiometricity error can be ≤0.3%. 10) For applications requiring high preamp gain (≥96) in conjunction with a high clock frequency (4 MHz), calibration using three temperature points is required in order to achieve the specified "Overall Absolute Error." If calibration is performed using only two temperature points, the specified maximum error values must be increased by a factor of 3. A calibration using only one temperature point is not recommended for applications with high preamp gain (≥96) in conjunction with a high clock frequency (4 MHz).						

## 1.4. Current Consumption

### 1.4.1. Update Mode Current Consumption

Figure 1.1 Update Mode Current Consumption with Minimum Update Rate

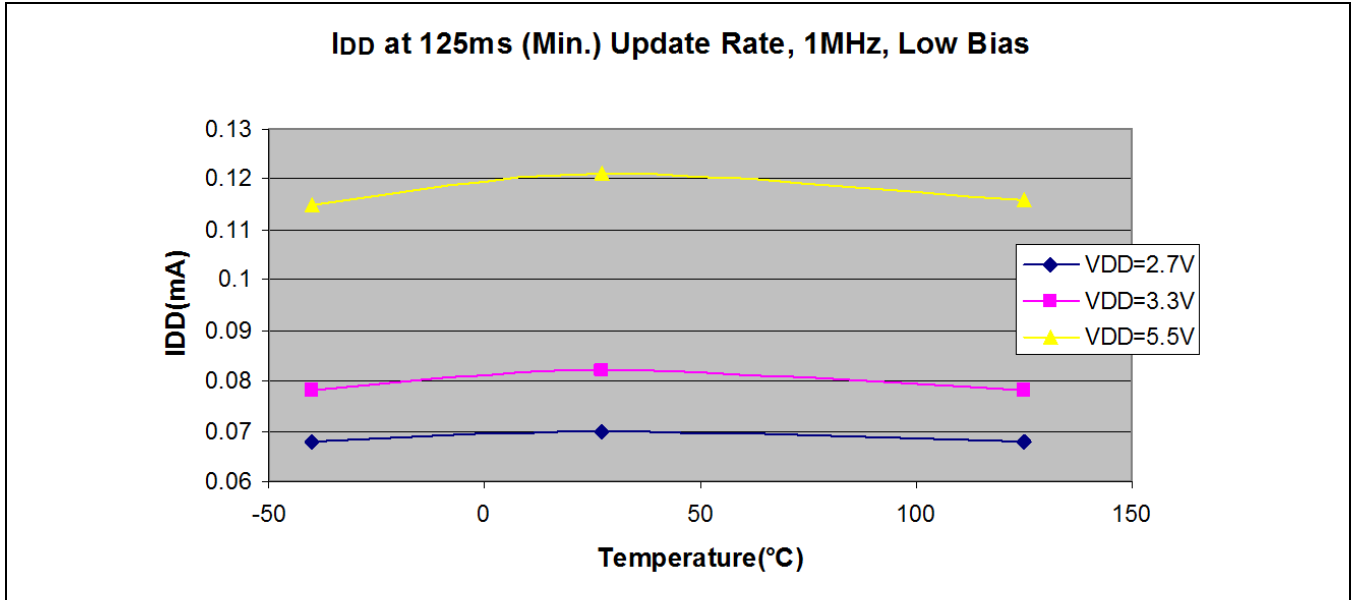
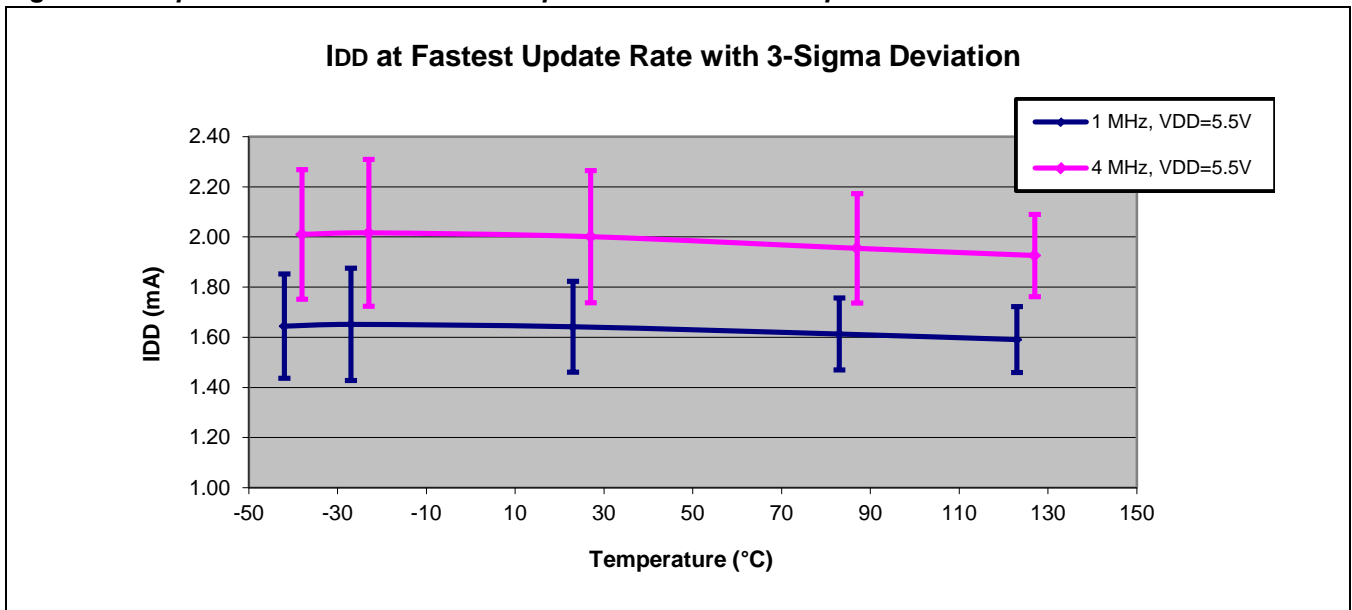
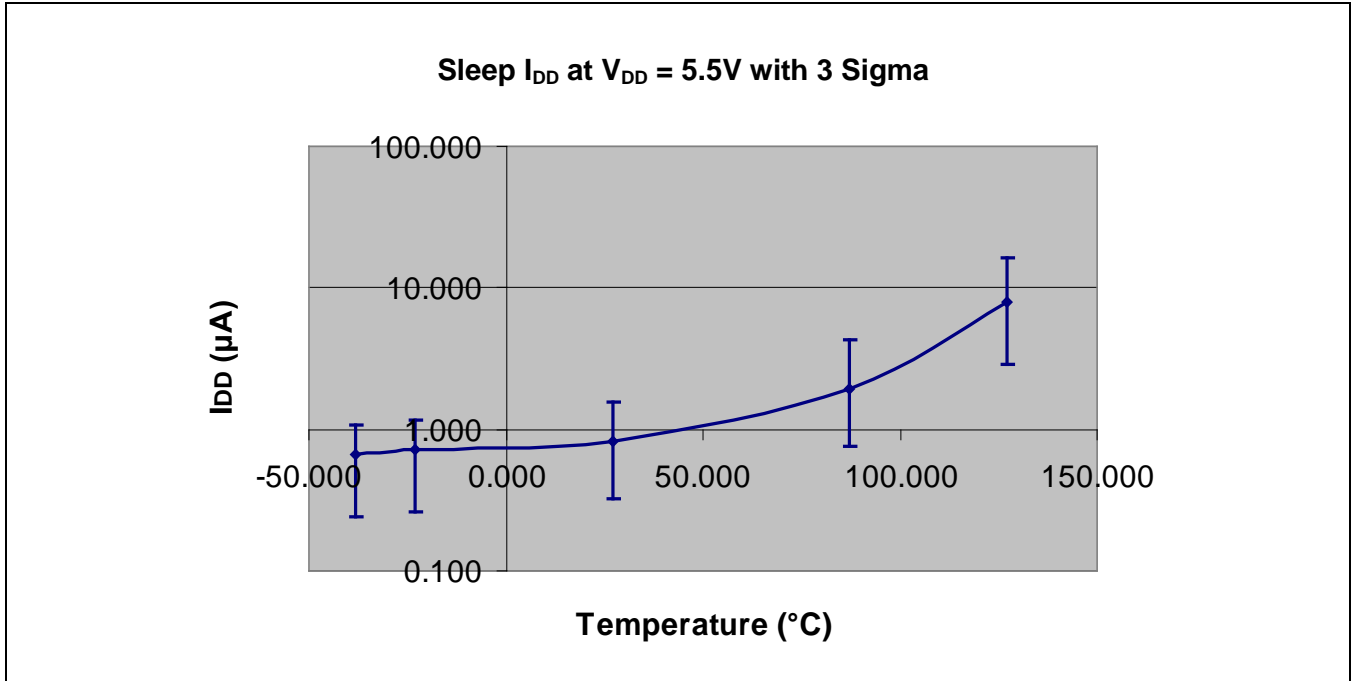

Figure 1.2 Update Mode Current Consumption with Maximum Update Rate



1.4.2. Sleep Mode Current Consumption

Figure 1.3 Sleep Mode Current Consumption



1.5. Analog Input versus Output Resolution

The ZSC31014 has a fully differential chopper-stabilized preamplifier with 8 programmable gain settings through a 14-bit analog-to-digital converter (ADC). The resolution of the output depends on the input span (bridge sensitivity) and the analog gain setting programmed. Analog gains available are 1.5, 3, 6, 12, 24, 48, 96, and 192.\*

Table 1.4 gives the guaranteed minimum resolution for a given bridge sensitivity range for the eight analog gain settings. At higher analog gain settings, there will be higher output resolution, but the ability of the ASIC to handle large offsets decreases. This is expected because the offset is also amplified by the analog gain and can therefore saturate the ADC input.

\* For previous silicon revision A, the available analog gain settings are 1, 3, 5, 15, 24, 40, 72, and 120. See *ZSC31014\_AFE\_Settings.xls* for table values for revision A.

**Table 1.4 Minimum Guaranteed Resolution for the Analog Gain Settings**

Analog Gain = 1.5				
Input Span (mV/V)			Allowed Offset (mV/V)	Min. Guaranteed Resolution (Bits)
Min	Typ	Max		
289	400	529	69	12.7
235	325	430	118	12.4
181	250	331	168	12.1
126	175	231	218	11.6
90	125	165	251	11.1
54	75	99	284	10.3
43	60	79	294	10.0

Analog Gain = 3				
Input Span (mV/V)			Allowed Offset (mV/V)	Min. Guaranteed Resolution (Bits)
Min	Typ	Max		
145	200	265	34	12.7
123	170	225	54	12.5
101	140	185	74	12.2
80	110	145	94	11.9
58	80	106	114	11.4
36	50	66	134	10.7
22	30	40	147	10.0

Analog Gain = 6				
Input Span (mV/V)			Allowed Offset (mV/V)	Min. Guaranteed Resolution (Bits)
Min	Typ	Max		
65	90	119	24	12.6
61	85	112	27	12.5
51	70	93	37	12.2
43	60	79	44	12.0
40	55	73	47	11.9
36	50	66	50	11.7
29	40	53	57	11.4

Analog Gain = 12				
Input Span (mV/V)			Allowed Offset (mV/V)	Min. Guaranteed Resolution (Bits)
Min	Typ	Max		
36	50	66	9	12.7
30	42	56	14	12.5
25	34	45	19	12.2
19	26	34	24	11.8
13	18	24	30	11.3
7	10	13	35	10.4
6	8	11	36	10.1

Analog Gain = 24				
Input Span (mV/V)			Allowed Offset (mV/V)	Min. Guaranteed Resolution (Bits)
Min	Typ	Max		
18.1	25.0	33.1	4.3	12.7
15.2	21.0	27.8	6.9	12.5
12.3	17.0	22.5	9.6	12.2
9.4	13.0	17.2	12.2	11.8
6.5	9.0	11.9	14.9	11.3
3.6	5.0	6.6	17.5	10.4
2.9	4.0	5.3	18.2	10.1

Analog Gain = 48				
Input Span (mV/V)			Allowed Offset (mV/V)	Min. Guaranteed Resolution (Bits)
Min	Typ	Max		
8.7	12.0	15.9	0.4	12.7
7.2	10.0	13.2	1.7	12.4
5.8	8.0	10.6	2.9	12.1
4.3	6.0	7.9	4.2	11.7
2.9	4.0	5.3	5.4	11.1
2.2	3.0	4.0	6.7	10.7
1.4	2.0	2.6	7.3	10.1

Analog Gain = 96				
Input Span (mV/V)			Allowed Offset (mV/V)	Min. Guaranteed Resolution (Bits)
Min	Typ	Max		
4.3	6.0	7.9	1.2	12.7
2.9	4.0	5.3	2.6	12.1
1.8	2.5	3.3	3.6	11.4
1.4	2.0	2.6	3.9	11.1
1.2	1.6	2.1	4.2	10.8
0.9	1.3	1.7	4.3	10.5
0.7	1.0	1.3	4.5	10.1

Analog Gain = 192				
Input Span (mV/V)			Allowed Offset (mV/V)	Min. Guaranteed Resolution (Bits)
Min	Typ	Max		
1.81	2.50	3.31	1.0	12.4
1.45	2.00	2.65	1.3	12.1
1.08	1.50	1.98	1.6	11.7
0.90	1.25	1.65	1.8	11.4
0.72	1.00	1.32	1.9	11.1
0.51	0.70	0.93	2.1	10.6
0.36	0.50	0.66	2.3	10.1

## 2 Circuit Description

### 2.1. Signal Flow and Block Diagram

The ZSC31014 uses a charge-balancing ADC that provides low noise 14-bit samples. The system clock can operate at 1MHz (lower power, better noise performance) or 4MHz (faster sample rates). The PreAmp nulls its offset over temperature and offers a wide range of selectable analog gain settings. The on-chip digital signal processor (DSP) core uses coefficients stored in EEPROM to precisely calibrate/condition the amplified differential input signal. Temperature can be measured from an internal temperature sensor, which can be calibrated and output as well as used to compensate for temperature effects of the sensor bridge.

Direct interfacing to  $\mu\text{P}$  controllers is facilitated via  $\text{I}^2\text{C}^{\text{TM}}$  digital protocol or optional SPI.  $\text{I}^2\text{C}^{\text{TM}}$  is used as the calibration interface and can be used in the final application. SPI is only supported for end applications.

**Figure 2.1 ZSC31014 Block Diagram**

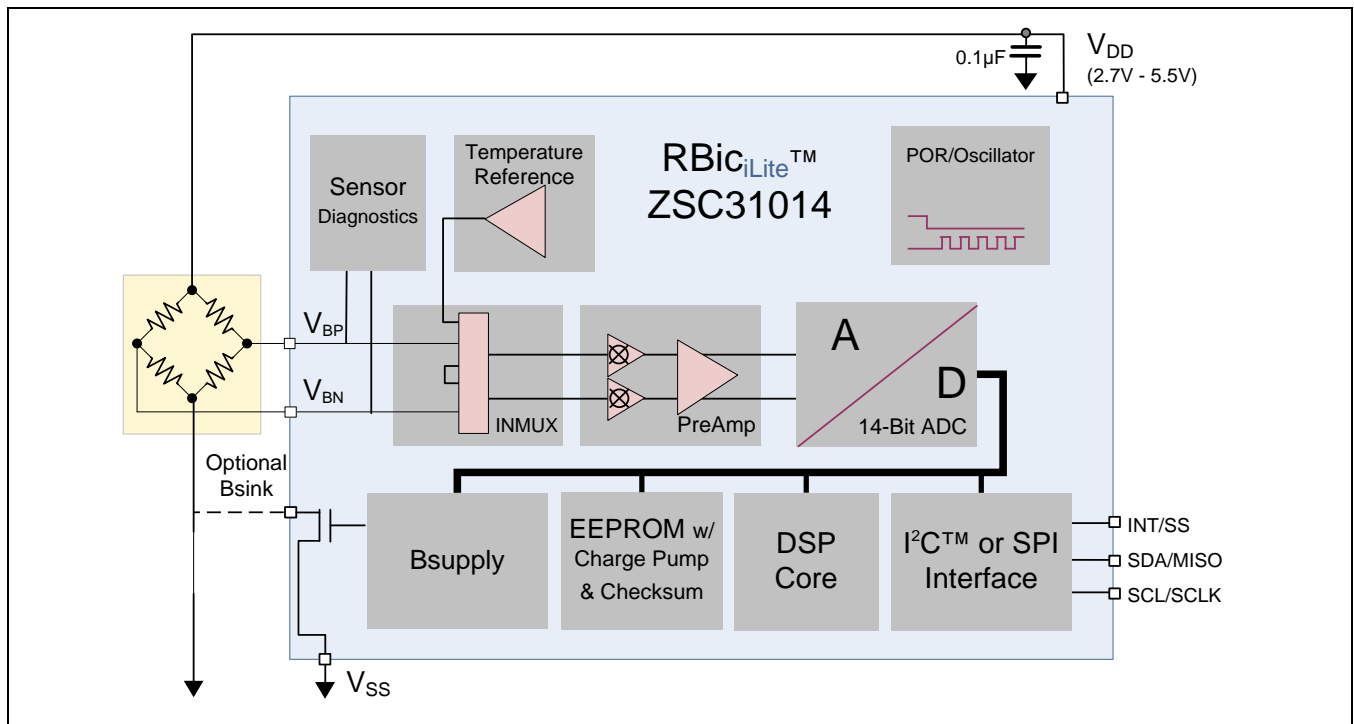

## 2.2. Analog Front End

### 2.2.1. Preamplifier (PreAmp)

The preamplifier has a chopper-stabilized two-stage design. The first stage instrumentation-type amplifier has an internal auto-zero (AZ) function in order to prevent the second stage from being overdriven by the amplified offset. The overall chopper guarantees that the whole PreAmp has negligible offset.

There are eight analog gain settings selectable in EEPROM. The polarity of the gain can be changed by shifting the chopper phase between input and output by 180 degrees via the EEPROM setting Gain\_Polarity. Changing the polarity can help prevent board layout crossings in cases where the sensor chip layout does not match the ZSC31014 pad/pin layout.

PreAmp\_Gain for the bridge measurement is controlled by bits [6:4] in EEPROM Word 0F<sub>HEX</sub> (B\_Config register). PreAmp\_Gain for temperature is set by bits [6:4] in Word 10<sub>HEX</sub> (T\_Config register). These 3 bits are referred to as [G2:G0]. See section 2.2.3 for recommended temperature measurements settings.

**Table 2.1 Preamplifier Gain Control Signals** †

G2	G1	G0	PreAmp_Gain
0	0	0	1.5
1	0	0	3
0	0	1	6
1	0	1	12
0	1	0	24
1	1	0	48
0	1	1	96
1	1	1	192

Gain Polarity for the bridge is controlled by bit [7] (Gain\_Polarity) in the B\_Config register.

**Table 2.2 Gain Polarity Control Signal**

Gain_Polarity	Overall Gain
0	(-1) * GAIN
1	(+1) * GAIN

† For previous silicon revision A, the available analog gain settings are 1 (G2:G0=000); 3 (G2:G0=100); 5 (G2:G0=001); 15 (G2:G0=101); 24 (G2:G0=010); 40 (G2:G0=011); 72 (G2:G0=110); and 120 (G2:G0=111).

Before a measurement conversion is started, the PreAmp has a phase called nulling. During the nulling phase, the PreAmp measures its internal offset so that it can be removed during the measurement. It is especially useful at higher gains where a small offset could cause the PreAmp to saturate. If bit[12] of the configuration register is set to one, then the nulling feature is disabled as shown in Table 2.3. At lower PreAmp gains, nulling can adversely affect the linearity and ratiometricity of the part, so the recommended setting for this bit is zero for gains of 6 or higher and one for all other gains.

**Table 2.3 Disable Nulling Control Signal**

Disable_Nulling	Effect
0	Nulling is on
1	Nulling is off

### 2.2.2. Analog-to-Digital Converter

A 14-bit 2<sup>nd</sup> order charge-balancing analog-to-digital converter (ADC, A2D) is used to convert signals coming from the PreAmp. By default, each conversion is split into a 9-bit coarse conversion and a 5-bit fine conversion. During the coarse conversion, the amplified signal is integrated (averaged). One coarse conversion covers exactly 4 chopper periods of the PreAmp. A configurable setting stored in EEPROM allows quadrupling the period of the coarse conversion. In Table 3.7, see the LongInt bit in EEPROM words B\_Config (0F<sub>HEX</sub>) and T\_Config (10<sub>HEX</sub>). When LongInt = 1, the conversion is performed as 11 bits coarse + 3 bits fine. The advantage of this mode is more noise suppression; however, sampling rates will fall significantly because A2D conversion periods are quadrupled.

An auto-zero (AZ) measurement is performed periodically and subtracted from all ADC results used in calculations. This compensates for any drift of offset vs. temperature. The ADC uses switched capacitor technique and complete full-differential architecture to increase its stability and noise immunity.

Part of the switched capacitor network is a 4-bit digital-to-analog conversion (DAC) function, which allows adding or subtracting a defined offset value resulting in an A2D\_Offset shift. This allows for a rough compensation of the bridge offset, which allows a higher PreAmp\_Gain to be used and consequently more end resolution of the measured signal. Table 2.4 shows the A2D\_Offset adjustment. Using this function, the ADC input range can be shifted in order to optimize the coverage of the sensor signal and sensor offset values as large as the sensor span can be processed without losing resolution.

The A2D\_Offset setting for the bridge is controlled by bits [3:0] in Word 0F<sub>HEX</sub> (B\_Config). These 4 bits are referred to as [Z3:Z0]. Note: To collect uncalibrated raw bridge values from the ADC, the Offset\_B coefficient must be programmed as shown in Table 2.4. Note: The ADC offset for the internal temperature measurement is trimmed at production test to avoid saturation and the setting, which is stored in bits [3:0] in word 10<sub>HEX</sub> (T\_Config), should not be changed (see Table 3.7).

**Table 2.4 A2D\_Offset Signals**

A2D_Offset[3:0]	Auto-Zero Output Count of A2D (+/- 250 Codes)	A2D Input Range [VREF]	A2D_Offset	Offset_B[15:0]
F <sub>HEX</sub>	15360	-15/16 to 1/16	15/16	1C00 <sub>HEX</sub>
E <sub>HEX</sub>	14336	-7/8 to 1/8	7/8	1800 <sub>HEX</sub>
D <sub>HEX</sub>	13312	-13/16 to 3/16	13/16	1400 <sub>HEX</sub>
C <sub>HEX</sub>	12288	-3/4 to 1/4	3/4	1000 <sub>HEX</sub>
B <sub>HEX</sub>	11264	-11/16 to 5/16	11/16	0C00 <sub>HEX</sub>
A <sub>HEX</sub>	10240	-5/8 to 3/8	5/8	0800 <sub>HEX</sub>
9 <sub>HEX</sub>	9216	-9/16 to 7/16	9/16	0400 <sub>HEX</sub>
8 <sub>HEX</sub>	8192	-1/2 to 1/2	1/2	0000 <sub>HEX</sub>
7 <sub>HEX</sub>	7168	-7/16 to 9/16	7/16	FC00 <sub>HEX</sub>
6 <sub>HEX</sub>	6144	-3/8 to 5/8	3/8	F800 <sub>HEX</sub>
5 <sub>HEX</sub>	5120	-5/16 to 11/16	5/16	F400 <sub>HEX</sub>
4 <sub>HEX</sub>	4096	-1/4 to 3/4	1/4	F000 <sub>HEX</sub>
3 <sub>HEX</sub>	3072	-3/16 to 13/16	3/16	EC00 <sub>HEX</sub>
2 <sub>HEX</sub>	2048	-1/8 to 7/8	1/8	E800 <sub>HEX</sub>
1 <sub>HEX</sub>	1024	-1/16 to 15/16	1/16	E400 <sub>HEX</sub>
0 <sub>HEX</sub> <sup>1)</sup>	0	0 to 16/16	0	E000 <sub>HEX</sub>

1) A setting of 0000<sub>BIN</sub> for the A2D offset can only be used for internal temperature measurements, which are factory-trimmed (do not change default setting). If it is used for bridge measurements, it could lead to the auto-zero saturating, which results in poor performance of the IC.

Figure 2.2 shows a functional diagram of the ADC. The A/D block at the right side is assumed to be an ideal differential ADC. The summing node B models the offset voltage, which is caused by the tolerance of process parameters and other influences including temperature and changes of power supply. The summing node A adds a voltage, which is controlled by the digital input A2D\_Offset. This internal digital-to-analog converter (DAC, D2A) uses binary-weighted capacitors, which are part of the switched capacitor network of the ADC. This DAC function allows optimal adjustment of the input voltage range of the ADC to the amplified output voltage range of the sensor. All signals in this diagram are shown as single-ended for simplicity in understanding the concept; all signals are actually differential. An auto-zero reading is accomplished by short-circuiting the differential ADC input.

Figure 2.2 Functional Diagram of the ADC

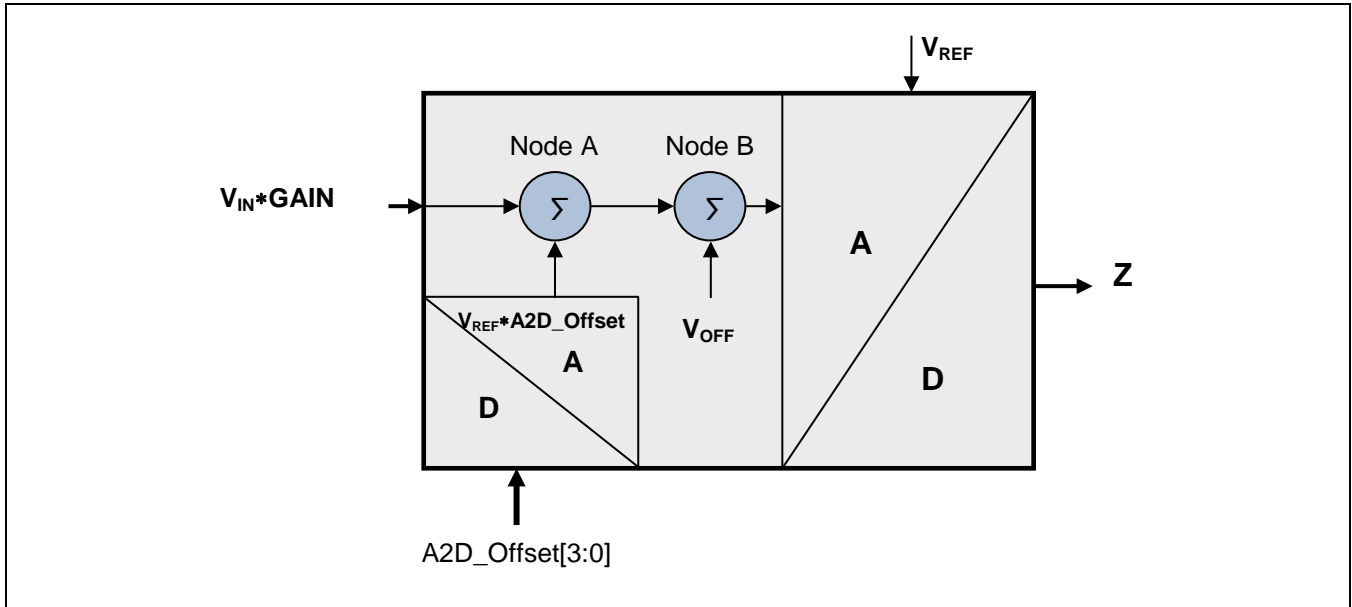

Digital representation of the input voltage as a signed number requires calculating the difference  $Z_{SENSOR} - Z_{AUTOZERO}$ .

$$Z_{SENSOR} = 2^{14} * (GAIN * V_{IN} / V_{DD} + A2D\_Offset + V_{OFF} / V_{REF}) \quad (1)$$

$$Z_{AUTOZERO} = 2^{14} * (A2D\_Offset + V_{OFF} / V_{REF}) \quad (2)$$

where

- GAIN** PreAmp\_Gain (B\_Config bits [6:4] for bridge measurement; fixed value 6 for temperature measurement) (See Table 2.1)
- A2D\_Offset** Zero Shift of ADC (B\_Config or T\_Config bits [3:0]) (See Table 2.4)
- V<sub>REF</sub>** ~ V<sub>DD</sub> Supply Voltage to ZSC31014
- V<sub>IN</sub>** Input Voltage = (V<sub>BP</sub>-V<sub>BN</sub>) in differential mode;  
= (V<sub>BP</sub>-V<sub>DD</sub>/2) in half-bridge mode
- V<sub>OFF</sub>** Small random offset voltage that varies part-to-part and with temperature. The periodic auto-zero cycle will subtract this error.

The digital output Z as a function of the analog input of the analog front-end (including the PreAmp) can be described as

$$Z = Z_{SENSOR} - Z_{AUTOZERO}$$

$$Z = 2^{14} * (GAIN * V_{IN} / V_{REF}) \quad (3)$$

With  $V_{REF} = V_{DD} - V_{BSink}$  (see section 2.2.4) where V<sub>BSink</sub> is the voltage at the BSINK pin.

### 2.2.3. Temperature Measurement

The temperature signal comes from an internal measurement of the die temperature. The temperature signal is generated from a bridge-type sensor using resistors with different TC values. Table 2.5 shows the characteristic parameters. This temperature signal can be corrected with offset, span, and 2<sup>nd</sup> order non-linearity coefficients. The corrected temperature can then be read on the digital output I<sup>2</sup>C™ or SPI with either an 8 or 11 bit resolution. The raw temperature reading can also be used to compensate the sensor bridge reading. 1<sup>st</sup> order Tco and Tcg, and 2<sup>nd</sup> order Tco and Tcg coefficients are available to correct sensor bridge offset and span variations with temperature.

**Table 2.5 Parameters of the Internal Temperature Sensor Bridge**

Parameter	Min	Typ	Max	Units
Sensitivity	0.28	0.38	0.5	mV/V/K
Offset voltage	-75		65	mV/V
Nonlinearity (-20 to 80°C) first order fit			2	°C
Nonlinearity (-20 to 80°C) second-order fit			0.25	°C
Bridge resistance	15	20	25	kΩ

**NOTE:** The T\_CONFIG register description is given in section 2.2.5. Most fields within this EEPROM register are programmed to default settings on the production test and should not be changed. Only the LongInt field (bit 8) setting is user-selectable if desired. Other settings for the remaining T\_Config bits might cause temperature measurements to saturate. Section 2.2.5 gives the details of how PreAmp\_Gain and A2D\_Offset Mode are configured for temperature measurements.

ZSC31014 on-chip temperature sensor is calibrated by IDT using three temperature points: -40°C, room temperature (RT), and +125°C, which provides a 2nd-order fit. The error of the conditioned temperature output data at delivery is specified as ≤ 2.5 Kelvin over the full operational temperature range of -40 to +125°C.

### 2.2.4. Bridge Supply (Bsink)

The ZSC31014 provides a Bsink (bridge sink) pin to drive the bottom of the sensor bridge. Internal to the ZSC31014, Bsink is driven by a large NMOS pull-down ( $R_{DS(ON)} \approx 20\Omega$ ). There will be some IR drop across this device, but the Bsink node also forms the bottom reference of the ADC. Therefore, any ratiometricity error this IR drop would normally cause is cancelled out.

Bsink is turned on 190μs/50μs (depending on 1MHz or 4MHz clock setting) prior to the start of a conversion to allow settling time for the bridge and the internal front-end (PreAmp and ADC) path. The entire conversion is then performed, and Bsink is then turned off. This can achieve significant power savings when used in conjunction with slower update rates. For example, a 2.5kΩ bridge would consume 2mA with a constant 5V bias. However, if used with the Bsink feature at an update rate of 6.35ms, the same bridge would draw on average only 112μA since it would be biased on only 5.6% of the time. Savings at slower update rates can be even more significant.

### 2.2.5. Analog Front-End Configuration

As shown in Figure 2.3, the analog front-end (AFE) has much flexibility/configurability in how its measurement is performed. The preferred settings for the AFE configuration are typically different for a bridge reading than for a temperature reading. The EEPROM contains two words for configuring the AFE for each measurement: B\_Config (0F<sub>HEX</sub>) and T\_Config (10<sub>HEX</sub>).

**Figure 2.3 Format for AFE Configuration Registers B\_Config and T\_Config**

Reserved [2:0]			Disable Nulling	PreAmp_Mux [1:0]		Bsink	LongInt	Gain_Polarity	PreAmp_Gain [2:0]			A2D_Offset [3:0]			
15	14	13		11	10				6	5	4	3	2	1	0

The B\_Config register is loaded from EEPROM and written to the AFE configuration register just before a measurement of the bridge begins. The T\_Config register is loaded from EEPROM and written to the AFE configuration register immediately before a temperature measurement begins. For more details, refer to Table 3.7, EEPROM words 0F<sub>HEX</sub> (B\_Config) and 10<sub>HEX</sub> (T\_Config), in section 3.6. Note: for T\_Config, only bit 8 (LongInt) is user-configurable. All other settings are factory programmed and should not be changed.

## 2.3. Digital Signal Processor

A digital signal processor (DSP) is used for processing the converted differential signal as well as performing temperature correction and computing the temperature value for digital output.

### 2.3.1. Digital Core

The digital core reads correction coefficients from EEPROM and can correct for the following:

1. Signal offset (Offset\_B term)
2. Signal gain (Gain\_B term)
3. Temperature coefficient of the bridge offset 1<sup>st</sup> order (Tco term)
4. Temperature coefficient of the bridge gain 1<sup>st</sup> order (Tcg term)
5. Second-order non-linearity of signal (SOT\_bridge term)
6. Second-order non-linearity of Tco (SOT\_tco term)
7. Second-order non-linearity of Tcg (SOT\_tcg term)

See sections 3.7 and 3.8 for a full discussion of calibration and correction math.

### 2.3.2. Normal Operation Mode

Two operation modes are available for normal operation: Update Rate Mode (continuous conversion at a selectable update rate) or Sleep Mode (low power). (See section 3.1.) Both modes can operate in either I<sup>2</sup>C™ digital output or SPI digital output. These selections are made in configuration registers of the EEPROM.

### 2.3.3. EEPROM

The EEPROM array contains the calibration coefficients for gain and offset, etc., and the configuration bits, such as output mode, update rate, etc. When programming the EEPROM, an internal charge pump voltage is used; therefore a high voltage supply is not needed. (See section 3.5 for instructions on programming the EEPROM.)

*Important:* After the ZMDI\_Config\_1 or ZMDI\_Config\_2 EEPROM word has been changed, the IC must be power cycled for the changes to be loaded.

The EEPROM array is arranged as twenty 16-bit words. Three words are dedicated to the customer serial number for module traceability. The integrity of the contents of the EEPROM array is ensured by a 16-bit signature word which is checked after each power-on of the device. The signature word is automatically updated whenever the Start\_NOM command (starts Normal Operating Mode; see section 3.5) is executed after EEPROM contents have been changed.

After calibration is completed and all coefficients are written to EEPROM, the user can lock the EEPROM so that no further writes can occur (see section 3.6 regarding EEP\_Lock, bits [15:13] of EEPROM word 02<sub>HEX</sub>).

**IMPORTANT:** Care must be taken when performing this function. After the command to lock EEPROM, the next command *must* be Start\_NOM so that the EEPROM checksum is calculated and written. If the part is power cycled instead, the lock will take effect, and the checksum will be wrong. In this case, the part will always output a diagnostic state, and since the EEPROM is permanently locked, it can never be recovered.

### 2.3.4. Digital Interface – I<sup>2</sup>C™

The IC can communicate via an addressable two-wire (I<sup>2</sup>C™) interface. Commands are available for the following:

- Sending calibration commands in Command Mode
- Starting measurements in Sleep Mode
- Reading data

The ZSC31014 uses an I<sup>2</sup>C™-compatible communication protocol<sup>†</sup> with support for the bit rates listed in Table 2.6.

**Table 2.6 Supported I<sup>2</sup>C™ Bit Rates**

Clock Setting	Bit Rates
4MHz	400kHz or 100kHz
1MHz	100kHz

See section 2.3.6 for clock setting details.

<sup>†</sup> For more details, refer to <http://www.standards.nxp.com> or other websites for this specification.

I<sup>2</sup>C™ is the protocol used during calibration (Command Mode). The ZSC31014 I<sup>2</sup>C™ slave address (00<sub>HEX</sub> to 7F<sub>HEX</sub>) is selected by bits [9:3] of EEPROM word 02<sub>HEX</sub>. If the communication lock pattern Comm\_lock (bits [5:3], EEPROM word 02<sub>HEX</sub>) is programmed to 011, the device will respond only to this address. Otherwise, the device will respond to all I<sup>2</sup>C™ addresses. The factory setting for I<sup>2</sup>C™ slave address is 28<sub>HEX</sub> with Comm\_lock set.

When programmed as an I<sup>2</sup>C™ device, the INT/SS pin operates as an interrupt. The INT pin rises when new output data is ready and falls when the next I<sup>2</sup>C™ communication occurs. It is most useful if the part is configured in Sleep Mode to indicate to the system that a new conversion is ready.

See Figure 2.4 for the I<sup>2</sup>C™ timing diagram and Table 2.7 for definitions of the parameters shown in the timing diagram.

**Table 2.7 I<sup>2</sup>C™ Parameters**

PARAMETER	SYMBOL	MIN	TYP	MAX	UNITS
SCL clock frequency	f <sub>SCL</sub>	100		400	kHz
Start condition hold time relative to SCL edge	t <sub>HDSTA</sub>	0.1			μs
Minimum SCL clock low width <sup>1)</sup>	t <sub>LOW</sub>	0.6			μs
Minimum SCL clock high width <sup>1)</sup>	t <sub>HIGH</sub>	0.6			μs
Start condition setup time relative to SCL edge	t <sub>SUSTA</sub>	0.1			μs
Data hold time on SDA relative to SCL edge	t <sub>HDDAT</sub>	0			μs
Data setup time on SDA relative to SCL edge	t <sub>SUDAT</sub>	0.1			μs
Stop condition setup time on SCL	t <sub>SUSTO</sub>	0.1			μs
Bus free time between stop condition and start condition	t <sub>BUS</sub>	2			μs

1) Combined low and high widths must equal or exceed minimum SCLK period.

**Figure 2.4 I<sup>2</sup>C™ Timing Diagram**

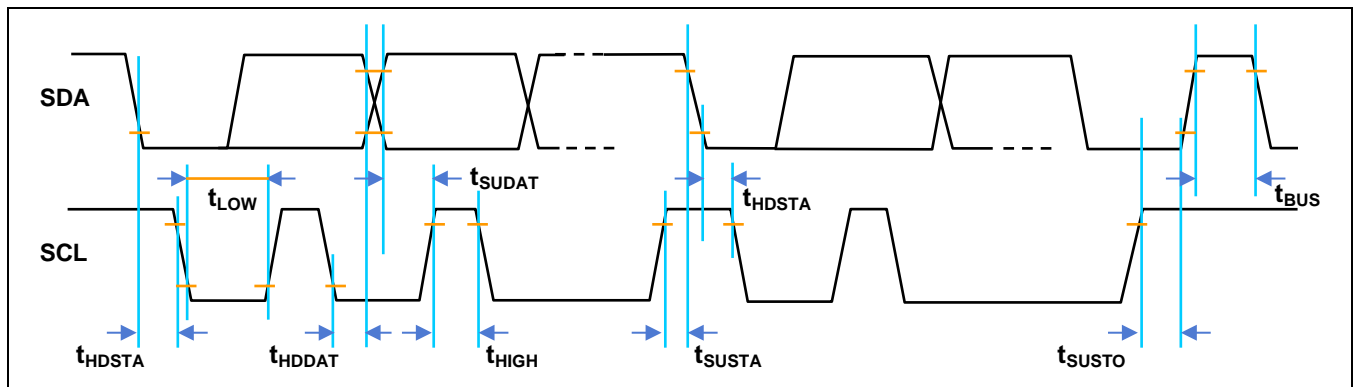

(See section 3.1 for data transmission details.)

Note: There are three differences in the ZSC31014 protocol compared with the original I<sup>2</sup>C™ protocol:

- Sending a start-stop condition without any transitions on the CLK line (no clock pulses in between) creates a communication error for the next communication, even if the next start condition is correct and the clock pulse is applied. An additional start condition must be sent, which results in restoration of proper communication.
- The restart condition—a falling SDA edge during data transmission when the CLK clock line is still high—creates the same situation. The next communication fails, and an additional start condition must be sent for correct communication.
- A falling SDA edge is not allowed between the start condition and the first rising SCL edge. If using an I<sup>2</sup>C™ address with the first bit 0, SDA must be held low from the start condition through the first bit.

### 2.3.5. Digital Interface – SPI

SPI is available only as half duplex (read-only from the ZSC31014). SPI cannot be used in the calibration environment (Command Mode) because it does not support receiving commands. SPI speeds of up to 200kHz can be supported in 1MHz Mode, and up to 800kHz can be supported in 4MHz Mode. See Figure 2.5 for the SPI timing diagram and Table 2.8 for definitions of the parameters shown in the timing diagram.

**Table 2.8 SPI Parameters**

PARAMETER	SYMBOL	MIN	TYP	MAX	UNITS
SCLK clock frequency (4MHz clock)	f <sub>SCL</sub>	50		800	kHz
SCLK clock frequency (1MHz clock)	f <sub>SCL</sub>	50		200	kHz
SS drop to first clock edge	t <sub>HDSS</sub>	2.5			μs
Minimum SCLK clock low width <sup>1)</sup>	t <sub>LOW</sub>	0.6			μs
Minimum SCLK clock high width <sup>1)</sup>	t <sub>HIGH</sub>	0.6			μs
Clock edge to data transition	t <sub>CLKD</sub>	0		0.1	μs
Rise of SS relative to last clock edge	t <sub>SUSS</sub>	0.1			μs
Bus free time between rise and fall of SS	t <sub>BUS</sub>	2			μs
1) Combined low and high widths must equal or exceed minimum SCLK period.					

**Figure 2.5 SPI Bus Data Output Timing**

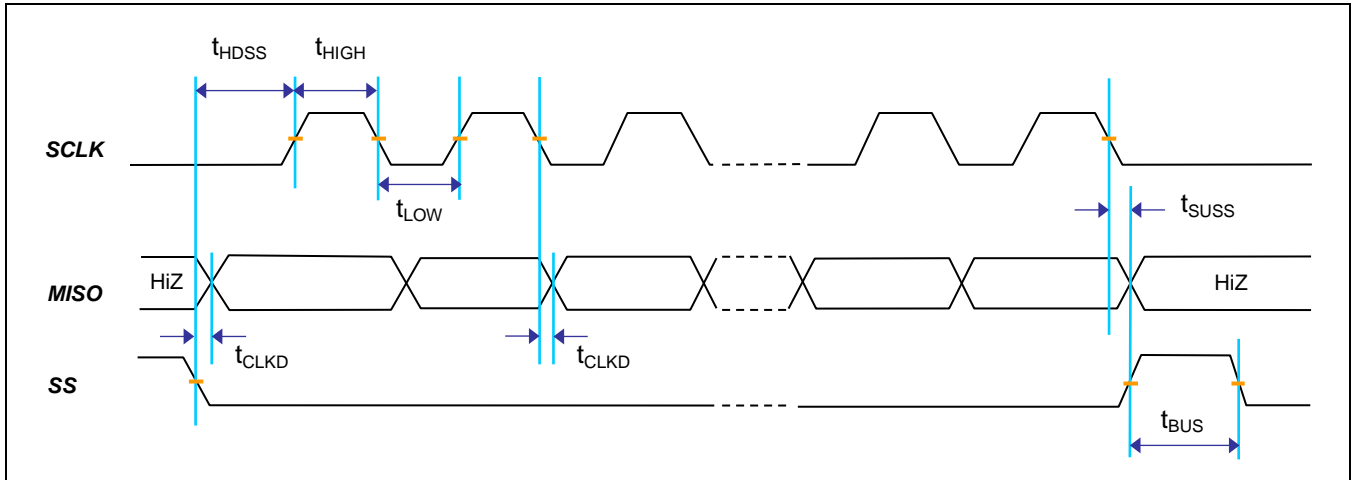

(See section 3.1 for data transmission details.)

**2.3.6. Clock Generator / Power-On Reset (CLKPOR)**

The ZSC31014 has an internal 4MHz temperature-compensated oscillator that provides the time base for all operations. This oscillator feeds into a 4:1 post scalar that can optionally form the clock source for the device. Using ClkSpeed (bit 3 of EEPROM word 01<sub>HEX</sub>; see section 3.6) the user can select a 4MHz clock or a 1MHz digital core clock for the ZSC31014. If the fast response times and sampling periods provided by the 4MHz clock are not needed, then choosing the 1MHz clock will result in better noise performance.

If the power supply exceeds the power-on reset level (see Table 1.3), the reset signal de-asserts and the clock generator starts working at the selected frequency (approximately 1MHz or 4MHz). The exact value only influences the conversion cycle time. To minimize the oscillator error as the V<sub>DD</sub> voltage changes, an on-chip regulator supplies the oscillator block.

**2.4. Diagnostic Features**

The ZSC31014 offers a full suite of diagnostic features to ensure robust system operation in the most “mission-critical” applications. The diagnostic states are indicated by a transmission of the status of the 2 MSBs of the bridge high byte data.

**Table 2.9 2 MSB of Data Packet Encoding**

Status Bits (2 MSBs of Output Packet)	Definition
00	Normal operation, good data packet
01	Device in Command Mode
10	Stale data: Data that has already been fetched since the last measurement cycle. <b>Note:</b> If a data fetch is performed before or during the first measurement after power-on reset, then “stale” will be returned, but this data is actually invalid because the first measurement has not been completed.
11	Diagnostic condition exists

When the two MSBs are 11, one of the following faults listed below is indicated.

- Invalid EEPROM signature
- Loss of bridge positive or negative
- Bridge input short
- Loss of bridge source
- Loss of bridge sink

All diagnostics are detected in the next measurement cycle and reported in the subsequent data fetch. Once a diagnostic is reported, the diagnostic status bits will not change unless both the cause of the diagnostic is fixed and a power-on-reset is performed.

### **2.4.1. EEPROM Integrity**

The contents of the EEPROM are protected by a 16-bit signature generated by a multiple input shift register (MISR). This signature is generated and stored in EEPROM (word 12<sub>HEX</sub>) upon leaving Command Mode if an EEPROM write has occurred. This signature is re-generated and checked for a match after Power-On-Reset prior to entering Normal Operation Mode. If the generated signature fails to match, the part will output a diagnostic state on the output. The customer ID fields (words 00<sub>HEX</sub>, 0E<sub>HEX</sub>, and 13<sub>HEX</sub>) are not included in the signature.

### **2.4.2. Sensor Connection Check**

Four dedicated comparators constantly check the range of the bridge inputs (BP/BN) to ensure they are within the envelope of 0.15\*VDD to 0.85\*VDD during all conversions. The two sensor inputs have switched ohmic paths to ground and if not driven, would discharge during the fine conversion phase. If any of the connections to the bridge break, this mechanism will detect it and put the ASIC in a diagnostic state. This diagnostic feature can be enabled/disabled with bit 0 of Diag\_cfg (bits [2:1] of EEPROM word 02<sub>HEX</sub>).

### **2.4.3. Sensor Short Check**

If a short occurs between BP/BN (bridge inputs), it would normally produce a mid-range output signal and therefore would not be detected as a fault. If enabled via bit 1 of Diag\_cfg (bits [2:1] of EEPROM word 02<sub>HEX</sub>), the sensor short diagnostic detects BP/BN shorts. After the measurement cycle of the bridge, it will deliberately pull the BP bridge input to ground for 8μsec with a 1MHz clock or 2μsec with a 4MHz clock. At the end of this 8μsec/2μsec window, it will check to see if the BN input “followed” it down below the 15%VDD comparator check point. If so, a short must exist between BP/BN, and the part will output a diagnostic state. The bridge will have a minimum recovery time of 100 μsec for a 1MHz clock or 25 μsec for a 4MHz clock prior to the next measurement.

## 3 Functional Description

### 3.1. General Working Mode

See Figure 3.1 for an overview of the general working mode of the ZSC31014. There are three types of commands as detailed in Table 3.1.

**Table 3.1 Command Types**

Type	Description	Communication Supported	Reference Sections
Data Fetch (DF)	Used to fetch data in any mode	I <sup>2</sup> C™ and SPI	Sections 3.2.2 and 3.3.2
Measurement Request (MR)	Used to start measurements in Sleep Mode	I <sup>2</sup> C™ and SPI	Sections 3.1.2, 3.3.1, and 3.4.1
Calibration Commands	Used to calibrate part in Command Mode	I <sup>2</sup> C™ Only	Section 3.5

On system power-on reset (POR), the ZSC31014 wakes as an I<sup>2</sup>C™ device regardless of the digital protocol programmed in EEPROM. It then waits for a Start\_CM command for 6ms if EEPROM is unlocked or for 1.5ms if EEPROM is locked (the command window). If the ZSC31014 receives the Start\_CM command during the command window, it goes into Command Mode. The communication protocol in Command Mode is always I<sup>2</sup>C™ regardless of the setting programmed in EEPROM. During Command Mode, the device executes commands sent by the I<sup>2</sup>C™ master. Command Mode is primarily used in the calibration environment. See section 3.5 for details on Command Mode. The part remains in Command Mode until it receives the Start\_NOM command, which starts the Normal Operation Mode.

If instead during the power-on sequence, the command window expires without receiving a Start\_CM, the device will immediately assume its programmed output mode (I<sup>2</sup>C™ or SPI) and start performing the required A2D conversions (Temp, AZ, Bridge). When Update Mode has been selected, the first corrected data will be written to the digital interface within 6ms of power-on with a 1MHz clock and the EEPROM locked.

Operation after the power-on sequence depends on whether the part is programmed in Sleep Mode or in Update Mode. In Sleep Mode, the part waits for commands from the master before taking measurements. In Update Mode, data is taken at a fixed, selectable rate. More detail is given about Update Mode and Sleep Mode in sections 3.1.1 and 3.1.2 respectively.

Figure 3.1 General Working Mode

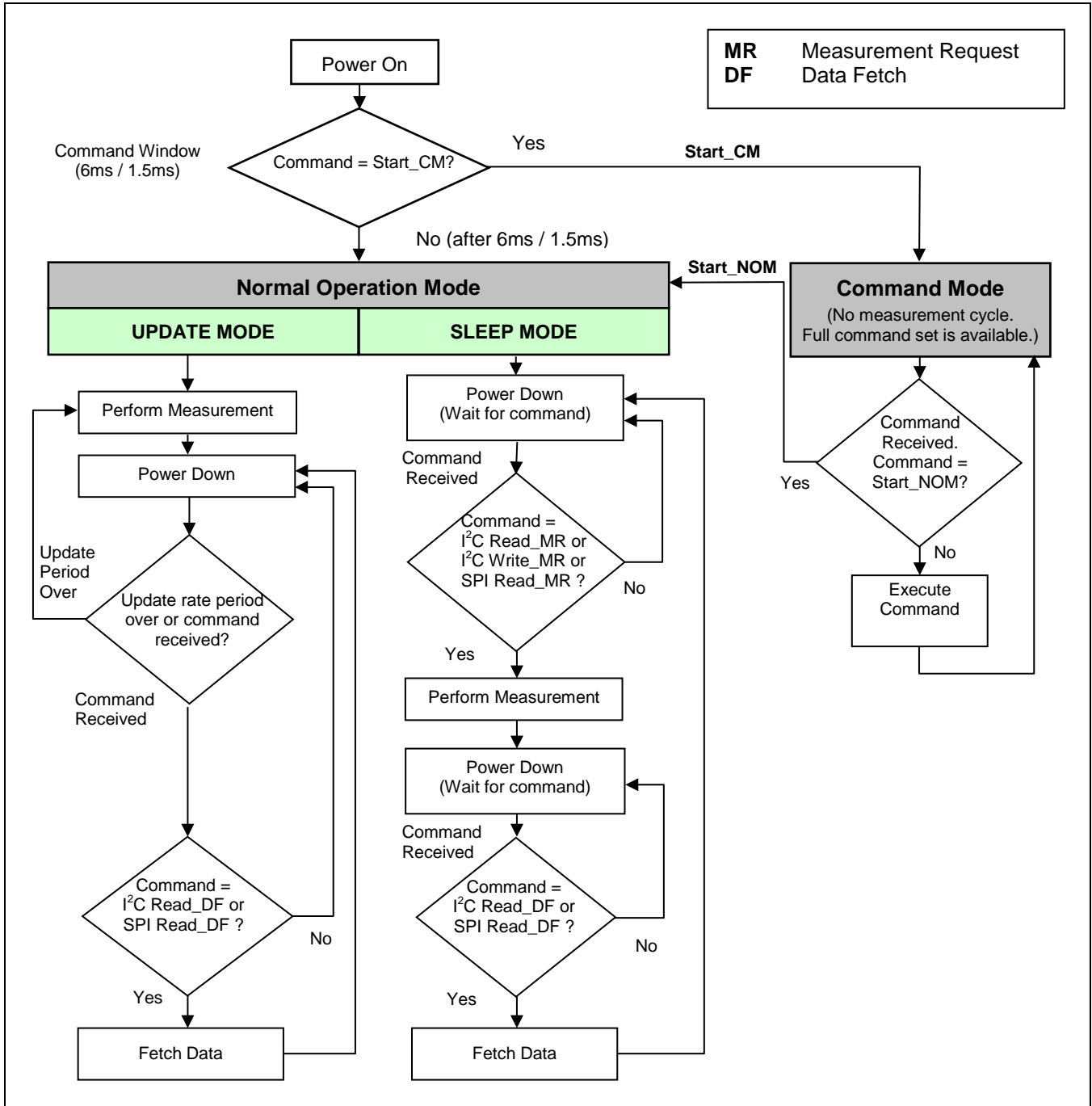

### 3.1.1. Update Mode

In Update Mode, the digital core will perform measurements and correction calculations at a selectable update rate and update the I<sup>2</sup>C™/SPI output register. The power-on measurement sequence for the Update Mode is shown in Figure 3.2.

**Figure 3.2 Power-Up Sequence and Timing for Update Mode with EEPROM Locked <sup>§</sup>**

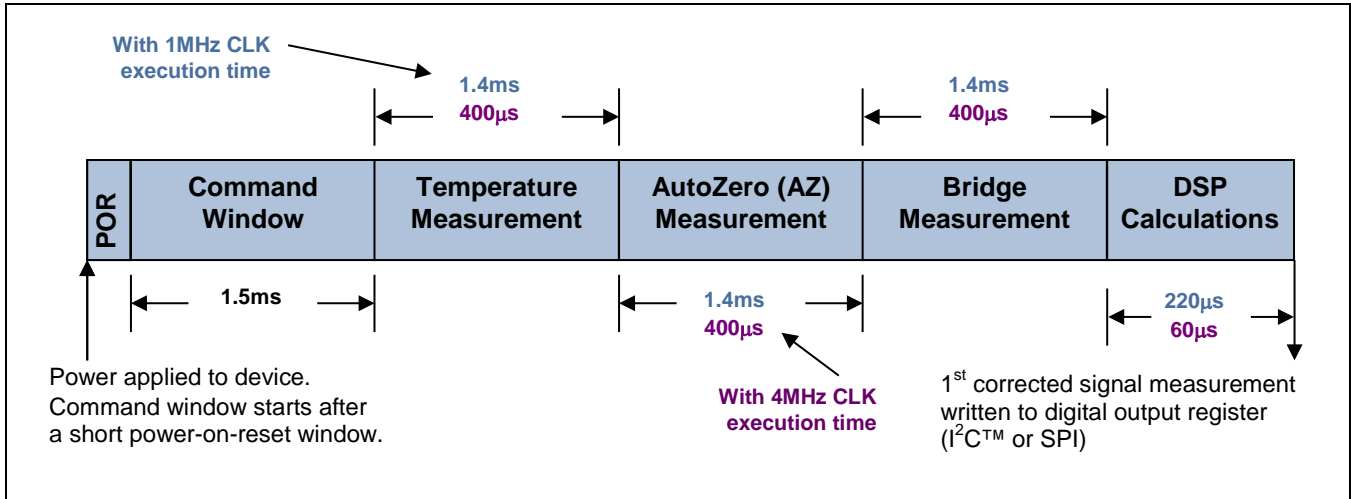

If the part is programmed for the fastest update rate, conversions will continue to happen after the power-up sequence. If the ZSC31014 is not in the fastest update rate, the part will power down after writing to the digital output register. The duration of the power-down period is determined by the Update\_Rate setting (bits [7:6] in EEPROM word 01<sub>HEX</sub>; see section 3.6) and the digital core clock speed (see section 2.3.6). See Table 3.2 and Table 3.3 for the update rates. After the power-down period has expired, the ZSC31014 will power up; take another *bridge* reading followed by calculations; write to the digital output register; and power down. Temperature and Auto-Zero (AZ) are slower moving quantities but must be updated periodically. When the part is configured in Update Mode, these two quantities are measured periodically (referred to as special measurements).

As illustrated in Figure 3.3, valid data output to the digital register occurs after the measurement and the DSP calculations are complete. At this point the master can fetch the data in I<sup>2</sup>C™ or SPI with a Read\_DF command. Specifics of the Read\_DF command are given in sections 3.2 and 3.3. After a valid output has been read by the master, the status bits are set to “stale,” indicating that the measurement has not been updated since the last Read\_DF. This mode allows the application to simply read the digital output at any time and be assured the data is no older than the selected update period. See Table 2.9 for more information on the status bits. The chip should be polled at a frequency slower than 20% more of the update rate period listed in Table 3.2 and Table 3.3.

In I<sup>2</sup>C™ Mode only, the INT/SS pin will assume the INT (interrupt) function. Instead of polling until a “valid” response is received, the application can look for a rise on the INT pin. This will indicate that the measurement and calculations are complete and new valid data is ready to be read on the I<sup>2</sup>C™ interface.

<sup>§</sup> When EEPROM is not locked, the command window is 4.5ms longer (= 6ms). All time values shown are typical; for the worst case values, multiply by 1.15 (nominal frequency ±15%).

**Table 3.2 Update Rate Settings (Normal Integration Mode: 9 Coarse + 5 Fine)**

Update_Rate	Update Period/1MHz Clock <sup>1)</sup>	Update Period/4MHz Clock <sup>1)</sup>	Measurement Cycles between Special Measurements (Temperature or AZ)
00 <sup>2)</sup>	1.6ms	0.5ms	255
01	5.0ms	1.5ms	127
10	25.0 ms	6.5ms	31
11	125.0ms	32.0ms	15

1) All time values shown are typical; for worst case values, multiply by 1.15 (nominal frequency  $\pm 15\%$ ).  
 2) With the fastest update rate setting, there is no power down period between measurements.

**Table 3.3 Update Rate Settings (Long Integration Mode: 10 Coarse + 5 Fine)**

Update_Rate	Update Period/1MHz Clock <sup>1)</sup>	Update Period/4MHz Clock <sup>1)</sup>	Number of Measurement Cycles between Special Measurements (Temperature or AZ)
00 <sup>2)</sup>	5ms	1.5ms	255
01	8.5ms	2.5ms	127
10	30.0ms	7.5ms	31
11	130.0ms	33.0ms	15

1) All time values shown are typical; for worst case values, multiply by 1.15 (nominal frequency  $\pm 15\%$ ).  
 2) With the fastest update rate setting, there is no power down period between measurements.

**Figure 3.3 Measurement Sequence in Update Mode**

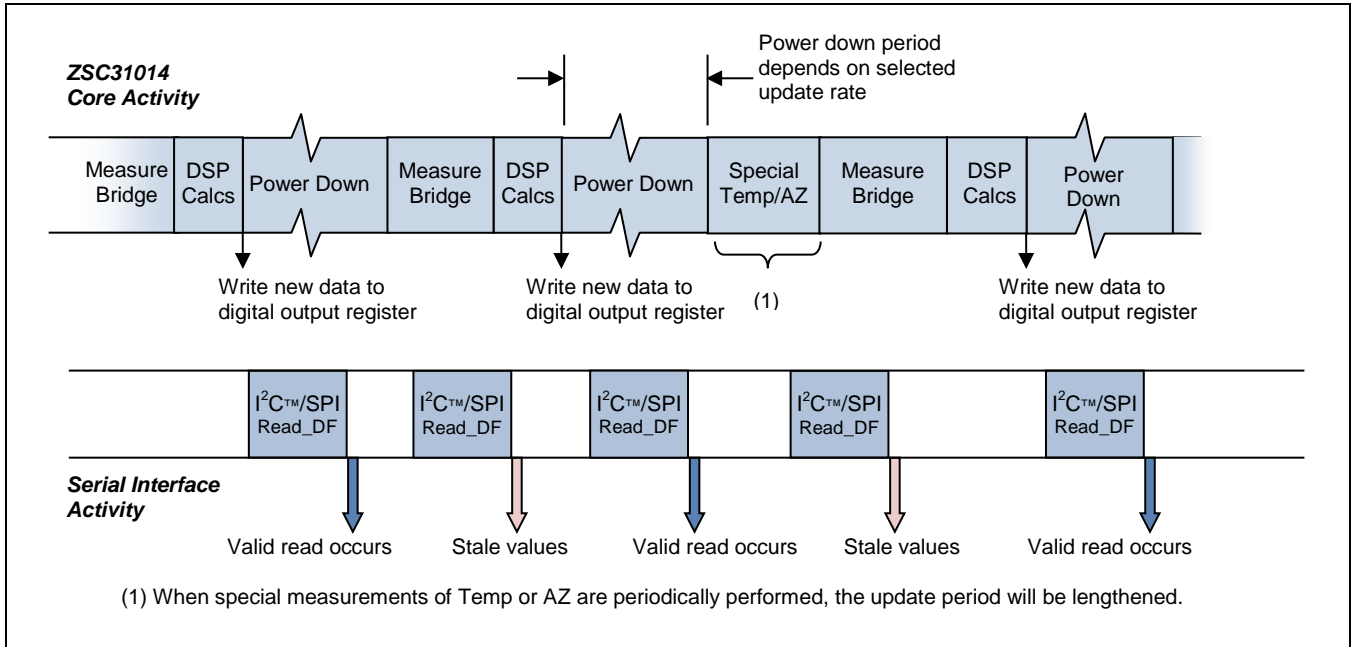

The benefit of slower update rates is power savings. If the update period is increased, the device will be powered down for longer periods of time, so power consumption will be reduced. When a special measurement occurs, a BP/BN (bridge) measurement will occur directly afterward. The update period during this special measurement will be increased by one conversion time over the standard measurement period.

### 3.1.2. Sleep Mode

In Sleep Mode, after the command window, the ZSC31014 will power down until the master sends a Read\_MR (either I<sup>2</sup>C™ or SPI) or a Write\_MR (I<sup>2</sup>C™ only). Specifics on the Read\_MR and Write\_MR commands are given in sections 3.2.1, 3.3.1, and 3.4.1. A Read\_MR or Write\_MR wakes the ZSC31014 and starts a measurement cycle. If the command is Read\_MR, the part performs temperature, auto-zero (AZ), and a bridge measurement followed by the DSP correction calculations (see Figure 3.4). If the command is Write\_MR, the part measures only the bridge and performs the correction calculations using previously measured temperature and auto-zero data (see Figure 3.5). Valid values are then written to the digital output register, and the ZSC31014 powers down again.

Following a measurement sequence and before the next measurement can be performed, the master must send a Read\_DF command, which will fetch the data as 2, 3 or 4 bytes (see section 3.2.2), without waking the ZSC31014. When a Read\_DF is performed, the data packet returned will be the last measurement made with the status bits set to "valid." See Table 2.9 for more information on the status bits. After the Read\_DF is completed, the status bits will be set to "stale." The next Read\_MR or Write\_MR will wake the part again and start a new measurement cycle. If a Read\_DF is sent while the measurement cycle is still in progress, then the status bits of the packet will read as "stale." The chip should be polled at a frequency slower than 20% more than the Sleep Mode response times listed in Table 3.4 and Table 3.5.

**Note:** Data is considered invalid from system power-on reset (POR) until the first measured data is written to the digital register. Sending an I<sup>2</sup>C™ Write\_MR as the first command after power-on delivers invalid data; even though the status bits report it as “valid”. This is due to the correction calculations being performed with an uninitialized temperature and Auto-Zero value.

In I<sup>2</sup>C™ Mode only, the INT/SS pin will assume the INT (interrupt) function. Instead of polling until a “valid” response is received, the application can look for a rise on the INT pin. This will indicate that the measurement and calculations are complete, and new valid data is ready to be read on the I<sup>2</sup>C™ interface.

**Table 3.4 Sleep Mode Response Times (Normal Integration Mode: 9 Coarse + 5 Fine)**

Measurement Request	Response/1MHz Clock <sup>1)</sup>	Response/4MHz Clock <sup>1)</sup>
Read MR	4.5ms	1.5ms
Write MR	1.5 ms	0.5ms
1) All time values shown are typical; for worst case values, multiply by 1.15 (nominal frequency ±15%).		

**Table 3.5 Sleep Mode Response Times (Long Integration Mode: 10 Coarse + 5 Fine)**

Measurement Request	Response/1MHz Clock <sup>1)</sup>	Response/4MHz Clock <sup>1)</sup>
Read MR	12ms	4.5ms
Write MR	5.5 ms	1.5ms
1) All time values shown are typical; for worst case values, multiply by 1.15 (nominal frequency ±15%).		

**Figure 3.4 Power-on Sequence in Sleep Mode for I<sup>2</sup>C™ or SPI Read\_MR (Typical Timing Values\*\*)**

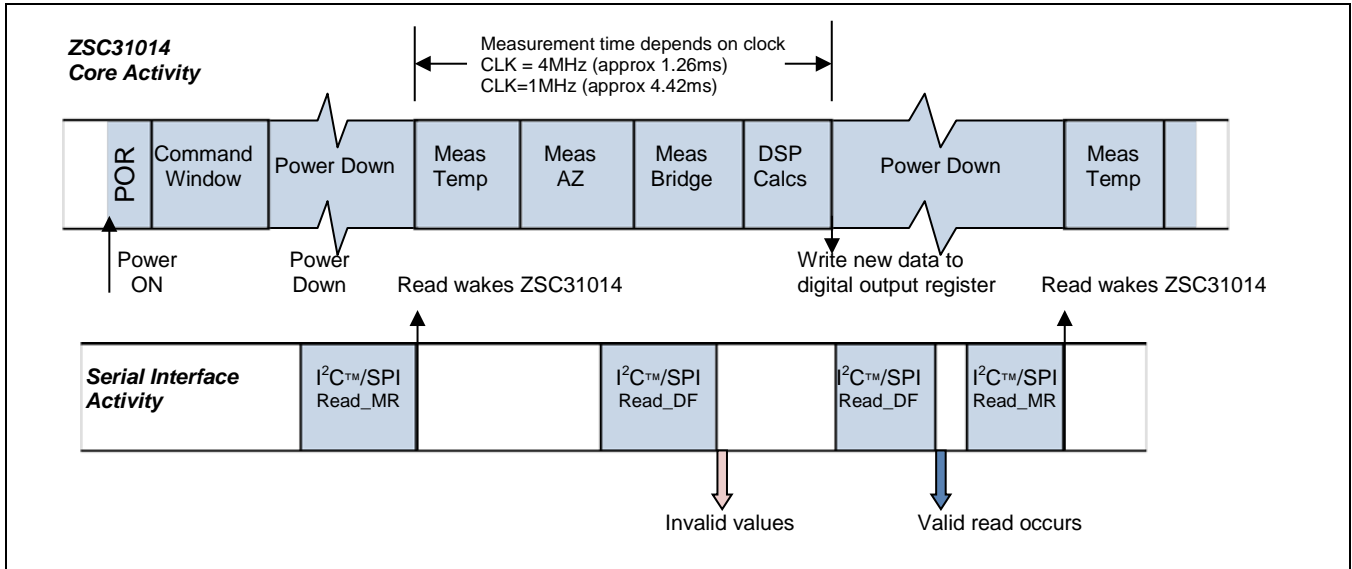

**Figure 3.5 Sequence during Sleep Mode Using an I<sup>2</sup>C™ Write\_MR to Wake Up (Typical Timing Values\*\*)**

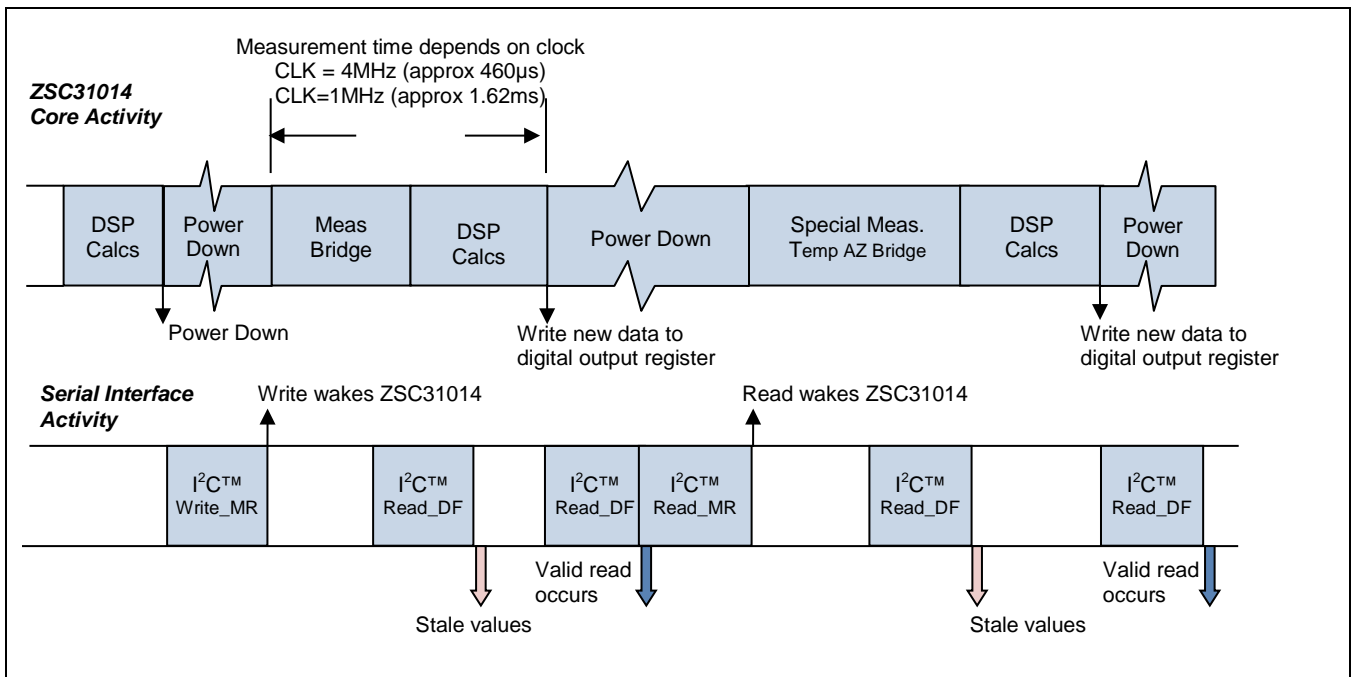

\*\* All time values shown are typical; for worst case values, multiply by 1.15 (nominal frequency ±15%).

### 3.2. ZSC31014 Read Operations with I<sup>2</sup>C™

For read operations, the I<sup>2</sup>C™ master command starts with the 7bit slave address with the 8<sup>th</sup> bit =1 (READ). The ZSC31014 as the slave sends an acknowledge (ACK) indicating success. The ZSC31014 has four I<sup>2</sup>C™ read commands: Read\_MR, Read\_DF2, Read\_DF3, and Read\_DF4. Figure 3.6 shows the structure of the measurement packet for three of the four I<sup>2</sup>C™ read commands, which are explained in sections 3.2.1 and 3.2.2.

Figure 3.6 I<sup>2</sup>C™ Measurement Packet Reads

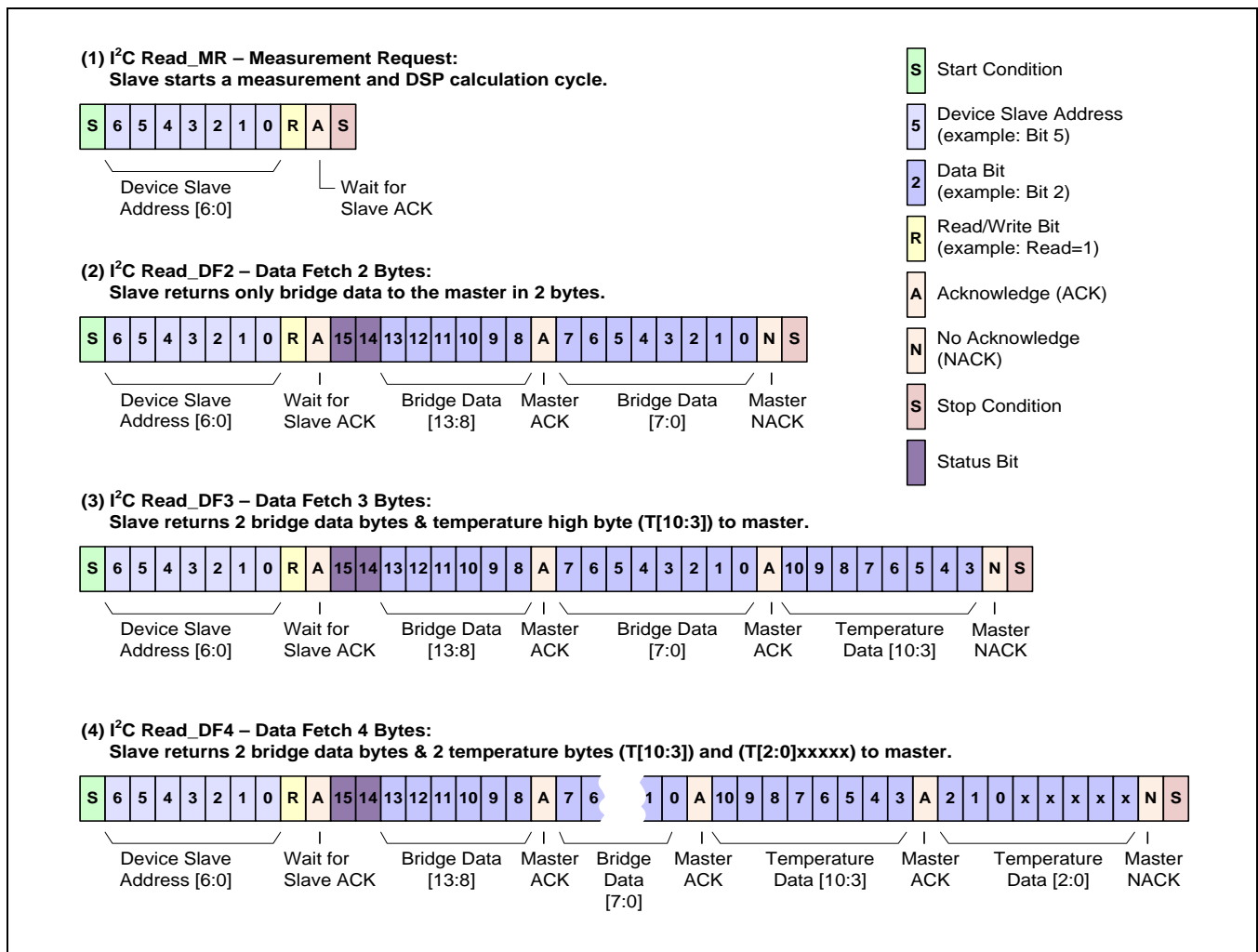

### 3.2.1. I<sup>2</sup>C™ Read\_MR (Measurement Request)

The Read\_MR (see example 1 in Figure 3.6) communication contains only the slave address and the READ bit (1) sent by the master. After the ZSC31014 responds with the slave ACK, the master must create a stop condition. This is only used in Sleep Mode (see section 3.1.2) to wake up the device and start a complete measurement cycle (including the special measurements) followed by the DSP calculations and writing the results to the digital output register.

Note: The I<sup>2</sup>C™ Read\_MR function can also be accomplished using the I<sup>2</sup>C™ Read\_DF2 or Read\_DF3 command and ignoring the “stale” data that will be returned.

### 3.2.2. I<sup>2</sup>C™ Read\_DF (Data Fetch)

For Data Fetch commands, the number of data bytes returned by the ZSC31014 is determined by when the master sends the NACK and stop condition. For the Read\_DF3 data fetch command (Data Fetch 3 Bytes; see example 3 in Figure 3.6), the ZSC31014 returns three bytes in response to the master sending the slave address and the READ bit (1): two bytes of bridge data with the two status bits as the MSBs and then 1 byte of temperature data (8-bit accuracy). After receiving the required number of data bytes, the master sends the NACK and stop condition to terminate the read operation.

For the Read\_DF4 command, the master delays sending the NACK and continues reading an additional final byte to acquire the full corrected 11-bit temperature measurement. In this case, the last 5 bits of the final byte of the packet are undetermined and should be masked off in the application.

The Read\_DF2 command is used if corrected temperature is not required. The master terminates the READ operation after the two bytes of bridge data (see example 2 in Figure 3.6).

## 3.3. SPI Read Operations

The SPI interface of ZSC31014 can be programmed for falling-edge MISO change or rising-edge MISO change (see SPI\_Polarity, bit 0 of EEPROM word 02<sub>HEX</sub>, in section 3.6).

### 3.3.1. SPI Read\_MR (Measurement Request)

A special SPI Read\_MR command is used for waking up the part in Sleep Mode (see section 3.1.2). It performs a measurement cycle including the special measurements and a correction calculation. The SPI Read\_MR command only requires that the SS line be dropped low for a minimum of 8μs then raised high again. The rise of SS will trigger the part to power up and perform the measurements.

Figure 3.7 SPI Read\_MR

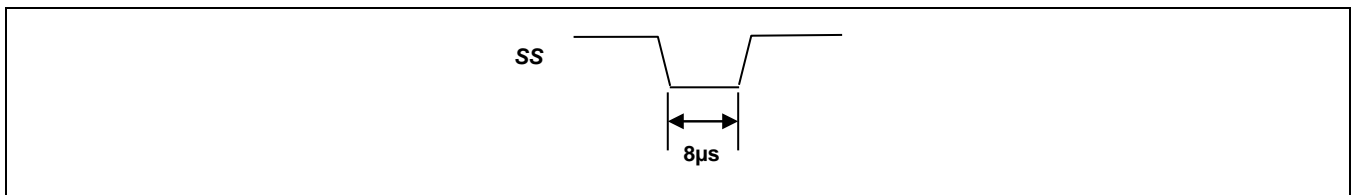

Note: The SPI Read\_MR function can also be accomplished using the SPI Read\_DF command (refer to section 3.3.2) and ignoring the “stale” data that will be returned.

### 3.3.2. SPI Read\_DF (Data Fetch)

For simplifying explanations and illustrations, only falling edge SPI polarity will be discussed in the following sections. The SPI interface will have data change after the falling edge of SCLK. The master should sample MISO on the rise of SCLK. The entire output packet is 4 bytes (32 bits). The high bridge data byte comes first, followed by the low bridge data byte. Then 11 bits of corrected temperature (T[10:0]) are sent: first the T[10:3] byte and then the {T[2:0],xxxxx} byte. The last 5 bits of the final byte are undetermined and should be masked off in the application. If the user only requires the corrected bridge value, the read can be terminated after the 2<sup>nd</sup> byte. If the corrected temperature is also required but only at an 8-bit resolution, the read can be terminated after the 3<sup>rd</sup> byte is read.

**Figure 3.8 SPI Output Packet with Falling Edge SPI\_Polarity**

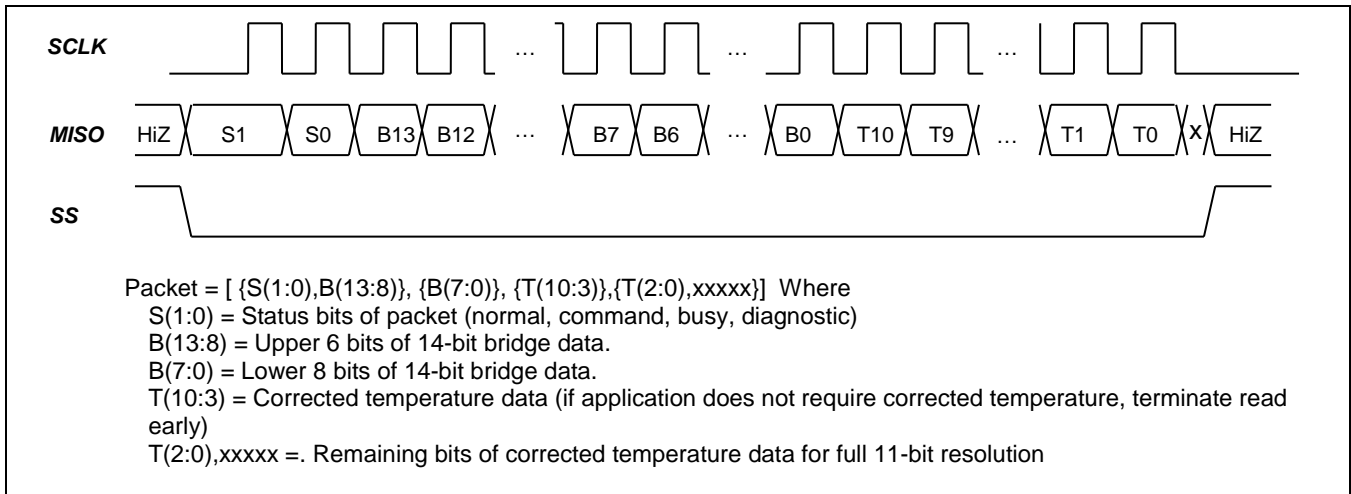

### 3.4. I<sup>2</sup>C™ Write Operations

For write operations, the I<sup>2</sup>C™ master command starts with the 7-bit slave address with the 8<sup>th</sup> bit =0 (WRITE). The ZSC31014 as the slave sends an acknowledge (ACK) indicating success. The ZSC31014 has two general I<sup>2</sup>C™ write command formats: I<sup>2</sup>C™ WRITE and I<sup>2</sup>C™ Write\_MR. Figure 3.9 shows the structure of the write packet for the two I<sup>2</sup>C™ write commands, which are explained in sections 3.4.1 and 3.4.2.

Figure 3.9 I<sup>2</sup>C™ Measurement Packet Writes

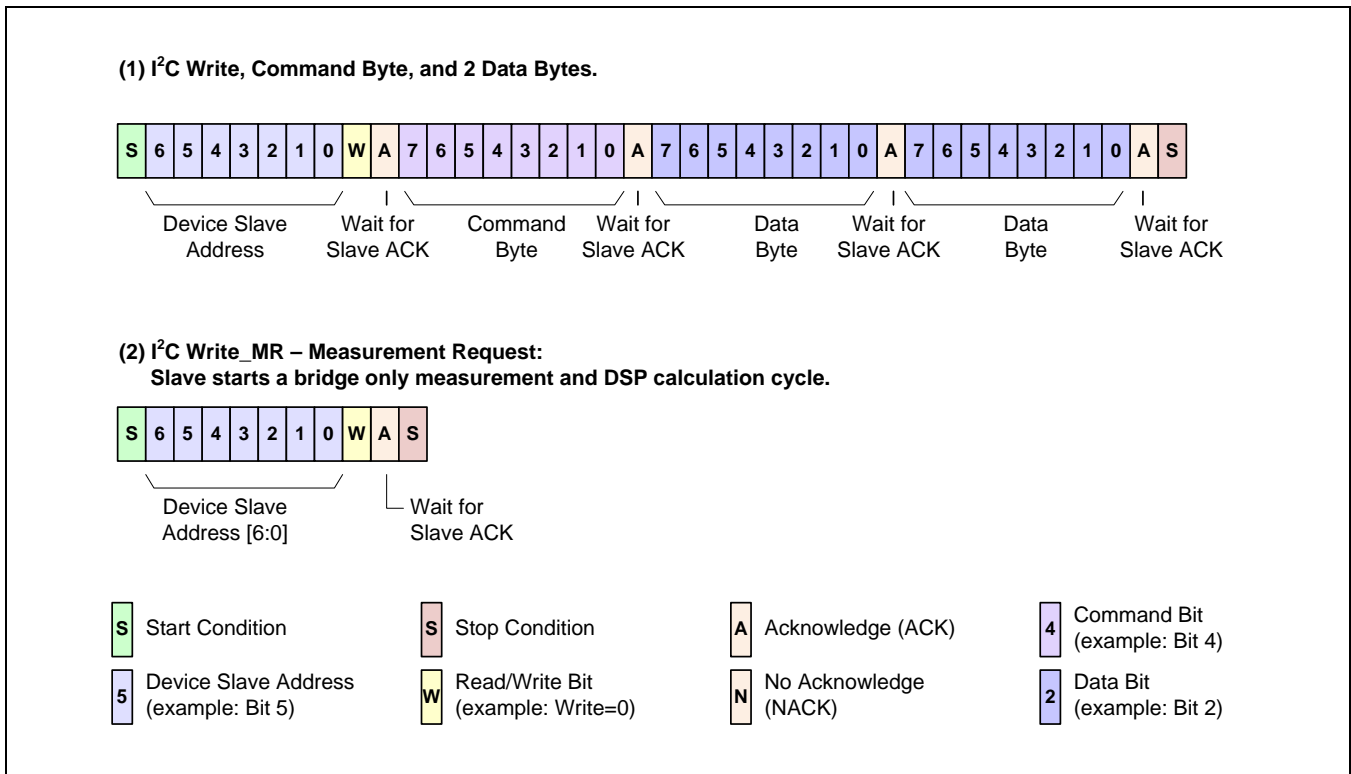

#### 3.4.1. I<sup>2</sup>C™ Write\_MR (Measurement Request)

Write\_MR is a special I<sup>2</sup>C™ write operation, which only includes the 7-bit slave address and the WRITE bit (0). This command can only be sent in Sleep Mode (see section 3.1.2). It wakes up the part and starts a measurement cycle for the bridge values only (no special measurement) and a DSP calculation based on former AZ and Temperature values. After finishing the calculation with valid results written to the digital register, the ZSC31014 powers down again and a Read\_DF (see section 3.2.2) is required to read the valid values. See Figure 3.9 for an illustration of Write\_MR.

Note: The I<sup>2</sup>C™ Write\_MR function can also be accomplished using the I<sup>2</sup>C™ WRITE command with “don’t care” data in Sleep Mode.

### 3.4.2. Command Mode I<sup>2</sup>C™ Write Operations

With the exception of the I<sup>2</sup>C™ Write\_MR command, write operations typically only occur in Command Mode (see section 3.1) and are only supported for the I<sup>2</sup>C™ protocol. Command Mode write commands to the ZSC31014 are in 32-bit packets. After the write command byte (7-bit slave address followed by 0 for write), the next (2<sup>nd</sup>) byte is considered the command byte, and the subsequent two bytes form a 16-bit data field. See Figure 3.9 for an illustration of the Command Mode I<sup>2</sup>C™ WRITE command sequence.

Note: If data is not needed for the command, all zeros must be supplied as data to complete the 32-bit packet.

### 3.5. Command/Data Pair Encoding in Command Mode

In Command Mode (see section 3.1), the master uses the I<sup>2</sup>C™ protocol to send 4-byte commands to the ZSC31014 (see section 3.4.2). Table 3.6 shows the available commands with their description and encodings.

Note: Only the commands listed in Table 3.6 below are valid for the ZSC31014 in Command Mode. Other encodings might cause unpredictable results. If data is not needed for the command, zeros must be supplied as data to complete the 32-bit packet.

**Table 3.6 Command List and Encodings**

Command Byte 8 Command Bits (Hex)	Third and Fourth Bytes 16 Data Bits(Hex)	Description	Processing Time †† 4MHz/1MHz
00 <sub>HEX</sub> to 13 <sub>HEX</sub>	0000 <sub>HEX</sub>	EEPROM Read of addresses 00 <sub>HEX</sub> to 13 <sub>HEX</sub> . After this command has been sent and executed, a data fetch of three bytes must be performed. The first byte will be a response byte, which should be a 5A <sub>HEX</sub> , and then the next two bytes will be the EEPROM data.	10µs
40 <sub>HEX</sub> to 53 <sub>HEX</sub>	YYYY <sub>HEX</sub> (Y= data)	Write to EEPROM addresses 00 <sub>HEX</sub> to 13 <sub>HEX</sub> . If the command is an EEPROM write, then the 16 bits of data sent will be written to the address specified in the 6 LSBs of the command byte.	15ms
80 <sub>HEX</sub>	0000 <sub>HEX</sub>	Start_NOM => Ends Command Mode and transitions to Normal Operation Mode. When a Start_NOM command is executed, a flag is checked to see if EEPROM was programmed during Command Mode. If so, the device will regenerate the checksum and update the signature EEPROM word.	15ms if EEPROM signature is updated; 10µs otherwise
A0 <sub>HEX</sub>	0000 <sub>HEX</sub>	Start_CM => Start Command Mode; used to enter Command Mode. Start_CM is only valid during the power-on command window.	10µs

†† All time values shown are typical; for worst case values, multiply by 1.15 (nominal frequency ±15%).

In Command Mode, the INT/SS pin operates as an interrupt by rising when a command has finished executing. With this form of positive acknowledgement, the master does not need to poll the ZSC31014 to determine if the command was received and completed. This is particularly useful for commands that take the ZSC31014 longer to complete, such as EEPROM programming. If needed, a response byte of 5A<sub>HEX</sub> can be fetched after a command has been executed. In the case of an EEPROM read, this byte is included as the first byte of the data fetch.

### 3.6. EEPROM Bits

Table 3.7 provides a summary of the EEPROM contents, which determine ZSC31014 operation, including communication, and store the calibration coefficients and the customer ID. The ZSC31014 EEPROM contains twenty 16-bit words. See section 3.4.2 for instructions for writing to the EEPROM in Command Mode via the I<sup>2</sup>C™ interface.

**Table 3.7 EEPROM Word/Bit Assignments**

Note: IC default setting bits with the designation “s” indicate that the bit is set at the factory to a value determined at final test/programming.

EEPROM Word	Bit Range	IC Default	Description	Note
00 <sub>HEX</sub>	7:0	s s s s s s s s <sub>BIN</sub> X coordinate on wafer test	Cust_ID0	Customer ID word 0 (combines with EEPROM words 0E <sub>HEX</sub> and 13 <sub>HEX</sub> to form the customer ID). Programmed with the X coordinate on wafer test, the wafer number, and the 3 LSBs of lot number as the default values.
	12:8	s s s s s s s s <sub>BIN</sub> Wafer number		
	15:13	s s s <sub>BIN</sub> 3 LSBs of lot number		

EEPROM Word	Bit Range	IC Default	Description	Note										
01 <sub>HEX</sub>	ZMDI_Config_1			Bits in the ZMDI_Config_1 EEPROM word control the following settings. <i>Important:</i> IC must be power-cycled after changes to this word.										
	2:0	001 <sub>BIN</sub>	IDT Reserved	Must preserve factory settings.										
	3	1 <sub>BIN</sub>	ClkSpeed	Digital Core Clock Frequency 0 = 4MHz 1 = 1MHz										
	4	0 <sub>BIN</sub>	Comm_Type	Serial Communication Type 0 = I <sup>2</sup> C™ 1 = SPI										
	5	0 <sub>BIN</sub>	Sleep_Mode	Normal Operation Mode 0 = Update Mode 1 = Sleep Mode										
	7:6	01 <sub>BIN</sub>	Update_Rate	The following time values are typical; for worst case values, multiply by 1.15 (nominal frequency ±15%).  <table border="0"> <tr> <td>1MHz Clock</td> <td>4MHz Clock</td> </tr> <tr> <td>00 = 1.6ms</td> <td>00 = 0.5ms</td> </tr> <tr> <td>01 = 5.0ms</td> <td>01 = 1.5ms</td> </tr> <tr> <td>10 = 25.0ms</td> <td>10 = 6.5ms</td> </tr> <tr> <td>11 = 125.0ms</td> <td>11 = 32.0ms</td> </tr> </table>	1MHz Clock	4MHz Clock	00 = 1.6ms	00 = 0.5ms	01 = 5.0ms	01 = 1.5ms	10 = 25.0ms	10 = 6.5ms	11 = 125.0ms	11 = 32.0ms
	1MHz Clock	4MHz Clock												
	00 = 1.6ms	00 = 0.5ms												
	01 = 5.0ms	01 = 1.5ms												
	10 = 25.0ms	10 = 6.5ms												
11 = 125.0ms	11 = 32.0ms													
8	0 <sub>BIN</sub>	IDT Reserved	Must preserve factory settings.											
9	0 <sub>BIN</sub>	SOT_curve	Type of second-order curve correction on bridge. If set to 0, the bridge SOT will correct for a parabolic curve. If set to 1, the bridge SOT will correct for an S-shaped curve.											
11:10	00 <sub>BIN</sub>	TC_Sign	TC_Sign[0] = 1, Tco is a negative number. TC_Sign[1] = 1, Tcg is a negative number.											
15:12	s000 <sub>BIN</sub>	SOT_Sign	SOT_Sign[0] = 1, SOT_bridge is negative. SOT_Sign[1] = 1, SOT_tco is negative. SOT_Sign[2] = 1, SOT_tcg is negative. SOT_Sign[3] = 1, SOT_T is negative. <sup>##</sup>											

<sup>##</sup> For this register, **s** = IDT factory calibration data required for on-chip temperature-sensor data accuracy of ≤ ±2.5K; if the user is recalibrating over temperature, including the on-chip temperature sensor, set bit 15 in 01<sub>HEX</sub> (SOT\_Sign[3]) to the default value 0<sub>BIN</sub> (default data: register 01<sub>HEX</sub> = 0049<sub>HEX</sub>).

EEPROM Word	Bit Range	IC Default	Description	Note
02 <sub>HEX</sub>	ZMDI_Config_2			Bits in the ZMDI_Config_2 EEPROM word control the following settings. <i>Important:</i> IC must be power-cycled after changes to this word.
	0	0 <sub>BIN</sub>	SPI_Polarity	Configure clock polarity of SPI interface 0 = MISO changes on SCLK negative edge. 1 = MISO changes on SCLK positive edge.
	2:1	00 <sub>BIN</sub>	Diag_cfg	2-bit diagnostic configuration field. Diag_cfg[0] enables sensor connection check. Diag_cfg[1] enables sensor short checking.
	9:3	0101000 <sub>BIN</sub>	Slave_Addr	I <sup>2</sup> C™ slave address (default = 28 <sub>HEX</sub> ). Valid range is 00 <sub>HEX</sub> to 7F <sub>HEX</sub> .
	12:10	000 <sub>BIN</sub>	Comm_lock	Communications address lock <sup>§§</sup> 011 => locked All other => unlocked When communication is locked, I <sup>2</sup> C™ communication will only respond to its programmed address. Otherwise if communication is unlocked, I <sup>2</sup> C™ will respond to any address.
03 <sub>HEX</sub>	15:13	000 <sub>BIN</sub>	EEP_Lock	EEPROM lock 011 = locked All other = unlocked When EEPROM is locked, the internal charge pump is disabled and the EEPROM can never be programmed again. <b>NOTE:</b> Next command must be Start_NOM so that the signature is calculated and written to EEPROM before power down.***
	15:0	0000 <sub>HEX</sub>	Offset_B	Signed 16-bit offset for bridge correction. See section 2.2.2 for details on programming Offset_B for raw data collection.
04 <sub>HEX</sub>	14:0	010 0000 0000 0000 <sub>BIN</sub>	Gain_B	15-bit magnitude of bridge gain. Always positive. Unity is 2000 <sub>HEX</sub> .
	15	0 <sub>BIN</sub>	Gain8x_B	Multiple Gain_B by 8 0 = Gain_B x 1 1 = Gain_B x 8

§§ The Comm\_lock was set to 011<sub>BIN</sub> during wafer test for parts manufactured before workweek (ww) 13/2009.

\*\*\* Caution: If the part is power-cycled instead, the lock will take effect, and the checksum will be permanently wrong. In this case, the part will always output a diagnostic state.

EEPROM Word	Bit Range	IC Default	Description	Note
05 <sub>HEX</sub>	15:0	0000 <sub>HEX</sub>	Tcg	Coefficient for temperature correction of bridge gain term. Tcg = 16-bit magnitude of Tcg term with sign determined by TC_Sign[1].
06 <sub>HEX</sub>	15:0	0000 <sub>HEX</sub>	Tco	Coefficient for temperature correction of bridge offset term. Tco = 16-bit magnitude of Tco term with sign determined by TC_Sign[0].
07 <sub>HEX</sub>	15:0	0000 <sub>HEX</sub>	SOT_tco	2 <sup>nd</sup> order term applied to Tco. This term is a 16-bit magnitude with sign determined by SOT_Sign[1].
08 <sub>HEX</sub>	15:0	0000 <sub>HEX</sub>	SOT_tcg	2 <sup>nd</sup> order term applied to Tcg. This term is a 16-bit magnitude with sign determined by SOT_Sign[2].
09 <sub>HEX</sub>	15:0	0000 <sub>HEX</sub>	SOT_bridge	2 <sup>nd</sup> order term applied to the bridge measurement. This term is a 16-bit magnitude with sign determined by SOT_Sign[0]. SOT_curve selects parabolic or S-shaped fit.
0A <sub>HEX</sub>	15:0	ssss <sub>HEX</sub>	Offset_T	Temperature offset correction coefficient. <sup>†††</sup>
0B <sub>HEX</sub>	14:0	sss ssss ssss ssss <sub>BIN</sub>	Gain_T	Temperature gain correction coefficient. <sup>†††</sup>
	15	s <sub>BIN</sub>	Gain8x_T	Multiple Gain_T by 8 <sup>†††</sup> 0 = Gain_T x 1 1 = Gain_T x 8
0C <sub>HEX</sub>	15:0	ssss <sub>HEX</sub>	SOT_T	2 <sup>nd</sup> order term applied to the temperature reading. This term is a 16-bit magnitude with sign determined by SOT_Sign[3]. Always a parabolic fit. <sup>†††</sup>
0D <sub>HEX</sub>	15:0	ssss <sub>HEX</sub>	T <sub>SETL</sub>	Stores raw temperature reading at the temperature at which low calibration points were taken. <sup>†††</sup>
0E <sub>HEX</sub>	15:0	00ss <sub>HEX</sub> Has been set to Y coordinate (ss) at the factory.	Cust_ID1	Customer ID word 1 (combines with EEPROM words 00 <sub>HEX</sub> and 13 <sub>HEX</sub> to form the customer ID). Programmed with the Y coordinate of wafer location (ss) as the default. <b>Important:</b> Record the value of ss before overwriting with the user's Customer ID word in case the value is needed for customer support.

<sup>†††</sup> For these registers, s = IDT factory calibration data required for on-chip temperature-sensor data accuracy of  $\leq \pm 2.5K$ ; if the user is re-calibrating over temperature, including the on-chip temperature sensor, set these registers to the following default settings: register 0A<sub>HEX</sub> = 0000<sub>HEX</sub>; register 0B<sub>HEX</sub> = 2000<sub>HEX</sub>; register 0C<sub>HEX</sub> = 0000<sub>HEX</sub>; register 0D<sub>HEX</sub> = 0000<sub>HEX</sub>.

EEPROM Word	Bit Range	IC Default	Description	Note																												
0F <sub>HEX</sub>	B_Config Register			Front-end configuration for bridge measurement																												
	3:0	1000 <sub>BIN</sub>	A2D_Offset [3:0]	<table border="1"> <thead> <tr> <th>[3:0]</th> <th>A2D Range</th> <th>[3:0]</th> <th>A2D Range</th> </tr> </thead> <tbody> <tr> <td>1010</td> <td>5/8 to 3/8</td> <td>0100</td> <td>-1/4 to 3/4</td> </tr> <tr> <td>1001</td> <td>-9/16 to 7/16</td> <td>0011</td> <td>-3/16 to 13/16</td> </tr> <tr> <td>1000</td> <td>-1/2 to 1/2</td> <td>0010</td> <td>-1/8 to 7/8</td> </tr> <tr> <td>0111</td> <td>-7/16 to 9/16</td> <td>0001</td> <td>-1/16 to 15/16</td> </tr> <tr> <td>0110</td> <td>-3/8 to 5/8</td> <td>0000</td> <td>0 to 16/16</td> </tr> <tr> <td>0101</td> <td>-5/16 to 11/16</td> <td colspan="2">See Table 2.4 for more details.</td> </tr> </tbody> </table>	[3:0]	A2D Range	[3:0]	A2D Range	1010	5/8 to 3/8	0100	-1/4 to 3/4	1001	-9/16 to 7/16	0011	-3/16 to 13/16	1000	-1/2 to 1/2	0010	-1/8 to 7/8	0111	-7/16 to 9/16	0001	-1/16 to 15/16	0110	-3/8 to 5/8	0000	0 to 16/16	0101	-5/16 to 11/16	See Table 2.4 for more details.	
	[3:0]	A2D Range	[3:0]	A2D Range																												
	1010	5/8 to 3/8	0100	-1/4 to 3/4																												
	1001	-9/16 to 7/16	0011	-3/16 to 13/16																												
	1000	-1/2 to 1/2	0010	-1/8 to 7/8																												
	0111	-7/16 to 9/16	0001	-1/16 to 15/16																												
	0110	-3/8 to 5/8	0000	0 to 16/16																												
	0101	-5/16 to 11/16	See Table 2.4 for more details.																													
6:4	010 <sub>BIN</sub>	PreAmp_Gain [2:0]	<table border="1"> <thead> <tr> <th>[2:0] PreAmp_Gain</th> <th>GAIN</th> </tr> </thead> <tbody> <tr> <td>000</td> <td>1.5</td> </tr> <tr> <td>100</td> <td>3</td> </tr> <tr> <td>001</td> <td>6</td> </tr> <tr> <td>101</td> <td>12</td> </tr> <tr> <td>010</td> <td>24</td> </tr> <tr> <td>110</td> <td>48</td> </tr> <tr> <td>011</td> <td>96</td> </tr> <tr> <td>111</td> <td>192</td> </tr> </tbody> </table>	[2:0] PreAmp_Gain	GAIN	000	1.5	100	3	001	6	101	12	010	24	110	48	011	96	111	192											
[2:0] PreAmp_Gain	GAIN																															
000	1.5																															
100	3																															
001	6																															
101	12																															
010	24																															
110	48																															
011	96																															
111	192																															
7	1 <sub>BIN</sub>	Gain_Polarity	Gain polarity: 0=negative gain, 1=positive gain																													
8	1 <sub>BIN</sub>	LongInt	If 1, selects long integration period (11-coarse + 3 fine), which results in lower noise, slower conversion; If 0, the conversion is done as (9 coarse + 5 fine).																													
9	1 <sub>BIN</sub>	Bsink	If 1, Bsink pull-down will be enabled during the measurement.																													
11:10	10 <sub>BIN</sub>	PreAmp_Mux [1:0]	<table border="1"> <thead> <tr> <th>PreAmp_Mux [1:0]</th> <th>Measurement</th> </tr> </thead> <tbody> <tr> <td>10</td> <td>Bridge</td> </tr> <tr> <td>11</td> <td>Half-bridge input</td> </tr> </tbody> </table>	PreAmp_Mux [1:0]	Measurement	10	Bridge	11	Half-bridge input																							
PreAmp_Mux [1:0]	Measurement																															
10	Bridge																															
11	Half-bridge input																															
12	0 <sub>BIN</sub> (must be 0 if using a PreAmp Gain ≥ 6)	Disable_Nulling	Disable Nulling 0 = Nulling On 1 = Nulling Off (Use this setting if PreAmp gain <6.)																													
15:13	000 <sub>BIN</sub>	IDT Reserved	Must preserve factory settings.																													

EEPROM Word	Bit Range	IC Default	Description	Note																												
10 <sub>HEX</sub>	T_Config Register			Front-end configuration for temperature measurement																												
	3:0	SSSS <sub>BIN</sub>	A2D_Offset [3:0]	<p><b>DO NOT CHANGE</b> default setting. Trimmed at production test to avoid saturation.</p> <table border="1"> <thead> <tr> <th>[3:0]</th> <th>A2D Range</th> <th>[3:0]</th> <th>A2D Range</th> </tr> </thead> <tbody> <tr> <td>1010</td> <td>5/8 to 3/8</td> <td>0100</td> <td>-1/4 to 3/4</td> </tr> <tr> <td>1001</td> <td>-9/16 to 7/16</td> <td>0011</td> <td>-3/16 to 13/16</td> </tr> <tr> <td>1000</td> <td>-1/2 to 1/2</td> <td>0010</td> <td>-1/8 to 7/8</td> </tr> <tr> <td>0111</td> <td>-7/16 to 9/16</td> <td>0001</td> <td>-1/16 to 15/16</td> </tr> <tr> <td>0110</td> <td>-3/8 to 5/8</td> <td>0000</td> <td>0 to 16/16</td> </tr> <tr> <td>0101</td> <td>-5/16 to 11/16</td> <td></td> <td>See Table 2.4 for more details.</td> </tr> </tbody> </table>	[3:0]	A2D Range	[3:0]	A2D Range	1010	5/8 to 3/8	0100	-1/4 to 3/4	1001	-9/16 to 7/16	0011	-3/16 to 13/16	1000	-1/2 to 1/2	0010	-1/8 to 7/8	0111	-7/16 to 9/16	0001	-1/16 to 15/16	0110	-3/8 to 5/8	0000	0 to 16/16	0101	-5/16 to 11/16		See Table 2.4 for more details.
	[3:0]	A2D Range	[3:0]	A2D Range																												
	1010	5/8 to 3/8	0100	-1/4 to 3/4																												
	1001	-9/16 to 7/16	0011	-3/16 to 13/16																												
	1000	-1/2 to 1/2	0010	-1/8 to 7/8																												
	0111	-7/16 to 9/16	0001	-1/16 to 15/16																												
	0110	-3/8 to 5/8	0000	0 to 16/16																												
	0101	-5/16 to 11/16		See Table 2.4 for more details.																												
6:4	001 <sub>BIN</sub>	PreAmp_Gain[2:0]	<p><b>DO NOT CHANGE</b> default setting. Temperature measurement requires a gain of 6 to avoid saturation.</p> <table border="1"> <thead> <tr> <th>[6:4]</th> <th>Gain</th> <th>[6:4]</th> <th>Gain</th> </tr> </thead> <tbody> <tr> <td>000</td> <td>1.5</td> <td>010</td> <td>24</td> </tr> <tr> <td>100</td> <td>3</td> <td>110</td> <td>48</td> </tr> <tr> <td>001</td> <td>6</td> <td>011</td> <td>96</td> </tr> <tr> <td>101</td> <td>12</td> <td>111</td> <td>192</td> </tr> </tbody> </table>	[6:4]	Gain	[6:4]	Gain	000	1.5	010	24	100	3	110	48	001	6	011	96	101	12	111	192									
[6:4]	Gain	[6:4]	Gain																													
000	1.5	010	24																													
100	3	110	48																													
001	6	011	96																													
101	12	111	192																													
7	1 <sub>BIN</sub>	Gain_Polarity	<p><b>DO NOT CHANGE</b> default setting. Gain_Polarity must be positive for internal temperature measurements.</p> <p>Gain polarity; 0 = negative, 1= positive gain.</p>																													
8	0 <sub>BIN</sub>	LongInt	If 1, selects long integration period (11-coarse + 3 fine), for lower noise, slower conversion; otherwise, the conversion is (9 coarse + 5 fine).																													
9	0 <sub>BIN</sub>	Bsink	<b>DO NOT CHANGE</b> default setting. Bsink must be disabled for internal temperature measurements.																													
11:10	01 <sub>BIN</sub>	PreAmp_Mux [1:0]	<b>DO NOT CHANGE</b> default setting.																													
12	0 <sub>BIN</sub>	Disable_Nulling	<b>DO NOT CHANGE</b> default setting. Nulling is enabled for temperature measurements																													
15:13	000 <sub>BIN</sub>	IDT Reserved	<b>DO NOT CHANGE</b> default setting. Must preserve factory settings.																													
11 <sub>HEX</sub>	7:0	0011 SSSS <sub>BIN</sub>	Osc_Trim	<b>DO NOT CHANGE</b> default setting. Must preserve factory settings.																												
	15:8		Unused																													

EEPROM Word	Bit Range	IC Default	Description	Note
12 <sub>HEX</sub>	15:0	-	Signature	Generated through a linear feedback shift register (LFSR). After EEPROM changes, the next command that is sent must be Start_NOM so that the signature is calculated and written to EEPROM. Signature checked on power-up to ensure EEPROM contents integrity.
13 <sub>HEX</sub>	15:0	MSB of lot number	Cust_ID2	Customer ID word 2 (combines with EEPROM words 00 <sub>HEX</sub> and 0E <sub>HEX</sub> to form customer ID). Programmed with the MSB of the lot number as the default.

### 3.7. Calibration Sequence

Although the ZSC31014 can work with many different sources of differential signals, assume a pressure bridge for the following discussion on calibration.

Calibration essentially involves collecting raw signal and temperature data from the device for different known pressures and temperatures. This raw data can then be processed by the calibration master (assumed to be a PC), and the calculated calibration coefficients can then be written to EEPROM.

IDT can provide software and hardware with samples to perform the calibration. Below is a brief overview of the steps involved in calibrating a ZSC31014. See *ZSC31014\_SSC\_Evaluation\_Kit\_Description\_Rev\_X.xy.pdf* for a complete description and detailed examples.

For SOP8-packaged parts, the on-chip temperature sensor is calibrated by IDT production test with an error  $\leq 2.5K$  over the full operational temperature range of  $-40^{\circ}C$  to  $+125^{\circ}C$ . The resulting IC-specific correction coefficients required for the signal conditioning of the temperature output data are stored in the EEPROM registers 0A<sub>HEX</sub> to 0D<sub>HEX</sub> and must remain unchanged if these temperature signal conditioning coefficients are used without re-calibration over temperature. If instead the SOP8 parts are recalibrated, EEPROM registers 0A<sub>HEX</sub> to 0D<sub>HEX</sub> must be changed to the same default values as for the die prior to calibration (see Table 3.7).

There are three main steps to calibration:

1. Assigning a unique identification to the IC. This identification is programmed in EEPROM and can be used as an index into a database stored on the calibration PC. This database will contain all the raw values of bridge readings and temperature readings for that part, as well as the known pressure and temperature the bridge was exposed to. This unique identification can be stored in the three 16-bit EEPROM registers dedicated to customer ID.
2. Data collection. Data collection involves getting uncorrected data from the bridge at different known pressures and temperatures. This data is then stored on the calibration PC using the unique identification of the device as the index to the database.
3. Coefficient calculation and storage in EEPROM. After enough data points have been collected to calculate all the desired coefficients, then the coefficients can be calculated by the calibrating PC and written to the EEPROM of the device.

### Step 1 – Assigning Unique Identification

Assigning a unique identification number is as simple as using the EEPROM WRITE command (see section 3.5) to write the identification number to Cust\_ID0 (EEPROM word 00<sub>HEX</sub>), Cust\_ID1 (EEPROM word 0E<sub>HEX</sub>), and Cust\_ID2 (EEPROM word 13<sub>HEX</sub>); see section 3.6). These three 16-bit registers allow for more than 280 trillion unique devices.

**Important:** Record the value of the Y coordinate for the die's wafer location, which is stored as the default value in bits [7:0] in register 0E<sub>HEX</sub> (see definition of *ss* on page 41), before overwriting with the user's Customer ID word 1 in case the value is needed for customer support.

### Step 2 – Data Collection

The number of unique points (pressure and/ or temperature) at which calibration must be performed depends on the requirements of the application and the behavior of the resistive bridge in use. The minimum number of points required is equal to the number of bridge coefficients to be corrected. The available calibration methods and the required number of points for each are listed below:

1. 2-point calibration can be used if only a gain and offset term are needed for a bridge with no temperature compensation for either term.
2. 3-point calibration would be used to obtain 1<sup>st</sup> order compensation for either a Tco or Tcg term but not both.
3. 3-point calibration could also be used to obtain 2<sup>nd</sup> order correction for the bridge (SOT\_bridge) but no temperature compensation of the bridge output.
4. 4-point calibration would be used to obtain 1<sup>st</sup> order compensation for both Tco and Tcg.
5. 4-point calibration could also be used to obtain 1<sup>st</sup> order compensation for either Tco or Tcg (but not both) and a 2<sup>nd</sup> order correction for the bridge measurement.
6. 5-point calibration could be used to obtain both 1<sup>st</sup> order Tco correction and 1<sup>st</sup> order Tcg correction, plus a 2<sup>nd</sup> order correction that could be applied to one and only one of the following: 2<sup>nd</sup> order Tco (SOT\_tco); 2<sup>nd</sup> order Tcg (SOT\_tcg); or 2<sup>nd</sup> order bridge.
7. There are many options for a 6-point calibration; however, the most likely would be for both 1<sup>st</sup> and 2<sup>nd</sup> order correction of Tco and Tcg.
8. 7-point calibration would have all three 2<sup>nd</sup> order terms applied: SOT\_tco, SOT\_tcg, and SOT\_bridge.

### Step 3 – Coefficient Calculations

The math to perform the coefficient calculation is complicated and will not be discussed in detail. There is a rough overview in section 3.8. IDT provides software (DLLs) to perform the coefficient calculation. After the coefficients are calculated, the final step is to write them to the EEPROM of the ZSC31014.

## 3.8. Calibration Math

IDT can provide software and hardware with samples to perform the calibration. For a complete description and detailed examples, see *ZSC31014\_SSC\_Evaluation\_Kit\_Description\_Rev\_X.xy.pdf*. For more details on the following equations, refer to *ZSC31014 Technical Note—Detailed Equations for ZSC31014 Math* (available on request).

### 3.8.1. Bridge Signal Compensation

SOT\_curve (bit 9 in EEPROM word 01<sub>HEX</sub>; see section 3.6) selects whether second-order equations compensate for sensor nonlinearity with a parabolic or S-shaped curve.

The correction formula for the differential signal reading is represented as a two-step process depending on the SOT\_curve setting.

**Note:** The following equations are only meant to show the general form and capabilities of the ZSC31014 sensor signal conditioning. Full details of the equations are not given.

Equations for the parabolic SOT\_curve setting (SOT\_curve = 0):

$$\mathbf{ZB} = \mathbf{Gain\_B} [1 + \Delta\mathbf{T}(\mathbf{SOT\_tcg} * \Delta\mathbf{T} + \mathbf{Tcg})] * [\mathbf{BR\_Raw} + \mathbf{Offset\_B} - \mathbf{ADC\_Offset} + \Delta\mathbf{T}(\mathbf{SOT\_tco} * \Delta\mathbf{T} + \mathbf{Tco})] + 2000_{\mathbf{HEX}} \quad (4)$$

$$\mathbf{B} = \mathbf{ZB} * (1 + \mathbf{SOT\_bridge} * \mathbf{ZB}) \quad (5)$$

Equations for the S-shaped SOT\_curve setting (SOT\_curve = 1):

$$\mathbf{ZB} = \mathbf{Gain\_B} [1 + \Delta\mathbf{T}(\mathbf{SOT\_tcg} * \Delta\mathbf{T} + \mathbf{Tcg})] * [\mathbf{BR\_Raw} + \mathbf{Offset\_B} - \mathbf{ADC\_Offset} + \Delta\mathbf{T}(\mathbf{SOT\_tco} * \Delta\mathbf{T} + \mathbf{Tco})] \quad (6)$$

$$\mathbf{B} = \mathbf{ZB} * (1 + \mathbf{SOT\_bridge} * |\mathbf{ZB}|) + 2000_{\mathbf{HEX}} \quad (7)$$

Where

- B** = Corrected bridge reading output via I<sup>2</sup>C™ or SPI
- ZB** = Intermediate result in the calculations
- BR\_Raw** = Raw bridge reading from ADC after AZ correction
- Gain\_B** = Bridge gain term
- Offset\_B** = Bridge offset term
- Tcg** = Temperature coefficient gain term
- Tco** = Temperature coefficient offset term
- T\_Raw** = Raw temperature reading
- T<sub>SETL</sub>** = T\_Raw reading at which low calibration was performed (typically 25°C)
- ΔT** = (T\_Raw - T<sub>SETL</sub>)
- SOT\_tcg** = Second-order term for Tcg non-linearity
- SOT\_tco** = Second-order term for Tco non-linearity
- SOT\_bridge** = Second-order term for bridge non-linearity
- 2000<sub>HEX</sub>** = Converts result to the unsigned domain
- ADC\_Offset** = 2<sup>14</sup> \* ratio of the selected A2D\_Offset (EEPROM word B\_Config)

### 3.8.2. Temperature Signal Compensation

If a compensated temperature output is also required, a temperature calibration is necessary. Temperature correction contains both linear gain and offset terms as well as a second-order term to correct for any non-linearities. For temperature, second-order compensation for nonlinearity is always parabolic.

The following equations are only meant to show the general form and capabilities of the ZSC31014 sensor signal conditioning. Full details of the equations are not given.

Again, the correction formula is best represented as a two-step process as follows:

$$ZT = \text{Gain\_T} * [T\_Raw + \text{Offset\_T}] \tag{8}$$

$$T = ZT * (1 + \text{SOT\_T} * ZT) \tag{9}$$

Where:

- Gain\_T** = Gain coefficient for temperature
- T\_Raw** = Raw temperature reading
- Offset\_T** = Offset coefficient for temperature
- SOT\_T** = Second-order term for temperature source non-linearity

### 3.8.3. Limits Imposed on Coefficient Ranges

There are range limits on some of the calibration coefficients that will be enforced by software and DLLs provided by IDT. These limits ensure the integrity of the internal calculations and would only limit the most extreme cases of sensor correction. The limits are outlined in Table 3.8.

**Table 3.8 Restrictions on Coefficient Ranges**

Coefficient	Valid Range	Comment
Gain_B, Gain_T	When Gain8x=0: 2000 to 7FFF When Gain8x=1: 400 to 7FFF	A gain less than unity (attenuating) implies the range of interest is being clipped in the A2D. In this case, a lower PreAmp_Gain should be chosen. Gains greater than 7FFF (≈4.0) can cause overflow in the internal calculations. If digital gains greater than 4.0 are needed for the bridge, use the Gain8x feature.
Offset_B, Offset_T	Positive offset (0 to 1FFF) Negative offset (E000 to FFFF)	Offsets are a signed number that is added to the result of a 14-bit A2D conversion. Although the EEPROM register is 16-bits wide, the coefficient cannot exceed the range of a signed 14-bit number.
SOT_B, SOT_T	Positive SOT (0 to 7FFF) Negative SOT (0 to 3FF)	Positive SOTs greater than 7FFF can cause overflow in the internal math. Negative SOTs greater in magnitude than 3FF are invalid because the function becomes double definite.

### 3.8.4. Interpretation of Binary Numbers for Correction Coefficients

**BR\_Raw** should be interpreted as a signed number in the set [-8192,8191] with a resolution of 1 when the Offset Mode is [-1/2,1/2].

**T\_Raw** should be interpreted as an unsigned number in the set [0,16383] with a resolution of 1.

#### 3.8.4.1. Gain\_B and Gain\_T Interpretation

Gain\_B and Gain\_T should be interpreted as a number in the set [0,4). 2000<sub>HEX</sub> represents unity. Bit 14 has a weight of 2, and each subsequent bit has a weighting of ½ the previous bit. Bit 15 scales Gain\_B or Gain\_T by an additional factor of 8. This allows Gain\_B or Gain\_T to be a number in the range [0,32).

**Table 3.9 Gain\_B Weightings**

Bit Position	Weighting
15	Gain8x
14	2
13	1
12	2 <sup>-1</sup>
...	
1	2 <sup>-12</sup>
0	2 <sup>-13</sup>

Examples:

The binary number: 0100 1010 0110 0010 = 2.3245

The binary number: 1101 1000 1001 0110 = 22.146

#### 3.8.4.2. Offset\_B and Offset\_T Interpretation

Offset\_B and Offset\_T are 16-bit signed binary numbers in two's complement form. The MSB has a weighting of -32768. The following bits then have a weighting of: 16384, 8192, 4096 ...

**Table 3.10 Offset\_B Weightings**

Bit Position	Weighting
15	-32768
14	16384
13	8192
...	
1	2 <sup>1</sup> = 2
0	2 <sup>0</sup> = 1

For example, the binary number 1111 1111 1111 1100 = -4.

**3.8.4.3. Tco Interpretation**

Tco is specified as having a 16-bit magnitude with its sign determined by TC\_Sign (bits [11:10] of EEPROM word 01<sub>HEX</sub>; see section 3.6).

**3.8.4.4. Tcg Interpretation**

Tcg is specified as having a 16-bit magnitude with its sign determined by TC\_Sign (bits [11:10] of EEPROM word 01<sub>HEX</sub>; see section 3.6).

**3.8.4.5. SOT\_tco, SOT\_tcg, SOT\_bridge, and SOT\_T Interpretation**

All SOT\_terms are specified as having a 16-bit magnitude with the sign determined by SOT\_Sign (bits [15:12] of EEPROM word 01<sub>HEX</sub>; see section 3.6).

SOT\_curve selects parabolic or S-shaped fit for the bridge compensation. For temperature compensation, parabolic is always used.

## 4 Application Circuit Examples

The digital output of the ZSC31014 can be read via I<sup>2</sup>C™ or SPI. The ZSC31014 can be configured in Sleep or Update Mode for the Normal Operation Mode, which outputs the corrected measurement readings. The B\_Config settings for Gain\_Polarity, PreAmp\_Gain and A2D\_Offset are given only as examples because these values must be adapted specifically to the sensor signal range.

### 4.1. I<sup>2</sup>C™ Interface – Bridge using Low Power Bsink Option

This example demonstrates the low power Bsink option with internal temperature sensing. Data is output via the I<sup>2</sup>C™ interface. For this application, V<sub>DD</sub> is assumed to be 5V and the bridge sensor voltage is 16.5mV to 61.5mV. In this case, the B\_Config register setting for PreAmp\_Gain is 24, which means nulling should be on, and the A2D\_Offset is ½ to - ½. Update Mode with a slower update rate and Bsink are enabled to save power.

For temperature correction, use the T\_Config settings that are pre-programmed in production test. (See the T\_Config defaults in Table 3.7.)

**NOTE:** The A2D\_Offset and PreAmp\_Gain terms in T\_Config are programmed during test to avoid saturation of the internal temperature bridge. Do not change these parameters (designated with † in Table 4.1).

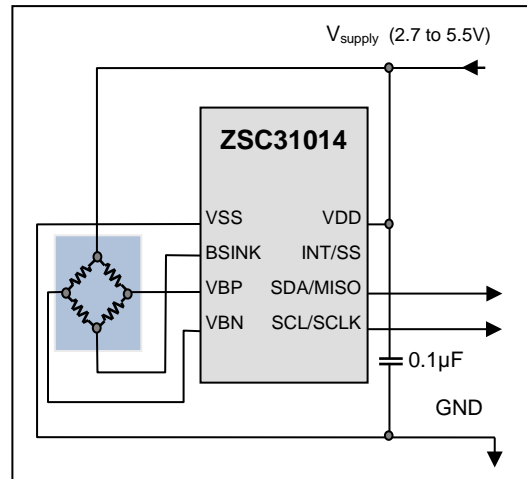

**Figure 4.1** Example 1 Circuit Diagram: Bsink Option and Internal Temperature Correction and I<sup>2</sup>C™ Output

**Table 4.1** Register Settings—Example 1

	Reserved [15:13]			Disable Nulling [12]	PreAmp_Mux [11:10]		Bsink[9]	LongInt[8]	Gain_Polarity[7]	PreAmp_Gain [6:4]			A2D_Offset [3:0]			
B_Config 0F <sub>HEX</sub>	0	0	0	0	1	0	1	0	1	0	1	0	1	0	0	0
T_Config 10 <sub>HEX</sub>	0	0	0	0	0	1	0 <sup>†</sup>	0	1	0 <sup>†</sup>	0 <sup>†</sup>	1 <sup>†</sup>	†	†	†	†

† Reserved setting – do not change factory settings. If factory trim settings have been lost, program T\_Config to 149<sub>HEX</sub>.

### 4.2. Generic Differential A2D Converter

The ZSC31014 has many PreAmp\_Gain settings available and makes an excellent 14-bit analog-to-digital converter with I<sup>2</sup>C™ or SPI output for any differential signal source. In this application, the ZSC31014 is being used as a generic differential A2D converter. The PreAmp\_Mux bit in B\_Config must be set to 10. The PreAmp\_Gain is set to 24, which means nulling should be on, and the A2D\_Offset is set to -1/2, 1/2 in this example.

For temperature correction, use the T\_Config settings that are pre-programmed in production test. (See the T\_Config defaults in Table 3.7.)

**NOTE:** The A2D\_Offset and PreAmp\_Gain terms in T\_Config are programmed during test to avoid saturation of the internal temperature bridge. Do not change these parameters (designated with † in Table 4.2).

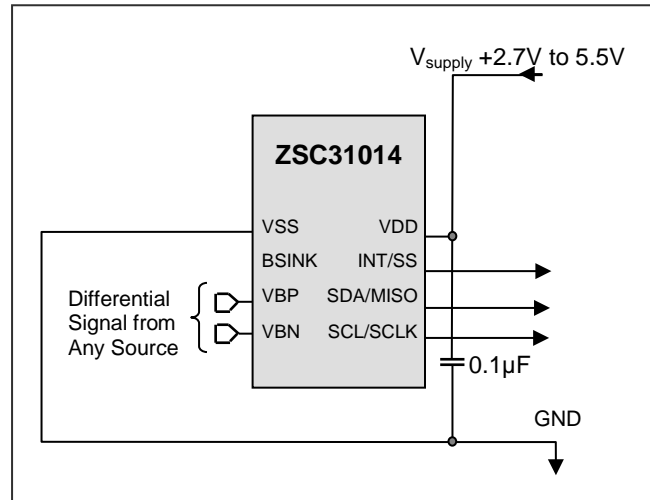

**Figure 4.2** Example 2 Circuit Diagram: Generic Differential A2D Converter

**Table 4.2** Register Settings—Example 2

	Reserved [15:13]				Disable Nulling [12]	PreAmp_Mux [11:10]		Bsink[9]	Longint[8]	Gain_Polarity[7]	PreAmp_Gain[6:4]			A2D_Offset [3:0]			
B_Config 0F <sub>HEX</sub>	0	0	0	0	0	1	0	0	0	1	0	1	0	1	0	0	0
T_Config 10 <sub>HEX</sub>	0	0	0	0	0	0	1	0 <sup>†</sup>	0	1	0 <sup>†</sup>	0 <sup>†</sup>	1 <sup>†</sup>	†	†	†	†

† Reserved setting – do not change factory settings. If factory trim settings have been lost, program T\_Config to 149<sub>HEX</sub>.

### 4.3. Half-Bridge Measurement

In this application, the ZSC31014 is being used as a signal conditioner for a half-bridge signal from a Honeywell HIH4000 humidity sensor. This application shows the option of measuring a single voltage (1V to 3.8V) and using the internal temperature sensor for temperature correction.

VBN is internally connected to a voltage divider as a reference ( $V_{DD}/2$ ). In this case, the PreAmp\_Mux bit in B\_Config must be 11 and the PreAmp\_Gain must be set to the lowest value (1.5), which means nulling should be off.

For temperature correction, use the T\_Config settings that are pre-programmed in production test. (See the T\_Config defaults in Table 3.7.)

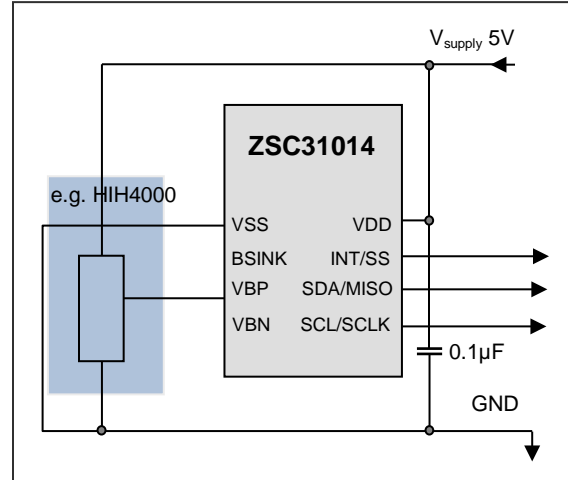

**Figure 4.3** Half-Bridge Voltage Measurement with Internal Temperature Correction

**NOTE:** The A2D\_Offset and PreAmp\_Gain terms in T\_Config are programmed during test to avoid saturation of the internal temperature bridge. Do not change these parameters (designated with † in Table 4.3).

**Table 4.3** Register Settings—Example 3

	Reserved [15:13]			Disable Nulling [12]	PreAmp_Mux [11:10]		Bsink[9]	Longint[8]	Gain_Polarity[7]	PreAmp_Gain[6:4]			A2D_Offset [3:0]			
B_Config 0F <sub>HEX</sub>	0	0	0	1	1	1	0	0	1	0	0	0	0	0	1	0
T_Config 10 <sub>HEX</sub>	0	0	0	0	0	1	0 <sup>†</sup>	0	1	0 <sup>†</sup>	0 <sup>†</sup>	1 <sup>†</sup>	†	†	†	†

† Reserved setting – do not change factory settings. If factory trim settings have been lost, program T\_Config to 149<sub>HEX</sub>.

## 5 ESD/Latch-Up-Protection

All pins have an ESD protection of >4000V and a latch-up protection of  $\pm 100\text{mA}$  or (up to +8V / down to -4V) relative to VSS/VSSA. ESD protection referenced to the Human Body Model is tested with devices in SOP-8 packages during product qualification. The ESD test follows the Human Body Model with 1.5kOhm/100pF based on MIL 883, Method 3015.7.

## 6 Pin Configuration and Package

The standard package of the ZSC31014 is SOP-8 (3.81mm body (150mil) wide) with lead-pitch 1.27mm (50mil). See the notes in Table 6.2 regarding connection requirements.

**Table 6.1 Storage and Soldering Conditions for the SOP-8 Package**

Parameter	Symbol	Conditions	Min	Typ	Max	Unit
Maximum Storage Temperature	$T_{\text{max\_storage}}$	Less than 10hrs, before mounting			150	°C
Minimum Storage Temperature:	$T_{\text{min\_storage}}$	Store in original packing only	-50			°C
Maximum Dry-Bake Temperature	$T_{\text{drybake}}$	Less than 100 hrs total, before mounting			125	°C
Soldering Peak Temperature	$T_{\text{peak}}$	Less than 30s (IPC/JEDEC-STD-020 Standard)			260	°C

Figure 6.1 ZSC31014 Pin-Out Diagram

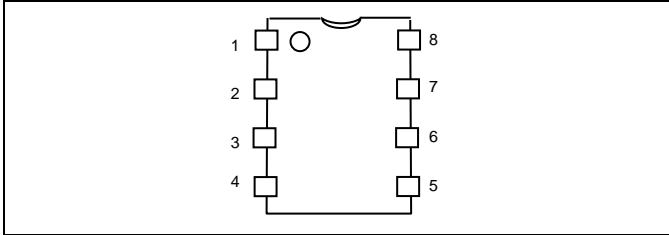

Table 6.2 ZSC31014 Pin Assignments

Pin No.	Name	Description	Note
1	VSS	Ground supply.	Must connect to GND.
2	Bsink	Switched ground for bridge sink – optional feature for power savings.	If not used, must be unconnected.
3	VBP	Positive input for differential signal (bridge positive).	
4	VBN	Negative input for differential signal (bridge negative).	
5	SCL/SCLK	I <sup>2</sup> C™ clock if in I <sup>2</sup> C™ Mode. Serial clock if in SPI Mode.	
6	SDA/MISO	I <sup>2</sup> C™ data if in I <sup>2</sup> C™ Mode. Master-In-Slave-Out if in SPI Mode.	
7	INT/SS	Interrupt signal (conversion complete output) if in I <sup>2</sup> C™ Mode. Slave Select (input) if in SPI Mode.	If not used, must be unconnected.
8	VDD	Supply voltage (2.7-5.5V).	Must connect to Vsupply.

## 7 Test

The test program is based on this datasheet. The final parameters, which will be tested during production, are listed in the tables of section 1.

The digital part of the IC includes a scan path, which can be activated and controlled during wafer test. It guarantees failure coverage of more than 80%. Additional digital and analog tests are added to increase this coverage to over 90%. See test specification for further details.

## 8 Reliability

A reliability investigation according to the in-house non-automotive standard has been performed.

## 9 Customization

For high-volume applications that require upgraded or downgraded functionality compared to the ZSC31014, IDT can customize the circuit design by adding or removing certain functional blocks. For this customization, IDT has a considerable library of sensor-dedicated circuitry blocks, which enable IDT to provide a custom solution quickly. Please contact IDT for further information.

## 10 Ordering Codes

Sales Code	Description	Package
ZSC31014EAB	ZSC31014 Die — Temperature range: -40°C to +125°C	Unsawn on Wafer
ZSC31014EAC	ZSC31014 Die — Temperature range: -40°C to +125°C	Sawn on Wafer Frame
ZSC31014EAG1	ZSC31014 SOP8 (150 mil) — Temperature range: -40° to +125°C	Tube: add “-T” to sales code Reel: add “-R”
ZSC31014EIB	ZSC31014 Die — Temperature range: -40° to +85°C	Unsawn on Wafer
ZSC31014EIC	ZSC31014 Die — Temperature range: -40° to +85°C	Sawn on Wafer Frame
ZSC31014EIG1	ZSC31014 SOP8 (150 mil) — Temperature range: -40° to +85°C	Tube: add “-T” to sales code Reel: add “-R”
ZSC31014KIT	ZSC31014 SSC Evaluation Kit: Communication Board, SSC Board, Sensor Replacement Board, USB Cable, and 5 IC Samples (software can downloaded on the ZSC31014 product page at <a href="http://www.IDT.com/ZSC31014">http://www.IDT.com/ZSC31014</a> )	

Contact IDT Sales for support and sales of IDT's ZSC31014 Mass Calibration System.

## 11 Related Documents

Document
ZSC31014 SSC Evaluation Kit Description
ZSC31014 SSC Mass Calibration System Description *
ZSC31014 Technical Notes—Calibration Sequence and Calibration DLL *
ZSC3xxx/ZSSC3xxx Application Note—Signal Conditioning for Single-Ended Input to Differential Inputs for Resistive Bridge Sensor Signal Conditioners*
ZSC31014 Application Note— $I^2C$ Network for RBiC <sub>ILite</sub> <sup>TM</sup> Sensor Modules *
ZSC31014 Application Note—Changing the RBiC <sub>ILite</sub> <sup>TM</sup> $I^2C$ Address
ZSC31014 Technical Note—Detailed Equations for Calibration Math **
IDT Technical Note—Wafer Dicing Guidelines

For the most recent revision of this document and of the related documents, visit the ZSC31014 product page at [www.IDT.com/ZSC31014](http://www.IDT.com/ZSC31014) or contact your nearest IDT sales office.

\* Documents marked with an asterisk (\*) require a login account for access on the web.

\*\* Documents marked with a double asterisk (\*\*) are available only on request.

## 12 Definitions of Acronyms

Term	Description
ADC	Analog-to-Digital Converter
AFE	Analog Front-End
ACK	Acknowledge
MCU	Microprocessor
MSB	Most Significant Bit
NACK	Not Acknowledged
SCL	Serial Clock
SDA	Serial Data
SPI	System Packet Interface

## 13 Document Revision History

Revision	Date	Description
1.20	May 15, 2009	Added notation for timing tolerance (nominal frequency $\pm 15\%$ ) in section 3. Table 2.4 A2D_Offset Signals. Added all possible configurations. Revised web address and sales contacts.
1.30	January 20, 2010	Revisions to EEPROM default values in Table 3.7. Addition of ordering information.
1.32	April 5, 2010	Clarification of ordering information. Correction of values in Table 1.4. Default values for Osc_trim changed. Changed Equations (4) and (6).
1.33	May 6, 2010	Added EEPROM specifications to section 1.3 "Electrical Parameters." Added Table 6.1 "Storage and Soldering Conditions" to section 6 "Pin Configuration and Package." Added notes to Table 6.2 "ZSC31014 Pin Assignments." Matched A2D_Offset settings in Table 3.7 for B_Config and T_Config to Table 2.4.
1.34	July 21, 2010	Clarification of external temperature measurement, section 2.2.3.2. Addition of DF4 to Figure 3.6.
1.40	July 27, 2010	Revision of product name from ZMD31014 to ZSC31014.
1.50	January 7, 2011	Added I <sup>2</sup> C™ specification deviation note, section 2.3.4
1.51	March 13, 2011	Update to ZMDI contact information.
1.52	July 12, 2011	Addition of Offset_B column to Table 2.4 for coefficient settings needed when collecting uncalibrated raw bridge values from the ADC.
1.53	May 10, 2012	Update to part ordering code table in section 10. Update to contact information. Revision of product title.
1.60	September 21, 2012	Revision of "Power-On-Reset Level" specification in section 1.3 and related text in section 2.3.6. Update for product ordering codes.
1.61	December 6, 2012	Update for contact information for Zentrum Mikroelektronik Dresden AG Korea Office and phone numbers for USA office.
1.62	March 11, 2013	Removed external temperature compensation. Updates for part order codes in section 10. Updates for contact information and minor edits to cover and header imagery.
1.63	April 21, 2014	Revision of "I <sup>2</sup> C™ Interface & SPI Interface" section of Table 1.3. Minor updates for references to product and contents of Evaluation Kit. Waffle pack is no longer an option for delivery package. Updates for contact information.
1.64	July 2, 2014	Revision of calibration temperature for SOP8-packaged parts in section 2.2.3 and related default entries for registers 0A <sub>HEX</sub> to 0D <sub>HEX</sub> in Table 3.7. Update for section 8 regarding quality testing. Updates for contact information.
1.65	November 2, 2015	Revision of calibration temperature for all delivery forms in section 2.2.3 and related default entries for registers 01 <sub>HEX</sub> and 0A <sub>HEX</sub> to 0D <sub>HEX</sub> in Table 3.7. Edit for default setting for bits [12:10] in register 02 <sub>HEX</sub> and related footnote. Added warnings to save Y location stored in default for bits [7:0] of register 0E <sub>HEX</sub> . Minor edits for clarity. Updates for related documents and for contact information.
	January 20, 2016	Changed to IDT branding.



## Notice

1. Descriptions of circuits, software and other related information in this document are provided only to illustrate the operation of semiconductor products and application examples. You are fully responsible for the incorporation or any other use of the circuits, software, and information in the design of your product or system. Renesas Electronics disclaims any and all liability for any losses and damages incurred by you or third parties arising from the use of these circuits, software, or information.
  2. Renesas Electronics hereby expressly disclaims any warranties against and liability for infringement or any other claims involving patents, copyrights, or other intellectual property rights of third parties, by or arising from the use of Renesas Electronics products or technical information described in this document, including but not limited to, the product data, drawings, charts, programs, algorithms, and application examples.
  3. No license, express, implied or otherwise, is granted hereby under any patents, copyrights or other intellectual property rights of Renesas Electronics or others.
  4. You shall be responsible for determining what licenses are required from any third parties, and obtaining such licenses for the lawful import, export, manufacture, sales, utilization, distribution or other disposal of any products incorporating Renesas Electronics products, if required.
  5. You shall not alter, modify, copy, or reverse engineer any Renesas Electronics product, whether in whole or in part. Renesas Electronics disclaims any and all liability for any losses or damages incurred by you or third parties arising from such alteration, modification, copying or reverse engineering.
  6. Renesas Electronics products are classified according to the following two quality grades: "Standard" and "High Quality". The intended applications for each Renesas Electronics product depends on the product's quality grade, as indicated below.
    - "Standard": Computers; office equipment; communications equipment; test and measurement equipment; audio and visual equipment; home electronic appliances; machine tools; personal electronic equipment; industrial robots; etc.
    - "High Quality": Transportation equipment (automobiles, trains, ships, etc.); traffic control (traffic lights); large-scale communication equipment; key financial terminal systems; safety control equipment; etc.
- Unless expressly designated as a high reliability product or a product for harsh environments in a Renesas Electronics data sheet or other Renesas Electronics document, Renesas Electronics products are not intended or authorized for use in products or systems that may pose a direct threat to human life or bodily injury (artificial life support devices or systems; surgical implantations; etc.), or may cause serious property damage (space system; undersea repeaters; nuclear power control systems; aircraft control systems; key plant systems; military equipment; etc.). Renesas Electronics disclaims any and all liability for any damages or losses incurred by you or any third parties arising from the use of any Renesas Electronics product that is inconsistent with any Renesas Electronics data sheet, user's manual or other Renesas Electronics document.
7. No semiconductor product is absolutely secure. Notwithstanding any security measures or features that may be implemented in Renesas Electronics hardware or software products, Renesas Electronics shall have absolutely no liability arising out of any vulnerability or security breach, including but not limited to any unauthorized access to or use of a Renesas Electronics product or a system that uses a Renesas Electronics product. RENESAS ELECTRONICS DOES NOT WARRANT OR GUARANTEE THAT RENESAS ELECTRONICS PRODUCTS, OR ANY SYSTEMS CREATED USING RENESAS ELECTRONICS PRODUCTS WILL BE INVULNERABLE OR FREE FROM CORRUPTION, ATTACK, VIRUSES, INTERFERENCE, HACKING, DATA LOSS OR THEFT, OR OTHER SECURITY INTRUSION ("Vulnerability Issues"). RENESAS ELECTRONICS DISCLAIMS ANY AND ALL RESPONSIBILITY OR LIABILITY ARISING FROM OR RELATED TO ANY VULNERABILITY ISSUES. FURTHERMORE, TO THE EXTENT PERMITTED BY APPLICABLE LAW, RENESAS ELECTRONICS DISCLAIMS ANY AND ALL WARRANTIES, EXPRESS OR IMPLIED, WITH RESPECT TO THIS DOCUMENT AND ANY RELATED OR ACCOMPANYING SOFTWARE OR HARDWARE, INCLUDING BUT NOT LIMITED TO THE IMPLIED WARRANTIES OF MERCHANTABILITY, OR FITNESS FOR A PARTICULAR PURPOSE.
  8. When using Renesas Electronics products, refer to the latest product information (data sheets, user's manuals, application notes, "General Notes for Handling and Using Semiconductor Devices" in the reliability handbook, etc.), and ensure that usage conditions are within the ranges specified by Renesas Electronics with respect to maximum ratings, operating power supply voltage range, heat dissipation characteristics, installation, etc. Renesas Electronics disclaims any and all liability for any malfunctions, failure or accident arising out of the use of Renesas Electronics products outside of such specified ranges.
  9. Although Renesas Electronics endeavors to improve the quality and reliability of Renesas Electronics products, semiconductor products have specific characteristics, such as the occurrence of failure at a certain rate and malfunctions under certain use conditions. Unless designated as a high reliability product or a product for harsh environments in a Renesas Electronics data sheet or other Renesas Electronics document, Renesas Electronics products are not subject to radiation resistance design. You are responsible for implementing safety measures to guard against the possibility of bodily injury, injury or damage caused by fire, and/or danger to the public in the event of a failure or malfunction of Renesas Electronics products, such as safety design for hardware and software, including but not limited to redundancy, fire control and malfunction prevention, appropriate treatment for aging degradation or any other appropriate measures. Because the evaluation of microcomputer software alone is very difficult and impractical, you are responsible for evaluating the safety of the final products or systems manufactured by you.
  10. Please contact a Renesas Electronics sales office for details as to environmental matters such as the environmental compatibility of each Renesas Electronics product. You are responsible for carefully and sufficiently investigating applicable laws and regulations that regulate the inclusion or use of controlled substances, including without limitation, the EU RoHS Directive, and using Renesas Electronics products in compliance with all these applicable laws and regulations. Renesas Electronics disclaims any and all liability for damages or losses occurring as a result of your noncompliance with applicable laws and regulations.
  11. Renesas Electronics products and technologies shall not be used for or incorporated into any products or systems whose manufacture, use, or sale is prohibited under any applicable domestic or foreign laws or regulations. You shall comply with any applicable export control laws and regulations promulgated and administered by the governments of any countries asserting jurisdiction over the parties or transactions.
  12. It is the responsibility of the buyer or distributor of Renesas Electronics products, or any other party who distributes, disposes of, or otherwise sells or transfers the product to a third party, to notify such third party in advance of the contents and conditions set forth in this document.
  13. This document shall not be reprinted, reproduced or duplicated in any form, in whole or in part, without prior written consent of Renesas Electronics.
  14. Please contact a Renesas Electronics sales office if you have any questions regarding the information contained in this document or Renesas Electronics products.

(Note1) "Renesas Electronics" as used in this document means Renesas Electronics Corporation and also includes its directly or indirectly controlled subsidiaries.

(Note2) "Renesas Electronics product(s)" means any product developed or manufactured by or for Renesas Electronics.

(Disclaimer Rev.5.0-1 October 2020)

## Corporate Headquarters

TOYOSU FORESIA, 3-2-24 Toyosu,  
Koto-ku, Tokyo 135-0061, Japan  
[www.renesas.com](http://www.renesas.com)

## Trademarks



Renesas and the Renesas logo are trademarks of Renesas Electronics Corporation. All trademarks and registered trademarks are the property of their respective owners.

## Contact Information

For further information on a product, technology, the most up-to-date version of a document, or your nearest sales office, please visit:  
[www.renesas.com/contact/](http://www.renesas.com/contact/)

## Looking for pricing, stock, or lifecycle information?

Click below to explore more details on WIN SOURCE:

-  [View ZSC31014EAG1-T on WIN SOURCE](#)
-  [IDT, Integrated Device Technology Inc Information](#)

## Optimize Your Supply Chain with WIN SOURCE Solutions

-  Global Sourcing Solution
-  Obsolete Management
-  Cost Control Management
-  Shortage Management
-  Alternative Solution
-  Excess Inventory Management