



**THE DATASHEET OF  
ADM3050ETRWZ-EP**



## FEATURES

- 5.7 kV rms signal isolated CAN FD transceiver
- 1.7 V to 5.5 V supply and logic side levels
- 4.5 V to 5.5 V supply on bus side
- ISO 11898-2:2016-compliant CAN FD
- Data rates up to 12 Mbps for CAN FD
- Low maximum loop propagation delay: 145 ns
- Extended common-mode range ( $V_{CANx}$ ):  $\pm 25$  V
- Bus fault protection (CANH, CANL):  $\pm 40$  V
- Passes EN 55022, Class B by 6 dB
- Safety and regulatory approvals**
  - VDE certificate of conformity, VDE V 0884-10 (pending)
  - UL: 5700 V rms for 1-minute duration per UL 1577 (pending)
  - CSA component acceptance 5A at 5.7 kV rms
  - IEC 60950, IEC 61010 (pending)
- High CMTI:  $>75$  kV/ $\mu$ s

## ENHANCED PRODUCT FEATURES

- Supports defense and aerospace applications (AQEC standard)
- Military temperature range ( $-55^{\circ}\text{C}$  to  $+125^{\circ}\text{C}$ )
- Controlled manufacturing baseline
- 1 assembly/test site
- 1 fabrication site
- Product change notification
- Qualification data available on request

## APPLICATIONS

- CANOpen, DeviceNet, and other CAN bus implementations
- Industrial automation
- Military and aerospace (MILA) avionics for sensors, actuators, and engine control

## GENERAL DESCRIPTION

The ADM3050E-EP is a 5.7 kV rms isolated controller area network (CAN) physical layer transceiver with a high performance, basic feature set. The ADM3050E-EP fully meets the CAN flexible data rate (CAN FD) ISO 11898-2:2016 requirements and is further capable of supporting data rates as high as 12 Mbps.

The device employs Analog Devices, Inc., *iCoupler*® technology to combine a 2-channel isolator and a CAN transceiver into a single small outline integrated circuit (SOIC) surface-mount package. The ADM3050E-EP is a fully isolated solution for CAN and CAN FD applications. The ADM3050E-EP provides isolation between the CAN controller and physical layer bus. Safety and regulatory approvals (pending) for a 5.7 kV rms

## FUNCTIONAL BLOCK DIAGRAM

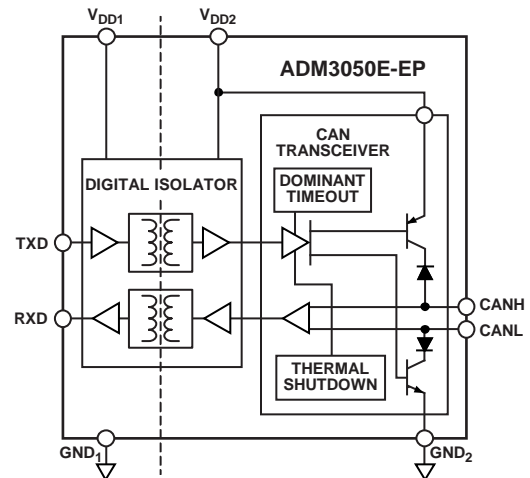

Figure 1.

17317-001

withstand voltage, an 849  $V_{PEAK}$  working voltage, and a 12.8 kV surge test, ensure that the ADM3050E-EP meets application isolation requirements.

Low loop propagation delays and the extended common-mode range of  $\pm 25$  V support robust communication on longer bus cables. Dominant timeout functionality protects against bus lock up in a fault condition, and current limiting and thermal shutdown features protect against output short circuits. The CAN bus input and output pins are protected to  $\pm 40$  V against accidental connection to a +24 V bus supply. The device is fully specified over the  $-55^{\circ}\text{C}$  to  $+125^{\circ}\text{C}$  industrial temperature range.

Additional application and technical information can be found in the [ADM3050E](#) data sheet.

Rev. 0

[Document Feedback](#)

Information furnished by Analog Devices is believed to be accurate and reliable. However, no responsibility is assumed by Analog Devices for its use, nor for any infringements of patents or other rights of third parties that may result from its use. Specifications subject to change without notice. No license is granted by implication or otherwise under any patent or patent rights of Analog Devices. Trademarks and registered trademarks are the property of their respective owners.

**TABLE OF CONTENTS**

Features .....	1	DIN V VDE V 0884-10 (VDE V 0884-10) Insulation Characteristics (Pending).....	7
Enhanced Product Features .....	1	Absolute Maximum Ratings .....	8
Applications.....	1	Thermal Resistance .....	8
Functional Block Diagram .....	1	ESD Caution.....	8
General Description .....	1	Pin Configuration and Function Descriptions.....	9
Revision History .....	2	Operational Truth Table .....	9
Specifications.....	3	Typical Performance Characteristics .....	10
Timing Specifications .....	5	Test Circuits.....	12
Insulation and Safety Related Specifications .....	6	Outline Dimensions .....	13
Package Characteristics .....	6	Ordering Guide .....	13
Regulatory Information.....	6		

**REVISION HISTORY**

2/2019—Revision 0: Initial Version

## SPECIFICATIONS

All voltages are relative to their respective ground,  $1.7\text{ V} \leq V_{DD1} \leq 5.5\text{ V}$ ,  $4.5\text{ V} \leq V_{DD2} \leq 5.5\text{ V}$ , and  $-55^\circ\text{C} \leq T_A \leq +125^\circ\text{C}$ , unless otherwise noted. Typical specifications are at  $V_{DD1} = V_{DD2} = 5\text{ V}$  and  $T_A = 25^\circ\text{C}$ , unless otherwise noted.

Table 1.

Parameter	Symbol	Min	Typ	Max	Unit	Test Conditions/Comments	
<b>SUPPLY CURRENT</b>							
Bus Side	$I_{DD2}$						
Recessive State			5.3	7	mA	TXD high, load resistance ( $R_L$ ) = 60 $\Omega$	
Dominant State			63	75	mA	Limited by transmit dominant timeout ( $t_{DT}$ ), $R_L = 60\ \Omega$	
					73	mA	Limited by $t_{DT}$ , $R_L = 60\ \Omega$ , $4.75\text{ V} \leq V_{DD2} \leq 5.25\text{ V}$
70% Dominant/30% Recessive							Worst case, $R_L = 60\ \Omega$
1 Mbps				45	58	mA	
5 Mbps			49	60	mA		
12 Mbps			58	65	mA		
Logic Side <i>i</i> Coupler Current	$I_{DD1}$			5.5	mA	TXD high, low, or switching	
<b>DRIVER</b>							
Differential Outputs						See Figure 18	
Recessive State Voltage						TXD high, $R_L$ , and common-mode filter capacitor ( $C_F$ ) open	
CANH, CANL	$V_{CANL}, V_{CANH}$	2.0		3.0	V		
Differential Output	$V_{OD}$	-500		+50	mV		
Dominant State Voltage						TXD low, $C_F$ open	
CANH	$V_{CANH}$	2.75		4.5	V	$50\ \Omega \leq R_L \leq 65\ \Omega$	
CANL	$V_{CANL}$	0.5		2.0	V	$50\ \Omega \leq R_L \leq 65\ \Omega$	
Differential Output	$V_{OD}$	1.5		3.0	V	$50\ \Omega \leq R_L \leq 65\ \Omega$	
		1.4		3.3	V	$45\ \Omega \leq R_L \leq 70$	
		1.5		5.0	V	$R_L = 2240\ \Omega$	
Output Symmetry ( $V_{DD2} - V_{CANH}$ to $V_{CANL}$ )	$V_{SYM}$	-0.55		+0.55	V	$R_L = 60\ \Omega$ , $C_F = 4.7\text{ nF}$	
Short-Circuit Current	$ I_{SC} $					$R_L$ open	
Absolute							
CANH				115	mA	$V_{CANH} = -3\text{ V}$	
CANL				115	mA	$V_{CANL} = 18\text{ V}$	
Steady State							
CANH				115	mA	$V_{CANH} = -24\text{ V}$	
CANL				115	mA	$V_{CANL} = 24\text{ V}$	
Logic Input TXD							
Input Voltage							
High	$V_{IH}$	$0.65 \times V_{DD1}$			V		
Low	$V_{IL}$			$0.35 \times V_{DD1}$	V		
Complementary Metal-Oxide Semiconductor (CMOS) Logic Input Currents	$ I_{IH} ,  I_{IL} $			10	$\mu\text{A}$	Input high or low	
<b>RECEIVER</b>							
Differential Inputs							
Differential Input Voltage Range	$V_{ID}$					See Figure 19, RXD capacitance ( $C_{RXD}$ ) open, $-25\text{ V} < V_{CANL}, V_{CANH} < +25\text{ V}$	
Recessive		-1.0		+0.5	V		
Dominant		0.9		5.0	V		
Input Voltage Hysteresis	$V_{HYS}$		150		mV		
Unpowered Input Leakage Current	$ I_{IN(OFF)} $			10	$\mu\text{A}$	$V_{CANH}, V_{CANL} = 5\text{ V}, V_{DD2} = 0\text{ V}$	

Parameter	Symbol	Min	Typ	Max	Unit	Test Conditions/Comments
Input Resistance						
CANH, CANL	$R_{INH}, R_{INL}$	6		25	k $\Omega$	
Differential	$R_{DIFF}$	20		100	k $\Omega$	
Input Resistance Matching	$m_R$	-0.03		+0.03		$m_R = 2 \times (R_{INH} - R_{INL}) / (R_{INH} + R_{INL})$
CANH, CANL Input Capacitance	$C_{INH}, C_{INL}$		35		pF	
Differential Input Capacitance	$C_{DIFF}$		12		pF	
Logic Output (RXD)						
Output Voltage						
Low	$V_{OL}$		0.2	0.4	V	Output impedance ( $I_{OUT}$ ) = 2 mA
High	$V_{OH}$	$V_{DD1} - 0.2$			V	$I_{OUT} = -2$ mA
Short-Circuit Current	$I_{OS}$	7		85	mA	Output voltage ( $V_{OUT}$ ) = GND <sub>1</sub> or $V_{DD1}$
COMMON-MODE TRANSIENT IMMUNITY (CMTI) <sup>1</sup>						Common-mode voltage ( $V_{CM}$ ) $\geq$ 1 kV, transient magnitude $\geq$ 800 V
Input High, Recessive	$ CM_H $	75	100		kV/ $\mu$ s	Input voltage ( $V_{IN}$ ) = $V_{DD1}$ (TXD) or CANH/CANL recessive
Input Low, Dominant	$ CM_L $	75	100		kV/ $\mu$ s	$V_{IN} = 0$ V (TXD) or CANH/CANL dominant

<sup>1</sup>  $|CM_H|$  is the maximum common-mode voltage slew rate that can be sustained while maintaining CANH/CANL recessive or  $RXD \geq V_{DD1} - 0.2$  V.  $|CM_L|$  is the maximum common-mode voltage slew rate that can be sustained while maintaining CANH/CANL dominant or  $RXD \leq 0.4$  V. The common-mode voltage slew rates apply to both rising and falling common-mode voltage edges.

**TIMING SPECIFICATIONS**

All voltages are relative to their respective ground,  $1.7\text{ V} \leq V_{DD1} \leq 5.5\text{ V}$ ,  $4.5\text{ V} \leq V_{DD2} \leq 5.5\text{ V}$ , and  $-55^\circ\text{C} \leq T_A \leq +125^\circ\text{C}$ , unless otherwise noted. Typical specifications are at  $V_{DD1} = V_{DD2} = 5\text{ V}$  and  $T_A = 25^\circ\text{C}$ , unless otherwise noted. See the [ADM3050E](#) data sheet for information about  $t_{BIT\_BUS}$ .

**Table 2.**

Parameter	Symbol	Min	Typ	Max	Unit	Test Conditions/Comments
<b>DRIVER</b>						
Maximum Data Rate		12			Mbps	See Figure 2 and Figure 18, $t_{BIT\_TXD} = 200\text{ ns}$ , $R_L = 60\ \Omega$ , $C_L = 100\text{ pF}$
Propagation Delay from TXD to Bus (Recessive to Dominant)	$t_{TXD\_DOM}$		35	60	ns	
Propagation Delay from TXD to Bus (Dominant to Recessive)	$t_{TXD\_REC}$		45	70	ns	
Transmit Dominant Timeout	$t_{DT}$	1175		4000	$\mu\text{s}$	TXD low, see Figure 3
<b>RECEIVER</b>						
Falling Edge Loop Propagation Delay (TXD to RXD)	$t_{LOOP\_FALL}$			145	ns	
Rising Edge Loop Propagation Delay (TXD to RXD)	$t_{LOOP\_RISE}$			145	ns	
Loop Delay Symmetry (Minimum Recessive Bit Width)	$t_{BIT\_RXD}$					
2 Mbps		450		550	ns	$t_{BIT\_TXD} = 500\text{ ns}$
5 Mbps		160		220	ns	$t_{BIT\_TXD} = 200\text{ ns}$
8 Mbps		85		140	ns	$t_{BIT\_TXD} = 125\text{ ns}$
12 Mbps		50		91.6	ns	$t_{BIT\_TXD} = 83.3\text{ ns}$

**Timing Diagrams**

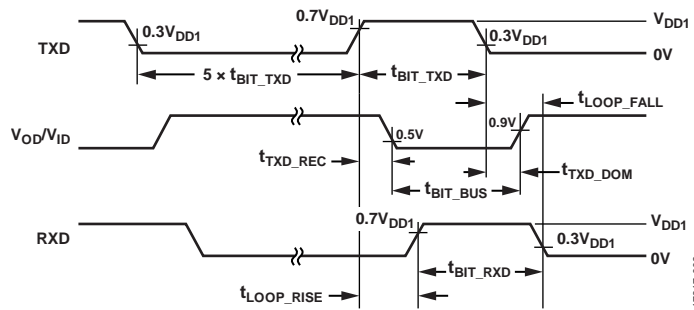

Figure 2. Transceiver Timing Diagram

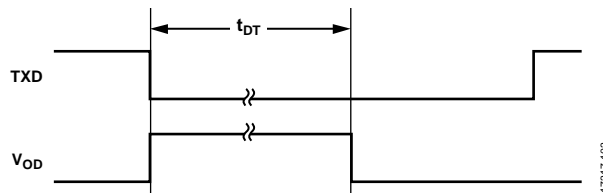

Figure 3. Dominant Timeout,  $t_{DT}$

**INSULATION AND SAFETY RELATED SPECIFICATIONS**

For additional information, see [www.analog.com/icouplersafety](http://www.analog.com/icouplersafety).

Table 3.

Parameter	Symbol	Value	Unit	Test Conditions/Comments
Rated Dielectric Insulation Voltage		5700	V rms	1-minute duration
Minimum External Air Gap (Clearance)	L (I01)	7.8	mm min	Measured from input terminals to output terminals, shortest distance through air
Minimum External Tracking (Creepage)	L (I02)	7.8	mm min	Measured from input terminals to output terminals, shortest distance path along body
Minimum Clearance in the Plane of the Printed Circuit Board (PCB) Clearance	L (PCB)	8.3	mm min	Measured from input terminals to output terminals, shortest distance through air, line of sight, in the PCB mounting plane
Minimum Internal Gap (Internal Clearance)		25.5	μm min	Insulation distance through insulation
Tracking Resistance (Comparative Tracking Index)	CTI	>600	V	DIN IEC 112/VDE 0303 Part 1
Material Group		I		Material group (DIN VDE 0110, 1/89, Table 1)

**PACKAGE CHARACTERISTICS**

Table 4.

Parameter	Symbol	Min	Typ	Max	Unit	Test Conditions/Comments
Resistance (Input to Output) <sup>1</sup>	R <sub>I-O</sub>		10 <sup>13</sup>		Ω	
Capacitance (Input to Output) <sup>1</sup>	C <sub>I-O</sub>		1.1		pF	f = 1 MHz
Input Capacitance <sup>2</sup>	C <sub>I</sub>		4.0		pF	

<sup>1</sup> The device is considered a two-terminal device: Pin 1 through Pin 8 are shorted together, and Pin 9 through Pin 16 are shorted together.

<sup>2</sup> Input capacitance is from any input data pin to ground.

**REGULATORY INFORMATION**

See Table 9 and the [ADM3050E](#) data sheet for the recommended maximum working voltages for specific cross isolation waveforms and insulation levels. The ADM3050E-EP is pending approval or approved by the organizations listed in Table 5.

Table 5.

UL (Pending)	CSA (Pending)	VDE (Pending)	CQC (Pending)
UL1577 Component Recognition Program <sup>1</sup> Single Protection, 5700 V rms Isolation Voltage	Approved under CSA Component Acceptance Notice 5A CSA 60950-1-07+A1+A2 and IEC 60950-1, second edition, +A1+A2: Basic insulation at 780 V rms (1103 V <sub>PEAK</sub> ) Reinforced insulation at 390 V rms (552 V <sub>PEAK</sub> ) IEC 60601-1 Edition 3.1: Basic insulation (1 MOPP), 490 V rms (686 V <sub>PEAK</sub> ) Reinforced insulation (2 MOPP), 238 V rms (325 V <sub>PEAK</sub> ) CSA 61010-1-12 and IEC 61010-1 third edition: Basic insulation at: 300 V rms mains, 780 V secondary (1103 V <sub>PEAK</sub> ) Reinforced insulation at: 300 V rms mains, 390 V secondary (552 V <sub>PEAK</sub> )	DIN V VDE V 0884-10 (VDE V 0884-10):2006-12 <sup>2</sup> Reinforced insulation, 849 V <sub>PEAK</sub> , V <sub>IOTM</sub> = 8 kV <sub>PEAK</sub>	Certified under CQC11-471543-2012 GB4943.1-2011 Basic insulation at 780 V rms (1103 V <sub>PEAK</sub> ) Reinforced insulation at 390 V rms (552 V <sub>PEAK</sub> )
File E214100	File 205078	File 2471900-4880-0001	File (pending)

<sup>1</sup> In accordance with UL 1577, each ADM3050E-EP is proof tested by applying an insulation test voltage ≥ 6840 V rms for 1 sec.

<sup>2</sup> In accordance with DIN V VDE V 0884-10, each ADM3050E-EP is proof tested by applying an insulation test voltage ≥ 1592 V peak for 1 sec (partial discharge detection limit = 5 pC). The \* marking branded on the component designates DIN V VDE V 0884-10 approval.

**DIN V VDE V 0884-10 (VDE V 0884-10) INSULATION CHARACTERISTICS (PENDING)**

These isolators are suitable for reinforced electrical isolation only within the safety limit data. Protective circuits ensure the maintenance of the safety data.

**Table 6.**

Description	Test Conditions/Comments	Symbol	Characteristic	Unit
Installation Classification per DIN VDE 0110 For Rated Mains Voltage ≤ 150 V rms For Rated Mains Voltage ≤ 300 V rms For Rated Mains Voltage ≤ 600 V rms Climatic Classification Pollution Degree per DIN VDE 0110, Table 1			I to IV I to IV I to IV 40/125/21 2	
Maximum Working Insulation Voltage Reinforced Basic, DC Working Voltage	See the Absolute Maximum Ratings section and Table 9 for the maximum continuous working voltage for ac bipolar, ac unipolar, and dc voltages, basic and reinforced insulation, and 50 year lifetime to 1% failure	$V_{IORM}$ $V_{IORM(DC)}$	849 1500	$V_{PEAK}$ $V_{DC}$
Input to Output Test Voltage, Method B1	$V_{IORM} \times 1.875 = V_{pd(m)}$ , 100% production test, $t_{ini} = t_m = 1$ sec, partial discharge < 5 pC	$V_{pd(m)}$	1592	$V_{PEAK}$
Input to Output Test Voltage, Method A After Environmental Tests Subgroup 1  After Input and/or Safety Test Subgroup 2 and Subgroup 3	$V_{IORM} \times 1.5 = V_{pd(m)}$ , $t_{ini} = 60$ sec, $t_m = 10$ sec, partial discharge < 5 pC  $V_{IORM} \times 1.2 = V_{pd(m)}$ , $t_{ini} = 60$ sec, $t_m = 10$ sec, partial discharge < 5 pC	$V_{pd(m)}$	1274 1019	$V_{PEAK}$ $V_{PEAK}$
Highest Allowable Overvoltage Impulse	1.2 μs rise time, 50 μs, 50% fall time in air to the preferred sequence	$V_{IOTM}$ $V_{IMPULSE}$	8000 8000	$V_{PEAK}$ $V_{PEAK}$
Surge Isolation Voltage Basic Reinforced	$V_{PEAK} = 12.8$ kV, 1.2 μs rise time, 50 μs, and 50% fall time $V_{PEAK} = 12.8$ kV, 1.2 μs rise time, 50 μs, and 50% fall time	$V_{IOSM}$ $V_{IOSM}$	12000 8000	$V_{PEAK}$ $V_{PEAK}$ $V_{PEAK}$
Safety Limiting Values Maximum Junction Temperature Total Power Dissipation at 25°C Insulation Resistance at $T_s$	Maximum value allowed in the event of a failure (see Figure 4)  Test voltage = 500 V	$T_s$ $P_s$ $R_s$	150 2.08 >10 <sup>9</sup>	°C W Ω

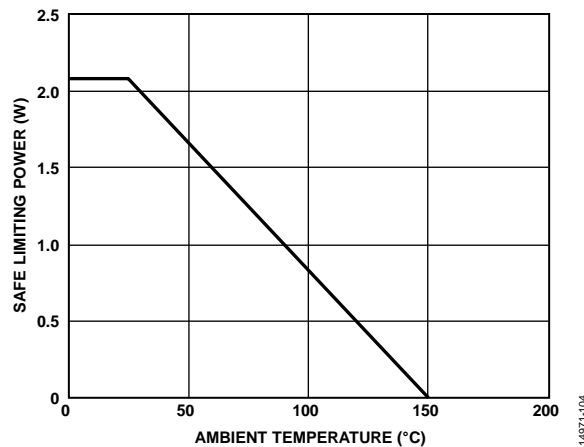

Figure 4. Thermal Derating Curve, Dependence of Safety Limiting Values with Ambient Temperature per DIN V VDE V 0884-10 (See the Thermal Resistance Section for Additional Information)

## ABSOLUTE MAXIMUM RATINGS

Pin voltages with respect to GND<sub>1</sub>/GND<sub>2</sub> are on same side, unless otherwise noted.

Table 7.

Parameter	Rating
V <sub>DD1</sub> /V <sub>DD2</sub>	-0.5 V to +6 V
Logic Side Input and Output: TXD, RXD	-0.5 V to V <sub>DD1</sub> + 0.5 V
CANH, CANL	-40 V to +40 V
Operating Temperature Range	-55°C to +125°C
Storage Temperature Range	-65°C to +150°C
Maximum Junction Temperature (T <sub>j</sub> )	150°C
Electrostatic Discharge (ESD), IEC 61000-4-2, CANH/CANL	
Across Isolation Barrier with Respect to GND <sub>1</sub>	±8 kV
Contact Discharge with Respect to GND <sub>2</sub>	±8 kV typical
Air Discharge with Respect to GND <sub>2</sub>	±15 kV
Human Body Model (HBM), All Pins, 1.5 kΩ, 100 pF	±4 kV
Moisture Sensitivity Level (MSL)	MSL3

Stresses at or above those listed under Absolute Maximum Ratings may cause permanent damage to the product. This is a stress rating only; functional operation of the product at these or any other conditions above those indicated in the operational section of this specification is not implied. Operation beyond the maximum operating conditions for extended periods may affect product reliability.

Table 9. Maximum Continuous Working Voltage<sup>1</sup>

Parameter	Insulation Rating (20-Year Lifetime) <sup>2</sup>	VDE 0884-11 Lifetime Conditions Fulfilled
AC Voltage		
Bipolar Waveform		
Basic Insulation	849 V <sub>PEAK</sub>	Lifetime limited by insulation lifetime per VDE-0884-11
Reinforced Insulation	707 V <sub>PEAK</sub>	Lifetime limited by insulation lifetime per VDE-0884-11
Unipolar Waveform		
Basic Insulation	1697 V <sub>PEAK</sub>	Lifetime limited by insulation lifetime per VDE-0884-11
Reinforced Insulation	1275 V <sub>PEAK</sub>	Lifetime limited by package creepage per IEC 60664-1
DC Voltage		
Basic Insulation	1560 V <sub>PEAK</sub>	Lifetime limited by package creepage per IEC 60664-1
Reinforced Insulation	780 V <sub>PEAK</sub>	Lifetime limited by package creepage per IEC 60664-1

<sup>1</sup> The maximum continuous working voltage refers to the continuous voltage magnitude imposed across the isolation barrier. See the ADM3050E data sheet for more details.

<sup>2</sup> Insulation capability without regard to creepage limitations. Working voltage may be limited by the PCB creepage when considering rms voltages for components soldered to a PCB (assumes Material Group I up to 1250 V rms), or by the SOIC\_W package creepage of 7.8 mm, when considering rms voltages for Material Group II.

## THERMAL RESISTANCE

Thermal performance is directly linked to PCB design and operating environment. Careful attention to PCB thermal design is required.

The thermal resistance value specified in Table 8 is simulated based on JEDEC specifications (unless specified otherwise) and must be used in compliance with JESD51-12.

Table 8. Thermal Resistance

Package Type	θ <sub>JA</sub>	Unit
RW-16 <sup>1</sup>	60	°C/W

<sup>1</sup> The θ<sub>JA</sub> value is based on simulations of a devices mounted on a JEDEC standard, 4-layer board with fine width traces and still air. See the ADM3050E data sheet for the thermal model definitions.

## ESD CAUTION



**ESD (electrostatic discharge) sensitive device.** Charged devices and circuit boards can discharge without detection. Although this product features patented or proprietary protection circuitry, damage may occur on devices subjected to high energy ESD. Therefore, proper ESD precautions should be taken to avoid performance degradation or loss of functionality.

## PIN CONFIGURATION AND FUNCTION DESCRIPTIONS

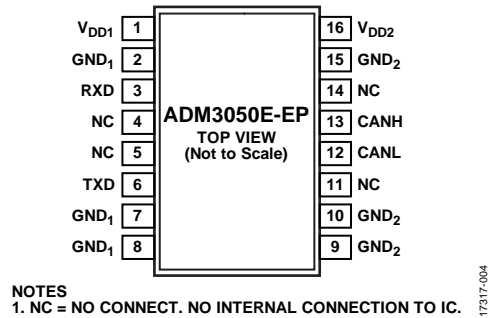

Figure 5. Pin Configuration

Table 10. Pin Function Descriptions

Pin No.	Mnemonic	Description
1	V <sub>DD1</sub>	Power Supply, Logic Side, 1.7 V to 5.5 V. This pin requires a 0.1 $\mu$ F decoupling capacitor.
2, 7, 8	GND <sub>1</sub>	Ground, Logic Side.
3	RXD	Receiver Output Data.
4, 5, 11, 14	NC	No Connect. No internal connection to IC.
6	TXD	Driver Input Data.
9, 10, 15	GND <sub>2</sub>	Ground, Bus Side.
12	CANL	CAN Low Input and Output.
13	CANH	CAN High Input and Output.
16	V <sub>DD2</sub>	Power Supply, Bus Side, 4.5 V to 5.5 V. This pin requires a 0.1 $\mu$ F decoupling capacitor.

## OPERATIONAL TRUTH TABLE

Table 11. Truth Table

V <sub>DD1</sub>	V <sub>DD2</sub>	TXD	Mode	RXD	CANH/CANL
On	On	Low	Normal	Low	Dominant (limited by t <sub>DT</sub> )
On	On	High	Normal	High per bus	Recessive and set by bus
Off	On	Don't care	Normal	Indeterminate	Recessive and set by bus
On	Off	Don't care	Transceiver off	High	High-Z

# TYPICAL PERFORMANCE CHARACTERISTICS

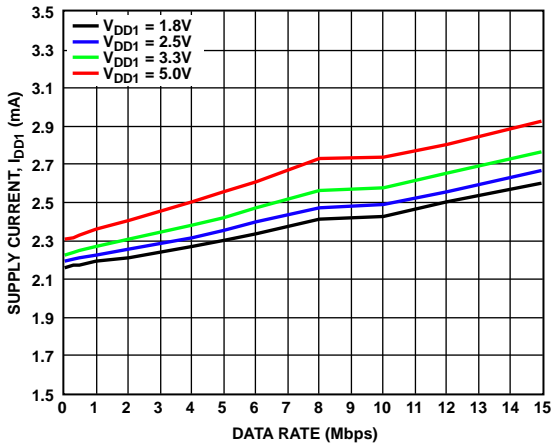

Figure 6. Supply Current ( $I_{DD1}$ ) vs. Data Rate

17317-108

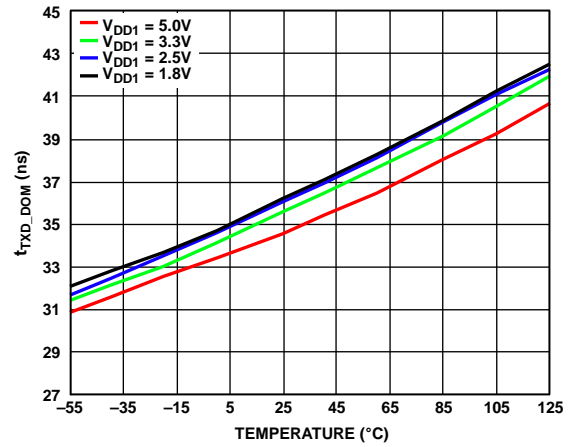

Figure 9.  $t_{TXD\_DOM}$  vs. Temperature

17317-109

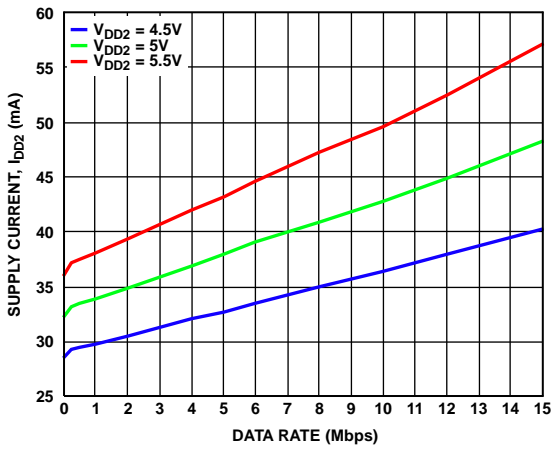

Figure 7. Supply Current ( $I_{DD2}$ ) vs. Data Rate

17317-107

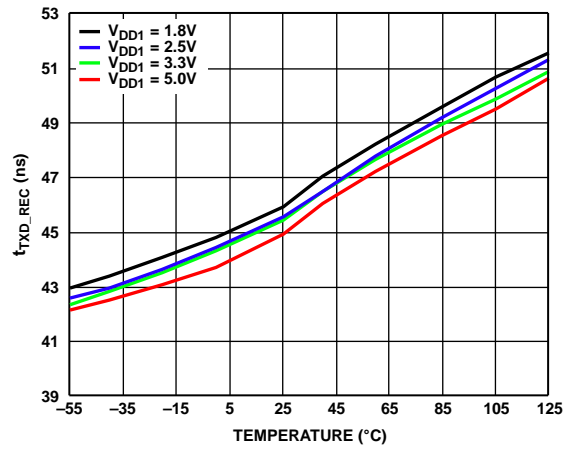

Figure 10.  $t_{TXD\_REC}$  vs. Temperature

17317-110

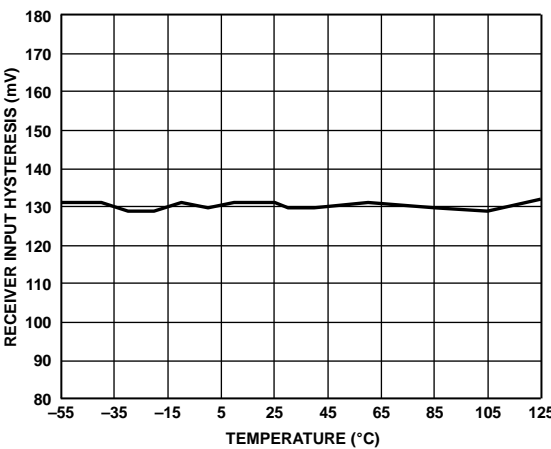

Figure 8. Receiver Input Hysteresis vs. Temperature

17317-108

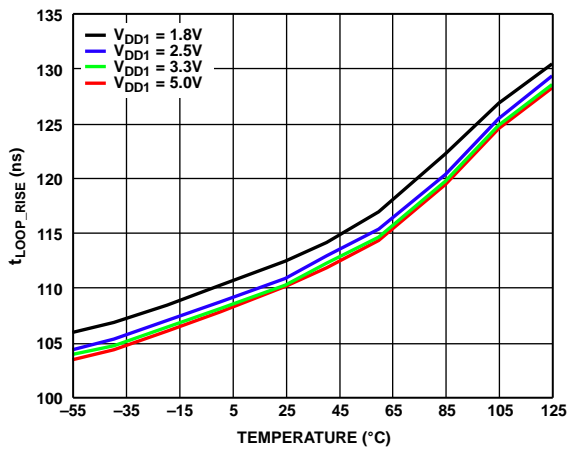

Figure 11.  $t_{LOOP\_RISE}$  vs. Temperature

17317-111

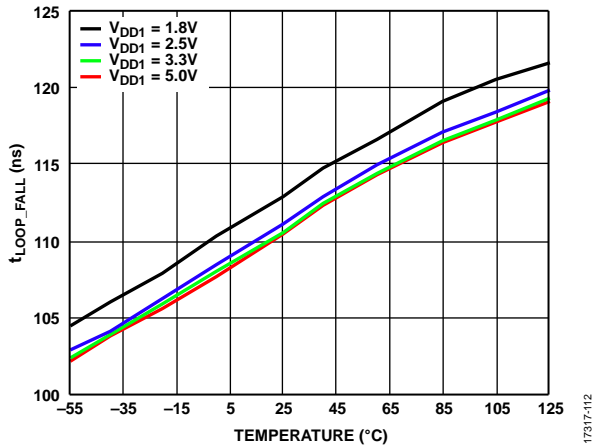

Figure 12.  $t_{LOOP\_FALL}$  vs. Temperature

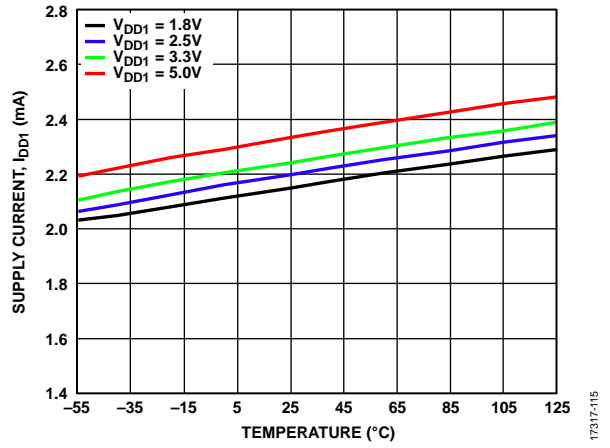

Figure 15. Supply Current ( $I_{DD1}$ ) vs. Temperature

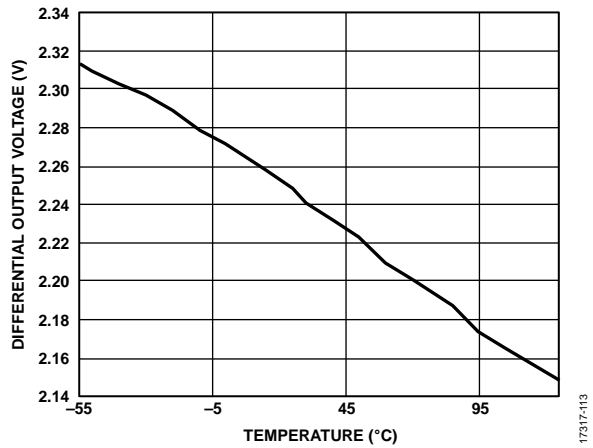

Figure 13. Differential Output Voltage vs. Temperature,  $R_L = 60 \Omega$

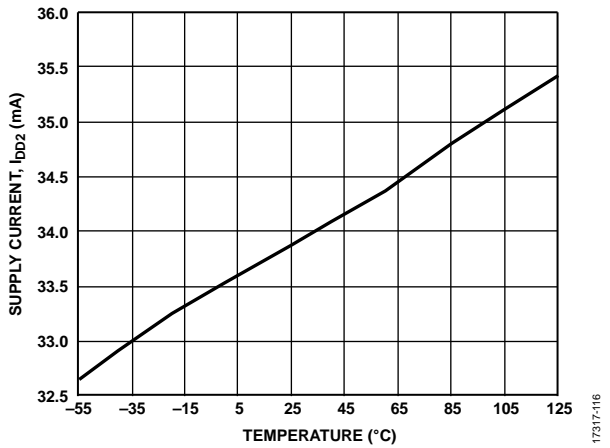

Figure 16. Supply Current ( $I_{DD2}$ ) vs. Temperature

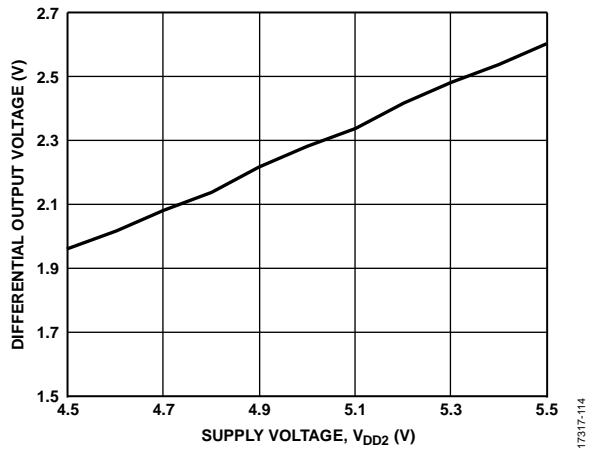

Figure 14. Differential Output Voltage vs. Supply Voltage ( $V_{DD2}$ ),  $R_L = 60 \Omega$

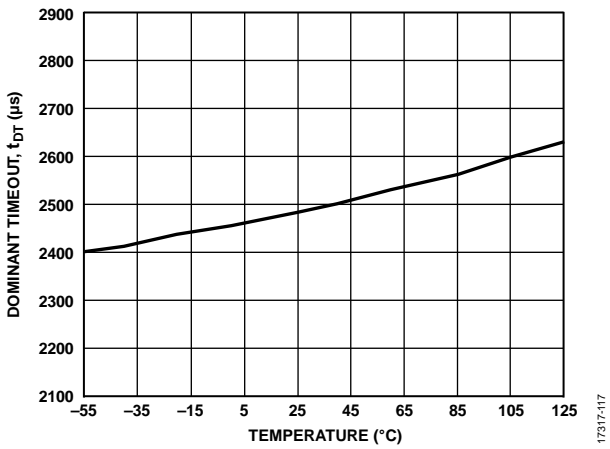

Figure 17. Dominant Timeout ( $t_{DT}$ ) vs. Temperature

TEST CIRCUITS

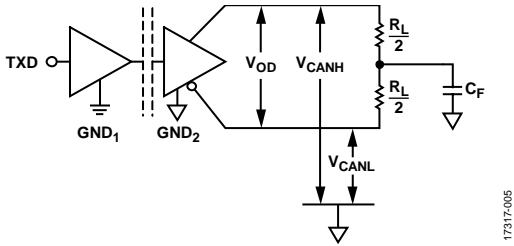

Figure 18. Driver Voltage Measurement

17317-005

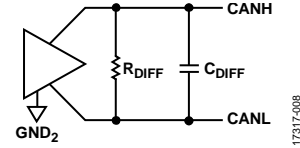

Figure 21.  $R_{DIFF}$  and  $C_{DIFF}$  Measured in Recessive State, Bus Disconnected

17317-008

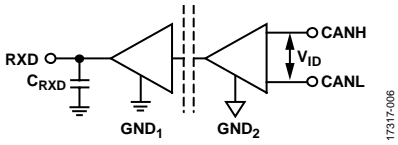

Figure 19. Receiver Voltage Measurement

17317-006

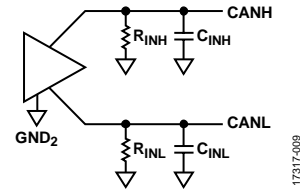
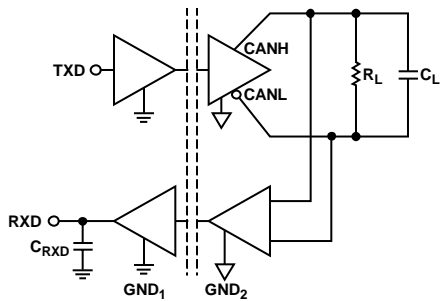

Figure 22. Input Resistance ( $R_{INx}$ ) and Input Capacitance ( $C_{INx}$ ) Measured in Recessive State, Bus Disconnected

17317-009



NOTES  
1. 1% TOLERANCE FOR ALL RESISTORS AND CAPACITORS.

Figure 20. Switching Characteristics Measurements

17317-007

# OUTLINE DIMENSIONS

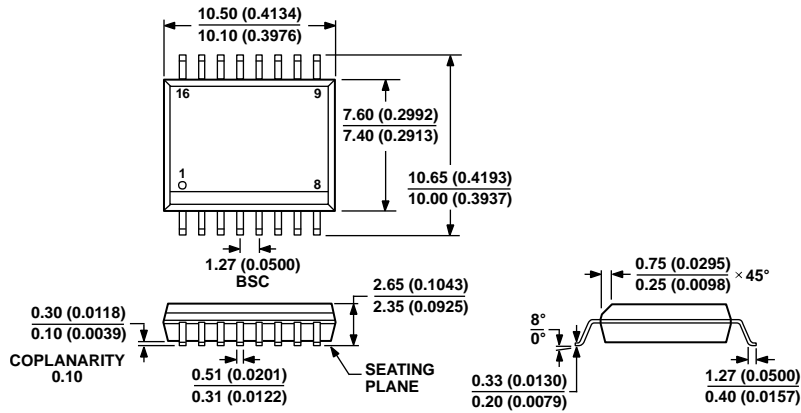

COMPLIANT TO JEDEC STANDARDS MS-013-AA  
 CONTROLLING DIMENSIONS ARE IN MILLIMETERS; INCH DIMENSIONS  
 (IN PARENTHESES) ARE ROUNDED-OFF MILLIMETER EQUIVALENTS FOR  
 REFERENCE ONLY AND ARE NOT APPROPRIATE FOR USE IN DESIGN.

03-27-2007-B

Figure 23. 16-Lead Standard Small Outline Package [SOIC\_W]  
 Wide Body  
 (RW-16)  
 Dimensions shown in millimeters and (inches)

## ORDERING GUIDE

Model <sup>1</sup>	Temperature Range	Package Description	Package Option
ADM3050ETRWZ-EP	-55°C to +125°C	16-Lead Standard Small Outline Package [SOIC_W]	RW-16
ADM3050ETRWZ-EP-RL	-55°C to +125°C	16-Lead Standard Small Outline Package [SOIC_W]	RW-16
EVAL-ADM3050EEBZ		Evaluation Board	

<sup>1</sup> Z = RoHS Compliant Part.

## Looking for pricing, stock, or lifecycle information?

Click below to explore more details on WIN SOURCE:

 [View ADM3050ETRWZ-EP on WIN SOURCE](#)

 [Analog Devices Inc. Information](#)

## Optimize Your Supply Chain with WIN SOURCE Solutions

-  Global Sourcing Solution
-  Obsolete Management
-  Cost Control Management
-  Shortage Management
-  Alternative Solution
-  Excess Inventory Management