



**THE DATASHEET OF
NCL31001MNITWG**



ON Semiconductor

Is Now

onsemi™

To learn more about onsemi™, please visit our website at
www.onsemi.com

onsemi and **onsemi** and other names, marks, and brands are registered and/or common law trademarks of Semiconductor Components Industries, LLC dba "**onsemi**" or its affiliates and/or subsidiaries in the United States and/or other countries. **onsemi** owns the rights to a number of patents, trademarks, copyrights, trade secrets, and other intellectual property. A listing of **onsemi** product/patent coverage may be accessed at www.onsemi.com/site/pdf/Patent-Marking.pdf. **onsemi** reserves the right to make changes at any time to any products or information herein, without notice. The information herein is provided "as-is" and **onsemi** makes no warranty, representation or guarantee regarding the accuracy of the information, product features, availability, functionality, or suitability of its products for any particular purpose, nor does **onsemi** assume any liability arising out of the application or use of any product or circuit, and specifically disclaims any and all liability, including without limitation special, consequential or incidental damages. Buyer is responsible for its products and applications using **onsemi** products, including compliance with all laws, regulations and safety requirements or standards, regardless of any support or applications information provided by **onsemi**. "Typical" parameters which may be provided in **onsemi** data sheets and/or specifications can and do vary in different applications and actual performance may vary over time. All operating parameters, including "Typicals" must be validated for each customer application by customer's technical experts. **onsemi** does not convey any license under any of its intellectual property rights nor the rights of others. **onsemi** products are not designed, intended, or authorized for use as a critical component in life support systems or any FDA Class 3 medical devices or medical devices with a same or similar classification in a foreign jurisdiction or any devices intended for implantation in the human body. Should Buyer purchase or use **onsemi** products for any such unintended or unauthorized application, Buyer shall indemnify and hold **onsemi** and its officers, employees, subsidiaries, affiliates, and distributors harmless against all claims, costs, damages, and expenses, and reasonable attorney fees arising out of, directly or indirectly, any claim of personal injury or death associated with such unintended or unauthorized use, even if such claim alleges that **onsemi** was negligent regarding the design or manufacture of the part. **onsemi** is an Equal Opportunity/Affirmative Action Employer. This literature is subject to all applicable copyright laws and is not for resale in any manner. Other names and brands may be claimed as the property of others.

Complete Connected LED Driver Power Solution

NCL31000, NCL31001

Description

The NCL31000 is a new member of the ON Semiconductor LED driver family specifically targeting luminaire applications. NCL31000 incorporates a high efficient buck LED driver. The LED driver supports both high-bandwidth analog dimming and PWM dimming down to zero current. NCL31000 includes an integrated fixed 3V3 DC-DC and one adjustable DC-DC. A diagnostics block incorporates an ADC, which measures input and LED output currents, voltages, LED temperature, DC/DC voltages and currents. Fast safety mechanisms protect the critical blocks of the chip. The diagnostic measurements are available together with a flexible status reporting and interrupt mechanism. NCL31001 is the same as NCL31000 except that it does not include both DC-DC converters. The combination of NCL31000 and NCL31001 is ideal for dual channel solutions.

Features

- Wide Input Voltage Range: 21.5 V to 57 V
- Proprietary 100 W+ Applications
- Integrated 3.3 V Buck Convertor (Only for NCL31000)
- Integrated Adjustable Buck Convertor 2.5 – 24 V (Only for NCL31000)
- Integrated High Efficiency Buck LED Driver
- Adjustable Switching Frequency 44.4 kHz to 1 MHz
- Deep Dimming to Zero with Accuracy of 0.1% Using Internal Precision 2.4 V Reference
- Best in Class Linearity
- High Modulation Bandwidth (~50 kHz)
 - ◆ Visual Light Communication Capable
 - ◆ Yellow-Dot™ Compliant
- Internal DIM DAC for Independent LED Control During Micro-controller Re-flashing (Warm Boot)
- Low EMI Reference Design
- I²C/SPI Interface (I/S Suffix)
- High Accuracy Diagnostic Functions to Measure Voltages/Currents
- Protection against LED Shorts & Opens
- LED Over/Under Voltage & Over Current Protection
- Chip Over Current Protection
- Chip & LED Over Temperature Protection
- Junction Temperature Range of -40°C to +125°C
- Available in 48-pin QFN 7x7
- These Devices are Pb-Free and are RoHS Compliant



ON Semiconductor®

www.onsemi.com

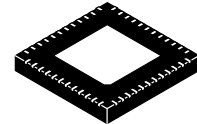

QFN48 7x7, 0.5P
CASE 485EP

MARKING DIAGRAM

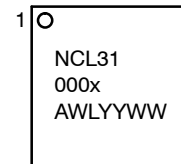

NCL31000

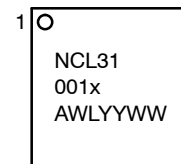

NCL31001

NCL31000x = Specific Device Code (x = I or S)
NCL31001x
A = Assembly Location
WL = Wafer Lot
YY = Year
WW = Work Week

ORDERING INFORMATION

See detailed ordering and shipping information on page 2 of this data sheet.

NCL31000, NCL31001

DEVICE ORDERING INFORMATION

Device	DC-DC Converters	Serial Bus	Shipping†
NCL31000MNITWG	Yes	I ² C	2500 / Tape & Reel
NCL31000MNSTWG	Yes	SPI	2500 / Tape & Reel
NCL31001MNITWG	No	I ² C	2500 / Tape & Reel
NCL31001MNSTWG	No	SPI	2500 / Tape & Reel

†For information on tape and reel specifications, including part orientation and tape sizes, please refer to our Tape and Reel Packaging Specifications Brochure, BRD8011/D.

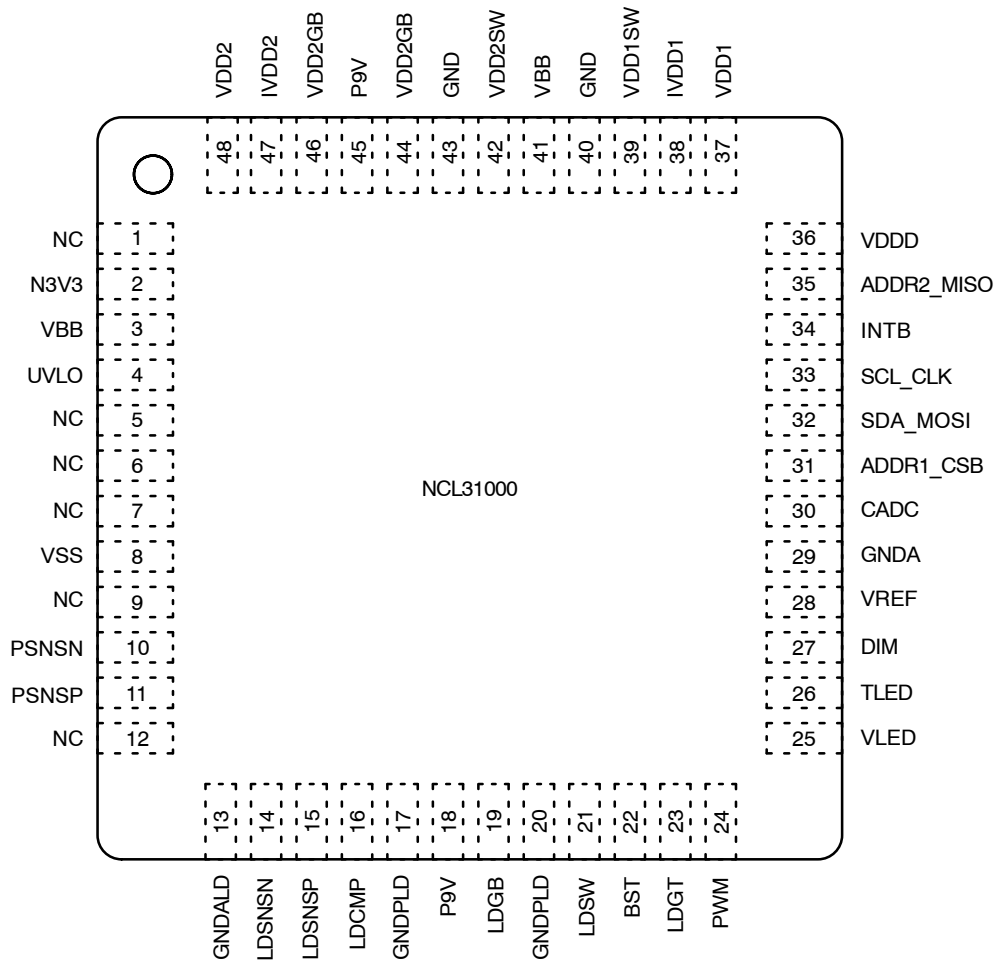

Figure 1. Pin-out NCL31000 in 48-pin QFN (Top View)

NCL31000, NCL31001

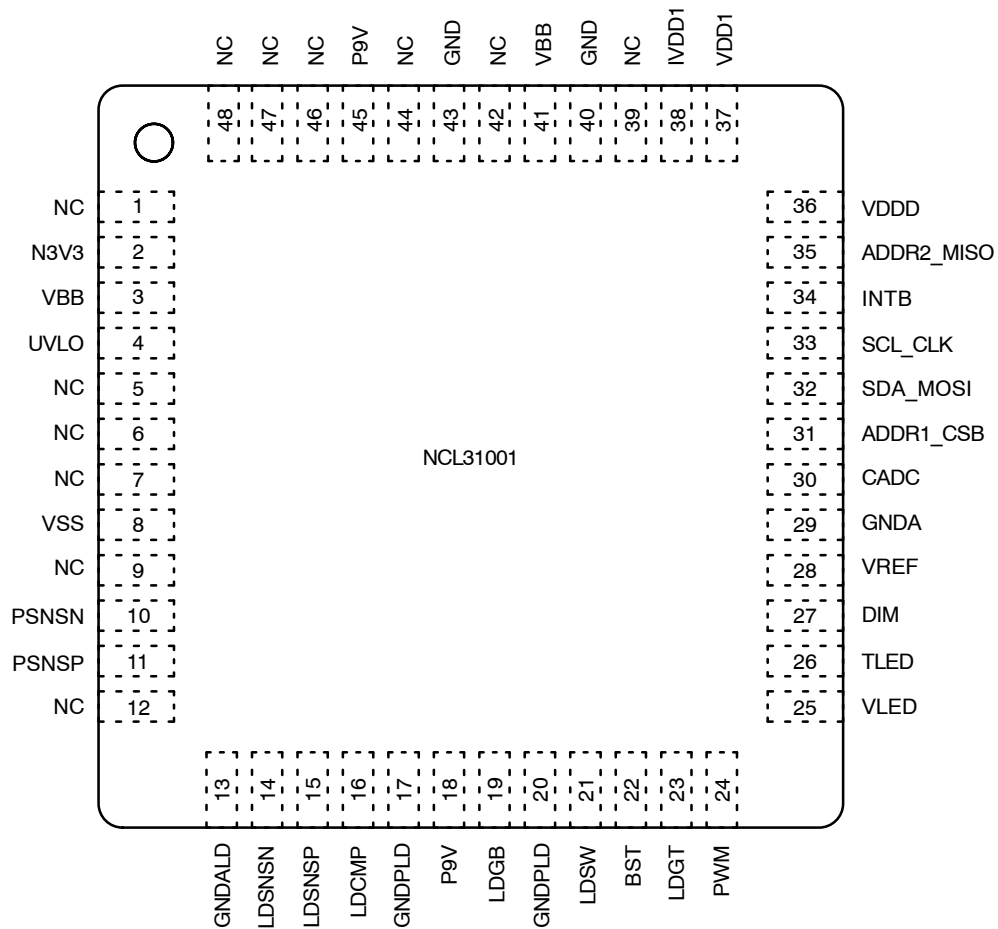

Figure 2. Pin-out NCL31001 in 48-pin QFN (Top View)

PIN DESCRIPTION

Pin No.	Signal Name	Type	Description
1	NC		
2	N3V3	Power	-3V3 LDO output. Decouple to VBB (pin 3) with a 1 μ F capacitor.
3	VBB	Power	Positive input power. Connect to the positive terminal of the DC power supply.
4	UVLO	Analog	Under-voltage lockout pin. Keep capacitance on this pin versus VSS below 100 pF
5	NC		
6	NC		
7	NC		
8	VSS	Power	Negative input power. Connect to the negative terminal of the DC power supply.
9	NC		
10	PSNSN	Input	Negative input current sense line. Connect to VSS at the negative side of the external input current sense resistor.
11	PSNSP	Input	Positive input current sense line. Connect to the positive side of the external input current sense resistor.
12	NC		
13	GNDALD	Power	Application ground. Return for the LED Buck compensation network.
14	LDSNSN	Input	Negative LED current sense line. Connect to the GND side of LDSNS.
15	LDSNSP	Input	Positive LED current sense line. Connect to the positive side of LDSNS.

NCL31000, NCL31001

PIN DESCRIPTION (continued)

Pin No.	Signal Name	Type	Description
16	LDCOMP	Analog	Compensation pin for the LED driver.
17	RTNPLD	Power	Application ground. LED Buck power return.
18	P9V	Power	9 V gate drive voltage regulator output. Decouple to GNDPLD with a 1 μ F capacitor. Connect to P9V (pin 45) with a trace on the PCB.
19	LDGB	Output	LED buck convertor bottom switch gate driver.
20	GNDPLD	Power	Application ground. LED Buck power return.
21	LDSW	Power	LED buck convertor switching node.
22	BST	Power	Boost voltage for top switch gate drive. Decouple to LDSW with a 100 nF capacitor.
23	LDGT	Output	LED buck convertor bottom switch gate driver.
24	PWM	Input	PWM Dimming input.
25	VLED	Input	LED string voltage measurement. Connect to GND when not used.
26	TLED	Input	LED string NTC resistor divider measurement point. Connect to GND when not used.
27	DIM	Analog	Analog Dimming input.
28	VREF	Analog	Reference precision voltage output. Decouple with a 2.2 μ F capacitor.
29	RTNA	Power	Application ground. Analog return.
30	CADC	Analog	ADC filter capacitor connection. Decouple to GNDA with a 10 nF capacitor.
31	ADDR1_CSB	Input	I ² C Address for I ² C mode. Tie to GND, VDDD or leave floating for alternative I ² C address. CSB in SPI mode.
32	SDA_MOSI	Input/Output	I ² C Data line. External pull-up resistor required. MOSI in SPI mode.
33	SCL_CLK	Input	I ² C Clock line. External pull-up resistor required. CLK in SPI mode.
34	INTB	Open Drain	I ² C Interrupt pin. External pull-up resistor required.
35	ADDR2_MISO	Input	I ² C Address. Tie to GND or leave floating for alternative I ² C address. MISO in SPI mode.
36	VDDD	Power	3V3 power input for the NCL31000 digital circuitry.
37	VDD1	Power	3V3 power output for the chip and external circuitry.
38	IVDD1	Input	Current measurement for VDD1 regulator. Connect to the positive terminal of the VDD1 sense resistor.
39	VDD1SW	Power	VDD1 buck convertor switching node.
40	GND	Power	Application ground. Ground connection for the VDD1 and VDD2 DC/DC convertors.
41	VBB	Power	Positive input power. Decouple to the GND with a 1 μ F capacitor. Connect to the positive terminal of the DC power supply.
42	VDD2SW	Power	VDD2 buck convertor switching node.
43	GND	Power	Application ground. Ground connection for the VDD1 and VDD2 DC/DC convertors
44	VDD2GB	Output	VDD2 buck convertor bottom switch gate driver.
45	P9V	Power	9 V gate drive voltage input. Decouple to GND with a 100 nF capacitor. Connect to P9V (pin 18) with a trace on the PCB.
46	VDD1GB	Output	VDD1 buck convertor bottom switch gate driver.
47	IVDD2	Input	Current measurement for VDD2 regulator. Connect to the positive terminal of the VDD2 sense resistor.
48	VDD2	Power	VDD2 power output for external circuitry.

NCL31000, NCL31001

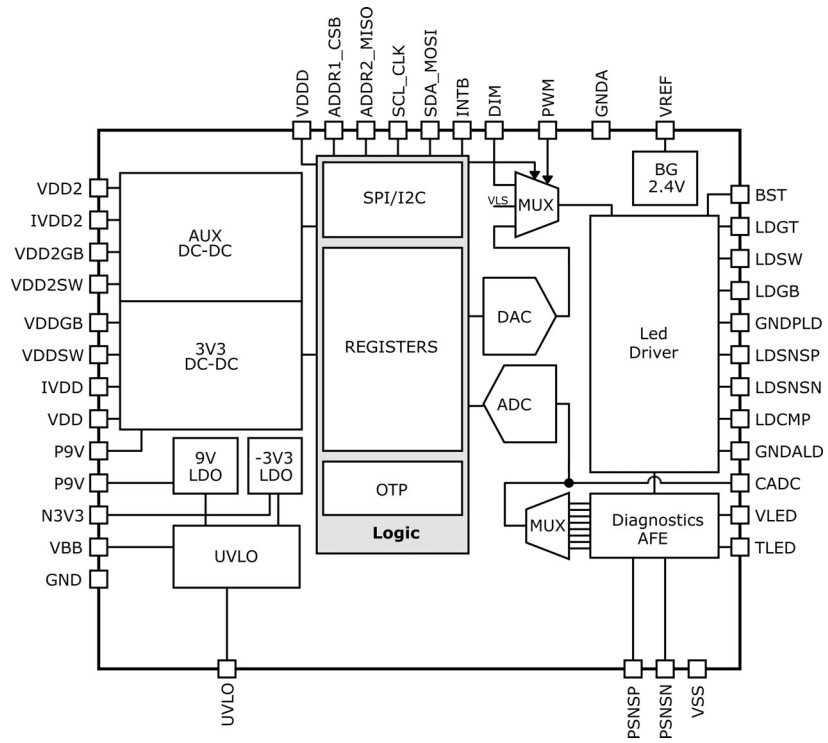

Figure 3. NCL31000 Block Diagram

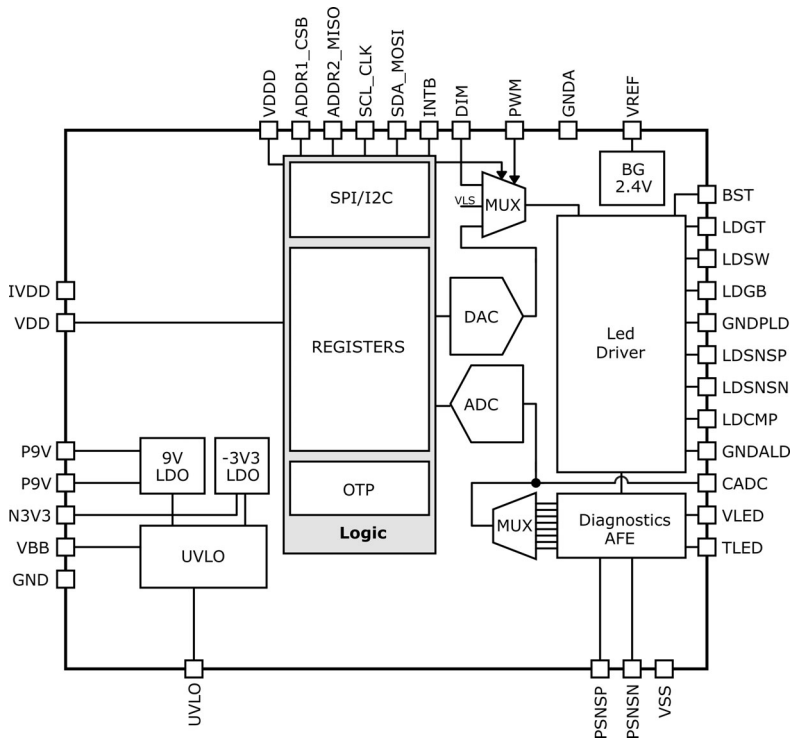

Figure 4. NCL31001 Block Diagram

NCL31000, NCL31001

ABSOLUTE MAXIMUM RATINGS

Symbol	Parameter	Min	Max	Unit			
VBB	Input Power Supply vs. VSS	-0.3	70	V			
GND, GNDPLD, GNDA, GNDALD	Application Ground vs. VSS	-0.3	VBB + 0.3	V			
BST	Analog Output vs. LDSW	-0.3	11	V			
LDGT	Analog Output vs. GND	-0.3	Min (70, VBB + 11)	V			
LDSW	Analog Output vs. GND	-0.3	VBB+0.3	V			
PSNSN, PSNSP	Analog Input vs. VSS	-0.3	3.6	V			
LDSNSN, LDSNSP	Analog Input vs. GND	-0.3	0.3				
VDD1	3.3 V Analog Supply vs. GND	-0.3	3.6	V			
VDDD	3.3 V Digital Supply vs. GND						
ADDR1_CSB	Digital Input/Output vs. GND						
ADDR2_MISO	Digital Input/Output vs. GND						
VREF	Analog Output vs. GND						
DIM	Analog Input vs. GND						
CADC	Analog Output vs. GND						
LDCOMP	Compensation Pin vs. GND						
IVDD1	Analog Input vs. GND				-0.3	Min (3.6, VDD1 + 0.3)	V
SDA_MOSI	Digital Input/Output vs. GND				-0.3	5.5	V
SCL_SCK	Digital Input vs. GND						
INTB	Open Drain Digital Output vs. GND						
P9V	Analog Output vs. GND	-0.3	11	V			
VDD1GB, VDD2GB	Analog Output vs. GND						
LDGB	Analog Output vs. GND						
N3V3	Analog Output vs. GND	VBB-3.6	VBB + 0.3	V			
VDD2	Analog Input vs. GND	-0.3	VBB + 0.3	V			
VLED	HV tolerant Input vs. GND						
PWM	HV tolerant Input vs. GND						
TLED	HV tolerant Input vs. GND						
IVDD2	Analog Input vs. GND						
VDD1SW	Analog Output vs. GND	-0.6	VBB + 11	V			
VDD2SW	Analog Output vs. GND						
T _{STRG}	Storage Temperature	-55	+150	°C			
T _J	Junction Temperature	-40	+125	°C			
ESD-HBM	Human Body Model; EIA-JESD-A114	2	-	kV			
ESD-CDM	Charged Device Model; ESD-STM5.3.1	500	-	V			

Stresses exceeding those listed in the Maximum Ratings table may damage the device. If any of these limits are exceeded, device functionality should not be assumed, damage may occur and reliability may be affected.

NCL31000, NCL31001

RECOMMENDED OPERATING CONDITIONS

Symbol	Parameter	Min	Max	Unit
V _{BB}	Input Power Supply (V _{BB} vs. V _{SS})	21.5	57	V
V _{I_D}	Digital Inputs SCL, SDA, INTB, PWM vs. GND	0	5	V
VTLED	Temperature Sense Analog Input vs. GND	0	VDD1	V
T _A	Ambient Temperature	-40	+85	°C
T _J	Junction Temperature	-40	+125	°C

Functional operation above the stresses listed in the Recommended Operating Ranges is not implied. Extended exposure to stresses beyond the Recommended Operating Ranges limits may affect device reliability.

THERMAL CHARACTERISTICS

Symbol	Characteristic	Value	Unit
θ _{JC}	Thermal Resistance, Junction-to-Case	38	°C/W
θ _{JA}	Thermal Resistance, Junction-to-Air	128	°C/W

1. θ_{JA} is obtained with 1S1P test board (1 signal – 1 plane) and natural convection. Refer to JEDEC JESD51 for details

ELECTRICAL CHARACTERISTICS

Symbol	Parameter	Condition	Min	Typ	Max	Unit
--------	-----------	-----------	-----	-----	-----	------

OSCILLATOR

OSC_FREQ	Oscillation Frequency		7.6	8	8.4	MHz
----------	-----------------------	--	-----	---	-----	-----

UNDER VOLTAGE LOCK-OUT CHARACTERISTICS

UVLO_H	V _{BB} UVLO Threshold Voltage (Note 2)	V _{BB} rising	1.15	1.23	1.3	V
UVLO_L	V _{BB} UVLO Threshold Voltage (Note 2)	V _{BB} falling	1.09	1.17	1.26	V
UVLO_hyst	UVLO Threshold Hysteresis		30	53	75	mV

CONSUMPTIONS (V_{BB} = 53 V)

I _{dd_on,0}	Operating Current	CTRL = 0; VDD1 Non-switching	–	2.03	–	mA
I _{dd_on,1}	Operating Current w. VDD2	CTRL = 1; VDD1, VDD2 Non-switching	–	2.12	–	mA
I _{dd_on,2}	Operating Current w. Metrology	CTRL = 4; VDD1 Non-switching	–	2.06	–	mA
I _{dd_on,3}	Operating Current w. VDD2 & Metrology	CTRL = 5; VDD1, VDD2 Non-switching	–	2.15	–	mA

VDD1 & VDD2 DCDC ELECTRICAL SPECIFICATIONS

VDD1x_Freq	Switching Frequency	JIT_EN = 0	126.6	133.3	140	kHz
N3V3	Internal V _{BB} -N3V3 Voltage	0 ≤ I ≤ 5 mA	3.13	3.3	3.47	V
P9V	Internal P9V Voltage (Generated in LED Block)	0 ≤ I ≤ 20 mA	8.55	9	9.45	V
VDD1xGB_Rpu	LS Gate Driver Pull-up Resistance		15	28	65	Ω
VDD1xGB_Rpd	LS Gate Driver Pull-down Resistance		2	3.25	6.5	Ω
VDD1xGB_Tr	LS Gate Driver Rise Time		10	20	52	ns
VDD1xGB_Tf	LS Gate Drive Fall Time		3	6	16	ns

VDD1 MAIN DCDC ELECTRICAL SPECIFICATIONS

DC3V3_VDD1	Main Supply Output Voltage		3.234	3.3	3.366	V
DC3V3_ILMT	Peak Inductor Current Limit	R _{sns} = 0.75 Ω	230	300	370	mA
VDD1_Ton,min	Minimum ON Time		50	110	200	ns
VDD1_Toff,min	Minimum OFF Time		50	88	200	ns
VDD1_HS_Ron	Top Switch on Resistance		1.5	3.3	7.5	Ω
I_VDDD	Operating Current on VDDD	CTRL = 0	–	3.15	–	mA

NCL31000, NCL31001

ELECTRICAL CHARACTERISTICS (continued)

Symbol	Parameter	Condition	Min	Typ	Max	Unit
VDD1 MAIN DCDC ELECTRICAL SPECIFICATIONS						
VDD1_ACRp	Equivalent AC Parallel Resistance	$R_{Sns} = 0.75 \Omega$; CCM	–	0.6	–	Ω
VDD1_ACLp	Equivalent AC Parallel Inductance	$R_{Sns} = 0.75 \Omega$; CCM	–	149	–	μH
VDDD RESET ELECTRICAL SPECIFICATIONS						
VDD1_POR_LH	VDD1(D) Reset Threshold H	VDD1(D) Rising	2.8	2.9	3.05	V
VDD1_POR_HL	VDD1(D) Reset Threshold L	VDD1(D) Falling	2.5	2.7	2.8	V
VDD1_POR_HY	VDD1(D) Reset Hysteresis		0.2	0.3	0.4	V
VDD2 AUXILIARY DCDC ELECTRICAL SPECIFICATIONS						
DCAUX_VDD2	Aux Supply Output Voltage	5V0 (VDD2_SEL = 2)	4.9	5	5.1	V
		7V2 (VDD2_SEL = 6)	7.056	7.2	7.344	V
		2V5 (VDD2_SEL = 0)	2.45	2.5	2.55	V
		3V3 (VDD2_SEL = 4)	3.234	3.3	3.366	V
		10V (VDD2_SEL = 1)	9.8	10	10.2	V
		12V (VDD2_SEL = 5)	11.76	12	12.24	V
		15V (VDD2_SEL = 3)	14.7	15	15.3	V
		24V (VDD2_SEL = 7)	23.52	24	24.48	V
DCAUX_ILMT	Peak Inductor Current Limit	5V0; $R_{Sns} = 0.22 \Omega$	882	948	1014	mA
		7V2; $R_{Sns} = 0.22 \Omega$	601	668	750	mA
		2V5; $R_{Sns} = 0.20 \Omega$	811	872	933	mA
		3V3; $R_{Sns} = 0.20 \Omega$	802	862	922	mA
		10V; $R_{Sns} = 0.33 \Omega$	544	604	664	mA
		12V; $R_{Sns} = 0.33 \Omega$	544	604	664	mA
		15V; $R_{Sns} = 0.33 \Omega$	538	598	678	mA
		24V; $R_{Sns} = 0.36 \Omega$	450	547	650	mA
VDD2_Ton,min	Minimum ON Time		50	87	150	ns
VDD2_Toff,min	Minimum OFF Time		50	84	150	ns
VDD2_HS_Ron	Top Switch on Resistance		0.5	1.1	2.65	Ω
VDD2_Sx	Slope Compensation	15V; $R_{Sns} = 0.33 \Omega$	–	0.073	–	A/ μs
		24V; $R_{Sns} = 0.36 \Omega$	0.028	0.067	–	A/ μs
VDD2_ACRp	Equivalent AC Parallel Resistance	5V0; $R_{Sns} = 0.22 \Omega$; CCM	–	0.23	–	Ω
		7V2; $R_{Sns} = 0.22 \Omega$; CCM	–	0.53	–	Ω
		2V5; $R_{Sns} = 0.20 \Omega$; CCM	–	0.12	–	Ω
		3V3; $R_{Sns} = 0.20 \Omega$; CCM	–	0.15	–	Ω
		10V; $R_{Sns} = 0.33 \Omega$; CCM	–	1.22	–	Ω
		12V; $R_{Sns} = 0.33 \Omega$; CCM	–	1.16	–	Ω
		15V; $R_{Sns} = 0.33 \Omega$; CCM	–	0.92	–	Ω
		24V; $R_{Sns} = 0.36 \Omega$; CCM	–	2.09	–	Ω

NCL31000, NCL31001

ELECTRICAL CHARACTERISTICS (continued)

Symbol	Parameter	Condition	Min	Typ	Max	Unit
--------	-----------	-----------	-----	-----	-----	------

VDD2 AUXILIARY DCDC ELECTRICAL SPECIFICATIONS

VDD2_ACLp	Equivalent AC Parallel Inductance	5V0; R _{SNS} = 0.22 Ω; CCM	–	60	–	μH
		7V2; R _{SNS} = 0.22 Ω; CCM	–	120	–	μH
		2V5; R _{SNS} = 0.20 Ω; CCM	–	29	–	μH
		3V3; R _{SNS} = 0.20 Ω; CCM	–	38	–	μH
		10V; R _{SNS} = 0.33 Ω; CCM	–	275	–	μH
		12V; R _{SNS} = 0.33 Ω; CCM	–	275	–	μH
		15V; R _{SNS} = 0.33 Ω; CCM	–	229	–	μH
		24V; R _{SNS} = 0.36 Ω; CCM	–	514	–	μH

LED DRIVER ELECTRICAL SPECIFICATIONS

VBB	Input Voltage Range for Stable Output	21.5	–	57	V
VLED	LED String Voltage vs. GND	4	–	38	V
VDIM	Analog DIM Input vs. GND	0	–	2.4	V
ILED (Note 4)	LED Current Range	0	–	3	A
VSNS (Note 5)	Sense Resistor Voltage	–0.24	–	0.3	V
VCSA_0 (Note 6)	Sense Amplifier Output Voltage [Inputs Shorted]	197	200	205	mV
ILED_OFFS (Note 7)	LED Current Regulation Offset Error Relative to VREF	–0.125	–	0.2	%
ILED_GAIN (Note 8)	LED Current Regulation Gain Error	–2	–	2	%

FAST CURRENT-MODE AMPLIFIER

LED_CSNSF_GAIN	Current-mode Loop Amplifier Gain	2.97	3.0	3.03	
----------------	----------------------------------	------	-----	------	--

LED DRIVER SAWTOOTH SLOPE COMPENSATION ELECTRICAL SPECIFICATIONS

SLP1_1	Slope Compensation 1 with SLP1<1:0> = 00	0.07	0.1	0.13	V/μs
SLP1_2	Slope Compensation 1 with SLP1<1:0> = 01	0.14	0.2	0.26	V/μs
SLP1_3	Slope Compensation 1 with SLP1<1:0> = 10	0.21	0.3	0.39	V/μs
SLP1_4	Slope Compensation 1 with SLP1<1:0> = 11	0.28	0.4	0.52	V/μs
SLP2_1	Slope Compensation 2 with SLP2<1:0> = 00	0.21	0.3	0.39	V/μs
SLP2_2	Slope Compensation 2 with SLP2<1:0> = 01	0.28	0.4	0.52	V/μs
SLP2_3	Slope Compensation 2 with SLP2<1:0> = 10	0.42	0.6	0.78	V/μs
SLP2_4	Slope Compensation 2 with SLP2<1:0> = 11	0.63	0.9	1.17	V/μs

LED DRIVER INTERNAL DAC ELECTRICAL SPECIFICATIONS

DIM_DNL	Internal DIM Differential Nonlinearity	–0.5	0	0.5	LSB
DIM_INL	Internal DIM Integral Nonlinearity	–0.5	0	0.5	LSB
DIM_MAX	Internal DIM Maximum (Code 0x7F)	2.376	2.4	2.424	V
DIM_MIN	Internal DIM Minimum (Code 0x09)	168.75	187.5	206.75	mV
DIM_RES	Internal DIM DAC Resolution	–	7	–	LSB

LED DRIVER OVER-CURRENT PROTECTION ELECTRICAL SPECIFICATION

OCP_VTH_UP	Comparator Threshold	2.95	3	3.04	V
------------	----------------------	------	---	------	---

LED DRIVER SOFT-START /OTA/NON-OVERLAPPING ELECTRICAL SPECIFICATION

GM	Error Amplifier Transconductance gm in Operational Mode	0.5	1	1.5	mS
GM_SST	Error Amplifier Transconductance gm in Soft Start Mode	60	100	180	μS

NCL31000, NCL31001

ELECTRICAL CHARACTERISTICS (continued)

Symbol	Parameter	Condition	Min	Typ	Max	Unit
--------	-----------	-----------	-----	-----	-----	------

LED DRIVER SOFT-START /OTA/NON-OVERLAPPING ELECTRICAL SPECIFICATION

TON_MIN	Minimum ON Time of the HS Driver		20	63	150	ns
TOFF_MIN	Minimum ON Time of the LS Driver		20	73	150	ns
TNOV	Non-overlapping Time		10	25	50	ns

REFERENCE VOLTAGE CHARACTERISTICS

VREF	Voltage Reference for DIAG/LED/DCDC [IREF < 2 mA]		2.394	2.4	2.406	V
IREF	Voltage Reference Current Consumption		-	-	3	mA

I²C TIMING CHARACTERISTICS (NCL31000I)

f_SCL	Interface Clock Frequency		-	-	400	kHz
-------	---------------------------	--	---	---	-----	-----

SPI TIMING CHARACTERISTICS (NCL31000S)

f_SCLK	Interface Clock Frequency		-	-	2	MHz
--------	---------------------------	--	---	---	---	-----

DIAGNOSTICS ELECTRICAL SPECIFICATION

DIAG_ILED	LED Current Measurement Overall Accuracy		-0.6	-	0.6	%
DIAG_VLED	LED Voltage Measurement Overall Accuracy		-0.8	-	0.8	%
DIAG_IBB	Input Current Measurement Overall Accuracy		-1	-	1	%
DIAG_VBB	Input Voltage Measurement Accuracy		-0.9	-	0.9	%
DIAG_IVDD1	VDD1 Current Measurement Overall Accuracy		-2	-	2	%
DIAG_IVDD2	VDD2 Current Measurement Overall Accuracy		-2	-	2	%
DIAG_VDD1	VDD1 Voltage Measurement Overall Accuracy		-1	-	1	%
DIAG_VDD2	VDD2 Voltage Measurement Overall Accuracy		-1	-	1	%
DIAG_TLED	TLED Voltage Measurement Overall Accuracy		-1	-	1	%
DIAG_CONSO	DIAG Current Consumption		-	-	200	μA

THERMAL PROTECTION CHARACTERISTICS

TSD_H	Thermal Shutdown, High Threshold		141	150	159	°C
TSD_L	Thermal Shutdown, Low Threshold		126	135	143	°C
TWRN_H	Thermal Warning, High Threshold		112	120	127	°C
TWRN_L	Thermal Warning, Low Threshold		101	108	114	°C

Product parametric performance is indicated in the Electrical Characteristics for the listed test conditions, unless otherwise noted. Product performance may not be indicated by the Electrical Characteristics if operated under different conditions.

2. Voltage referenced to VSS

3. E.g. after overcurrent timeout

4. This range depends on the sense resistor RSNS.

5. Assume inductor current ripple included. This spec implies that the inductor current ripple size has an upper limit $VSNS_{min} > RSNS \times I_{ppmax} / 2$.

6. The VCSA voltage is the output of the LED sense amplifier and is the compare voltage for the DIM input. VCSA_0 is given with the inputs shorted. The VCSA_0 voltage is the threshold to get exactly zero current.

7. This deviation is the total offset in the loop. It is specified relative to the VREF typical. It is useful for calculating the maximum offset error when using a VREF based solution for accurate dimming to low currents. It is derived from VCSA_0:

$$a. I_{LED_OFFS_HIGH} = (VCSA_{0_HIGH} - VCSA_{0_TYP}) / VREF$$

8. This error is a dominant factor in the LED current regulation error at mid and high LED currents. It is specified relative to VREF typical. Assume RSNS = 100 mΩ and ideal.

NCL31000, NCL31001

SIMPLIFIED APPLICATION SCHEMATIC

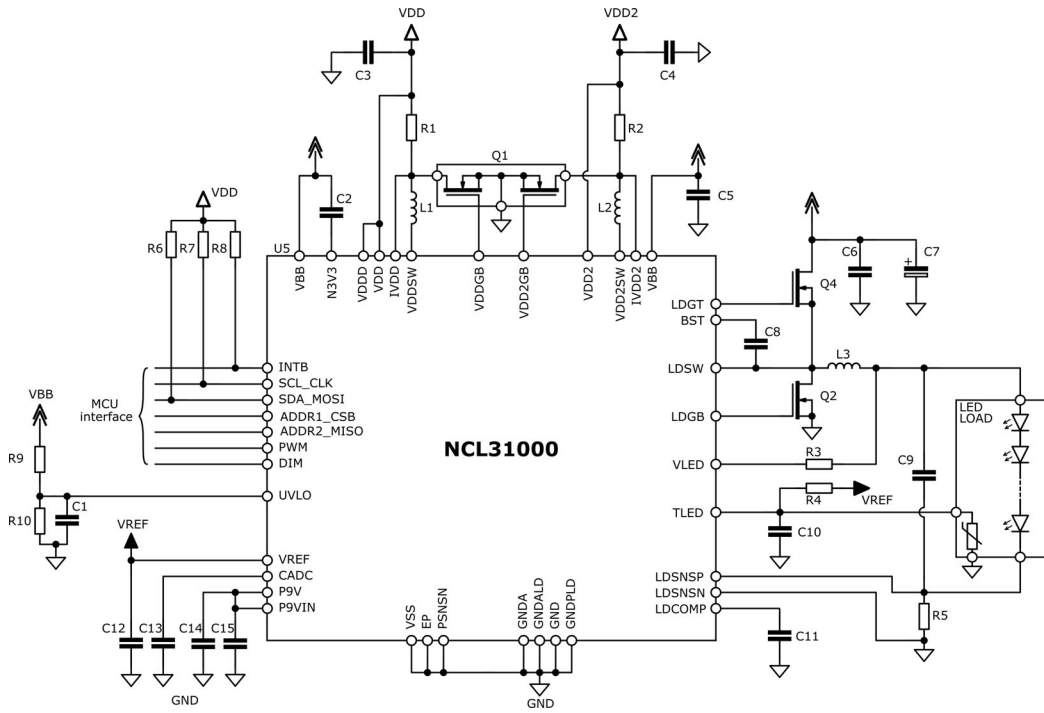

Figure 5. Typical Application Schematic

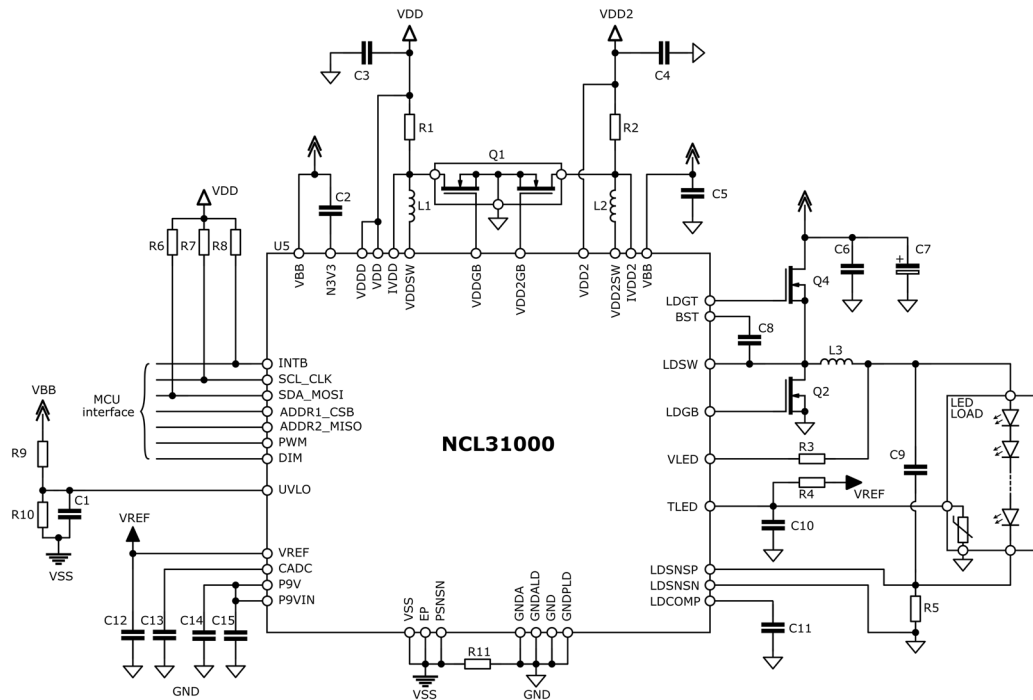

Figure 6. Typical Application Schematic with Input Current Sense

NCL31000, NCL31001

Table 1. TYPICAL BILL OF MATERIALS – BASED ON SINGLE CHANNEL WITH INPUT CURRENT SENSE

Symbol	Description	Value	Rating	Remark	Reference
C1	Decoupling	100 pF	10 V	(Note 9)	
C2	Decoupling, Buffer	1 μ F	10 V		
C3	Output Capacitor for VDD1	22 μ F	6.3 V		C1206C226K9PAC
C4	Output Capacitor for VDD2	47 μ F	6.3 V	(Note 11)	C1210C476M9PAC
C5	Fast Filter Capacitor for DC–DC's and Chip	1 μ F	100 V		C1210C105K1RAC
C6	Fast Filter Capacitor for LED Driver	2 x 1 μ F	100 V		C1210C105K1RACTU
C7	Buffer Capacitor for Application	56 μ F	80 V		A759MS566M1KAAE045
C8	LED Bootstrap Capacitor	100 nF	25 V		
C9	LED Driver Output Capacitors	2 x 470 nF	100 V		C0805C471K1RACTU
C13	Filtering TLED	100 nF	25 V		
C11	LED Driver Compensation Capacitor	10 nF	25 V		
C12	Stabilization Capacitor, Buffer VREF	2.2 μ F	10 V		
C13	Sample and Hold for ADC	10 nF	25 V		
C14	Decoupling, Buffer P9V	1 μ F	25 V		
C15	Decoupling P9V	100 nF	25 V		
R1	VDD1 Sense Resistor	750 m Ω			RCWE0603R750FKEA
R2	VDD2 Sense Resistor	200 m Ω		(Note 11)	RL1220S–R20–F
R3	Protection Resistor for Overvoltage on VLED Node	100 Ω			RC0603FR–07100RL
R4	TLED Resistor	10 k Ω 1%			
R5	LED Driver Current Sense Resistor	180 m Ω 1%	2 W	(Note 10)	
R6	I ² C Pull–up	4.7 k Ω			
R7	I ² C Pull–up	4.7 k Ω			
R8	Interrupt Pull–up	4.7 k Ω			
R9	UVLO (POR @ 35 V)	470 k Ω 1%			
R10	UVLO (POR @ 35 V)	16 k Ω 1%			
R11	Sense Resistor for Input Current	100 m Ω 1%	2 W		CRA2512–FZ–R100ELF
L1	VDD1 Buck Inductor	390 μ H			744777239
L2	VDD2 Buck Inductor	100 μ H			7447714101
L3	LED Driver Buck Inductor	68 μ H	2 A _{rms}	(Note 10)	
Q1	Dual NMOS Bottom Switching Transistor for DC/DCs				FDC8602
Q3	NMOS Bottom Switching Transistor for LED Driver				FDMA037N08L
Q4	NMOS Top Switching Transistor for LED Driver				NVTFS6H880N
U5					NCL31000

9. Must be smaller than 1 nF.

10. Inductor saturation current and LED current sense resistor depend on the application specifications such as required power, allowed current ripple. See LED driver section for details.

11. The values for L2, R2 and C4 in the table are specific for the 5 V VDD2 output. Refer to table 6 and 10 for other VDD2 output voltages.

General: The schematic does not show EMI filtering required for some applications.

DUAL STEP-DOWN CONVERTER FUNCTIONAL DESCRIPTION

The NCL31000 incorporates a dual synchronous step-down switching converter for generating two voltage rails. The top mosfets are internal in NCL31000, whereas the bottom mosfets need to be added externally.

The regulators employ a constant-frequency peak current-mode control scheme with internal compensation. The inductor current is sensed through a resistance in series with the inductor. This also allows the NCL31000 to measure the average output current (see Metrology section). Depending on the load current, the converter operates in Discontinuous Conduction Mode (DCM) or Continuous Conduction Mode (CCM).

The VDD1 regulator, which is automatically enabled when the voltage on the UVLO pin rises above the UVLO_H threshold, generates a 3.3 V output voltage with 150 mA output current capability to power the system microcontroller (next to some internal logic on VDDD).

The VDD2 regulator needs to be enabled through the digital interface. The default output voltage of VDD2 is 5 V (with 510 mA output current capability), but other output voltages (and corresponding other output current capabilities) can be programmed by the digital interface: 2.5 V, 3.3 V, 7.2 V, 10 V, 12 V, 15 V or 24 V.

Bottom Mosfet

The bottom mosfets should have the appropriate drain-source on-resistance and voltage rating (≥ 80 V) while maintaining low output capacitance, low gate charge and good drain-source diode characteristics (reverse recovery). Preferably, the package(s) should be very small to enable a compact PCB layout as well.

Based on above considerations, it is obvious that dual n-channel mosfet FDC8602 seems to be – by far – the best choice to complement NCL31010.

Table 2. DUAL N-CHANNEL MOSFET

Product	V _{DS} (V)	r _{DS(on)} (mΩ)	Package Type
FDC8602	100	350	TSOT-23-6

Switching Frequency

The switching frequency of the NCL31000 DC/DC regulators is 133.3 kHz. This switching frequency is derived from the internal accurate 8 MHz master clock which is divided by 60.

In terms of efficiency and EMI, this low switching frequency is beneficial and yet it allows a small overall solution size (small external inductors and capacitors).

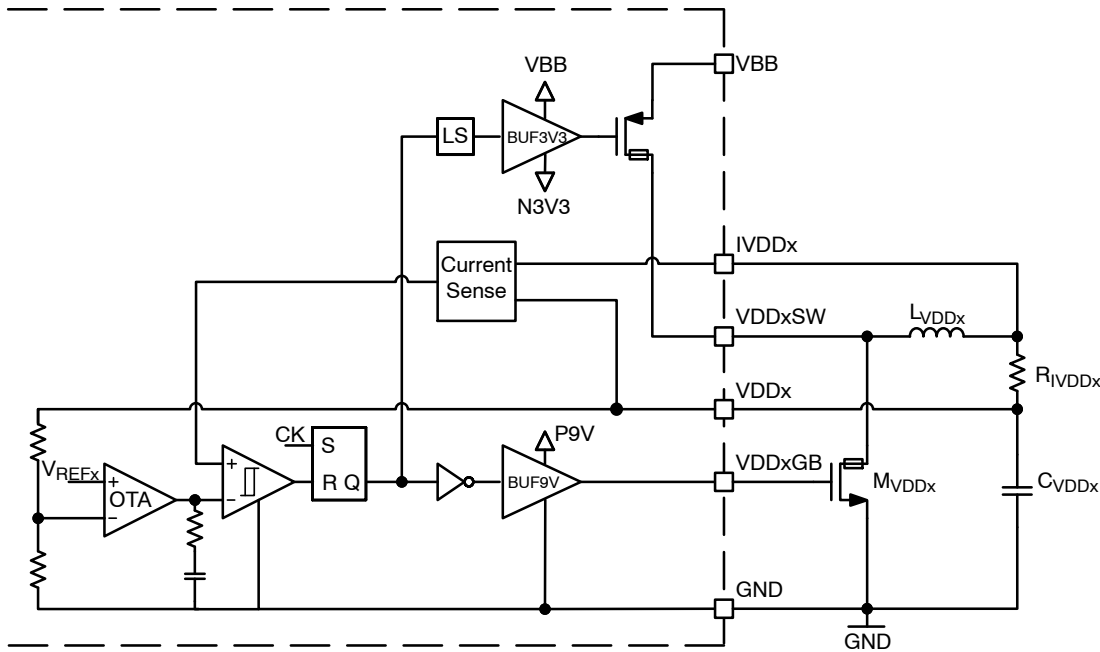

Figure 8. DCDC Block Diagram

Current Sense Resistor and Peak Current Limit

The inductor current is sensed by a current sense resistor in series with the inductor. The sense resistor value configures the gain of the sensed current signal that is compared to the control voltage to determine when the top mosfet needs to be switched off to maintain regulation. The sense resistor value also configures the peak inductor current limit at which the top mosfet will be switched off – despite a higher control voltage – in order to protect the power stage of the converter against overcurrents.

For the VDD1 regulator, a 750 mΩ sense resistor is recommended.

For the VDD2 regulator with 5 V output voltage, a 200 mΩ sense resistor is recommended. For the other output voltages, the recommended sense resistor value can be found in table 6.

The current sense resistors should have a 1% tolerance.

Inductor

The inductor saturation current should be higher than the maximum peak switch current of the converter. Within an inductor series, smaller inductance values have a higher saturation current rating. Allowing a larger than typically recommended inductor ripple current enables the use of a physically smaller inductor.

For the VDD1 regulator, a Würth WE–PD Size 7345 Inductor with 390 μH Inductance is recommended.

Table 3. INDUCTOR FOR VDD1

Product	L (μH)	R _{DC} typ. max. (Ω)	I _{SAT} typ. (A)
744777239	390 ±20%	1.25 2.85	0.42

For the VDD2 regulator with 5 V output voltage, the Würth WE–PD Size 1050 P Inductor with 100 μH Inductance is recommended. For the other output voltages, the recommended inductance value from the same inductor series can be found in table 6.

Table 4. INDUCTORS FOR VDD2

Product	L (μH)	R _{DC} typ. max. (mΩ)	I _{SAT} typ. (A)
7447714101	100 ±20%	165 198	1.8
7447714331	330 ±20%	655 750	1
7447714471	470 ±20%	960 1100	0.82

Maximum Output Current

The maximum load current that will be available is the peak inductor current limit minus half the peak-to-peak inductor ripple current:

$$I_{OUT} = I_{LIM} - \frac{(V_{IN} - V_{OUT}) \times V_{OUT}}{2 \times L \times V_{IN} \times f_{SW}} \quad (\text{eq. 1})$$

To determine the maximum guaranteed output current above equation should be evaluated with the minimum value of the peak inductor current limit I_{LIM} , of the inductance L (tolerance and saturation) and of the switching frequency f_{sw} . For both the VDD1 regulator and all output voltages of the VDD2 regulator, conversely, the maximum value of the input voltage V_{IN} (i.e. 57 V) should be used here. Likewise for the output voltage V_{OUT} in above equation an equivalent value $V_{OUT,eq}$ can be used here to incorporate the slight increase in duty cycle with the output current due to the (maximum) resistance of the (bottom) mosfet, the inductor and the sense resistor:

$$V_{OUT,eq}(I_{OUT}) = V_{OUT,typ} + (r_{DS(on)} + R_{DC} + R_{CS}) \times I_{OUT} \quad (\text{eq. 2})$$

Based on above considerations, the output current capability of both converters operated with the recommended current sense resistance, inductor and bottom mosfet is given below in table 5 and table 6.

Table 5. VDD1 CONFIGURATION

V _{OUT} (V)	I _{OUT} (mA)	R _{CS} (mΩ)	L (μH)
3.3	150	750	390

Table 6. VDD2 CONFIGURATION

V _{OUT} (V)	I _{OUT} (mA)	R _{CS} (mΩ)	L (μH)
2.5	560	220	100
3.3	515		
5	510	200	330
7.2	415		
10	335	330	330
12	315		
15	285		
24	230	390	470

The listed output current capability still contains some headroom for a temporarily higher output current after a load step-up transient (in order not to influence the load transient response settling time) and for the variation of the switching frequency due to spread spectrum modulation.

Output Capacitor Selection

The VDD1 and VDD2 regulators do not require any series resistance (ESR) in the output capacitor. Therefore ceramic capacitors with X5R or X7R dielectric are recommended. Unfortunately for these capacitors it is usually not sufficient to only look at the nominal capacitance value: one should always check the Capacitance versus Bias Voltage chart to know the actual remaining capacitance with the output voltage applied!

Some recommended capacitors from the Kemet SMD X5R and X7R series are listed in table 7 (Size 1206) and table 8 (Size 1210).

Table 7. X5R CAPACITORS SIZE 1206

Product	C ₀ (μF)	V _{Rated} (V)	C _{VDD2} (μF @ V)
C1206C226K9PAC C1206C226M9PAC	22 ±10% 22 ±20%	6.3	20.3 @ 2.5
			19 @ 3.3
			14.1 @ 5.0
C1206C106K4PAC	10 ±10%	16	9.9 @ 2.5
			9.8 @ 3.3
			9.5 @ 5.0
			9 @ 7.2
			8 @ 10
C1206C106K3PAC	10 ±10%	25	5.3 @ 15
C1206C475K5PAC	4.7 ±10%	50	3.1 @ 24

Table 8. X5R AND X7R CAPACITORS SIZE 1210

Product	C ₀ (μF)	V _{Rated} (V)	C _{VDD2} (μF @ V)
C1210C107M9PAC	100 ±20%	6.3	79.8 @ 2.5
			60.7 @ 3.3
C1210C476M9PAC	47 ±20%	6.3	42.2 @ 5.0
C1210C226K8PAC	22 ±10%	10	17.1 @ 7.2
C1210C106K4PAC	10 ±10%	16	8 @ 10
C1210C106K3RAC	10 ±10%	25	6.7 @ 15
C1210C106M6PAC	10 ±20%	35	9.1 @ 10
			8.7 @ 12
			8 @ 15
			5 @ 24

For X5R and X7R dielectric capacitors the change in capacitance over their operating temperature range is limited to ±15%.

The output capacitor is needed to stabilize the control loop. The gain crossover frequency of the complex open loop gain can be estimated by:

$$f_{gc} \approx \frac{1}{2 \times \pi \times ACR_p \times C_{VDDx}} \quad (\text{eq. 3})$$

This gain crossover frequency should be significantly lower than half the switching frequency. This places a constraint on the minimum output capacitance value.

The recommended output capacitors for the VDD1 regulator are listed in Table 9.

Table 9. CAPACITOR(S) FOR VDD1

V _{OUT} (V)	C _{VDD} Component(s)	C _{VDD1} (μF)
3.3	22 μF / 6.3 V / 1206	19
	2 x 10 μF / 16 V / 1206	19.6

The minimum output capacitor values for the VDD2 regulator are listed in Table 10 and those listed in bold are recommended.

Table 10. CAPACITOR(S) FOR VDD2

V _{OUT} (V)	C _{VDD} Component(s)	C _{VDD2} (μF)
2.5	100μF / 6.3V / 1210	79.8
	100 μF / 6.3 V / 1210 + 22 μF / 6.3 V / 1206	100.1
3.3	100 μF / 6.3 V / 1210	60.7
	100 μF / 6.3 V / 1210 + 22 μF / 6.3 V / 1206	79.7
5	47 μF / 6.3 V / 1210	42.2
	47 μF / 6.3 V / 1210 + 10 μF / 16 V / 1206	51.7
	47 μF / 6.3 V / 1210 + 22 μF / 6.3 V / 1206	56.3
7.2	22 μF / 10 V / 1210	17.1
	2 x 10 μF / 16 V / 1206	18
	22 μF / 10 V / 1210 + 10 μF / 16 V / 1206	26.1
	3 x 10 μF / 16 V / 1206	27
10	10 μF / 35 V / 1210	9.1
	2 x 10 μF / 16 V / 1206	16
12	10 μF / 35 V / 1210	8.7
	2 x 10 μF / 16 V / 1206	13.4
15	10 μF / 35 V / 1210	8
	2 x 10 μF / 25 V / 1206	10.6
	2 x 10 μF / 25 V / 1210	13.4
	3 x 10 μF / 25 V / 1206	15.9
	10 μF / 35 V / 1210	5
24	10 μF / 35 V / 1210	5
	2 x 4.7 μF / 50 V / 1206	6.2

Transient Response

A first order equivalent circuit of the output impedance of the NCL31000 DC/DC regulators operating in CCM is shown in figure 9.

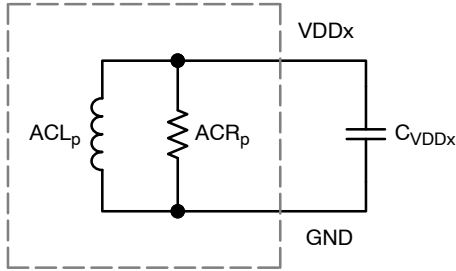

Figure 9. Model for Loop Response

The output capacitor delivers the initial current for transient loads. The output voltage undershoot/overshoot after a load step up/down transient can be estimated by:

$$\Delta V_{VDDx} = -ACR_p \times \Delta i_{VDDx} \quad (\text{eq. 4})$$

On the other hand, the model explains there is a constraint on the maximum output capacitance value. This can be expressed by the damping factor of the parallel RLC circuit:

$$\xi = \frac{1}{2 \times ACR_p} \times \sqrt{\frac{ACL_p}{C_{VDDx}}} \quad (\text{eq. 5})$$

It is best to keep the damping factor at or above unity. That it is equivalent to keeping the gain crossover frequency at least 4 times higher than the compensation network zero:

$$f_z = \frac{ACR_p}{2 \times \pi \times ACL_p} \quad (\text{eq. 6})$$

Otherwise the load step response will become oscillatory.

Input Voltage Range

The minimum input voltage is determined by the NCL31000 VBB undervoltage lockout (UVLO). With appropriate filtering, both the VDD1 and the VDD2 regulators shall continue to operate without interruption in the presence of transients on the DC power supply.

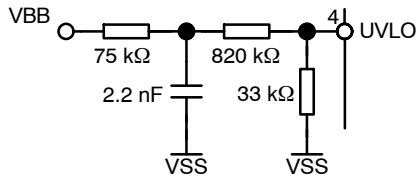

Figure 10. UVLO Filter

Eventually another constraint on the minimum input voltage is related to the subharmonic oscillation phenomenon that might occur in current-mode controlled converters. A rule of thumb is to operate a peak

current-mode controller without compensation ramp in CCM up to 33.5% duty cycle in order to keep the Q_p of the current-mode double pole up to 1.932 ($\xi_p \geq 0.259$). For a peak current-mode controller with compensation ramp in CCM, this rule of thumb for the duty cycle becomes:

$$D \leq \frac{0.335}{\left(1 - \frac{L \times S_x}{V_{OUT}}\right)} \quad (\text{eq. 7})$$

This duty cycle requirement in CCM can be translated into a minimum input voltage requirement:

$$V_{IN} \geq 2.985 \times (V_{OUT} - L \times S_x) \quad (\text{eq. 8})$$

Obviously without compensation ramp this equation simplifies to:

$$V_{IN} \geq 2.985 \times V_{OUT} \quad (\text{eq. 9})$$

Above constraint explains why a compensation ramp is implemented on the VDD2 regulator for the 15 V and 24 V output voltage settings. Likewise it explains why there is no need for a compensation ramp on the VDD1 regulator and on the VDD2 regulator for the other output voltage settings with an input voltage above 35 V.

The maximum input voltage is determined by the maximum recommended operating voltage of the VBBP pins (i.e. 57 V).

Input Capacitor

The VBB pin 41 must be decoupled to the source of the bottom mosfets (FDC8602) with a ceramic capacitor. The Kemet X7R Size 1210 Capacitor with 1 μ F nominal capacitance value is a good option, since the capacitance change over DC bias voltage remains moderate.

Table 11. X7R CAPACITOR SIZE 1210

Product	C ₀ (μ F)	V _{Rated} (V)	C _{VPORTP} (nF @ V)
C1210C105K1RAC	1 \pm 10%	100	865 @ 41.1
			800 @ 50
			702 @ 57

Light Load Operation

In Discontinuous Conduction Mode (DCM), the square of the top mosfet on-time is proportional to the output current. When the load becomes lower than the output current corresponding with the minimum on-time, the converter will exhibit pulse skipping behavior.

VDD2 Output voltage

The VDD2 output voltage is programmed in the VDD2_SEL[2:0] bits of Test Register 10 (&TREG10 0x6E):

NCL31000, NCL31001

Table 12.

Bit [2:0]	VDD2 Output Voltage (V)
000b	2.5
001b	10
010b	5
011b	15
100b	3.3
101b	12
110b	7.2
111b	24

The default output voltage of VDD2 is 5 V.

Do NOT write to Test Register 10 when the VDD2 regulator is already enabled.

VDD2 Enable and Shutdown

The VDD2 regulator is enabled when the VDD2_EN bit in the Control Register (&CTRL 0x04) is set.

Table 13.

Bit 0	VDD2EN
0b	Disable VDD2
1b	Enable VDD2

Soft-Start

Both regulators have soft-start implemented in order to limit the overshoot during start-up.

Short Circuit Protection

Besides the peak current limit, the NCL31000 contains additional short circuit protection. If the voltage drops significantly below the regulated value during around 15 ms, that specific converter will be shut down. The converter will be automatically restarted after a cool down period of around 120 ms.

Severe Faults

The NCL31000 monitors the drain-source voltage of a mosfet that is turned-on: if the voltage becomes too large due to excessive current flow through the mosfet, the respective converter will be latched off.

If this occurs on the VDD2 regulator, the VDD2NOK bit in the Status Positive Register (&STATP) will be set. This will generate an interrupt on the INTB pin if the VDD2NOK bit in the Interrupt Positive Mask Register (&INTP) was not masked.

LED DRIVER FUNCTIONAL DESCRIPTION

The NCL31000 incorporates a peak current-mode buck LED controller. The controller operates only in CCM mode and is designed to drive high power LED loads up to 90 W and beyond. A block diagram of the concept with the essential parts is given in figure 11.

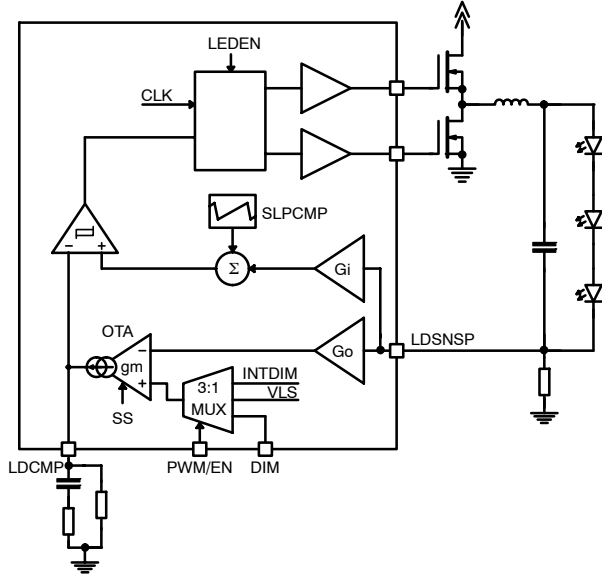

Figure 11. LED Driver Block Diagram

The LED driver is enabled when the LEDEN bit in the CTRL register is set. When the LED driver is enabled it is switching and regulates a current controlled by the DIMCTRL voltage shown in figure 11. The relationship between DIMCTRL and the LED current is given below.

$$I_{LED} = \frac{(VDIMCTRL - V_{CSA_0})}{R_{SNS} \times 7.333} \quad (\text{eq. 10})$$

Several sources can be multiplexed to the DIMCTRL signal, see figure 12.

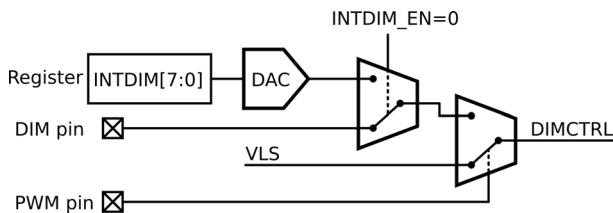

Figure 12. DIM Selection

The analog DIM input gives the best dimming performance in terms of linearity, bandwidth and accuracy.

The DIM pin threshold voltage that provides exactly zero current is the VCSA_0 voltage. Applying a voltage below the VCSA_0 lower limit guarantees zero current.

The PWM pin can be used for PWM dimming. A PWM signal on the PWM input can be used to switch the LED

current between zero and the level defined by the voltage level on the DIM pin. The duty-cycle of this signal will define the average LED current. To have a good linear relationship between the duty-cycle and the LED current the frequency of this signal must be below 1 – 2 kHz. This method provides a simple way to use PWM directly to control the LED current, however it does not give the best dimming accuracy and linearity and the duty-cycle range is limited. When the PWM digital input pin is low, the MUX connects VLS to DIMCTRL. VLS has a steady value just below VCSA_0 to guarantee that the LED driver is regulating zero current when PWM = 0. When the PWM pin is high, the voltage on the DIM pin is connected to DIMCTRL.

When the INTDIMEN bit in the INTDIM register is set the internal 7-bit DAC output is connected to DIMCTRL. In this case, the LED current will depend on the value programmed in the 7 bits of the INTDIM register. The relationship between the register value and the DAC output voltage is given below.

$$V_{INTDIM} = \frac{V_{REF} \times (INTDIM[7 : 0] + 1)}{128} \quad (\text{eq. 11})$$

The internal DAC can be useful when, for example, the host MCU is being re-flashed and the DIM voltage is not controlled during this period. In this case the MCU can instruct the internal DAC to take control of DIMCTRL net moments before the MCU firmware is under maintenance. This is called ‘Warm Boot’.

Voltage Reference

The NCL31000 provides a precise ($\pm 0.3\%$) 2.4 V reference voltage on the VREF pin, which can be used by external components, for example, as the reference of an external PWM to DIM circuit or a DAC that controls the DIM pin voltage. The load on this pin must be limited to 2 mA to ensure the accuracy of the voltage. The advantage of using this VREF is that the VREF voltage and the VCSA_0 voltage (the threshold point for zero current) are related. If VREF deviates, VCSA_0 will deviate in the same direction by a proportional factor, thus the LED current regulation inaccuracy of a circuit that is VREF based does not suffer from the VREF deviation.

Sense Resistor

Select an appropriate sense resistor based on the maximum LED current. The resistor value can be calculated according to:

$$R_s = \frac{(VREF - VCSA_0)}{7.333 \times I_{led_max}} \quad (\text{eq. 12})$$

Make sure to select a sense resistor that has a value between 50 mΩ and 300 mΩ. Consider the power rating and the accuracy. A 1 W or 2 W / 1% sense resistor is sufficient for most applications.

Buck Inductor

The rule of thumb is to choose the inductor so that the peak-peak current ripple in the inductor is 20..30% of the max dc-current. Calculate the required inductance according to:

$$L = \frac{V_i}{4 \times f_s \times I_{led_{max}} \times 0.3} \quad (\text{eq. 13})$$

Make sure that the specified RMS current rating of the inductor (typically the current that results in a temperature increase of 40°C due to copper losses) is at or above the max dc-current used in the application. The saturation current rating minus 20% derating should still be at or above the largest peak current. Use the formulas below to find appropriate minimum RMS current and saturation current values.

$$I_{rms} > I_{led_{max}} \quad (\text{eq. 14})$$

$$I_{r_{max-pkpk}} = \frac{V_{i_{max}}}{4 \times f_s \times L} \quad (\text{eq. 15})$$

$$I_{sat} > \left(I_{led_{max}} + \frac{I_{r_{max-pkpk}}}{2} \right) \times 1.2 \quad (\text{eq. 16})$$

Output Capacitor

The purpose of the output capacitor is to filter the high frequency inductor ripple current to some extent. This must be a 100 V rated ceramic capacitor(s) with low ESR. The required output capacitor depends on the switching frequency, the expected LED ripple current ($I_{r_{LED-pkpk}}$), the dynamic resistance of the LED string (R_d) and the inductor ripple current ($I_{r_{max-pkpk}}$). The expression is given below:

$$C_o = \frac{8}{\pi^2} \times \frac{I_{r_{max-pkpk}}}{2\pi \times f_s \times I_{r_{LED}} \times R_d} \quad (\text{eq. 17})$$

Substituting $I_{r_{max}}$ gives:

$$C_o = \frac{V_{i_{max}}}{31 \times f_s^2 \times L \times I_{r_{LED-pkpk}} \times R_d} \quad (\text{eq. 18})$$

A reasonable output capacitor value would be anything between 100 nF and 1 – 3 µF. Try to avoid 1608 (metric) packages or smaller to avoid audible noise. The output capacitance has no significant effect on stability.

Bandwidth & Stability

The control loop in this configuration exhibits no poles to be compensated in the bandwidth area so a single compensation capacitor connected to LDCMP pin will suffice. This strategy is suitable for a bandwidth up to 1/10th of the switching frequency and provides a phase margin of 60 – 75 degrees. The compensation capacitor can be calculated as:

$$C_c = 2.44 \times \frac{G_M}{2 \times \pi \times f_c} \quad (\text{eq. 19})$$

f_c is the wanted cross-over frequency and $G_M = 1 \text{ mS}$.

Slope Compensation

Since a peak-current-mode buck convertor is sensitive to sub-harmonic oscillations for duty-cycles above 33% slope compensation must be added. There is a minimum amount of slope needed to damp sub-harmonic oscillations within one switching cycle. The slope value can be programmed in the SLPCMP register. The default value is a good setting for most applications and normally no changes have to be made to this register. If the phase margin is not sufficient (<60 degrees), program ‘0’ to SLP1 and SLP2 field in the SLPCMP register.

The required amount of slope increases with output voltage and the ratio from output to input voltage (duty-cycle). A separate slope setting can be programmed for slopes below 50% duty-cycle (SLP1 field) and above (SLP2 field). The possibilities for SLP1 and SLP2 fields are presented in table 14 and 15 respectively. The default value for SLP1 and SLP2 is set to 0.1 V/µs and 0.3 V/µs. Increase SLP1 one level if sub-harmonic oscillation is seen below 50% duty-cycle. Increase SLP2 one level if subharmonic oscillation is seen above 50% duty-cycle.

Table 14. SLP1 VALUES

SLP1 Register Value	Slope [V/µs]
0	0.1
1	0.2
2	0.3
3	0.4

Table 15. SLP2 VALUES

SLP2 Register Value	Slope [V/µs]
0	0.3
1	0.4
2	0.6
3	0.9

Switching Frequency

All the clocks in the chip are derived from a main 8 MHz clock. The LED driver’s switching frequency can be programmed with the LEDFC register. The value in the register relates to the LED driver switching frequency clock according to table 16. The default switching frequency is 500 kHz. For most applications that regulate LED currents below 1.5 A, a switching frequency of 500 kHz is a good choice. For applications that regulate above 1.5 A, 400 kHz is recommended.

Table 16. SWITCHING FREQUENCY

LEDFC [5:0]	DIVISOR	LED_CLK [kHz]
0	8	1000.00
1	10	800.00
2	12	666.67
3	14	571.43
4	16	500.00
5	18	444.44
6	20	400.00
7	22	363.64
8	24	333.33
9	26	307.69
10	28	285.71
11	32	250.00
12	34	235.29
13	38	210.53
14	42	190.48
15	46	173.91
16	52	153.85
17	56	142.86
18	64	125.00
19	70	114.29
20	76	105.26
21	84	95.24
22	102	78.43
23	112	71.43
24	124	64.52
25	150	53.33
26	180	44.44

Switching Transistors

The selection of the switching transistors is a critical aspect for the correct functioning of the LED driver. It can significantly impact the power efficiency and thermal performance. The top fet in particular will dissipate most of the switching losses. Because this component is essential to the LED driver performance it is advised to select one of the validated transistors for top and bottom given in table 17. The transistors are ranked high–low for efficiency. The typical LED driver efficiency achievable with the proposed transistors for 30 – 70 W range is 97%. The best combination is to use FDMA037N08L as bottom fet and NVTFS6H880N or NVTFS6H888N as top fet.

Table 17. TRANSISTOR SELECTION

	Product	V _{DS} (V)	r _{DS(on)} (mΩ)
Top	NVTFS6H880N	80	32
	NVTFS6H888N	80	55
	NVTFS6H860N	80	21.1
Bottom	FDMA037N08LC	80	36.5

Do not use external gate resistors for the transistors. The chip uses the voltages at the gate nodes as feedback for desaturation protection and fast switching.

Thermal Considerations

Additional copper is needed for good thermal performance. A typical design with LED currents below 2 A (<60 W) requires a small (both copper sides) cooling plane with size 2 – 3 cm² connected to the drain of the top fet. For 2 A and above (>60 W), a 3 – 4 cm² copper plane is recommended on both sides. The bottom fet drain connection should also have a small 0.5 – 1 cm² copper plane.

Metrology

The NCL31000 incorporates a high accuracy metrology block that measures several voltages, currents and temperatures in the system. This is made possible by an internal 10–bit ADC, which is multiplexed to measure VBB, VDD11, VDD2, VLED, ILED, IBB, IVDD1, IVDD2 and TLED. The metrology measurements can be enabled with the DIAG_EN bit in the CTRL register. The measurements are referenced to GND and are sampled every 100 ms. The measurements can be read out from the 16–bit registers. The relationship between the measured voltage/current/temperature and the values read in the registers is given below.

$$VBB = VBB_{reg} \times \frac{5000}{201} \times \frac{VREF}{2^{16}} \tag{eq. 20}$$

$$IBB = IBB_{reg} \times \frac{VREF}{6 \times R_s \times 2^{16}} \tag{eq. 21}$$

$$VDD = VDD_{reg} \times \frac{3}{2} \times \frac{VREF}{2^{16}} \tag{eq. 22}$$

$$VDD2 = VDD2_{reg} \times \frac{30}{4} \times \frac{VREF}{2^{16}} \tag{eq. 23}$$

$$IDD = IDD_{reg} \times \frac{VREF}{10 \times R_s \times 2^{16}} \tag{eq. 24}$$

$$IDD2 = IDD2_{reg} \times \frac{VREF}{10 \times R_s \times 2^{16}} \tag{eq. 25}$$

$$VLED = VLED_{reg} \times \frac{35}{2} \times \frac{VREF}{2^{16}} \tag{eq. 26}$$

$$ILED = ILED_{reg} \times \frac{3}{22} \times \frac{VREF}{R_s \times 2^{16}} \tag{eq. 27}$$

$$TLED = TLED_{reg} \times \frac{33}{24} \times \frac{VREF}{2^{16}} \tag{eq. 28}$$

Status Bits

The NCL31000 has ten status-monitoring bits, spread over two 8-bit registers. The status bits are active when a particular condition is met. As an example, STAT1.TW is active when the internally measured temperature exceeds the temperature limit set by the TWTH (thermal warning threshold). When the condition disappears, the corresponding bit becomes inactive immediately. The actual, immediate, value of the status bits can be accessed through the read-only status registers (STAT). Status bits can become active only very briefly. As such, reading the STAT is not sufficient to detect the activation of a fault in an NCL31000 device: between subsequent reads, the fault could have appeared and disappeared. The read-only ‘Status Positive Transition’ register (STATP) addresses this problem. It reflects all status bits that have become active since the last read of the STATP. Thus, by reading STAT and STATP, the host microcontroller can determine whether a status bit has been active since the last read, and whether it is still active. The STATP bits are cleared on read. The addresses of the STAT and STATP are contiguous. Thus the microcontroller can read out the STAT and STATP atomically, ensuring coherent information is received.

In addition to STATP, the ‘Status negative transition’ STATN register activates when the fault disappears (negative edge STAT register). This register is also cleared on read. The status signals are grouped in two categories: warnings and errors. This is discussed below.

Warnings

Some of the status bits can be considered as a warning signal meaning there is no need for a very fast response from the NCL31000 itself and the decision can be left up to the microcontroller. The NCL31000 takes no action other than signal that a threshold is crossed using the status bits. The status bits that are considered as warnings are: TW, LEDTSD, LEDTW, LEDOV, LEDUV, VDD2OC, VDD1OC. These warnings are reflected in the STAT1 and STATP1/STATN1 registers. These analog values are measured by the metrology block with the internal ADC and a sampling rate of 100 ms. For the warnings, all the thresholds and hysteresis values are programmable except for TW. An example for LEDTW is given in figures 13 and 14.

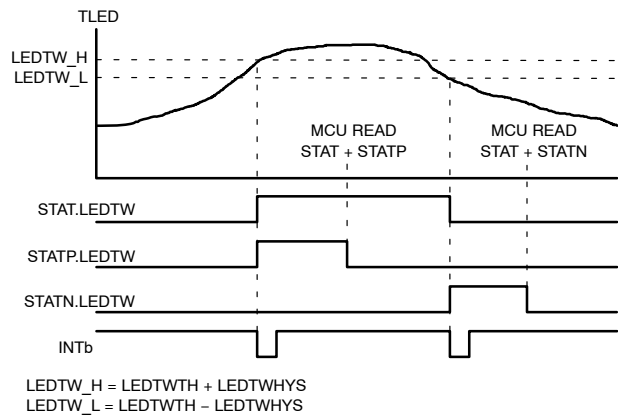

Figure 13. LEDTW [INTCFG=1 INTP/INTN=1]

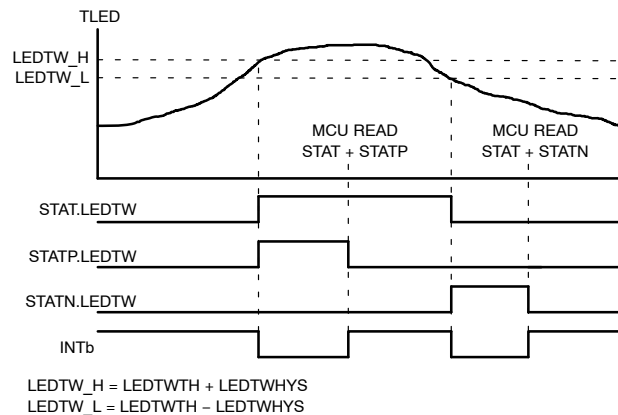

Figure 14. LEDTW [INTCFG=0 INTP/INTN=1]

A warning occurs when a programmable limit is crossed. For example, when the voltage on the TLED pin exceeds the $LEDTWTH + LEDTWHYS$ threshold the status LEDTW bit is set in the STAT register. The threshold and hysteresis are programmable in the LEDTWTH and LEDTWHYS registers. Only when the voltage on the TLED pin drops below $LEDTWTH - LEDTWHYS$ the LEDTW bit in the STAT is cleared. If the LEDTW bit in the Interrupt Mask register is set a pulse interrupt will be given on the INTb pin when the LEDTW bit is set in the STAT. The warnings except TW are disabled when $LEDTWTH + LEDTWHYS > 1022$. All warnings except TW are disabled by default because they have 1023 in their threshold registers. All the warnings are explained below.

TW: Thermal Warning

The TW bit in the STAT is set if the junction temperature of the NCL31000 goes above TW_H. This warning is active by default and cannot be de-activated. This threshold is not programmable.

LEDTW: LED Thermal Warning

This warning will occur if the voltage on TLED pin is above LEDTWTH + LEDTWHYS. Typically, an NTC is mounted on the LED load and connected to TLED and GND. This warning is not active by default and the threshold and hysteresis are programmable.

LEDTSD: LED Thermal Shutdown

This warning will occur if the voltage on TLED pin is above LEDTSD + LEDTSDHYS. Typically, an NTC is mounted on the LED load and connected to TLED and GND. This warning is not active by default and the threshold and hysteresis are programmable.

LEDOV: LED Overvoltage

This warning will typically occur if the LED string is an open circuit. The LEDOV bit in the STAT is set if the VLED pin voltage goes above LEDOVTH + LEDOVHYS. The threshold and hysteresis are programmable.

LEDUV: LED Undervoltage

This warning will typically occur if the LED string is a short circuit. The LEDUV bit is set in the STAT. This warning is not active by default and the threshold and hysteresis are programmable.

VDD1OC and VDD2OC: VDD1x Overcurrent

A warning is given if the average current is above VDD1xOCTH + VDD1xOCHYS. Note that the DC-DC's also have a current limiting hick-up mode built-in. This warning is not active by default and the threshold and hysteresis are programmable.

Errors

There are severe error conditions that require NCL31000 to disable the block that triggered the error immediately before any damage can occur. These are LEDNOK, LEDOC and VDD2NOK. These errors are reflected in the STAT2 and STATP2/STATN2 registers. The STAT signals behavior is the same for errors and warnings. Note that typically STATN has no use for errors because the fault is gone when the micro-controller reads the registers.

In case of a desaturation fault during the switching of the transistors in the LED driver a LEDNOK error is triggered and NCL31000 will disable the LED driver block. NCL31000 will remain disabled until the LEDEN bit is reset by the user. Similarly if a desaturation fault occurs in the DC-DC2 block a VDD2NOK error is triggered and the DC-DC2 block is disabled. A LEDOC error is triggered if the LED driver sense resistor voltage crosses the OCP_TH threshold indicating a LED overcurrent. The LED block is disabled and resumes after a reset of the LEDEN bit. See figures 15 and 16 for clarification.

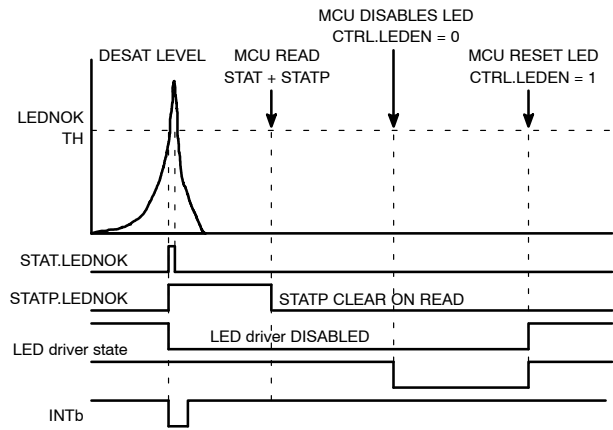

Figure 15. LEDNOK [INTCFG=1 INTP=1 INTN=X]

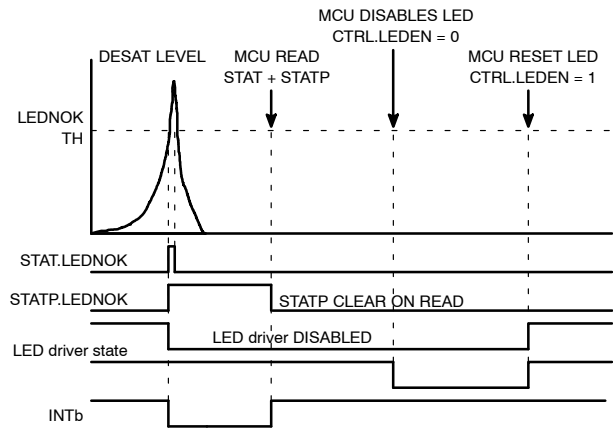

Figure 16. LEDNOK [INTCFG=0 INTP=1 INTN=X]

An error indicates that there is a hardware issue. Further explanation for each of the errors is given below.

TSD: Thermal Shutdown

When the junction temperature of the NCL31000 reaches TSD_H, the NCL31000 will shut down all functions and go into reset state. The device will remain in reset until the junction temperature drops below TSD_L.

VDD2NOK: Desaturation Error Switching Transistors

NCL31000 will shut-down DC-DC2 if this error occurs. DC-DC2 can be restarted if VDD2EN bit in CTRL is reset.

LEDNOK: Desaturation Error Switching Transistors

NCL31000 will shut-down LED block if this error occurs. The LED block can be restarted if LEDEN bit in CTRL is reset.

LEDOC: LED Overcurrent

This error can occur if the LED load wires are not well connected to the driver board and contact-bounce occurs. A sudden failure of the sense resistor can also trigger this error. NCL31000 will shut-down the LED block if this error occurs and set the LEDOC bit in the STATP.

Interrupts

The NCL31000 has a flexible interrupt mechanism that obviates the need for frequent polling. With an appropriate configuration of the two interrupt mask registers (INTP and INTN), most applications will not require polling at all, while providing for coherent status awareness in the host microcontroller. When an interrupt is triggered, INTb is pulled low. INTb is an open-drain pin to ensure multiple I²C bus participants can share the same interrupt line. A pull-up resistor must be provided externally. The NCL31000 provides an open-drain, active-low interrupt pin that activates, i.e. pulled low, when any *interrupt condition* is satisfied. An interrupt condition is satisfied if any of the bits in the STATP or STATN register is active and if the corresponding bit in the INTP and INTN are unmasked (= set).

If CTRL.INTCFG is zero (default) level interrupt is used and INTb goes low as long as the interrupt condition is satisfied. If CTRL.INTCFG is set, INTb is configured for pulsed interrupt and INTb will go low for about 10us every time the interrupt condition is satisfied.

Spread Spectrum

The purpose of spread spectrum is to continuously change the clock frequency used by the switching convertors in a periodic pattern to reduce the detected energy levels at a given frequency. It will improve the results of conducted EMI tests, not for radiated EMI. The spread spectrum block modulates the main 8 MHz clock according to a number of discrete steps in a triangular pattern as shown in figure 17. The spread clock signal is used by digital, LED driver and DC-DC convertors. The spread spectrum is disabled by default and can be enabled with the JIT_EN bit in the LEDFC register. The amount of spreading can be configured with the FDEV register. The deviation (%) is the amplitude variation towards the main clock. When the main clock is divided the same amount of spread (%) is still present on the divided clock. Table 18 relates the value for FDEV register to the amount of spreading. The default spreading when spread spectrum is enabled is 3%.

Table 18. FREQUENCY DEVIATION

FDEV [2:0]	Δ (%)
0	3
1	5
2	6
3	8
4	10
5	11
6	12.5
7	14

The FMOD register value affects the modulation period (T_{mod}) of the triangular signal. The default value for fmod is 400 Hz. The value in the FMOD register relates to fmod according to table 19.

Table 19. MODULATION FREQUENCY

FMOD [1:0]	fmod (1/T _{mod})
0	200 Hz
1	400 Hz
2	800 Hz
3	1600 Hz

The spread spectrum is illustrated with figure 17.

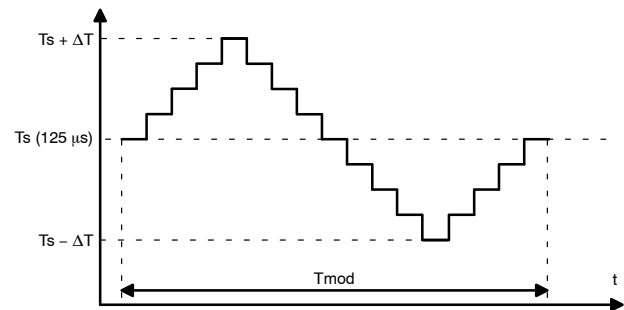

Figure 17. Spread Spectrum

Both fmod and fdev affect the modulation index of the frequency modulated clock signal.

$$MI = \frac{fdev}{fmod} \tag{eq. 29}$$

More suppression is achieved when the modulation index is higher. This is true if the RBW of the spectrum analyzer would be infinitely small, instead the RBW is 9 kHz for conducted emission measurements (150 kHz to 30 MHz) and 120 kHz for radiated emission measurements (30 MHz to 1 GHz). When the RBW is 9 kHz the spectrum analyzer will show better suppression if fmod has the maximum value.

Address Selection (NCL3100xl)

The NCL31000 comes in two variants. One with SPI interface and one with I²C interface. This is defined by OTP (One-time programmable memory) in the chip. In case the device is configured as I²C slave the ADDR1 and ADDR2 pins define the I²C slave bus address. The device can have 6 possible I²C slave addresses to differentiate devices on the same I²C-bus. The mapping between the logic level on these pins and the I²C slave address is given in table 20.

Table 20. SLAVE ADDRESS

ADDR1_CSB	ADDR2_MISO	Slave Address
GND	GND	0x50 (1010000)
VDD1	VDD1	0x52 (1010010)
FLOAT	GND	0x54 (1010100)
GND	VDD1	0x56 (1010110)
VDD1	GND	0x58 (1011000)
FLOAT	VDD1	0x5A (1011010)

I²C Interface (NCL3100xI)

The I²C interface can be used to interface with the NCL31000I in order to read or write its registers. The NCL3100I operates as an I²C slave device. The SDA and SCL lines comply with the I²C electrical specification and should be terminated with external pull-up resistors. The device supports the maximum bus speed of 400 kbit/s.

Figure 18 shows how an I²C write operation is performed. The master gives the Start condition followed by the 7-bit slave address and the read-write bit. The slave acknowledges the address. The master then places the register address on the bus. This is again acknowledged by the slave. Finally the data byte is placed on the bus by the master. The slave must acknowledge this. The master can write more than one byte in one transaction if he wishes. Writing to the registers in this case is contiguous. As more data bytes follow, the register address is auto-incremented.

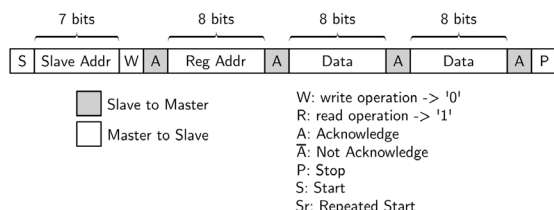

Figure 18. I²C Write Operation (2 bytes)

Figure shows how to perform an I²C read operation. The first part of a read operation is the same as for a write operation. The master provides the slave address, write bit, and register address were to read from. It then provides a repeated start condition which behaves the same as a start condition. It provides the slave address again, but this time it uses it makes the read-write bit zero to indicate a read operation. The slave acknowledges and places the requested data byte on the bus. If the master responds with a NACK (not acknowledge) and a STOP condition the message transaction is terminated. If instead the master uses an ACK it indicates to the slave that it wants to read more bytes. The slave will auto-increment the register address to read from and put the bytes on the bus as shown in Figure 20.

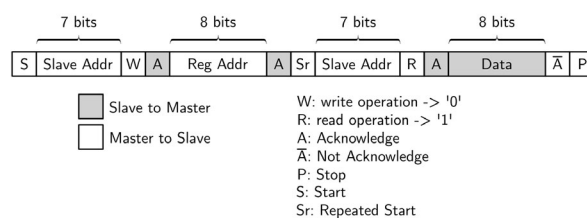

Figure 19. I²C Read Operation (1 byte)

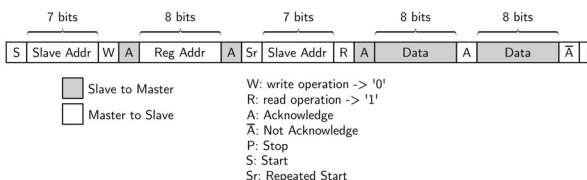

Figure 20. I²C Read Operation (2 bytes or More)

SPI Interface (NCL3100xS)

The serial peripheral interface (SPI) allows an external microcontroller (Master) to communicate with NCL31000S. The device acts always as a Slave and can't initiate any transmission. The operation of the device is configured and controlled by means of registers which are observable for read and/or write from the Master.

During a SPI transfer, data is simultaneously transmitted (shifted out serially) and received (shifted in serially). A serial clock line (SCL/CLK) synchronizes shifting and sampling of the information on the two serial data lines, MOSI (SDA_MOSI pin) and MISO (ADDR2_MISO pin). The MISO signal is the output from the slave and MOSI is the master output.

NCL31000S is configured for SPI MODE 2. This means that the signal on the MOSI/MISO data lines is sampled on the negative clock edge and that the CLK signal is high when idle. Note that the NCL31000S expects the first data signal to be present and stable on the first negative clock edge.

Figure 21 shows how to perform a SPI write operation. The master pulls the chip select signal low and a little later the master provides a minimum sequence of 16 clock cycles. During the first eight clock cycles, the master provides the register address [A6:A0] and the read-write bit on the MOSI line. If the read-write bit is high, a read operation is selected. During the following eight clock cycles, the slave clocks in the data byte [D7:D0]. If the master provides a multiple of eight clock cycles, more bytes can be written contiguously. The register counter is automatically incremented.

Figure 22 demonstrates a SPI read operation. The same principle applies as with a write operation only now the slave puts the contents of the addressed register on the MISO line during the last eight clock cycles. If the master provides a multiple of eight clock cycles more registers can be read contiguously.

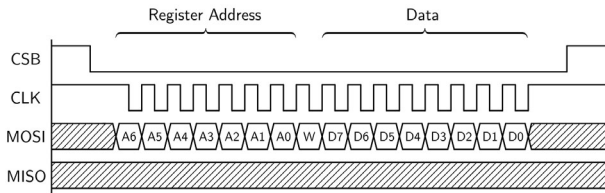

Figure 21. SPI Write Operation (1 byte)

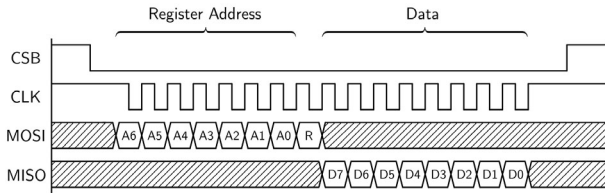

Figure 22. SPI Read Operation (1 byte)

Multiple SPI slaves can be used with one SPI master as shown in figure 23. A separate CSB signal is required for each slave. Daisy chaining is not supported.

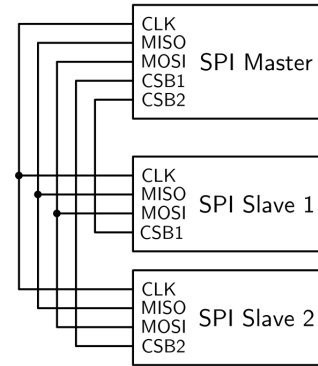

Figure 23. SPI Multi Slave

NCL31000, NCL31001

REGISTER MAP

Table 21. REGISTER MAP

Addr	Name	Reset	Bits	MSB							LSB
00 _H	RID1	00 _H	7:0	MANUF_H							
01 _H	RID2	75 _H	7:0	MANUF_L				PART_H			
02 _H	RID3	8C _H	7:0	PART_L					REV		
03 _H	Rsv.	00 _H	7:0	Rsv.							
04 _H	CTRL	00 _H	7:0	INTCFG	Rsv.				DIAG_EN	LED_EN	VDD2_EN
05 _H	STAT1	00 _H	7:0	Rsv.	TW	LEDTSD	LEDTW	LEDOV	LEDUV	VDD2OC	VDD11OC
06 _H	STAT2	00 _H	7:0	Rsv.					LEDOC	LEDNOK	VDD2NOK
07 _H	STATP1	00 _H	7:0	Rsv.	TW	LEDTSD	LEDTW	LEDOV	LEDUV	VDD2OC	VDD11OC
08 _H	STATP2	00 _H	7:0	Rsv.					LEDOC	LEDNOK	VDD2NOK
09 _H	STATN1	00 _H	7:0	Rsv.	TW	LEDTSD	LEDTW	LEDOV	LEDUV	VDD2OC	VDD11OC
0A _H	STATN2	00 _H	7:0	Rsv.					LEDOC	LEDNOK	VDD2NOK
0B _H	INTP1	00 _H	7:0	Rsv.	TW	LEDTSD	LEDTW	LEDOV	LEDUV	VDD2OC	VDD11OC
0C _H	INTP2	00 _H	7:0	Rsv.					LEDOC	LEDNOK	VDD2NOK
0D _H	INTN1	00 _H	7:0	Rsv.	TW	LEDTSD	LEDTW	LEDOV	LEDUV	VDD2OC	VDD11OC
0E _H	INTN2	00 _H	7:0	Rsv.					LEDOC	LEDNOK	VDD2NOK
10 _H	VBB	0000 _H	15:8	ADCv							
			7:0	ADCv	Rsv.						
12 _H	IBB	0000 _H	15:8	ADCv							
			7:0	ADCv	Rsv.						
14 _H	VDD11	0000 _H	15:8	ADCv							
			7:0	ADCv	Rsv.						
16 _H	IDD1	0000 _H	15:8	ADCv							
			7:0	ADCv	Rsv.						
18 _H	VDD2	0000 _H	15:8	ADCv							
			7:0	ADCv	Rsv.						
1A _H	IDD2	0000 _H	15:8	ADCv							
			7:0	ADCv	Rsv.						
1C _H	VLED	0000 _H	15:8	ADCv							
			7:0	ADCv	Rsv.						
1E _H	ILED	0000 _H	15:8	ADCv							
			7:0	ADCv	Rsv.						
20 _H	TLED	0000 _H	15:8	ADCv							
			7:0	ADCv	Rsv.						
22 _H	VDD11OCTH	FFFF _H	15:8	val							
			7:0	val	Rsv.						
24 _H	VDD2OCTH	FFFF _H	15:8	val							
			7:0	val	Rsv.						
26 _H	TLEDTWTH	FFFF _H	15:8	val							
			7:0	val	Rsv.						

NCL31000, NCL31001

Table 21. REGISTER MAP (continued)

Addr	Name	Reset	Bits	MSB	LSB			
28 _H	TLEDTSDTH	FFFF _H	15:8	val				
			7:0	val	Rsv.			
2A _H	VLEDOVTH	FFFF _H	15:8	val				
			7:0	val	Rsv.			
2C _H	VLEDUVTH	FFFF _H	15:8	val				
			7:0	val	Rsv.			
30 _H	VDD11OCTH_HYS	0A _H	7:0	Rsv.	val			
31 _H	VDD2OCTH_HYS	0A _H	7:0	Rsv.	val			
32 _H	TLEDTWTH_HYS	0A _H	7:0	Rsv.	val			
33 _H	TLEDTSDTH_HYS	0A _H	7:0	Rsv.	val			
34 _H	VLEDOVTH_HYS	0A _H	7:0	Rsv.	val			
35 _H	VLEDUVTH_HYS	0A _H	7:0	Rsv.	val			
40 _H	INTDIM	00 _H	7:0	EN	DACv			
41 _H	LEDFC	04 _H	7:0	JIT_EN	FREQ			
42 _H	SLCMP	0A _H	7:0	Rsv.		SLP2	SLP1	
50 _H	MPS	84 _H	7:0	EN	DELTA			
51 _H	FDEV	06 _H	7:0	Rsv.	SSLUT_DIS	Rsv.	FDEV	
52 _H	FMOD	01 _H	7:0	Rsv.				val

REGISTER RID1

Manufacturer, part and revision identification.

	7	6	5	4	3	2	1	0
	MANUF_H							
	r							
	0							

Bits 0–7, MANUF_H: Manufacturer ID.

REGISTER RID2

Manufacturer, part and revision identification.

	7	6	5	4	3	2	1	0
	MANUF_L				PART_H			
	r				r			
	7				5			

Bits 4–7, MANUF_L: Manufacturer ID

Bits 0–3, PART_H: Part ID

NCL31000, NCL31001

REGISTER RID3

Manufacturer, part and revision identification.

	7	6	5	4	3	2	1	0
	PART_L					REV		
	r					r		
	11 _H					4		

Bits 3–7, PART_L: Part ID.

Bits 0–2, REV: Revision ID.

1: N1A

2: O1A

3: P1A

4: Q1A

REGISTER CTRL

Control register for the major blocks in the system.

	7	6	5	4	3	2	1	0
	INTCFG	Rsv.				DIAG_EN	LED_EN	VDD2_EN
	r/w	r				r/w	r/w	r/w
	0	0				0	0	0

Bit 7, INTCFG: Define how the interrupt on the INTB line behaves.

0: The INTB pin is pulled low when an interrupt occurs. It stays low until the STATPx registers are read and provided the alert condition is gone (STATx register bits are cleared).

1: A pulse is given on each interrupt by the INTB pin.

Bits 3–6: Reserved, do not use.

Bit 2, DIAG_EN: The diagnostics function measures voltages, currents and temperatures in the system using the internal ADC.

0: Diagnostics block is disabled.

1: Diagnostics block is enabled.

Bit 1, LED_EN: Enable bit for the LED driver.

0: LED driver is disabled.

1: LED driver is enabled.

Bit 0, VDD2_EN: Enable bit for DC/DC2 converter.

0: DC/DC2 is disabled.

1: DC/DC2 is enabled.

NCL31000, NCL31001

REGISTER STAT1

A signal/alert is currently active.

	7	6	5	4	3	2	1	0
	Rsv.	TW	LEDTSD	LEDTW	LEDOV	LEDUV	VDD2OC	VDD11OC
	r	r	r	r	r	r	r	r
	0	0	0	0	0	0	0	0

- Bit 7: Reserved, do not use.
- Bit 6, TW: Thermal warning of the chip.
0: Alert is not active.
1: Alert is active.
- Bit 5, LEDTSD: LED Thermal shutdown. Is active if the voltage on the TLED pin is above TLEDTSDTH + TLED_TSDTH_HYST threshold. Becomes false if the TLED voltage drops below TLEDTSDTH - TLED_TSDTH_HYST.
0: Alert is not active.
1: Alert is active.
- Bit 4, LEDTW: LED Thermal warning. Is active if the voltage on the TLED pin is above TLEDTWTH + TLED_TWTH_HYST threshold. Becomes false if the TLED voltage drops below TLEDTWTH - TLED_TWTH_HYST.
0: Alert is not active.
1: Alert is active.
- Bit 3, LEDOV: LED Overvoltage. Is active if the voltage on the VLED pin is above VLEDOVTH + VLED_OVTH_HYST threshold. Becomes false if the VLED voltage drops below VLEDOVTH - VLED_OVTH_HYST.
0: Alert is not active.
1: Alert is active.
- Bit 2, LEDUV: LED Undervoltage. Is active if the voltage on the VLED pin is below VLEDUVTH - VLED_UVTH_HYST threshold. Becomes false if the VLED voltage is above VLEDUVTH + VLED_UVTH_HYST.
0: Alert is not active.
1: Alert is active.
- Bit 1, VDD2OC: VDD2 Overcurrent. Is active if the IDD2 current is above VDD2OCTH + VDD2_OCTH_HYST threshold. Becomes false if the VDD2OCTH current is below VDD2_OCTH_UVTH + VDD2_OCTH_HYST.
0: Alert is not active.
1: Alert is active.
- Bit 0, VDD11OC: VDD11 Overcurrent. Is active if the IDD1 current is above a fixed limit.
0: Alert is not active.
1: Alert is active.

NCL31000, NCL31001

REGISTER STAT2

A signal/alert is currently active.

	7	6	5	4	3	2	1	0
	Rsv.					LEDOC	LEDNOK	VDD2NOK
	r					r	r	r
	0					0	0	0

Bits 3–7: Reserved, do not use.

Bit 2, LEDOC: LED Overcurrent. Is active if this condition is true: $I_{LED} \times R_{sns} \times 22.0 / 3.0 > 3$.
 In reality, when this limit is crossed, a comparator will react in a matter of nanoseconds and turn off the LED driver.
 The LED current will drop immediately and the LEDOC bit in this register will be cleared before the MCU can read it and the LEDOC bit in the STATP register will be set indicating a LED overcurrent event occurred.
 0: Alert is not active.
 1: Alert is active.

Bit 1, LEDNOK: LED desaturation error. Is active if a severe error occurred in one of the switching transistors of the LED driver.
 In reality, when this limit is crossed, a comparator will react in a matter of nanoseconds and turn off the LED driver.
 The LED current will drop immediately and the LEDNOK bit in this register will be cleared before the MCU can read it and the LEDNOK bit in the STATP register will be set indicating there is a severe issue with the transistors.
 This error indicates something is wrong with the hardware of the LED driver.
 0: Alert is not active.
 1: Alert is active.

Bit 0, VDD2NOK: VDD2 desaturation error. True if a severe error occurred in of the switching transistors of the DC/DC2 converter.
 In reality, when this limit is crossed, a comparator will react in a matter of nanoseconds and turn off the DC/DC1.
 The VDD2 current will drop immediately and the VDD2NOK bit in this register will be cleared before the MCU can read it and the VDD2NOK bit in the STATP register will be set indicating there is a severe issue with the transistors.
 This error indicates something is wrong with the hardware of the VDD2 DC/DC1.
 0: Alert is not active.
 1: Alert is active.

NCL31000, NCL31001

REGISTER STATP1

A signal has become active since the last read to this register.

	7	6	5	4	3	2	1	0
	Rsv.	TW	LEDTSD	LEDTW	LEDOV	LEDUV	VDD2OC	VDD11OC
	r	r	r	r	r	r	r	r
	0	0	0	0	0	0	0	0

- Bit 7: Reserved, do not use.
- Bit 6, TW: Thermal warning of the chip.
0: Alert is not active.
1: Alert is active.
- Bit 5, LEDTSD: LED Thermal shutdown. True as long as the voltage on the TLED pin is above TLEDTSDTH + TLED_TSDTH_HYST threshold. Becomes false if the TLED voltage drops below TLEDTSDTH - TLED_TSDTH_HYST.
0: Alert is not active.
1: Alert is active.
- Bit 4, LEDTW: LED Thermal warning. True as long as the voltage on the TLED pin is above TLEDTWTH + TLED_TWTH_HYST threshold. Becomes false if the TLED voltage drops below TLEDWTH - TLED_TWTH_HYST.
0: Alert is not active.
1: Alert is active.
- Bit 3, LEDOV: LED Overvoltage. True as long as the voltage on the VLED pin is above VLEDOVTH + VLED_OVTH_HYST threshold. Becomes false if the VLED voltage drops below VLEDOVTH - VLED_OVTH_HYST.
0: Alert is not active.
1: Alert is active.
- Bit 2, LEDUV: LED Undervoltage. True as long as the voltage on the VLED pin is below VLEDUVTH - VLED_UVTH_HYST threshold. Becomes false if the VLED voltage is above VLEDUVTH + VLED_UVTH_HYST.
0: Alert is not active.
1: Alert is active.
- Bit 1, VDD2OC: VDD2 Overcurrent. True as long as the IDD2 current is above VDD2OCTH + VDD2_OCTH_HYST threshold. Becomes false if the VDD2OCTH current is below VDD2_OCTH_UVTH + VDD2_OCTH_HYST.
0: Alert is not active.
1: Alert is active.
- Bit 0, VDD11OC: VDD11 Overcurrent. True as long as the IDD1 current is above a fixed limit of
0: Alert is not active.
1: Alert is active.

NCL31000, NCL31001

REGISTER STATP2

A signal has become active since the last read to this register.

	7	6	5	4	3	2	1	0
	Rsv.					LEDOC	LEDNOK	VDD2NOK
	r					r	r	r
	0					0	0	0

Bits 3–7: Reserved, do not use.

Bit 2, LEDOC: LED Overcurrent. True as long as this condition is true: $I_{LED} \times R_{sns} \times 22.0 / 3.0 > 3$.
In reality, when this limit is crossed, a comparator will react in a matter of nanoseconds and turn off the LED driver.

The LED current will drop immediately and the LEDOC bit in this register will be cleared before the MCU can read it and the LEDOC bit in the STATP register will be set indicating a LED overcurrent event occurred.

0: Alert is not active.

1: Alert is active.

Bit 1, LEDNOK: LED desaturation error. True if a severe error occurred in of the switching transistors of the LED driver.
In reality, when this limit is crossed, a comparator will react in a matter of nanoseconds and turn off the LED driver.

The LED current will drop immediately and the LEDNOK bit in this register will be cleared before the MCU can read it and the LEDNOK bit in the STATP register will be set indicating there is a severe issue with the transistors.

This error indicates something is wrong with the hardware of the LED driver.

0: Alert is not active.

1: Alert is active.

Bit 0, VDD2NOK: VDD2 desaturation error. True if a severe error occurred in of the switching transistors of the DC/DC2 converter.

In reality, when this limit is crossed, a comparator will react in a matter of nanoseconds and turn off the DC/DC1.

The VDD2 current will drop immediately and the VDD2NOK bit in this register will be cleared before the MCU can read it and the VDD2NOK bit in the STATP register will be set indicating there is a severe issue with the transistors.

This error indicates something is wrong with the hardware of the VDD2 DC/DC1.

0: Alert is not active.

1: Alert is active.

REGISTER STATN1

A signal has become inactive since the last read to this register.

	7	6	5	4	3	2	1	0
	Rsv.	TW	LEDTSD	LEDTW	LEDOV	LEDUV	VDD2OC	VDD11OC
	r	r	r	r	r	r	r	r
	0	0	0	0	0	0	0	0

This register has the same structure as STATP1; refer there for more information.

REGISTER STATN2

A signal has become inactive since the last read to this register.

	7	6	5	4	3	2	1	0
	Rsv.					LEDOC	LEDNOK	VDD2NOK
	r					r	r	r
	0					0	0	0

This register has the same structure as STATP2; refer there for more information.

NCL31000, NCL31001

REGISTER INTP1

Interrupt enable register for STATP1. Defines which alert signals, if they become active, result in an interrupt condition on the INTB line.

	7	6	5	4	3	2	1	0
	Rsv.	TW	LEDTSD	LEDTW	LEDOV	LEDUV	VDD2OC	VDD11OC
	r	r/w	r/w	r/w	r/w	r/w	r/w	r/w
	0	0	0	0	0	0	0	0

- Bit 7: Reserved, do not use.
- Bit 6, TW: Thermal warning.
0: Interrupt disabled/masked.
1: Interrupt enabled.
- Bit 5, LEDTSD: LED Thermal shutdown.
0: Interrupt disabled/masked.
1: Interrupt enabled.
- Bit 4, LEDTW: LED Thermal warning.
0: Interrupt disabled/masked.
1: Interrupt enabled.
- Bit 3, LEDOV: LED Overvoltage.
0: Interrupt disabled/masked.
1: Interrupt enabled.
- Bit 2, LEDUV: LED Undervoltage.
0: Interrupt disabled/masked.
1: Interrupt enabled.
- Bit 1, VDD2OC: VDD2 Overcurrent.
0: Interrupt disabled/masked.
1: Interrupt enabled.
- Bit 0, VDD11OC: VDD11 Overcurrent.
0: Interrupt disabled/masked.
1: Interrupt enabled.

REGISTER INTP2

Interrupt mask register for STATP2. Defines which alert signals, if they become active, result in an interrupt condition on the INTB line.

	7	6	5	4	3	2	1	0
	Rsv.					LEDOC	LEDNOK	VDD2NOK
	r					r/w	r/w	r/w
	0					0	0	0

- Bits 3–7: Reserved, do not use.
- Bit 2, LEDOC: LED Overcurrent.
0: Interrupt disabled/masked.
1: Interrupt enabled.
- Bit 1, LEDNOK: LED desaturation error.
0: Interrupt disabled/masked.
1: Interrupt enabled.
- Bit 0, VDD2NOK: VDD2 desaturation error.
0: Interrupt disabled/masked.
1: Interrupt enabled.

NCL31000, NCL31001

REGISTER INTN1

Interrupt enable register for STATN1. Defines which alert signals, if they become active, result in an interrupt condition on the INTB line.

	7	6	5	4	3	2	1	0
	Rsv.	TW	LEDTSD	LEDTW	LEDOV	LEDUV	VDD2OC	VDD11OC
	r	r/w	r/w	r/w	r/w	r/w	r/w	r/w
	0	0	0	0	0	0	0	0

This register has the same structure as INTP1; refer there for more information.

REGISTER INITN2

Interrupt mask register for STATN2. Defines which alert signals, if they become active, result in an interrupt condition on the INTB line.

	7	6	5	4	3	2	1	0
	Rsv.					LEDOC	LEDNOK	VDD2NOK
	r					r/w	r/w	r/w
	0					0	0	0

This register has the same structure as INTP2; refer there for more information.

REGISTER VBB

VBB–GND voltage measurement.

15	14	13	12	11	10	9	8	7	6	5	4	3	2	1	0
ADCv										Rsv.					
r										r					
0										0					

Bits 6–15, ADCv: ADC value.

Bits 0–5: Reserved, do not use.

REGISTER IBB

IBB current measurement.

15	14	13	12	11	10	9	8	7	6	5	4	3	2	1	0
ADCv										Rsv.					
r										r					
0										0					

Bits 6–15, ADCv: ADC value.

Bits 0–5: Reserved, do not use.

REGISTER VDD11

VDD11 voltage measurement.

15	14	13	12	11	10	9	8	7	6	5	4	3	2	1	0
ADCv										Rsv.					
r										r					
0										0					

This register has the same structure as IBB; refer there for more information.

NCL31000, NCL31001

REGISTER IDD1

IDD1 current measurement.

15	14	13	12	11	10	9	8	7	6	5	4	3	2	1	0
ADCv										Rsv.					
r										r					
0										0					

This register has the same structure as IBB; refer there for more information.

REGISTER VDD2

VDD2 voltage measurement.

15	14	13	12	11	10	9	8	7	6	5	4	3	2	1	0
ADCv										Rsv.					
r										r					
0										0					

This register has the same structure as IBB; refer there for more information.

REGISTER IDD2

IDD2 current measurement.

15	14	13	12	11	10	9	8	7	6	5	4	3	2	1	0
ADCv										Rsv.					
r										r					
0										0					

This register has the same structure as IBB; refer there for more information.

REGISTER VLED

VLED current measurement.

15	14	13	12	11	10	9	8	7	6	5	4	3	2	1	0
ADCv										Rsv.					
r										r					
0										0					

This register has the same structure as IBB; refer there for more information.

REGISTER ILED

ILED current measurement.

15	14	13	12	11	10	9	8	7	6	5	4	3	2	1	0
ADCv										Rsv.					
r										r					
0										0					

This register has the same structure as IBB; refer there for more information.

NCL31000, NCL31001

REGISTER TLED

TLED voltage measurement.

15	14	13	12	11	10	9	8	7	6	5	4	3	2	1	0
ADCv										Rsv.					
r										r					
0										0					

This register has the same structure as IBB; refer there for more information.

REGISTER VDD11OCTH

VDD11 overcurrent threshold register.

15	14	13	12	11	10	9	8	7	6	5	4	3	2	1	0
val										Rsv.					
r/w										r					
3FF _H										3F _H					

Bits 6–15, val: value.
1023: The detection is disabled.

Bits 0–5: Reserved, do not use.

REGISTER VDD2OCTH

VDD2 overcurrent threshold register.

15	14	13	12	11	10	9	8	7	6	5	4	3	2	1	0
val										Rsv.					
r/w										r					
3FF _H										3F _H					

This register has the same structure as VDD11OCTH; refer there for more information.

REGISTER TLEDTWTH

TLED thermal warning threshold register.

15	14	13	12	11	10	9	8	7	6	5	4	3	2	1	0
val										Rsv.					
r/w										r					
3FF _H										3F _H					

This register has the same structure as VDD11OCTH; refer there for more information.

REGISTER TLEDTSDTH

TLED thermal shutdown threshold register.

15	14	13	12	11	10	9	8	7	6	5	4	3	2	1	0
val										Rsv.					
r/w										r					
3FF _H										3F _H					

This register has the same structure as VDD11OCTH; refer there for more information.

NCL31000, NCL31001

REGISTER VLEDOVTH

VLED overvoltage threshold register.

15	14	13	12	11	10	9	8	7	6	5	4	3	2	1	0
val										Rsv.					
r/w										r					
3FF _H										3F _H					

This register has the same structure as VDD11OCTH; refer there for more information.

REGISTER VLEDUVTH

VLED undervoltage threshold register.

15	14	13	12	11	10	9	8	7	6	5	4	3	2	1	0
val										Rsv.					
r/w										r					
3FF _H										3F _H					

This register has the same structure as VDD11OCTH; refer there for more information.

REGISTER VDD11OCTH_HYS

Overcurrent threshold hysteresis register.

							7	6	5	4	3	2	1	0	
							Rsv.	val							
							r	r/w							
							0	0A _H							

Bit 7: Reserved, do not use.

Bits 0–6, val: value.

REGISTER VDD2OCTH_HYS

Overcurrent threshold hysteresis register.

							7	6	5	4	3	2	1	0	
							Rsv.	val							
							r	r/w							
							0	0A _H							

Bit 7: Reserved, do not use.

Bits 0–6, val: value.

REGISTER TLEDTWTH_HYS

LED thermal warning threshold hysteresis register.

							7	6	5	4	3	2	1	0	
							Rsv.	val							
							r	r/w							
							0	0A _H							

This register has the same structure as VDD2OCTH_HYS; refer there for more information.

NCL31000, NCL31001

REGISTER TLEDTSDTH_HYS

TLED thermal shutdown threshold hysteresis register.

	7	6	5	4	3	2	1	0	
	Rsv.	val							
	r	r/w							
	0	0A _H							

This register has the same structure as VDD2OCTH_HYS; refer there for more information.

REGISTER VLEDOVTH_HYS

VLED overvoltage threshold hysteresis register.

	7	6	5	4	3	2	1	0	
	Rsv.	val							
	r	r/w							
	0	0A _H							

This register has the same structure as VDD2OCTH_HYS; refer there for more information.

REGISTER VLEDUVTH_HYS

VLED undervoltage threshold hysteresis register.

	7	6	5	4	3	2	1	0	
	Rsv.	val							
	r	r/w							
	0	0A _H							

This register has the same structure as VDD2OCTH_HYS; refer there for more information.

REGISTER INTDIM

Internal DIM register.

	7	6	5	4	3	2	1	0	
	EN	DACv							
	r/w	r/w							
	0	0							

Bit 7, EN: Internal DIM enable.
0: The internal DIM is disabled.
1: The internal DIM is enabled.

Bits 0–6, DACv: Internal DAC value.

NCL31000, NCL31001

REGISTER LEDFC

LED driver switching frequency register.

	7	6	5	4	3	2	1	0
	JIT_EN	FREQ						
	r/w	r/w						
	0	4						

- Bit 7, JIT_EN: Spread spectrum enable.
 0: Spread spectrum disabled.
 1: Spread spectrum enabled.
- Bits 0–6, FREQ: Switching frequency value.
 0: 1 MHz switching frequency.
 1: 800 kHz switching frequency.
 2: 666 kHz switching frequency.
 3: 571 kHz switching frequency.
 4: 500 kHz switching frequency.
 5: 444 kHz switching frequency.
 6: 400 kHz switching frequency.
 7: 363 kHz switching frequency.
 8: 333 kHz switching frequency.
 9: 307 kHz switching frequency.
 10: 285 kHz switching frequency.
 11: 250 kHz switching frequency.
 12: 235 kHz switching frequency.
 13: 210 kHz switching frequency.
 14: 190 kHz switching frequency.
 15: 173 kHz switching frequency.

REGISTER SLCMP

LED driver slope compensation register.

	7	6	5	4	3	2	1	0
	Rsv.				SLP2		SLP1	
	r				r/w		r/w	
	0				2		2	

- Bits 4–7: Reserved, do not use.
- Bits 2–3, SLP2: Slope compensation applicable when LED driver is operating in 50% to 100% duty-cycle range.
 0: 0.3 V/μs
 1: 0.4 V/μs
 2: 0.6 V/μs
 3: 0.9 V/μs
- Bits 0–1, SLP1: Slope compensation applicable when LED driver is operating in 0 to 50% duty-cycle range.
 0: 0.1 V/μs
 1: 0.2 V/μs
 2: 0.3 V/μs
 3: 0.4 V/μs

NCL31000, NCL31001

REGISTER MPS

Maintain Power Signature register.

	7	6	5	4	3	2	1	0
	EN	DELTA						
	r/w	r/w						
	1	4						

Bit 7, EN: MPS enable.

- 0: MPS disabled.
- 1: MPS enabled.

Bits 0–6, DELTA: Define how long the MPS pulse lasts. The minimum MPS pulse is about 7 ms if LCF bit is active and 75 ms if the LCF bit is disabled.

The DELTA value defines how many ms are added to the minimum MPS time.

- 0: Add 0 ms to the minimum MPS pulse.
- 63: Add 63 ms to the minimum MPS pulse.
- 127: Add 127 ms to the minimum MPS pulse.

REGISTER FDEV

Frequency Deviation register.

	7	6	5	4	3	2	1	0
	Rsv.	SSLUT_DIS		Rsv.		FDEV		
	r	r/w		r		r/w		
	0	0		0		6		

Bit 7: Reserved, do not use.

Bits 5–6, SSLUT_DIS: Spread Spectrum Look-up Table Disable.

0: The FDEV and FMOD field values are directly used for the spread spectrum block (expert mode). The user is responsible for calculating the amount of spread.

1: The spread spectrum block calculates the needed deviation and modulation values to achieve a certain amount of spread (%) based on the FDEV and FMOD field values. The relation between FMOD/FDEV and the amount of spread (%) is given in a lookup table.

Bits 3–4: Reserved, do not use.

Bits 0–2, FDEV: Frequency Deviation value.

- 0: 1.8 MHz deviation.
- 1: 914 kHz deviation.
- 2: 479 kHz deviation.
- 3: 322 kHz deviation.
- 4: 246 kHz deviation.
- 5: 165 kHz deviation.
- 6: 100 kHz deviation.
- 7: 56 kHz deviation.

NCL31000, NCL31001

REGISTER FMOD

Frequency Modulation register.

	7	6	5	4	3	2	1	0
	Rsv.						val	
	r						r/w	
	0						1	

Bits 2–7: Reserved, do not use.
Bits 0–1, val: Frequency Modulation value.
0: 200 Hz modulation.
1: 400 Hz modulation.
2: 800 Hz modulation.
3: 1600 Hz modulation.

NCL31000, NCL31001

PACKAGE DIMENSIONS

QFN48 7x7, 0.5P
CASE 485EP
ISSUE O

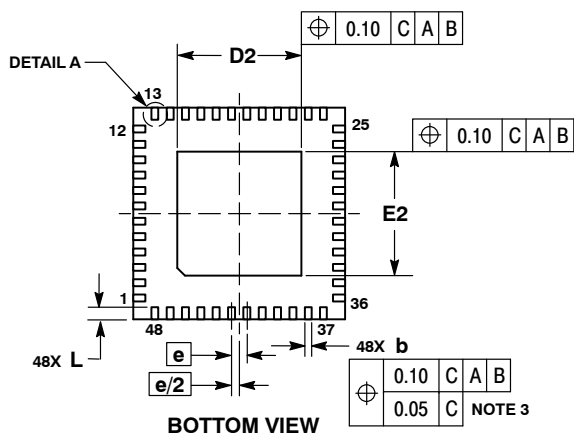
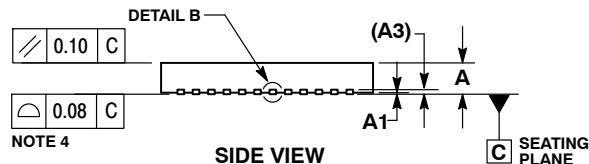
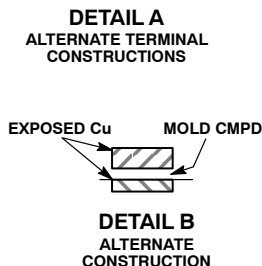
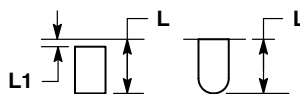
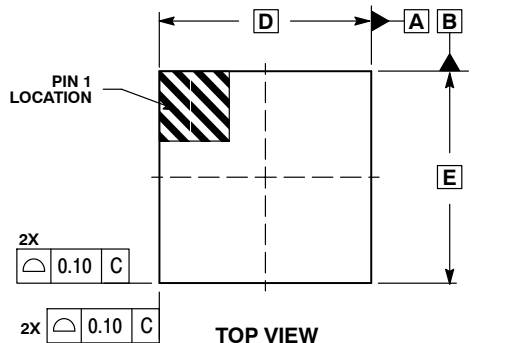

RECOMMENDED SOLDERING FOOTPRINT*

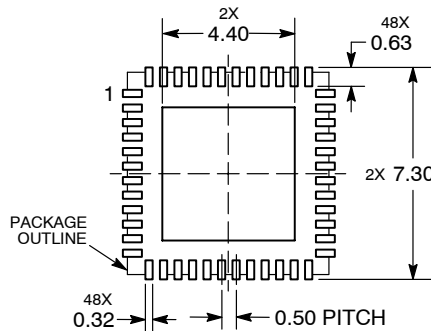

DIMENSIONS: MILLIMETERS

*For additional information on our Pb-Free strategy and soldering details, please download the ON Semiconductor Soldering and Mounting Techniques Reference Manual, SOLDERRM/D.

NOTES:

1. DIMENSIONS AND TOLERANCING PER ASME Y14.5M, 1994.
2. CONTROLLING DIMENSION: MILLIMETERS.
3. DIMENSION b APPLIES TO THE PLATED TERMINAL AND IS MEASURED BETWEEN 0.15 AND 0.25 MM FROM THE TERMINAL TIP.
4. COPLANARITY APPLIES TO THE EXPOSED PAD AS WELL AS THE TERMINALS.

MILLIMETERS		
DIM	MIN	MAX
A	0.80	1.00
A1	0.00	0.05
A3	0.20 REF	
b	0.20	0.30
D	7.00 BSC	
D2	4.00	4.20
E	7.00 BSC	
E2	4.00	4.20
e	0.50 BSC	
L	0.30	0.50
L1	0.00	0.15

All brand names and product names appearing in this document are registered trademarks or trademarks of their respective holders. ON Semiconductor is licensed by the Philips Corporation to carry the I²C bus protocol.

ON Semiconductor and are trademarks of Semiconductor Components Industries, LLC dba ON Semiconductor or its subsidiaries in the United States and/or other countries. ON Semiconductor owns the rights to a number of patents, trademarks, copyrights, trade secrets, and other intellectual property. A listing of ON Semiconductor's product/patent coverage may be accessed at www.onsemi.com/site/pdf/Patent-Marking.pdf. ON Semiconductor reserves the right to make changes without further notice to any products herein. ON Semiconductor makes no warranty, representation or guarantee regarding the suitability of its products for any particular purpose, nor does ON Semiconductor assume any liability arising out of the application or use of any product or circuit, and specifically disclaims any and all liability, including without limitation special, consequential or incidental damages. Buyer is responsible for its products and applications using ON Semiconductor products, including compliance with all laws, regulations and safety requirements or standards, regardless of any support or applications information provided by ON Semiconductor. "Typical" parameters which may be provided in ON Semiconductor data sheets and/or specifications can and do vary in different applications and actual performance may vary over time. All operating parameters, including "Typicals" must be validated for each customer application by customer's technical experts. ON Semiconductor does not convey any license under its patent rights nor the rights of others. ON Semiconductor products are not designed, intended, or authorized for use as a critical component in life support systems or any FDA Class 3 medical devices or medical devices with a same or similar classification in a foreign jurisdiction or any devices intended for implantation in the human body. Should Buyer purchase or use ON Semiconductor products for any such unintended or unauthorized application, Buyer shall indemnify and hold ON Semiconductor and its officers, employees, subsidiaries, affiliates, and distributors harmless against all claims, costs, damages, and expenses, and reasonable attorney fees arising out of, directly or indirectly, any claim of personal injury or death associated with such unintended or unauthorized use, even if such claim alleges that ON Semiconductor was negligent regarding the design or manufacture of the part. ON Semiconductor is an Equal Opportunity/Affirmative Action Employer. This literature is subject to all applicable copyright laws and is not for resale in any manner.

PUBLICATION ORDERING INFORMATION

LITERATURE FULFILLMENT:
Email Requests to: orderlit@onsemi.com

TECHNICAL SUPPORT
North American Technical Support:
Voice Mail: 1 800-282-9855 Toll Free USA/Canada
Phone: 011 421 33 790 2910

Europe, Middle East and Africa Technical Support:
Phone: 00421 33 790 2910
For additional information, please contact your local Sales Representative

Looking for pricing, stock, or lifecycle information?

Click below to explore more details on WIN SOURCE:

- ⊖ [View NCL31001MNITWG on WIN SOURCE](#)
- ⊖ [ON Semiconductor Information](#)

Optimize Your Supply Chain with WIN SOURCE Solutions

- ✓ Global Sourcing Solution
- ✓ Obsolete Management
- ✓ Cost Control Management
- ✓ Shortage Management
- ✓ Alternative Solution
- ✓ Excess Inventory Management