



**THE DATASHEET OF  
DS2118MB**



### FEATURES

- Fully Compliant with SCSI SPI-2, SPI-3, SPI-4, Ultra160, and Ultra320
- Provides Multimode Low-Voltage Differential/Single-Ended (LVD/SE) Termination for Nine Signal Line Pairs
- Autoselection of LVD or SE Termination
- 5% Tolerance on SE and LVD Termination Resistance
- Low Power-Down Capacitance of 3pF
- On-Board Thermal Shutdown Circuitry
- SCSI Bus Hot-Plug Compatible
- Fully Supports Actively Negated SE SCSI Signals

### PIN CONFIGURATION

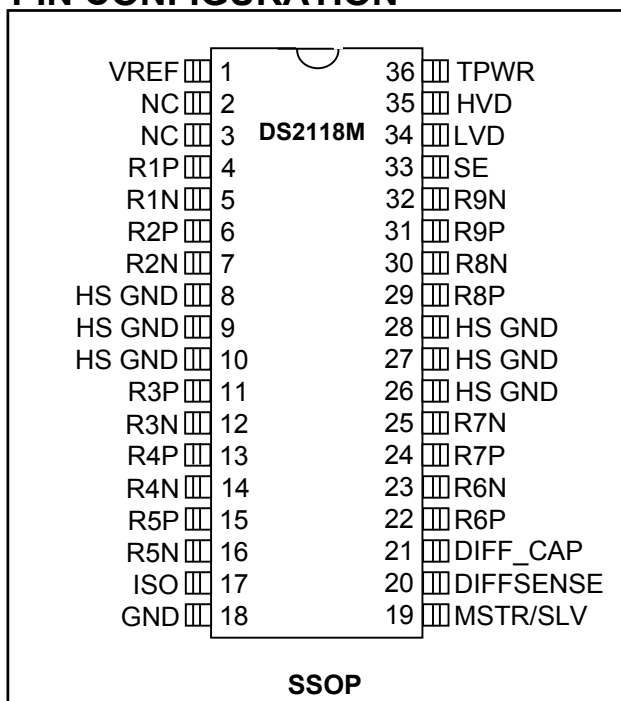

### ORDERING INFORMATION

PART	VOLTAGE (V)	TEMP RANGE	PIN-PACKAGE	TOP MARK*
DS2118MB	5	0°C to +70°C	36 SSOP (0.300")	DS2118MB
DS2118MB+	5	0°C to +70°C	36 SSOP (0.300")	DS2118MB
DS2118MB/T&R	5	0°C to +70°C	36 SSOP (0.300")/Tape and Reel	DS2118MB
DS2118MB+T&R	5	0°C to +70°C	36 SSOP (0.300")/Tape and Reel	DS2118MB

+ Denotes a lead-free/RoHS-compliant package.

\* The top mark includes a "+" on lead-free packages.

## DETAILED DESCRIPTION

The DS2118M Ultra3 LVD/SE SCSI terminator is both a low-voltage differential (LVD) and single-ended (SE) terminator. The multimode operation enables the designer to implement LVD in current products while allowing the end-user SE-backward compatibility with legacy devices. If the device is connected in an LVD-only bus, the DS2118M will use LVD termination. If any SE devices are connected to the bus, the DS2118M will use SE termination. This is accomplished automatically inside the part by sensing the voltage on the SCSI bus DIFFSENS line.

For the LVD termination, the DS2118M integrates two current sources with nine precision resistor strings. For the SE termination, one regulator and nine precision 110 $\Omega$  resistors are used. Three DS2118M terminators are needed for a wide SCSI bus.

## REFERENCE DOCUMENTS

Small Computer Systems Interface (SCSI-3)	SCSI Parallel Interface (SPI)	Project: 0855-M, 1995
Small Computer Systems Interface (SCSI-3)	SCSI Parallel Interface 2 (SPI-2)	Project: 1142-M, 1998
Small Computer Systems Interface (SCSI-3)	SCSI Parallel Interface 3 (SPI-3)	Project: 1302-D, 1999
Small Computer Systems Interface (SCSI-3)	SCSI Parallel Interface 4 (SPI-4)	Project: 1365-D, 200x

### Available From:

American National Standards Institute (ANSI) Phone: (212) 642-4900

Global Engineering Documents 15 Inverness Way East; Englewood, CO 80112 Phone: (800) 854-7179

## FUNCTIONAL DESCRIPTION

The DS2118 combines LVD and SE termination with DIFFSENSE sourcing and detection.

A bandgap reference is fed into two amplifiers, which creates a 1.25V reference voltage and a 2.85V reference voltage. The control logic determines which of these references will be applied to the termination resistors. If the SCSI bus is in LVD mode, then the 1.25V reference will be used. If the SCSI bus is in SE mode, then the 2.85V reference will be used. That same control logic will switch in/out parallel resistors to change the total termination resistance accordingly. Finally, in SE mode the Rp pins will be switched to ground.

The DIFFSENSE circuitry decodes trinary logic. There will be one of three voltages on the SCSI control line called DIFFSENS. Two comparators and a NAND gate determine if the voltage is below 0.6V, above 2.15V, or in between. That indicates the mode of the bus to be HVD, SE, or LVD, respectively.

The DS2118M's DIFF\_CAP pin monitors the DIFFSENS line to determine the proper operating mode of the device; this mode is indicated by the SE/LVD/HVD outputs. The DIFFSENSE pin can also drive the SCSI DIFFSENS line (when MSTR/SLV = 1) to determine the SCSI bus operating mode. The DS2118M switches to the termination mode that is appropriate for the bus based on the value of the DIFFSENS voltage. These modes are:

- **LVD Mode:** LVD termination is provided by a precision laser-trimmed resistor string with two amplifiers. This configuration yields a 105Ω differential and 150Ω common-mode impedance. A fail-safe bias of 112mV is maintained when no drivers are connected to the SCSI bus.
- **SE Mode:** When the external driver for a given signal line turns off, the active terminator will pull that signal line to 2.85V (quiescent state). When used with an active negation driver, the power amp can sink 22mA per line while keeping the voltage reference in regulation. The terminating resistors maintain their 110Ω value.
- **HVD Isolation Mode:** The DS2118M identifies that there is an HVD (high-voltage differential) device on the SCSI bus and isolates the termination pins from the bus.

When ISO is pulled high, the termination pins are isolated from the SCSI bus,  $V_{REF}$  remains active, and the bus mode indicators (SE/LVD/HVD) remain active. During thermal shutdown, the termination pins are isolated from the SCSI bus,  $V_{REF}$  becomes high impedance, and the bus mode indicators (SE/LVD/HVD) remain active. The DIFFSENSE driver is shut down during either of these two events. An internal pulldown resistor assures that the DS2118M will be terminating the bus if the ISO pin is left floating.

To ensure proper operation, the TPWR pin should be connected to the SCSI bus TERMPWR line. As with all analog circuitry, the TERMPWR and  $V_{DD}$  lines should be bypassed locally. A 2.2μF capacitor and a 0.01μF high-frequency capacitor is recommended between TPWR and ground and placed as close as possible to the DS2118M. The DS2118M should be placed as close as possible to the SCSI connector to minimize signal and power-trace length, thereby resulting in less input capacitance and reflections, which can degrade the bus signals.

To maintain the specified regulation, a 4.7μF capacitor is required between the  $V_{REF}$  pin (VREF) and ground of each DS2118M. A high frequency cap (0.1μF ceramic recommended) can also be placed on the

---

$V_{REF}$  pin in applications that use fast rise/fall time drivers. A typical SCSI bus configuration is shown in Figure 2.

**NOTES:**

- 1) DIFFSENS. Refers to the SCSI bus signal.
- 2) DIFFSENSE. Refers to the DS2118M pin name and internal circuitry capable of driving the DIFFSENS line.
- 3) DIFF\_CAP. Refers to the DS2118M pin name and internal circuitry relating to monitoring the DIFFSENS line.

Figure 1. DS2118M Block Diagram

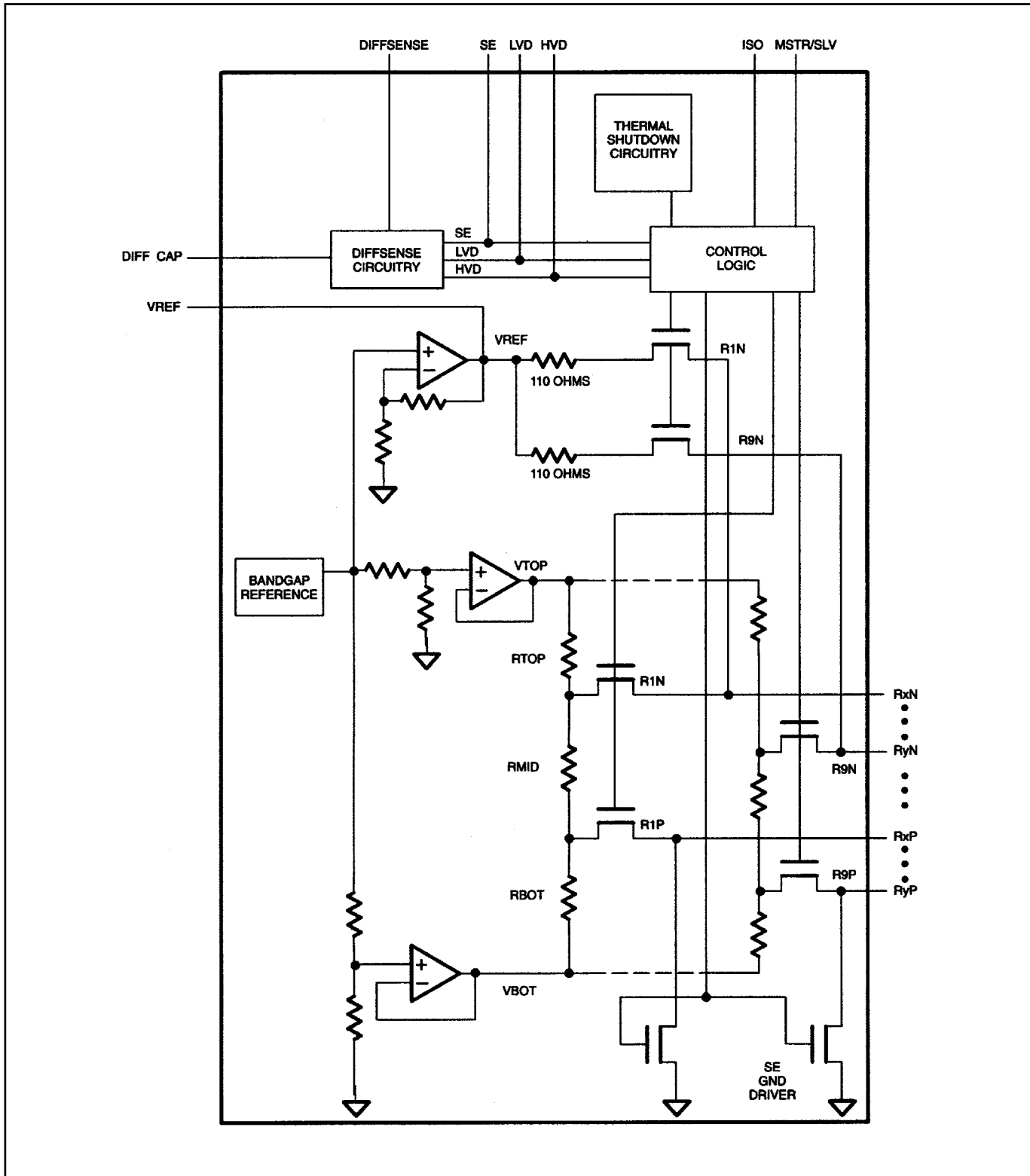
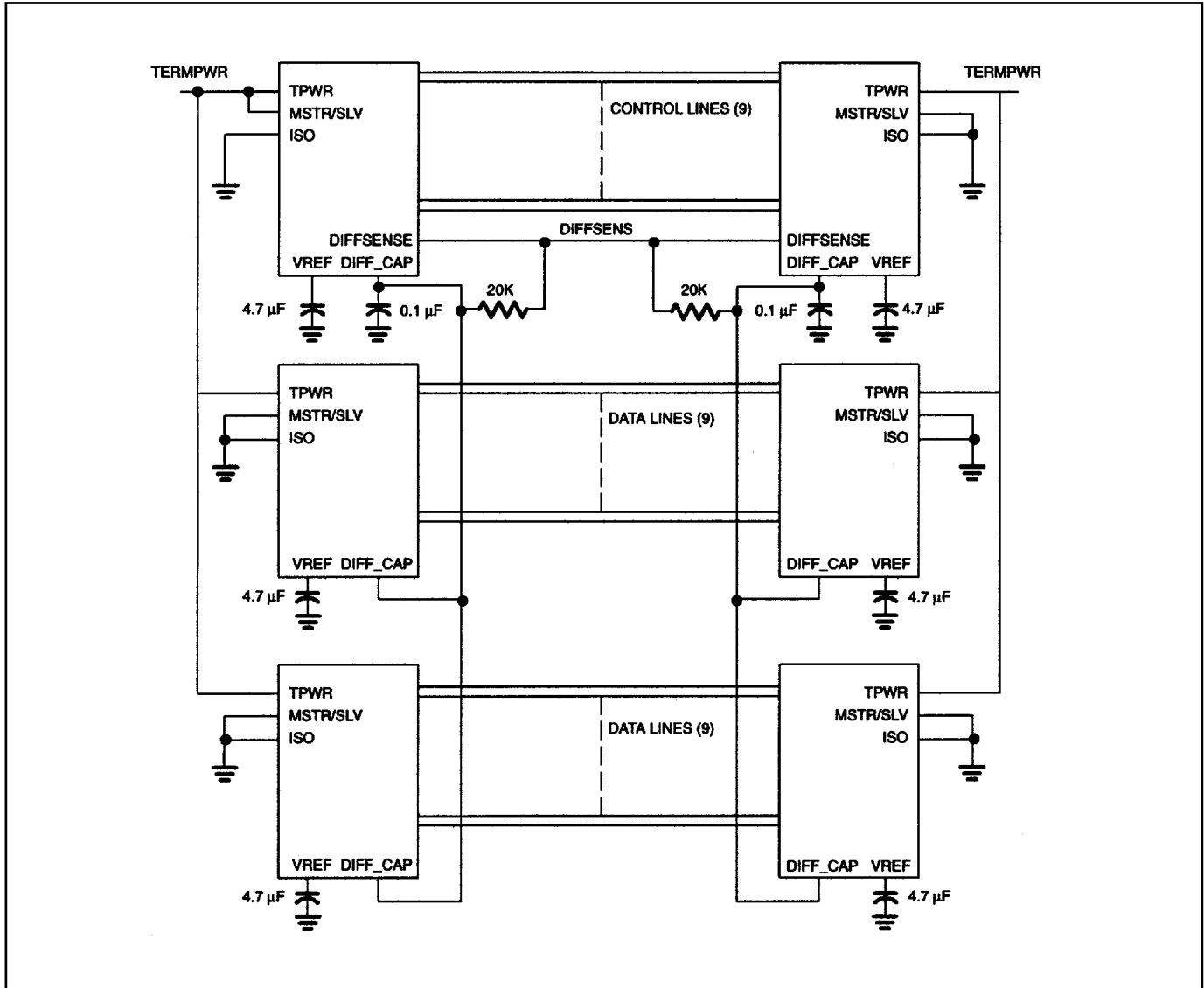

Figure 2. SCSI Bus Configuration



**PIN DESCRIPTION**

PIN	NAME	FUNCTION
1	VREF	<b>Reference Voltage.</b> 2.85V reference in SE mode and 1.25V reference in LVD mode; must be decoupled with a 4.7 $\mu$ F cap.
2, 3	NC	<b>No Connection.</b> Do not connect these pins.
4–7, 11–16, 22–25, 29–32	RxP, RxN	<b>Signal Termination.</b> Connect to SCSI bus signal lines.
8, 10, 26, 9, 28, 27	HS GND	<b>Heat Sink Ground.</b> Internally connected to the mounting pad. Should be grounded.
17	ISO	<b>Isolation.</b> When pulled high, the DS2118M isolates its bus pins (RxP, FxP) from the SCSI bus.
18	GND	<b>Ground.</b> Signal ground; 0V.
19	MSTR/SLV	<b>Master/Slave.</b> Mode-select for the noncontrolling terminator. When pulled high (MSTR), the DIFFSENSE driver is enabled.
20	DIFFSENSE	<b>DIFFSENSE.</b> Output to drive the SCSI bus DIFFSENS line.
21	DIFF_CAP	<b>DIFFSENSE Capacitor.</b> Connect 0.1 $\mu$ F capacitor for DIFFSENSE filter. Input to detect the type of device (differential or single-ended) on the SCSI bus.
33	SE	<b>Single-Ended.</b> SE output of DIFFSENSE receiver; indicates SE bus operation.
34	LVD	<b>Low-Voltage Differential.</b> LVD output of DIFFSENSE receiver; indicates LVD bus operation.
35	HVD	<b>High-Voltage Differential.</b> HVD output of DIFFSENSE receiver; indicates HVD bus operation or thermal shutdown.
36	TPWR	<b>Termination Power.</b> Connect to the SCSI TERMPWR line and decouple with 2.2 $\mu$ F capacitor.

**RECOMMENDED OPERATING CONDITIONS**

PARAMETER		SYMBOL	MIN	TYP	MAX	UNITS	NOTES
Termpower Voltage	SE Mode	$V_{TPWR(SE)}$	4.0		5.5	V	
	LVD Mode	$V_{TPWR(LVD)}$	2.7		5.5	V	
Logic 0		$V_{IL}$	-0.3		+0.8	V	
Logic 1		$V_{IH}$	2.0		$V_{TPWR} + 0.3$	V	
Operating Temperature		$V_{AMB}$	0		70	$^{\circ}$ C	

**SINGLE-ENDED CHARACTERISTICS**

PARAMETER	SYMBOL	MIN	TYP	MAX	UNITS	NOTES
SE Termination Resistance	$R_{SE}$	104.5	110	115.5	$\Omega$	1
SE Voltage Reference	$V_{REF}$	2.7		3.0	V	
SE Output Current	$I_{OSE}$			25.4	mA	2
Output Capacitance	$C_{OUT}$			3	pF	3

**LOW-VOLTAGE DIFFERENTIAL CHARACTERISTICS**

PARAMETER	SYMBOL	MIN	TYP	MAX	UNITS	NOTES
Differential Mode Termination Resistance	$R_{DM}$	100		110	$\Omega$	
Common Mode Termination Resistance	$R_{CM}$	110		190	$\Omega$	
Differential Mode Bias	$V_{DM}$	100		125	mV	4
Common Mode Bias	$V_{CM}$	1.125		1.375	V	

**DC CHARACTERISTICS**

PARAMETER	SYMBOL	MIN	TYP	MAX	UNITS	NOTES
Termpower Current	$I_{TPMR}$		12		mA	4
Input Leakage High	$I_{IH}$	-1.0			$\mu$ A	
Input Leakage Low	$I_{IL}$			1.0	$\mu$ A	
Output Current High	$I_{OH}$	-1.0			mA	5, 7
Output Current Low	$I_{OL}$	4.0			mA	6, 7
DIFFSENS SE Operating Range	$V_{SEOR}$	-0.3		0.5	V	
DIFFSENS LVD Operating Range	$V_{LVDOR}$	0.7		1.9	V	
DIFFSENS HVD Operating Range	$V_{HVDOR}$	2.4		$V_{TPWR} + 0.3$	V	
DIFFSENSE Driver Output Voltage	$V_{DSO}$	1.2		1.4	V	8, 9
DIFFSENSE Driver Source Current	$I_{DSH}$	5		15	mA	8, 10, 12
DIFFSENSE Driver Sink Current	$I_{DSL}$	20		200	$\mu$ A	8, 11
Thermal Shutdown			150		$^{\circ}$ C	3

**REGULATOR CHARACTERISTICS**

PARAMETER	SYMBOL	MIN	TYP	MAX	UNITS	NOTES
Line Regulation	$LI_{REG}$		1.0	2.5	%	
Load Regulation	$LO_{REG}$		1.3	3.5	%	
Current Limit	$I_{LIM}$		550		mA	
Sink Current	$I_{SINK}$	200			mA	

**NOTES:**

- 1)  $V_{LINE} = 0V$  to  $3V$ .
- 2)  $V_{LINE} = 0.2V$ .
- 3) Guaranteed by design.
- 4) All lines open.
- 5)  $V_{OUT} = 2.4V$ .
- 6)  $V_{OUT} = 0.4V$ .
- 7) SE/LVD/HVD pins only.
- 8) MSTR/SLV = 1.
- 9)  $I_{DS} = 0mA$  to  $5mA$ .
- 10)  $V_{DSO} = 0V$ .
- 11)  $V_{DSO} = 2.75V$ .
- 12) TPWR =  $5.5V$ .

## PACKAGE INFORMATION

(The package drawing(s) in this data sheet may not reflect the most current specifications. For the latest package outline information, go to [www.maxim-ic.com/DallasPackInfo](http://www.maxim-ic.com/DallasPackInfo).)

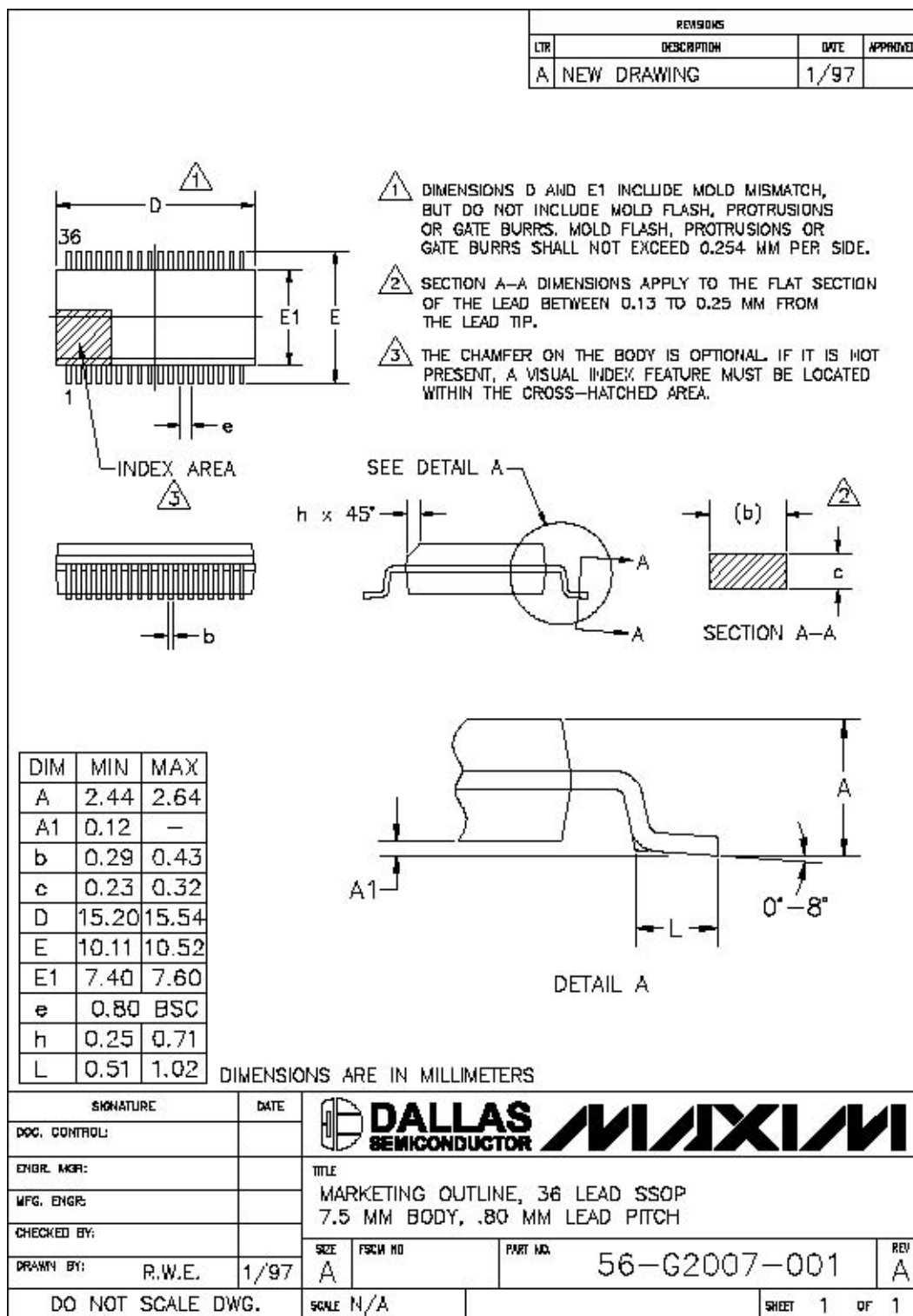

10 of 10

Maxim/Dallas Semiconductor cannot assume responsibility for use of any circuitry other than circuitry entirely embodied in a Maxim/Dallas Semiconductor product. No circuit patent licenses are implied. Maxim/Dallas Semiconductor reserves the right to change the circuitry and specifications without notice at any time.

**Maxim Integrated Products, 120 San Gabriel Drive, Sunnyvale, CA 94086 408-737-7600**

© 2006 Maxim Integrated Products • Printed USA

## Looking for pricing, stock, or lifecycle information?

Click below to explore more details on WIN SOURCE:

 [View DS2118MB](#) on WIN SOURCE

 [Maxim Integrated](#) Information

## Optimize Your Supply Chain with WIN SOURCE Solutions

-  Global Sourcing Solution
-  Obsolete Management
-  Cost Control Management
-  Shortage Management
-  Alternative Solution
-  Excess Inventory Management