



**DALLAS**  
SEMICONDUCTOR

**DS2114**  
SCSI Terminator

## FEATURES

- Fully compliant with SCSI, SCSI-2 and SCSI-3 standards
- Provides active termination for nine signal lines
- Laser-trimmed 110 ohms termination resistors have 2% tolerance
- Low dropout voltage regulator
- Fully supports actively negated SCSI signals
- Onboard thermal shutdown circuitry
- Narrow 16-pin plastic SOIC (DS2114Z)

## PIN ASSIGNMENT

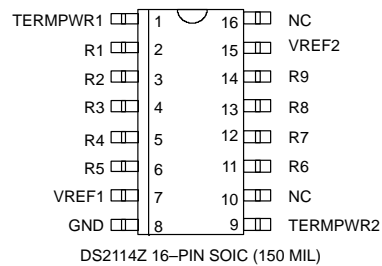

## DESCRIPTION

The SCSI-2 and SCSI-3 standards recommend the use of active terminations at both ends of every cable segment in a SCSI system with single-ended drivers and receivers. The DS2114 SCSI Terminator, which is fully compliant with these standards, enables the designer to gain the benefits of active termination: greater immunity to voltage drops on the TERMPWR (Termination PoWeR) line, enhanced high-level noise im-

munity, intrinsic TERMPWR decoupling, and very low quiescent current consumption. The DS2114 integrates a regulator and nine precise 110 ohms termination resistors into a monolithic IC. The DS2114 is intended for cable end terminator assemblies and devices where the terminators do not need to be isolated from the SCSI bus.

**FUNCTIONAL DESCRIPTION**

The DS2114 consists of a bandgap reference, buffer amplifier, and nine termination resistors (Figure 1). The bandgap reference circuit produces a precise 2.55 volts level which is fed to a buffer amplifier. The buffer produces a 2.85 volts level and is capable of sourcing at least 24 mA into each of the termination resistors when the signal line is low (active). When the driver for a given signal line turns off, the terminator will pull the signal line to 2.85 volts (quiescent state). To handle actively negated SCSI signals, the buffer can sink at least 200 mA and  $V_{ref}$  will move less than 60 mV. When all lines settle in the quiescent state, the regulator will consume about 2.5 mA.

To ensure proper operation, both the TERMPWR1 and TERMPWR2 pins must be connected to the SCSI bus TERMPWR line and both the VREF1 and VREF2 pins must be tied together externally. Each DS2114 requires a 4.7  $\mu$ F capacitor connected between the VREF pins and ground. Figure 2 details a typical SCSI bus configuration. In an 8-bit wide SCSI bus arrangement ("A" Cable), two DS2114's would be needed at each end of the SCSI cable in order to terminate the 18 active signal lines. In a 16-bit wide SCSI bus arrangement ("P" Cable), three DS2114's would be needed at each end of the SCSI cable in order to terminate the 27 active signal lines.

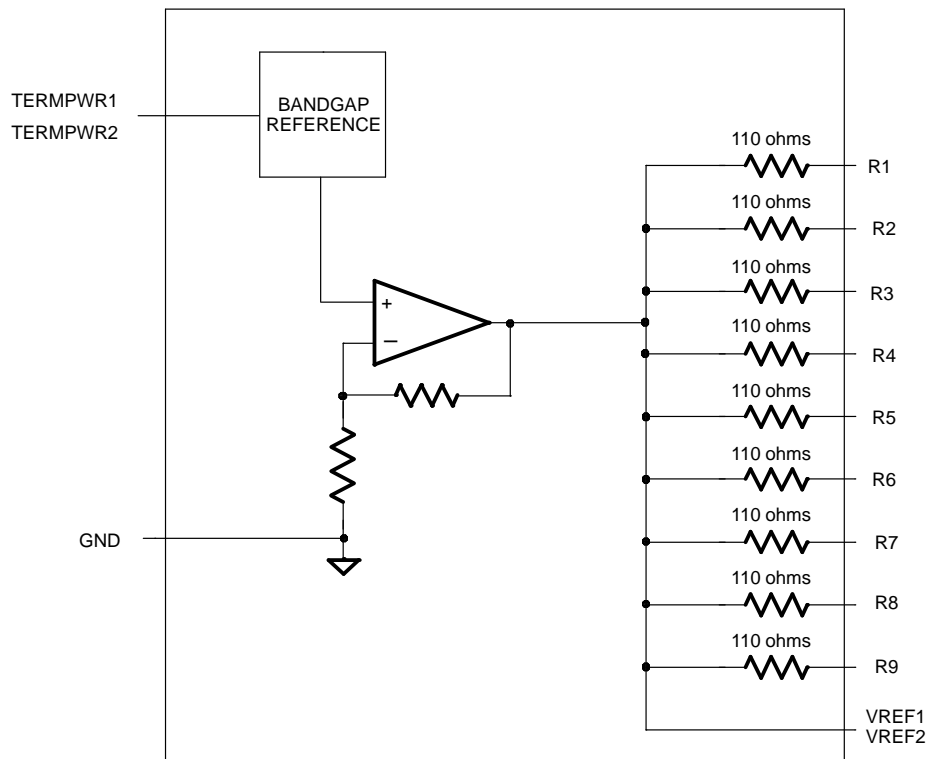
**DS2114 BLOCK DIAGRAM** Figure 1

TYPICAL SCSI BUS CONFIGURATION Figure 2

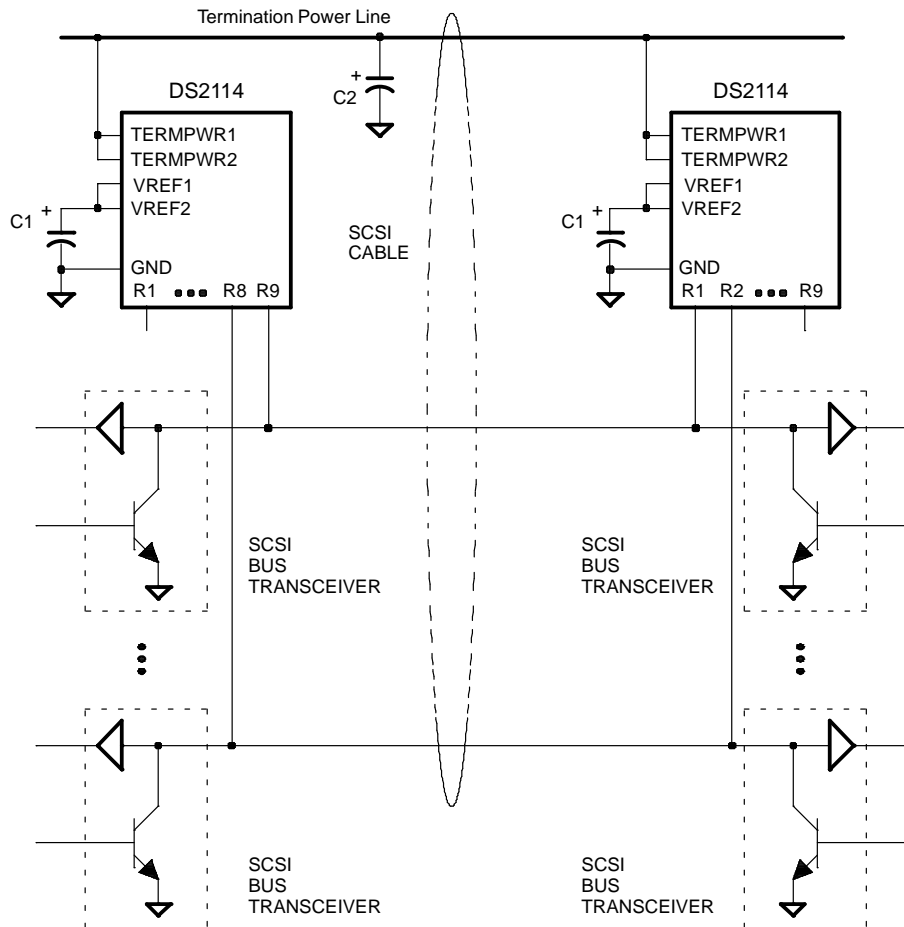
**NOTES:**

1. C1 = 4.7  $\mu$ F tantalum  
C2 = 2.2  $\mu$ F tantalum or 4.7  $\mu$ F aluminum
2. If the DS2114 is to be embedded into a peripheral that will act as a target on a SCSI bus, it is recommended that TERMPWR be derived from the SCSI cable, not generated locally. In this configuration, if a power failure occurs in the peripheral, it will not affect the bus.
3. A high frequency bypass capacitor (0.1  $\mu$ F recommended) can be added in parallel to C1 for applications using fast rise/fall time drivers.

**PIN DESCRIPTION** Table 1

DS2114Z PIN	SYMBOL	DESCRIPTION
1	TERMPWR1	<b>Termination Power 1.</b> Should be connected to the SCSI TERMPWR line. Must be decoupled with either a 2.2 $\mu$ F or 4.7 $\mu$ F. See Figure 2.
2	R1	<b>Signal Termination 1.</b> 110 ohms termination.
3	R2	<b>Signal Termination 2.</b> 110 ohms termination.
4	R3	<b>Signal Termination 3.</b> 110 ohms termination.
5	R4	<b>Signal Termination 4.</b> 110 ohms termination.
6	R5	<b>Signal Termination 5.</b> 110 ohms termination.
7	VREF1	<b>Reference Voltage 1.</b> Must be externally connected directly to the VREF2 pin. Must be decoupled with a 4.7 $\mu$ F capacitor as shown in Figure 2.
8	GND	<b>Ground.</b> Signal ground; 0.0 volts.
9	TERMPWR2	<b>Termination Power 2.</b> Should be connected to the SCSI TERMPWR line. Must be decoupled with either a 2.2 $\mu$ F or 4.7 $\mu$ F. See Figure 2.
11	R6	<b>Signal Termination 6.</b> 110 ohms termination.
12	R7	<b>Signal Termination 7.</b> 110 ohms termination.
13	R8	<b>Signal Termination 8.</b> 110 ohms termination.
14	R9	<b>Signal Termination 9.</b> 110 ohms termination.
10, 16	NC	<b>No Connect.</b> Do not connect any signal to these pins.
15	VREF2	<b>Reference Voltage 2.</b> Must be externally connected directly to the VREF1 pin. Must be decoupled with a 4.7 $\mu$ F capacitor as shown in Figure 2.

**ABSOLUTE MAXIMUM RATINGS\***

Voltage on Any Pin Relative to Ground	-1.0V to +7.0V
Operating Temperature	0°C to 70°C
Storage Temperature	-55°C to +125°C
Soldering Temperature	260°C for 10 seconds

\* This is a stress rating only and functional operation of the device at these or any other conditions above those indicated in the operation sections of this specification is not implied. Exposure to absolute maximum rating conditions for extended periods of time may affect reliability.

The Dallas Semiconductor DS2114 is built to the highest quality standards and manufactured for long term reliability. All Dallas Semiconductor devices are made using the same quality materials and manufacturing methods. However, the DS2114 is not exposed to environmental stresses, such as burn-in, that some industrial applications require. For specific reliability information on this product, please contact the factory in Dallas at (972) 371-4448.

**RECOMMENDED OPERATING CONDITIONS**

(0°C to 70°C)

PARAMETER	SYMBOL	MIN	TYP	MAX	UNITS	NOTES
TERMPWR Voltage	$V_{TP}$	4.00		5.50	V	

**DC CHARACTERISTICS**

(0°C to 70°C)

PARAMETER	SYMBOL	MIN	TYP	MAX	UNITS	NOTES
TERMPWR Current	$I_{TP}$			250	mA	1, 3
	$I_{TP}$		5	8	mA	1, 4
Termination Resistance	$R_{TERM}$	110		116	ohms	1, 2
Die Thermal Shutdown	$T_{SD}$	150			°C	1, 5
Termination Capacitance	$C_T$		5.0		pF	1, 2, 5

**REGULATOR CHARACTERISTICS**

(0°C to 70°C)

PARAMETER	SYMBOL	MIN	TYP	MAX	UNITS	NOTES
Output Voltage	$V_{REF}$	2.7	2.85	3.0	V	1, 2
Drop Out Voltage	$V_{DROP}$		0.75	1.0	V	3, 5
Line Regulation	$L_{REG}$		1.0	2.0	%	1, 4
Output Current	$I_{OUT}$			24.0	mA	6
Load Regulation	$L_{OREG}$		1.3	3.0	%	1, 3
Current Limit	$I_{LIM}$	280		500	mA	1
Sink Current	$I_{SINK}$	200			mA	1

**NOTES:**

- 4.00 volts < TERMPWR < 5.50 volts.
- 0.0 volts < signal lines < TERMPWR.
- All signal lines = 0.0 volts.
- All signal lines open.
- Guaranteed by design; not production tested.
- $V_{SIGNAL} = 0.2V$ .

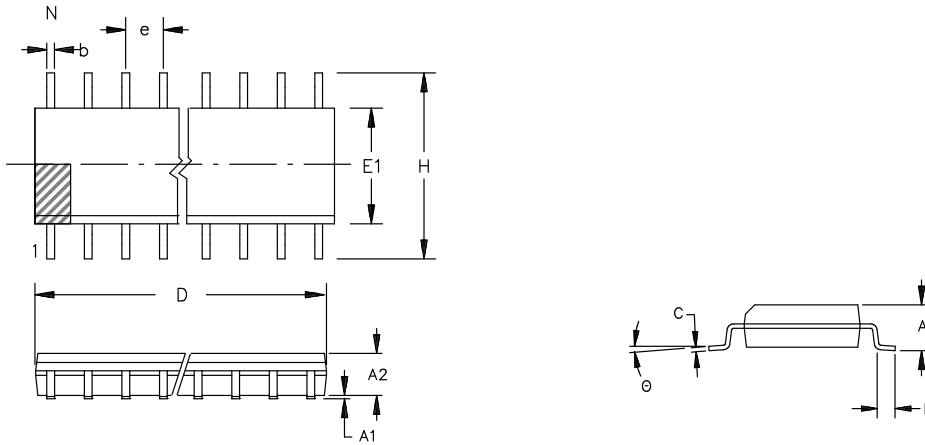

**DS2114Z SCSI TERMINATOR 16-PIN SOIC (150 MIL)**







PKG	16-PIN	
DIM	MIN	MAX
A IN. MM	0.053 1.35	0.069 1.75
A1 IN. MM	0.004 0.10	0.010 0.25
A2 IN. MM	0.048 1.24	0.062 1.57
b IN. MM	0.012 0.30	0.020 0.50
C IN MM	0.007 0.17	0.011 0.28
D IN. MM	0.386 9.80	0.393 9.98
e IN. MM	0.050 BSC 1.27 BSC	
E1 IN. MM	0.150 3.81	0.158 4.01
H IN. MM	0.230 5.84	0.244 6.20
L IN. MM	0.016 0.40	0.050 0.89
θ	0°	8°

## Looking for pricing, stock, or lifecycle information?

Click below to explore more details on WIN SOURCE:

-  [View DS2114Z on WIN SOURCE](#)
-  [Maxim Integrated](#) Information

## Optimize Your Supply Chain with WIN SOURCE Solutions

-  Global Sourcing Solution
-  Obsolete Management
-  Cost Control Management
-  Shortage Management
-  Alternative Solution
-  Excess Inventory Management