



**THE DATASHEET OF
TM21R-5C-88(50)**



Modular Jack Connectors for High Speed LAN Transmission

TM21R Series

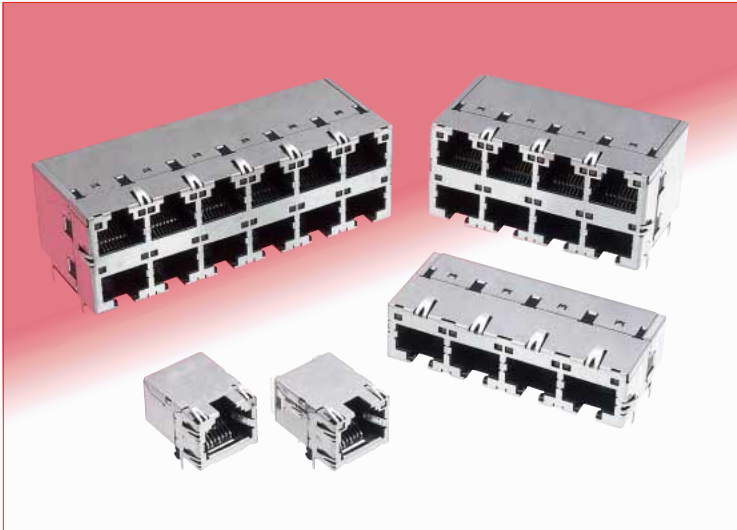

Built-in Light Indicators

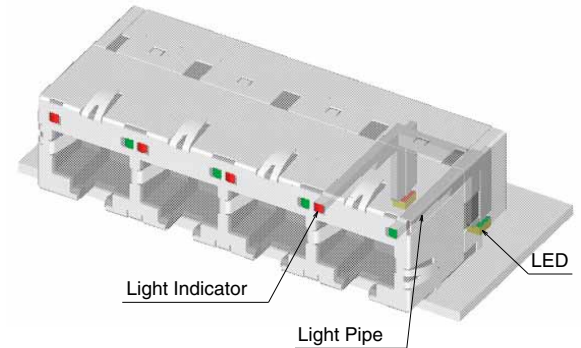

■ Features

1. Supports High Speed LAN Transmission

Complies with TIA/EIA-568-B data wiring requirements, guaranteeing Cat.5e transmission for the single port configuration and Cat.5 transmission performance for the multi-port configuration.

As such, these products fully support Gigabit Ethernet (1000BASE-T) and Fast Ethernet (100BASE-TX) high speed LAN transmission.

2. Built-in Light Indicators

There is no need to design a separate space for the light indicators as they are built-in the connector, enabling space-saving. (Fig.1)

Compared with LED type indicators, they do not emit any electrical noise. (Fig.2)

3. EMI protection

Metal shield covers the outer surfaces of the connectors assuring complete protection against electromagnetic interference.

4. FCC Standards

Meets requirements of FCC Title 47, Part 68, Subpart F.

5. THR (Through-Hole Mounting) Type

THR (Through-Hole Mounting) compatible type is available.

■ Applications

LAN Equipment, Office Equipment and Measuring Devices.

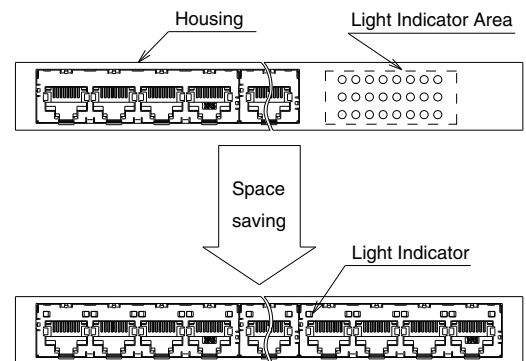

One additional TM21 multi-port jack can be mounted in the space previously occupied by LEDs.

Fig.1

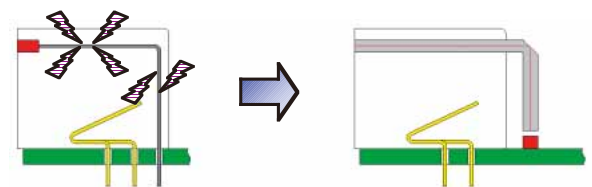

Built-in LED Type
(Easily affected by
noise.)

Built-in Light Pipe Type
(Not affected by noise.)

Fig.2

■ Product Specifications

Ratings	Rated Current 1A	Operating Temperature : -55 to +85°C (Note)
	Rated Voltage 125V AC	Storage Temperature Range : -25 to +60°C

Item	Specification	Conditions
1. Insulation Resistance	100MΩ min	100V DC
2. Withstanding Voltage (Between Adjacent Contacts)	No flashover or insulation breakdown	500V AC for 1min.
3. Withstanding Voltage (Between Contact and Shield)	No flashover or insulation breakdown	1500V AC for 1min.
4. Contact Resistance	230mΩ max.	100mA DC
5. Vibration	No electrical discontinuity of 5 μs or more Contact resistance : 250mΩ max.	Frequency : 10 to 55 Hz, single amplitude of 0.75mm, 2 hours / 3 axis
6. Shock	No electrical discontinuity of 5 μs or more Contact resistance : 250mΩ max.	Acceleration of 490 m/s ² , 11 ms duration, sine half-wave waveform, 3 cycles in each of the 3 axis
7. Mating Durability	Contact resistance : 250mΩ max.	200 cycles
8. Temperature Cycle	Contact resistance : 250mΩ max. Insulation resistance : 100MΩ min.	(Temperature : -55°C → +5°C to +35°C → +85°C → +5°C to +35°C Duration : 30 → 5 → 30 → 5 (Minutes) 5 cycles
9. Humidity	Contact resistance : 250mΩ max. Insulation resistance : 1MΩ min. (High humidity) Insulation resistance : 10MΩ min. (Dry state)	500 hours at temperature of 40°C and humidity of 90% to 95%
10. Salt Spray	Contact resistance : 250mΩ max.	Exposed to density 5% salt water for 48 hours

Note : Includes temperature rise caused by current flow.

■ Materials / Finish

Part	Material	Finish	Remarks
Insulator	Synthetic Resin	Color : Black	UL94V-0
Contact	Copper Alloy	Contact Area : Gold Plating 1.27 μ Termination Area : Gold Plating	—
Light Pipe	Polycarbonate	Color : Clear	—
Shield	Copper Alloy	Tin Plating	—

■ Product Number Structure

Refer to the chart below when determining the product specifications from the product number.
Please select from the product numbers listed in this catalog when placing orders.

● Jacks

TM21 R - 5 A - 32 32 D - LP (50)

① ② ③ ④ ⑤ ⑥ ⑦ ⑧ ⑨

① Series Name	TM21
② Connector Type	R : Jack
③ Jack Type Number	5 : Right Angle PCB Through-Hole Type
④ Jack Performance Level Code	A : Cat.5 (Single row, multi-port) B : Cat.5 (Double row, multi port) C : Supports Cat.5e (Single port)
⑤ Jack Mating Port Size	8 : 8 contacts 32 : 8 contacts /4 ports 48 : 8 contact/6 ports
⑥ Number of Contacts	8 : 8 contacts 32 : 8 contacts inserted in 4 ports=32 contacts 48 : 8 contacts inserted in 6 ports=48 contacts
⑦ Number of Rows	Blank : Single row D : Double row
⑧ Option	LP : With light pipe inserted Blank : Without light pipe DIR : THR (Through-Hole Mounting)
⑨ RoHS Compliant	(50)

■ Modular Jack Connectors Supporting Cat.5e

● Single Port With Built-in Light Pipe



Part No.	HRS No.	RoHS
TM21R-5C-88-LP(50)	222-2892-0 50	YES

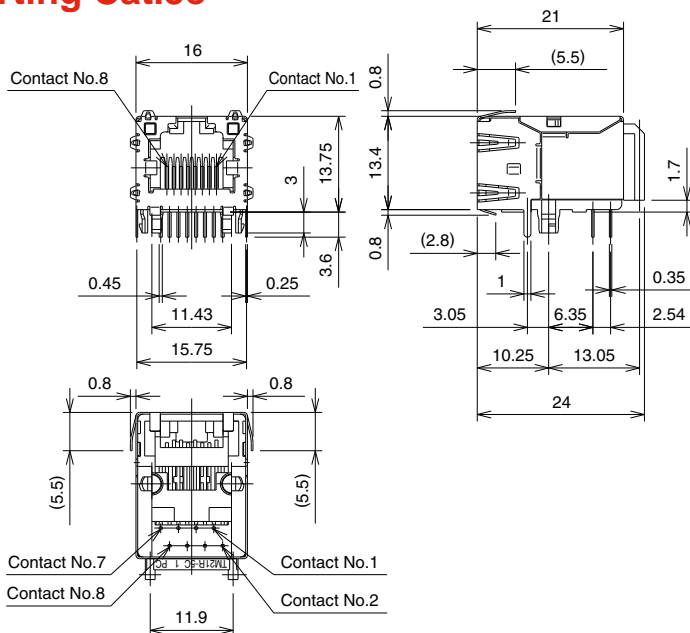

● Single Port Without Light Pipe

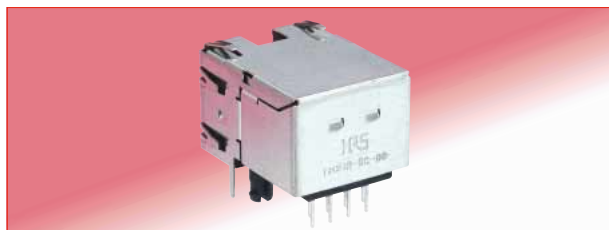

Part No.	HRS No.	RoHS
TM21R-5C-88(50)	222-2893-2 50	YES

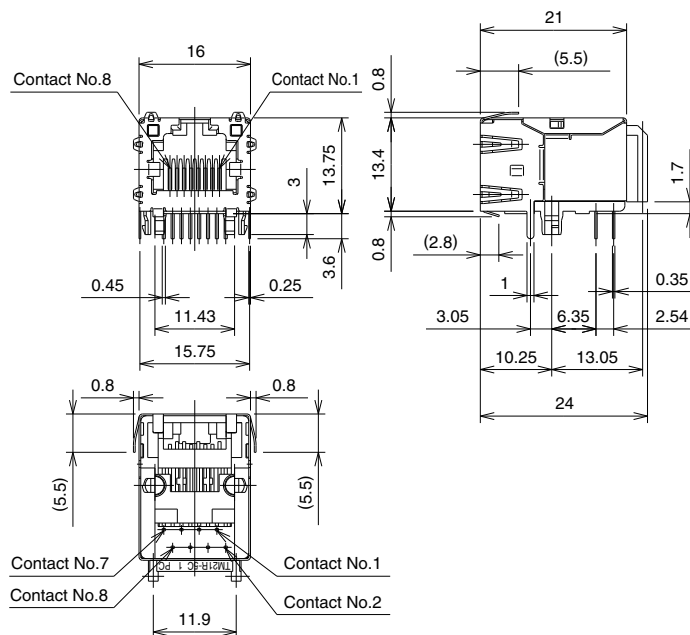

● Single Port (Through-Hole Mounting Type)

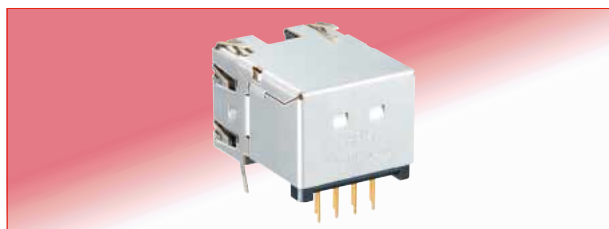

Part No.	HRS No.	RoHS
TM21R-5C-88-DIR	222-2091-0 00	YES

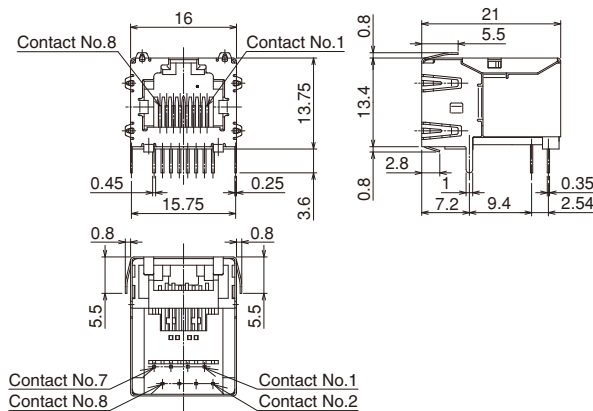

◆ Recommended PCB Mounting Patterns

● With Built-in Light Pipe

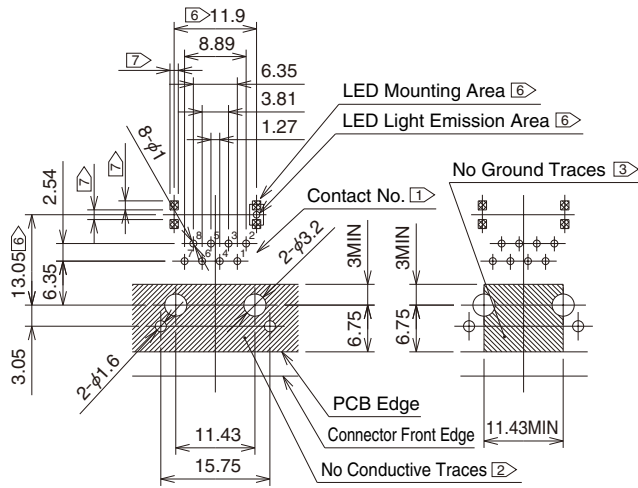

● Without Light Pipe

● Through-Hole Mounting Type

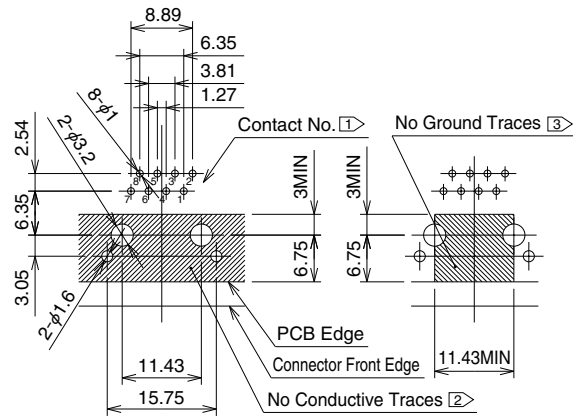

*Recommendations for PCB Design

- 1 Note that the contact arrangement for contact No.1 and No.2 and No.7 and No.8 are switched.
- 2 Areas indicated should be free of conductive traces.
- 3 Area indicated should be free of ground traces.
- 4 Recommended board thickness: 1.6mm.
- 5 The LED for the jack connector with built-in light pipe is mounted on the PCB. Please use an LED within the specified dimensions. For LED specifications, contact the LED manufacturer.
- 6 Mount so that the center of the light emitting part of the LED is at the center of the dimensions indicated in the diagram.
- 7 Please check the latest dimension of LED pad with the corresponding LED manufacturer before designing.

1 Contact Arrangement

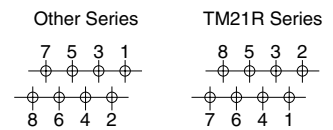

5 Applicable LEDs

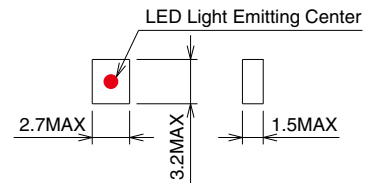

◆ Recommended Panel Cutout Diagram

● Same Recommended Cutout for Built-in Light Indicator Type, Type Without Light Indicator and Through-Hole Mounting Type

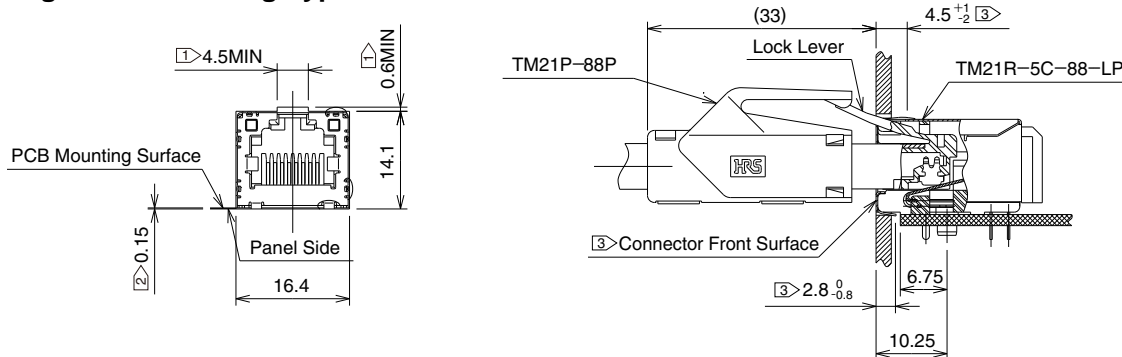

*Recommendations for Panel Design

- 1 When making the panel, make a notch according to the dimensions shown as a relief for the plug lock lever.
- 2 Set the panel mounting position so that the bottom surface of the panel is 0.15mm below the PCB mounting surface.
- 3 The contact position of the contact spring is 4.5+/-0.2 (top and sides) and 2.8-0.8 (back side) from the front surface of the connector. Please be careful when setting the panel position.

● Usage Precautions for Built-in Light Pipe Type

IPA cleaning at room temperature is recommended for cleaning. When using a liquid-based cleaning agent, the color of the light pipe (made of polycarbonate resin) may change. Please select a cleaning agent after reviewing the table of cleaning agent effects on resin issued by cleaning agent manufacturers.

■ Modular Receptacles Supporting Cat.5

● 1 Row × 4 Ports

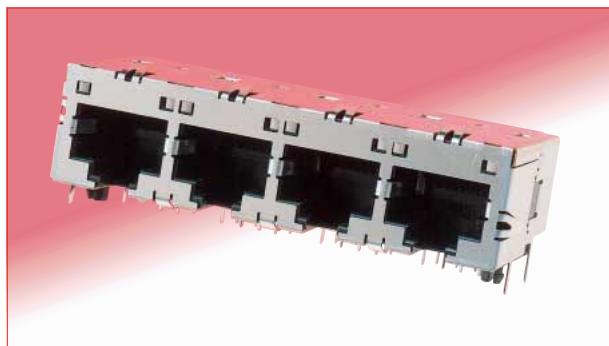

Part No.	HRS No.	RoHS
TM21R-5A-3232-LP(50)	222-2873-50	YES

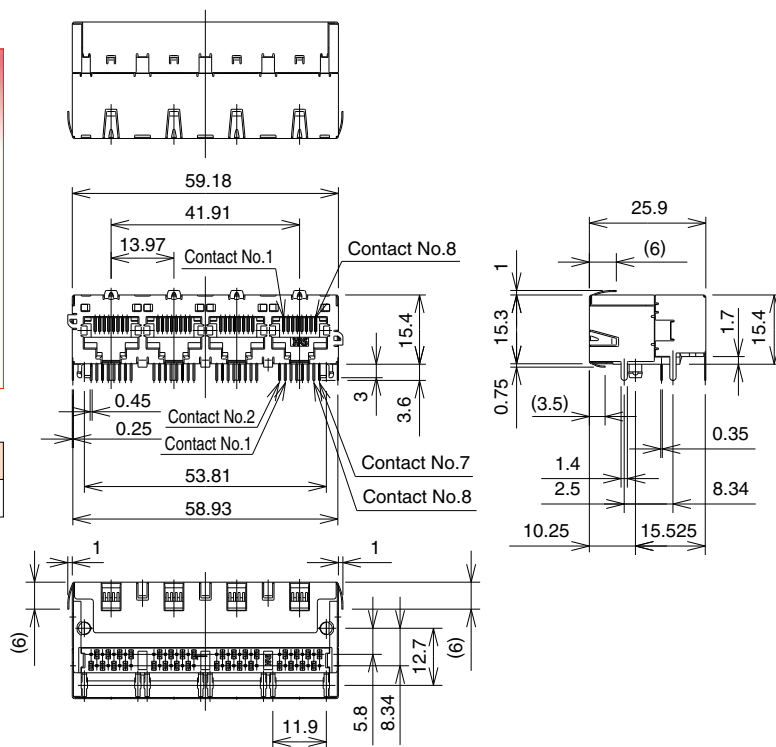

◆ Recommended PCB Mounting Patterns

LED Mount Area Dimensions

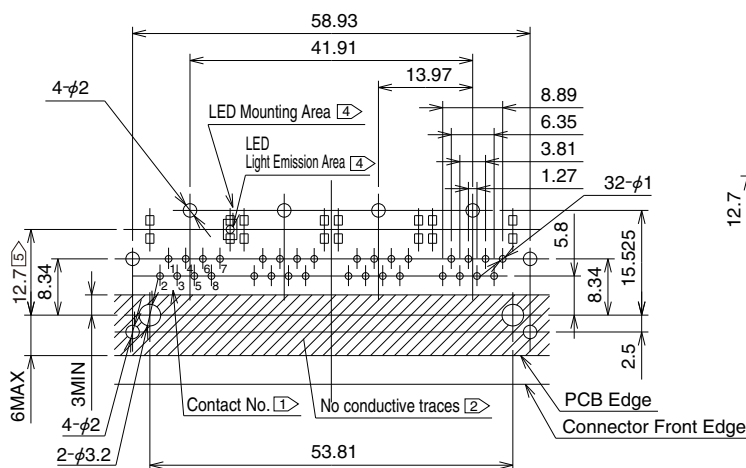

CL-220 Series

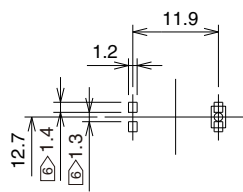

SML-010 Series

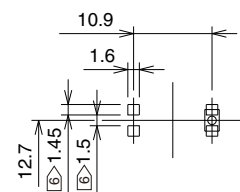

SML-020 Series

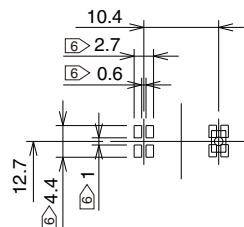

*Recommendations for PCB Design

- ① Note that the contact arrangement for contact No.1 and No.2 and No.7 and No.8 are switched.
For LED specifications, contact the LED manufacturer.
- ② Areas indicated should be free of conductive traces.
- ③ Recommended board thickness: 1.6mm.
- ④ The LED for the jack connector with built-in light pipe is mounted on the PCB. Please use the compatible LEDs shown on the table.
For LED specifications, contact the LED manufacturer.
- ⑤ Mount so that the center of the light emitting part of the LED is at the center of the dimensions indicated in the diagram.
- ⑥ Please check the latest dimension of LED pad with the corresponding LED manufacturer before designing.

④ Applicable LEDs

Series Name	Manufacturer
CL-220	Citizen Electronics Co., Ltd.
CL-221	Citizen Electronics Co., Ltd.
SML-010	Rohm Co., LTD
SML-020	Rohm Co., LTD

① Contact Arrangement

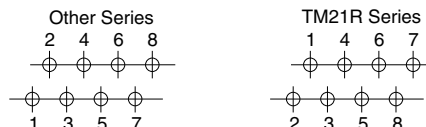

◆ Recommended Panel Cutout Diagram

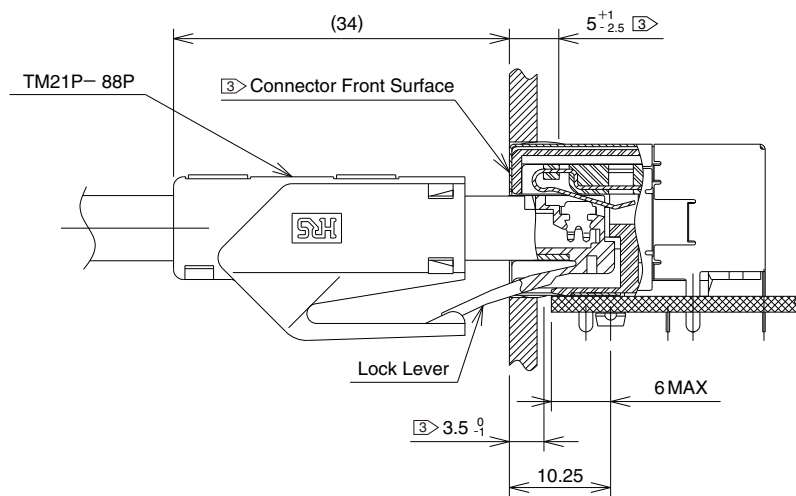
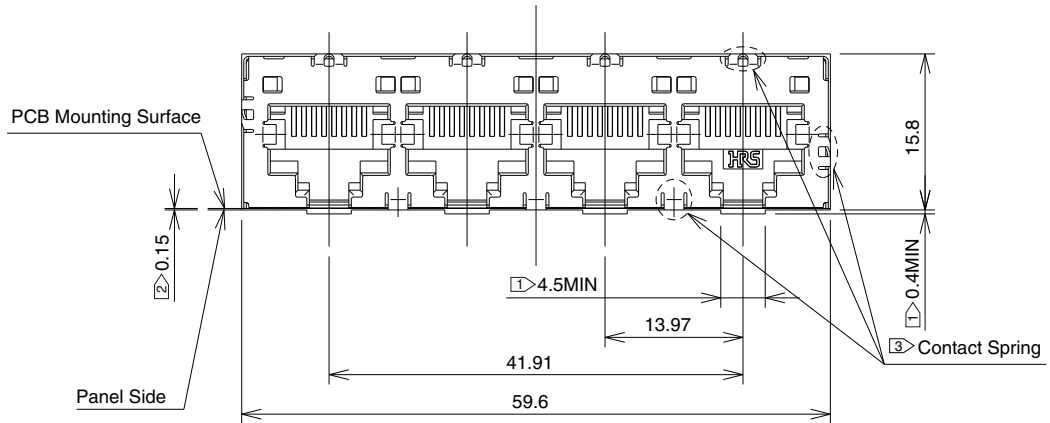

*Recommendations for Panel Design

- ① When making the panel, make a notch according to the dimensions shown as a relief for the plug lock lever.
- ② Set the panel mounting position so that the bottom surface of the panel is 0.15mm below the PCB mounting surface.
- ③ The contact position of the contact spring is $5^{+1}_{-2.5}$ (top and sides) and 3.5^0_{-1} (back side) from the front surface of the connector. Please be careful when setting the panel position.

● Usage Precautions for Built-in Light Pipe Type

IPA cleaning at room temperature is recommended for cleaning. When using a liquid-based cleaning agent, the color of the light pipe (made of polycarbonate resin) may change. Please select a cleaning agent after reviewing the table of cleaning agent effects on resin issued by cleaning agent manufacturers.

● 2 Row X 4 Ports



TM21R-5B-3232D-LP(50)

● 2 Row X 6 Ports

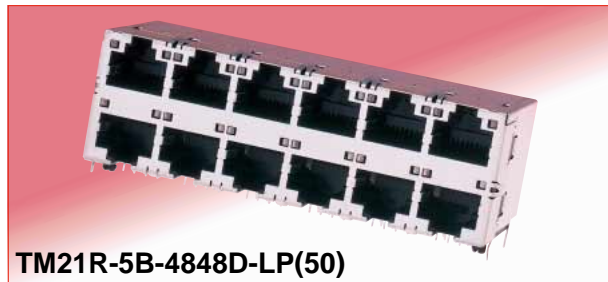

TM21R-5B-4848D-LP(50)

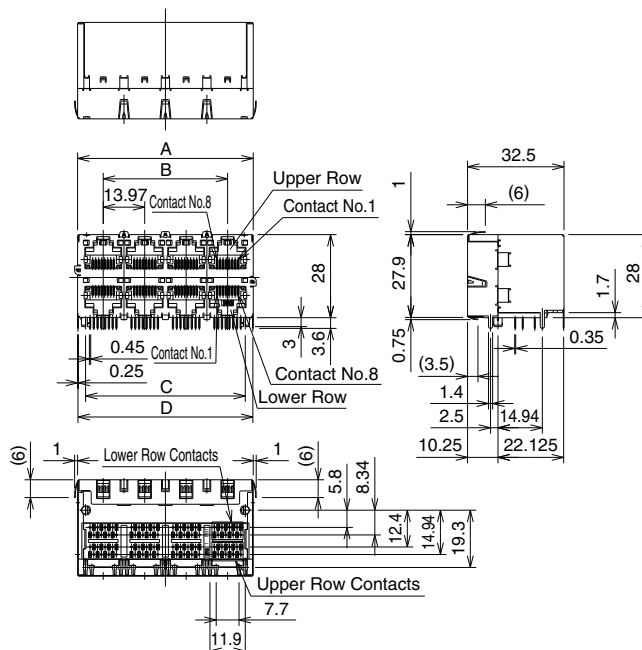

Part No.	HRS No.	A	B	C	D	RoHS
TM21R-5B-3232D-LP(50)	222-2879-1 50	59.18	41.91	53.81	58.93	YES
TM21R-5B-4848D-LP(50)	222-2885-4 50	87.12	69.85	81.75	86.87	

◆ Recommended PCB Mounting Pattern

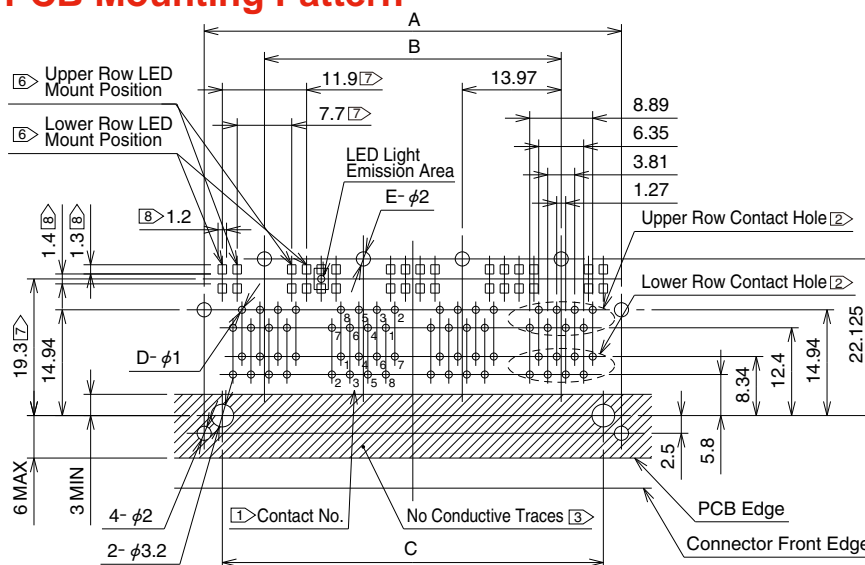

Part No.	HRS No.	A	B	C	D	E
TM21R-5B-3232D-LP(50)	222-2879-1 50	58.93	41.91	53.81	64	4
TM21R-5B-4848D-LP(50)	222-2885-4 50	86.87	69.85	81.75	96	6

*Recommendations for PCB Design

- ① Note that the contact arrangement for contact No.1 and No.2 and No.7 and No.8 are switched.
- ② The positions of the upper and lower contacts are as shown in the drawing.
- ③ Areas indicated should be free of conductive traces.
- ④ Recommended board thickness : 1.6mm.
- ⑤ The LED for the jack connector with built-in light pipe is mounted on the PCB. Please use the compatible LEDs shown on the table. For LED specifications, contact the LED manufacturer.
- ⑥ The mounting positions of the upper and lower LED are as shown in the drawing.
- ⑦ Mount so that the center of the light emitting part of the LED is at the center of the dimensions indicated in the diagram.
- ⑧ Please check the latest dimension of LED pad with the corresponding LED manufacturer before designing.

① Contact Arrangement

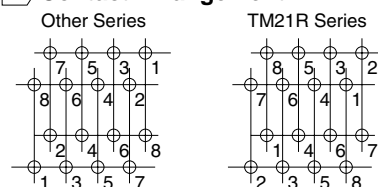

⑤ Applicable LEDs

Series Name	Manufacturer
CL-220	Citizen Electronics Co., Ltd.
CL-221	Citizen Electronics Co., Ltd.

◆ Panel Cutout

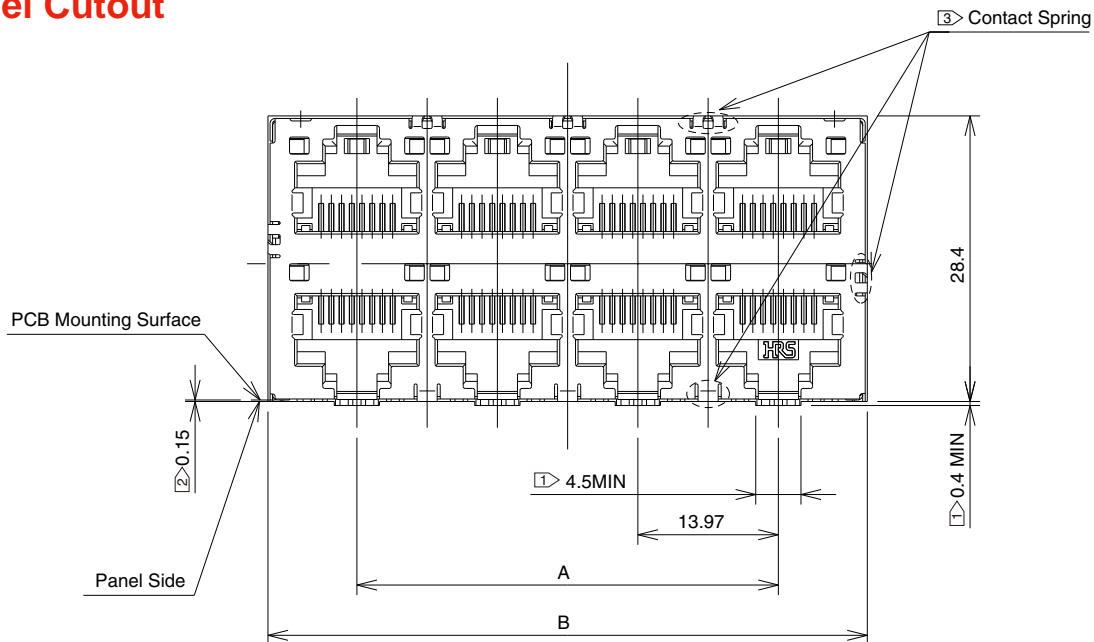

Part No.	HRS No.	A	B	RoHS
TM21R-5B-3232D-LP(50)	222-2879-1 50	41.91	59.6	YES
TM21R-5B-4848D-LP(50)	222-2885-4 50	69.85	87.54	

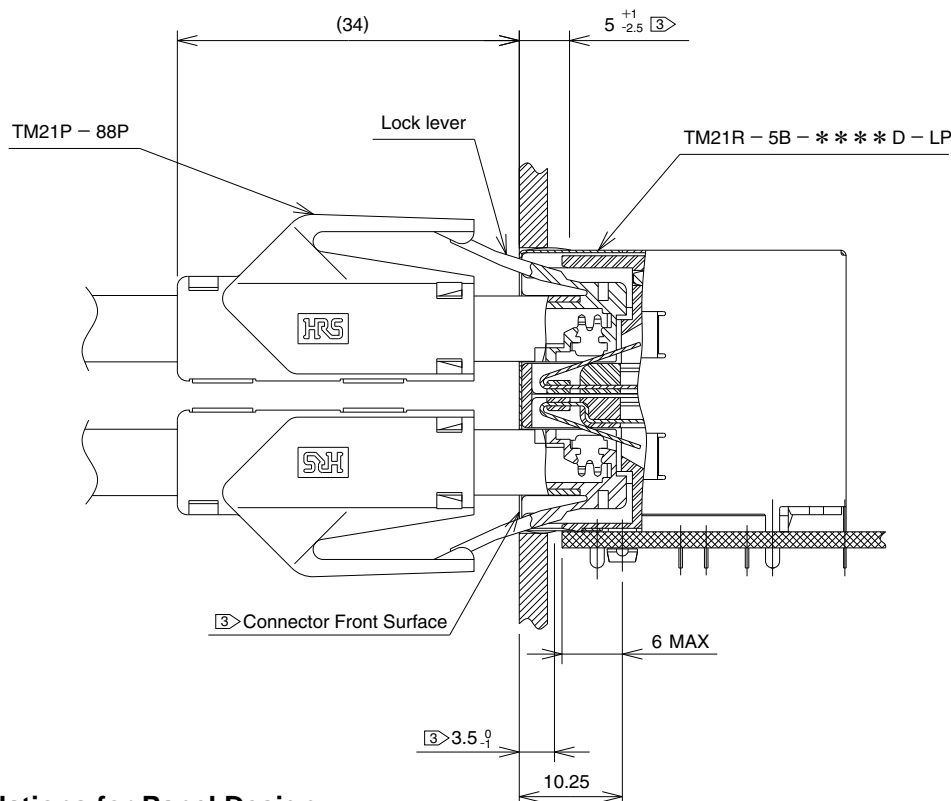

*Recommendations for Panel Design

- ① When making the panel, make a notch according to the dimensions shown as a relief for the plug lock lever.
- ② Set the panel mounting position so that the bottom surface of the panel is 0.15mm below the PCB mounting surface.
- ③ The contact position of the contact spring is $5^{+1}_{-2.5}$ (upper and side) and 3.5^0_{-1} (lower) from the front surface of the connector. Please be careful when setting the panel position.

● Usage Precautions for Built-in Light Pipe Type

IPA cleaning at room temperature is recommended for cleaning. When using a liquid-based cleaning agent, the color of the light pipe (made of polycarbonate resin) may change. Please select a cleaning agent after reviewing the table of cleaning agent effects on resin issued by cleaning agent manufacturers.

◆ Technical Documentation Cat.5e Transmission Characteristics Data

The below graph is of representative values for the various transmission characteristics for the receptacle (TM21R-5C-88P) mated with plug (TM21P-88P).

The TM21R-5C series meets the requirements for Cat.5e single transmission when used with plugs manufactured on the De-embedded method of the TIA/EIA-568-B.2 standard.

Note : This data is for the listed mated connector pair. For other combinations, please contact a Hirose Electric representative.

● Signal Attenuation

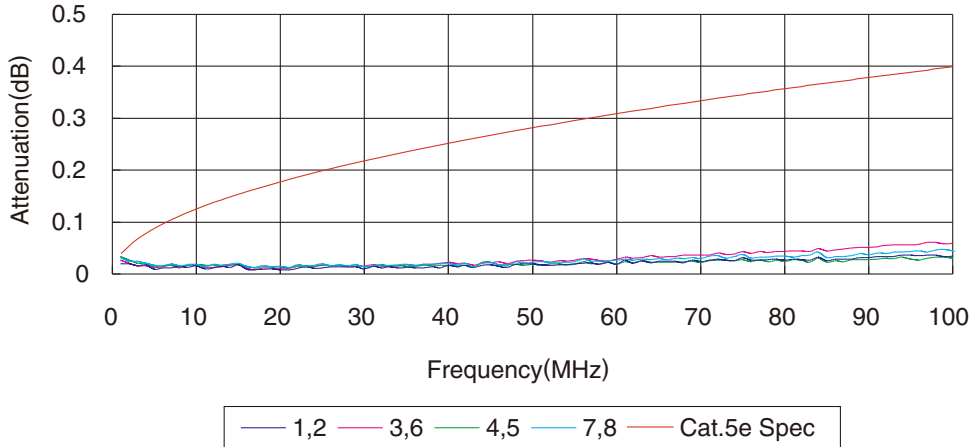

● Near-End Crosstalk (NEXT) Data

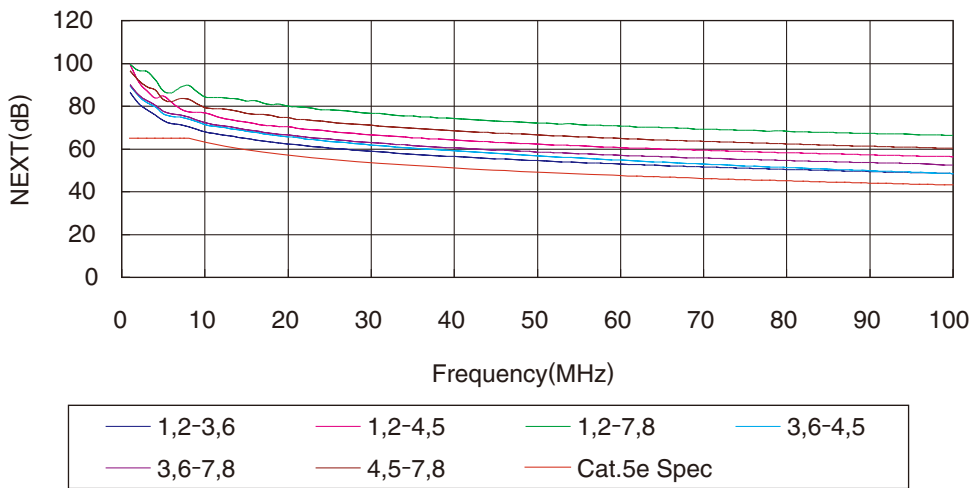

● Return Loss

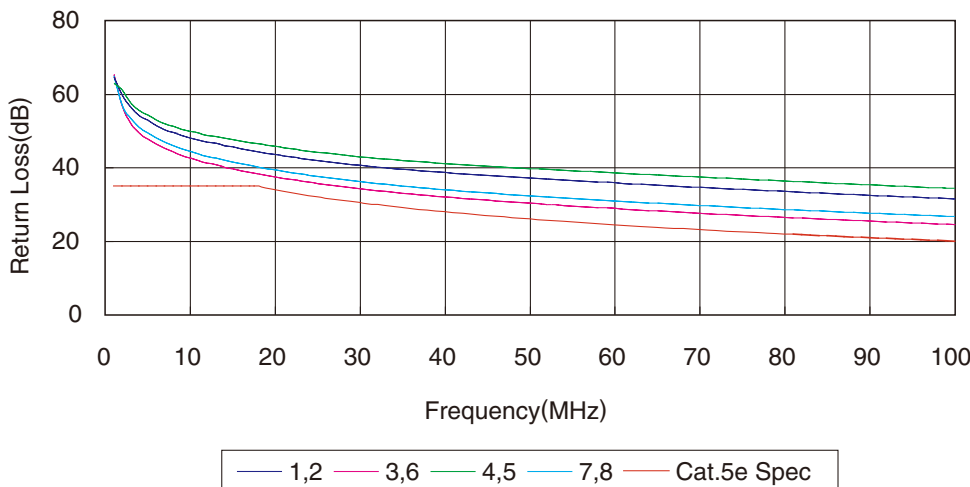

Jun.1.2024 Copyright 2024 HIROSE ELECTRIC CO., LTD. All Rights Reserved.

● Far-End Crosstalk (FEXT)

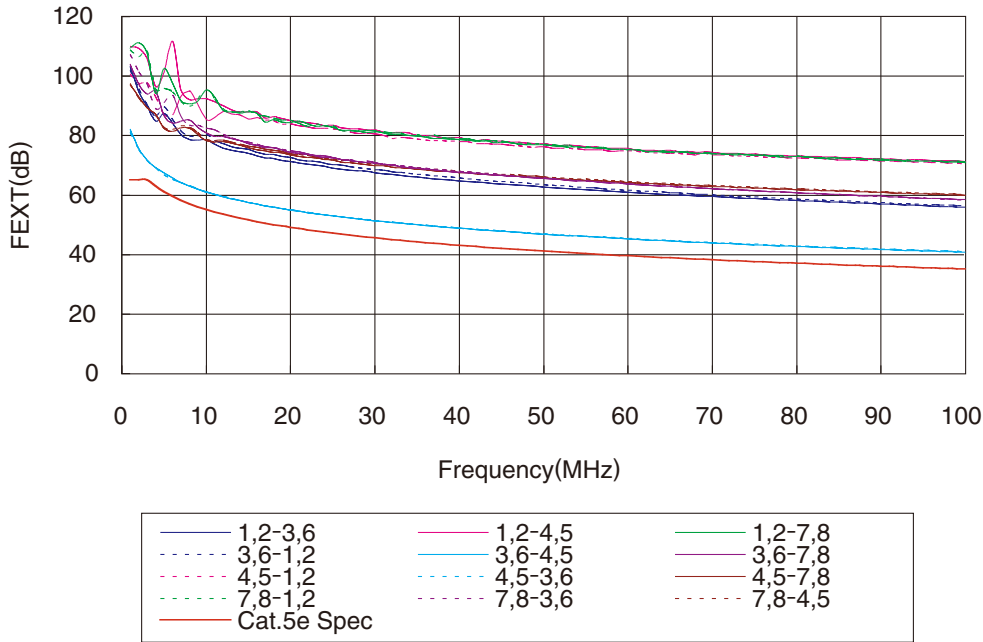

● Propagation Delay

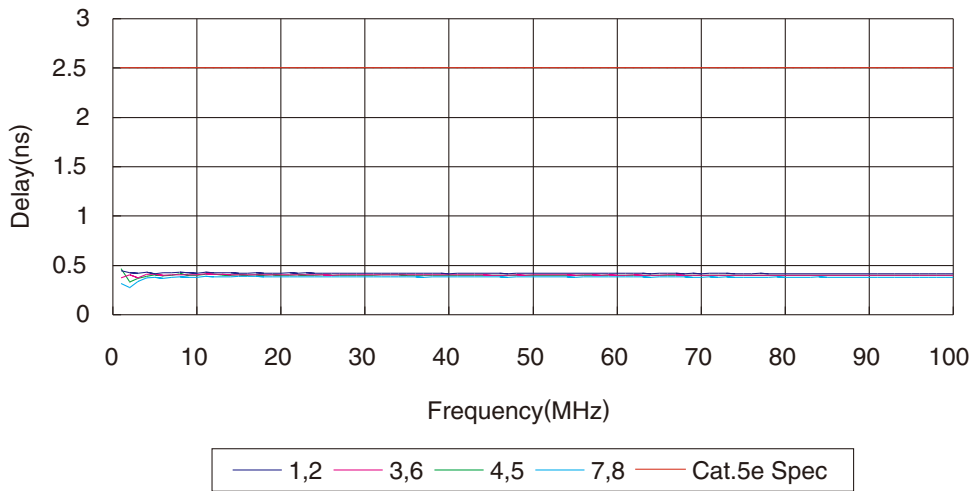

● Propagation Delay (Delay Skew)

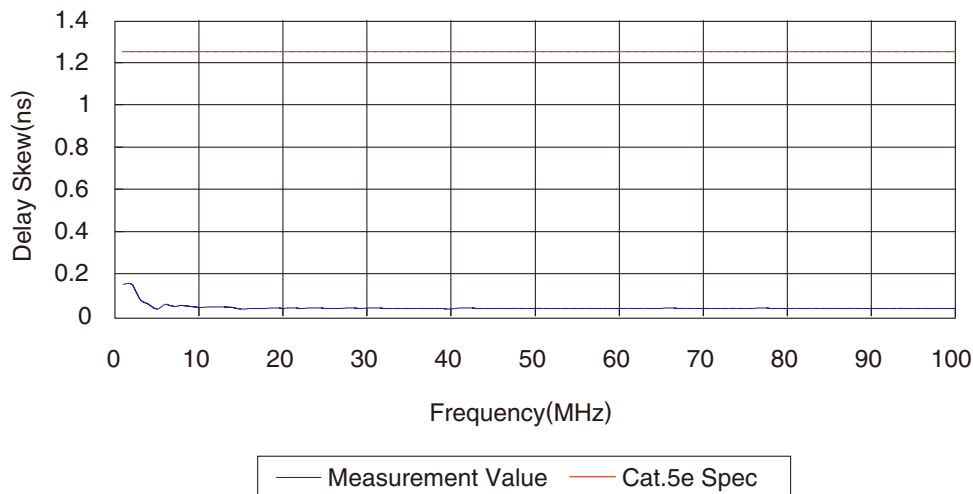

Jun.1.2024 Copyright 2024 HIROSE ELECTRIC CO., LTD. All Rights Reserved.

◆ Reference Documentation

● CAT6 Certification Received

TM21R-5C Series meets the requirements for Cat.6 single transmission when used with plugs manufactured on the de-embedded method of the TIA/EIA-568-B.2 standard under certain conditions. A certificate was issued by GHMT, an independent European testing company.



Certificate of Acceptance

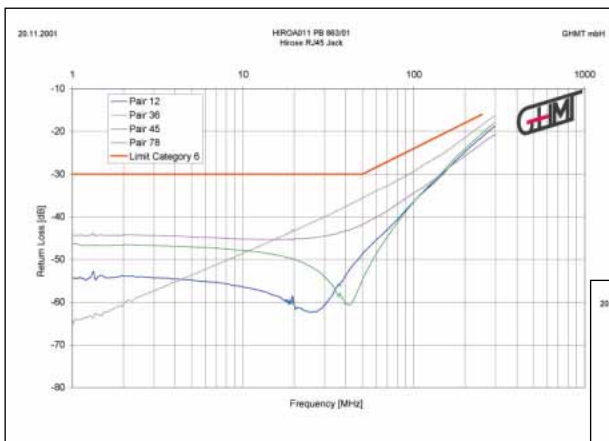

↑ Return Loss

NEXT →

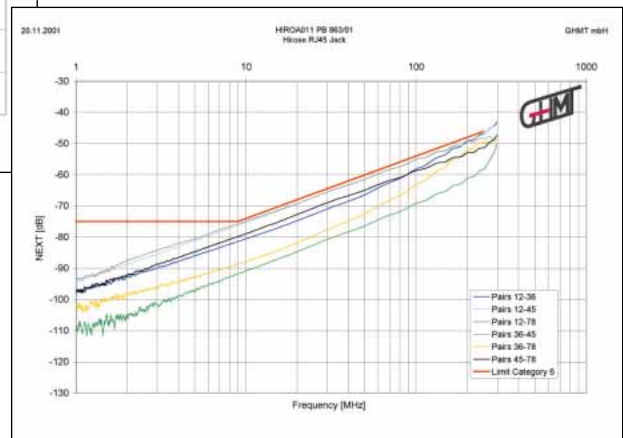

Modular Connector Guide

■ Modular Connector Contact Numbers (8pos.)

The numbers below comply with FCC standards. Please be aware of how contact numbers are decided during design.

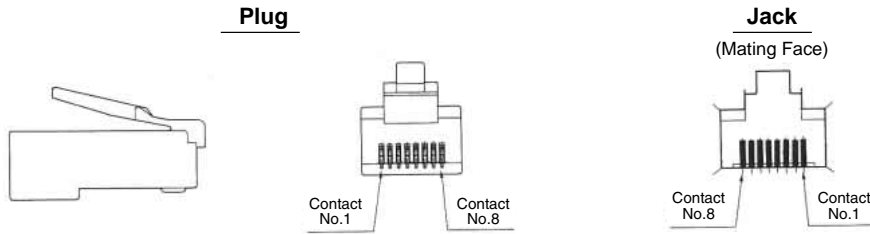

■ Plug Mating Cautions

Use only plugs that conform to FCC standards. Pay particular attention to the contact height shown to the right.

FCC Plug Dimensions

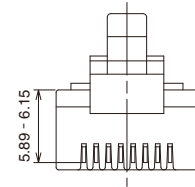

■ Mating Port Size and Number of Contacts (6pos.)

The relationship between the mating port size of the jack connector and number of contacts is shown below.



Model 66



Model 64



Model 62

Models 64 and 62 are obtained by removing 1 pin and 2 pins, respectively, from both sides of model 66. For details, please contact us for drawings because only standard models are shown in the catalogs.

■ Recommended Soldering for Modular Through-Hole Connectors

● Same for Types With/Without Built-in Light Pipe

- | | |
|---------------------------------------------|------------------------------------------|
| ● Flow solder (automatic soldering machine) | ● Hand soldering |
| Pre-heat : 90 - 130°C | Soldering iron tip temperature : 350°C |
| Pre-heat time : 120 seconds maximum | Soldering temperature : 5seconds maximum |
| Solder temperature : 240 - 260°C | Soldering iron output : 30 - 40W |
| Soldering time : 10 seconds maximum | |

Note : When soldering, do not apply excessive force to the connector terminals.

- Recommended Solder composition: Paste, 96.5%Sn/3.0%Ag/0.5%Cu

● Through-Hole Mounting Type

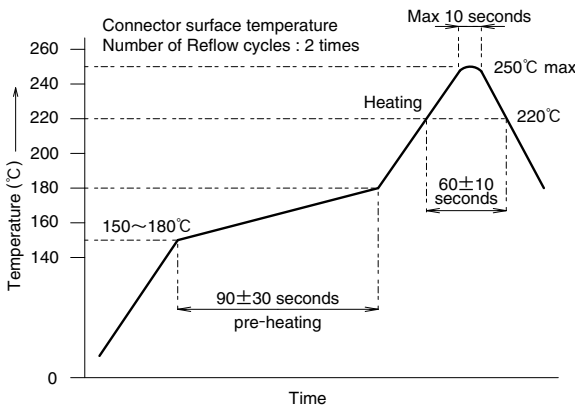

The temperature profile may vary due to external conditions such as the type of cream solder, manufacturer, and board size. Please contact the solder manufacturer for their specifications.

HIROSE ELECTRIC CO.,LTD.

2-6-3, Nakagawa Chuoh, Tsuzuki-Ku, Yokohama-Shi 224-8540, JAPAN
<https://www.hirose.com/>

Looking for pricing, stock, or lifecycle information?

Click below to explore more details on WIN SOURCE:

- ⊖ [View TM21R-5C-88\(50\) on WIN SOURCE](#)
- ⊖ [Hirose Electric Co Ltd Information](#)

Optimize Your Supply Chain with WIN SOURCE Solutions

- ✓ Global Sourcing Solution
- ✓ Obsolete Management
- ✓ Cost Control Management
- ✓ Shortage Management
- ✓ Alternative Solution
- ✓ Excess Inventory Management