



**THE DATASHEET OF
IM67D130AXTSA2**



IM67D130A

AEC-Q103 qualified high performance digital XENSIV™ MEMS microphone

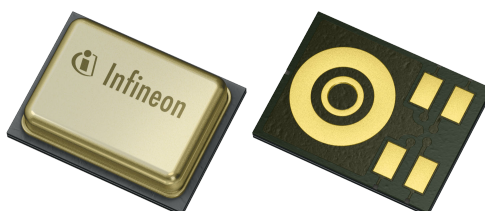

Features

- Dynamic range of 103dB for best speech performance
 - Signal to noise ratio of 67dB(A) SNR
 - <1% total harmonic distortions up to high SPL levels
 - Acoustic overload point at 130dBSPL
- Automotive qualification
- Close sensitivity and phase matching for use in arrays
- Flat frequency response with low frequency roll off and very fast analog to digital conversion speed for best ANC performance
- Digital PDM output
- Extended availability to match automotive design cycles

Product validation

Technology qualified for industrial applications.
Product qualified according to AEC-Q103-003.

Potential applications

- Hands free calling
- Emergency call
- Voice control
- Active noise cancellation / Road noise cancellation (ANC/RNC)
- Siren detection
- Road condition detection

Ordering Information

Table 1 Order information

Product name	Package	Marking	Ordering code
IM67D130A	PG-LLGA-5-4	IM67DA	SP005582032

Product description

The device is designed for applications where low self-noise (high SNR), wide dynamic range, low distortions and a high acoustic overload point is required.

Infineon's Dual Backplate MEMS technology is based on a miniaturized symmetrical microphone design, similar as utilized in studio condenser microphones and results in high linearity of the output signal within a high dynamic range. The microphone distortion does not exceed 1% even up to very high sound pressure levels. With its low equivalent noise floor the microphone is no longer the limiting factor in the audio signal chain and enables higher performance of voice recognition algorithms.

The digital microphone ASIC contains an extremely low-noise preamplifier and a high-performance sigma-delta ADC. Different power modes can be selected in order to suit specific current consumption requirements.

The tight manufacturing tolerance, combined with the fact that each device is calibrated with an advanced Infineon calibration algorithm, results in small sensitivity and phase matching tolerances. This makes it a perfect device for beam forming arrays and multi-microphone applications.

Table of contents

Table of contents

	Table of contents	3
1	Typical performance characteristics	4
2	Block diagram	5
3	Pin configuration	6
4	General product characteristics	7
4.1	Acoustic characteristics	7
4.1.1	Free field frequency response	8
4.2	Electrical parameters and characteristics	9
4.2.1	Absolute maximum ratings	9
4.2.2	Functional range	10
4.2.3	Electrical characteristics	10
4.2.4	Timing diagram	12
5	Application information	13
5.1	Use cases	13
5.2	Typical stereo application circuit	14
6	Package information	15
6.1	Package outline	15
6.2	Footprint and stencil recommendation	15
6.3	Reflow soldering and board assembly	16
6.4	Packing	17
7	Reliability specifications	19
8	Revision history	21
	Disclaimer	22

1 Typical performance characteristics

1 Typical performance characteristics

Test conditions: $V_{DD} = 1.8V$, $f_{CLK} = 3.072\text{ MHz}$, no load on DATA

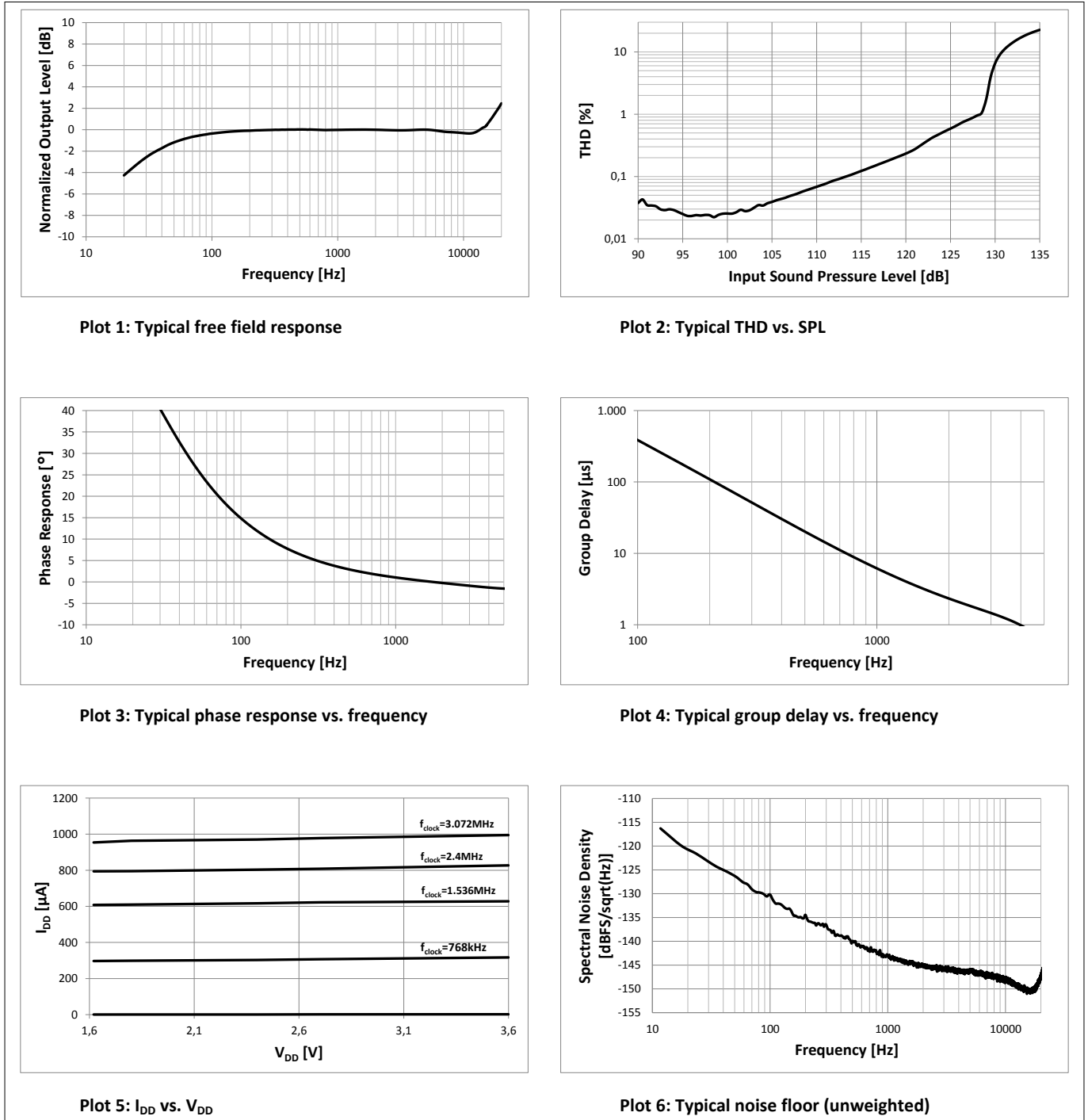

Figure 1 Typical performance characteristics

2 Block diagram

2 Block diagram

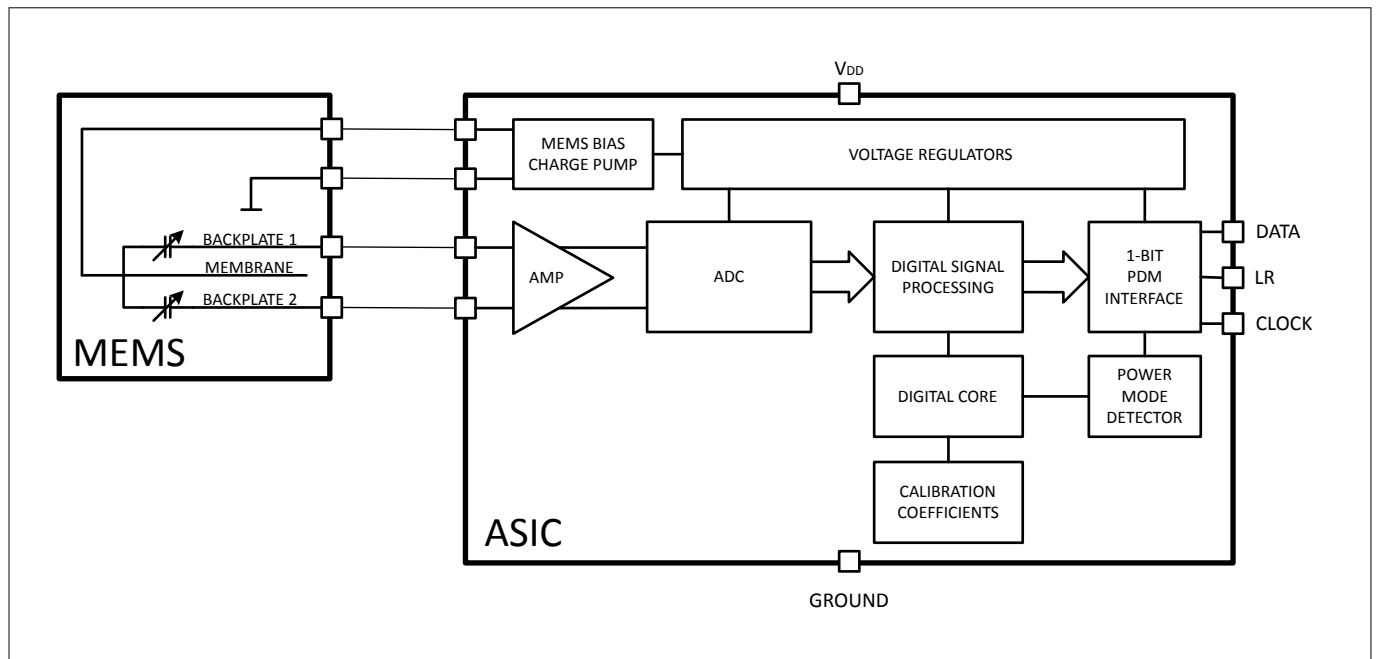

Figure 2 Block diagram

3 Pin configuration

3 Pin configuration

The figure below shows the pin configuration of the device

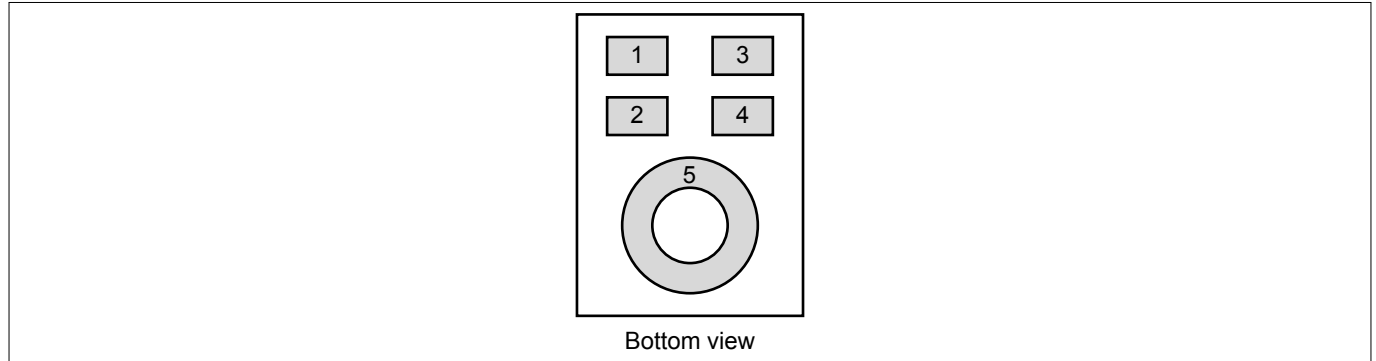

Figure 3 Pin configuration

Table 2 Pin configuration

Pin number	Name	Description
1	DATA	PDM data output
2	V _{DD}	Power supply
3	CLOCK	PDM clock input
4	LR	PDM left/right select
5	GND	Ground

4 General product characteristics

4 General product characteristics

4.1 Acoustic characteristics

Test conditions (unless otherwise specified in the table): $V_{DD} = 1.8V \pm 0.1V$, $f_{CLK} = 3.072MHz$, $T_A = 25^\circ C \pm 5^\circ C$, audio bandwidth 20Hz to 20kHz, LR pin grounded, no load on DATA, $t_{CR} = t_{CF} = 9ns$

Table 3 Acoustic specifications

Parameter	Symbol	Values			Unit	Note or condition
		Min.	Typ.	Max.		
Sensitivity	Sens	-37	-36	-35	dBFS	1kHz, 94 dB SPL, all operating modes
Acoustic Overload Point	AOP	-	130	-	dB SPL	THD = 10%, all operating modes
Signal to Noise Ratio, $f_{CLK} = 3.072MHz$	SNR	-	67	-	dB(A)	A-Weighted
Signal to Noise Ratio, $f_{CLK} = 2.4MHz$	SNR _{M2}	-	67	-	dB(A)	A-Weighted
Signal to Noise Ratio, $f_{CLK} = 1.536MHz$	SNR _{M3}	-	66	-	dB(A)	A-Weighted
Signal to Noise Ratio, $f_{CLK} = 768kHz$	SNR _{LPM}	-	64	-	dB(A)	20Hz to 8kHz bandwidth, A-Weighted
Noise Floor, $f_{CLK} = 3.072MHz$	NF	-	-103	-	dBFS(A)	A-Weighted
Noise Floor - Mode2, $f_{CLK} = 2.4MHz$	NF _{M2}	-	-103	-	dBFS(A)	A-Weighted
Noise Floor - Mode3, $f_{CLK} = 1.536MHz$	NF _{M3}	-	-102	-	dBFS(A)	A-Weighted
Noise Floor - LPM, $f_{CLK} = 768kHz$	NF _{LPM}	-	-100	-	dBFS(A)	20Hz to 8kHz bandwidth, A-Weighted
Total Harmonic Distortion, 94dB SPL	THD ₉₄	-	0.5	-	%	Measuring 2nd to 5th harmonics; 1kHz, all operating modes
Total Harmonic Distortion, 128dB SPL	THD ₁₂₈	-	1.0	-	%	Measuring 2nd to 5th harmonics; 1kHz, all operating modes
Total Harmonic Distortion, 129dB SPL	THD ₁₂₉	-	2.0	-	%	Measuring 2nd to 5th harmonics; 1kHz, all operating modes
Total Harmonic Distortion, 130dB SPL	THD ₁₃₀	-	10.0	-	%	Measuring 2nd to 5th harmonics; 1kHz, all operating modes
Low Frequency Cutoff Point	f_{C_LP}	-	28	-	Hz	-3dB point relative to 1kHz

(table continues...)

4 General product characteristics

Table 3 (continued) Acoustic specifications

Parameter	Symbol	Values			Unit	Note or condition
		Min.	Typ.	Max.		
Group Delay, 250Hz	t_{gd_250}	-	70	-	μs	
Group Delay, 600Hz	t_{gd_600}	-	15	-	μs	
Group Delay, 1kHz	t_{gd_1000}	-	6	-	μs	
Group Delay, 4kHz	t_{gd_4000}	-	1	-	μs	
Phase Response, 75Hz	Φ_{75}	-	19	-	$^{\circ}$	
Phase Response, 1kHz	Φ_{1000}	-	2	-	$^{\circ}$	
Phase Response, 3kHz	Φ_{3000}	-	-1	-	$^{\circ}$	

Directivity: The device has an omnidirectional pickup pattern.

Polarity: The device has a positive polarity. Positive pressure increases density of 1's, negative pressure decreases density of 1's in data output)

4.1.1 Free field frequency response

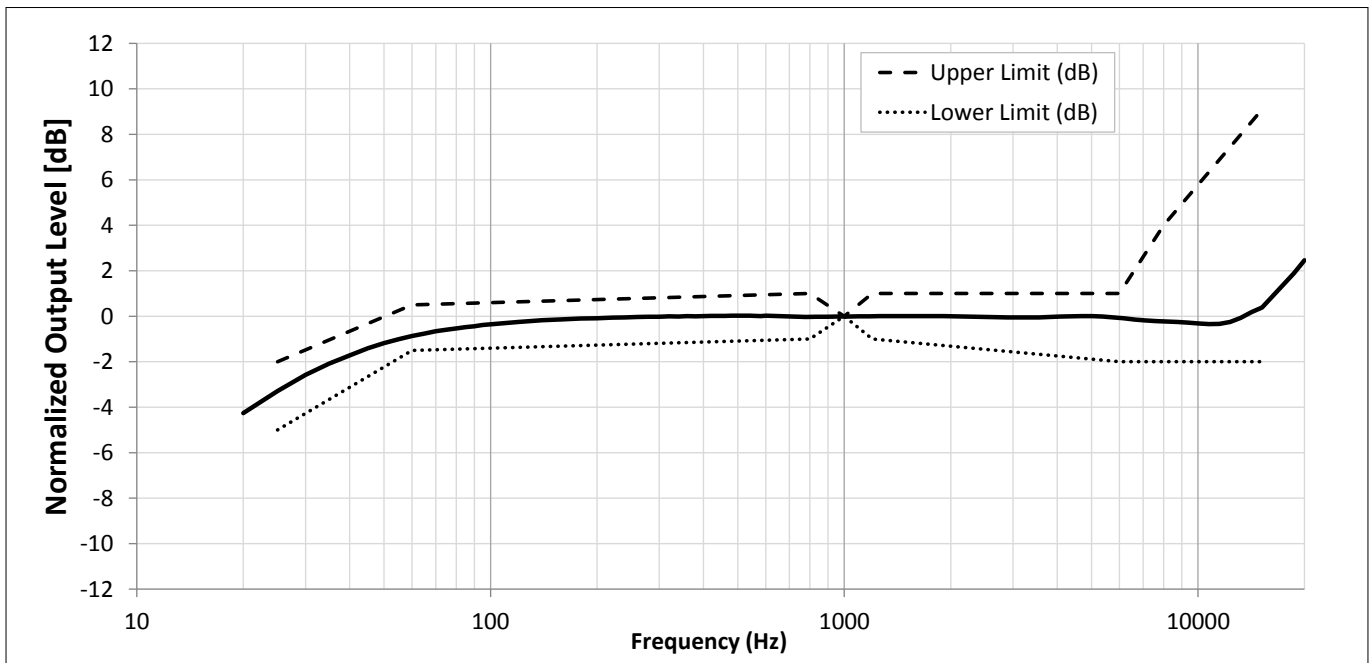

Figure 4 Free field frequency response

4 General product characteristics

Table 4 Free field frequency response, normalized to 1kHz sensitivity value

Frequency (Hz)	Upper Limit (dB)	Lower Limit (dB)
25	-2	-5
60	+0.5	-1.5
800	+1	-1
1000	0	0
1200	+1	-1
6000	+1	-2
8000	+4	-2
15000	+9	-2

4.2 Electrical parameters and characteristics

4.2.1 Absolute maximum ratings

Table 5 Absolute maximum ratings

Parameter	Symbol	Values			Unit	Note or condition
		Min.	Typ.	Max.		
Voltage on any Pin	V_{max}	-	-	4	V	
Storage Temperature	T_S	-40	-	125	°C	

Attention: Stresses above those listed under “Absolute maximum ratings” may cause permanent damage to the device. This is a stress rating only and functional operation of the device at these or any other conditions above those indicated in the section “Functional range” of this datasheet is not implied. Furthermore, only single error cases are assumed. More than one stress/error case may also damage the device.

Exposure to absolute maximum rating conditions for extended periods may affect device reliability. During absolute maximum rating overload conditions the voltage on V_{DD} pins with respect to ground (GND) must not exceed the values defined by the absolute maximum ratings. Lifetime statements are an anticipation based on an extrapolation of Infineon’s qualification test results. The actual lifetime of a component depends on its form of application and type of use etc. and may deviate from such statement. Lifetime statements shall in no event extend the agreed warranty period.

4 General product characteristics

4.2.2 Functional range

Table 6 Functional range

Parameter	Symbol	Values			Unit	Note or condition
		Min.	Typ.	Max.		
Supply Voltage	V_{DD}	1.62	-	3.60	V	A 100nF bypass capacitor should be placed close to the microphone's V_{DD} pin to ensure best SNR performance
Ambient operating temperature	T_A	-40	-	+105	°C	
Clock Frequency Range, HPM	f_{CLK_HPM}	2.9	3.072	3.3	MHz	
Clock Frequency Range, Mode2	f_{CLK_M2}	2.1	2.4	2.65	MHz	
Clock Frequency Range, Mode3	f_{CLK_M3}	1.05	1.536	1.9	MHz	
Clock Frequency Range, LPM	f_{CLK_LPM}	400	768	950	kHz	
Clock Frequency Range, Standby mode	f_{CLK_sb}	-	-	250	kHz	DATA = high-Z
PDM Clock Frequency	f_{CLK}	0.4	-	3.30	MHz	
VDD Ramp-up Time	V_{DD_ru}	-	-	50	ms	Time until $V_{DD} \geq V_{DD_min}$
Clock Duty Cycle	CLK_{duty}	40	-	60	%	$f_{CLK} < 2.65\text{MHz}$
Clock Duty Cycle, High performance mode	CLK_{duty_HPM}	48	-	52	%	$f_{CLK} \geq 2.9\text{MHz}$
Clock Rise/Fall Time	t_{CR} / t_{CF}	-	-	13	ns	
Input Logic Low Level	V_{IL}	-0.3	-	$0.35 \times V_{DD}$	V	
Input Logic High Level	V_{IH}	$0.65 \times V_{DD}$	-	$V_{DD} + 0.3$	V	
Output Load Capacitance on DATA	C_{load}	-	-	200	pF	

4.2.3 Electrical characteristics

Test conditions (unless otherwise specified in the table): $V_{DD} = 1.8\text{V} \pm 0.1\text{V}$, $T_A = 25^\circ\text{C} \pm 5^\circ\text{C}$

4 General product characteristics

Table 7 General electrical characteristics

Parameter	Symbol	Values			Unit	Note or condition
		Min.	Typ.	Max.		
Current Consumption, HPM	I_{DD_HPM}	-	980	1300	μA	No load on DATA
Current Consumption, Mode2	I_{DD_M2}	-	800	1050	μA	No load on DATA
Current Consumption, Mode3	I_{DD_M3}	-	620	800	μA	No load on DATA
Current Consumption, LPM	I_{DD_LPM}	-	300	380	μA	No load on DATA
Current Consumption, Standby mode	$I_{standby}$	-	25	50	μA	No load on DATA
Current Consumption, Clock off mode	I_{clock_off}	-	-	1	μA	CLOCK pulled low
Short Circuit Current	I_{short}	1	-	20	mA	Grounded DATA pin
Power Supply Rejection	PSR_{1k_NM}	-	-80	-	dBFS	100mV _{pp} sine wave on V _{DD} swept from 200Hz to 20kHz
Power Supply Rejection	PSR_{217_NM}	-	-86	-	dBFS(A)	100mV _{rms} , 217Hz square wave on V _{DD} , A-weighted
Startup Time, ± 0.5 dB sensitivity accuracy	$t_{start-up}$	-	-	20	ms	Time to start up in all operating modes after V _{DD_min} and CLOCK have been applied
Startup Time, ± 0.2 dB sensitivity accuracy	$t_{start-up_HP}$	-	-	50	ms	Time to start up in all operating modes after V _{DD_min} and CLOCK have been applied
Mode Switch Time, ± 0.5 dB sensitivity accuracy	$t_{mode-switch}$	-	-	20	ms	Time to switch between operating modes. V _{DD} remains on during the mode switch
Mode Switch Time, ± 0.2 dB sensitivity accuracy	$t_{mode-switch_HP}$	-	-	50	ms	Time to switch between operating modes. V _{DD} remains on during the mode switch
Hysteresis Width	V_{hys}	$0.1 \times V_{DD}$	-	$0.29 \times V_{DD}$	V	
Output Logic Low Level	V_{OL}	-	-	$0.3 \times V_{DD}$	V	$I_{out} = 2mA$
Output Logic High Level	V_{OH}	$0.7 \times V_{DD}$	-	-	V	$I_{out} = 2mA$

(table continues...)

4 General product characteristics

Table 7 (continued) General electrical characteristics

Parameter	Symbol	Values			Unit	Note or condition
		Min.	Typ.	Max.		
Delay Time for DATA Driven	t_{DD}	40	-	80	ns	Delay time from CLOCK edge ($0.5xV_{DD}$) to DATA driven
Delay Time for DATA High-Z	t_{HZ}	5	-	30	ns	Delay time from CLOCK edge ($0.5xV_{DD}$) to DATA high impedance state ¹⁾
Delay Time for DATA Valid	t_{DV}	-	-	100	ns	Delay time from CLOCK edge ($0.5xV_{DD}$) to DATA valid ($<0.3xV_{DD}$ or $>0.7xV_{DD}$) ²⁾

4.2.4 Timing diagram

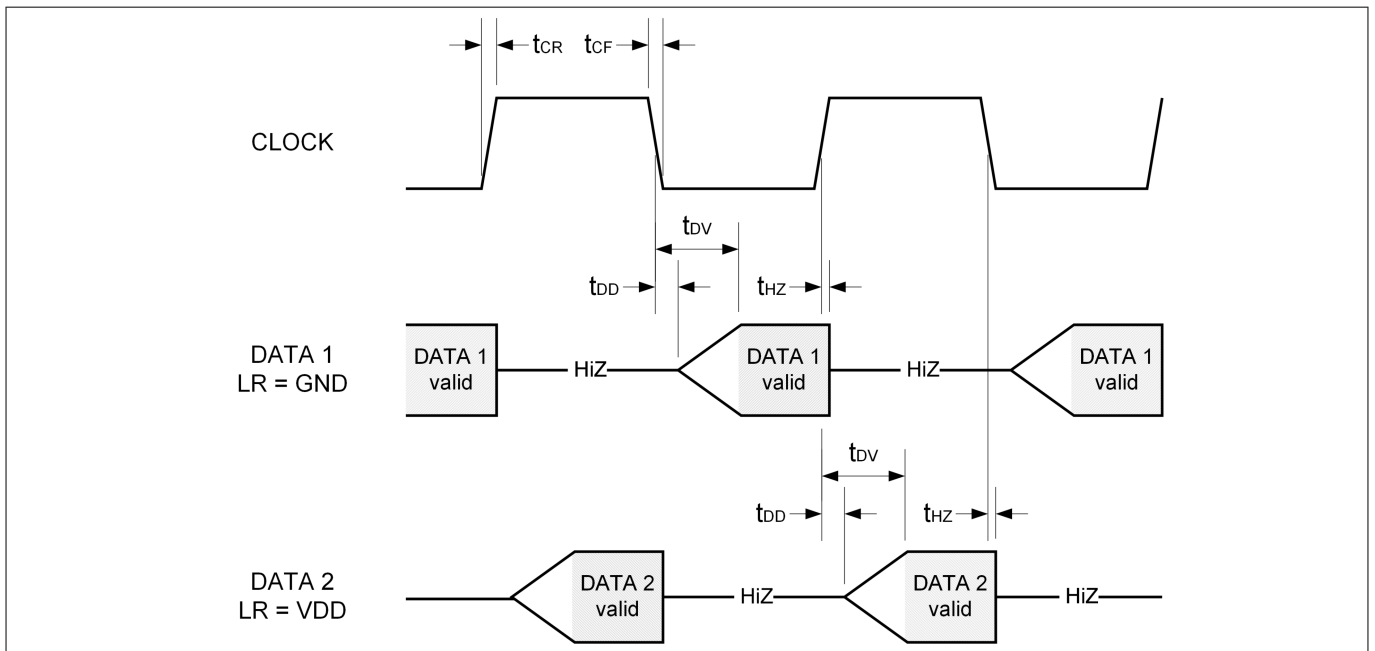

Figure 5 Timing diagram

¹ t_{HZ} is dependent upon C_{load}
² Load on DATA: $C_{load} = 100pF$, $R_{load} = 100k\Omega$

5 Application information**5 Application information****5.1 Use cases**

- Total Harmonic Distortion (THD) below 1% up to high sound pressure levels (SPL)
 - Clear speech in a wide dynamic range
 - Reliable voice commands during high background noise
 - Effective active noise cancellation even close to loud noise source
- High Signal to Noise Ratio (SNR)
 - Far field audio signal pick-up
 - Low volume audio and whispered voice capturing
 - Good performance with speech recognition algorithms
 - Microphone noise is no longer limiting the audio chain
- Close sensitivity and phase matching
 - Good performance in audio beamforming
 - High and precise attenuation of background noise
 - Full utilization of voice algorithms capability
- Flat frequency response with low f_{c_LP} (low frequency cutoff point) and small group delay
 - Good performance in active noise cancellation systems
 - Excellent speech quality over full frequency range
- Power optimized modes
 - Low current consumption for always on applications
 - Long operating time of battery powered devices

5 Application information

5.2 Typical stereo application circuit

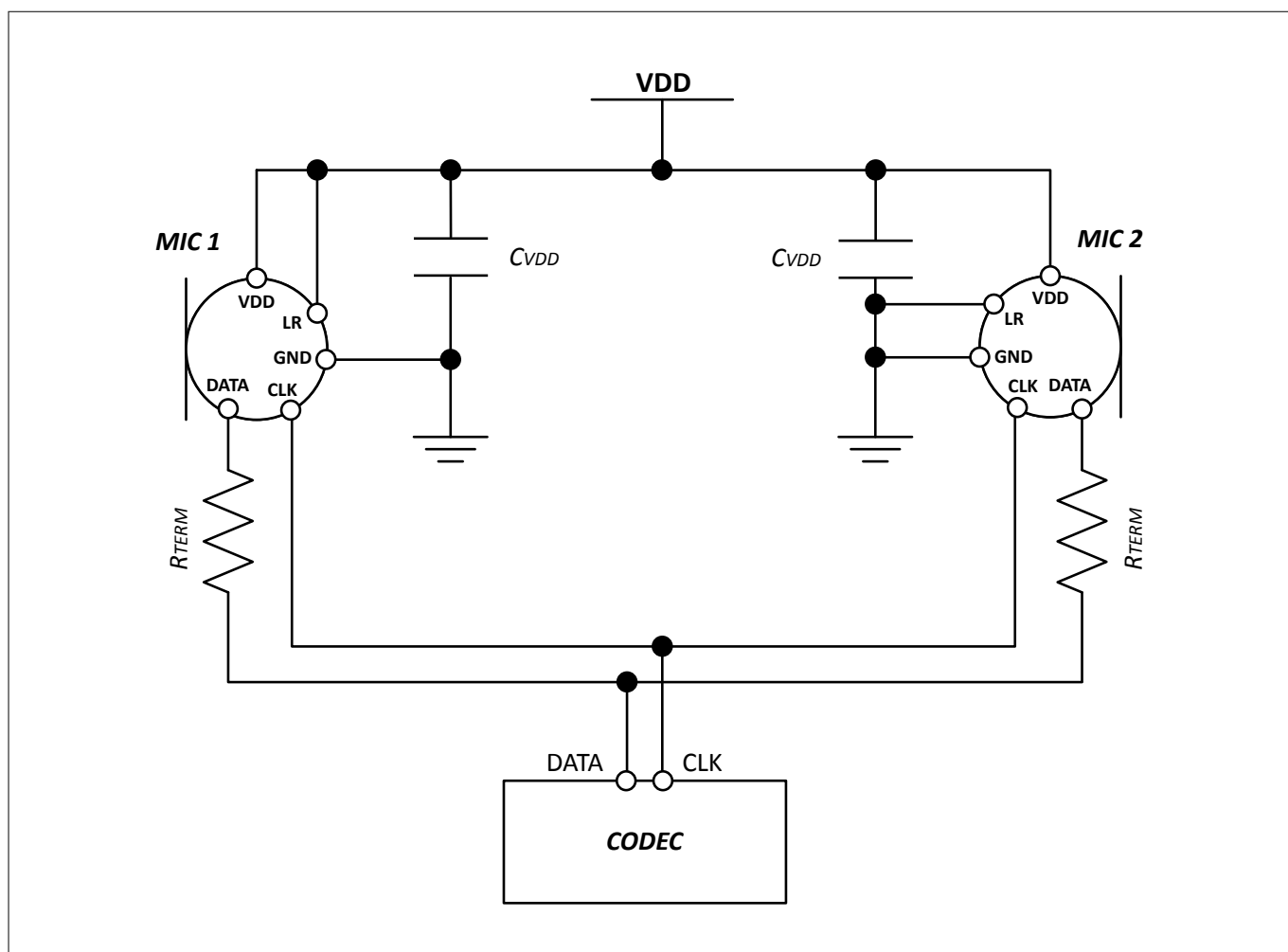

Figure 6 Typical stereo application circuit

Note: For best performance it is strongly recommended to place a 100nF ($C_{VDD_typical}$) capacitor between V_{DD} and ground. The capacitor should be placed as close to V_{DD} as possible. A termination resistor (R_{TERM}) of about 100Ω may be added to reduce the ringing and overshoot on the output signal.

6 Package information

6 Package information

This product is compliant to RoHS

6.1 Package outline

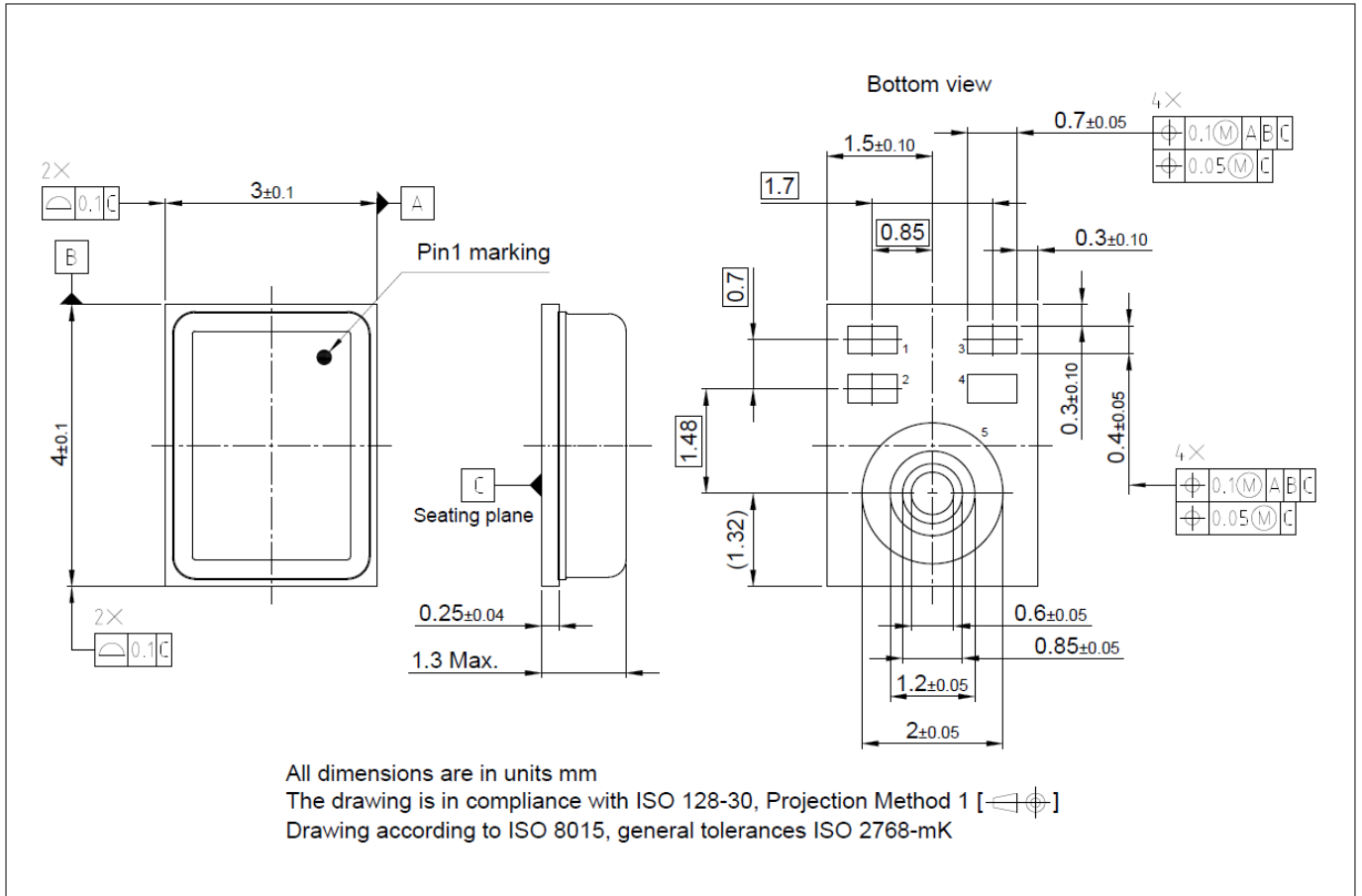

Figure 7 Package outline drawing

6.2 Footprint and stencil recommendation

The acoustic port hole diameter in the PCB should be larger than the acoustic port hole diameter of the MEMS microphone to ensure optimal performance. A PCB sound port size of radius 0.4 mm (diameter 0.8mm) is recommended.

The board pad and stencil aperture recommendations shown in the figure below are based on Solder Mask Defined (SMD) pads. The specific design rules of the board manufacturer should be considered for individual design optimizations or adaptations.

6 Package information

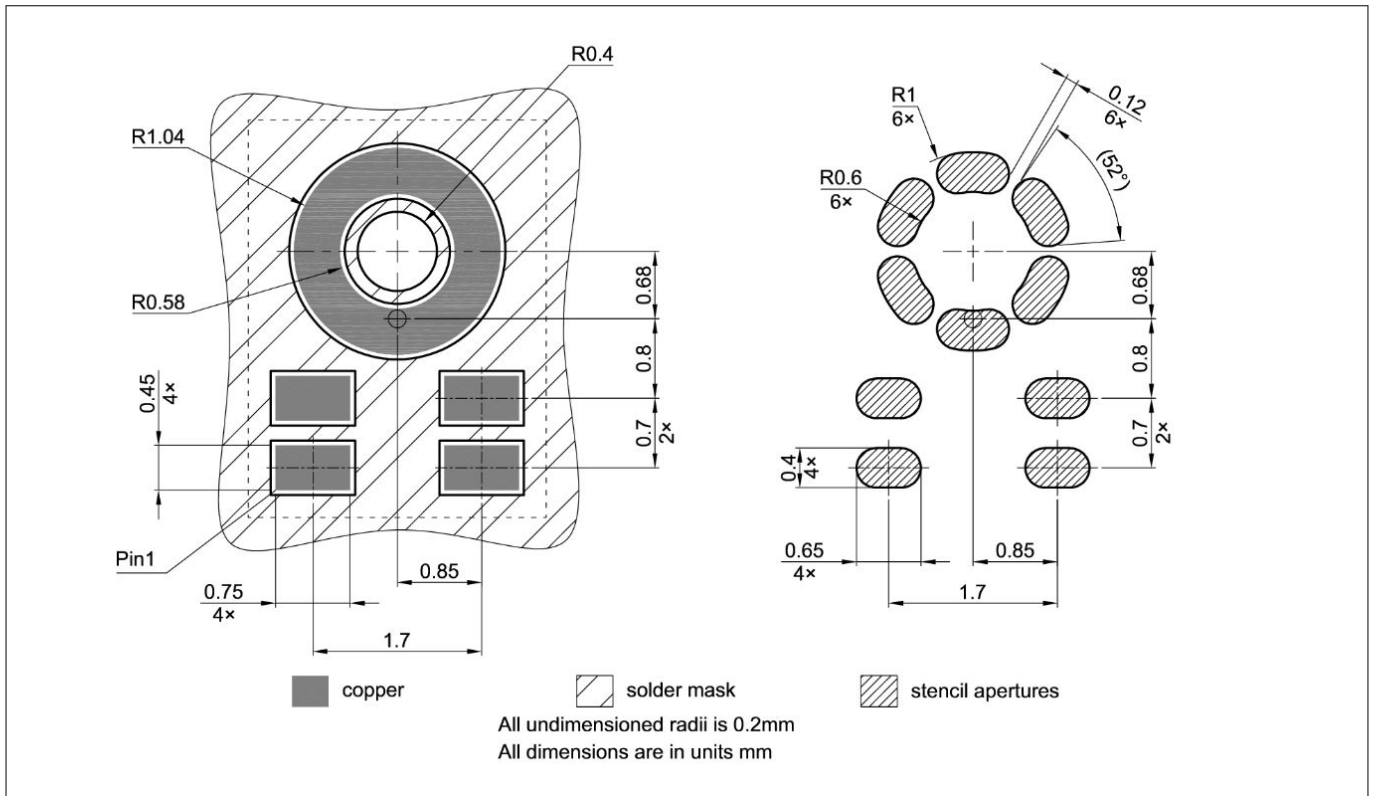

Figure 8 Footprint and stencil recommendation

6.3 Reflow soldering and board assembly

Infineon MEMS microphones are qualified in accordance with the IPC/JEDEC J-STD-020D-01. The moisture sensitivity level of MEMS microphones is rated as MSL1. For PCB assembly of the MEMS microphone the widely used reflow soldering using a forced convection oven is recommended.

The soldering profile should be in accordance with the recommendations of the solder paste manufacturer to reach an optimal solder joint quality. The reflow profile shown in the figure below is recommended for board manufacturing with Infineon MEMS microphones.

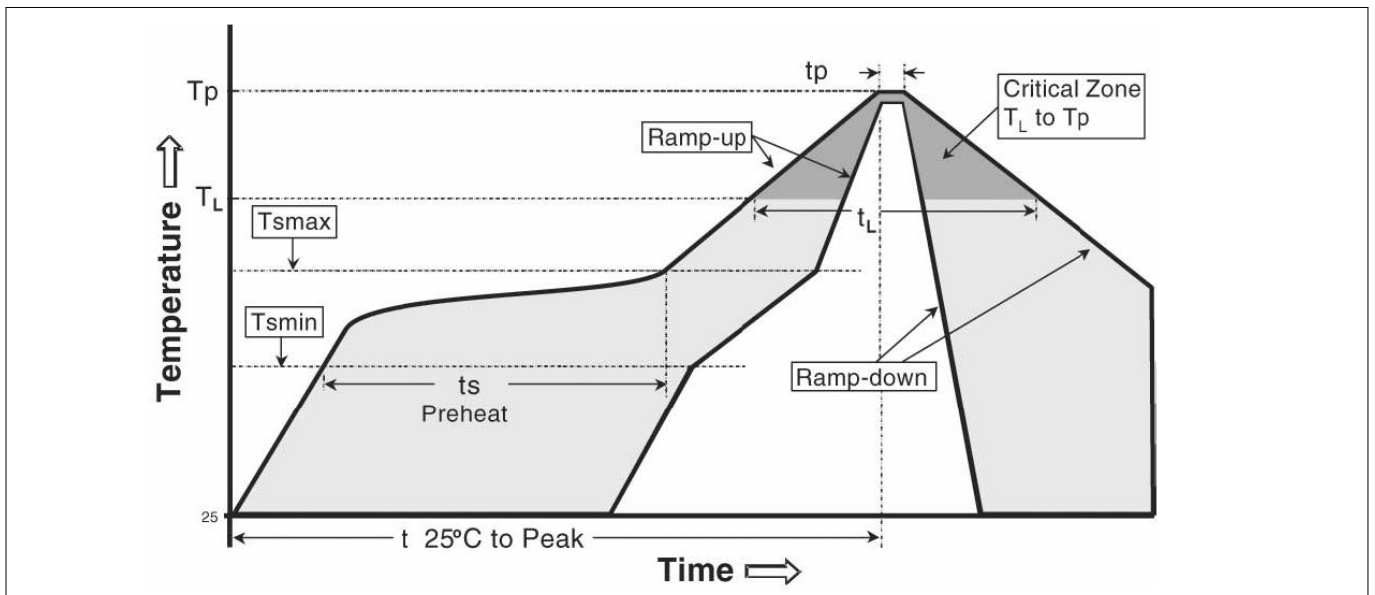

Figure 9 Recommended reflow profile

6 Package information

Table 8 Reflow profile limits

Profile feature	Symbol	Pb-free assembly	Sn-Pb Eutectic assembly
Preheat temperature min.	T_{smin}	150°C	100°C
Preheat temperature max.	T_{smax}	200°C	150°C
Preheat time (T_{smin} to T_{smax})	t_s	60-120 seconds	60-120 seconds
Ramp-up rate (T_L to T_P)		3°C/second max.	3°C/second max.
Liquidous temperature	T_L	217°C	183°C
Time maintained above T_L	t_L	60-150 seconds	60-150 seconds
Peak temperature	T_P	260°C +0°C/-5°C	235°C +0°C/-5°C
Time within 5°C of actual peak temperature (see note below)	t_p	20-40 seconds	10-30 seconds
Ramp-down rate		6°C/second max.	6°C/second max.
Time 25°C to peak temperature	t	8 minutes max.	6 minutes max.

Note: Tolerance for peak profile temperature (T_p) is defined as a supplier minimum and a user maximum.

The MEMS microphones can be handled using industry standard pick and place equipment. Care should be taken to avoid damage to the microphone structure as follows:

- Do not pick the microphone with vacuum tools which make contact with the microphone acoustic port hole.
- The microphone acoustic port hole should not be exposed to vacuum. This can destroy or damage the MEMS.
- Do not blow air into the microphone acoustic port hole. If an air blow cleaning process is used, the port hole must be sealed to prevent particle contamination.
- It is recommended to perform the PCB assembly in a clean room environment in order to avoid microphone contamination.
- Air blow and ultrasonic cleaning procedures shall not be applied to MEMS Microphones. A no-clean paste is recommended for the assembly to avoid subsequent cleaning steps. The microphone MEMS can be severely damaged by cleaning substances.
- To prevent the blocking or partial blocking of the sound port during PCB assembly, it is recommended to cover the sound port with protective tape during PCB sawing or system assembly.
- Do not use excessive force to place the microphone on the PCB. The use of industry standard pick and place tools is recommended in order to limit the mechanical force exerted on the package.

Note: For further information please consult the "General recommendation for assembly of Infineon packages" document, which is available on the Infineon Technologies [web page](#).

6.4 Packing

For shipping and assembly the Infineon microphones are packed in product specific tape-and-reel carriers. A detailed drawing of the carrier can be seen in the figure below.

6 Package information

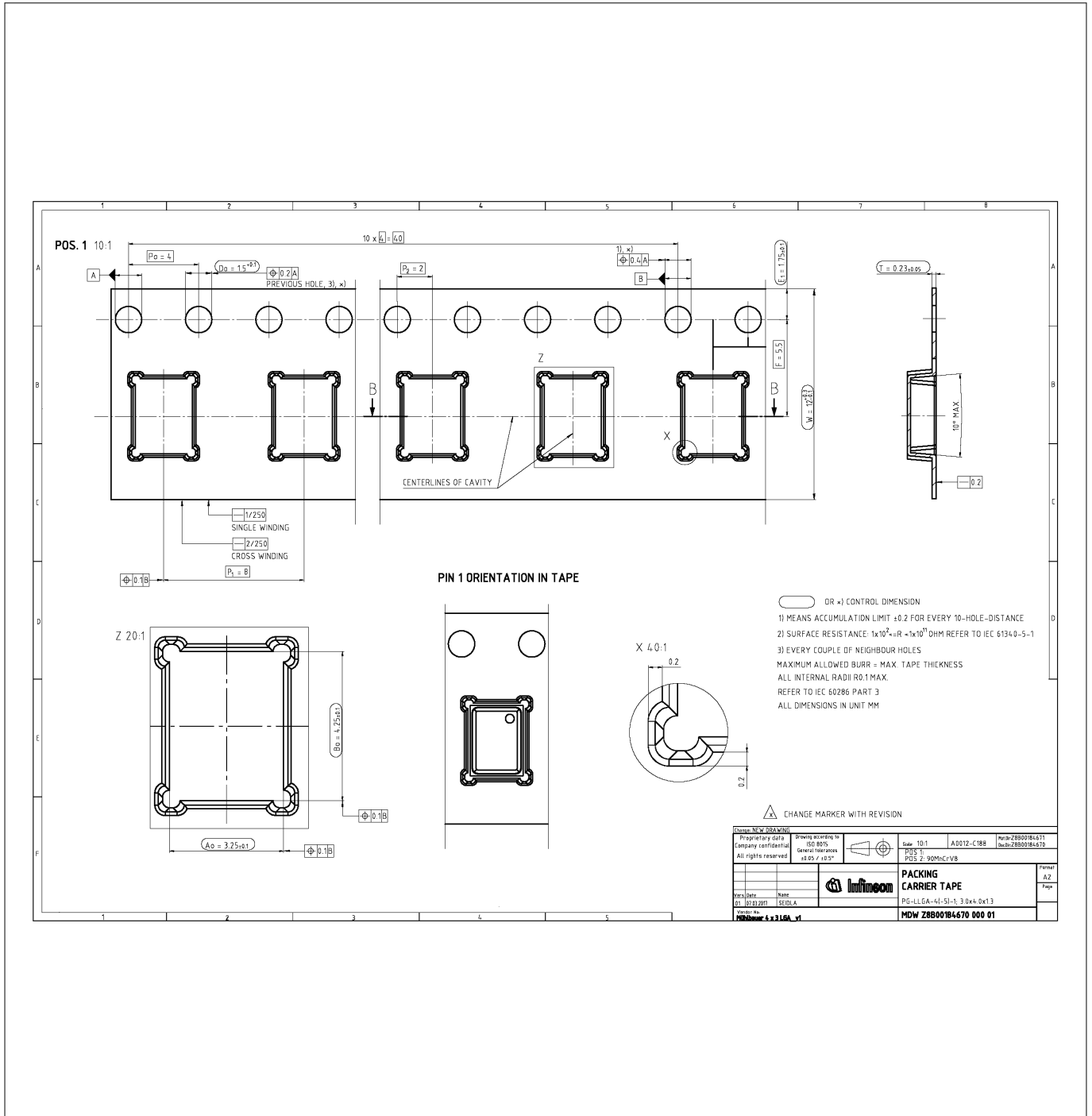

Figure 10 Tape dimensions

More information can be found on the Infineon website:

<https://www.infineon.com/cms/en/product/packages/PG-LLGA/PG-LLGA-5-4/>

7 Reliability specifications

7 Reliability specifications

The microphone sensitivity after stress and over temperature does not deviate by no more than +/- 3dB from the initial value.

Table 9 Qualification tests according to AEC-Q103-003

Test	Stress condition	Standard
Temperature humidity bias	$T_A = +85^\circ\text{C}$, R.H. = 85%, $V_{DD} = 3.6\text{V}$, cyclical bias, 1000 hours	AEC Q100 Rev.H.
Temperature humidity storage	$T_A = +85^\circ\text{C}$, R.H = 85%, 1000 hours	AEC Q100 Rev.H.
Temperature cycling	$T_A = -55^\circ\text{C} \dots +125^\circ\text{C}$, 30 min cycle time, 1000cycles	AEC Q100 Rev.H.
High temperature storage life	$T_A = +125^\circ\text{C}$, 1000 hours	AEC Q100 Rev.H.
High temperature operating life	$T_A = +125^\circ\text{C}$, $V_{DD} = 3.6\text{V}$, 1000 hours	AEC Q100 Rev.H.
Early life failure rate	$T_A = +125^\circ\text{C}$, $V_{DD} = 2.5\text{V}$, 48 hours Read out after stress at room temperature	JESD22-A108
Wire bond shear	Bump shear test	AEC Q100-001
Wire bond pull	-	MIL-STD883 Method 2011
Solderability	-	JESD22-B102
Physical dimensions	-	JESD22-B100 and B108
Solder ball shear	-	AEC Q103-003
Mechanical shock	3 pulses, 0.5msec duration, 10,000g peak acceleration in x,y and z planes	JESD22-B104
Variable frequency vibration	20Hz to 2kHz to 20Hz (logarithmic variation) in 12 minutes, 4x in each orientation, 20g peak acceleration	JESD22-B103
Package drop	10x on each of 6 axes (60 drops total) from a high of 1.2m onto a concrete surface	AEC Q100 Rev.H.
Die shear	-	MIL-STD-883 Method 2019
Humidity and temperature cycle	5 cycles (24h/cycle)	IEC 60068-2-38
Low temperature operating life	$T_A = -40^\circ\text{C}$, $V_{DD} = 3.6\text{V}$, 1000 hours	JESD22-A108
Low temperature storage	$T_A = -40^\circ\text{C}$, 1000 hours	JESD22-A119
Endurance life test	96 hours at 130dB continuous signal	AEC Q103-003
Electrostatic discharge, Human body model (HBM)	all pins, $U_{ESD} = \pm 2000\text{V}$	EIA/JESD22/A114
Electrostatic discharge, Charged device model (CDM)	all pins, $U = \pm 500\text{V}$	ESD STM 5.3.1
Electrostatic discharge, SLT - Contact discharge	3 contact discharges of $\pm 6\text{kV}$ to lid while V_{dd} and f_{CLK} are supplied according to the operational modes; V_{dd} and f_{CLK} ground is separated from earth ground	IEC-61000-4-2

(table continues...)

7 Reliability specifications
Table 9 (continued) Qualification tests according to AEC-Q103-003

Test	Stress condition	Standard
Electrostatic discharge, SLT - Air discharge	3 air discharges of $\pm 8\text{kV}$ to lid while V_{dd} and f_{CLK} are supplied according to the operational modes; V_{dd} and f_{CLK} ground is separated from earth ground	IEC-61000-4-2
Latch-up	$T_A = 105^\circ\text{C}$, $I = \pm 200\text{mA}$	AEC Q100 Rev.H.
Electromagnetic compatibility (EMC)	IC strip line radiated emissions	IEC 61967-8 / Generic IC EMC Test Specification 2.1

8 Revision history

8 Revision history

Table 10 **Revision history**

Document version	Date of release	Description of changes
1.00	18.05.2021	<ul style="list-style-type: none">• First released version

Trademarks

All referenced product or service names and trademarks are the property of their respective owners.

Edition 18-05-2021

Published by
Infineon Technologies AG
81726 Munich, Germany

© 2021 Infineon Technologies AG
All Rights Reserved.

Do you have a question about any aspect of this document?
Email: erratum@infineon.com

Document reference
IFX-rhp1599122769309

IMPORTANT NOTICE

The information given in this document shall in no event be regarded as a guarantee of conditions or characteristics ("Beschaffheitsgarantie").

With respect to any examples, hints or any typical values stated herein and/or any information regarding the application of the product, Infineon Technologies hereby disclaims any and all warranties and liabilities of any kind, including without limitation warranties of non-infringement of intellectual property rights of any third party.

In addition, any information given in this document is subject to customer's compliance with its obligations stated in this document and any applicable legal requirements, norms and standards concerning customer's products and any use of the product of Infineon Technologies in customer's applications.

The data contained in this document is exclusively intended for technically trained staff. It is the responsibility of customer's technical departments to evaluate the suitability of the product for the intended application and the completeness of the product information given in this document with respect to such application.



WARNINGS

Due to technical requirements products may contain dangerous substances. For information on the types in question please contact your nearest Infineon Technologies office.

Except as otherwise explicitly approved by Infineon Technologies in a written document signed by authorized representatives of Infineon Technologies, Infineon Technologies' products may not be used in any applications where a failure of the product or any consequences of the use thereof can reasonably be expected to result in personal injury.

Looking for pricing, stock, or lifecycle information?

Click below to explore more details on WIN SOURCE:

-  [View IM67D130AXTSA2 on WIN SOURCE](#)
-  [Infineon Technologies Information](#)

Optimize Your Supply Chain with WIN SOURCE Solutions

-  Global Sourcing Solution
-  Obsolete Management
-  Cost Control Management
-  Shortage Management
-  Alternative Solution
-  Excess Inventory Management