



**THE DATASHEET OF
ADP5092-1-EVALZ**



Evaluation Board for the **ADP5091/ADP5092** Ultralow Power Energy Harvesting PMU

GENERAL DESCRIPTION

The [ADP5091/ADP5092](#) is a 2-channel ultralow power energy harvesting PMU in a compact 4 mm × 4 mm LFCSP package. The [ADP5091-1-EVALZ](#) and [ADP5092-1-EVALZ](#) run from input voltages of 0.38 V to 3.3 V and require minimal external components to provide a high efficiency solution with integrated power switches, synchronous rectifier, battery management, and hybrid controlled and regulated output.

The [ADP5091-1-EVALZ](#) and [ADP5092-1-EVALZ](#) evaluation boards provide an easy way to evaluate the device. This user guide describes how to quickly set up the evaluation board and deliver up to 3.5 V maximum voltage to the SYS output using an external resistor divide. The internal switches turn on as long as the storage element voltage at BAT pin is above the externally programmed SETSD of 2.4 V. The PGOOD indicator toggles high when SYS ramps up to 3 V. The REG_OUT is set to 2.5 V as the default output voltage. Complete information about the [ADP5091/ADP5092](#) is available in the [ADP5091/ADP5092](#) data sheet. Consult the data sheet in conjunction with this user guide when using the evaluation boards.

ADP5091/ADP5092 EVALUATION BOARDS

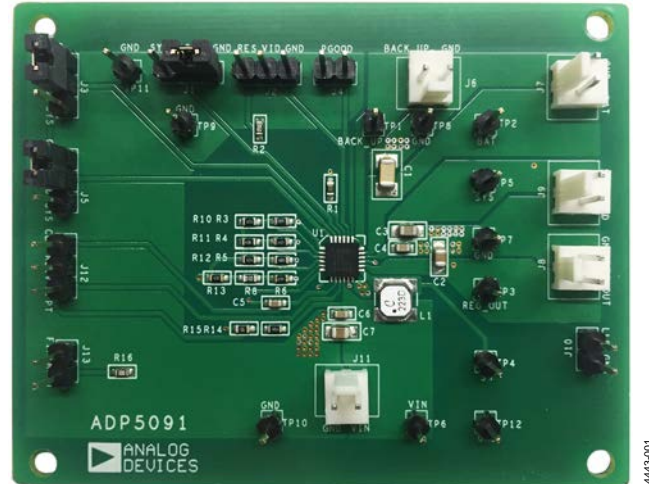

Figure 1. [ADP5091-1-EVALZ](#)

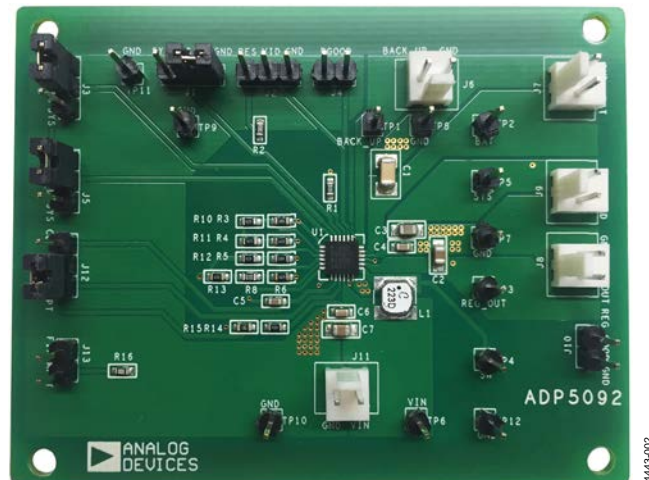

Figure 2. [ADP5092-1-EVALZ](#)

TABLE OF CONTENTS

General Description	1	Evaluation Board Schematics.....	6
ADP5091/ADP5092 Evaluation Boards	1	Evaluation Board Layout	8
Revision History	2	Ordering Information.....	10
Setting Up the Evaluation Board	3	Bill of Materials.....	10
Powering Up the Evaluation Board.....	3	Notes.....	12
Measuring Evaluation Board Performance.....	4		

REVISION HISTORY

5/2016—Revision 0: Initial Version

SETTING UP THE EVALUATION BOARD

POWERING UP THE EVALUATION BOARD

The [ADP5091-1-EVALZ](#) and [ADP5092-1-EVALZ](#) evaluation boards are fully assembled and tested. Before applying power to the evaluation board, follow the setup procedures in this section.

Jumper Settings

Table 1 describes the jumper settings.

Table 1. Jumper Settings.

Jumper	State or Connection	Function
J1 (DIS_SW)	SYS	Disables the main boost
	GND	Enables the main boost
J2 (VID)	Floating	Set REG_OUT as 2.5 V
	RES	Set output voltage by an external resistor through VID to ground
	GND	Set output voltage by external resistor divide at REG_FB pin
J3 (REG_D1)	SYS	Enable LDO mode of the REG_OUT
	GND	Disable LDO mode of the REG_OUT
J4 (PGOOD)		Pull high when the SYS voltage ramps up to preset the SETPG rising threshold
J5 (REG_D0)	SYS	Enable boost mode of the REG_OUT
	GND	Disable boost mode of the REG_OUT
J12 (RDIV)	MPPT	With MPPT sensing function
	Floating	Without MPPT dynamic sensing function, provide an external voltage at CBP pin as MPPT voltage
J13 (FIX MPPT)	Floating	Dynamic MPPT sensing mode
	Connected	MPPT fixed mode

Input Power Source Connection

Energy harvesting power sources are high impedance sources. Figure 3 shows that a source meter configured as a current source with a voltage limit set to the open circuit voltage of the harvester is the best way to simulate the harvester. For low output impedance power supply (voltage source), it is necessary to simulate the impedance of the harvester with a physical external resistor (R) between the supply and the VIN pin. If the input current source includes a voltage meter, use the meter to monitor the input voltage as follows:

1. Connect the positive terminal (+) of the power source to the VIN terminal (J11) on the evaluation board.
2. Connect the negative terminal (–) of the power source to the GND terminal (J11) on the evaluation board.

If the input power supply does not include a current meter, connect a current meter in series with the input power supply as follows:

1. Connect the external series resistor of the power source to the positive terminal (+) of the current meter.
2. Connect the negative terminal (–) of the power source to the GND terminal (J10) on the evaluation board.
3. Connect the negative terminal (–) of the current meter to the VIN terminal (J11) on the evaluation board.

SYS Load Connection

Before connecting the load to the [ADP5091-1-EVALZ](#) and [ADP5092-1-EVALZ](#) evaluation boards, ensure that the SYS voltage is higher than 2 V, or that the power-good signal is high. If the load includes a current meter, or if the current is not measured, connect the load directly to the evaluation board as follows:

1. Connect the positive load connection (+) to the SYS terminal (J9) on the evaluation board.
2. Connect the negative load connection (–) to the GND terminal (J9) on the evaluation board.

If a current meter is used, connect it in series with the load as follows:

1. Connect the positive terminal (+) of the current meter to the SYS terminal (J9) on the evaluation board.
2. Connect the negative terminal (–) of the current meter to the positive terminal (+) of the load.
3. Connect the negative terminal (–) of the load to the GND terminal (J9) on the evaluation board.

Storage Elements Connection

The [ADP5091-1-EVALZ](#) and [ADP5092-1-EVALZ](#) evaluation boards can charge some types of energy storage elements, such as: rechargeable batteries, super capacitors, and conventional capacitors. In general, the storage elements maintain constant power or peak power of the system that cannot directly come from the input source. It is necessary to consider the significant leakage current of batteries and super capacitors. For the application information, refer to the [ADP5091/ADP5092](#) data sheets.

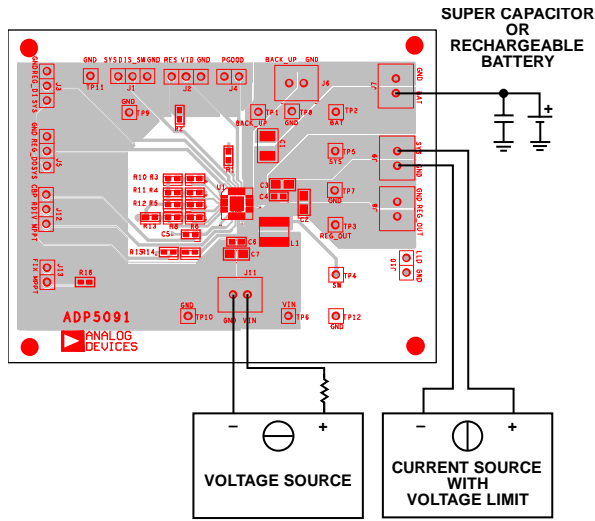

Figure 3. Setup for the ADP5091-1-EVALZ and ADP5092-1-EVALZ

Input and SYS Voltmeter Connections

Measure the input and SYS voltages with voltmeters. Ensure that the voltmeters connect to the appropriate test points on the board. If the voltmeters are not connected to the correct test points, the measured voltages may be incorrect due to the voltage drop across the leads, or due to the connections between the board, the power source, and/or the load.

1. Connect the positive terminal (+) of the input voltage measuring voltmeter to Test Point TP6 on the evaluation board.
2. Connect the negative terminal (-) of the input voltage measuring voltmeter to Test Point TP10 on the board.
3. Connect the positive terminal (+) of the output voltage measuring voltmeter to Test Point TP5 on the board.
4. Connect the negative terminal (-) of the output voltage measuring voltmeter to Test Point TP7 on the board.

REG_OUT Load Connection

REG_OUT is a regulated output that can be set via the VID pin. REG_D0 and REG_D1 control the operation mode of the REG_OUT. See the detailed configuration in Table 1. If the load includes a current meter, or if the current is not measured, connect the load directly to the evaluation board as follows:

1. Connect the positive load connection (+) to the REG_OUT terminal (J8) on the evaluation board.
2. Connect the negative load connection (-) to the GND terminal (J8) on the evaluation board.

If a current meter is used, connect it in series with the load as follows:

1. Connect the positive terminal (+) of the current meter to the REG_OUT terminal (J8) on the evaluation board.
2. Connect the negative terminal (-) of the current meter to the positive terminal (+) of the load.
3. Connect the negative terminal (-) of the load to the GND terminal (J8) on the evaluation board.

Powering On the Evaluation Board

As long as the input current source open circuit voltage is above a minimum input voltage of cold start (0.38 V), and the input power is above a minimum input power of cold start (6 μW), the ADP5091-1-EVALZ and ADP5092-1-EVALZ enter cold start, if the SYS voltage is lower than end of the cold start-up threshold (1.93 V). Otherwise, the evaluation board enables the main boost instead of the cold start.

When the MPPT sampling circuit is active, the harvester open circuit voltage is detectable because there is no input current to create a drop across the impedance. The main boost runs and draws current until the VIN voltage drops to the sampled MPPT voltage stored at CBP pin.

Optional BACK_UP Setup

An optional primary battery connected to the BACK_UP pin can accelerate the cold start or maintain the system load. When $V_{BAT} < V_{BACK_UP}$ and $V_{BAT} < V_{SET_BK}$, the ADP5091-1-EVALZ and ADP5092-1-EVALZ turn on the internal power switches between the BACK_UP pin and the SYS pin. When $V_{BAT} > V_{BACK_UP}$ and $V_{BAT} > V_{SET_BK}$, the internal power switches turn off.

MEASURING EVALUATION BOARD PERFORMANCE

Measuring the Switching Waveform

To observe the switching waveform with an oscilloscope, place the oscilloscope probe tip at Test Point TP4 with the probe ground connected to the Test Point TP12 GND. Set the oscilloscope to a dc coupling, 2 V/division, 10 μs/division time base. The switching waveform alternates between 0 V and the approximate SYS voltage.

Measuring Efficiency

Measure the efficiency (η) by comparing the input power with the output power. Figure 4 shows the test setup. Float the RDIV jumper (J12) and provide an external voltage at CBP pin as MPPT voltage so that the input voltage is regulated to this voltage. With a voltage source meter, which can sink current to connect to SYS pin, the output voltage and output current can be obtained.

$$\eta = \frac{V_{SYS} \times I_{SYS}}{V_{IN} \times I_{IN}}$$

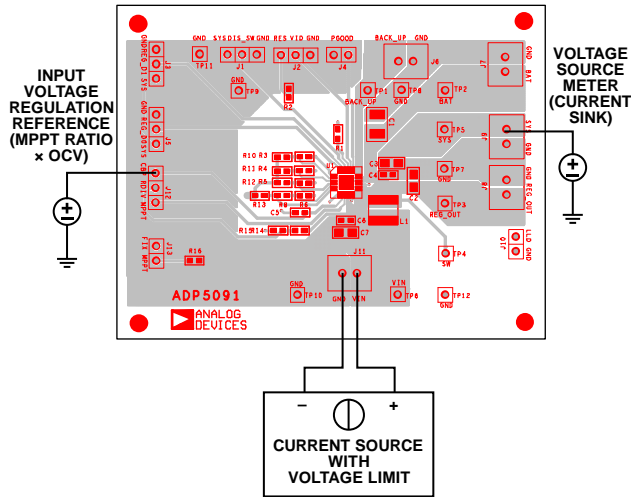

Figure 4. Setup for Measuring Efficiency

Measuring the Inductor Current

Measure the inductor current by removing one end of the inductor from the pad on the board and using a wire connected between the pad and the inductor. Then, use a current probe to measure the inductor current.

Measuring the Output Voltage Ripple

To observe the output voltage ripple, place an oscilloscope probe across output Capacitors C2 and C3 with the probe ground lead placed at the negative capacitor terminal (-) and the probe tip placed at the positive capacitor terminal (+). Set the oscilloscope to an ac coupling, 50 mV/division, 1 seconds/division time base and a 20 MHz bandwidth.

A standard oscilloscope probe has a long wire ground clip. For high frequency measurements, this ground clip picks up high frequency noise and injects it into the measured output ripple.

To eliminate the noise injection, it requires removing the oscilloscope probe sheath and wrapping a nonshielded wire around the oscilloscope probe. By keeping the ground lengths of the oscilloscope probe as short as possible, true ripple can be measured.

BAT Voltage Change

The ADP5091-1-EVALZ and ADP5092-1-EVALZ output voltages are preset to 3.5 V. However, the output voltage can be adjusted using the following equation:

$$V_{SYS} = \frac{3}{2} V_{REF} \left(1 + \frac{R5}{R12} \right)$$

To prevent deeply discharging storage elements at BAT, the voltage threshold can be programmed using the following equation:

$$V_{SETSD} = V_{REF} \left(1 + \frac{R3}{R10} \right)$$

where the typical V_{REF} value is 1.0 V.

REG_OUT Voltage Change

The regulated output voltage of the ADP5091-1-EVALZ and ADP5092-1-EVALZ can be set via VID jumper (J2). The detailed configuration is shown in Table 1. For more information on the VID resistors configuration, see the ADP5091/ADP5092 data sheets. The output voltage can also be programmable via the external feedback resistor divide using the following equation:

$$V_{REG_OUT} = V_{REF} \left(1 + \frac{R7}{R9} \right)$$

where the typical V_{REF} value is 1.0 V.

14443-004

EVALUATION BOARD SCHEMATICS

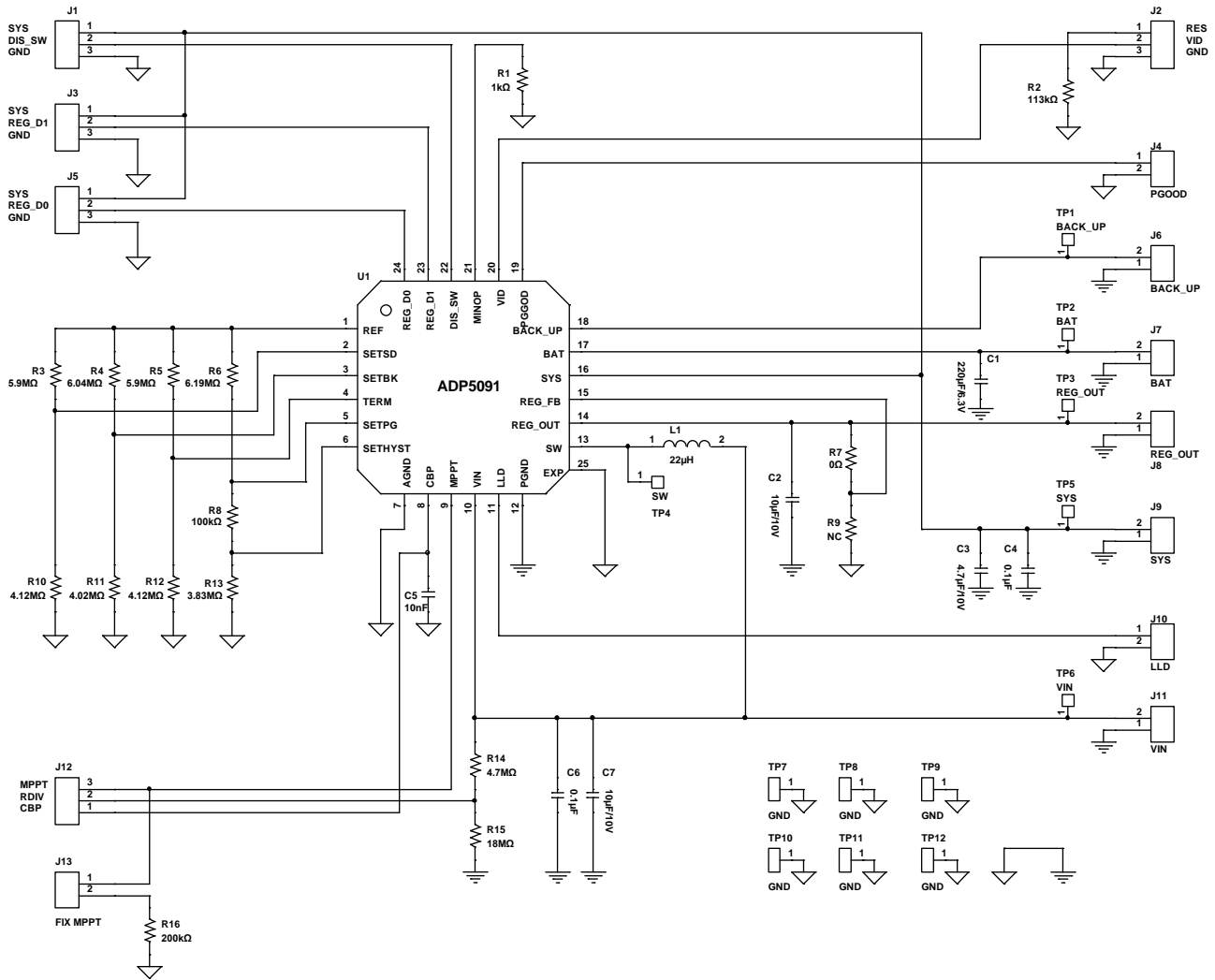

Figure 5. Schematic of the ADP5091-1-EVALZ Evaluation Board

14443-005

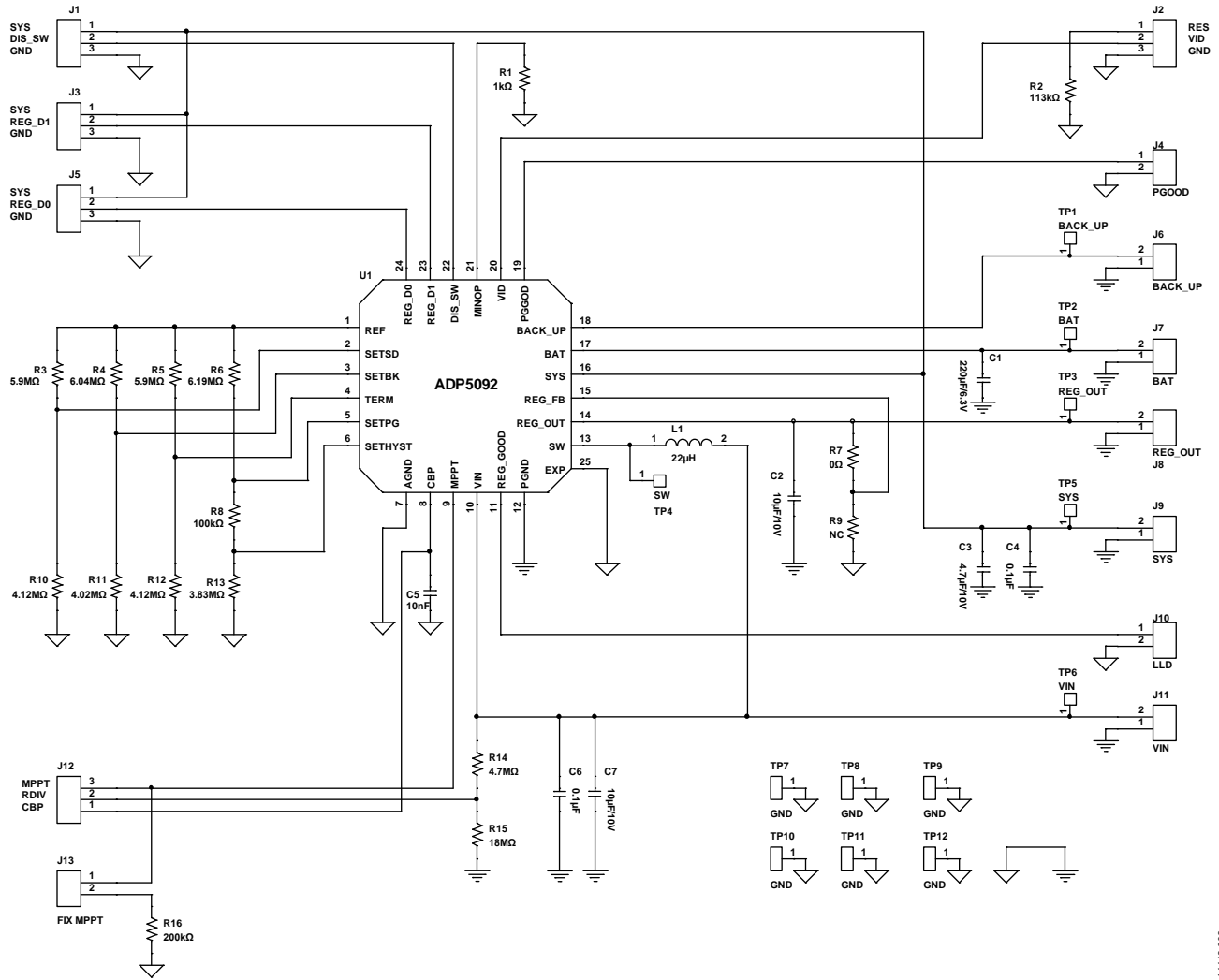

Figure 6. Schematic of the ADP5092-1-EVALZ Evaluation Board)

14443-006

EVALUATION BOARD LAYOUT

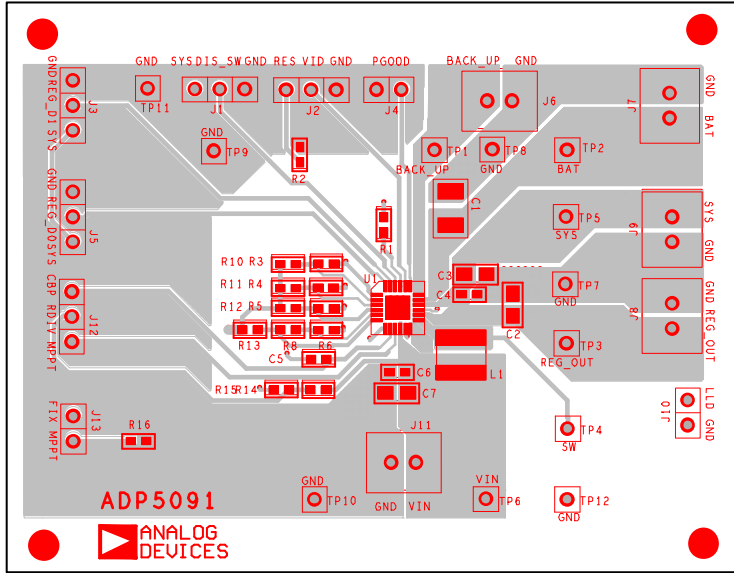

Figure 7. ADP5091-1-EVALZ Top Layer

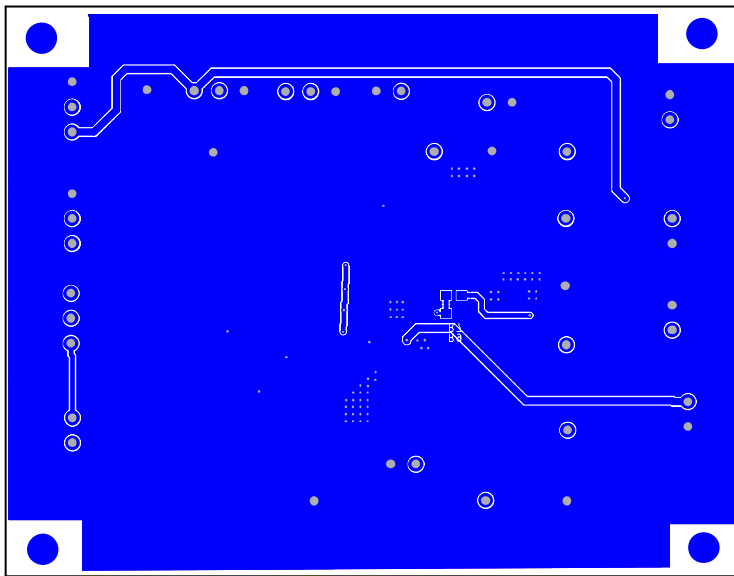

Figure 8. ADP5091-1-EVALZ Bottom Layer

ORDERING INFORMATION

BILL OF MATERIALS

Table 2. ADP5091-1-EVALZ Evaluation Board Bill of Materials

Quantity	Reference Designator	Description	Part Number	PCB Footprint	Vendor
1	C1	220 μ F/6.3 V	GRM32ER60J107ME20	C1210	Murata
2	C2, C7	10 μ F/10 V	GRM21BR71A106KE51	C0805	Murata
1	C3	4.7 μ F/10 V	GRM21BR61A475KA73	C0805	Murata
2	C4, C6	0.1 μ F	GRM188R71H104KA93	C0603	Murata
1	C5	10 nF	GRM188R71H103KA01	C0603	Murata
1	J1	DIS_SW	M20-9990246	SIP3	Harwin
1	J2	VID	M20-9990246	SIP3	Harwin
1	J3	REG_D1	M20-9990246	SIP3	Harwin
1	J4	PGOOD	M20-9990245	SIP2	Harwin
1	J5	REG_D0	M20-9990246	SIP3	Harwin
1	J6	BACK_UP	61900211121	SIP2	Würth
1	J7	BAT	61900211121?	SIP2	Harwin
1	J8	REG_OUT	61900211121?	SIP2	Harwin
1	J9	SYS	61900211121?	SIP2	Harwin
1	J10	LLD	M20-9990245	SIP2	Harwin
1	J11	VIN	61900211121?	SIP	Harwin
1	J12	RDIV	M20-9990246	SIP3	Harwin
1	J13	FIX MPPT	M20-9990245	SIP2	Harwin
1	L1	22 μ H	LPS4018-223MLB	4 mm \times 4 mm	Coilcraft
1	L1	22 μ H	74437324220	4 mm \times 4 mm	Würth
1	R1	1 k Ω	CRCW06031K00FKEA	R0603	Vishay Dale
1	R2	113 k Ω	CRCW0603113KFKEA	R0603	Vishay Dale
2	R3, R5	5.9 M Ω	CRCW06035M90FKEA	R0603	Vishay Dale
1	R4	6.04 M Ω	CRCW06036M04FKEA	R0603	Vishay Dale
1	R6	6.19 M Ω	CRCW06036M19FKEA	R0603	Vishay Dale
1	R7	0 Ω	CRCW06030000FKEA	R0603	Vishay Dale
1	R8	100 k Ω	CRCW0603100K0FKEA	R0603	Vishay Dale
1	R9	NC	N/A	R0603	Vishay Dale
2	R10, R12	4.12 M Ω	CRCW06034M12FKEA	R0603	Vishay Dale
1	R11	4.02 M Ω	CRCW06034M02FKEA	R0603	Vishay Dale
1	R13	3.83 M Ω	CRCW06033M83FKEA	R0603	Vishay Dale
1	R14	4.7 M Ω	CRCW06034M70FKEA	R0603	Vishay Dale
1	R15	18 M Ω	RK73B1JTTD186J	R0603	KOA
1	R16	200 k Ω	CRCW0603200KFKEA	R0603	Vishay Dale
1	TP1	BACK_UP	M20-9990245	SIP1	Harwin
1	TP2	BAT	M20-9990245	SIP1	Harwin
1	TP3	REG_OUT	M20-9990245	SIP1	Harwin
1	TP4	SW	M20-9990245	SIP1	Harwin
1	TP5	SYS	M20-9990245	SIP1	Harwin
1	TP6	VIN	M20-9990245	SIP1	Harwin
6	TP7, TP8, TP9, TP10, TP11, TP12	GND	M20-9990245	SIP1	Harwin
1	U1	ADP5091	ADP5091-ACZP-1-R7	24-lead LFCSP	Analog Devices, Inc.

Table 3. ADP5092-1-EVALZ Evaluation Board Bill of Materials

Quantity	Reference Designator	Description	Part Number	PCB Footprint	Vendor
1	C1	220 μ F/6.3 V	GRM32ER60J107ME20	C1210	Murata
2	C2, C7	10 μ F/10 V	GRM21BR71A106KE51	C0805	Murata
1	C3	4.7 μ F/10 V	GRM21BR61A475KA73	C0805	Murata
2	C4, C6	0.1 μ F	GRM188R71H104KA93	C0603	Murata
1	C5	10 nF	GRM188R71H103KA01	C0603	Murata
1	J1	DIS_SW	M20-9990246	SIP3	Harwin
1	J2	VID	M20-9990246	SIP3	Harwin
1	J3	REG_D1	M20-9990246	SIP3	Harwin
1	J4	PGOOD	M20-9990245	SIP2	Harwin
1	J5	REG_D0	M20-9990246	SIP3	Harwin
1	J6	BACK_UP	601900211121	SIP2	Würth
1	J7	BAT	601900211121	SIP2	Harwin
1	J8	REG_OUT	601900211121	SIP2	Harwin
1	J9	SYS	601900211121	SIP2	Harwin
1	J10	REG_OUT	M20-9990245	SIP2	Harwin
1	J11	VIN	601900211121	SIP2	Harwin
1	J12	RDIV	M20-9990246	SIP3	Harwin
1	J13	FIX MPPT	M20-9990245	SIP2	Harwin
1	L1	22 μ H	LPS4018-223MLB	4 mm \times 4 mm	Coilcraft
1	L1	22 μ H	74437324220	4 mm \times 4 mm	Würth
1	R1	1 k Ω	CRCW06031K00FKEA	R0603	Vishay Dale
1	R2	113 k Ω	CRCW0603113KFKEA	R0603	Vishay Dale
2	R3, R5	5.9 M Ω	CRCW06035M90FKEA	R0603	Vishay Dale
1	R4	6.04 M Ω	CRCW06036M04FKEA	R0603	Vishay Dale
1	R6	6.19 M Ω	CRCW06036M19FKEA	R0603	Vishay Dale
1	R7	0 Ω	CRCW06030000FKEA	R0603	Vishay Dale
1	R8	100 k Ω	CRCW0603100K0FKEA	R0603	Vishay Dale
1	R9	NC	N/A	R0603	Vishay Dale
2	R10, R12	4.12 M Ω	CRCW06034M12FKEA	R0603	Vishay Dale
1	R11	4.02 M Ω	CRCW06034M02FKEA	R0603	Vishay Dale
1	R13	3.83 M Ω	CRCW06033M83FKEA	R0603	Vishay Dale
1	R14	4.7 M Ω	CRCW06034M70FKEA	R0603	Vishay Dale
1	R15	18 M Ω	RK73B1JTTD186J	R0603	KOA
1	R16	200 k Ω	CRCW0603200KFKEA	R0603	Vishay Dale
1	TP1	BACK_UP	M20-9990245	SIP1	Harwin
1	TP2	BAT	M20-9990245	SIP1	Harwin
1	TP3	REG_OUT	M20-9990245	SIP1	Harwin
1	TP4	SW	M20-9990245	SIP1	Harwin
1	TP5	SYS	M20-9990245	SIP1	Harwin
1	TP6	VIN	M20-9990245	SIP1	Harwin
6	TP7, TP8, TP9, TP10, TP11, TP12	GND	M20-9990245	SIP1	Harwin
1	U1	ADP5092	ADP5092-ACPZ-1-R7	24-lead LFCSP	Analog Devices, Inc.

NOTES

**ESD Caution**



ESD (electrostatic discharge) sensitive device. Charged devices and circuit boards can discharge without detection. Although this product features patented or proprietary protection circuitry, damage may occur on devices subjected to high energy ESD. Therefore, proper ESD precautions should be taken to avoid performance degradation or loss of functionality.

Legal Terms and Conditions

By using the evaluation board discussed herein (together with any tools, components documentation or support materials, the "Evaluation Board"), you are agreeing to be bound by the terms and conditions set forth below ("Agreement") unless you have purchased the Evaluation Board, in which case the Analog Devices Standard Terms and Conditions of Sale shall govern. Do not use the Evaluation Board until you have read and agreed to the Agreement. Your use of the Evaluation Board shall signify your acceptance of the Agreement. This Agreement is made by and between you ("Customer") and Analog Devices, Inc. ("ADI"), with its principal place of business at One Technology Way, Norwood, MA 02062, USA. Subject to the terms and conditions of the Agreement, ADI hereby grants to Customer a free, limited, personal, temporary, non-exclusive, non-sublicensable, non-transferable license to use the Evaluation Board FOR EVALUATION PURPOSES ONLY. Customer understands and agrees that the Evaluation Board is provided for the sole and exclusive purpose referenced above, and agrees not to use the Evaluation Board for any other purpose. Furthermore, the license granted is expressly made subject to the following additional limitations: Customer shall not (i) rent, lease, display, sell, transfer, assign, sublicense, or distribute the Evaluation Board; and (ii) permit any Third Party to access the Evaluation Board. As used herein, the term "Third Party" includes any entity other than ADI, Customer, their employees, affiliates and in-house consultants. The Evaluation Board is NOT sold to Customer; all rights not expressly granted herein, including ownership of the Evaluation Board, are reserved by ADI. CONFIDENTIALITY. This Agreement and the Evaluation Board shall all be considered the confidential and proprietary information of ADI. Customer may not disclose or transfer any portion of the Evaluation Board to any other party for any reason. Upon discontinuation of use of the Evaluation Board or termination of this Agreement, Customer agrees to promptly return the Evaluation Board to ADI. ADDITIONAL RESTRICTIONS. Customer may not disassemble, decompile or reverse engineer chips on the Evaluation Board. Customer shall inform ADI of any occurred damages or any modifications or alterations it makes to the Evaluation Board, including but not limited to soldering or any other activity that affects the material content of the Evaluation Board. Modifications to the Evaluation Board must comply with applicable law, including but not limited to the RoHS Directive. TERMINATION. ADI may terminate this Agreement at any time upon giving written notice to Customer. Customer agrees to return to ADI the Evaluation Board at that time. LIMITATION OF LIABILITY. THE EVALUATION BOARD PROVIDED HEREUNDER IS PROVIDED "AS IS" AND ADI MAKES NO WARRANTIES OR REPRESENTATIONS OF ANY KIND WITH RESPECT TO IT. ADI SPECIFICALLY DISCLAIMS ANY REPRESENTATIONS, ENDORSEMENTS, GUARANTEES, OR WARRANTIES, EXPRESS OR IMPLIED, RELATED TO THE EVALUATION BOARD INCLUDING, BUT NOT LIMITED TO, THE IMPLIED WARRANTY OF MERCHANTABILITY, TITLE, FITNESS FOR A PARTICULAR PURPOSE OR NONINFRINGEMENT OF INTELLECTUAL PROPERTY RIGHTS. IN NO EVENT WILL ADI AND ITS LICENSORS BE LIABLE FOR ANY INCIDENTAL, SPECIAL, INDIRECT, OR CONSEQUENTIAL DAMAGES RESULTING FROM CUSTOMER'S POSSESSION OR USE OF THE EVALUATION BOARD, INCLUDING BUT NOT LIMITED TO LOST PROFITS, DELAY COSTS, LABOR COSTS OR LOSS OF GOODWILL. ADI'S TOTAL LIABILITY FROM ANY AND ALL CAUSES SHALL BE LIMITED TO THE AMOUNT OF ONE HUNDRED US DOLLARS (\$100.00). EXPORT. Customer agrees that it will not directly or indirectly export the Evaluation Board to another country, and that it will comply with all applicable United States federal laws and regulations relating to exports. GOVERNING LAW. This Agreement shall be governed by and construed in accordance with the substantive laws of the Commonwealth of Massachusetts (excluding conflict of law rules). Any legal action regarding this Agreement will be heard in the state or federal courts having jurisdiction in Suffolk County, Massachusetts, and Customer hereby submits to the personal jurisdiction and venue of such courts. The United Nations Convention on Contracts for the International Sale of Goods shall not apply to this Agreement and is expressly disclaimed.

Looking for pricing, stock, or lifecycle information?

Click below to explore more details on WIN SOURCE:

-  [View ADP5092-1-EVALZ on WIN SOURCE](#)
-  [Analog Devices Inc. Information](#)

Optimize Your Supply Chain with WIN SOURCE Solutions

-  Global Sourcing Solution
-  Obsolete Management
-  Cost Control Management
-  Shortage Management
-  Alternative Solution
-  Excess Inventory Management