



THE DATASHEET OF LT685CH



FEATURES

- Ultrafast (5.5ns typ)
- Complementary ECL Output
- 50Ω Line Driving Capability
- Low Offset Voltage
- Output Latch Capability
- External Hysteresis Control
- Pin Compatible with Am685

APPLICATIONS

- High Speed A-to-D Converters
- High Speed Sampling Circuits
- Oscillators

DESCRIPTION

The LT[®]685 is an ultrafast comparator with differential inputs and complementary outputs fully compatible with ECL logic levels. The output current capability is adequate for driving transmission lines terminated in 50Ω. The low input offset and high resolution make this comparator ideally suited for analog-to-digital signal processing applications.

A latch function is provided to allow the comparator to be used in a sample-hold mode. When the latch enable input is ECL high, the comparator functions normally. When the latch enable is driven low, the comparator outputs are locked in their existing logical states. If the latch function is not used, the latch enable must be connected to ground or ECL high.

The device is pin-compatible with the Am685. Hysteresis has been added to improve switching time with slow input signals as well as to minimize oscillation. A single resistor between the hysteresis pin and V^- adds input hysteresis voltage as more current is drawn. If hysteresis is not required, the pin can be left unconnected.

 LTC and LT are registered trademarks of Linear Technology Corporation.

TYPICAL APPLICATION

Comparator with Hysteresis

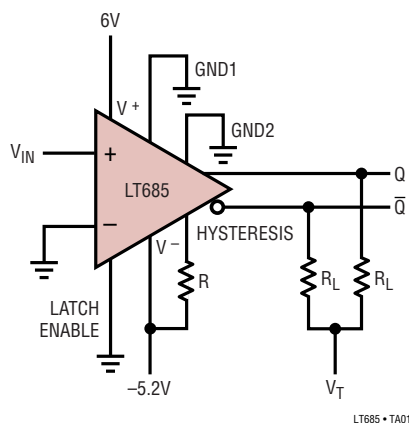

Hysteresis

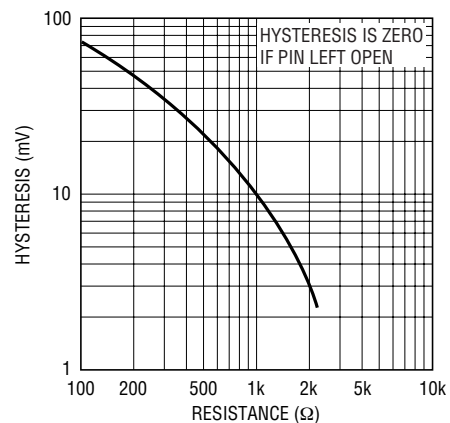

ABSOLUTE MAXIMUM RATINGS

(Note 1)

Positive Supply Voltage	7V
Negative Supply Voltage	-7V
Input Voltage	±4V
Differential Input Voltage	±6V
Latch Pin Voltage	2V to V ⁻
Hysteresis Pin Voltage	0V to V ⁻

Output Current	30mA
Power Dissipation (Note 2)	500mW
Operating Temperature	
LT685C	-30°C ≤ T _A ≤ 85°C
LT685M (OBSELETE)	-55°C ≤ T _A ≤ 125°C

PACKAGE/ORDER INFORMATION

<p>TOP VIEW GND #1 GND #2 V⁺ V⁻ NONINVERTING INPUT INVERTING INPUT LATCH ENABLE HYSTERESIS Q̄ OUTPUT Q OUTPUT H PACKAGE TO-5 METAL CAN</p> <p>OBSELETE PACKAGE Consider the N16 Package as an Alternate Source</p>	<p>ORDER PART NUMBER</p> <p>LT685CH LT685MH</p>	<p>TOP VIEW GND #1 GND #2 V⁺ V⁻ NON-INVERTING INPUT INVERTING INPUT NC LATCH ENABLE NC V⁻ Q̄ OUTPUT Q OUTPUT NC NC NC HYSTERESIS N16 PACKAGE 16-LEAD CERDIP</p>	<p>ORDER PART NUMBER</p> <p>LT685CN</p>
	<p>OBSELETE PACKAGE Consider the N16 Package as an Alternate Source</p>		<p>ORDER PART NUMBER</p> <p>LT685CJ LT685MJ</p> <p><small>LT685 • P0101</small></p>

Consult LTC Marketing for parts specified with wider operating temperature ranges.

ELECTRICAL CHARACTERISTICS $V^+ = 6.0V$, $V^- = -5.2V$, $V_T = -2V$, $R_L = 50\Omega$, $R = \infty$ over the operating temperature ranges, unless otherwise noted.

SYMBOL	PARAMETER	CONDITIONS	LT685C			LT685M			UNITS
			MIN	TYP	MAX	MIN	TYP	MAX	
V _{OS}	Input Offset Voltage	T _A = 25°C		1.0	±2.0		1.0	±2.0	mV
					±2.5			±3.0	mV
dV _{OS} /dT	Input Offset Voltage Drift	(Note 3)			±10			±10	µV/°C
I _{OS}	Input Offset Current	T _A = 25°C		0.3	±1.0		0.3	±1.0	µA
					±1.3			±1.6	µA
I _B	Input Bias Current	T _A = 25°C		5	10		5	10	µA
					13			16	µA
R _{IN}	Input Resistance	T _A = 25°C (Note 3)	6.0			6.0			kΩ
C _{IN}	Input Capacitance	T _A = 25°C (Note 3)			3.0			3.0	pF
V _{CM}	Input Voltage Range				±3.3			±3.3	V
CMRR	Common Mode Rejection		80			80			dB
SVRR	Supply Voltage Rejection		70			70			dB
V _{OH}	Output High Voltage	T _A = 25°C	-0.960	-0.810		-0.960	-0.810		V
		T _A = T _{MIN}	-1.060	-0.890		-1.100	-0.920		V
		T _A = T _{MAX}	-0.890	-0.700		-0.850	-0.620		V
V _{OL}	Output Low Voltage	T _A = 25°C	-1.850	-1.650		-1.850	-1.650		V
		T _A = T _{MIN}	-1.890	-1.675		-1.910	-1.690		V
		T _A = T _{MAX}	-1.825	-1.625		-1.810	-1.575		V
I ⁺	Positive Supply Current			22			22		mA
I ⁻	Negative Supply Current			26			26		mA
P _{DISS}	Power Dissipation			300			300		mW

SWITCHING CHARACTERISTICS ($V_{IN} = 100\text{mV}$ step, 5mV overdrive)

SYMBOL	PARAMETER	CONDITIONS	LT685C			LT685M			UNITS
			MIN	TYP	MAX	MIN	TYP	MAX	
t_{PD}	Propagation Delay (Note 4)	$T_A = 25^\circ\text{C}$	4.5	5.5	6.5	4.5	5.5	6.5	ns
		$T_A = T_{MAX}$	5.0		9.5	5.5		12	ns
		$T_A = T_{MIN}$	4.0		6.5	3.5		6.5	ns
$t_{PD(E)}$	Latch Enable to Output Delay (Note 3)	$T_A = 25^\circ\text{C}$	4.5	5.5	6.5	4.5	5.5	6.5	ns
		$T_A = T_{MAX}$	5.0		9.5	5.5		12	ns
		$T_A = T_{MIN}$	4.0		6.5	3.5		6.5	ns
t_S	Minimum Set-Up Time (Note 3)	$T_{MIN} \leq T_A \leq 25^\circ\text{C}$			3.0			3.0	ns
		$T_A = T_{MAX}$			4.0			6.0	ns
t_H	Minimum Hold Time (Note 3)	$T_{MIN} \leq T_A \leq T_{MAX}$			1.0			1.0	ns
$t_{PW(E)}$	Minimum Latch Enable Pulse Width (Note 3)	$T_{MIN} \leq T_A \leq 25^\circ\text{C}$			3.0			3.0	ns
		$T_A = T_{MAX}$			4.0			5.0	ns

Note 1: Absolute Maximum Ratings are those values beyond which the life of a device may be impaired.

Note 2: For the metal can package, derate at 6.8mW/°C for operation at ambient temperatures above 100°C; for the hermetic dual-in-line package, derate at 9mW/°C for operation at ambient temperatures above 105°C.

Note 3: Guaranteed by design, but not tested.

Note 4: Sample tested at 25°C only.

Definitions:

t_{PD} : The propagation delay measured from the time the input signal crosses the input offset voltage to the 50% point of the output transition.

$t_{PD(E)}$: The propagation delay measured from the 50% point of the latch enable signal positive transition to the 50% point of the output transition.

t_S : The minimum time before the negative transition of the latch enable signal that an input signal change must be present in order to be acquired and held at the outputs.

t_H : The minimum time after the negative transition of the latch enable signal that the input signal must remain unchanged in order to be acquired and held at the outputs.

$t_{PW(E)}$: The minimum time that the latch enable signal must be HIGH in order to acquire and hold an input signal change.

SCHEMATIC DIAGRAM

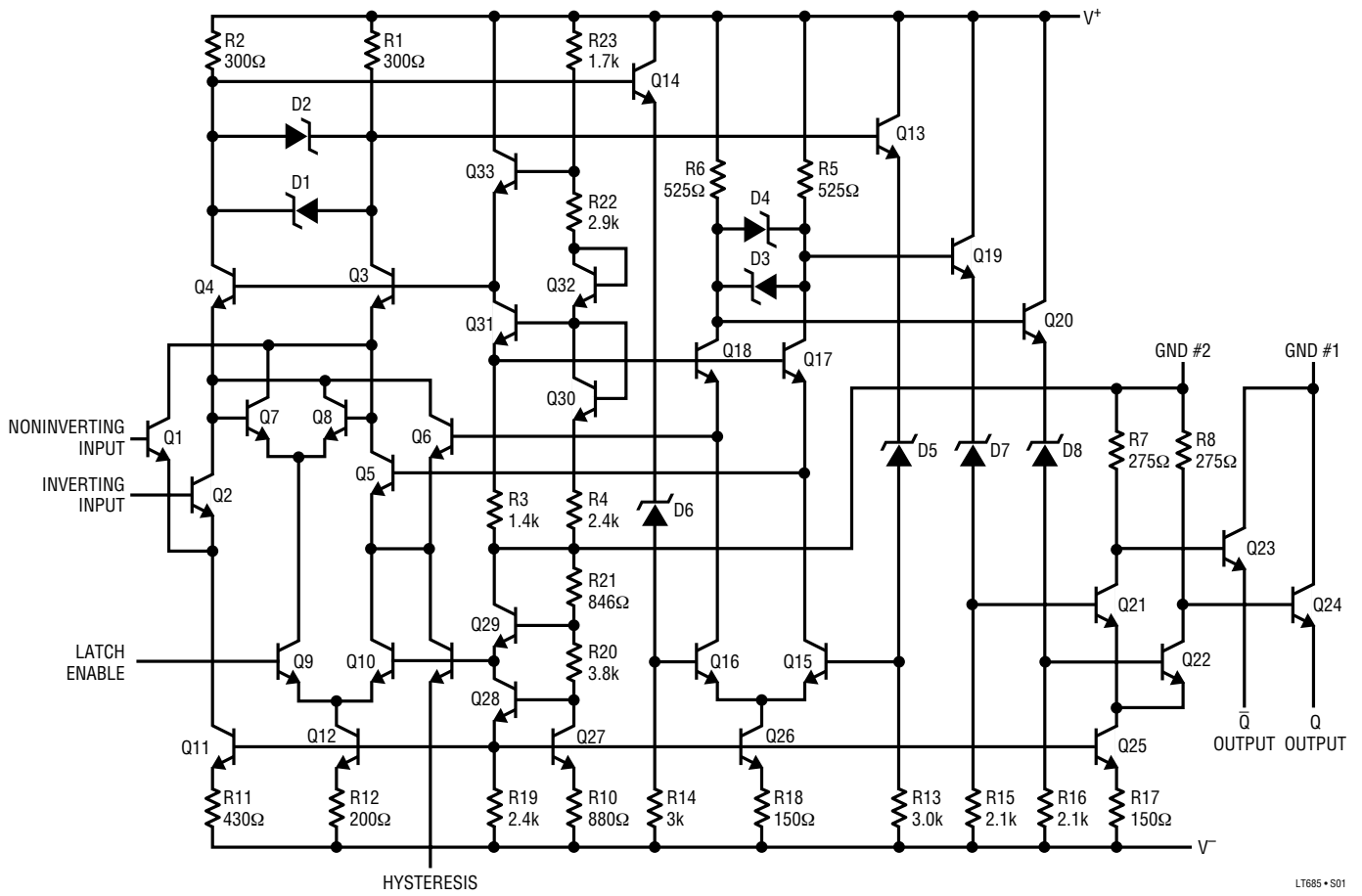

LT685 • S01

TYPICAL PERFORMANCE CHARACTERISTICS

Propagation Delays as a Function of Temperature

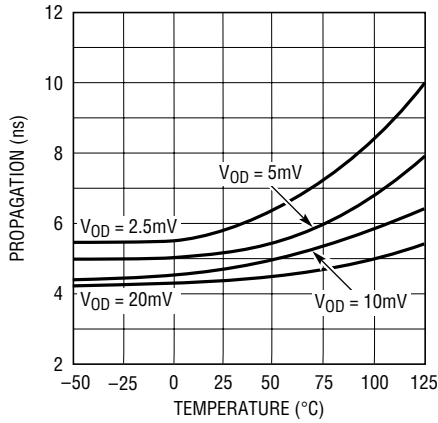

LTC685 • TPC01

Hysteresis as a Function of Temperature

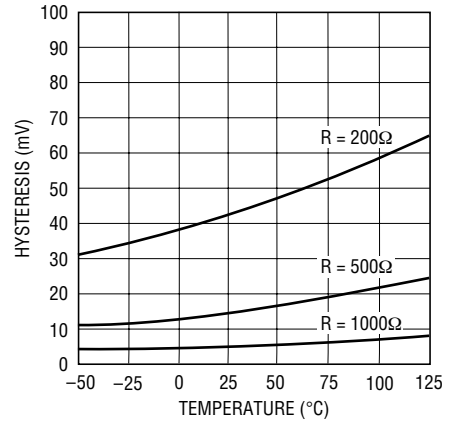

LTC685 • TPC02

PACKAGE DESCRIPTION

H Package
10-Lead TO-5 Metal Can
(Reference LTC DWG # 05-08-1322)

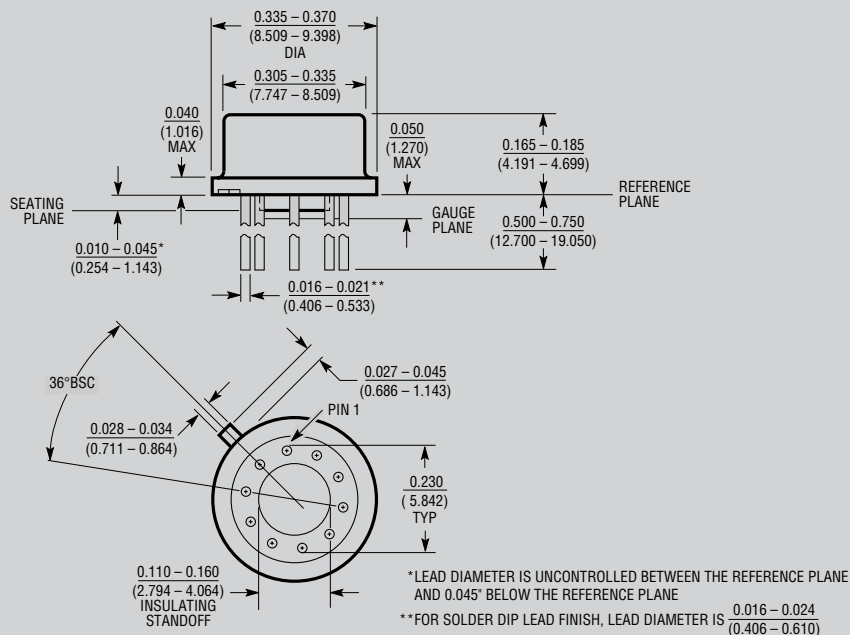

H10(TO-5) 1197

OBsolete PACKAGE

PACKAGE DESCRIPTION

J Package 16-Lead CERDIP (Narrow .300 Inch, Hermetic) (Reference LTC DWG # 05-08-1110)

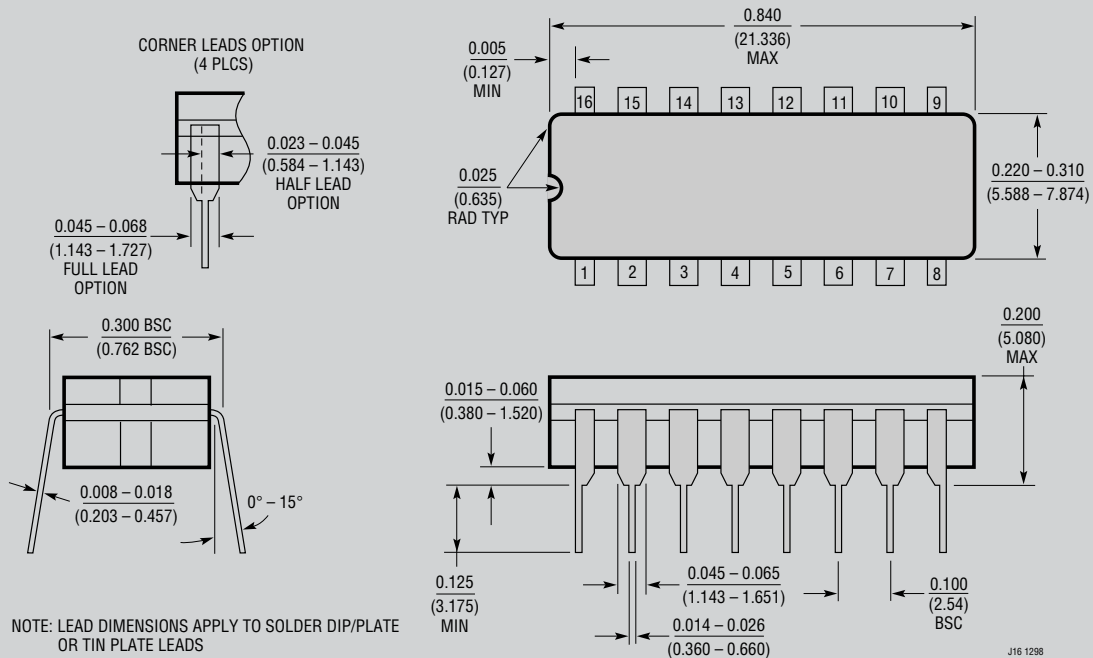

OBSOLETE PACKAGE

PACKAGE DESCRIPTION

N Package
16-Lead PDIP (Narrow .300 Inch)
 (Reference LTC DWG # 05-08-1510)

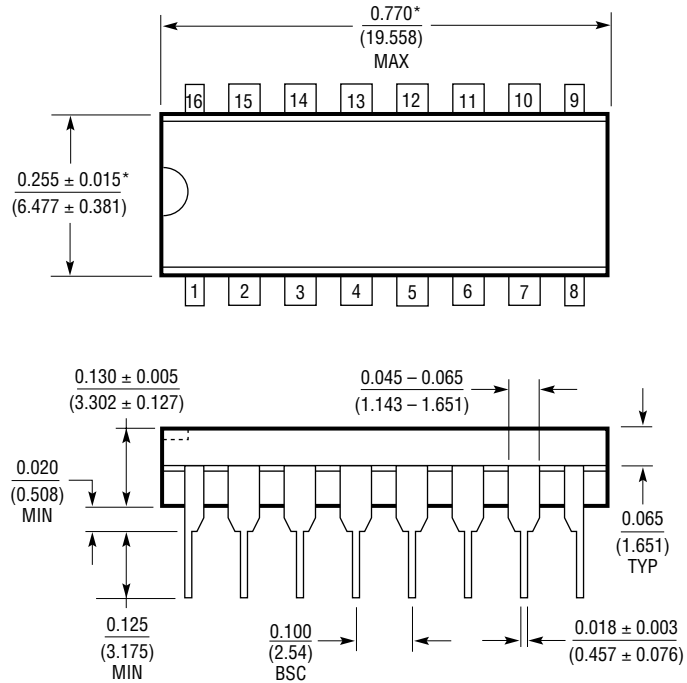



*THESE DIMENSIONS DO NOT INCLUDE MOLD FLASH OR PROTRUSIONS.
 MOLD FLASH OR PROTRUSIONS SHALL NOT EXCEED 0.010 INCH (0.254mm)

N16 1098

Looking for pricing, stock, or lifecycle information?

Click below to explore more details on WIN SOURCE:

-  [View LT685CH on WIN SOURCE](#)
-  [Analog Devices Inc. Information](#)

Optimize Your Supply Chain with WIN SOURCE Solutions

-  Global Sourcing Solution
-  Obsolete Management
-  Cost Control Management
-  Shortage Management
-  Alternative Solution
-  Excess Inventory Management