



# THE DATASHEET OF HMC1105





## GaAs MMIC x2 PASSIVE FREQUENCY MULTIPLIER, 20 - 40 GHz INPUT

### Typical Applications

The HMC1105 is ideal for:

- Microwave Test Equipment
- Microwave/mmWave Radios
- E-Band Radios
- Military and Space

### Features

- Passive: No DC Bias Required
- Conversion Loss: 12 dBm
- Fo Isolation: 41 dB
- 3Fo Isolation: 46 dB
- Die Size: 1.79 x 1.19 x 0.1 mm

### Functional Diagram

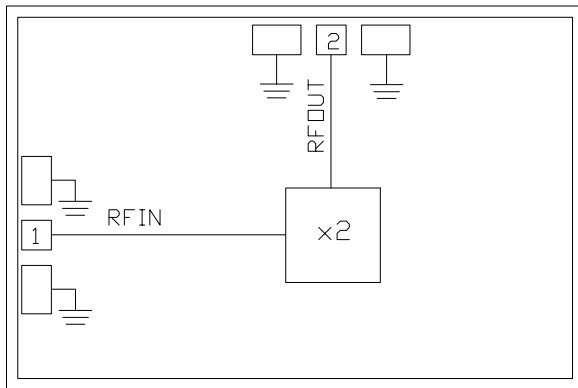

### General Description

The HMC1105 is a passive miniature frequency doubler in a MMIC die. Suppression of undesired fundamental and higher order harmonics is up to 41 dB typical with respect to input signal level. The doubler utilizes the same GaAs Schottky diode/balun technology found in Hittite MMIC mixers. The HMC1105 features small size, requires no DC bias, and adds no measurable additive phase noise onto the multiplied signal. The HMC1105 is compatible with conventional die attach methods which make it ideal for MCM and hybrid microcircuit applications. All data shown herein is measured with the chip in a 50 ohm environment and contacted with RF probes.

### Electrical Specifications, $T_A = +25^\circ\text{C}$ , Input Drive Level = +15 dBm

Parameter	Min.	Typ.	Max	Min.	Typ.	Max.	Units
Frequency Range Input		20 - 30			30 - 40		GHz
Frequency Range Output		40 - 60			60 - 80		GHz
Conversion Loss		11	15		12	16	dB
Input Return Loss		7			6		dB
Output Return Loss		13			7		dB
FO Isolation		41			41		dB
3Fo Isolation		42			46		dB



**GaAs MMIC x2 PASSIVE FREQUENCY MULTIPLIER, 20 - 40 GHz INPUT**

**Conversion Loss vs. Temperature @ +13 dBm Drive Level**

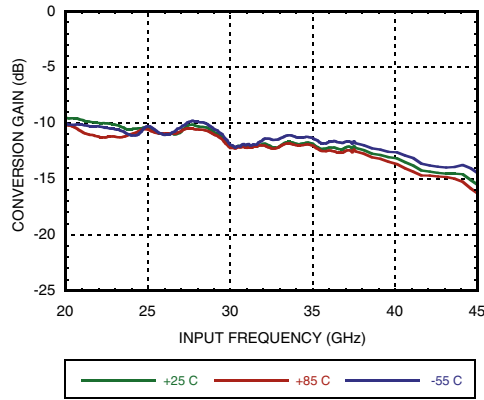

**Conversion Loss vs. Drive Level**

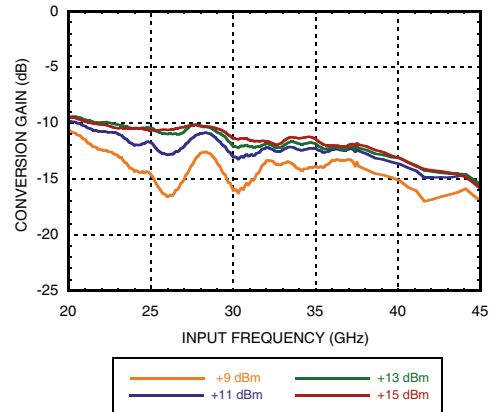

**Isolation @ vs. Drive Level [1]**

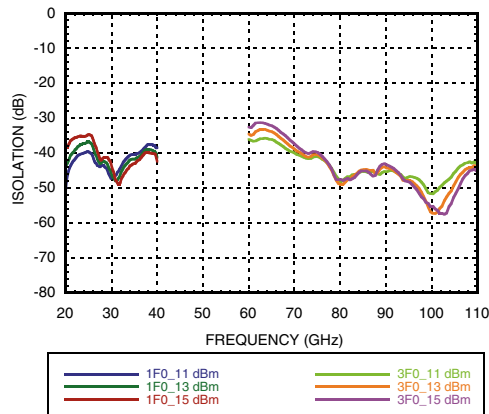

**Input Return Loss**

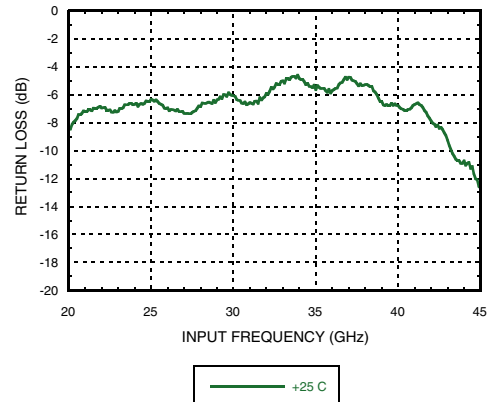

**Output Return Loss**

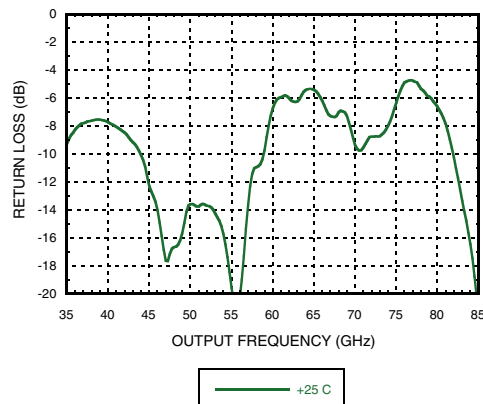

[1] Isolation measurement taken with respect to input level



## GaAs MMIC x2 PASSIVE FREQUENCY MULTIPLIER, 20 - 40 GHz INPUT

### Absolute Maximum Ratings

RF Power Input	+17 dBm
Channel Temperature	175 °C
Thermal Resistance (R <sub>TH</sub> ) (junction to die bottom)	555.6 °C/W
Operating Temperature	-55 to +85 °C
Storage Temperature	-65 to 150 °C
ESD Sensitivity (HBM)	Class 1A, passed 250 V



ELECTROSTATIC SENSITIVE DEVICE  
OBSERVE HANDLING PRECAUTIONS

### Outline Drawing

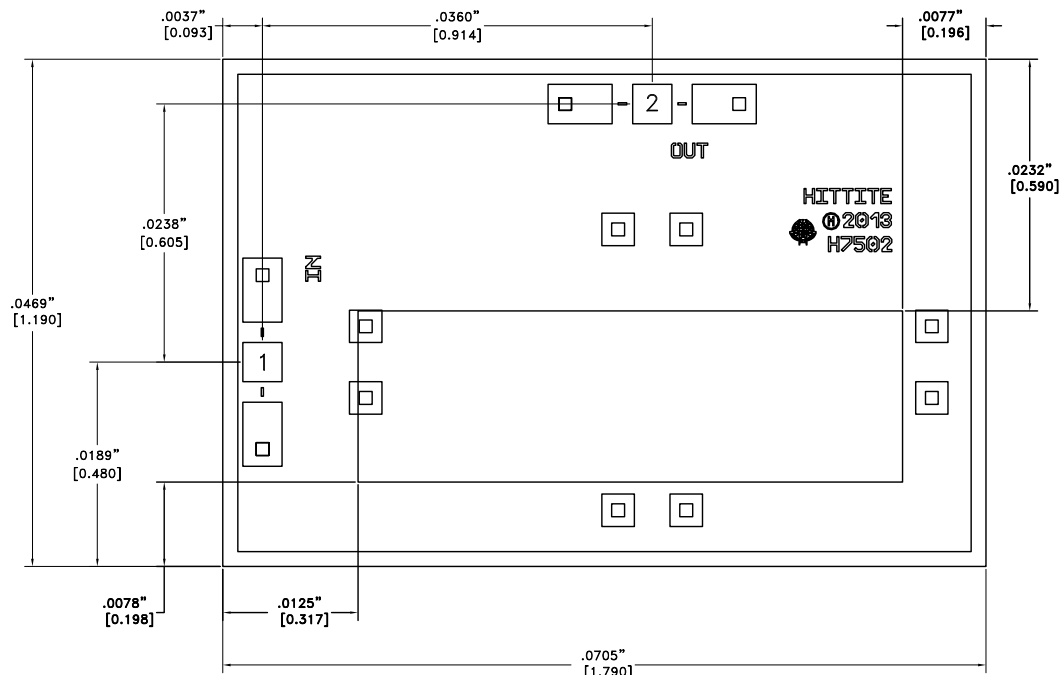

### Die Packaging Information [1]

Standard	Alternate
GP-2 (Gel Pack)	[2]

[1] For more information refer to the "Packaging information" Document in the Product Support Section of our website.

[2] For alternate packaging information contact Hittite Microwave Corporation.

#### NOTES:

1. ALL DIMENSIONS ARE IN INCHES [MM].
2. DIE THICKNESS IS 0.004"
3. BOND PADS 1, 2 & 3 are 0.0059" [0.150] X 0.0039" [0.099].
4. BACKSIDE METALLIZATION: GOLD.
5. BOND PAD METALLIZATION: GOLD.
6. BACKSIDE METAL IS GROUND.
7. CONNECTION NOT REQUIRED FOR UNLABELED BOND PADS.
8. OVERALL DIE SIZE ± 0.002



**GaAs MMIC x2 PASSIVE FREQUENCY  
MULTIPLIER, 20 - 40 GHz INPUT**

**Pad Descriptions**

Pad Number	Function	Description	Pad Schematic
1	RFIN	This pad is AC coupled and matched to 50 Ohms.	RFIN ○ —  —
2	RFOUT	This pad is AC coupled and matched to 50 Ohms.	—  — ○ RFOUT
Die Bottom	GND	Die bottom must be connected to RF/DC ground	○ GND ⏏

**Assembly Diagram**

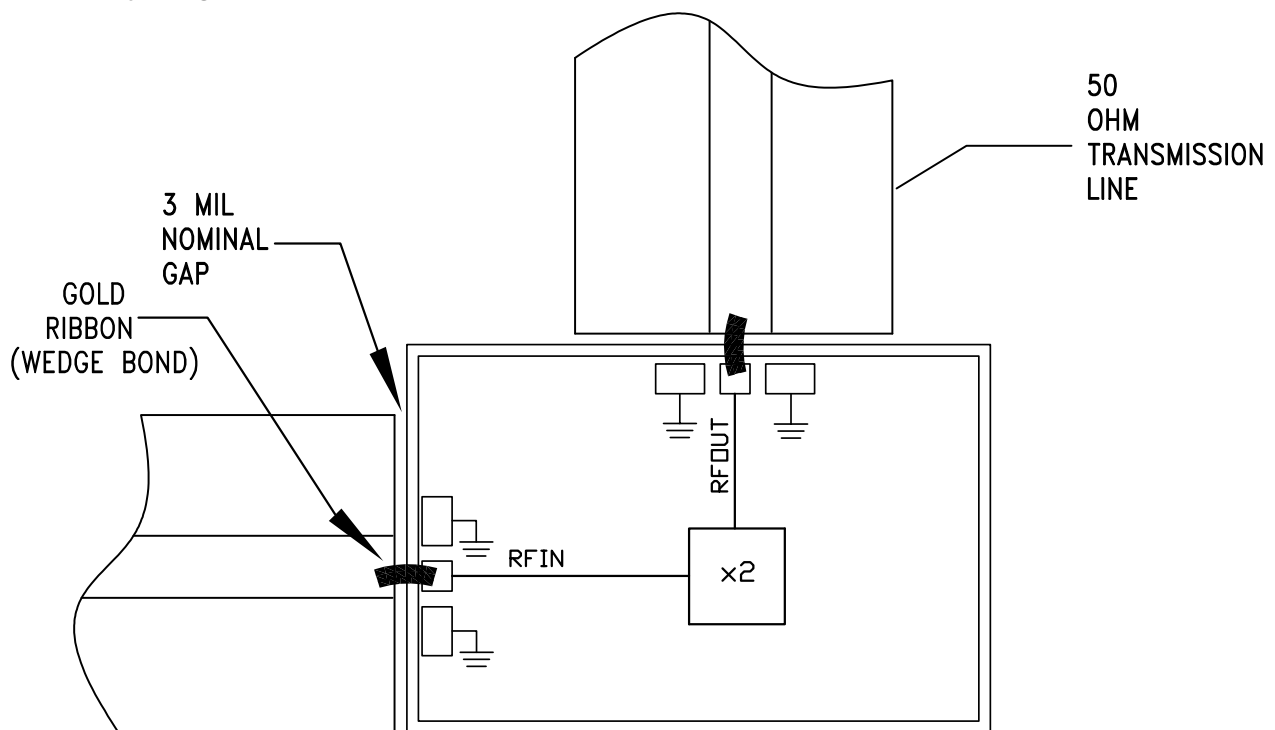

Information furnished by Analog Devices is believed to be accurate and reliable. However, no responsibility is assumed by Analog Devices for its use, nor for any infringements of patents or other rights of third parties that may result from its use. Specifications subject to change without notice. No license is granted by implication or otherwise under any patent or patent rights of Analog Devices. Trademarks and registered trademarks are the property of their respective owners.

For price, delivery, and to place orders: Analog Devices, Inc., One Technology Way, P.O. Box 9106, Norwood, MA 02062-9106 Phone: 781-329-4700 • Order online at [www.analog.com](http://www.analog.com) Application Support: Phone: 1-800-ANALOG-D



## GaAs MMIC x2 PASSIVE FREQUENCY MULTIPLIER, 20 - 40 GHz INPUT

### Mounting & Bonding Techniques for Millimeterwave GaAs MMICs

The die should be attached directly to the ground plane eutectically or with conductive epoxy (see HMC general Handling, Mounting, Bonding Note).

50 Ohm Microstrip transmission lines on 0.127mm (5 mil) thick alumina thin film substrates are recommended for bringing RF to and from the chip (Figure 1). One way to accomplish this is to attach the 0.102mm (4 mil) thick die to a 0.150mm (6 mil) thick molybdenum heat spreader (moly-tab) which is then attached to the ground plane (Figure 2). Microstrip substrates should be located as close to the die as possible in order to minimize bond wire length. Typical die-to-substrate spacing is 0.076mm to 0.152 mm (3 to 6 mils).

#### Handling Precautions

Follow these precautions to avoid permanent damage.

**Storage:** All bare die are placed in either Waffle or Gel based ESD protective containers, and then sealed in an ESD protective bag for shipment. Once the sealed ESD protective bag has been opened, all die should be stored in a dry nitrogen environment.

**Cleanliness:** Handle the chips in a clean environment. DO NOT attempt to clean the chip using liquid cleaning systems.

**Static Sensitivity:** Follow ESD precautions to protect against > ± 250V ESD strikes.

**Transients:** Suppress instrument and bias supply transients while bias is applied. Use shielded signal and bias cables to minimize inductive pick-up.

**General Handling:** Handle the chip along the edges with a vacuum collet or with a sharp pair of bent tweezers. The surface of the chip may have fragile air bridges and should not be touched with vacuum collet, tweezers, or fingers.

#### Mounting

The chip is back-metallized and can be die mounted with AuSn eutectic preforms or with electrically conductive epoxy. The mounting surface should be clean and flat.

**Eutectic Die Attach:** A 80/20 gold tin preform is recommended with a work surface temperature of 255 °C and a tool temperature of 265 °C. When hot 90/10 nitrogen/hydrogen gas is applied, tool tip temperature should be 290 °C. DO NOT expose the chip to a temperature greater than 320 °C for more than 20 seconds. No more than 3 seconds of scrubbing should be required for attachment.

**Epoxy Die Attach:** Apply a minimum amount of epoxy to the mounting surface so that a thin epoxy fillet is observed around the perimeter of the chip once it is placed into position. Cure epoxy per the manufacturer's schedule.

#### Wire Bonding

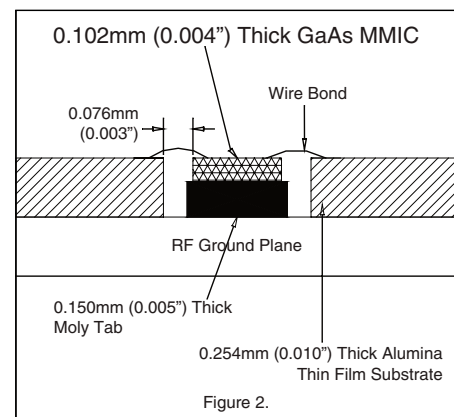
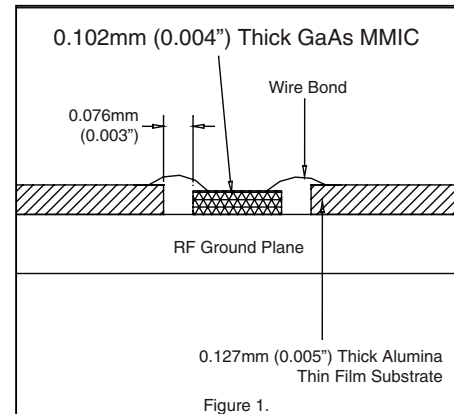

Ball or wedge bond with 0.025mm (1 mil) diameter pure gold wire. Thermosonic wirebonding with a nominal stage temperature of 150 °C and a ball bonding force of 40 to 50 grams or wedge bonding force of 18 to 22 grams is recommended. Use the minimum level of ultrasonic energy to achieve reliable wirebonds. Wirebonds should be started on the chip and terminated on the package or substrate. All bonds should be as short as possible <0.31mm (12 mils).



**GaAs MMIC x2 PASSIVE FREQUENCY  
MULTIPLIER, 20 - 40 GHz INPUT****Notes:**

## Looking for pricing, stock, or lifecycle information?

Click below to explore more details on WIN SOURCE:

-  [View HMC1105 on WIN SOURCE](#)
-  [Analog Devices Inc. Information](#)

## Optimize Your Supply Chain with WIN SOURCE Solutions

-  Global Sourcing Solution
-  Obsolete Management
-  Cost Control Management
-  Shortage Management
-  Alternative Solution
-  Excess Inventory Management