



**THE DATASHEET OF
TLE493DA2B6HTSA1**



TLE493D-A2B6 MS2GO

3D Magnetic Sensor 2 Go evaluation kit

User Manual

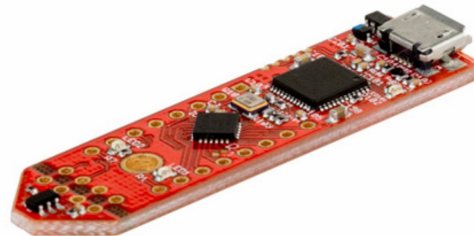
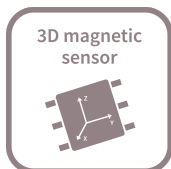

About this document

Scope and purpose

This document provides an introduction to the 3D Magnetic Sensor 2 Go kit and should enable the reader to efficiently carry out own evaluations with the 3D magnetic sensor TLE493D-A2B6.

Intended audience

This document is aimed at everyone who wants to work with the 3D Magnetic Sensor 2 Go evaluation kit.

Table of contents

	User Manual	1
	About this document	1
	Table of contents	2
1	Introduction	3
1.1	Hardware overview	3
1.2	Software	3
1.3	Hardware extensions	4
2	EvalBoard description	7
2.1	Optional external power supply	7
2.2	Pin header connector	8
2.3	EvalBoard schematics	9
3	Software installation	13
3.1	Driver installation	16
4	3D magnetic sensor evaluation	20
4.1	Getting started	20
4.2	Graph View	21
4.3	Joystick view	22
4.4	Rotation view	22
4.5	Linear movement	23
4.6	Out of shaft	24
5	Example code for developers	26
6	XMC for Arduino	27
	Revision history	28
	Disclaimer	29

Introduction

1 Introduction

Infineon's **3D Magnetic Sensor 2 Go** is a compact evaluation kit to familiarize the user with the 3D Hall sensor TLE493D-A2B6. In a short time the board is set up and own 3D magnetic measurements can be executed. All required hardware is included and the software can be downloaded for free from the Infineon web page. This user manual describes the different parts of the board, the software installation process and clarifies how the Graphical User Interface (GUI) can be used to do first evaluations. Further it is shown where to find example code and an Arduino library as a easy starting point for own developments.

1.1 Hardware overview

The 3D Magnetic Sensor 2 Go kit contains:

- The 3D evaluation board (EvalBoard) as shown in **Figure 1**, a ready-to-use printed circuit board (PCB) with the 3D Hall sensor. The EvalBoard is based on the XMC2Go-Kit. More technical documents and detailed description can be found at <http://www.infineon.com/xmc2go>
- A standalone 7x7x5 mm ferrite block magnet

To use the 3D Magnetic Sensor 2 Go kit the user has to acquire a USB cable with a micro USB connection-end for the EvalBoard side and a conventional USB connection for the PC side.

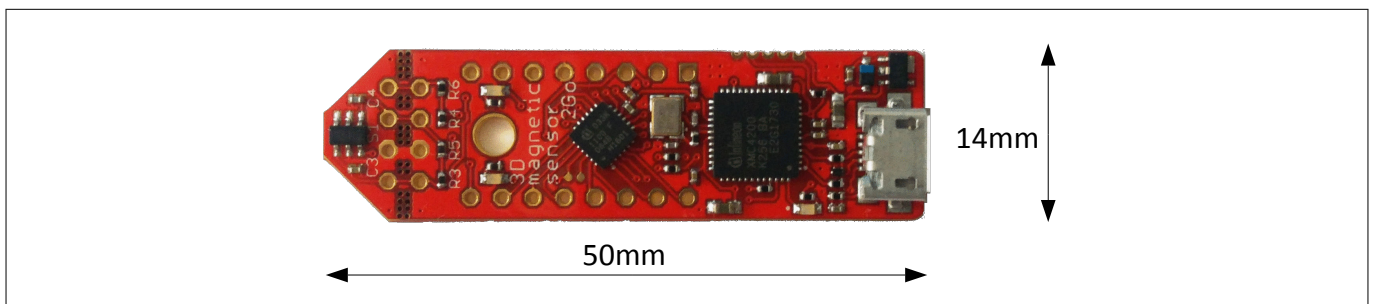

Figure 1 **3D Magnetic Sensor 2 Go EvalBoard**

1.2 Software

The required software to run the kit can be found at the Infineon web site. For further information refer to the chapter **Software installation**.

The software package contains:

- A Graphical User Interface (GUI) for sensor evaluation.
- Firmware to be flashed into the XMC microcontroller for the low level communication with the sensor.
- USB driver J-Link from Segger which is necessary to establish the USB connection.

This software was designed to be used with Windows 7 and Windows 10. It is compatible with both 32-bit and 64-bit system types. Backward compatibility with older Windows versions is ensured only by the .NET platform as specific tests were not conducted on older operating systems.

The USB protocols capabilities are defined by the Segger driver. Versions USB 2.0 and USB 3.0 are compatible.

The GUI is used to enable a communication between the sensor and the PC. The user can configure the sensor to operate in different modes. In those modes the update rate of the magnetic field measured (X, Y and Z components) and current consumption vary.

Introduction

1.3 Hardware extensions

Additionally to the provided standalone magnet there are several dedicated extensions available that can be mounted to the 3D Magnetic Sensor 2 Go kit.

Table 1 3D Magnetic Sensor 2 Go extensions

Type	Orderable part number (OPN)
Joystick	JOYSTICKFOR3D2GOKITTOB01
Rotation knob	ROTATEKNOB3D2GOKITTOB01
Linear slider	LINEARSLIDER2GOTOB01
Out of shaft	OUTOFSHAFTFOR3D2GOTOB01



Figure 2 Joystick and rotation knob extensions for the 3D Magnetic Sensor 2 Go kit

Joystick

The magnet used in the joystick extension is an axial magnetized magnet as shown in [Figure 3](#). The magnet material is ferrite, of class Y35, which is equivalent to a remanence of between 400 mT and 410 mT. The magnet disk has a size of 5 mm diameter and 5 mm thickness. For more information about the magnet, please follow this link:

https://www.supermagnete.de/eng/disc-magnets-ferrite/disc-magnet-5mm-5mm_FE-S-05-05

Introduction

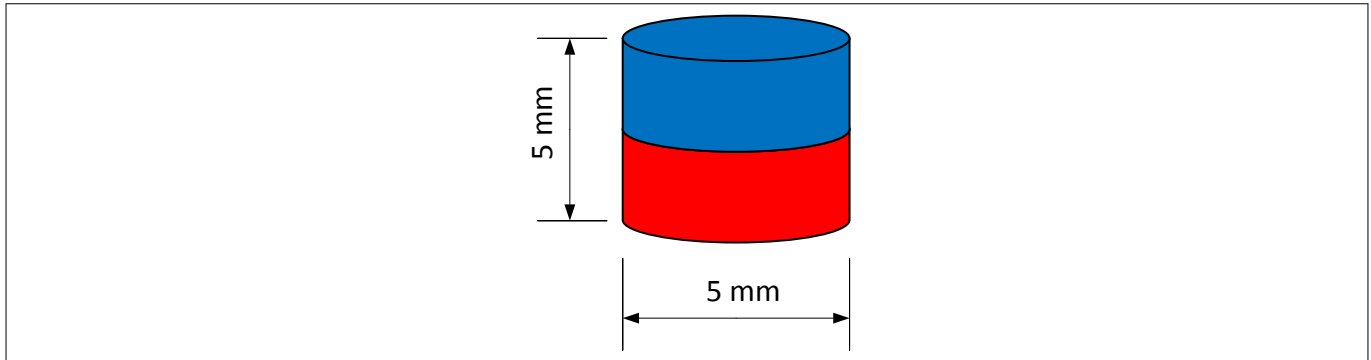

Figure 3 Magnet used in the Joystick extension

Rotation knob

The magnet used in the rotate knob extension is a diametrically magnetized magnet as shown in [Figure 4](#). The magnet material is Neodymium Iron Boron (NdFeB) of class N45. The magnet is protected against corrosion with Nickel coating (Ni-Cu-Ni). The magnet size is 4 mm diameter and 10 mm thickness. For more information about the magnet, please follow this link:

https://www.supermagnete.de/eng/rod-magnets-neodymium/rod-magnet-diameter-4mm-height-10mm-neodymium-n45-nickel-plated_S-04-10-DN

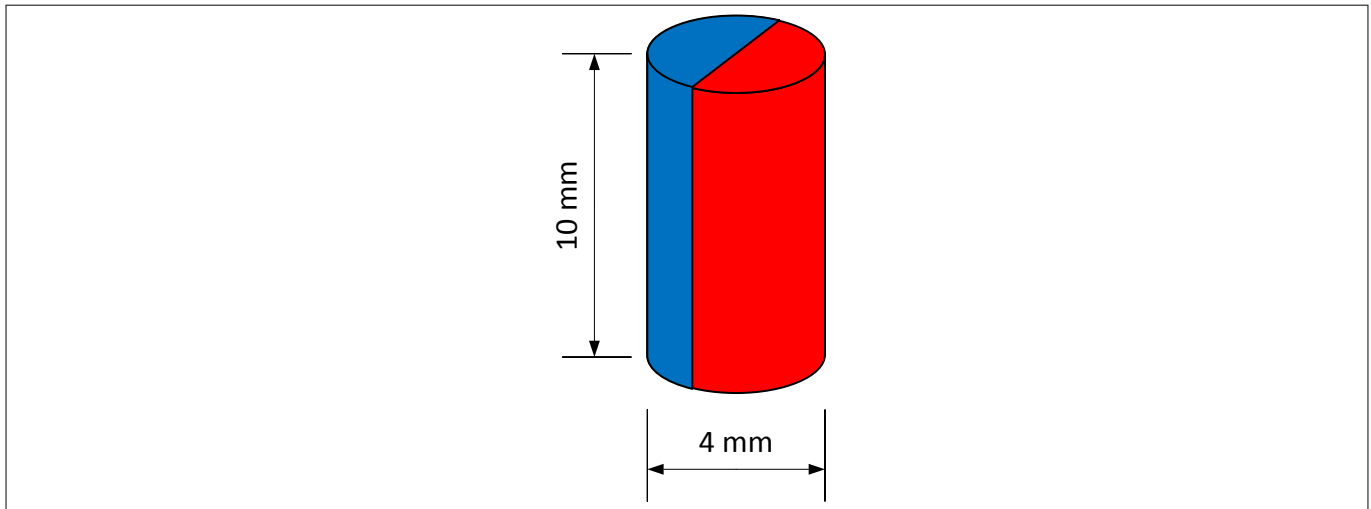

Figure 4 Magnet used in the rotation knob extension

Out of shaft

The magnet used in the out of shaft extension is a diametrically magnetized ring magnet as shown in [Figure 5](#). The magnet material is Neodymium Iron Boron (NdFeB) of class N45. The magnet is protected against corrosion with Nickel coating (Ni-Cu-Ni). The magnet size is 10 mm outer diameter, 7 mm inner diameter and 3 mm thickness. For more information about the magnet, please follow this link:

https://www.supermagnete.de/eng/ring-magnets-neodymium/ring-magnet-10mm-7mm-3mm_R-10-07-03-DN

Introduction

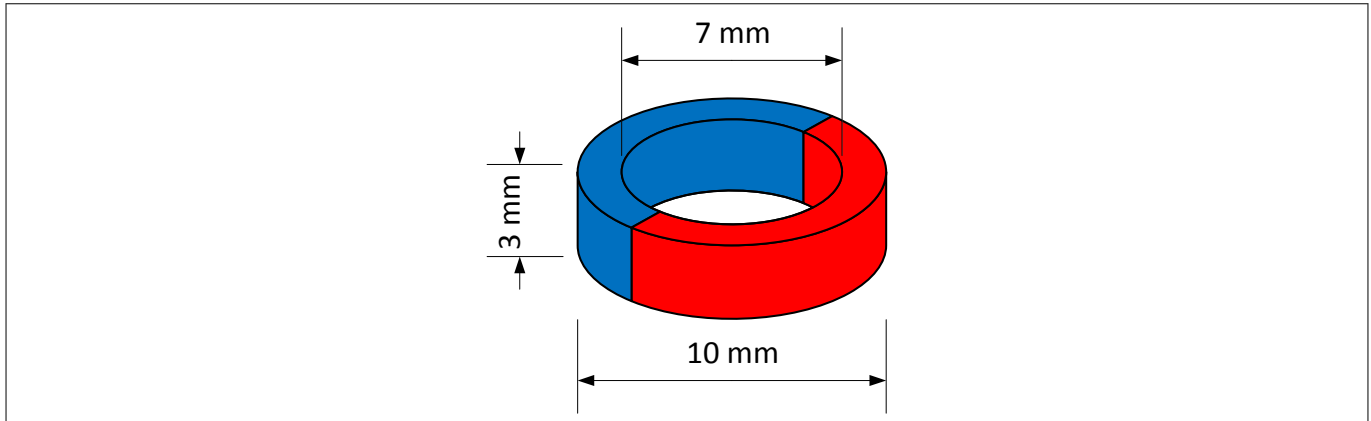

Figure 5 Magnet used in the out of shaft extension

Linear slider

The linear slider extension comes with two axial magnetized magnets of the same size as shown in [Figure 6](#). The first magnet material is Neodymium Iron Boron (NdFeB) of class N45. The magnet is protected against corrosion with Nickel coating (Ni-Cu-Ni). The second magnet material is ferrite, of class Y35, which is equivalent to a remanence of between 400 mT and 410 mT. Both magnet disk has a size of 5 mm diameter and 5 mm thickness. For more information about the magnets, please follow this links:

https://www.supermagnete.de/eng/disc-magnets-neodymium/disc-magnet-5mm-5mm_S-05-05-N

https://www.supermagnete.de/eng/disc-magnets-ferrite/disc-magnet-5mm-5mm_FE-S-05-05

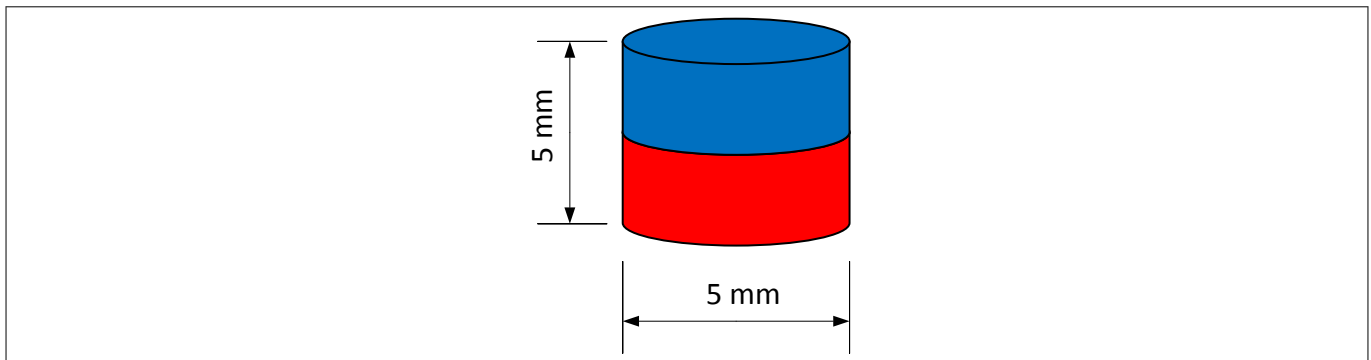

Figure 6 Magnet used in the linear slider extension

EvalBoard description

2 EvalBoard description

The evaluation board (EvalBoard) is a ready-to-use printed circuit board (PCB) which contains:

- The 3D magnetic sensor TLE493D-A2B6. For the availability of 3D Magnetic Sensor 2 Go kits with different sensor variants check the Infineon web page: <https://www.infineon.com/cms/en/product/sensor/magnetic-sensors/magnetic-position-sensors/3d-magnetics/>
- XMC1100 microcontroller based on ARM Cortex™-M0 at 48 MHz frequency connected to the 3D sensor.
- XMC4200 microcontroller based on ARM Cortex™-M4 at 144 MHz frequency used for debugging and USB communication.
- Micro USB connector for power supply and communication with the Graphical User Interface (GUI).
- LED for indication of power supply and debugging.
- Two LEDs for user configuration.
- Voltage regulator, reverse current protection diode and ESD protection diode.
- Pin headers to access data lines (e.g. via oscilloscope, external microcontroller).

The different components and its location are shown in **Figure 7**. The 3D magnetic sensor can be separated from the rest of the EvalBoard by cutting the break line.

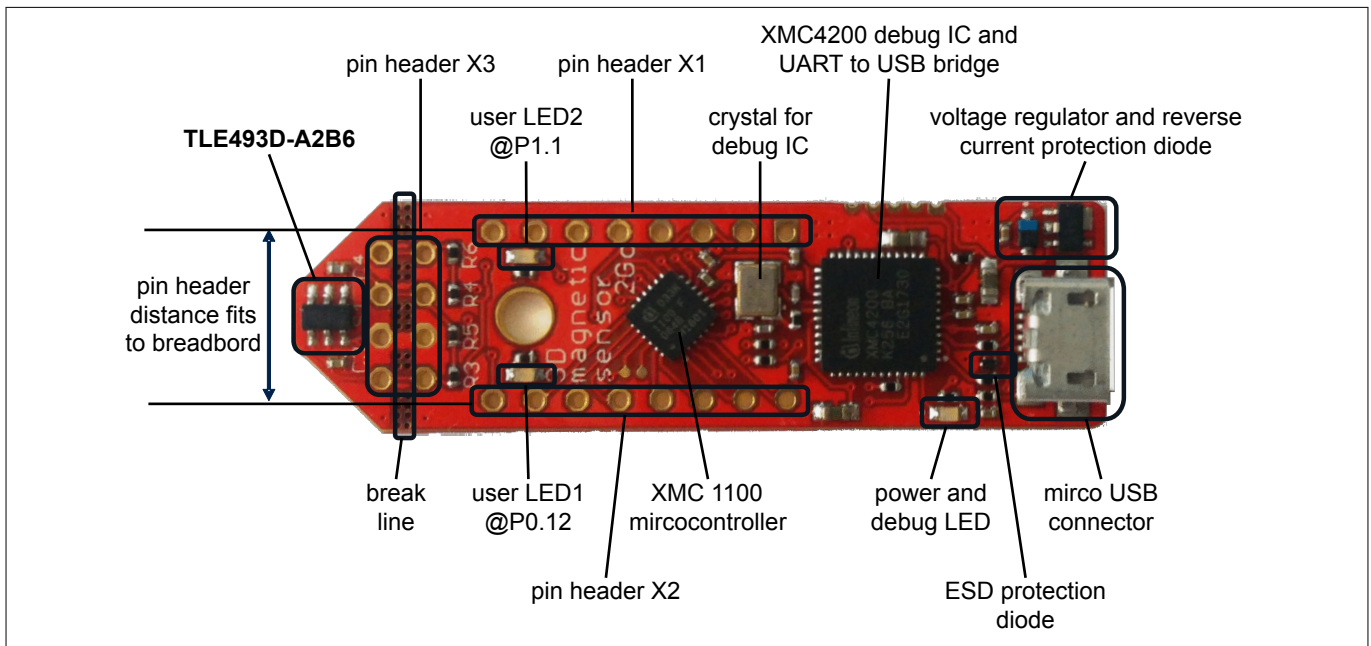

Figure 7 Main components of the EvalBoard

2.1 Optional external power supply

The 3D Magnetic Sensor 2 Go EvalBoard is supplied via the USB cable. It is also possible to provide an external power supply. If this is the case, a few considerations must be taken into account as described below.

The 3D Magnetic Sensor 2 Go EvalBoard must be supplied by external 5 Volt DC power supply connected to the micro USB plug. The voltage regulator shifts the voltage level to 3.3 V for the microcontrollers and the 3D magnetic sensor. The Power & Debug LED indicates that the presence of the generated 3.3 V supply voltage.

Out of the box with the pre-programmed application and the on-board debugger in operation the EvalBoard typically draws about 75 mA. This current can be delivered via the USB plug of a PC, which is specified to deliver up to 500 mA. An on-board reverse current protection diode will ensure safe operation and protects the USB port of the Laptop/PC in case power is provided through the pin header X1.

EvalBoard description

It is not recommended to apply an additional power supply to the V_{DD} pin of X1 (3.3 V) when the board is powered via USB, because the 3.3 V supply could drive against the on-board power supply. The V_{DD} pin can be used to power an external circuit. But care must be taken not to draw more current than 150 mA, which is the maximum current the on-board voltage regulator can deliver. After power-up the Debug LED starts blinking. In case there is connection to a PC with correctly installed drivers, the Debug LED will turn from blinking to constant illumination.

2.2 Pin header connector

The pin headers X1 and X2 can be used to extend the evaluation board or to perform measurements on the XMC1100. The order of pins available at X1 and X2 corresponds to the pinning schema of the XMC1100 microcontroller in the TSSOP-16 pin package. The pinning table is also printed onto the bottom side of the PCB (depending on the version). The pin header X3 can be used to access directly the 3D magnetic sensor pins.

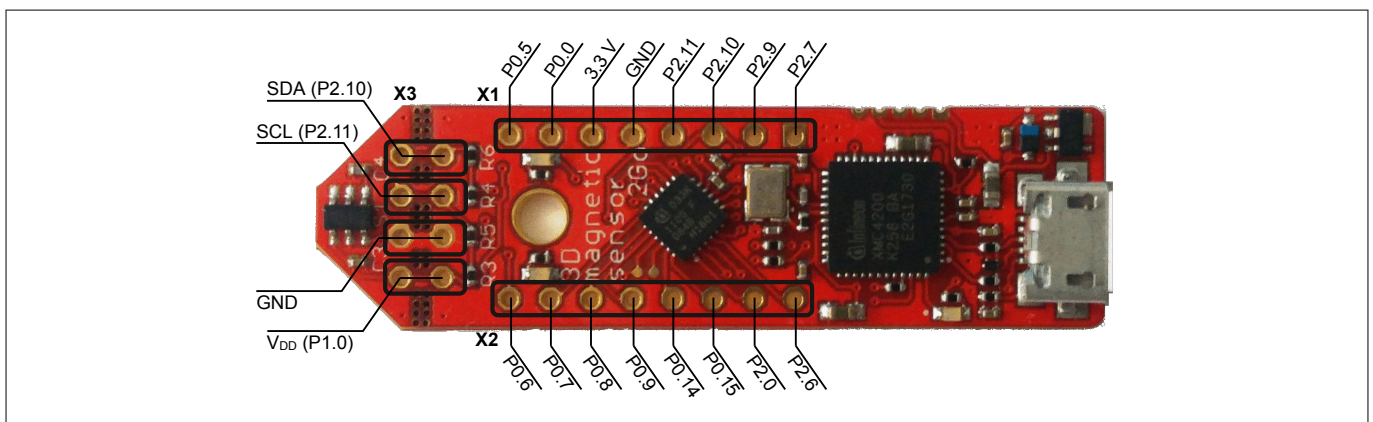

Figure 8 EvalBoard pin header connectors

The 3D Hall sensor pins can be accessed via the pin headers as shown in [Table 2](#).

Table 2 Pin header description for the 3D magnetic sensor (X3)

TLE493D-A2B6 pin number	Pin name on board	XMC1100 port pin	Sensor pin description
1	SCL	P2.11	Interface clock and \INT pin, open drain
3	GND	GND	Ground pin
4	+3V3	P1.0	Supply pin
6	SDA	P2.10	Interface data pin, open drain

The XMC1100 port pins P0.12 and P1.1 are connected the two user LEDs and are not available on the pin headers.

Table 3 Pins used for the user LEDs

LED	XMC1100 port pin
LED1	P0.12
LED2	P1.1

EvalBoard description

2.3 EvalBoard schematics

The schematics of the different blocks from the EvalBoard of the 3D Magnetic Sensor 2 Go kit are provided in this chapter. They can be used to design customized PCBs. The user (integrator) is responsible for the correct functioning on system level as well as for the validation and testing.

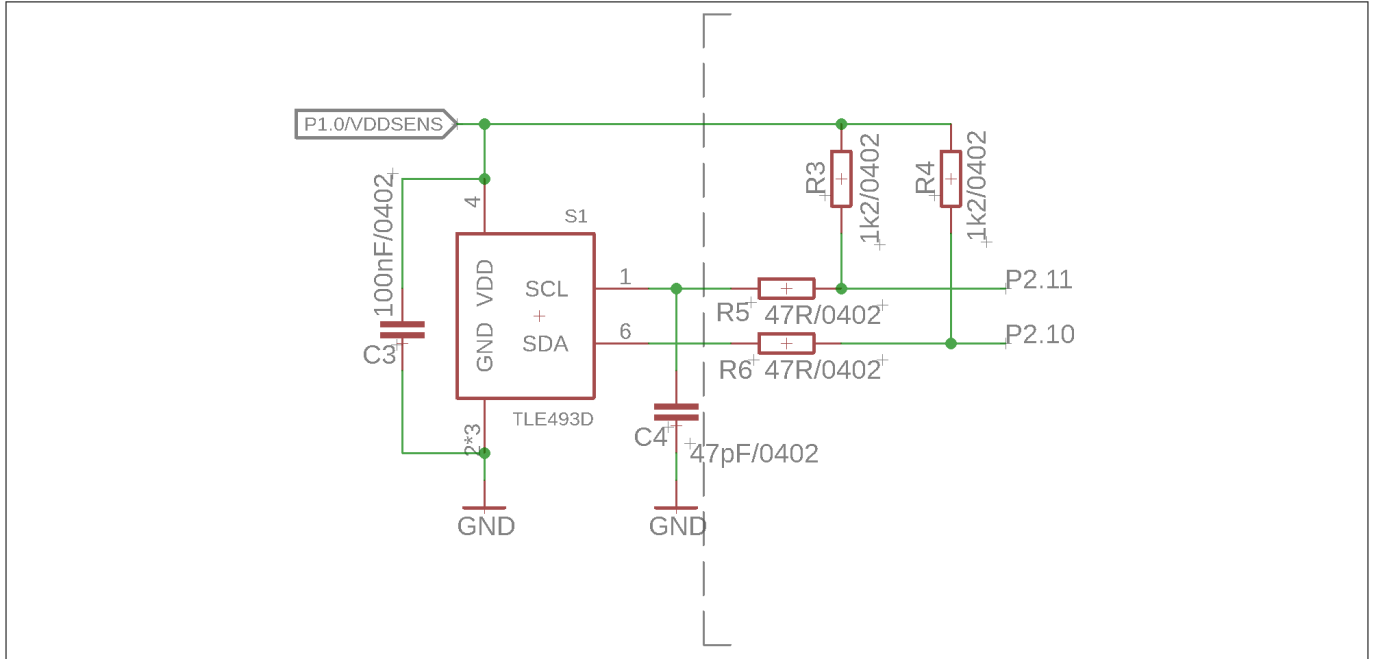

Figure 9 EvalBoard schematic: 3D magnetic sensor

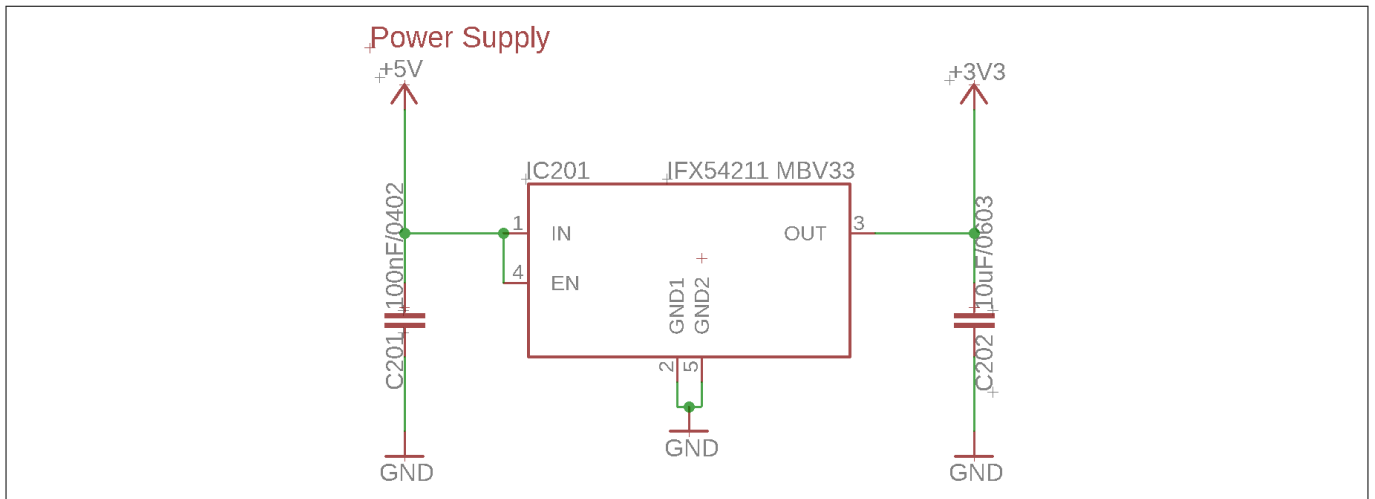

Figure 10 EvalBoard schematic: the voltage regulator (for the power supply)

EvalBoard description

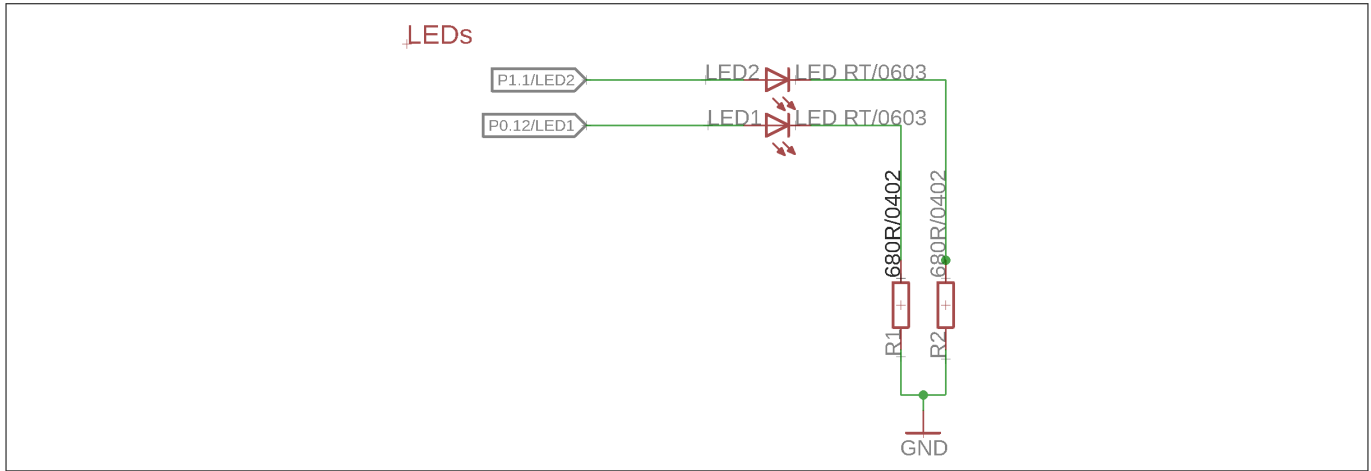

Figure 11 EvalBoard schematic: the LEDs for user configuration (connected to XMC1100 pins)

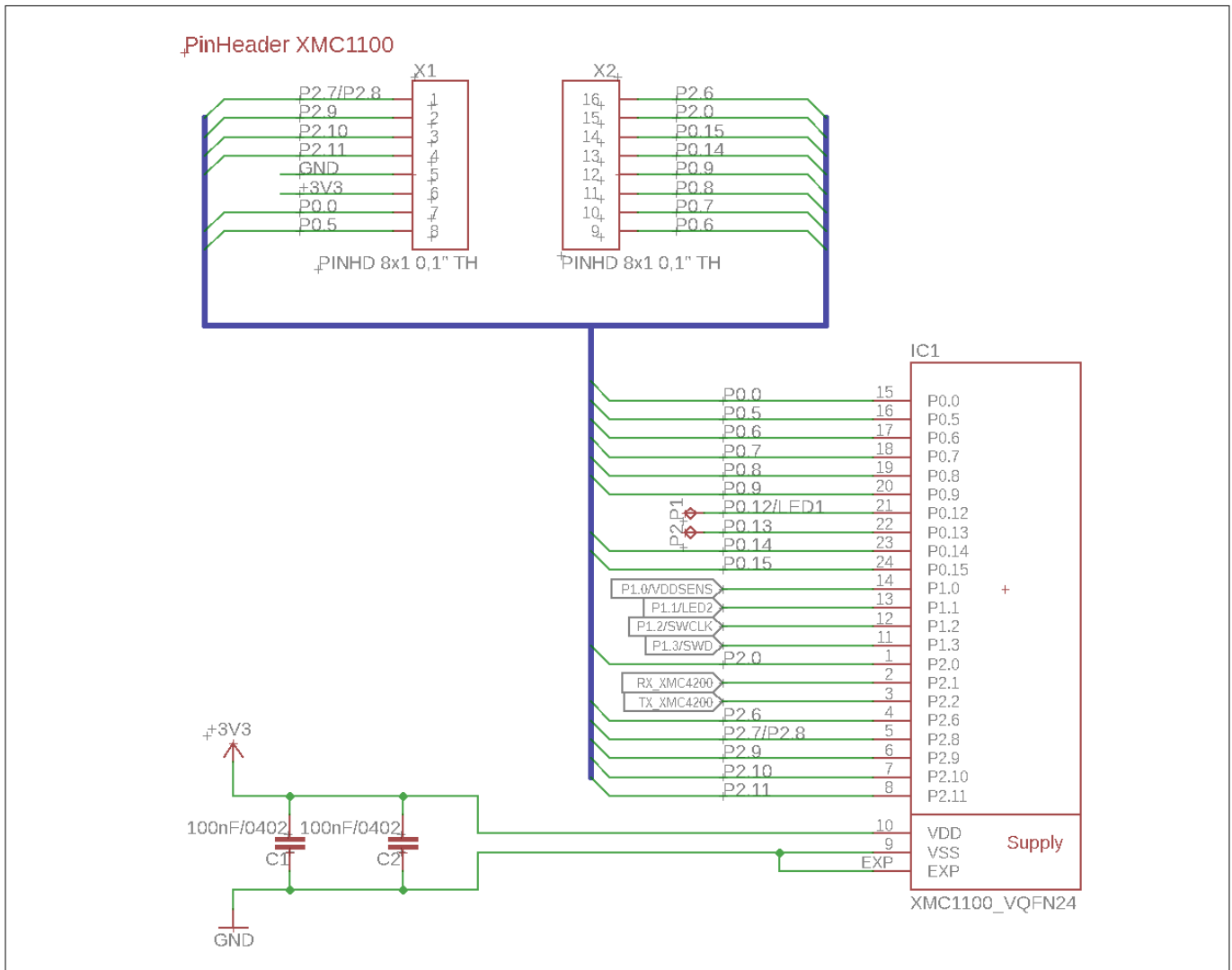

Figure 12 EvalBoard schematic: the XMC1100 microcontroller and pin headers

EvalBoard description

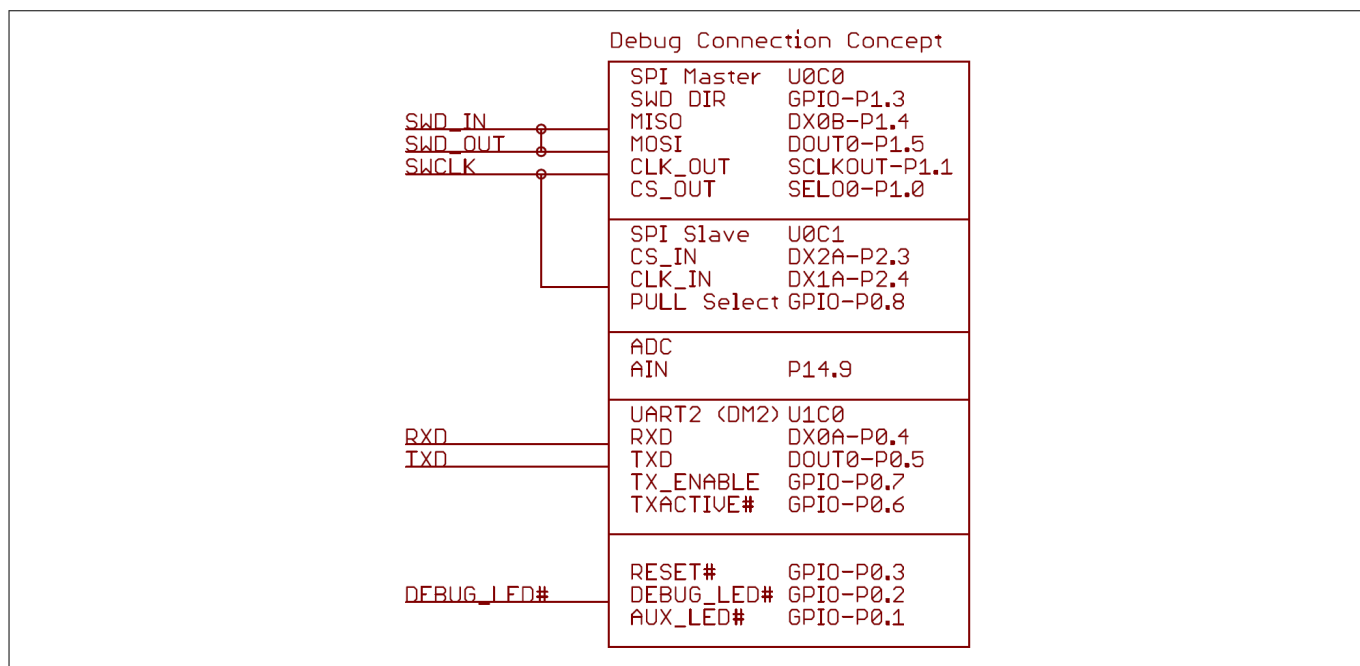

Figure 13 **Sketch of the debug connection**

EvalBoard description

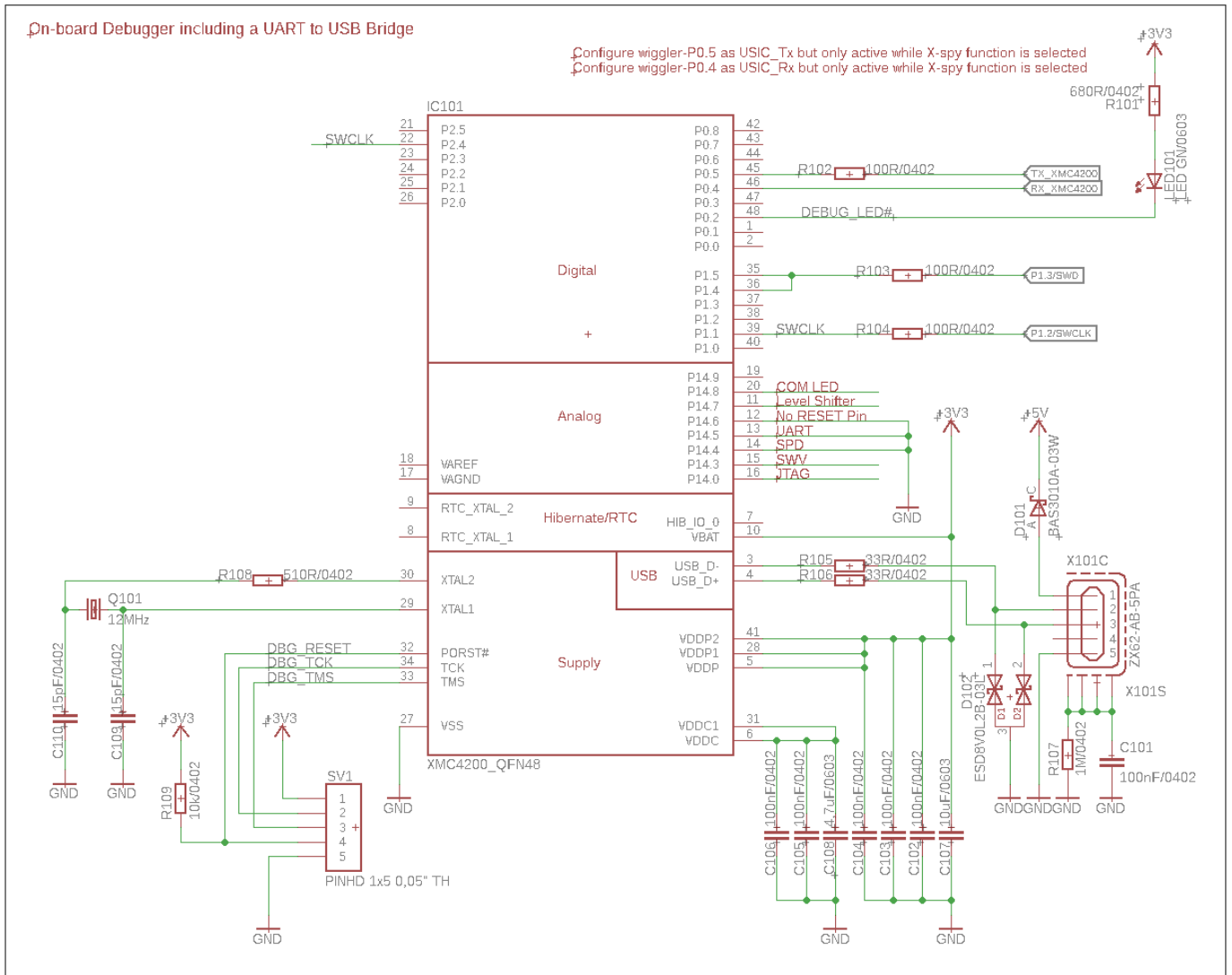

Figure 14 EvalBoard schematic: the XMC4200 microcontroller and micro USB connector

Software installation

3 Software installation

The following description guides through the installation procedure of the free evaluation software for the 3D Magnetic Sensor 2 Go kit.

Steps

1. Download the software.

Follow the link below to reach the **Sensor 2 Go** information page on the Infineon website. As shown in **Figure 15**, you can find the download link for the latest version of the 3D Magnetic Sensor 2 Go GUI on the right hand side.

<https://www.infineon.com/cms/en/product/promopages/sensors-2go/>

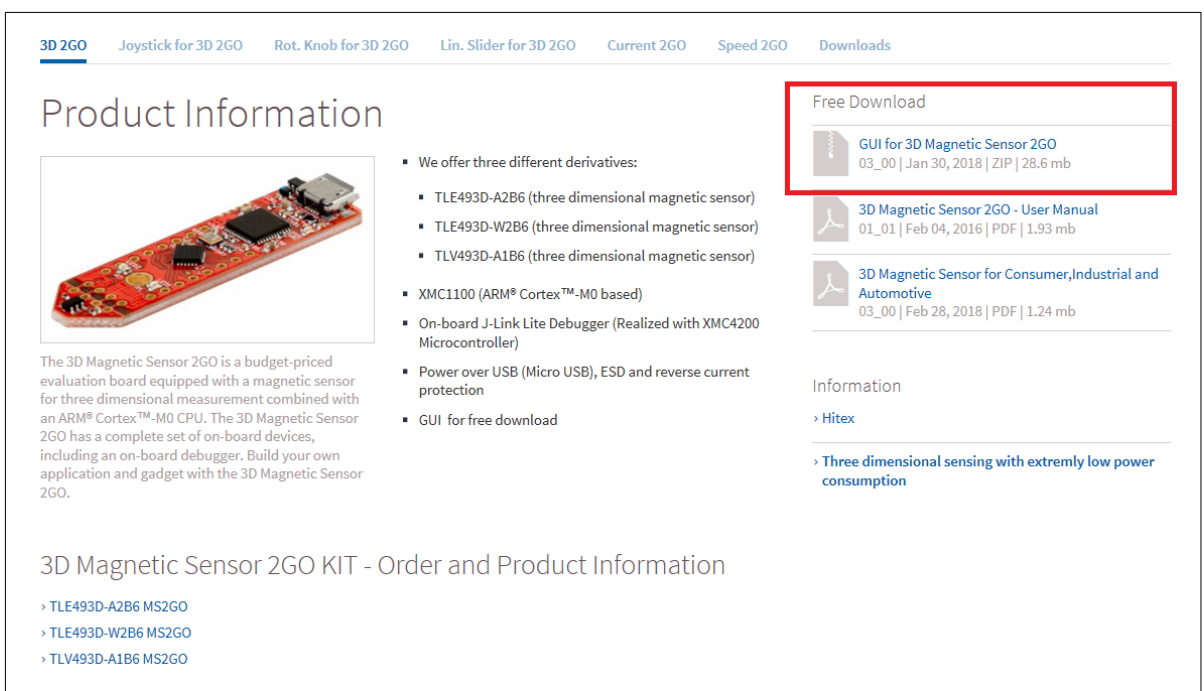

Figure 15 Download the "3D Magnetic Sensor 2 Go" software from the Infineon web page

2. Start the installation process.

Browse to your download folder and extract the downloaded .zip file. Afterwards, double click on the .msi file to start the installer. The window in **Figure 16** pops up. Click "Next".

Software installation

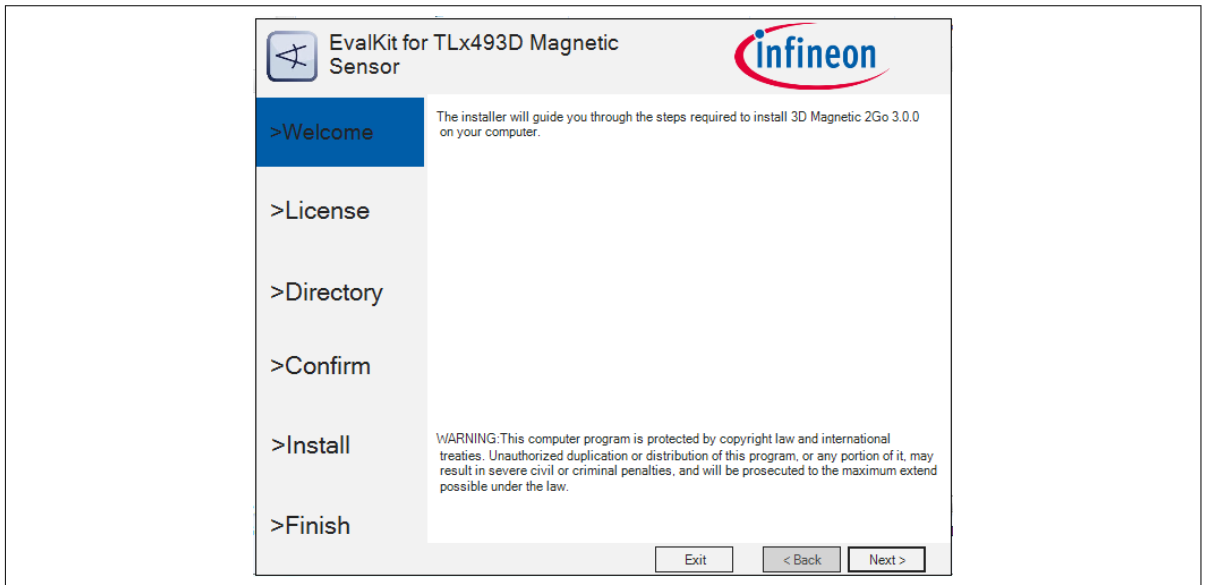

Figure 16 Start the software installation

3. Read the license agreement carefully and tick the box to accept the terms. Click **Next**.

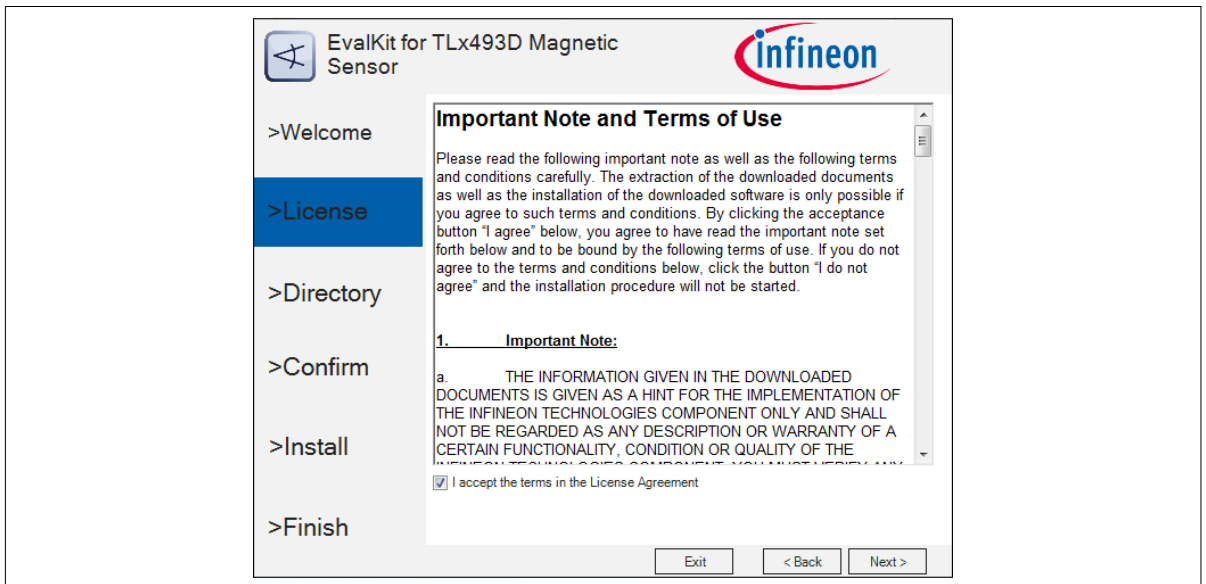

Figure 17 Accept the license agreement

4. Choose your installation path. The software requires the SEGGER J-Link driver and .NET framework version 4.5 or later to be installed on your PC. If not yet available, check the respective items. Click **Next**

Software installation

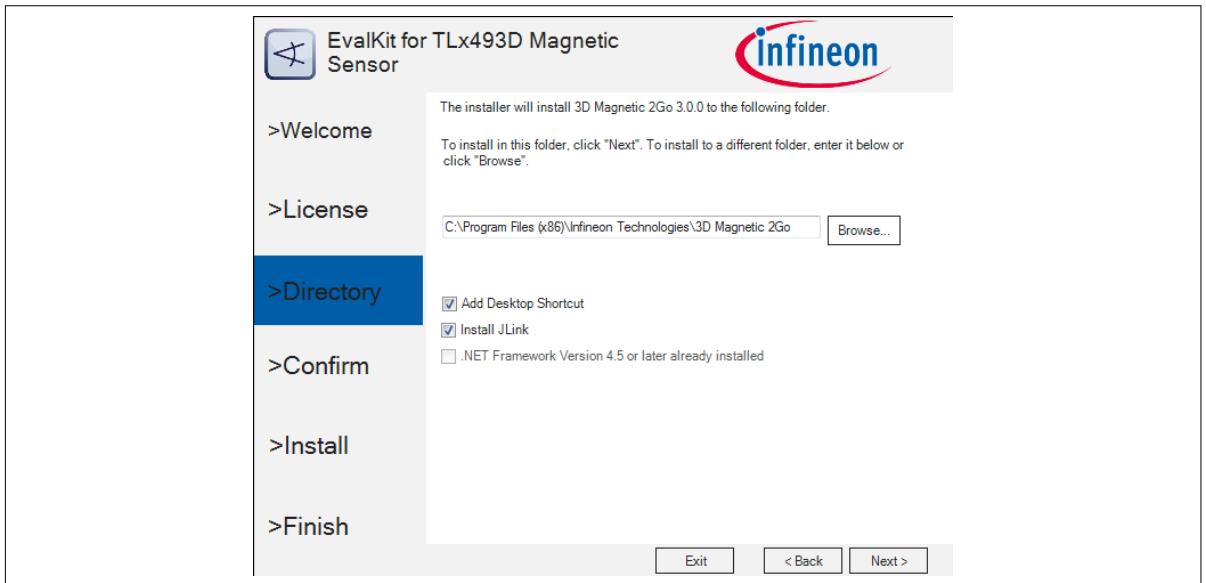

Figure 18 Select you installation folder

5. Confirm the installation settings by clicking on **Install**.

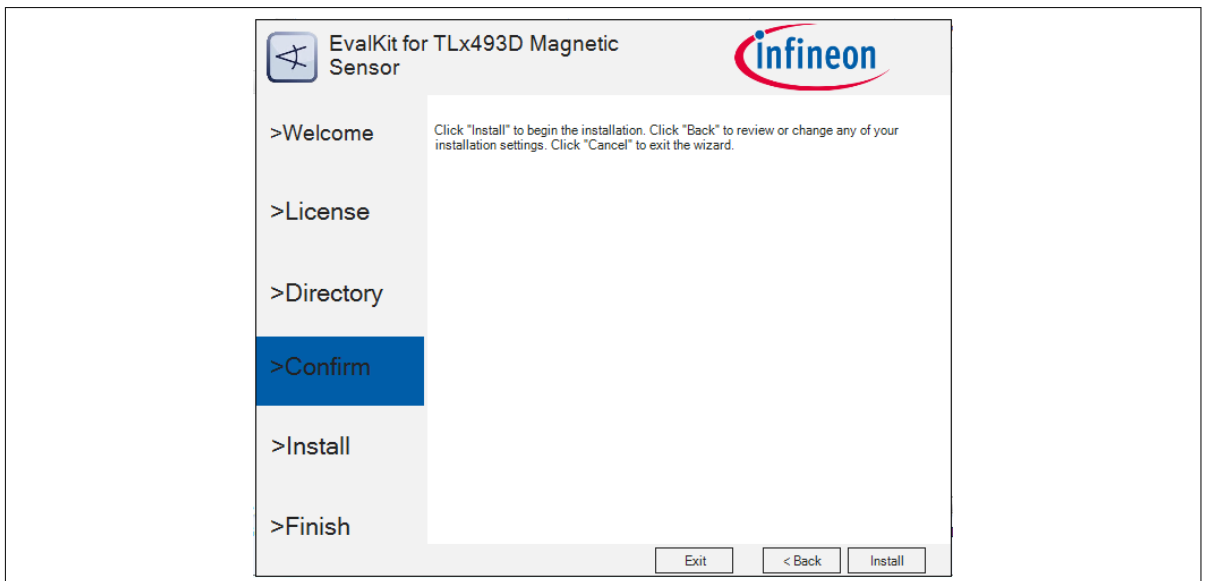

Figure 19 Confirm the installation

6. Once the installation is complete, click on **Finish** to close the installer.

Software installation

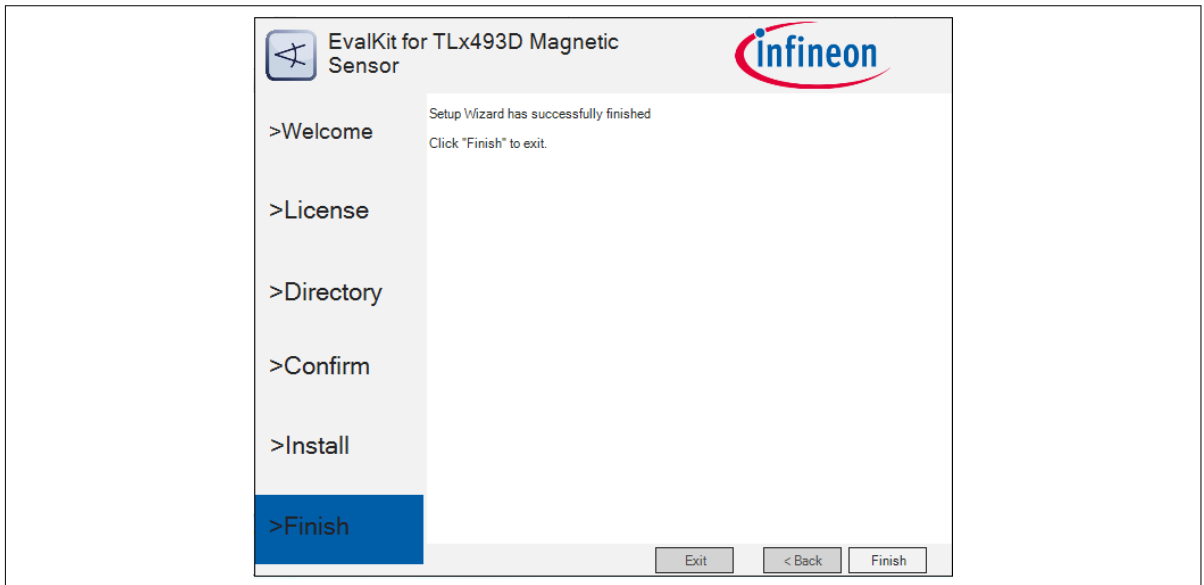

Figure 20 Installation finished

7. You can now start the evaluation software. Open the start menu, browse to **Infineon Technologies > 3D Sensor 2go Kit** and open the application by clicking on **3D 2Go**.

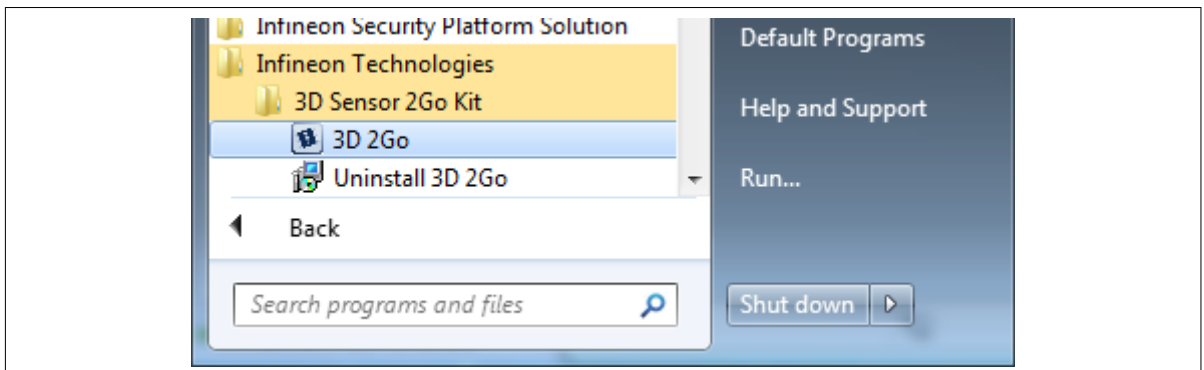

Figure 21 Shortcut to the 3D Magnetic 2Go evaluation software (GUI)

3.1 Driver installation

To enable the communication between the 3D Magnetic Sensor 2 Go kit it is necessary to install the J-Link driver on your PC.

The driver is included in the GUI installer and will start automatically within the installation progress. In case of issues, you can directly download the latest version from the SEGGER homepage:

<https://www.segger.com/downloads/jlink>

Steps

1. Start the installation. Invoke your downloaded driver executable or wait for the 3D Magnetic Sensor 2 Go installer to open the window shown in [Figure 22](#). Click on **Next**.

Software installation



Figure 22 J-Link driver setup

2. Read and accept the license agreement. Click on **I Agree**.

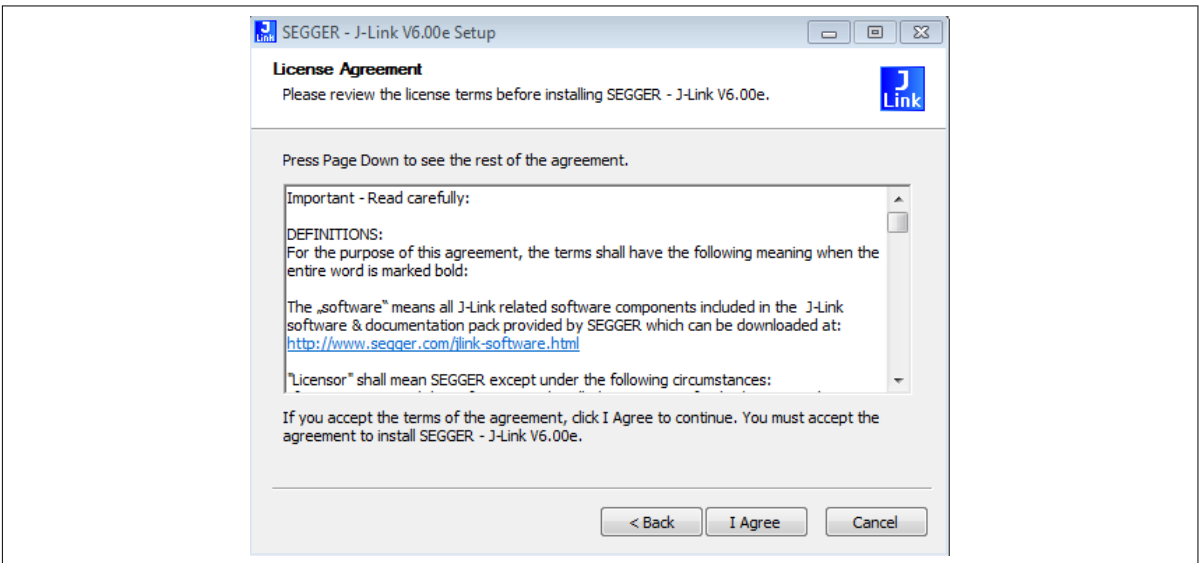

Figure 23 J-Link license agreement

3. Check that the "Install USB Driver for J-Link" option is active. Click on **Next**.

Software installation

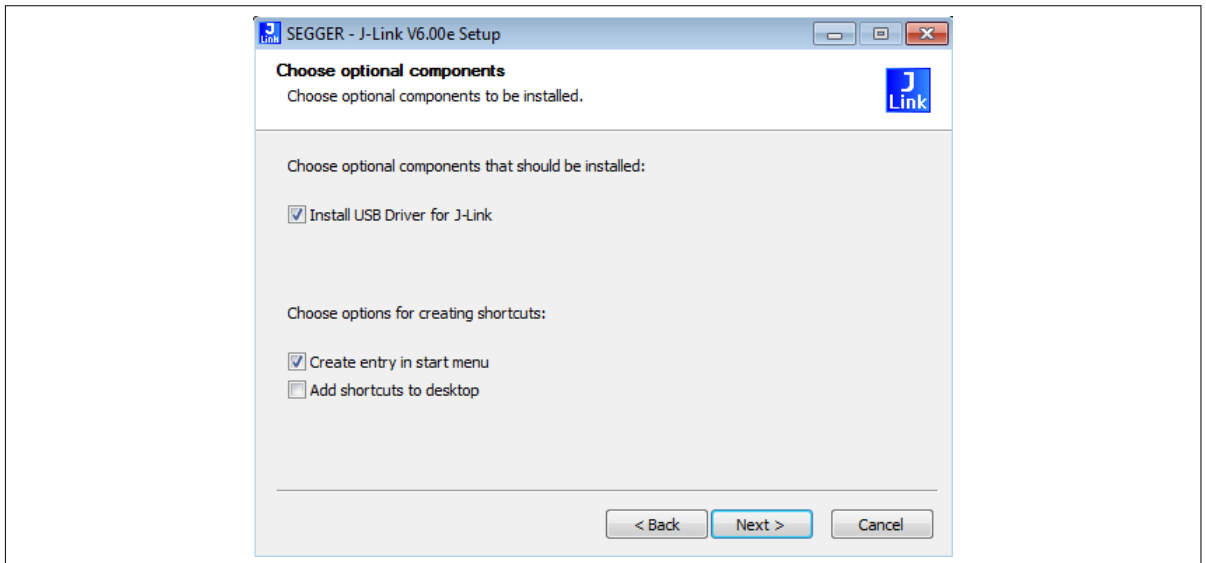

Figure 24 J-Link installation options

4. Choose the installation folder. It is recommended to keep the default settings. Click on **Install**. Now the installation should be executed.

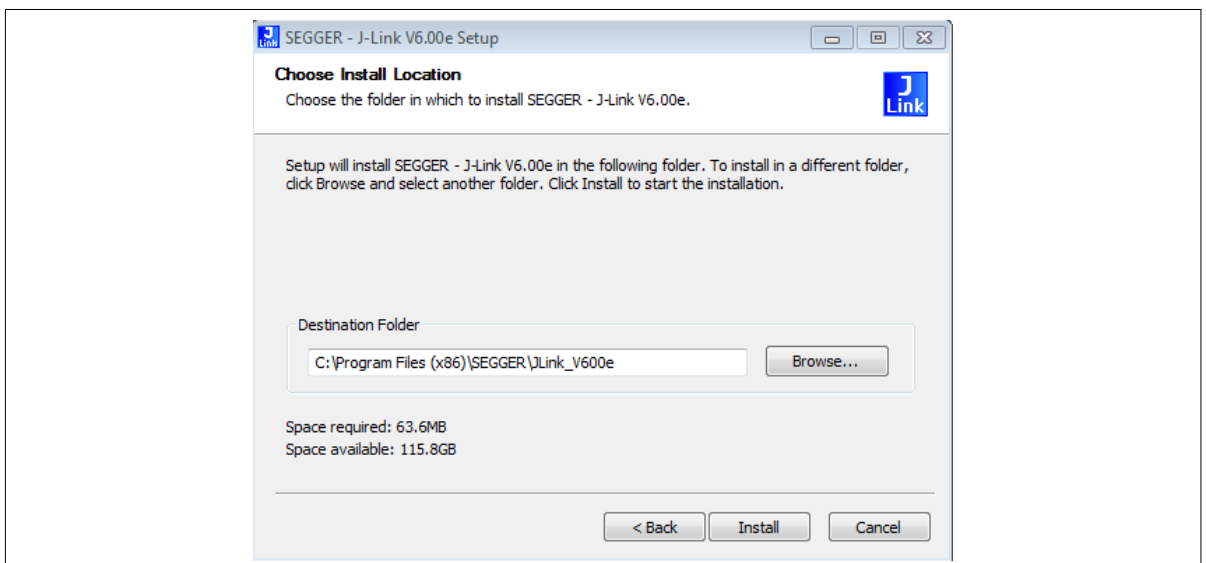

Figure 25 J-Link choose install location

5. Once the installation is completed, close the installer by clicking on **Finish**.

Software installation



Figure 26 J-Link installation complete

3D magnetic sensor evaluation

4 3D magnetic sensor evaluation

This chapter describes how the GUI can be used to make first evaluations with Infineon's 3D magnetic sensor.

4.1 Getting started

Once the software is installed, the following steps are necessary to do the first magnetic measurements.

Steps

1. Connect the EvalBoard to the PC via the USB cable. Use the micro USB port for the EvalBoard and USB port for the PC. The power LED on the EvalBoard will switch on, indicating the EvalBoard is supplied with enough power.
2. Open the 3D 2Go GUI by clicking the shortcut in the start menu. On the top left side you should find the XMC2Go board in the list. If not, check that the EvalBoard is correctly connected to the PC and the J-Link driver is installed. Click on the **Connect to selected programmer button** which is marked in [Figure 27](#) to establish the connection with the 3D Magnetic Sensor 2 Go kit. The first time you connect the board, a firmware will be downloaded to the XMC1100 which takes short time. This is indicated by the blinking power LED on the EvalBoard.

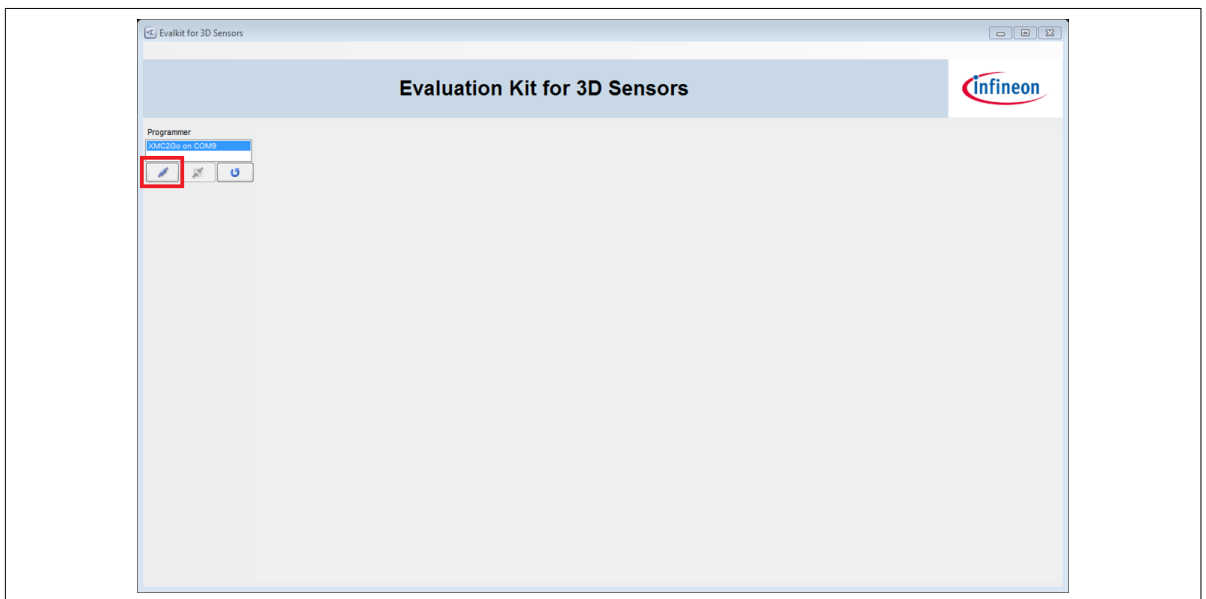

Figure 27 Establish the connection to the EvalBoard

3. The GUI automatically detects the sensor type on the 3D Magnetic Sensor 2 Go kit. Different configuration modes can be selected which are briefly described in [Table 4](#) . For details refer to the TLE493D-A2B6 data sheet and user manual. After you have selected the mode, click on **Start** to begin with the measurements.

Table 4 Sensor modes

Sensor mode	Description
Low power mode	Cyclic sensor measurements with a configurable update rate. The GUI sets the sensor to the default update rate of 770 Hz (typ.). Between the measurements, the sensor stays in power down mode, which reduces the power consumption.
Fast mode	Sensor measurements are running continuously. Fastest update rate.

3D magnetic sensor evaluation

Table 4 Sensor modes (continued)

Sensor mode	Description
Master controlled mode	Sensor measurements are triggered by the microcontroller, which enables high flexibility.

4.2 Graph View

The graph view displays the magnetic field measurements in X, Y and Z direction.

Figure 28 shows the graph view window. On the left hand side there are three histograms which plot the magnetic field for each measured sample. On the right a table displays all measured data, including the temperature. With the **save** button it is possible to export the measurement data into a .csv file. This is especially helpful for processing the data afterwards. .

If a new mode should to be evaluated click the **Stop** button on the left control panel. **Save** the data and **Clear** it. Select a new configuration and click again on **Start** to begin the new evaluation.

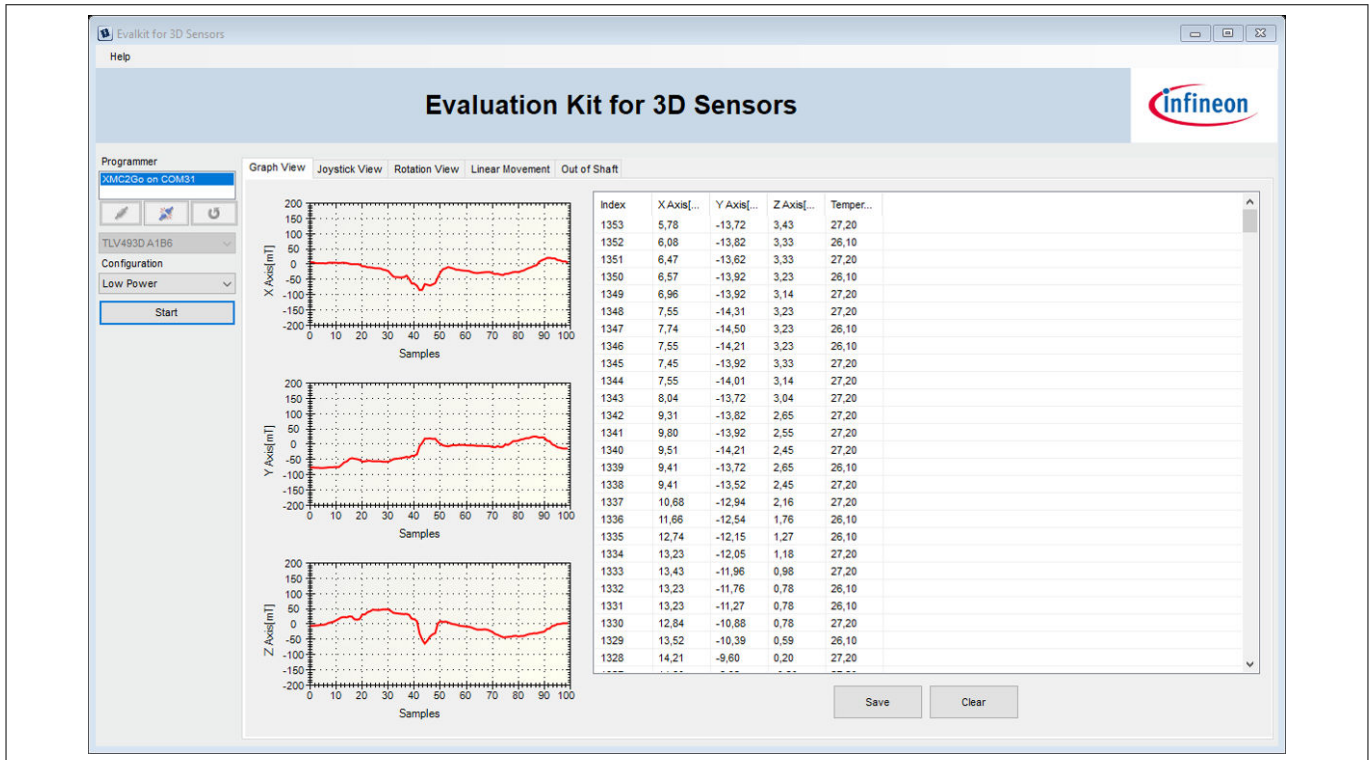

Figure 28 Graph view

3D magnetic sensor evaluation

4.3 Joystick view

The joystick view is a virtual representation of a real joystick with an attached magnet, mounted above the 3D magnetic sensor.

It is intended to be used with the Joystick adapter available for the 3D Magnetic Sensor 2 Go kit. For order details and information about the used magnet refer to section [Hardware extensions](#).

The software measures the magnetic field in all three dimensions and calculates the angles necessary to determine the joystick position. Further information is given in the application note "Infineon 3D Magnetic Sensor - How to Make a Magnetic Design for Joystick" which can be found on the Infineon home page.

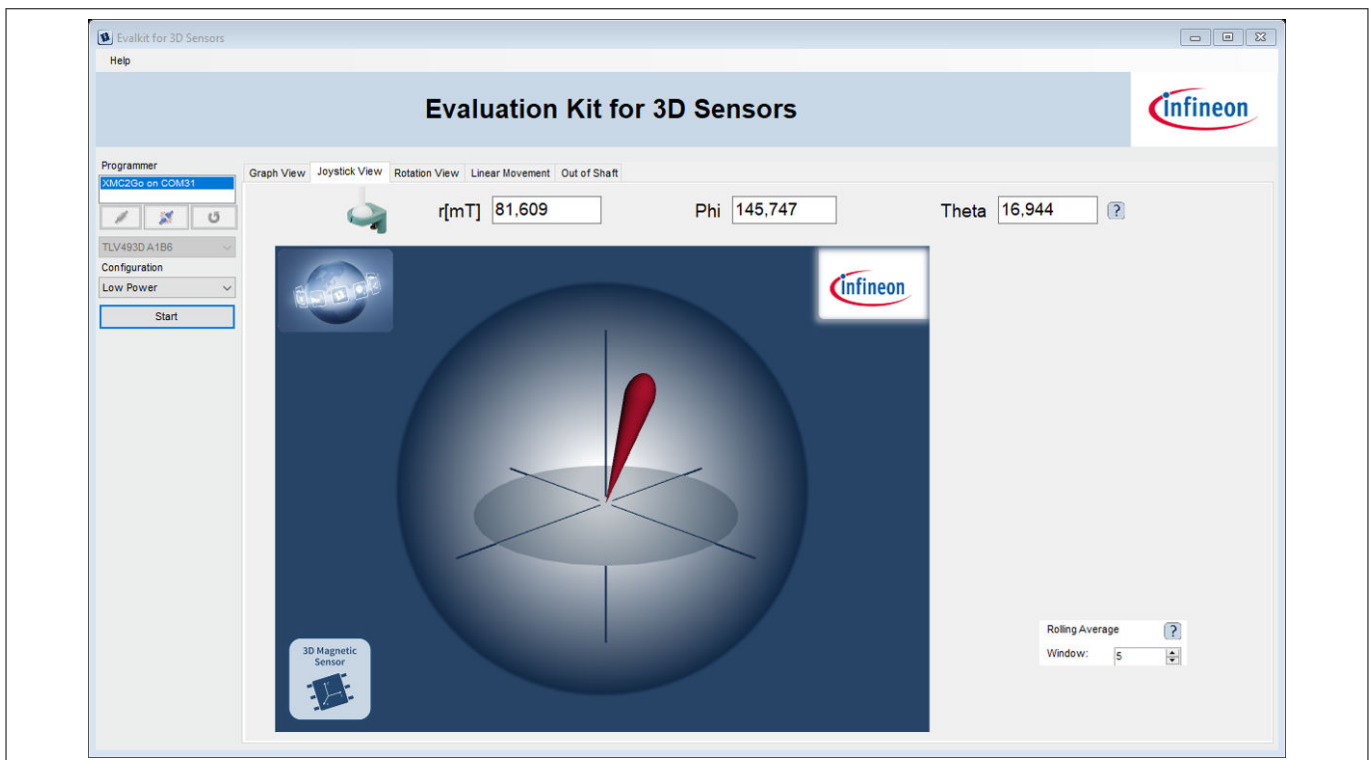

Figure 29 Joystick view

4.4 Rotation view

In this view the calculated spherical coordinates of the magnetic field are displayed. Additionally it includes a graphical presentation of the 3D Magnetic Sensor 2 Go rotary knob attachment.

The polar coordinates consist of the radius r as well as the angles Phi and Theta. They are calculated out of the measured three dimensional magnetic field with following equations:

$$r = \sqrt{B_x^2 + B_y^2 + B_z^2}$$

$$\text{Phi} = \arccos \frac{B_z}{r}$$

$$\text{Theta} = \arctan \frac{B_y}{B_x}$$

Below the polar coordinates a virtual rotation knob can be found. It can be used with the rotary knob attachment described in [Hardware extensions](#). When the user turns the hardware knob, also the indicator in the GUI turns. This is achieved by measuring the magnetic field and calculating the angle between Bx and By as described above. Also a push functionality is implemented depending on the radius r of the magnetic field.

3D magnetic sensor evaluation

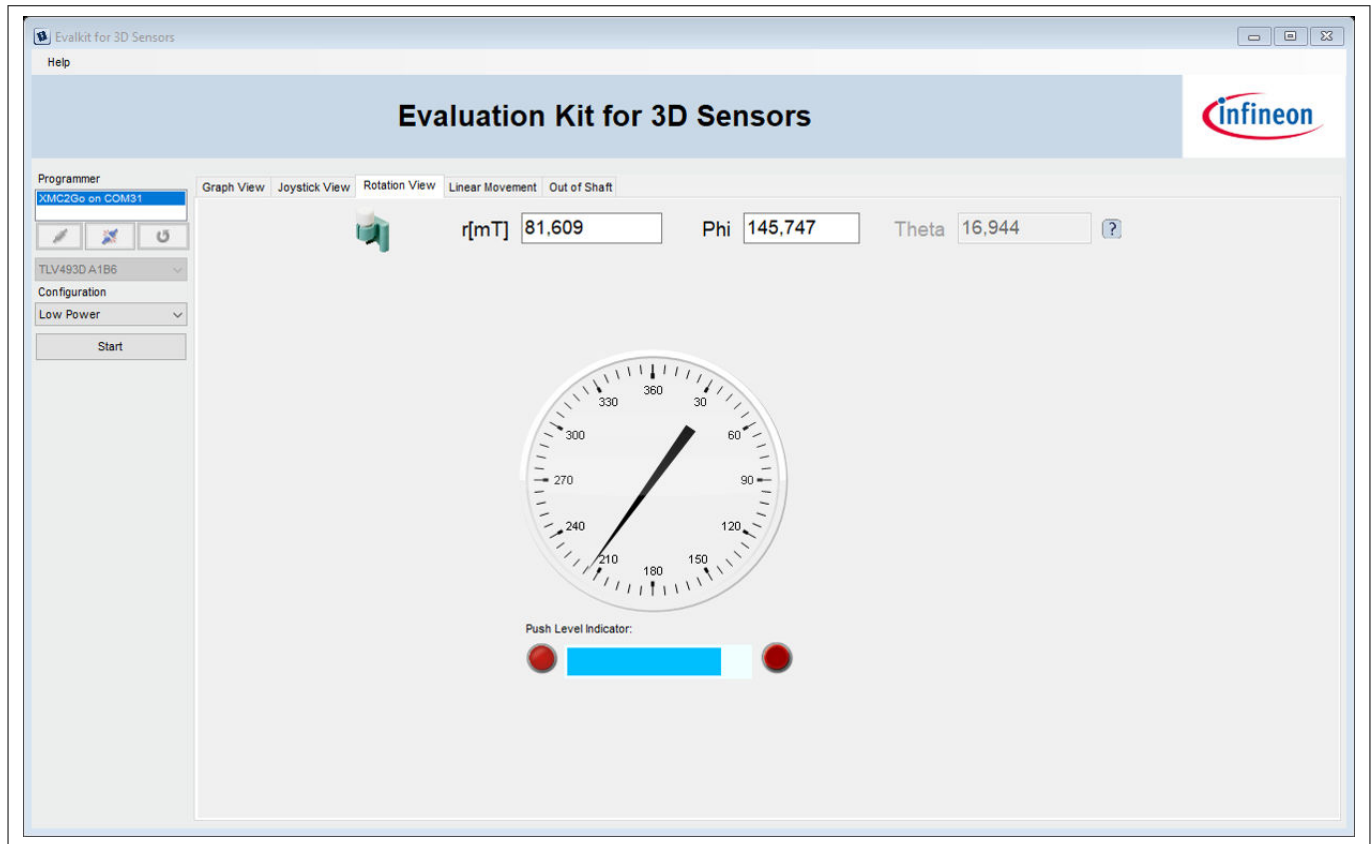

Figure 30 Polar coordinates

4.5 Linear movement

This view is meant to be used with the linear slider extension. It allows to measure the position of the magnet in a slide by configuration.

For details have a look on the video "3D magnetic sensor linear slider adapter for sensor 2GO Kits" on the following page:

<https://www.infineon.com/cms/en/product/promopages/sensors-2go/#Add-ons-3D-Magnetic-2GO>

3D magnetic sensor evaluation



Figure 31 **Linear movement view**

4.6 **Out of shaft**

This view is meant to be used with the out of shaft extension. It allows to measure the angle of the magnet while the sensor is placed at the side of it.

For details have a look on the video "3D magnetic sensor out of shaft adapter angle measurement" on the following page:

<https://www.infineon.com/cms/en/product/promopages/sensors-2go/#Add-ons-3D-Magnetic-2GO>

3D magnetic sensor evaluation

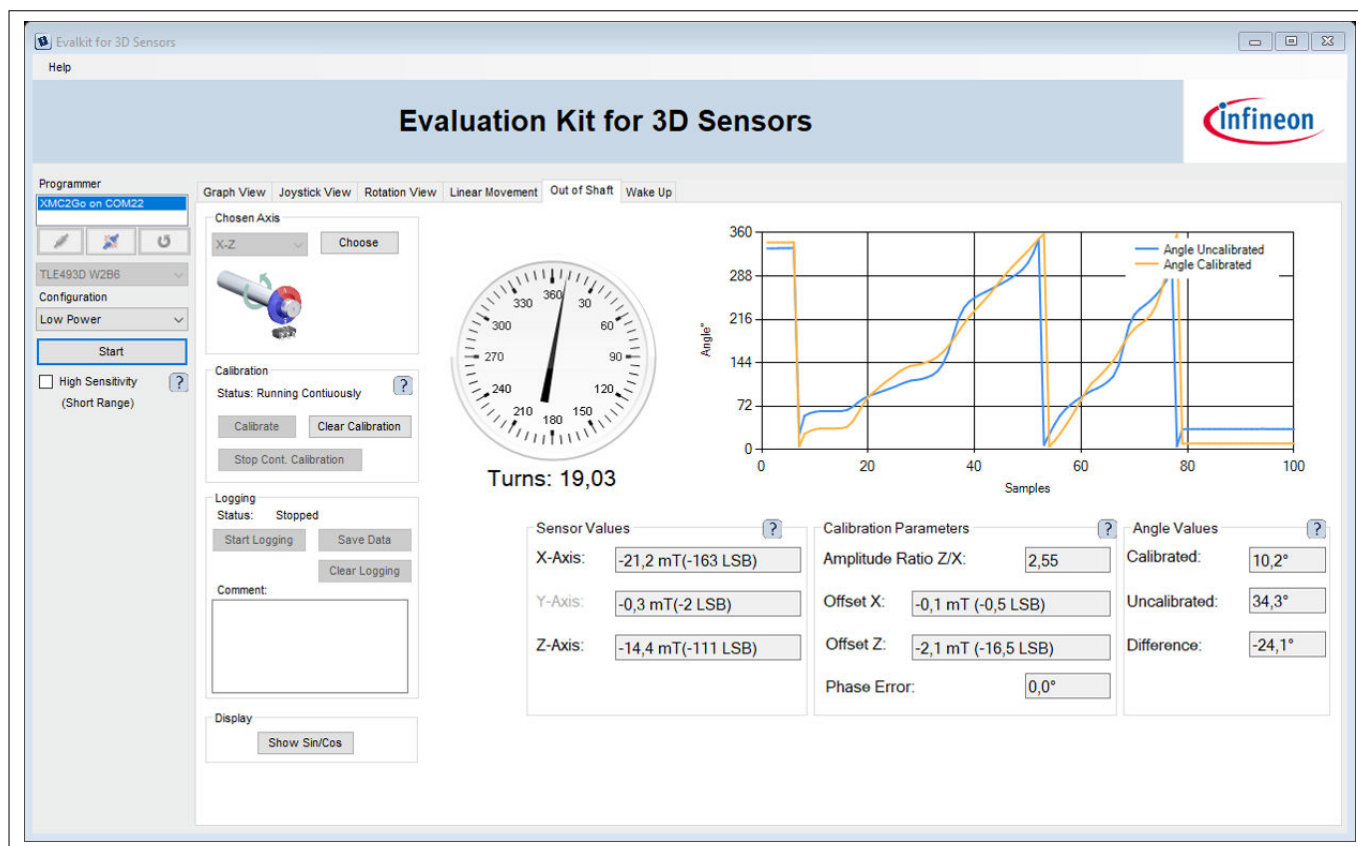

Figure 32 **Out of shaft view**

5 Example code for developers

Additionally to the graphical user interface a low level library is provided as a quick entry point for own developments with the 3D magnetic sensor. It can be downloaded from the link below.

<https://www.infineon.com/cms/de/product/sensor/magnetic-sensors/magnetic-position-sensors/3d-magnetics/#!tools>

The library comes with a generic C code example as well as a specific implementation for the XMC based 3D Magnetic Sensor 2 Go kit. An comprehensive documentation can be found under the respective "doc" folder. For the html version open the "index.html" file with your browser.

6 XMC for Arduino

Finally, the 3D Magnetic Sensor 2 Go kit can be used in combination with the Arduino IDE. A library is provided to enable a fast evaluation in the individual application. More details and the download can be found at the link below:

<https://github.com/Infineon/TLE493D-3DMagnetic-Sensor>

Revision history

Revision history

Document version	Date of release	Description of changes
1.0	2018-05-16	Initial version
1.1	2018-10-12	Title page updated
1.2	2019-09-06	Updated section <i>Hardware extensions</i> Added new view descriptions to the section <i>3D magnetic sensor evaluation</i> Added <i>XMC for Arduino</i> Added <i>Example code for developers</i> Various editorial changes

Trademarks

All referenced product or service names and trademarks are the property of their respective owners.

Edition 2019-09-06

Published by
Infineon Technologies AG
81726 Munich, Germany

© 2019 Infineon Technologies AG
All Rights Reserved.

Do you have a question about any
aspect of this document?
Email: erratum@infineon.com

Document reference
IFX-hda1518789688364

IMPORTANT NOTICE

The information given in this document shall in no event be regarded as a guarantee of conditions or characteristics ("Beschaffheitsgarantie").

With respect to any examples, hints or any typical values stated herein and/or any information regarding the application of the product, Infineon Technologies hereby disclaims any and all warranties and liabilities of any kind, including without limitation warranties of non-infringement of intellectual property rights of any third party.

In addition, any information given in this document is subject to customer's compliance with its obligations stated in this document and any applicable legal requirements, norms and standards concerning customer's products and any use of the product of Infineon Technologies in customer's applications.

The data contained in this document is exclusively intended for technically trained staff. It is the responsibility of customer's technical departments to evaluate the suitability of the product for the intended application and the completeness of the product information given in this document with respect to such application.

WARNINGS

Due to technical requirements products may contain dangerous substances. For information on the types in question please contact your nearest Infineon Technologies office.

Except as otherwise explicitly approved by Infineon Technologies in a written document signed by authorized representatives of Infineon Technologies, Infineon Technologies' products may not be used in any applications where a failure of the product or any consequences of the use thereof can reasonably be expected to result in personal injury

Looking for pricing, stock, or lifecycle information?

Click below to explore more details on WIN SOURCE:

- ⊖ [View TLE493DA2B6HTSA1 on WIN SOURCE](#)
- ⊖ [Infineon Technologies Information](#)

Optimize Your Supply Chain with WIN SOURCE Solutions

- ✓ Global Sourcing Solution
- ✓ Obsolete Management
- ✓ Cost Control Management
- ✓ Shortage Management
- ✓ Alternative Solution
- ✓ Excess Inventory Management