



**THE DATASHEET OF  
BGSA400ML10E6327XTSA1**



# BGSA400ML10

## Ultra high RF voltage antenna tuning switch

### Features

- Low  $R_{ON}$  resistance of  $2.0 \Omega$  at each port in ON state
- Low  $C_{OFF}$  capacitance of 165 fF at each port in OFF state
- High RF operating peak voltage handling of typical 90 V in OFF state
- Low harmonic generation
- MIPI RFFE 2.1 control interface
- Extremely low current consumption of 22  $\mu$ A
- 4 default USID addresses via external USID\_SEL pin
- Small form factor 1.1 mm x 1.5 mm (MSL1, 260 °C per JEDEC J-STD-020)

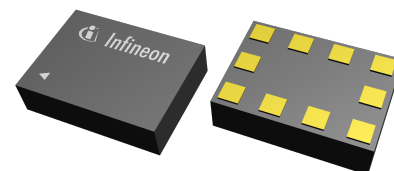

- RoHS
- Halogen-Free
- Lead-Free
- Green

### Potential applications

- Impedance, antenna and inductance tuning
- Tunable filters

### Product validation

Qualified for industrial applications according to the relevant tests of JEDEC47/20/22.

### Description

The BGSA400ML10 is a versatile shunt to ground 4xsingle-pole single-throw (4xSPST) RF antenna tuning switch. It is optimized for low  $C_{OFF}$  as well as low  $R_{ON}$  enabling applications up to 7.125 GHz.

The BGSA400ML10 is ideal for antenna tuning application. This chip integrates on-chip CMOS logic and power supply regulation. Its digital control interface is compliant with MIPI2.1 RFFE specification and each switch throw can be programmed individually or all together in the same RFFE command frame. Up to 4 instantiations of the same device can be controlled using the same RFFE bus thanks to its 4 states USID\_SEL pin unique feature.

### Block diagram

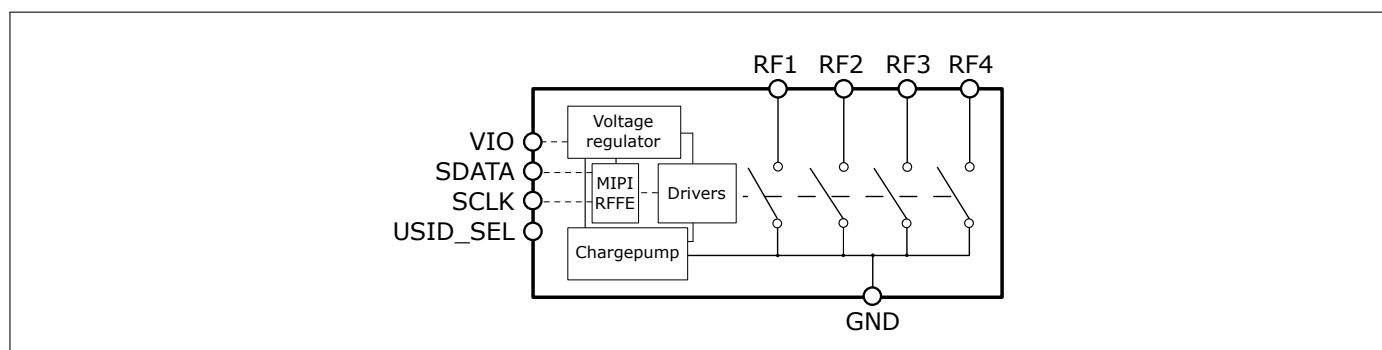

Type	Marking	Package	Ordering information
BGSA400ML10	4T	TSLP-10-3	BGSA 400ML10 E6327

# BGSA400ML10

## Ultra high RF voltage antenna tuning switch

---

### Table of contents

## Table of contents

<b>1</b>	<b>Maximum ratings</b>	<b>2</b>
<b>2</b>	<b>DC characteristics</b>	<b>4</b>
<b>3</b>	<b>RF small signal characteristics</b>	<b>5</b>
<b>4</b>	<b>RF large signal characteristics</b>	<b>7</b>
<b>5</b>	<b>MIPI RFFE specification</b>	<b>9</b>
<b>6</b>	<b>Application information</b>	<b>17</b>
<b>7</b>	<b>Package information</b>	<b>19</b>

# BGSA400ML10

## Ultra high RF voltage antenna tuning switch

### Maximum ratings

## 1 Maximum ratings

**Table 1: Maximum ratings table** at  $T_A = 25\text{ }^\circ\text{C}$ , unless otherwise specified

Parameter	Symbol	Values			Unit	Note / Test condition
		Min.	Typ.	Max.		
Frequency range	$f$	0.4	–	7.125	GHz	<sup>1)</sup>
RFFE supply voltage <sup>2)</sup>	$V_{IO}$	-0.3	–	2.2	V	Only for infrequent and short duration time periods
Storage temperature range	$T_{STG}$	-55	–	150	$^\circ\text{C}$	–
RF peak voltage	$V_{RF\_max}$	–	–	90	V	Short term peaks (1 $\mu\text{s}$ in 0.1% duty cycle), exceeding typical linearity, $R_{ON}$ and $C_{OFF}$ parameters, in isolation mode, test condition schematic in Fig. 1
ESD robustness, CDM <sup>3)</sup>	$V_{ESDCDM}$	-1	–	+1	kV	
ESD robustness, HBM <sup>4)</sup>	$V_{ESDHBM}$	-2	–	+2	kV	
Junction temperature	$T_j$	–	–	125	$^\circ\text{C}$	–
Thermal resistance junction - soldering point	$R_{thJS}$	–	–	50	K/W	–
Maximum DC-voltage on RF-Ports and RF-Ground	$V_{RFDC}$	0	–	0	V	No DC voltage allowed on RF-Ports
RFFE control voltage levels	$V_{SCLK}$ , $V_{SDATA}$ , $V_{USID\_SEL}$	-0.7	–	$V_{IO}+0.7$ (max. 2.2)	V	–

<sup>1)</sup> Switch has a low-pass response. For higher frequencies, losses have to be considered for their impact on thermal heating. The DC voltage at RF ports  $V_{RFDC}$  has to be 0V.

<sup>2)</sup> Note: Consider any ripple voltages on top of  $V_{IO}$ . A high RF ripple at the  $V_{IO}$  can exceed the maximum ratings by  $V_{IO} = V_{DC} + V_{Ripple}$ .

<sup>3)</sup> Field-Induced Charged-Device Model ANSI/ESDA/JEDEC JS-002. Simulates charging/discharging events that occur in production equipment and processes. Potential for CDM ESD events occurs whenever there is metal-to-metal contact in manufacturing.

<sup>4)</sup> Human Body Model ANSI/ESDA/JEDEC JS-001 (R=1.5 k $\Omega$ , C=100 pF).

**Warning: Stresses above the max. values listed here may cause permanent damage to the device. Maximum ratings are absolute ratings; exceeding only one of these values may cause irreversible damage to the integrated circuit. Exposure to conditions at or below absolute maximum rating but above the specified maximum operation conditions may affect device reliability and life time. Functionality of the device might not be given under these conditions.**

# BGSA400ML10

## Ultra high RF voltage antenna tuning switch

### Maximum ratings

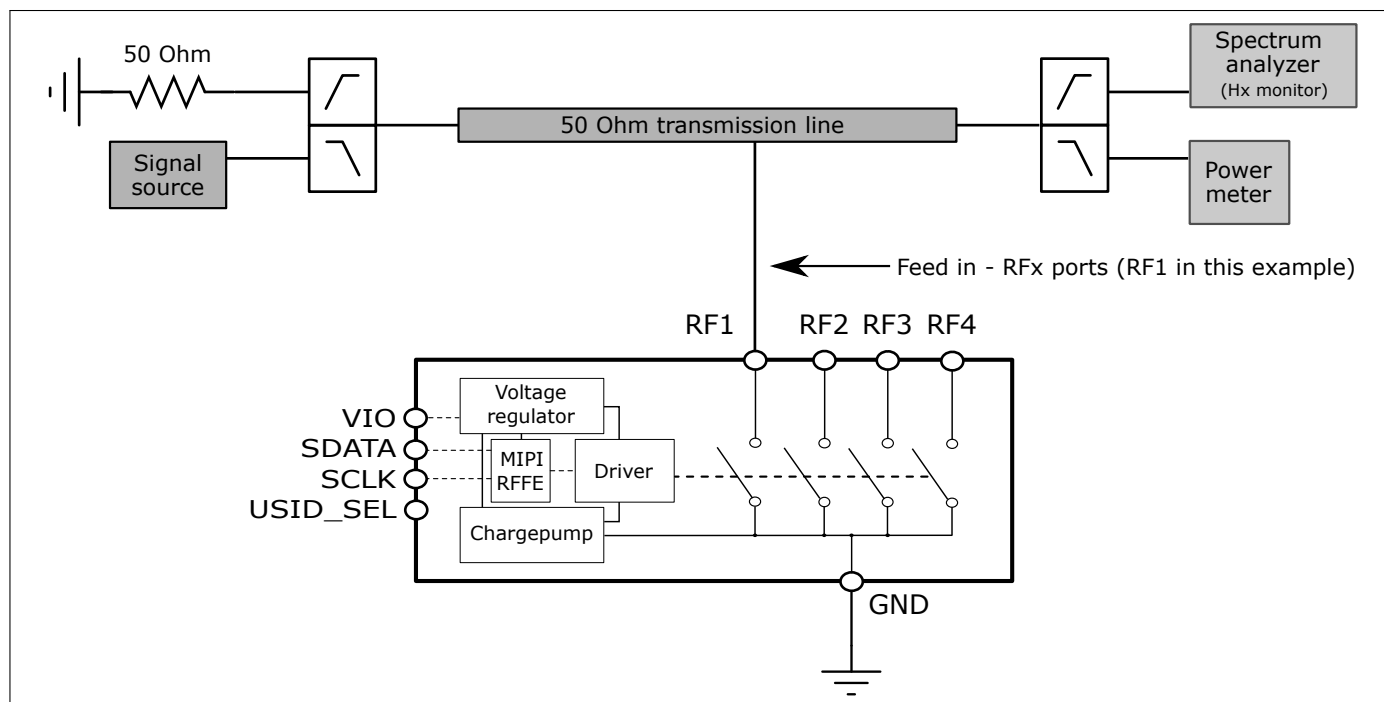

**Figure 1:** RF operating voltage and harmonic distortion measurement configuration

# BGSA400ML10

## Ultra high RF voltage antenna tuning switch

### DC characteristics

## 2 DC characteristics

**Table 2: DC characteristics** at  $T_A = -40\text{ °C}$  to  $85\text{ °C}$

Parameter	Symbol	Values			Unit	Note / Test condition
		Min.	Typ.	Max.		
RFFE supply voltage	$V_{IO}$	1.65	1.8	1.95	V	–
RFFE input high voltage <sup>1</sup>	$V_{IH}$	$0.7 \cdot V_{IO}$	–	$V_{IO}$	V	–
RFFE input low voltage <sup>1</sup>	$V_{IL}$	0	–	$0.3 \cdot V_{IO}$	V	–
RFFE output high voltage <sup>1</sup>	$V_{OH}$	$0.8 \cdot V_{IO}$	–	$V_{IO}$	V	–
RFFE output low voltage <sup>1</sup>	$V_{OL}$	0	–	$0.2 \cdot V_{IO}$	V	–
RFFE control input capacitance	$C_{Ctrl}$	–	–	2	pF	–
RFFE supply current <sup>2</sup>	$I_{VIO}$	–	22	40	$\mu\text{A}$	ACTIVE mode, $\leq 35\text{ dBm}$ RF power
		–	2	8	$\mu\text{A}$	SECONDARY_ACTIVE mode (LOW POWER) with analog circuitry powered OFF
		–	$0.5^3$	$1^3$	$\mu\text{A}$	

<sup>1</sup>SCLK and SDATA

<sup>2</sup>No traffic on MIPI bus

<sup>3</sup>Supply current reduced after first MIPI RFFE command

# BGSA400ML10

## Ultra high RF voltage antenna tuning switch

### RF small signal characteristics

### 3 RF small signal characteristics

**Table 3: Parametric specifications for each SPST**

Parameter	Symbol	Values			Unit	State / Notes
		Min.	Typ.	Max.		
RF1, RF2, RF3 or RF4 to GND DC ON resistance	$R_{ON_{SPST}}$	–	2.0	2.2	$\Omega$	$V_{IO} = 1.65 - 1.95 \text{ V}$ , $T_A = 25 \text{ }^\circ\text{C}$ , $Z_0 = 50 \Omega$
RF1, RF2, RF3 or RF4 to GND OFF capacitance, 1 GHz	$C_{OFF_{SPST}}$	–	165	180	fF	
RF1, RF2, RF3 or RF4 to GND DC OFF resistance	$R_{OFF_{SPST}}$	170	260	–	k $\Omega$	

# BGSA400ML10

## Ultra high RF voltage antenna tuning switch

### RF small signal characteristics

**Table 4: RF electrical parameters**

**Isolation between adjacent RF ports (All OFF / Isolation mode) <sup>1)</sup>**

Frequency range	Symbol	Values			Unit	State / Notes
		Min.	Typ.	Max.		
600 - 960 MHz	ISO	30	37	–	dB	State 0, $V_{IO} = 1.65 - 1.95 \text{ V}$ , $Z_0 = 50 \Omega$ , $T_A = -40 \text{ }^\circ\text{C} \dots + 85 \text{ }^\circ\text{C}$
1160 - 1300 MHz		28	33	–	dB	
1400 - 1700 MHz		26	31	–	dB	
1700 - 2200 MHz		23	29	–	dB	
2200 - 2700 MHz		21	27	–	dB	
3300 - 4200 MHz		19	24	–	dB	
4400 - 5000 MHz		17	23	–	dB	
5150 - 5925 MHz		15	22	–	dB	
5950 - 7125 MHz		15	22	–	dB	

**Isolation between non-adjacent RF ports (All OFF / Isolation mode) <sup>1)</sup>**

600 - 960 MHz	ISO	50	60	–	dB	State 0, $V_{IO} = 1.65 - 1.95 \text{ V}$ , $Z_0 = 50 \Omega$ , $T_A = -40 \text{ }^\circ\text{C} \dots + 85 \text{ }^\circ\text{C}$
1160 - 1300 MHz		47	56	–	dB	
1400 - 1700 MHz		46	55	–	dB	
1700 - 2200 MHz		45	53	–	dB	
2200 - 2700 MHz		43	51	–	dB	
3300 - 4200 MHz		40	48	–	dB	
4400 - 5000 MHz		35	48	–	dB	
5150 - 5925 MHz		35	47	–	dB	
5950 - 7125 MHz		35	49	–	dB	

**Isolation between adjacent RF ports (RFx ON mode) <sup>1)</sup>**

600 - 960 MHz	ISO	30	47	–	dB	State 1, 2, 4, 8, $V_{IO} = 1.65 - 1.95 \text{ V}$ , $Z_0 = 50 \Omega$ , $T_A = -40 \text{ }^\circ\text{C} \dots + 85 \text{ }^\circ\text{C}$
1160 - 1300 MHz		28	42	–	dB	
1400 - 1700 MHz		25	39	–	dB	
1700 - 2200 MHz		23	36	–	dB	
2200 - 2700 MHz		21	33	–	dB	
3300 - 4200 MHz		19	28	–	dB	
4400 - 5000 MHz		17	26	–	dB	
5150 - 5925 MHz		15	24	–	dB	
5950 - 7125 MHz		15	22	–	dB	

**Isolation between non-adjacent RF ports (RFx ON mode) <sup>1)</sup>**

600 - 960 MHz	ISO	50	67	–	dB	State 1, 2, 4, 8, $V_{IO} = 1.65 - 1.95 \text{ V}$ , $Z_0 = 50 \Omega$ , $T_A = -40 \text{ }^\circ\text{C} \dots + 85 \text{ }^\circ\text{C}$
1160 - 1300 MHz		48	61	–	dB	
1400 - 1700 MHz		46	58	–	dB	
1700 - 2200 MHz		45	56	–	dB	
2200 - 2700 MHz		43	53	–	dB	
3300 - 4200 MHz		35	49	–	dB	
4400 - 5000 MHz		33	47	–	dB	
5150 - 5925 MHz		30	45	–	dB	
5950 - 7125 MHz		28	43	–	dB	

<sup>1)</sup> On application board without any matching components

## 4 RF large signal characteristics

**Table 5: RF large signal specifications** at  $T_A = -40\text{ °C} \dots +85\text{ °C}$ , unless otherwise specified

Parameter	Symbol	Values			Unit	Note / Test condition
		Min.	Typ.	Max.		
RF operating voltage	$V_{RF\_opr}$	-	-	85	V	In isolation mode, 900MHz, Test condition schematic in Fig. 1, $T_A = 25\text{ °C}$
<b>Harmonic distortion, off mode</b>						
All RF ports Second order harmonics	$P_{H2}$	-	-95	-85	dBm	26 dBm, 50 $\Omega$ , $f_0 = 663\text{ MHz}$
All RF ports Third order harmonics	$P_{H3}$	-	-100	-90	dBm	26 dBm, 50 $\Omega$ , $f_0 = 663\text{ MHz}$
All RF ports Second order harmonics	$P_{H2}$	-	-75	-65	dBm	35 dBm, 50 $\Omega$ , $f_0 = 920\text{ MHz}$
All RF ports Third order harmonics	$P_{H3}$	-	-82	-72	dBm	35 dBm, 50 $\Omega$ , $f_0 = 920\text{ MHz}$
All RF ports Second order harmonics	$P_{H2}$	-	-75	-65	dBm	33 dBm, 50 $\Omega$ , $f_0 = 1910\text{ MHz}$
All RF ports Third order harmonics	$P_{H3}$	-	-83	-73	dBm	33 dBm, 50 $\Omega$ , $f_0 = 1910\text{ MHz}$
All RF ports Second order harmonics	$P_{H2}$	-	-82	-72	dBm	29 dBm, 50 $\Omega$ , $f_0 = 2690\text{ MHz}$
All RF ports Third order harmonics	$P_{H3}$	-	-88	-78	dBm	29 dBm, 50 $\Omega$ , $f_0 = 2690\text{ MHz}$
All RF ports Second order harmonics	$P_{H2}$	-	-77	-67	dBm	29 dBm, 50 $\Omega$ , $f_0 = 3600\text{ MHz}$
All RF ports Third order harmonics	$P_{H3}$	-	-90	-80	dBm	29 dBm, 50 $\Omega$ , $f_0 = 3600\text{ MHz}$
All RF ports Second order harmonics	$P_{H2}$	-	-75	-65	dBm	29 dBm, 50 $\Omega$ , $f_0 = 4400\text{ MHz}$
All RF ports Third order harmonics	$P_{H3}$	-	-85	-75	dBm	29 dBm, 50 $\Omega$ , $f_0 = 4400\text{ MHz}$
All RF ports Second order harmonics	$P_{H2}$	-	-75	-65	dBm	29 dBm, 50 $\Omega$ , $f_0 = 5000\text{ MHz}$
All RF ports Third order harmonics	$P_{H3}$	-	-85	-75	dBm	29 dBm, 50 $\Omega$ , $f_0 = 5000\text{ MHz}$
All RF ports > Third order harmonics	$P_{Hx}$	-	-	-80	dBm	29 dBm, 50 $\Omega$

# BGSA400ML10

## Ultra high RF voltage antenna tuning switch

### RF large signal characteristics

**Table 6: RF large signal specifications** at  $T_A = -40\text{ }^{\circ}\text{C} \dots +85\text{ }^{\circ}\text{C}$ , unless otherwise specified

Parameter	Symbol	Values			Unit	Note / Test condition
		Min.	Typ.	Max.		
<b>Intermodulation distortion IIP2</b>						
IIP2, low	IIP2,l	120	135	–	dBm	IIP2 conditions in Tab. 7
IIP2, high	IIP2,h	125	135	–	dBm	
<b>Intermodulation distortion IIP3</b>						
IIP3	IIP3	74	82	–	dBm	IIP3 conditions in Tab. 8

**Table 7: IIP2 conditions table**

Band	In-band frequency [MHz]	Blocker frequency 1 [MHz]	Blocker power 1 [dBm]	Blocker frequency 2 [MHz]	Blocker power 2 [dBm]
Band 1 low	2140	1950	20	190	0
Band 1 high	2140	1950	20	4090	0
Band 5 low	881.5	836.5	20	45	0
Band 5 high	881.5	836.5	20	1718	0
Band 7 low	2655	2535	20	120	0
Band 7 high	2655	2535	20	5910	0

**Table 8: IIP3 conditions table**

Band	In-band frequency [MHz]	Blocker frequency 1 [MHz]	Blocker power 1 [dBm]	Blocker frequency 2 [MHz]	Blocker power 2 [dBm]
Band 1	2140	1950	20	1760	0
Band 5	881.5	836.5	20	791.5	0
Band 7	2655	2535	20	2415	0

# BGSA400ML10

## Ultra high RF voltage antenna tuning switch

### MIPI RFFE specification

## 5 MIPI RFFE specification

The MIPI RFFE interface is implemented according to the following specifications and documents:

- MIPI Alliance Specification for RF Front-End Control Interface Version 2.1 - 18 December 2017
- MIPI Alliance Errata 01 for MIPI RFFE Specification Version v2.1 - 24 February 2019
- Qualcomm RFFE Vendor Specification 80-N7876-1 Rev. Y (December 3, 2018)

**Table 9: MIPI features**

Feature	Supported	Comment
MIPI RFFE 2.1 standard	Yes	Backward compatible to MIPI 2.0 standard
Register 0 write command sequence	Yes	
Register read and write command sequence	Yes	
Extended register read and write command sequence	Yes	
Masked write command sequence	Yes	Indicated as MW in below register mapping tables
Support for standard frequency range operations for SCLK	Yes	Up to 26 MHz
Support for extended frequency range operations for SCLK	Yes	Up to 52 MHz
Longer reach RFFE bus length feature	Yes	
Programmable driver strength	Yes	Up to 80 pF
Programmable Group SID	Yes	
Programmable USID	Yes	
Trigger functionality	Yes	
Extended triggers and trigger masks	Yes	
Broadcast / GSID write to PM TRIG register	Yes	
Reset	Yes	Via VIO, PM TRIG or software register
Status / error sum register	Yes	
Extended product ID register	Yes	
Revision ID register	Yes	
Group SID register	Yes	
USID select pin	Yes	See Tab. 16

**Table 10: Startup behavior**

Feature	State	Comment
Power status	Low power	Device in SECONDARY_ACTIVE mode (LOW POWER) after start-up
Trigger function	Enabled	Enabled after start-up. Programmable via behavior control register

# BGSA400ML10

## Ultra high RF voltage antenna tuning switch

### MIPI RFFE specification

**Table 11: Device control timing** at  $V_{IO} = 1.65 - 1.95\text{ V}$ ,  $T_A = 25\text{ }^\circ\text{C}$ ,  $P_{IN} = 0\text{ dBm}$

Parameter	Symbol	Values			Unit	State / Notes
		Min.	Typ.	Max.		
ON switching time	$t_{ST,ON}$	-	-	20	$\mu\text{s}$	50% last SCLK rising edge of the register write command to 10% of RF amplitude, see Fig. 2
OFF switching time	$t_{ST,OFF}$	-	-	5	$\mu\text{s}$	50% last SCLK rising edge of the register write command to 90% of RF amplitude, see Fig. 2

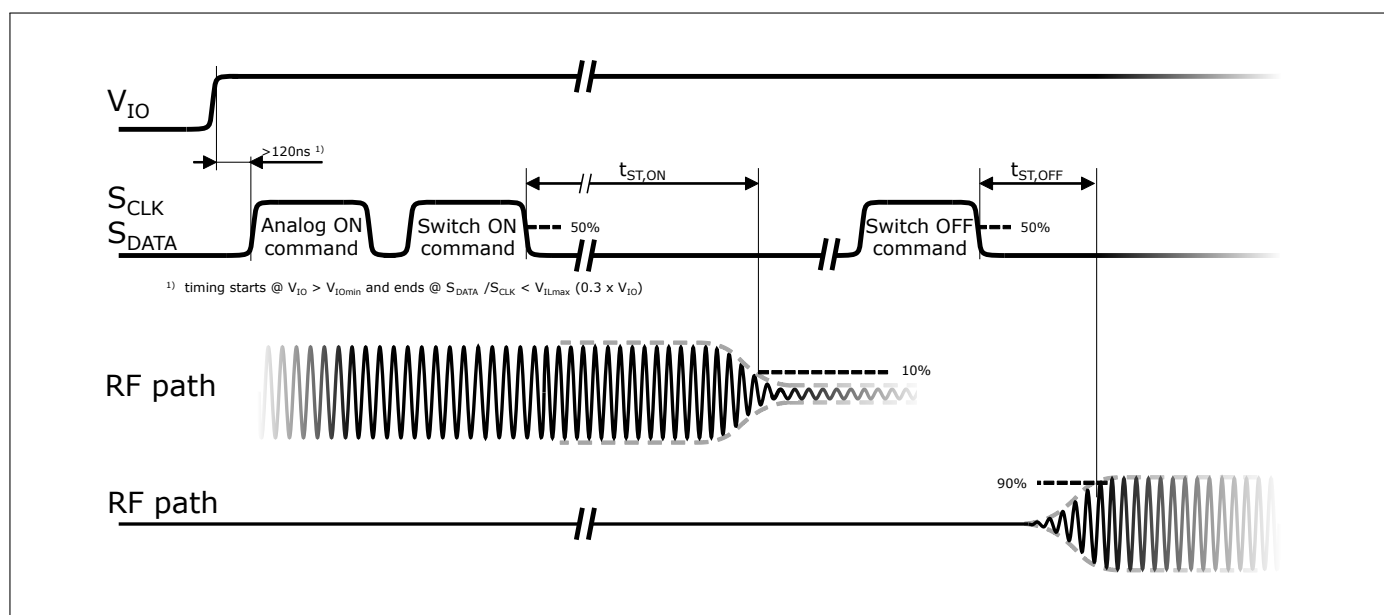

**Figure 2:** BGSA400ML10 switching time behavior

# BGSA400ML10

## Ultra high RF voltage antenna tuning switch



### MIPI RFFE specification

**Table 12: Register mapping, table I**

Register address	Register name	Data bits	Function	Description	Default	Broadcast_ID support	Trigger support	R/W	
0x00	REGISTER_0	7:0	MODE_CTRL	RF switch control	00000000	No	Yes Trigger 0-10	R/W MW	
0x01	REGISTER_1	7:0	MODE_CTRL	RF Switch Control	00000000	No	Yes Trigger 0-10	R/W MW	
0x1C	PM_TRIG	7	PWR_MODE(1) Operation mode	0: Normal operation (ACTIVE)	1	Yes	No	R/W MW	
				1: Low power mode (SECONDARY_ACTIVE)					
		6	PWR_MODE(0) State bit vector	0: No action (ACTIVE)	0				
				1: Powered reset (ACTIVE to STARTUP)					
		5	TRIGGER_MASK_2	0: Data masked (held in shadow REG)	0				No
				1: Data not masked (ready for transfer to active REG)					
		4	TRIGGER_MASK_1	0: Data masked (held in shadow REG)	0				
				1: Data not masked (ready for transfer to active REG)					
		3	TRIGGER_MASK_0	0: Data masked (held in shadow REG)	0				
				1: Data not masked (ready for transfer to active REG)					
2	TRIGGER_2	0: No action (data held in shadow REG)	0	Yes					
		1: Data transferred to active REG							
1	TRIGGER_1	0: No action (data held in shadow REG)	0						
		1: Data transferred to active REG							
0	TRIGGER_0	0: No action (data held in shadow REG)	0						
		1: Data transferred to active REG							
0x1D	PRODUCT_ID	7:0	PRODUCT_ID	This is a read-only register. However, during the programming of the USID a write command sequence is performed on this register, even though the write does not change its value.	11111100	No	No	R	
0x1E	MAN_ID	7:0	MANUFACTURER_ID [7:0]	This is a read-only register. However, during the programming of the USID, a write command sequence is performed on this register, even though the write does not change its value.	00011010	No	No	R	
0x1F	MAN_USID	7:4	MANUFACTURER_ID [11:8]	These bits are read-only. However, during the programming of the USID, a write command sequence is performed on this register even though the write does not change its value.	0001				
		3:0	USID[3:0]	USID_Sel pin	See Tab. 16	No	No	R/W	

# BGSA400ML10

## Ultra high RF voltage antenna tuning switch



### MIPI RFFE specification

**Table 13: Register mapping, table II**

Register address	Register name	Data bits	Function	Description	Default	Broadcast_ID support	Trigger support	R/W
0x20	EXT_PRODUCT_ID	7:0	EXT_PRODUCT_ID	Extension to PRODUCT_ID in register 0x1D. This is a read-only register. However, during the programming of the USID a write command sequence is performed on this register, even though the write does not change its value.	00000000	No	No	R
0x21	REV_ID	7:4	MAIN_REVISION	Chip main revision	0000	No	No	R
		3:0	SUB_REVISION	Chip sub revision	0000			
0x22	GSID	7:4	GSID0[3:0]	Primary group slave ID.	0000	No	No	R/W
		3:0	GSID1[3:0]	Secondary group slave ID.	0000			
0x23	UDR_RST	7	UDR_RST	Reset all configurable non-RFFE Reserved registers to default values. 0: Normal operation 1: Software reset	0	Yes	No	R/W
		6:0	RESERVED	Reserved for future use	00000000			
0x24	ERR_SUM	7	RESERVED	Reserved for future use	0	No	No	R
		6	COMMAND_FRAME_PARITY_ERR	Command sSequence received with parity error – discard command.	0			
		5	COMMAND_LENGTH_ERR	Command length error.	0			
		4	ADDRESS_FRAME_PARITY_ERR	Address frame with parity error.	0			
		3	DATA_FRAME_PARITY_ERR	Data frame with parity error.	0			
		2	READ_UNUSED_REG	Read command to an invalid address.	0			
		1	WRITE_UNUSED_REG	Write command to an invalid address.	0			
		0	BID_GID_ERR	Read command with a BROADCAST_ID or GROUP_ID.	0			
0x2B	BUS_LD	7:3	RESERVED	Reserved for future use	0x0	No	No	R/W
		2:0	BUS_LD[2:0]	Program the drive strength of the SDATA driver in readback modes.  0x0: 10 pF 0x1: 20 pF 0x2: 30 pF 0x3: 40 pF 0x4: 50 pF 0x5: 60 pF 0x6: 80 pF 0x7: 80 pF 0x8-0xF: reserved	0x4			

# BGSA400ML10

## Ultra high RF voltage antenna tuning switch



### MIPI RFFE specification

**Table 14: Register mapping, table III**

Register address	Register name	Data bits	Function	Description	Default	Broadcast_ID support	Trigger support	R/W	
0x2D	EXT_TRIG_MASK	7	TRIGGER_MASK_10	0: Data writes to registers tied to EXT_TRIGGER_10 are masked. Data is held in shadow registers until the EXT_TRIGGER_10 bit is set to 1.	1	No	No	R/W	
				1: Data writes to registers tied to EXT_TRIGGER_10 are not masked. Data writes go directly to the active registers.					
		6	TRIGGER_MASK_9	0: Data writes to registers tied to EXT_TRIGGER_9 are masked. Data is held in shadow registers until the EXT_TRIGGER_9 bit is set to 1.	1				MW
				1: Data writes to registers tied to EXT_TRIGGER_9 are not masked. Data writes go directly to the active registers.					
		5	TRIGGER_MASK_8	0: Data writes to registers tied to EXT_TRIGGER_8 are masked. Data is held in shadow registers until the EXT_TRIGGER_8 bit is set to 1.	1				
				1: Data writes to registers tied to EXT_TRIGGER_8 are not masked. Data writes go directly to the active registers.					
		4	TRIGGER_MASK_7	0: Data writes to registers tied to EXT_TRIGGER_7 are masked. Data is held in shadow registers until the EXT_TRIGGER_7 bit is set to 1.	1				
				1: Data writes to registers tied to EXT_TRIGGER_7 are not masked. Data writes go directly to the active registers.					
		3	TRIGGER_MASK_6	0: Data writes to registers tied to EXT_TRIGGER_6 are masked. Data is held in shadow registers until the EXT_TRIGGER_6 bit is set to 1.	1				
				1: Data writes to registers tied to EXT_TRIGGER_6 are not masked. Data writes go directly to the active registers.					
		2	TRIGGER_MASK_5	0: Data writes to registers tied to EXT_TRIGGER_5 are masked. Data is held in shadow registers until the EXT_TRIGGER_5 bit is set to 1.	1				
				1: Data writes to registers tied to EXT_TRIGGER_5 are not masked. Data writes go directly to the active registers.					
		1	TRIGGER_MASK_4	0: Data writes to registers tied to EXT_TRIGGER_4 are masked. Data is held in shadow registers until the EXT_TRIGGER_4 bit is set to 1.	1				
				1: Data writes to registers tied to EXT_TRIGGER_4 are not masked. Data writes go directly to the active registers.					
0	TRIGGER_MASK_3	0: Data writes to registers tied to EXT_TRIGGER_3 are masked. Data is held in shadow registers until the EXT_TRIGGER_3 bit is set to 1.	1						
		1: Data writes to registers tied to EXT_TRIGGER_3 are not masked. Data writes go directly to the active registers.							

# BGSA400ML10

## Ultra high RF voltage antenna tuning switch



### MIPI RFFE specification

**Table 15: Register mapping, table IV**

Register address	Register name	Data bits	Function	Description	Default	Broadcast_ID support	Trigger support	R/W
0x2E	EXT_TRIG	7	TRIGGER_10	0: No action. Data is held in shadow registers.	0	Yes	No	R/W
				1: Data is transferred from shadow registers to active registers for registers tied to EXT_TRIGGER_10				
		6	TRIGGER_9	0: No action. Data is held in shadow registers.	0			
				1: Data is transferred from shadow registers to active registers for registers tied to EXT_TRIGGER_9				
		5	TRIGGER_8	0: No action. Data is held in shadow registers.	0			
				1: Data is transferred from shadow registers to active registers for registers tied to EXT_TRIGGER_8				
		4	TRIGGER_7	0: No action. Data is held in shadow registers.	0			
				1: Data is transferred from shadow registers to active registers for registers tied to EXT_TRIGGER_7				
		3	TRIGGER_6	0: No action. Data is held in shadow registers.	0			
				1: Data is transferred from shadow registers to active registers for registers tied to EXT_TRIGGER_6				
		2	TRIGGER_5	0: No action. Data is held in shadow registers.	0			
				1: Data is transferred from shadow registers to active registers for registers tied to EXT_TRIGGER_5				
		1	TRIGGER_4	0: No action. Data is held in shadow registers.	0			
				1: Data is transferred from shadow registers to active registers for registers tied to EXT_TRIGGER_4				
		0	TRIGGER_3	0: No action. Data is held in shadow registers.	0			
				1: Data is transferred from shadow registers to active registers for registers tied to EXT_TRIGGER_3				

# BGSA400ML10

## Ultra high RF voltage antenna tuning switch

### MIPI RFFE specification

**Table 16: Default MIPI USID selection**

Address	Symbol	External conditon at USID_SEL Pin
USID=0110	Addr6	Ground
USID=0111	Addr7	to VIO
USID=1000	Addr8	Floating <sup>1)</sup>
USID=1001	Addr9	220 kΩ to VIO <sup>1)</sup>

<sup>1)</sup> Total capacitance on the USID\_SEL pin must be <5 pF.

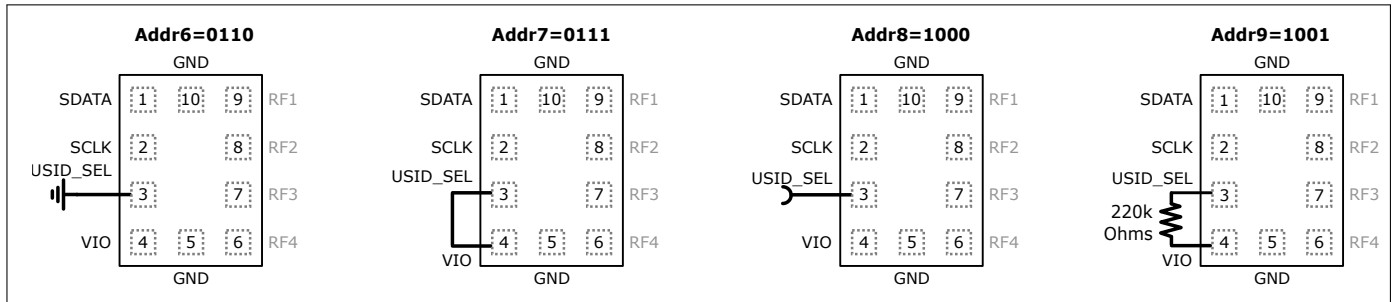

**Figure 3:** BGSA400ML10 USID\_Sel pin configuration

# BGSA400ML10

## Ultra high RF voltage antenna tuning switch



### MIPI RFFE specification

**Warning: Register\_0 and Register\_1 RF switch control bits are identical. Writing both registers Register\_0 and Register\_1 simultaneously will lead to undefined behavior. The unused register (Register\_0 or Register\_1) must remain 0x00.**

**Table 17: Modes of operation (Truth table, Register\_0)**

State	Mode	D7	D6	D5	D4	D3	D2	D1	D0
0	ALL OFF (Isolation)	x	x	x	x	0	0	0	0
1	RF1 ON	x	x	x	x	0	0	0	1
2	RF2 ON	x	x	x	x	0	0	1	0
3	RF1+RF2 ON	x	x	x	x	0	0	1	1
4	RF3 ON	x	x	x	x	0	1	0	0
5	RF1+RF3 ON	x	x	x	x	0	1	0	1
6	RF2+RF3 ON	x	x	x	x	0	1	1	0
7	RF1+RF2+RF3 ON	x	x	x	x	0	1	1	1
8	RF4 ON	x	x	x	x	1	0	0	0
9	RF1+RF4 ON	x	x	x	x	1	0	0	1
10	RF2+RF4 ON	x	x	x	x	1	0	1	0
11	RF1+RF2+RF4 ON	x	x	x	x	1	0	1	1
12	RF3+RF4 ON	x	x	x	x	1	1	0	0
13	RF1+RF3+RF4 ON	x	x	x	x	1	1	0	1
14	RF2+RF3+RF4 ON	x	x	x	x	1	1	1	0
15	RF1+RF2+RF3+RF4 ON	x	x	x	x	1	1	1	1

<sup>1)</sup>Do not care, x = 0 or 1

**Table 18: Modes of operation (Truth table, Register\_1)**

State	Mode	D7	D6	D5	D4	D3	D2	D1	D0
0	ALL OFF (Isolation)	x	x	x	x	0	0	0	0
1	RF1 ON	x	x	x	x	0	0	0	1
2	RF2 ON	x	x	x	x	0	0	1	0
3	RF1+RF2 ON	x	x	x	x	0	0	1	1
4	RF3 ON	x	x	x	x	0	1	0	0
5	RF1+RF3 ON	x	x	x	x	0	1	0	1
6	RF2+RF3 ON	x	x	x	x	0	1	1	0
7	RF1+RF2+RF3 ON	x	x	x	x	0	1	1	1
8	RF4 ON	x	x	x	x	1	0	0	0
9	RF1+RF4 ON	x	x	x	x	1	0	0	1
10	RF2+RF4 ON	x	x	x	x	1	0	1	0
11	RF1+RF2+RF4 ON	x	x	x	x	1	0	1	1
12	RF3+RF4 ON	x	x	x	x	1	1	0	0
13	RF1+RF3+RF4 ON	x	x	x	x	1	1	0	1
14	RF2+RF3+RF4 ON	x	x	x	x	1	1	1	0
15	RF1+RF2+RF3+RF4 ON	x	x	x	x	1	1	1	1

<sup>1)</sup>Do not care, x = 0 or 1

# BGSA400ML10

## Ultra high RF voltage antenna tuning switch

### Application information

## 6 Application information

### Pin configuration and function

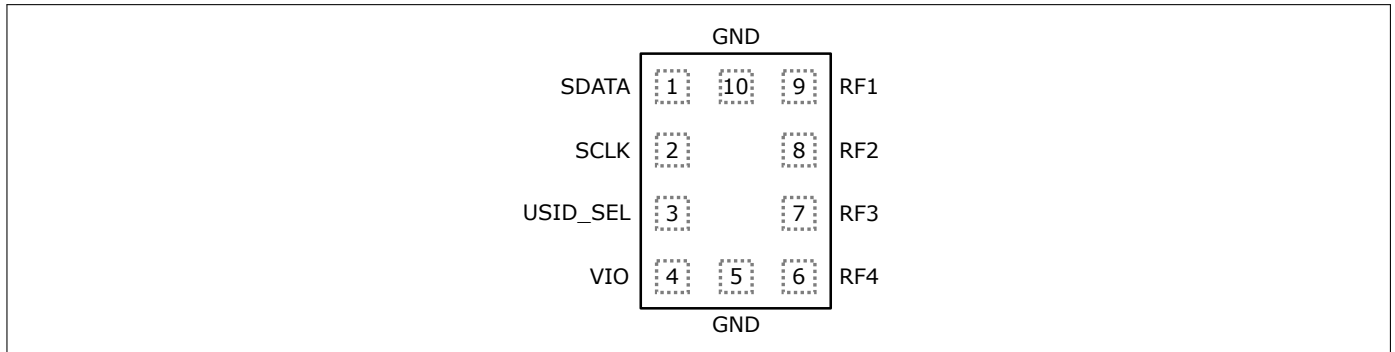

**Figure 4:** BGSA400ML10 pin configuration (top view)

**Table 19: Pin definition and function**

Pin No.	Name	Function
1	SDATA	MIPI RFFE data input / output
2	SCLK	MIPI RFFE clock input
3	USID_SEL	USID default address selection pin (see Tab. 16)
4	VIO	Voltage supply compatible with MIPI RFFE specification
5	GND	Ground
6	RF4	RF4 port
7	RF3	RF3 port
8	RF2	RF2 port
9	RF1	RF1 port
10	GND	Ground

# BGSA400ML10

## Ultra high RF voltage antenna tuning switch

### Application information

### Evaluation board description

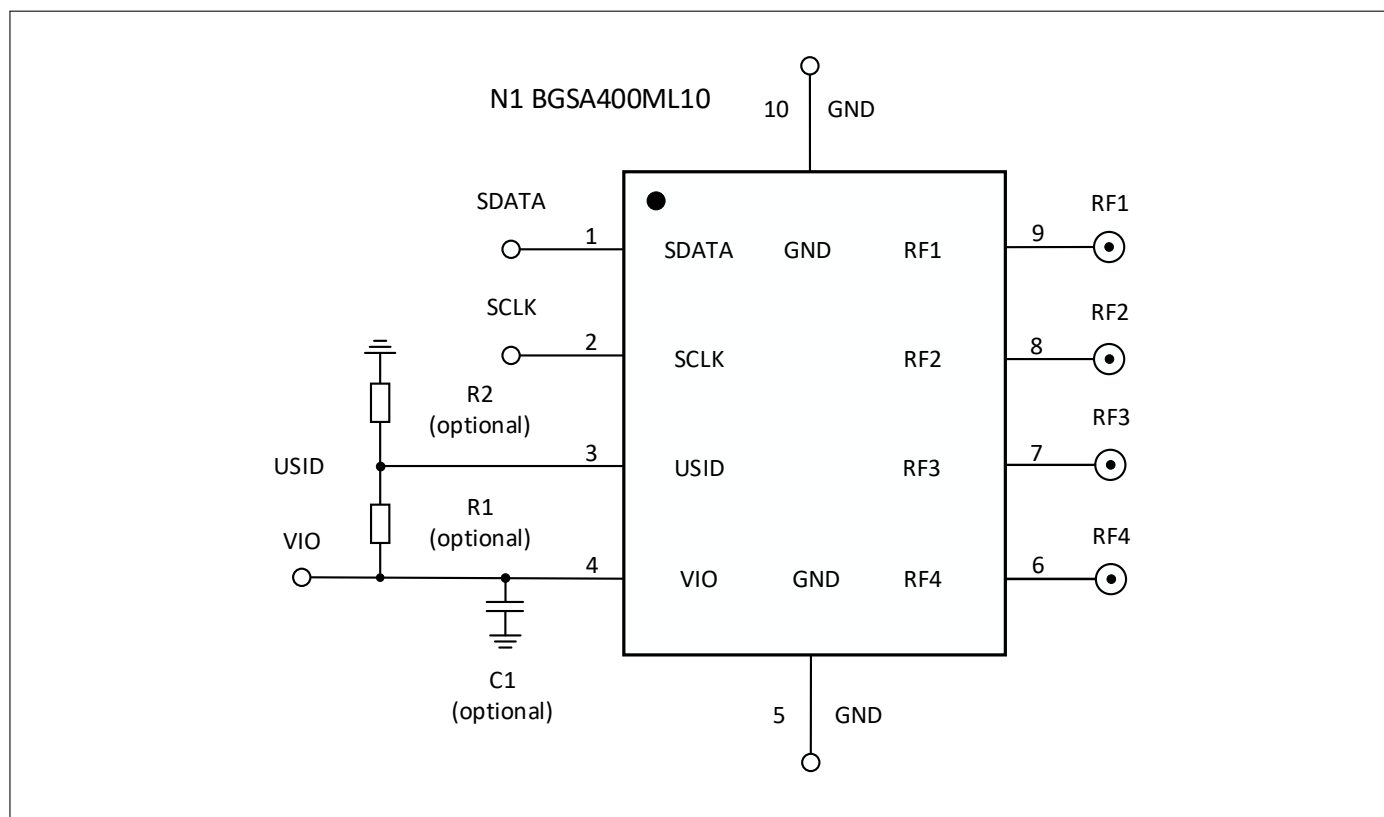

**Figure 5:** BGSA400ML10 application schematic

**Table 20: Bill of materials**

Name	Part type	Package	Manufacturer	Function
C1 (1nF optional) <sup>1)</sup>	Capacitor	0402	Various	De-coupling capacitor
N1	BGSA400ML10	TSLP-10-3	Infineon	Antenna tuner
R1 (do not place) R2 (0 Ohm)	Resistor	0402	Various	Set USID default address to 6 (GND)
R1 (0 Ohm) R2 (do not place)	Resistor	0402	Various	Set USID default address to 7 (VIO)
R1 (do not place) R2 (do not place)	Resistor	0402	Various	Set USID default address to 8 (FLOATING)
R1 (220 kOhm) R2 (do not place)	Resistor	0402	Various	Set USID default address to 9 (220 kOhm to VIO)

<sup>1)</sup> This capacitor is optional and value is only indicative. Decoupling capacitor value has to be chosen in order VIO ramp-up time is within MIPI RFFE version v2.1 specification.

# BGSA400ML10

## Ultra high RF voltage antenna tuning switch

### Package information

## 7 Package information

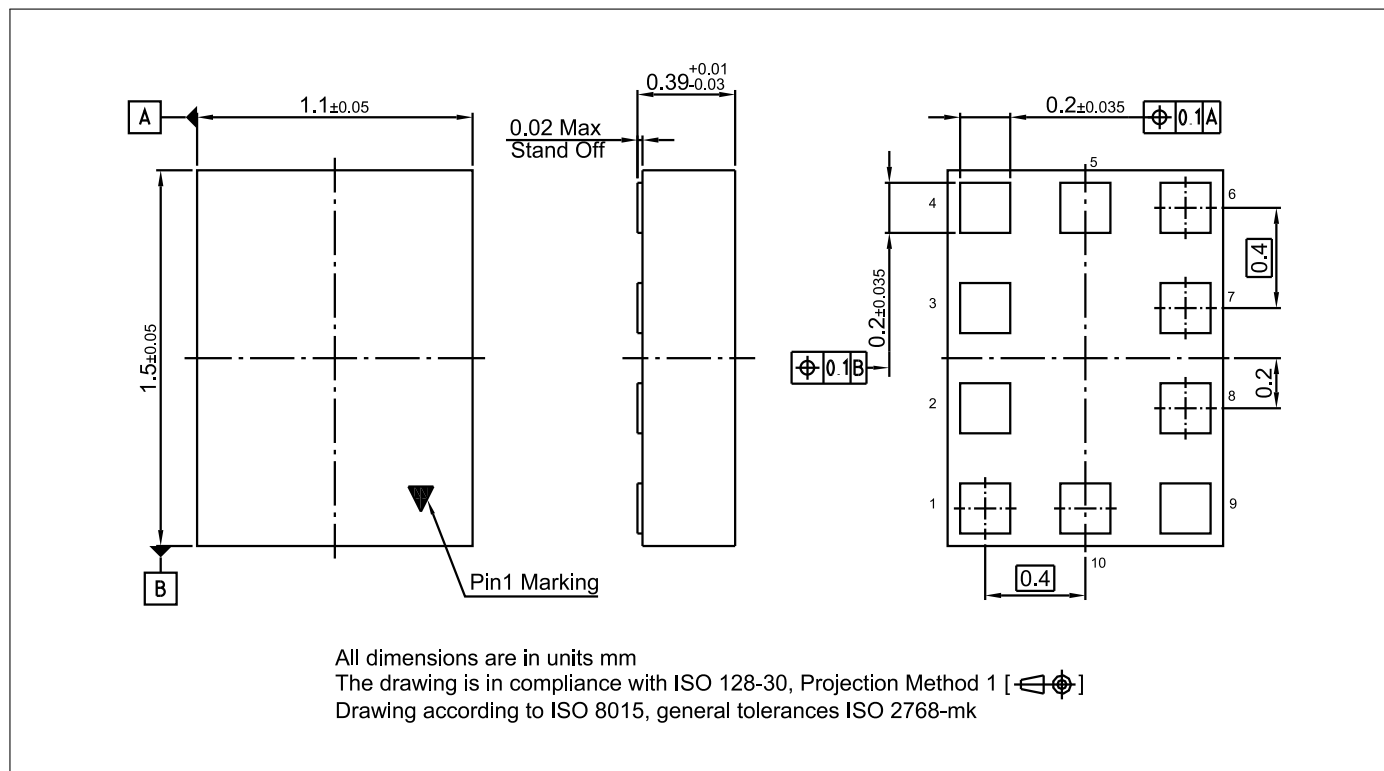

**Figure 6:** TSLP-10-3 package outline (top, side and bottom views)

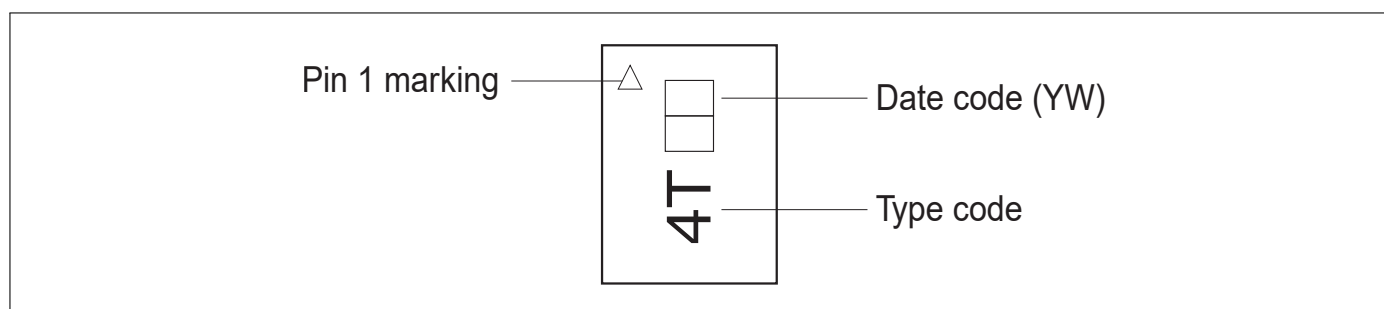

**Figure 7:** TSLP-10-3 marking specification (top view): date code digits Y and W defined in Tab. 21/22

**Table 21: Year date code marking - digit "Y"**

Year	"Y"	Year	"Y"	Year	"Y"
2010	0	2020	0	2030	0
2011	1	2021	1	2031	1
2012	2	2022	2	2032	2
2013	3	2023	3	2033	3
2014	4	2024	4	2034	4
2015	5	2025	5	2035	5
2016	6	2026	6	2036	6
2017	7	2027	7	2037	7
2018	8	2028	8	2038	8
2019	9	2029	9	2039	9

**Table 22: Week date code marking - digit "W"**

Week	"W"	Week	"W"	Week	"W"	Week	"W"	Week	"W"
1	A	12	N	23	4	34	h	45	v
2	B	13	P	24	5	35	j	46	x
3	C	14	Q	25	6	36	k	47	y
4	D	15	R	26	7	37	l	48	z
5	E	16	S	27	a	38	n	49	8
6	F	17	T	28	b	39	p	50	9
7	G	18	U	29	c	40	q	51	2
8	H	19	V	30	d	41	r	52	3
9	J	20	W	31	e	42	s	53	M
10	K	21	Y	32	f	43	t		
11	L	22	Z	33	g	44	u		



# BGSA400ML10

## Ultra high RF voltage antenna tuning switch

### Package information

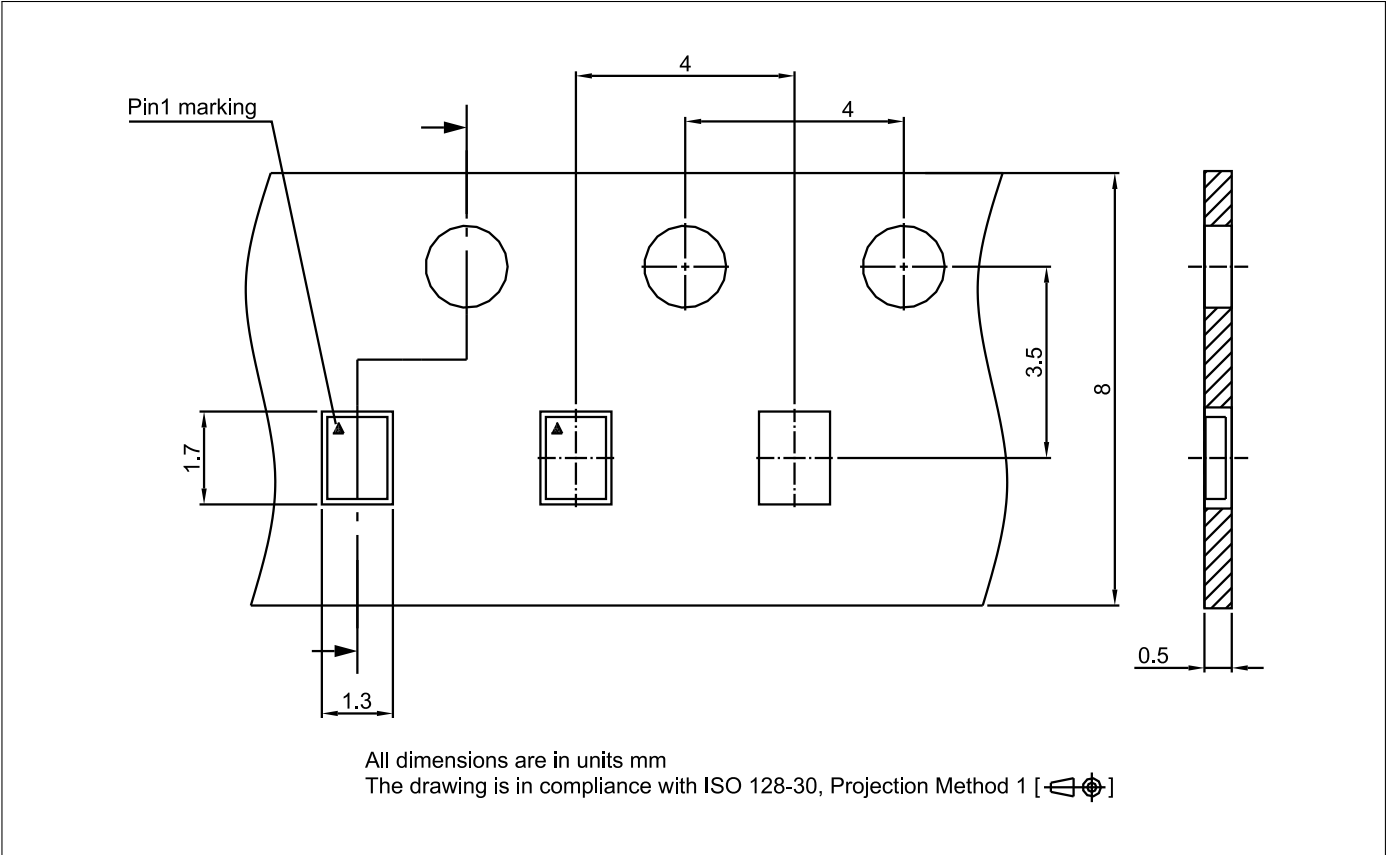

Figure 9: TSLP-10-3 carrier tape

---

**Revision history**

Page or item	Subjects (major changes since previous revision)
<b>Revision 2.1, 2022-01-31</b>	
Title page	Package drawing added
7	Note / Test condition for parameter "RF operating voltage" updated

**Trademarks**

All referenced product or service names and trademarks are the property of their respective owners.

**Edition 2024-04-24**

**Published by**

**Infineon Technologies AG**

**81726 Munich, Germany**

**© 2024 Infineon Technologies AG.**

**All Rights Reserved.**

**Do you have a question about any aspect of this document?**

**Email: [erratum@infineon.com](mailto:erratum@infineon.com)**

**IMPORTANT NOTICE**

The information given in this document shall in no event be regarded as a guarantee of conditions or characteristics ("Beschaffheitsgarantie"). With respect to any examples, hints or any typical values stated herein and/or any information regarding the application of the product, Infineon Technologies hereby disclaims any and all warranties and liabilities of any kind, including without limitation warranties of non-infringement of intellectual property rights of any third party. In addition, any information given in this document is subject to customer's compliance with its obligations stated in this document and any applicable legal requirements, norms and standards concerning customer's products and any use of the product of Infineon Technologies in customer's applications. The data contained in this document is exclusively intended for technically trained staff. It is the responsibility of customer's technical departments to evaluate the suitability of the product for the intended application and the completeness of the product information given in this document with respect to such application.

For further information on technology, delivery terms and conditions and prices, please contact the nearest Infineon Technologies Office ([www.infineon.com](http://www.infineon.com)).

**WARNINGS**

Due to technical requirements products may contain dangerous substances. For information on the types in question please contact your nearest Infineon Technologies office.

Except as otherwise explicitly approved by Infineon Technologies in a written document signed by authorized representatives of Infineon Technologies, Infineon Technologies products may not be used in any applications where a failure of the product or any consequences of the use thereof can reasonably be expected to result in personal injury.

## Looking for pricing, stock, or lifecycle information?

Click below to explore more details on WIN SOURCE:

- ⊖ [View BGSA400ML10E6327XTSA1 on WIN SOURCE](#)
- ⊖ [Infineon Technologies Information](#)

## Optimize Your Supply Chain with WIN SOURCE Solutions

- ✓ Global Sourcing Solution
- ✓ Obsolete Management
- ✓ Cost Control Management
- ✓ Shortage Management
- ✓ Alternative Solution
- ✓ Excess Inventory Management