



**THE DATASHEET OF
IS29GL256-70SLET**





IS29GL256

IS29GL128

256Mb/128Mb
3.0V PAGE MODE PARALLEL FLASH MEMORY

DATA SHEET

IS29GL256/128

256/128 Megabit Flash Memory

Page mode Flash Memory, CMOS 3.0 Volt-only

FEATURES

- Single power supply operation
 - Full voltage range: 2.7 to 3.6 volts read and write operations
- Fast Access Time at -40°C to +125°C:
 - 70ns⁽¹⁾ at V_{CC} = 3.0V~3.6V, V_{IO} = 3.0V~3.6V
 - V_{IO} Input/Output 1.65V to 3.6V.
 - All input levels (address, control, and DQ input levels) and outputs are determined by voltage on V_{IO} input.
- 8-word/16-byte page read buffer
- 32-word/64-byte write buffer reduces overall programming time for multiple-word updates
- Secured Silicon Region (SSR)
 - 512-word/1024-byte sector for permanent, secure identification
 - 256-word Factory Locked SSR and 256-word Customer Locked SSR
- Uniform 64Kword/128KByte Sector Architecture
- Suspend and Resume commands for Program and Erase operations
- Write operation status bits indicate program and erase operation completion
- Support for CFI (Common Flash Interface)
- Volatile and non-volatile methods of Advanced Sector Protection
- WP#/ACC input
 - Accelerates programming time (when V_{HH} is applied) for greater throughput during system production
- Protects first or last sector regardless of sector protection settings
- Hardware reset input (RESET#) resets device
- Ready/Busy# output (RY/BY#) detects program or erase cycle completion
- Minimum 100K program/erase endurance cycles.
- Data retention : 20 years (TYP)
- Package Options
 - 56-pin TSOP
 - 64-ball 13mm x 11mm BGA (Call Factory)
 - 64-ball 9mm x 9mm BGA
 - 56-ball 9mm x 7mm BGA (Call Factory)
- Temperature Range
 - Extended Grade: -40°C to +105°C
 - Automotive Grade: -40°C to +125°C

Note:

1. 80ns at V_{CC}=2.7V~3.6V, V_{IO}=2.7V~3.6V.
90ns at V_{CC}=2.7V~3.6V, V_{IO}=1.65V ~ V_{CC}.

GENERAL DESCRIPTION

The IS29GL256/128 offer a fast page access time of 20ns with a corresponding random access time as fast as 70ns. It features a Write Buffer that allows a maximum of 32 words/64 bytes to be programmed in one operation, resulting in faster effective programming time than standard programming algorithms. This makes the device ideal for today's embedded applications that require higher density, better performance and lower power consumption.

CONNECTION DIAGRAMS

Figure 1.1 56-pin Standard TSOP (Top View) ⁽¹⁾

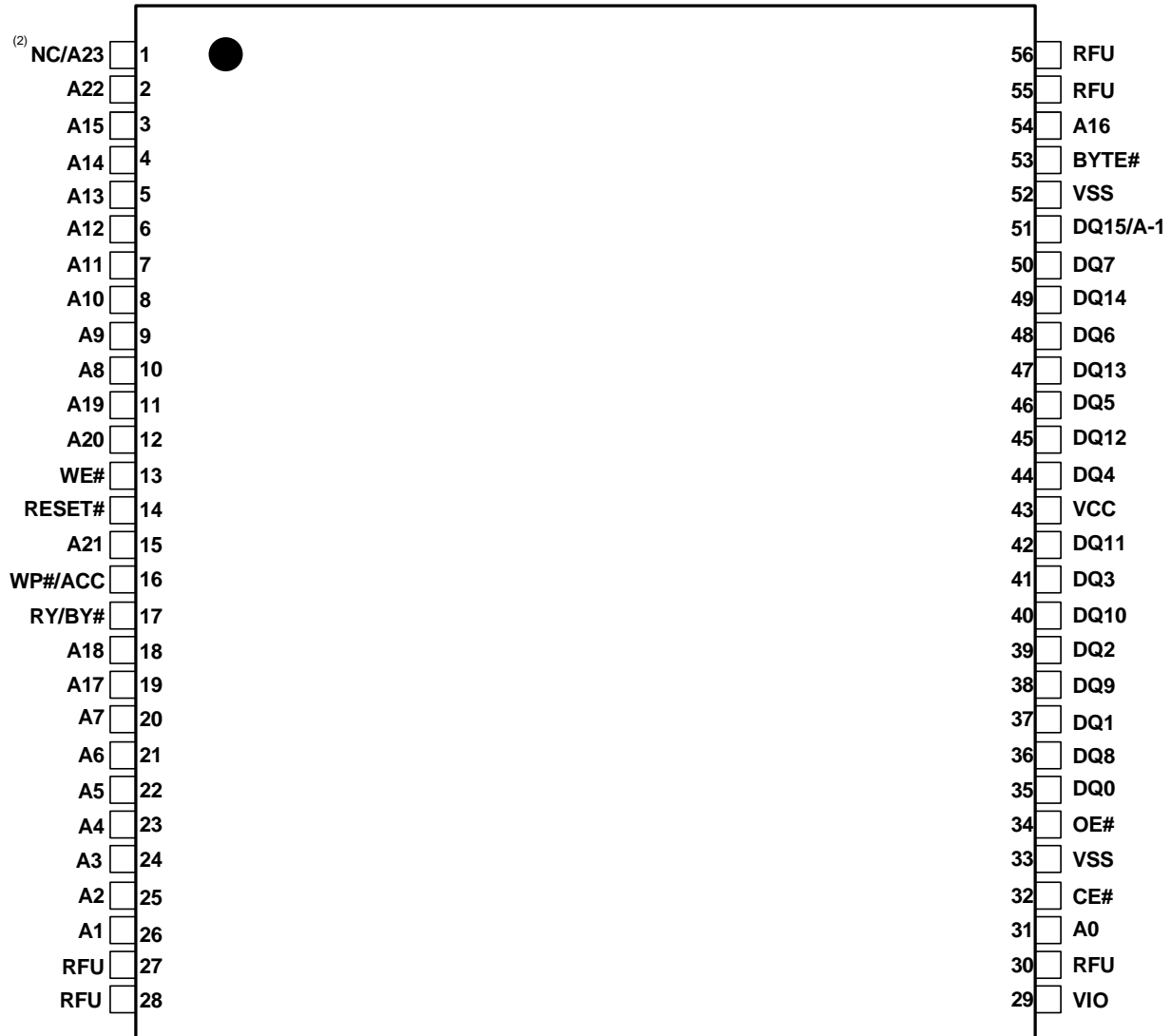

Notes:

1. RFU= Reserved for future use
2. NC for 128Mb

Figure 1.2 56-pin Standard TSOP (Top View) ⁽¹⁾, No BYTE#,

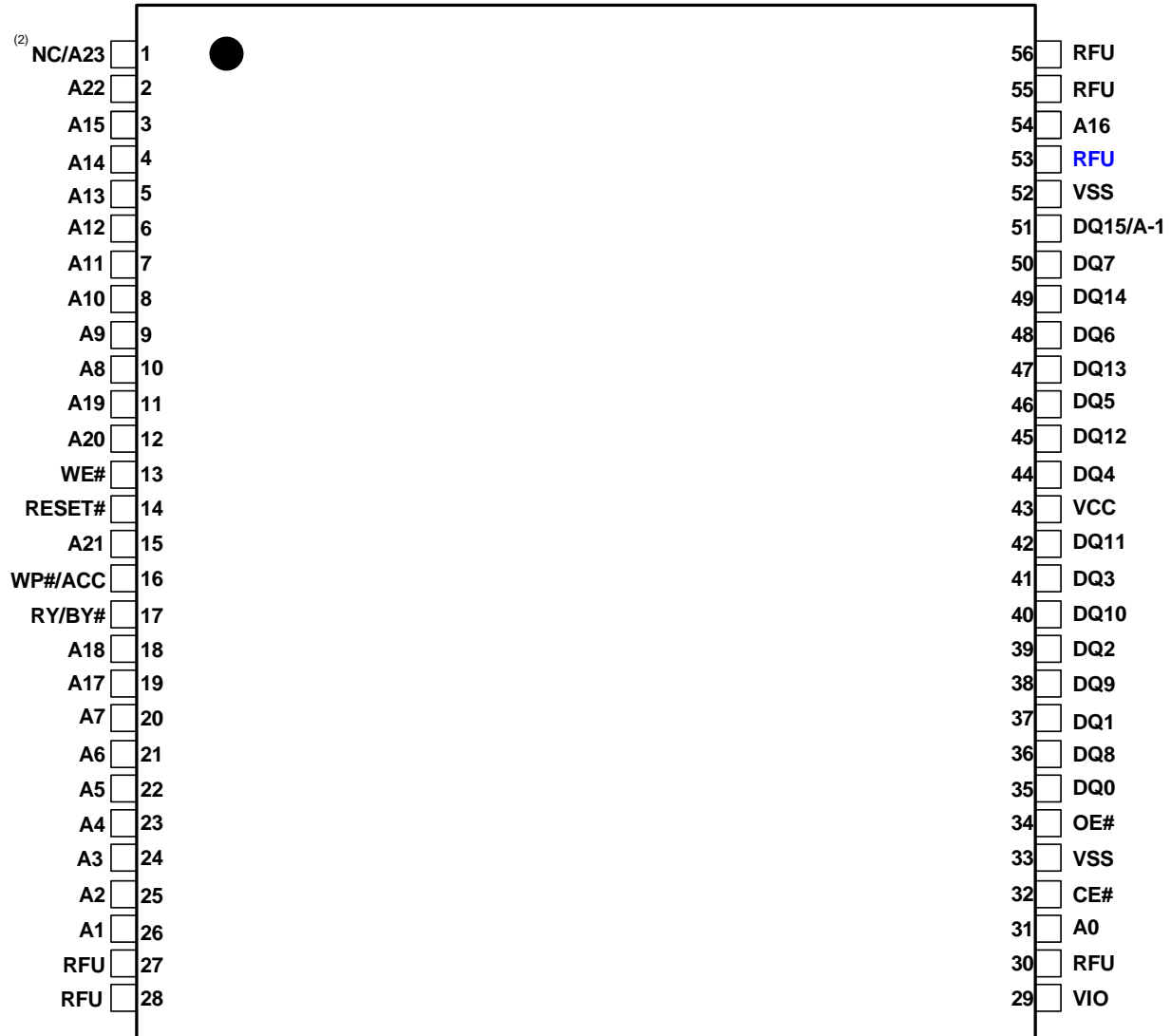

Notes:

1. RFU= Reserved for future use
2. NC for 128Mb

Figure 2.1 64-ball Ball Grid Array (Top View, Balls Facing Down) ⁽¹⁾

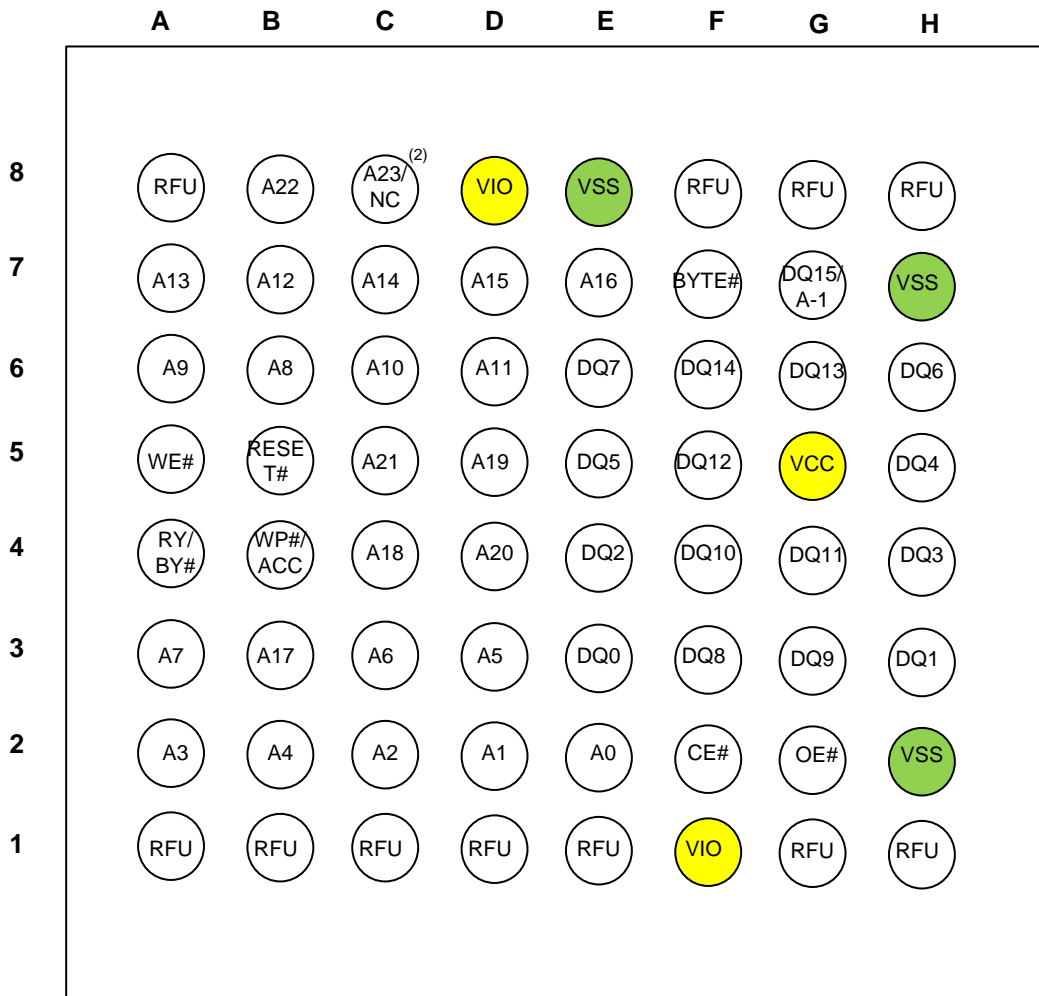

Notes:

1. RFU= Reserved for future use
2. NC for 128Mb

Figure 2.2 64-ball Ball Grid Array (Top View, Balls Facing Down)⁽¹⁾, NO BYTE#

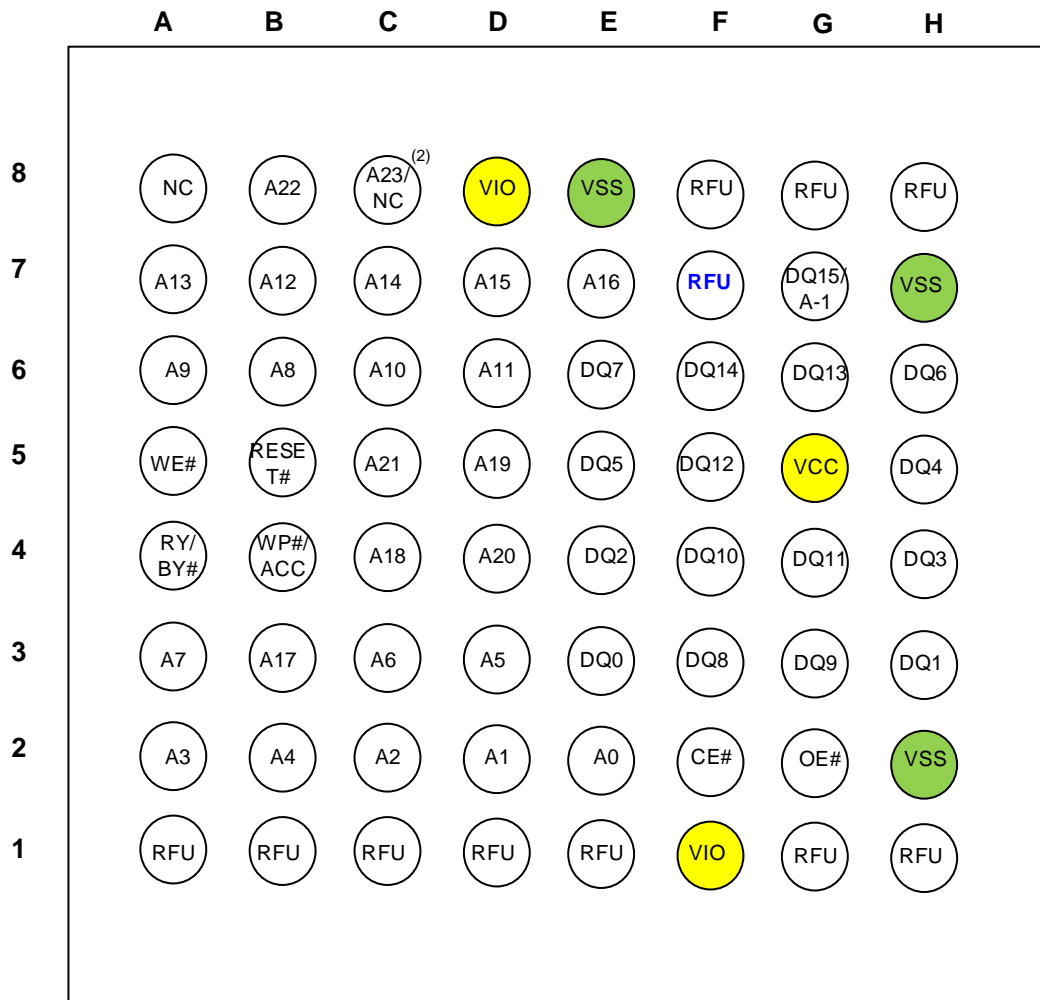
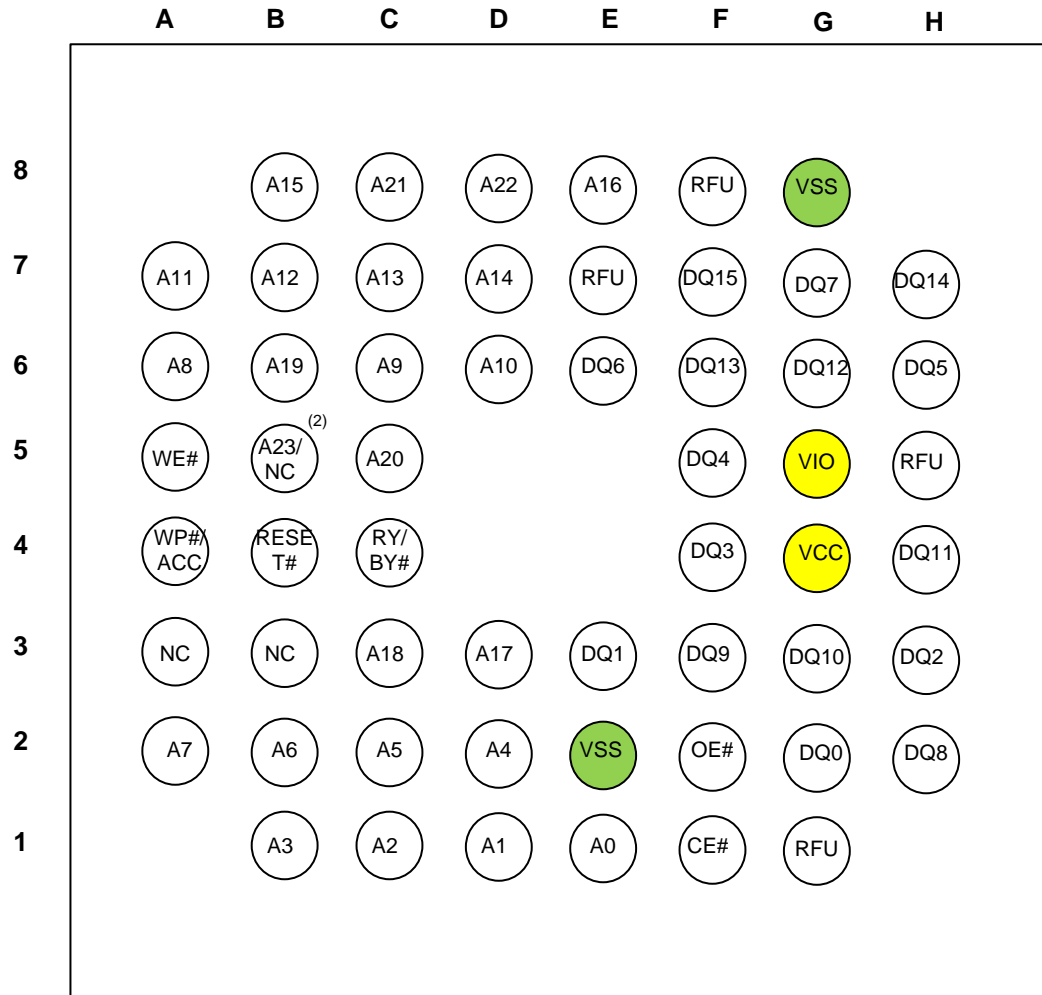

Figure 2-3. 56-ball Ball Grid Array (Top View, Balls Facing Down)⁽¹⁾, NO BYTE#



Notes:

1. RFU= Reserved for future use
2. NC for 128Mb

TABLE 1. PIN DESCRIPTION

Pin Name	Function
A23(A22)–A0	Address
DQ0-DQ14	Data input/output.
DQ15 / A-1	DQ15 (data input/output, word mode), A-1 (LSB address input, byte mode)
CE#	Chip Enable
OE#	Output Enable
RESET#	Hardware Reset Pin
RY/BY#	Ready/Busy Output
WE#	Write Enable
Vcc	Supply Voltage
Vss	Ground
V _{IO}	Supply Voltage for Input/Output.
BYTE# ⁽¹⁾	Byte/Word mode selection
WP#/ACC	Write Protect / Acceleration Pin (WP# has an internal pull-up; when unconnected, WP# is at V _{IH} .)
NC	No Connect
RFU	Reserved for future use. RFUs should not be connected.

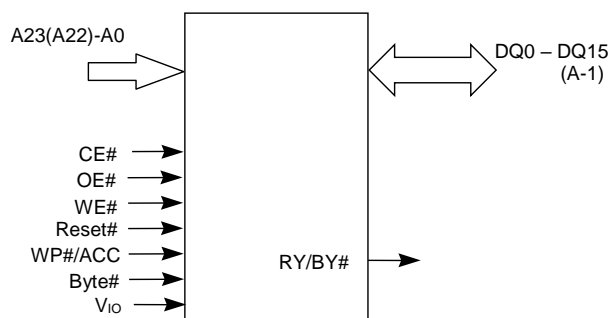
FIGURE 3. LOGIC DIAGRAM

Note:

1. No Byte# (x16 org. only) device is also available.

Table 2. PRODUCT SELECTOR GUIDE

Product Number	IS29GL256/128	
Maximum SPEED	70ns⁽¹⁾ at V_{CC} = 3.0V ~ 3.6V, V_{IO} = 3.0V ~ 3.6V	
Temperature	Extended (E)	-40°C to +105°C
	Automotive (A3)	40°C to +125°C

Note:

- Maximum speed becomes 80ns when V_{CC} = 2.7V ~ 3.6V, V_{IO} = 2.7V ~ 3.6V, and 90ns when V_{CC} = 2.7V ~ 3.6V, V_{IO} = 1.65V~V_{CC}.

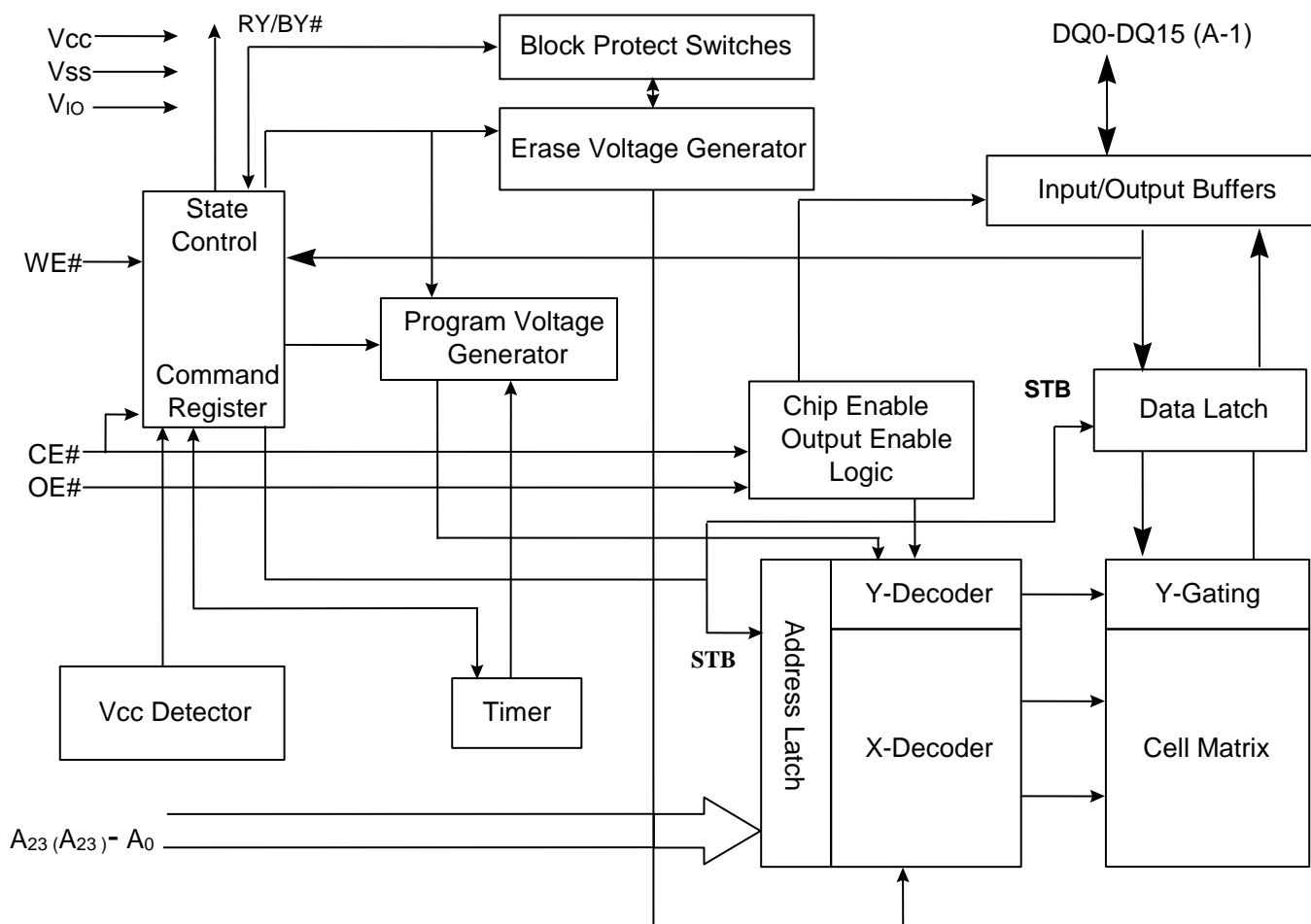
BLOCK DIAGRAM

Product Overview

IS29GL256/128 are 256/128 Mb, page mode Flash devices optimized for today's embedded designs that demand a large storage array and rich functionality. This product offers uniform 64 Kword (128 KB) sectors and feature $V_{I/O}$ control, allowing control and I/O signals to operate from 1.65 V to V_{CC} . Additional features include:

- Single word programming or a 32-word buffer for an increased programming speed
- Program Suspend/Resume and Erase Suspend/Resume
- Advanced Sector Protection methods for protecting sectors as required
- 512 words/1024 bytes of Secured Silicon Region for storing customer secured information. The Secured Silicon Region is One Time Programmable (OTP).

Table 3. Sector / Persistent Protection Sector Group Address Tables

Density		PPB Group	A23(A22)-A18	Sector	Sector Size (Kbytes / Kwords)	Address Range (h) Word mode (x16)
128Mb	256Mb	PPB 0	000000	SA0	128/64	000000–00FFFF
		PPB 1		SA1	128/64	010000–01FFFF
		PPB 2		SA2	128/64	020000–02FFFF
		PPB 3		SA3	128/64	030000–03FFFF
		PPB 4	000001	SA4	128/64	040000–04FFFF
		PPB 5		SA5	128/64	050000–05FFFF
		PPB 6		SA6	128/64	060000–06FFFF
		PPB 7		SA7	128/64	070000–07FFFF
		PPB 8	000010	SA8	128/64	080000–08FFFF
		PPB 9		SA9	128/64	090000–09FFFF
		PPB 10		SA10	128/64	0A0000–0AFFFF
		PPB 11		SA11	128/64	0B0000–0BFFFF
		PPB 12	000011	SA12	128/64	0C0000–0CFFFF
		PPB 13		SA13	128/64	0D0000–0DFFFF
		PPB 14		SA14	128/64	0E0000–0EFFFF
		PPB 15		SA15	128/64	0F0000–0FFFFF
		PPB 16	000100	SA16	128/64	100000–10FFFF
		PPB 17		SA17	128/64	110000–11FFFF
		PPB 18		SA18	128/64	120000–12FFFF
		PPB 19		SA19	128/64	130000–13FFFF
		PPB 20	000101	SA20	128/64	140000–14FFFF
		PPB 21		SA21	128/64	150000–15FFFF
		PPB 22		SA22	128/64	160000–16FFFF
		PPB 23		SA23	128/64	170000–17FFFF
		PPB 24	000110	SA24	128/64	180000–18FFFF
		PPB 25		SA25	128/64	190000–19FFFF
		PPB 26		SA26	128/64	1A0000–1AFFFF
		PPB 27		SA27	128/64	1B0000–1BFFFF
		PPB 28	000111	SA28	128/64	1C0000–1CFFFF
		PPB 29		SA29	128/64	1D0000–1DFFFF
		PPB 30		SA30	128/64	1E0000–1EFFFF
		PPB 31		SA31	128/64	1F0000–1FFFFF
		PPB 32	001000	SA32	128/64	200000–20FFFF
		PPB 33		SA33	128/64	210000–21FFFF
		PPB 34		SA34	128/64	220000–22FFFF
PPB 35	SA35	128/64		230000–23FFFF		

Density		PPB Group	A23(22)-A18	Sector	Sector Size (Kbytes / Kwords)	Address Range (h) Word mode (x16)
128Mb	256Mb	PPB 36	001001	SA36	128/64	240000–24FFFF
		PPB 37		SA37	128/64	250000–25FFFF
		PPB 38		SA38	128/64	260000–26FFFF
		PPB 39		SA39	128/64	270000–27FFFF
		PPB 40	001010	SA40	128/64	280000–28FFFF
		PPB 41		SA41	128/64	290000–29FFFF
		PPB 42		SA42	128/64	2A0000–2AFFFF
		PPB 43		SA43	128/64	2B0000–2BFFFF
		PPB 44	001011	SA44	128/64	2C0000–2CFFFF
		PPB 45		SA45	128/64	2D0000–2DFFFF
		PPB 46		SA46	128/64	2E0000–2EFFFF
		PPB 47		SA47	128/64	2F0000–2FFFFF
		PPB 48	001100	SA48	128/64	300000–30FFFF
		PPB 49		SA49	128/64	310000–31FFFF
		PPB 50		SA50	128/64	320000–32FFFF
		PPB 51		SA51	128/64	330000–33FFFF
		PPB 52	001101	SA52	128/64	340000–34FFFF
		PPB 53		SA53	128/64	350000–35FFFF
		PPB 54		SA54	128/64	360000–36FFFF
		PPB 55		SA55	128/64	370000–37FFFF
		PPB 56	001110	SA56	128/64	380000–38FFFF
		PPB 57		SA57	128/64	390000–39FFFF
		PPB 58		SA58	128/64	3A0000–3AFFFF
		PPB 59		SA59	128/64	3B0000–3BFFFF
		PPB 60	001111	SA60	128/64	3C0000–3CFFFF
		PPB 61		SA61	128/64	3D0000–3DFFFF
		PPB 62		SA62	128/64	3E0000–3EFFFF
		PPB 63		SA63	128/64	3F0000–3FFFFF
		PPB 64	010000	SA64	128/64	400000–40FFFF
		PPB 65		SA65	128/64	410000–41FFFF
		PPB 66		SA66	128/64	420000–42FFFF
		PPB 67		SA67	128/64	430000–43FFFF
		PPB 68	010001	SA68	128/64	440000–44FFFF
		PPB 69		SA69	128/64	450000–45FFFF
		PPB 70		SA70	128/64	460000–46FFFF
		PPB 71		SA71	128/64	470000–47FFFF



Density	PPB Group	A23(22)-A18	Sector	Sector Size (Kbytes / Kwords)	Address Range (h) Word mode (x16)
128Mb	256Mb	010010	SA72	128/64	480000-48FFFF
			SA73	128/64	490000-49FFFF
			SA74	128/64	4A0000-4AFFFF
			SA75	128/64	4B0000-4BFFFF
		010011	SA76	128/64	4C0000-4CFFFF
			SA77	128/64	4D0000-4DFFFF
			SA78	128/64	4E0000-4EFFFF
			SA79	128/64	4F0000-4FFFFF
		010100	SA80	128/64	500000-50FFFF
			SA81	128/64	510000-51FFFF
			SA82	128/64	520000-52FFFF
			SA83	128/64	530000-53FFFF
		010101	SA84	128/64	540000-54FFFF
			SA85	128/64	550000-55FFFF
			SA86	128/64	560000-56FFFF
			SA87	128/64	570000-57FFFF
		010110	SA88	128/64	580000-58FFFF
			SA89	128/64	590000-59FFFF
			SA90	128/64	5A0000-5AFFFF
			SA91	128/64	5B0000-5BFFFF
		010111	SA92	128/64	5C0000-5CFFFF
			SA93	128/64	5D0000-5DFFFF
			SA94	128/64	5E0000-5EFFFF
			SA95	128/64	5F0000-5FFFFF
		011000	SA96	128/64	600000-60FFFF
			SA97	128/64	610000-61FFFF
			SA98	128/64	620000-62FFFF
			SA99	128/64	630000-63FFFF
011001	SA100	128/64	640000-64FFFF		
	SA101	128/64	650000-65FFFF		
	SA102	128/64	660000-66FFFF		
	SA103	128/64	670000-67FFFF		
011010	SA104	128/64	680000-68FFFF		
	SA105	128/64	690000-69FFFF		
	SA106	128/64	6A0000-6AFFFF		
	SA107	128/64	6B0000-6BFFFF		



Density	PPB Group	A23(22)-A18	Sector	Sector Size (Kbytes / Kwords)	Address Range (h) Word mode (x16)
128Mb	256Mb	011011	SA108	128/64	6C0000-6CFFFF
			SA109	128/64	6D0000-6DFFFF
			SA110	128/64	6E0000-6EFFFF
			SA111	128/64	6F0000-6FFFFFFF
		011100	SA112	128/64	700000-70FFFF
			SA113	128/64	710000-71FFFF
			SA114	128/64	720000-72FFFF
			SA115	128/64	730000-73FFFF
		011101	SA116	128/64	740000-74FFFF
			SA117	128/64	750000-75FFFF
			SA118	128/64	760000-76FFFF
			SA119	128/64	770000-77FFFF
		011110	SA120	128/64	780000-78FFFF
			SA121	128/64	790000-79FFFF
			SA122	128/64	7A0000-7AFFFF
			SA123	128/64	7B0000-7BFFFF
		011111	SA124	128/64	7C0000-7CFFFF
			SA125	128/64	7D0000-7DFFFF
			SA126	128/64	7E0000-7EFFFF
			SA127	128/64	7F0000-7FFFFFFF
		100000	SA128	128/64	800000-80FFFF
			SA129	128/64	810000-81FFFF
			SA130	128/64	820000-82FFFF
			SA131	128/64	830000-83FFFF
		100001	SA132	128/64	840000-84FFFF
			SA133	128/64	850000-85FFFF
			SA134	128/64	860000-86FFFF
			SA135	128/64	870000-87FFFF
100010	SA136	128/64	880000-88FFFF		
	SA137	128/64	890000-89FFFF		
	SA138	128/64	8A0000-8AFFFF		
	SA139	128/64	8B0000-8BFFFF		
100011	SA140	128/64	8C0000-8CFFFF		
	SA141	128/64	8D0000-8DFFFF		
	SA142	128/64	8E0000-8EFFFF		
	SA143	128/64	8F0000-8FFFFFFF		

Density	PPB Group	A23-A18	Sector	Sector Size (Kbytes / Kwords)	Address Range (h) Word mode (x16)
256Mb	PPB 144	100100	SA144	128/64	900000–90FFFF
	PPB 145		SA145	128/64	910000–91FFFF
	PPB 146		SA146	128/64	920000–92FFFF
	PPB 147		SA147	128/64	930000–93FFFF
	PPB 148	100101	SA148	128/64	940000–94FFFF
	PPB 149		SA149	128/64	950000–95FFFF
	PPB 150		SA150	128/64	960000–96FFFF
	PPB 151		SA151	128/64	970000–97FFFF
	PPB 152	100110	SA152	128/64	980000–98FFFF
	PPB 153		SA153	128/64	990000–99FFFF
	PPB 154		SA154	128/64	9A0000–9AFFFF
	PPB 155		SA155	128/64	9B0000–9BFFFF
	PPB 156	100111	SA156	128/64	9C0000–9CFFFF
	PPB 157		SA157	128/64	9D0000–9DFFFF
	PPB 158		SA158	128/64	9E0000–9EFFFF
	PPB 159		SA159	128/64	9F0000–9FFFFFFF
	PPB 160	101000	SA160	128/64	A00000–A0FFFF
	PPB 161		SA161	128/64	A10000–A1FFFF
	PPB 162		SA162	128/64	A20000–A2FFFF
	PPB 163		SA163	128/64	A30000–A3FFFF
	PPB 164	101001	SA164	128/64	A40000–A4FFFF
	PPB 165		SA165	128/64	A50000–A5FFFF
	PPB 166		SA166	128/64	A60000–A6FFFF
	PPB 167		SA167	128/64	A70000–A7FFFF
	PPB 168	101010	SA168	128/64	A80000–A8FFFF
	PPB 169		SA169	128/64	A90000–A9FFFF
	PPB 170		SA170	128/64	AA0000–AAFFFF
	PPB 171		SA171	128/64	AB0000–ABFFFF
	PPB 172	101011	SA172	128/64	AC0000–ACFFFF
PPB 173	SA173		128/64	AD0000–ADFFFF	
PPB 174	SA174		128/64	AE0000–AEFFFF	
PPB 175	SA175		128/64	AF0000–AFFFFFFF	
PPB 176	101100	SA176	128/64	B00000–B0FFFF	
PPB 177		SA177	128/64	B10000–B1FFFF	
PPB 178		SA178	128/64	B20000–B2FFFF	
PPB 179		SA179	128/64	B30000–B3FFFF	

Density	PPB Group	A23-A18	Sector	Sector Size (Kbytes / Kwords)	Address Range (h) Word mode (x16)
256Mb	PPB 180	101101	SA180	128/64	B40000–B4FFFF
	PPB 181		SA181	128/64	B50000–B5FFFF
	PPB 182		SA182	128/64	B60000–B6FFFF
	PPB 183		SA183	128/64	B70000–B7FFFF
	PPB 184	101110	SA184	128/64	B80000–B8FFFF
	PPB 185		SA185	128/64	B90000–B9FFFF
	PPB 186		SA186	128/64	BA0000–BAFFFF
	PPB 187		SA187	128/64	BB0000–BBFFFF
	PPB 188	101111	SA188	128/64	BC0000–BCFFFF
	PPB 189		SA189	128/64	BD0000–BDFFFF
	PPB 190		SA190	128/64	BE0000–BEFFFF
	PPB 191		SA191	128/64	BF0000–BFFFFF
	PPB 192	110000	SA192	128/64	C00000–C0FFFF
	PPB 193		SA193	128/64	C10000–C1FFFF
	PPB 194		SA194	128/64	C20000–C2FFFF
	PPB 195		SA195	128/64	C30000–C3FFFF
	PPB 196	110001	SA196	128/64	C40000–C4FFFF
	PPB 197		SA197	128/64	C50000–C5FFFF
	PPB 198		SA198	128/64	C60000–C6FFFF
	PPB 199		SA199	128/64	C70000–C7FFFF
	PPB 200	110010	SA200	128/64	C80000–C8FFFF
	PPB 201		SA201	128/64	C90000–C9FFFF
	PPB 202		SA202	128/64	CA0000–CAFFFF
	PPB 203		SA203	128/64	CB0000–CBFFFF
	PPB 204	110011	SA204	128/64	CC0000–CCFFFF
PPB 205	SA205		128/64	CD0000–CDFFFF	
PPB 206	SA206		128/64	CE0000–CEFFFF	
PPB 207	SA207		128/64	CF0000–CFFFFF	
PPB 208	110100	SA208	128/64	D00000–D0FFFF	
PPB 209		SA209	128/64	D10000–D1FFFF	
PPB 210		SA210	128/64	D20000–D2FFFF	
PPB 211		SA211	128/64	D30000–D3FFFF	
PPB 212	110101	SA212	128/64	D40000–D4FFFF	
PPB 213		SA213	128/64	D50000–D5FFFF	
PPB 214		SA214	128/64	D60000–D6FFFF	
PPB 215		SA215	128/64	D70000–D7FFFF	

Density	PPB Group	A23-A18	Sector	Sector Size (Kbytes / Kwords)	Address Range (h) Word mode (x16)
256Mb	PPB 216	110110	SA216	128/64	D80000–D8FFFF
	PPB 217		SA217	128/64	D90000–D9FFFF
	PPB 218		SA218	128/64	DA0000–DAFFFF
	PPB 219		SA219	128/64	DB0000–DBFFFF
	PPB 220	110111	SA220	128/64	DC0000–DCFFFF
	PPB 221		SA221	128/64	DD0000–DDFFFF
	PPB 222		SA222	128/64	DE0000–DEFFFF
	PPB 223		SA223	128/64	DF0000–DFFFFFFF
	PPB 224	111000	SA224	128/64	E00000–E0FFFF
	PPB 225		SA225	128/64	E10000–E1FFFF
	PPB 226		SA226	128/64	E20000–E2FFFF
	PPB 227		SA227	128/64	E30000–E3FFFF
	PPB 228	111001	SA228	128/64	E40000–E4FFFF
	PPB 229		SA229	128/64	E50000–E5FFFF
	PPB 230		SA230	128/64	E60000–E6FFFF
	PPB 231		SA231	128/64	E70000–E7FFFF
	PPB 232	111010	SA232	128/64	E80000–E8FFFF
	PPB 233		SA233	128/64	E90000–E9FFFF
	PPB 234		SA234	128/64	EA0000–EAFFFF
	PPB 235		SA235	128/64	EB0000–EBFFFF
	PPB 236	111011	SA236	128/64	EC0000–ECFFFF
	PPB 237		SA237	128/64	ED0000–EDFFFF
	PPB 238		SA238	128/64	EE0000–EEFFFF
	PPB 239		SA239	128/64	EF0000–EFFFFFFF
	PPB 240	111100	SA240	128/64	F00000–F0FFFF
	PPB 241		SA241	128/64	F10000–F1FFFF
	PPB 242		SA242	128/64	F20000–F2FFFF
PPB 243	SA243		128/64	F30000–F3FFFF	
PPB 244	111101	SA244	128/64	F40000–F4FFFF	
PPB 245		SA245	128/64	F50000–F5FFFF	
PPB 246		SA246	128/64	F60000–F6FFFF	
PPB 247		SA247	128/64	F70000–F7FFFF	

Density	PPB Group	A23-A18	Sector	Sector Size (Kbytes / Kwords)	Address Range (h) Word mode (x16)
256Mb	PPB 248	111110	SA248	128/64	F80000–F8FFFF
	PPB 249		SA249	128/64	F90000–F9FFFF
	PPB 250		SA250	128/64	FA0000–FAFFFF
	PPB 251		SA251	128/64	FB0000–FBFFFF
	PPB 252	111111	SA252	128/64	FC0000–FCFFFF
	PPB 253		SA253	128/64	FD0000–FDFFFF
	PPB 254		SA254	128/64	FE0000–FEFFFF
	PPB 255		SA255	128/64	FF0000–FFFFFF

Table 4. Device OPERATING MODES
256/128Mb FLASH USER MODE TABLE

Operation	CE#	OE#	WE#	RESET#	WP#/ ACC	A23(22)- A0	DQ0- DQ7	DQ8-DQ15	
								BYTE# = V _{IH}	BYTE# = V _{IL}
Read	L	L	H	H	L/H	A _{IN}	D _{OUT}	D _{OUT}	DQ8- DQ14 =High-Z, DQ15=A-1
Write	L	H	L	H	(Note 2)	A _{IN}	D _{IN}	D _{IN}	
Accelerated Program	L	H	L	H	V _{HH}	A _{IN}	D _{IN}	D _{IN}	
CMOS Standby	V _{CC} ±0.3V	X	X	V _{CC} ±0.3V	H	X	High-Z	High-Z	High-Z
Output Disable	L	H	H	H	L/H	X	High-Z	High-Z	High-Z
Hardware Reset	X	X	X	L	L/H	X	High-Z	High-Z	High-Z

Notes:

- Addresses are A23 (A22)-A0 in word mode; A23 (A22)-A-1 in byte mode.
- If WP# = V_{IL}, only the outermost sector remains protected. If WP# = V_{IH}, the outermost sector is unprotected. WP# has a resistive pullup controlled by a latch, which is reset to the V_{IH} state during V_{CC} power up; when unconnected, WP# will remain at V_{IH}. Most sectors are unprotected when shipped from the factory. But the Factory Locked Secured Silicon Region is always factory locked when shipped from the factory.
- D_{IN} or D_{OUT} as required by command sequence, data polling, or sector protect algorithm.

Legend

L = Logic Low = V_{IL}, H = Logic High = V_{IH}, V_{HH} = 8.5–9.5V, X = Don't Care, A_{IN} = Address In, D_{IN} = Data In, D_{OUT} = Data Out

USER MODE DEFINITIONS

Word / Byte Configuration

The BYTE# pin controls whether the device data I/O pins operate in the byte or word configuration. If the BYTE# pin is set at logic '1', the device is in word configuration, DQ0-DQ15 are active and controlled by CE#, OE#, and WE#.

If the BYTE# pin is set at logic '0', the device is in byte configuration, and only data I/O pins DQ0-DQ7 are active and controlled by CE#, OE#, and WE#. The data I/O pins DQ8-DQ14 are tri-stated, and the DQ15 pin is used as an input for the LSB (A-1) address function.

V_{IO} Control

The V_{IO} allows the host system to set the voltage levels that the device generates and tolerates on all inputs and outputs (address, control, and DQ signals). V_{IO} range is 1.65 to V_{CC}. For example, a V_{IO} of 1.65-3.6 volts allows for I/O at the 1.65 or 3.6 volt levels, driving and receiving signals to and from other 1.65 or 3.6 V devices on the same data bus.

Read

All memories require access time to output array data. In a read operation, data is read from one memory location at a time. Addresses are presented to the device in random order, and the propagation delay through the device causes the data on its outputs to arrive with the address on its inputs.

The device defaults to reading array data after device power-up or hardware reset. To read data from the memory array, the system must first assert a valid address on A23-A0, while driving OE# and CE# to VIL. WE# must remain at VIH. Data will appear on DQ15-DQ0 after address access time (t_{ACC}), which is equal to the delay from stable addresses to valid output data. The OE# signal must be driven to VIL. Data is output on DQ15-DQ0 pins after the access time (t_{OE}) has elapsed from the falling edge of OE#, assuming the t_{ACC} access time has been met.

Page Read Mode

The device is capable of fast page mode read and is compatible with the page mode Mask ROM read operation. This mode provides faster read access speed for random locations within a page. The page size of the device is 8 words/16 bytes. The appropriate page is selected by the higher address bits A23-A3. Address bits A2-A0 in word mode (A2 to A-1 in byte mode) determine the specific word within a page. The microprocessor supplies the specific word location.

The random or initial page access is equal to t_{ACC} or t_{CE} and subsequent page read accesses (as long as the locations specified by the microprocessor falls within that page) is equivalent to t_{PACC}. When CE# is deasserted and reasserted for a subsequent access, the access time is t_{ACC} or t_{CE}. Fast page mode accesses are obtained by keeping the "read-page addresses" constant and changing the "intra-read page" addresses.

Autoselect

The Autoselect mode provides manufacturer ID, Device identification, and sector protection information, through identifier codes output from the internal register (separate from the memory array) on the DQ pins.

The device only support to use Autoselect command to access Autoselect codes. It does not support the mode of applying V_{HH} on address pin A9.

- The Autoselect command sequence may be written to an address within a sector that is either in the read or erase-suspend-read mode.
- The Autoselect command may not be written while the device is actively programming or erasing.
- The system must write the reset command to return to the read mode (or erase-suspend-read mode if the sector was previously in Erase Suspend).
- When verifying sector protection, the sector address must appear on the appropriate highest order address bits. The remaining address bits are don't care and then read the corresponding identifier code on DQ pins.

		Address		Data(Hex)	Remark
Manufacturer ID		Word	X00	9D	
		Byte	X00	9D	
Device ID	256Mb	Word	X01/X0E/X0F	227E/2222/2201	
		Byte	X02/X1C/X1E	7E/22/01	
	128Mb	Word	X01/X0E/X0F	227E/2221/2201	
		Byte	X02/X1C/X1E	7E/21/01	

Program/Erase Operations

These devices are capable of several modes of programming and or erase operations which are described in detail in the following sections.

During a write operation, the system must drive CE# and WE# to VIL and OE# to VIH when providing address, command, and data. Addresses are latched on the falling edge of WE# or CE#, whichever is last, while data is latched on the rising edge of WE# or CE#, whichever is first.

Note the following:

- When the Embedded Program algorithm is complete, the device returns to the read mode.
- The system can determine the status of the program operation by reading the DQ status bits. Refer to "Write Operation Status" for information on these status bits.
- An "0" cannot be programmed back to a "1." A succeeding read shows that the data is still "0."
- Only erase operations can convert a "0" to a "1."
- Any commands written to the device during the Embedded Program/Erase are ignored except the Suspend commands.
- Secured Silicon Region, Autoselect, and CFI functions are unavailable when a program operation is in progress.
- A hardware reset and/or power removal immediately terminates the Program/Erase operation and the Program/Erase command sequence should be reinitiated once the device has returned to the read mode to ensure data integrity.
- Programming is allowed in any sequence and across sector boundaries for single word programming operation.
- Programming to the same word address multiple times without intervening erases is permitted.

Single Word Programming

Single word programming mode is one method of programming the Flash. In this mode, four Flash command write cycles are used to program an individual Flash address. The data for this programming operation could be 8 or 16-bits wide.

While the single word programming method is supported by most devices, in general Single Word Programming is not recommended for devices that support Write Buffer Programming.

When the Embedded Program algorithm is complete, the device then returns to the read mode and addresses are no longer latched. The system can determine the status of the program operation by reading the DQ status bits.

- During programming, any command (except the Suspend command) is ignored.
- The Secured Silicon Region, Autoselect, and CFI functions are unavailable when a program operation is in progress.
- A hardware reset immediately terminates the program operation. The program command sequence should be reinitiated once the device has returned to the read mode, to ensure data integrity.
- Programming to the same address multiple times continuously (for example, “walking” a bit within a word) is permitted.

Figure 4. Single Word Program

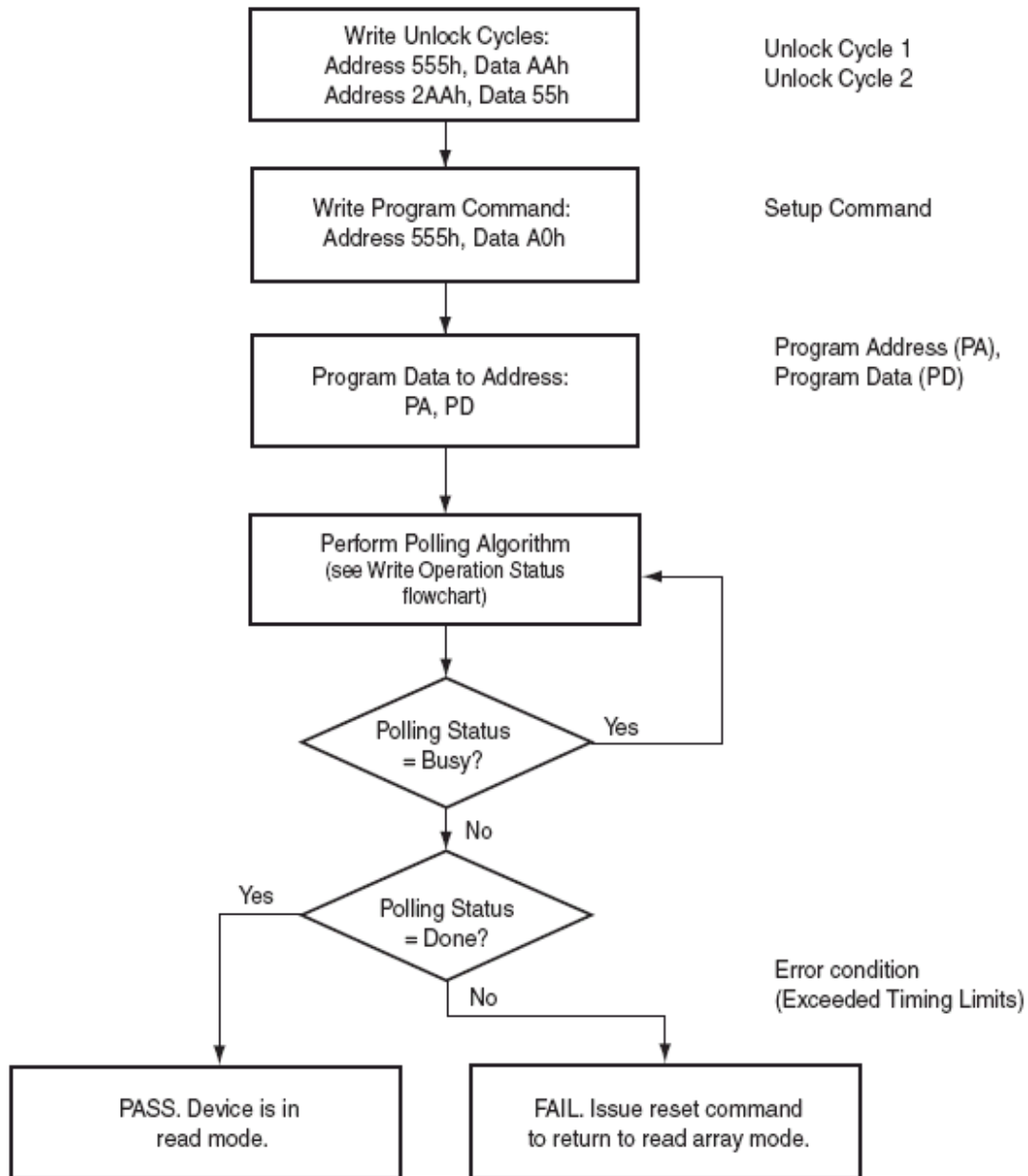

Write Buffer Programming

Write Buffer Programming allows the system to write a maximum of 32 words in one programming operation. This results in a faster effective word programming time than the standard “word” programming algorithms. The Write Buffer Programming command sequence is initiated by first writing two unlock cycles. This is followed by a third write cycle containing the Write Buffer Load command written at the Sector Address in which programming occurs. At this point, the system writes the number of “word locations minus 1” that are loaded into the write buffer at the Sector Address in which programming occurs. This tells the device how many write buffer addresses are loaded with data and therefore when to expect the “Program Buffer to Flash” confirm command. The number of locations to program cannot exceed the size of the write buffer or the operation aborts. (Number loaded = the number of locations to program minus 1. For example, if the system programs 6 address locations, then 05h should be written to the device.)

The system then writes the starting address/data combination. This starting address is the first address/data pair to be programmed, and selects the “write-buffer-page” address. All subsequent address/data pairs must fall within the elected-write-buffer-page.

The “write-buffer-page” is selected by using the addresses A23–A5.

The “write-buffer-page” addresses must be the same for all address/data pairs loaded into the write buffer. (This means Write Buffer Programming cannot be performed across multiple “write-buffer-pages.” This also means that Write Buffer Programming cannot be performed across multiple sectors. If the system attempts to load programming data outside of the selected “write-buffer-page”, the operation ABORTs.)

After writing the Starting Address/Data pair, the system then writes the remaining address/data pairs into the write buffer.

Note that if a Write Buffer address location is loaded multiple times, the “address/data pair” counter is decremented for every data load operation. Also, the last data loaded at a location before the “Program Buffer to Flash” confirm command is the data programmed into the device. It is the software’s responsibility to comprehend ramifications of loading a write-buffer location more than once. The counter decrements for each data load operation, NOT for each unique write-buffer-address location. Once the specified number of write buffer locations have been loaded, the system must then write the “Program Buffer to Flash” command at the Sector Address. Any other address/data write combinations abort the Write Buffer Programming operation. The Write Operation Status bits should be used while monitoring the last address location loaded into the write buffer. This eliminates the need to store an address in memory because the system can load the last address location, issue the program confirm command at the last loaded address location, and then check the write operation status at that same address. DQ7, DQ6, DQ5, DQ2, and DQ1 should be monitored to determine the device status during Write Buffer Programming.

The write-buffer “embedded” programming operation can be suspended or resumed using the standard suspend/resume commands. Upon successful completion of the Write Buffer Programming operation, the device returns to READ mode.

The Write Buffer Programming Sequence is ABORTED under any of the following conditions:

- Load a value that is greater than the page buffer size during the “Number of Locations to Program” step.
- Write to an address in a sector different than the one specified during the Write-Buffer-Load command.
- Write an Address/Data pair to a different write-buffer-page than the one selected by the “Starting Address” during the “write buffer data loading” stage of the operation.
- Writing anything other than the Program to Buffer Flash Command after the specified number of “data load” cycles.

The ABORT condition is indicated by DQ1 = 1, DQ7 = DATA# (for the “last address location loaded”), DQ6 = TOGGLE, DQ5 = 0. This indicates that the Write Buffer Programming Operation was ABORTED. Note that the Secured Silicon Region, Autoselect, and CFI functions are unavailable when a program operation is in progress.

Write buffer programming is allowed in any sequence of write buffer page locations. These flash devices are capable of handling multiple write buffer programming operations on the same write buffer address range without intervening erases.

Use of the write buffer is strongly recommended for programming when multiple words are to be programmed.

Figure 5. Write Buffer Programming Operation

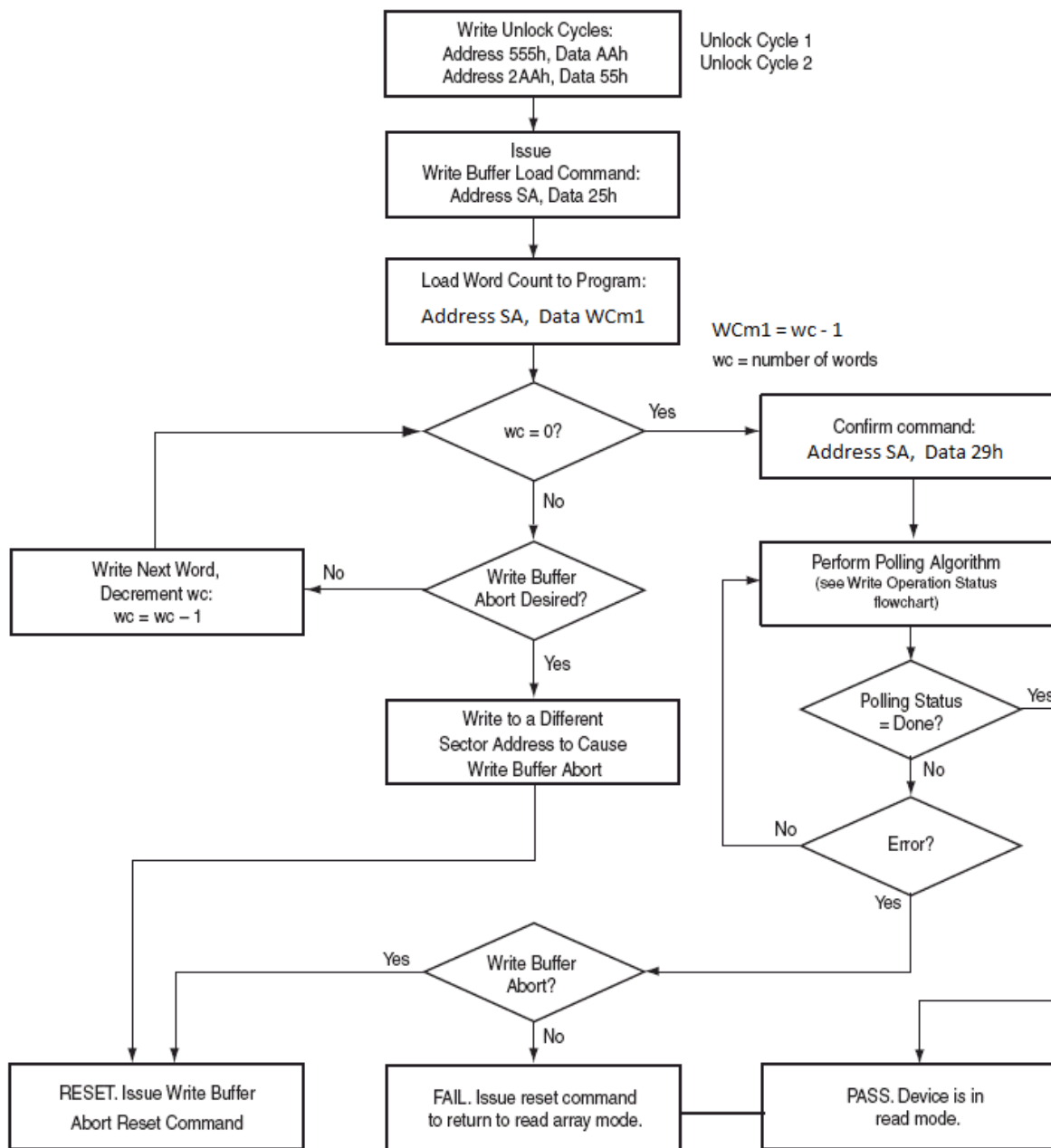

Sector Erase

Sector erase is a six bus cycle operation. The sector erase command sequence is initiated by writing two un-lock cycles, followed by a set-up command. Two additional unlock write cycles are then followed by the address of the sector to be erased, with the sector erase command. The Command Definitions table shows the address and data requirements for the sector erase command sequence.

Once the sector erase operation has begun, only Suspend command (B0h) is valid. All other commands are ignored. If there are several sectors to be erased, Sector Erase Command sequences must be issued for each sector. That is, only one sector address can be specified for each Sector Erase command. Users must issue another Sector Erase command for the next sector to be erased after the previous one is completed.

When the Embedded Erase algorithm is completed, the device returns to reading array data and addresses are no longer latched. The system can determine the status of the erase operation by using DQ7, DQ6, or DQ2. Refer to “Write Operation Status” for information on these status bits. Flowchart on Figure 6 illustrates the algorithm for the erase operation. Refer to the Erase/Program Operations tables in the “AC Characteristics” section for parameters, and to the Sector Erase Operations Timing diagram for timing waveforms.

Figure 6. Sector Erase Operation

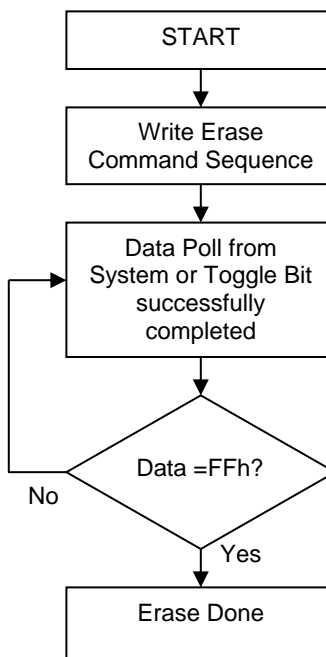

Chip Erase Command Sequence

Chip erase is a six-bus cycle operation as indicated by Table 13. These commands invoke the Embedded Erase algorithm, which does not require the system to preprogram prior to erase. The Embedded Erase algorithm automatically preprograms and verifies the entire memory to an all zero data pattern prior to electrical erase. After a successful chip erase, all locations of the chip contain FFFFh, except for any protected sectors. The system is not required to provide any controls or timings during these operations.

When the Embedded Erase algorithm is complete, that sector returns to the read mode and addresses are no longer latched. The system can determine the status of the erase operation by using DQ7 or DQ6/DQ2. Refer to “Write Operation Status” for information on these status bits.

Any commands including suspend command written during the chip erase operation are ignored. However, note that a hardware reset immediately terminates the erase operation. If that occurs, the chip erase command sequence should be reinitiated once that sector has returned to reading array data, to ensure the entire array is properly erased.

Erase Suspend/Erase Resume Sequence

The Suspend command (B0h) allows the system to interrupt a sector erase operation and then read data from, or program data to, any sector not selected for erase. The Suspend command is ignored if written during the chip erase operation. Addresses are don't-cares when writing the Suspend command during sector erase operation.

When the Suspend command is written during the sector erase operation, the device requires a maximum of 20 μ s to suspend the erase operation.

After the sector erase operation has been suspended, the device enters the erase-suspend-read mode. The system can read data from or program data to any sector not selected for erasure. (The device “erase suspends” all sectors selected for erasure.) Reading at any address within erase-suspended sectors produces status information on DQ7-DQ0. The system can use DQ7, or DQ6, and DQ2 together, to determine if a sector is actively erasing or is erase-suspended.

In the erase-suspend-read mode, the system can also issue Programming commands, the Autoselect command sequence, the Secured Silicon Region command, and CFI query command. Refer to Write Buffer Programming and the Autoselect for details.

To resume the sector erase operation, the system must write the Resume command (30h). Further writes of the Resume command are ignored. Another Suspend command can be written after the chip has resumed sector erasing

Program Suspend/Program Resume Sequence

The Suspend command (B0h) also allows the system to interrupt an embedded programming operation or a “Write to Buffer” programming operation so that data can read from any non-suspended sector. When the Program Suspend command is written during a programming process, the device halts the programming operation within 15 μ s maximum (5 μ s typical) and updates the status bits. Addresses are “don't-cares” when writing the Suspend command.

After the programming operation has been suspended, the system can read array data from any non-suspended sector. The Suspend command may also be issued during a programming operation while an erase is suspended. In this case, data may be read from any addresses not within a sector in Erase Suspend or Program Suspend. If a read is needed from the Secured Silicon Region, then user must use the proper command sequences to enter and exit this region.

The system may also write the Autoselect Command Sequence and CFI query command when the device is in Program Suspend mode. The device allows reading Autoselect codes in the suspended sectors, since the codes are not stored in the memory array. When the device exits the Autoselect mode, the device reverts to Program Suspend mode, and is ready for another valid operation.

After the Program Resume command is written, the device reverts to programming. The system can determine the status of the program operation using the write operation status bits, just as in the standard program operation.

The system must write the Resume command (30h) to exit the Program Suspend mode (address bits are “don't care”) and continue the programming operation. Further writes of the Resume command are ignored. Another Suspend command can be written after the device has resumed programming.

Accelerated Program

Accelerated single word programming and write buffer programming operations are enabled through the WP#/ACC pin. This method is faster than the standard program command sequences.

If the system asserts V_{HH} on this input, the device automatically enters the Accelerated Program mode and uses the higher voltage and current provided by WP#/ACC pin to reduce the time required for program operations. The system can then use the Write Buffer Load command sequence provided by the Accelerated Program mode. Note that if a “Write-to-Buffer-Abort Reset” is required while in Accelerated Program mode, the full 3-cycle RESET command sequence must be used to reset the device. Removing V_{HH} from the ACC input, upon completion of the embedded program operation, returns the device to normal operation.

- Sectors must be unlocked prior to raising WP#/ACC to V_{HH} .
- The WP#/ACC pin must not be at V_{HH} for operations other than accelerated programming, or device damage may result.
- It is recommended that WP#/ACC apply V_{HH} after power-up sequence is completed. In addition, it is recommended that WP#/ACC apply from V_{HH} to V_{IH}/V_{IL} before powering down V_{CC}/V_{IO} .

Write Operation Status

The device provides several bits to determine the status of a program or erase operation. The following subsections describe the function of DQ1, DQ2, DQ3, DQ5, DQ6, and DQ7.

DQ7: Data# Polling

The Data# Polling bit, DQ7, indicates to the host system whether an Embedded Program or Erase algorithm is in progress or completed, or whether the device is in Erase Suspend. Data# Polling is valid after the rising edge of the final WE# pulse in the command sequence. Note that the Data# Polling is valid only for the last word being programmed in the write-buffer-page during Write Buffer Programming. Reading Data# Polling status on any word other than the last word to be programmed in the write-buffer-page returns false status information.

During the Embedded Program algorithm, the device outputs on DQ7 the complement of the datum programmed to DQ7. This DQ7 status also applies to programming during Erase Suspend. When the Embedded Program algorithm is complete, the device outputs the datum programmed to DQ7. The system must provide the program address to read valid status information on DQ7. If a program address falls within a protected sector, Data# polling on DQ7 is active, then that sector returns to the read mode, without changing any data.

During the Embedded Erase Algorithm, Data# polling produces a “0” on DQ7. When the Embedded Erase algorithm is complete, or if the device enters the Erase Suspend mode, Data# Polling produces a “1” on DQ7. The system must provide an address within any of the sectors selected for erasure to read valid status information on DQ7.

After a sector erase command sequence is written, if a sector selected for erasing are protected, Data# Polling on DQ7 is active for approximately 1 μ s (~256 μ s for chip erase when all sectors are protected), then the device returns to the read mode. For a chip erase command, if not all selected sectors are protected, the Embedded Erase algorithm erases the unprotected sectors, and ignores the selected sectors that are protected. However, if the system reads DQ7 at an address within a protected sector, the status may not be valid.

Just prior to the completion of an Embedded Program or Erase operation, DQ7 may change asynchronously with DQ6-DQ0 while Output Enable (OE#) is asserted low. That is, the device may change from providing status information to valid data on DQ7. Depending on when the system samples the DQ7 output, it may read the status or valid data. Even if the device has completed the program or erase operation and DQ7 has valid data, the data outputs on DQ6-DQ0 may be still invalid. Valid data on DQ7-DQ0 appears on successive read cycles.

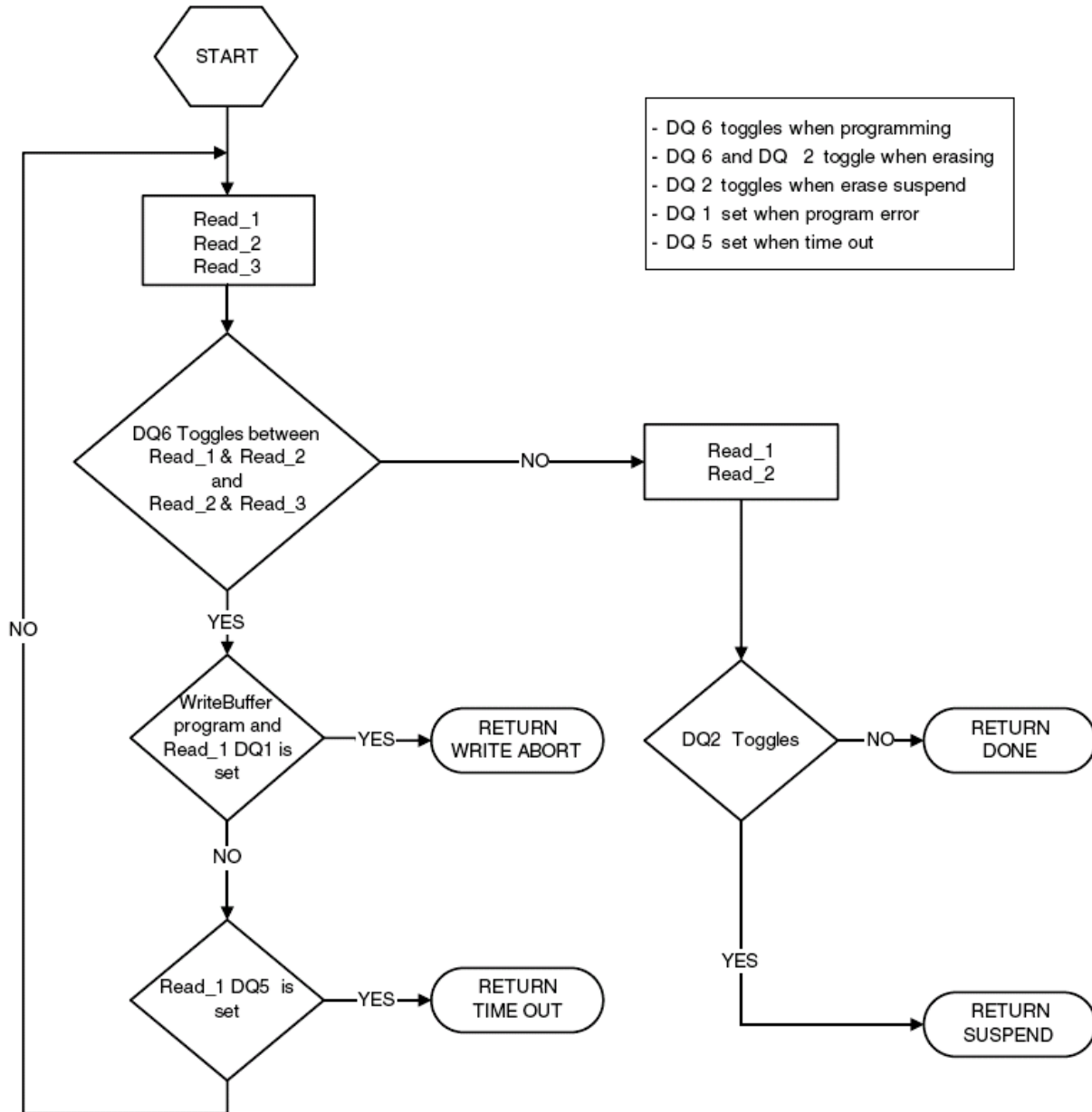
Figure 7. Write Operation Status Flowchart

DQ6: Toggle Bit I

Toggle Bit I on DQ6 indicates whether an Embedded Program or Erase algorithm is in progress or complete, or whether the device has entered the Erase Suspend mode. Toggle Bit I may be read at any address, and is valid after the rising edge of the final WE# pulse in the command sequence (prior to the program or erase operation), and during the sector erase time-out.

During an Embedded Program or Erase algorithm operation, successive read cycles to any address that is being programmed or erased causes DQ6 to toggle. When the operation is complete, DQ6 stops toggling.

After a sector erase command sequence is written, if a sector selected for erasing are protected, DQ6 toggles for approximately 1 μ s, then the device returns to the read mode. For a chip erase command, if not all sectors are protected, the Embedded Erase algorithm erases the unprotected sectors, and ignores the selected sectors that are protected.

The system can use DQ6 and DQ2 together to determine whether a sector is actively erasing or is erase suspended. When the device is actively erasing (that is, the Embedded Erase algorithm is in progress), DQ6 toggles. When the device enters the Erase Suspend mode, DQ6 stops toggling. However, the system must also use DQ2 to determine which sectors are erasing or erase-suspended. Alternatively, the system can use DQ7.

If a program address falls within a protected sector, DQ6 toggles for approximately 1 μ s after the program command sequence is written, then returns to reading array data. DQ6 also toggles during the erase-suspend-program mode, and stops toggling once the Embedded Program Algorithm is complete.

Toggle Bit I on DQ6 requires either OE# or CE# to be de-asserted and reasserted to show the change in state.

DQ2: Toggle Bit II

The “Toggle Bit II” on DQ2, when used with DQ6, indicates whether a particular sector is actively erasing (that is, the Embedded Erase algorithm is in progress), or whether that sector is erase-suspended. Toggle Bit II is valid after the rising edge of the final WE# pulse in the command sequence. DQ2 toggles when the system reads at addresses within those sectors that have been selected for erasure. But DQ2 cannot distinguish whether the sector is actively erasing or is erase-suspended. DQ6, by comparison, indicates whether the device is actively erasing, or is in Erase Suspend, but cannot distinguish which sectors are selected for erasure. Thus, both status bits are required for sector and mode information.

Reading Toggle Bits DQ6/DQ2

Whenever the system initially begins reading toggle bit status, it must read DQ7–DQ0 at least twice in a row to determine whether a toggle bit is toggling. Typically, the system would note and store the value of the toggle bit after the first read. After the second read, the system would compare the new value of the toggle bit with the first. If the toggle bit is not toggling, the device has completed the program or erases operation. The system can read array data on DQ7–DQ0 on the following read cycle. However, if after the initial two read cycles, the system determines that the toggle bit is still toggling, the system also should note whether the value of DQ5 is high. If it is, the system should then determine again whether the toggle bit is toggling, since the toggle bit may have stopped toggling just as DQ5 went high. If the toggle bit is no longer toggling, the device has successfully completed the program or erases operation. If it is still toggling, the device did not complete the operation successfully, and the system must write the reset command to return to reading array data. The remaining scenario is that the system initially determines that the toggle bit is toggling and DQ5 has not gone high. The system may continue to monitor the toggle bit and DQ5 through successive read cycles, determining the status as described in the previous paragraph. Alternatively, it may choose to perform other system tasks. In this case, the system must start at the beginning of the algorithm when it returns to determine the status of the operation.

Note

When verifying the status of a write operation (embedded program/erase) of a memory sector, DQ6 and DQ2 toggle between high and low states in a series of consecutive and contiguous status read cycles. In order for this toggling behavior to be properly observed, the consecutive status bit reads must not be interleaved with read accesses to other memory sectors. If it is not possible to temporarily prevent reads to other memory sectors, then it is recommended to use the DQ7 status bit as the alternative method of determining the active or inactive status of the write operation.

DQ5: Exceeded Timing Limits

DQ5 indicates whether the program or erase time has exceeded a specified internal pulse count limit. Under these conditions DQ5 produces a “1,” indicating that the program or erase cycle was not successfully completed. The device does not output a 1 on DQ5 if the system tries to program a 1 to a location that was previously programmed to 0. Only an erase operation can change a 0 back to a 1. Under this condition, the device ignores the bit that was incorrectly instructed to be programmed from a 0 to a 1, while any other bits that were correctly requested to be changed from 1 to 0 are programmed. Attempting to program a 0 to a 1 is masked during the programming operation. Under valid DQ5 conditions, the system must write the reset command to return to the read mode (or to the erase-suspend-read mode if a sector was previously in the erase-suspend-program mode).

DQ3: Sector Erase Timeout State Indicator

After writing a sector erase command sequence, the output on DQ3 can be checked to determine whether or not an erase operation has begun. (The sector erase timer does not apply to the chip erase command.) When sector erase starts, DQ3 switches from “0” to “1”. This device does not support multiple sector erase (continuous sector erase) command sequences so it is not very meaningful since it immediately shows as a “1” after the first 30h command. Future devices may support this feature.

DQ1: Write to Buffer Abort

DQ1 indicates whether a Write to Buffer operation was aborted. Under these conditions DQ1 produces a “1”. The system must issue the “Write to Buffer Abort Reset” command sequence to return the device to reading array data.

Table 5. Write Operation Status

Status		DQ7 (note 2)	DQ6	DQ5 (note 1)	DQ3	DQ2 (note 2)	DQ1	RY/BY#	
Standard Mode	Embedded Program Algorithm	DQ7#	Toggle	0	N/A	No Toggle	0	0	
	Embedded Erase Algorithm	0	Toggle	0	1	Toggle	N/A	0	
Program Suspend Mode	Program Suspend Read	Program Suspended Sector	Invalid (Not allowed)					1	
		Non-Program Suspended Sector	Data					1	
Erase Suspend Mode	Erase Suspend Read	Erase Suspended Sector	1	No Toggle	0	N/A	Toggle	N/A	1
		Non-Erase Suspended Sector	Data					1	
		Erase Suspend Program (Embedded Program)	DQ7#	Toggle	0	N/A	N/A	N/A	0
Write to Buffer	Busy(note 3)	DQ7#	Toggle	0	N/A	N/A	0	0	
	Abort(note 4)	DQ7#	Toggle	0	N/A	N/A	1	0	

Notes

1. DQ5 switches to 1 when an Embedded Program, Embedded Erase, or Write-to-Buffer operation has exceeded the maximum timing limits.
2. DQ7 and DQ2 require a valid address when reading status information. Refer to the appropriate subsection for further details.
3. The Data# Polling algorithm should be used to monitor the last loaded write-buffer address location.
4. DQ1 switches to 1 when the device has aborted the write-to-buffer operation

Figure 8. Data Polling Flowchart

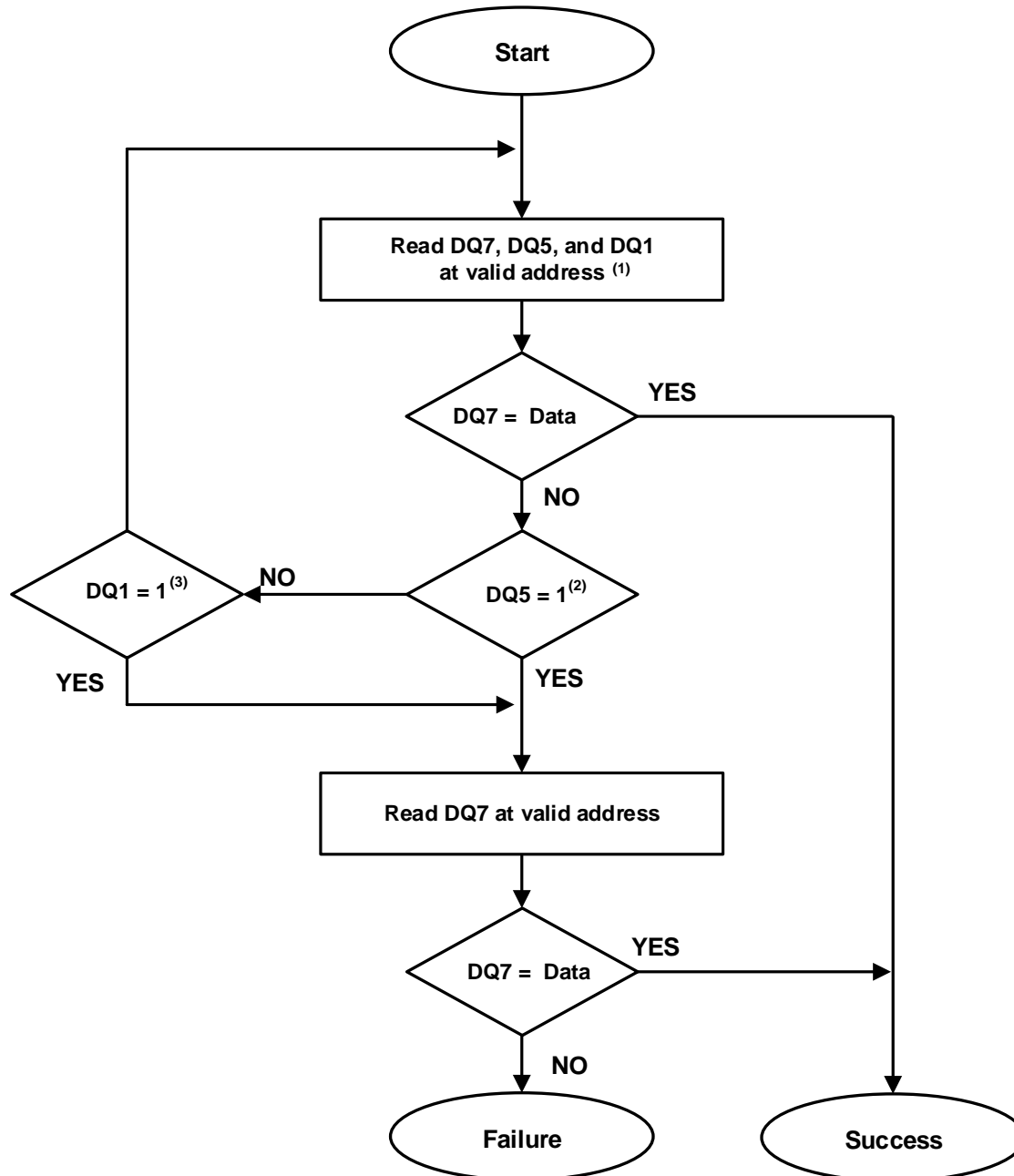
Notes:

1. Valid address is the address being programmed or an address within the block being erased.
2. Failure results: DQ5 = 1 indicates an operation error.
3. DQ1 = 1 indicates a WRITE TO BUFFER PROGRAM ABORT operation.

Writing Commands/Command Sequences

During a write operation, the system must drive CE# and WE# to VIL and OE# to VIH when providing an address, command, and data. Addresses are latched on the last falling edge of WE# or CE#, whichever is last, while data is latched on the 1st rising edge of WE# or CE#, whichever is first. An erase operation can erase one sector or the entire device. Table 3 indicates the address space that each sector occupies. The device address space is divided into uniform 64KW/128KB sectors. A sector address is the set of address bits required to uniquely select a sector. ICC2 in “DC Characteristics” represents the active current specification for the write mode. “AC Characteristics” contains timing specification tables and timing diagrams for write operations.

RY/BY#

The RY/BY# is a dedicated, open-drain output pin that indicates whether an Embedded Algorithm is in progress or complete. The RY/BY# status is valid after the rising edge of the final WE# pulse in the command sequence. Since RY/BY# is an open-drain output, several RY/BY# pins can be tied together in parallel with a pull-up resistor to V_{CC}. This feature allows the host system to detect when data is ready to be read by simply monitoring the RY/BY# pin, which is a dedicated output and controlled by CE# (not OE#).

Hardware Reset

The RESET# input provides a hardware method of resetting the device to reading array data. When RESET# is driven low for at least a period of t_{RP} (RESET# Pulse Width), the device immediately terminates any operation in progress, tri-states all outputs, resets the configuration register, and ignores all read/write commands for the duration of the RESET# pulse. The device also resets the internal state machine to reading array data.

To ensure data integrity Program/Erase operations that were interrupted should be reinitiated once the device is ready to accept another command sequence.

When RESET# is held at VSS, the device draws V_{CC} reset current (ICC5). If RESET# is held at VIL, but not at VSS, the standby current is greater. RESET# may be tied to the system reset circuitry which enables the system to read the boot-up firmware from the Flash memory upon a system reset.

Software Reset

Software reset is part of the command set that also returns the device to array read mode and must be used for the following conditions:

1. To exit from Autoselect or CFI mode back to read mode. It returns back to erase-suspend-read mode if the device was previously in Erase Suspend mode.
2. When DQ5 goes high during write status operation that indicates program or erase cycle was not successfully completed
3. Exit sector lock/unlock operation.
4. After any aborted operations

The following are additional points to consider when using the reset command:

- This command resets the device to read mode and address bits are ignored.
- Reset commands are ignored during program and erase operations.
- The reset command may be written between the cycles in a program command sequence before programming begins (prior to the third cycle). This resets the sector to which the system was writing to the read mode.
- If the program command sequence is written to a sector that is in the Erase Suspend mode, writing the reset command returns that sector to the erase-suspend-read mode.
- The reset command may be written during an Autoselect command sequence.
- If a sector has entered the Autoselect mode while in the Erase Suspend mode, writing the reset command returns that sector to the erase-suspend-read mode.
- If DQ1 goes high during a Write Buffer Programming operation, the system must write the “Write to Buffer Abort Reset” command sequence to RESET the device to reading array data. The standard RESET command does not work during this condition.

Advanced Sector Protection/Unprotection

The Advanced Sector Protection/Unprotection feature disables or enables programming or erase operations, individually, in any or all sectors and can be implemented through software and/or hardware methods, which are independent of each other. This section describes the various methods of protecting data stored in the memory array. An overview of these methods is shown in Figure 9.

Every main flash array sector has a non-volatile (PPB) and a volatile (DYB) protection bit associated with it. When either bit is 0, the sector is protected from program and erase operations.

The PPB bits are protected from program and erase when the PPB Lock bit is 0. There are two methods for managing the state of the PPB Lock bit, Persistent Protection and Password Protection.

The Persistent Protection method sets the PPB Lock to 1 during power up or reset so that the PPB bits are unprotected. There is a command to clear the PPB Lock bit to 0 to protect the PPB bits.

There is no command in the Persistent Protection method to set the PPB Lock bit therefore the PPB Lock bit will remain at 0 until the next power-off or reset. The Persistent Protection method allows boot code the option of changing sector protection by programming or erasing the PPB, then protecting the PPB from further change for the remainder of normal system operation by clearing the PPB Lock bit. This is sometimes called Boot-code controlled sector protection.

The Password method clears the PPB Lock bit to 0 during power up or reset to protect the PPB. A 64-bit password may be permanently programmed and hidden for the password method. A command can be used to provide a password for comparison with the hidden password. If the password matches the PPB Lock bit is set to 1 to unprotect the PPB. A command can be used to clear the PPB Lock bit to 0.

Figure 9. Advanced Sector Protection/Unprotection

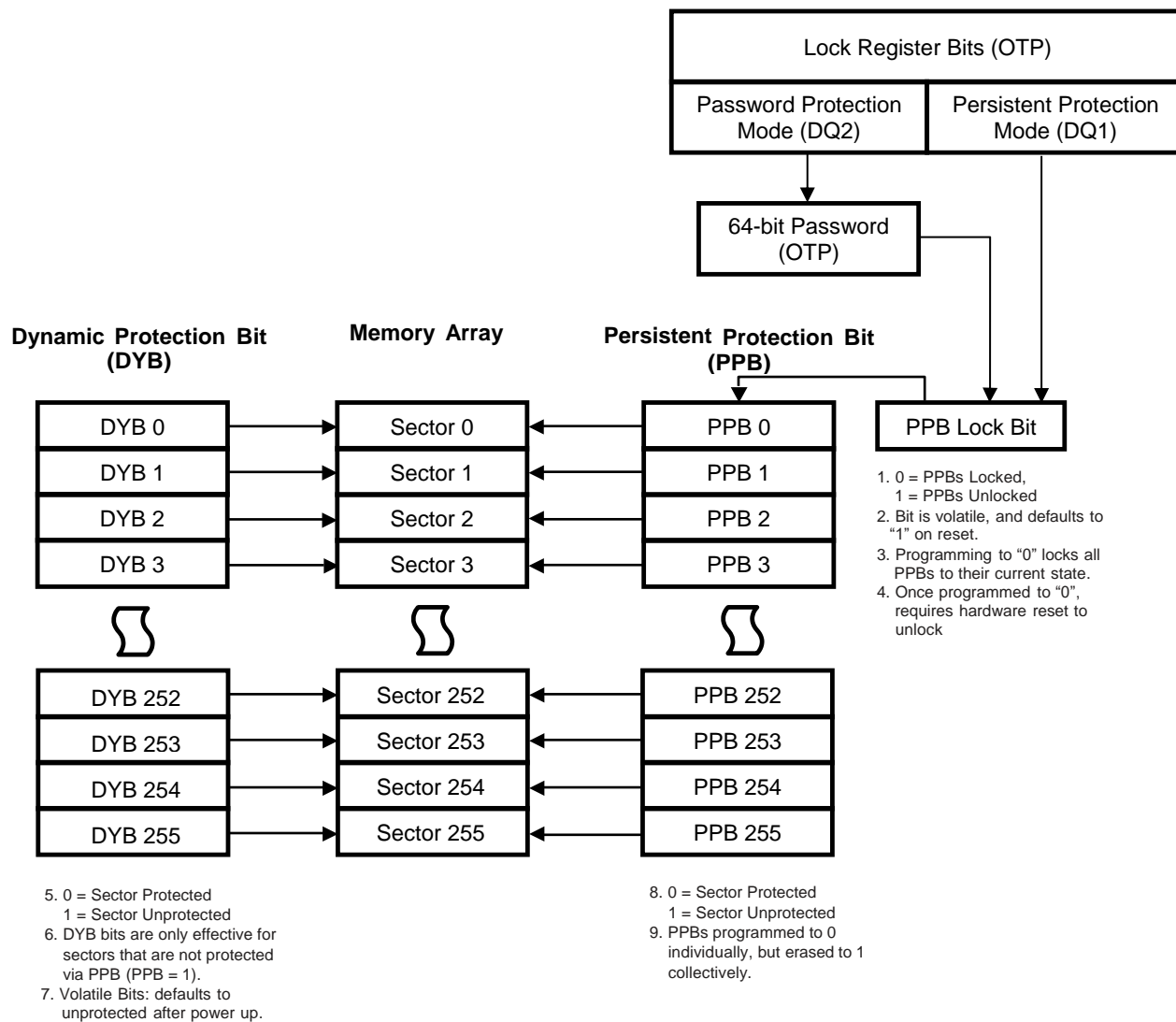

The selection of the PPB Lock management method is made by programming OTP bits in the Lock Register so as to permanently select the method used.

The Lock Register also contains OTP bits, for protecting the Secured Silicon Region.

The PPB bits are erased so that all main flash array sectors are unprotected when shipped from factory.

The Factory Locked Secured Silicon Region is always factory locked when shipped from the factory.

Lock Register

The Lock Register consists of 16 bits and each of these bits in the lock register are non-volatile OTP. The Factory Locked Secured Silicon Region Lock Bit is DQ0 and The Customer Locked Secured Silicon Region Lock Bit is DQ6.

DQ0 is always '0', and it means that the Factory Secured Silicon Region is always locked when shipped from the factory.

If DQ6 is '0', it means that the Customer Locked Secured Silicon Region is locked and if DQ6 is '1', it means that it is unlocked. The Customer Locked Secure Silicon Region Lock Bit must be used with caution, as once locked, there is no procedure available for unlocking the protected portion of the Secure Silicon Region and none of the bits in the protected Secure Silicon Region memory space can be modified in any way. Once Customer Locked Secure Silicon Region area is locked, any further attempts to program in the area will fail.

The Persistent Protection Mode Lock Bit is DQ1 and the Password Protection Mode Lock Bit is DQ2. If DQ1 is set to '0', the device is used in the Persistent Protection Mode. If DQ2 is set to '0', the device is used in the Password Protection Mode. When shipped from the factory, all devices default to the Persistent Protection method. Either DQ1 or DQ2 can be programmed by user. Once programming one of them another one will be permanently disabled and any change is not allowed. If both DQ1 and DQ2 are selected to be programmed at the same time, the operation will abort.

PPB Protection OTP bit is DQ3 and DYB Lock Boot Bit is DQ4. DQ3 is programmed in the ISSI factory. When the device is programmed to disable all PPB erase command, DQ3 outputs a '0' when the lock register bits are read. Similarly, if the device is programmed to enable all PPB erase command, DQ3 outputs a '1' when the lock register bits are read. Likewise the DQ4 bit is also programmed in the ISSI Factory. DQ4 is the bit which indicates whether Volatile Sector Protection Bit (DYB) is protected or not after boot-up. When the device is programmed to set all Volatile Sector Protection Bit protected after power-up, DQ4 outputs a '0' when the lock register bits are read. Similarly, when the device is programmed to set all Volatile Sector Protection Bit unprotected after power-up, DQ4 outputs a '1'. DQ5 and DQ15 ~ DQ7 are reserved and will be 1's.

Table 6. Lock Register

Bit	Default	Description
DQ15 ~ DQ7	Each Bit = 1	Reserved
DQ6	1	Customer Locked Secured Silicon Region Lock Bit (0 = locked, 1 = unlocked)
DQ5	1	Reserved
DQ4	1	DYB Lock Boot Bit 0 = protected all DYB after boot-up 1 = unprotected all DYB after boot-up
DQ3	1	PPB One Time Programmable Bit 0 = All PPB Erase Command disabled 1 = All PPB Erase Command enabled
DQ2	1	Password Protection Mode Lock Bit
DQ1	1	Persistent Protection Mode Lock Bit
DQ0	0	Factory Locked Secured Silicon Region Lock Bit (0 = locked, always locked from factory)

Notes:

1. If the password mode is chosen, the password must be programmed before setting the corresponding lock register bit.
2. After the Lock Register Bits Command Set Entry command sequence is written, reads and writes for Sector 0 are disabled, while reads from other sectors are allowed until exiting this mode.
3. After selecting a sector protection method, each sector can operate in any of the following three states:
 - Constantly locked: The selected sectors are protected and cannot be reprogrammed unless PPB lock bit is cleared via hardware reset, or power cycle.
 - Dynamically locked: The selected sectors are protected but can be unprotected via software commands.
 - Unlocked: The sectors are unprotected and can be erased and/or programmed.

Persistent Protection Bits

The Persistent Protection Bits are unique for each sector and nonvolatile (refer to Figure 9 and Table 3. Sector / Persistent Protection Sector Group Address Tables). It has the same endurance as the Flash memory. Preprogramming and verification prior to erasure are handled by the device, and therefore do not require system monitoring. There is a command to clear the PPB Lock bit to 0 to protect the PPB. However, there is no command in the Persistent Protection method to set the PPB Lock bit to 1 therefore the PPB Lock bit will remain at 0 until the next power up or reset.

Notes

1. Each PPB is individually programmed and all are erased in parallel.
2. While programming PPB and data polling on programming PPB address, array data cannot be read from any sectors.
3. Entry command disables reads and writes for all sectors.
4. Reads within that sector return the PPB status for that sector.
5. If the PPB Lock Bit is set, the PPB Program or erase command does not execute and times-out without programming or erasing the PPB.
6. There are no means for individually erasing a specific PPB and no specific sector address is required for this operation.
7. Exit command must be issued after the execution which resets the device to read mode and re-enables reads and writes for all sectors.
8. The programming state of the PPB for given sectors can be verified by writing a PPB Status Read Command to the device as described by the flow chart shown in Figure 10.1. User only can use DQ6 and RY/BY# pin to detect programming status.

Figure 10.1 PPB Program/Erase Algorithm

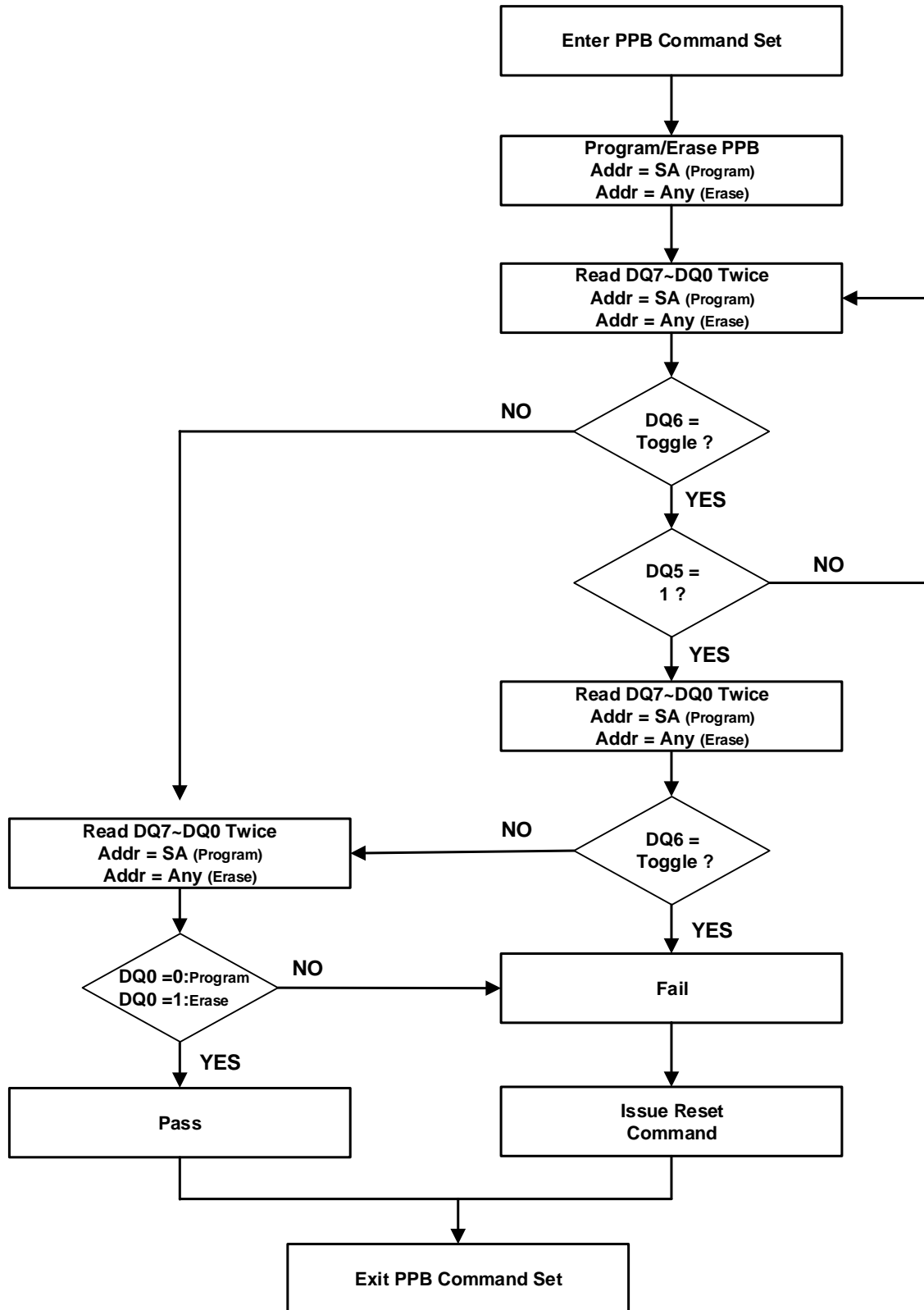

Dynamic Protection Bits

Dynamic Protection Bits are volatile and unique for each sector and can be individually modified. DYBs only control the protection scheme for unprotected sectors that have their PPBs erased to “1”. By issuing the DYB Set or Clear command sequences, the DYBs are set to “0” or cleared to “1”, thus placing each sector in the protected or unprotected state respectively. This feature allows software to easily protect sectors against inadvertent changes yet does not prevent the easy removal of protection when changes are needed.

Notes

1. The DYBs can be set to “0” or cleared to “1” as often as needed. When the parts are first shipped from the factory, the all DYBs are set to “1”. Upon power up or reset, the all DYBs can be set to “0” or cleared to “1”, depending on the setting of DQ4 bit (DYB LOCK Boot Bit) in Lock Register (Table 6).
2. If all DYBs are cleared to “1” after power up, then the sectors may be modified if PPB of that sector is also cleared to “1” (see Table 7).
3. It is possible to have sectors that are persistently locked with sectors that are left in the dynamic state.
4. The DYB Set or Clear commands for the dynamic sectors signify protected or unprotected state of the sectors respectively. However, if there is a need to change the status of the persistently locked sectors, a few more steps are required. First, the PPB Lock Bit must be cleared by either putting the device through a power-cycle, or hardware reset. The PPBs can then be changed to reflect the desired settings. Setting the PPB Lock Bit once again locks the PPBs, and the device operates normally again.
5. To achieve the best protection, it is recommended to execute the PPB Lock Bit Set command early in the boot code and protect the boot code by holding $WP\#/ACC = V_{IL}$.
Note that the PPB and DYB bits have the same function when $WP\#/ACC = V_{HH}$ as they do when $WP\#/ACC = V_{IH}$.

Figure 10.2. DYB Set-Read, Clear-Read Sequence Example

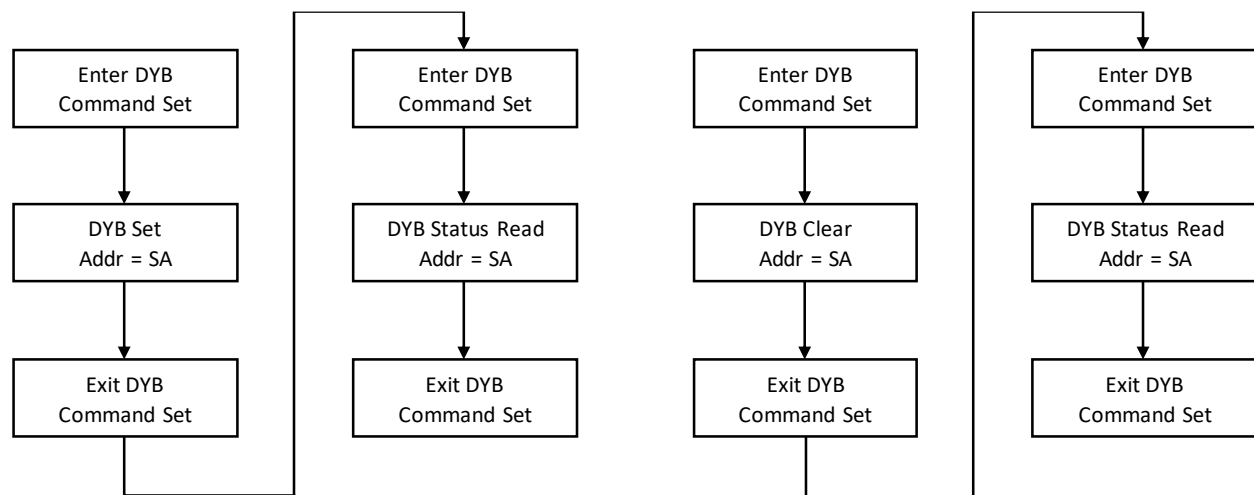

PPB Lock Bit

The Persistent Protection Bit Lock Bit is a global volatile bit for all sectors. When set (programmed to “0”), it locks all PPBs and when cleared (erased to “1”), allows the PPBs to be changed. There is only one PPB Lock Bit per device.

Notes

1. No software command sequence unlocks this bit, but only a hardware reset or a power-up clears this bit.
2. The PPB Lock Bit must be set (programmed to “0”) only after all PPBs are configured to the desired settings.

Password Protection Mode

The Password Protection Mode allows an even higher level of security than the Persistent Sector Protection Mode by requiring a 64-bit password for unlocking the device PPB Lock Bit. In addition to this password requirement, after power up and reset, the PPB Lock Bit is set “0” to maintain the password mode of operation. Successful execution of the Password Unlock command by entering the entire password clears the PPB Lock Bit, allowing for sector PPBs modifications.

Notes

1. The Password Program Command is only capable of programming 0's.
2. The password is all 1's when shipped from factory. It is located in its own memory space and is accessible through the use of the Password Program and Password Read commands.
3. All 64-bit password combinations are valid as a password.
4. Once the Password is programmed and verified, the Password Mode Locking Bit must be set in order to prevent reading or modification of the password.
5. The Password Mode Lock Bit, once programmed, prevents reading the 64-bit password on the data bus and further password programming. All further program and read commands to the password region are disabled (data is read as 1's) and these commands are ignored. There is no means to verify what the password is after the Password Protection Mode Lock Bit is programmed. Password verification is only allowed before selecting the Password Protection mode.
6. The Password Mode Lock Bit is not erasable.
7. The exact password must be entered in order for the unlocking function to occur.
8. The addresses can be loaded in any order but all 4 words are required for a successful match to occur.
9. The Sector Addresses and Word Line Addresses are compared while the password address/data are loaded. If the Sector Address don't match than the error will be reported at the end of that write cycle. It is a failure to change the state of the PPB Lock bit because it is still protected by the lack of a valid password. The data polling status will remain active, with DQ7 set to the complement of the DQ7 bit in the last word of the password unlock command, and DQ6 toggling. RY/BY# will remain low.
10. The device requires approximately 2 μ s for setting the PPB Lock after the valid 64-bit password is given to the device.
11. The Password Unlock command cannot be accepted any faster than once every 2 μ s \pm 0.4 μ s. This helps prevent a hacker from trying all possible 64-bit combinations in an attempt to correctly match a password. The embedded algorithm status checking methods may be used to determine when the device is ready to accept a new password command.
12. If the password is lost after setting the Password Mode Lock Bit, there is no way to clear the PPB Lock.

Figure 11. Lock Register Program Algorithm

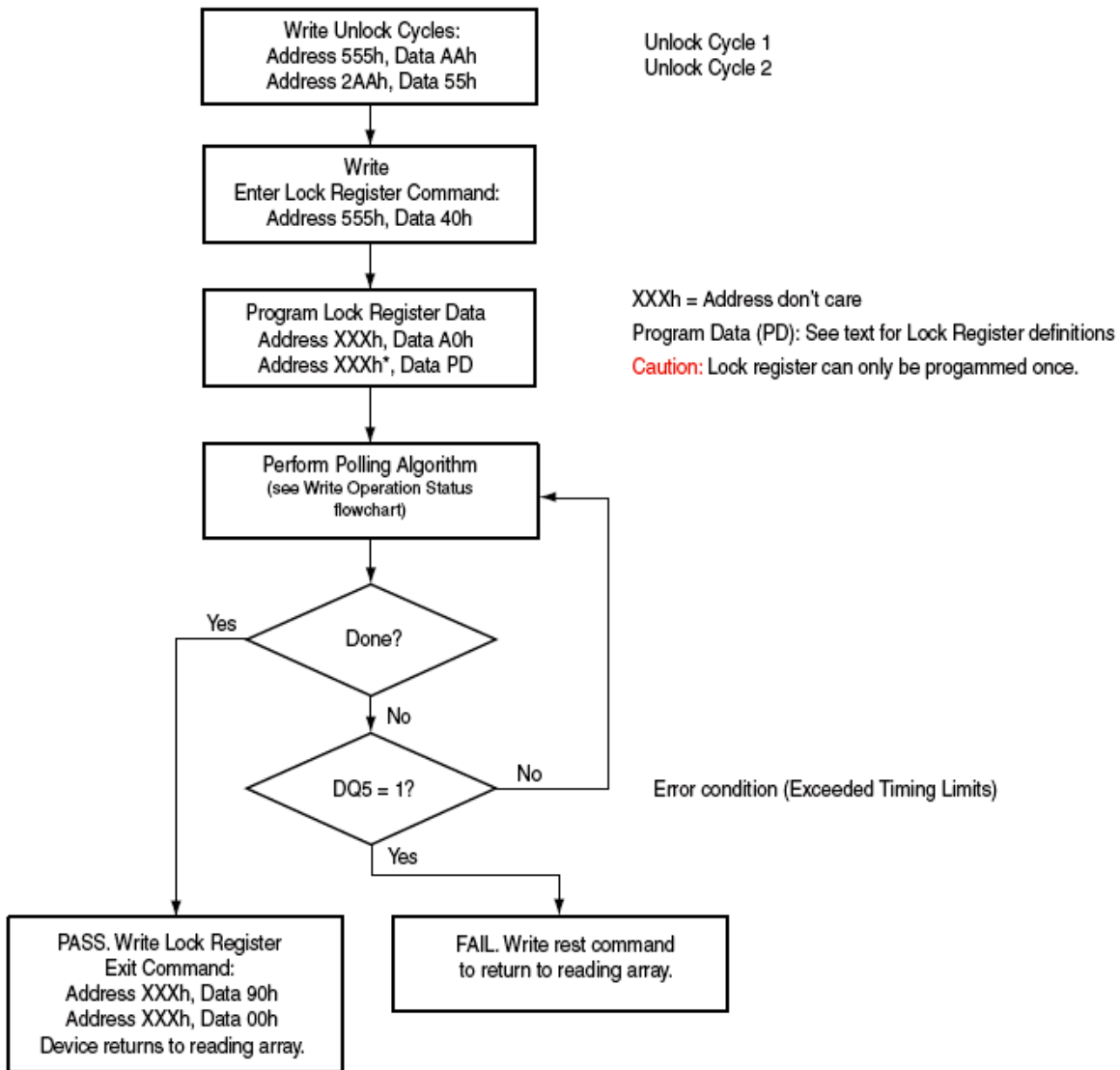

Table 7. Sector Protection Schemes: DYB, PPB and PPB Lock Bit Combinations

Unique Device PPB Lock Bit 0 = locked 1 = unlocked		Sector PPB 0 = protected 1 = unprotected	Sector DYB 0 = protected 1 = unprotected	Sector Protection Status
Any Sector	0	0	x	Protected through PPB
Any Sector	0	0	x	Protected through PPB
Any Sector	0	1	1	Unprotected
Any Sector	0	1	0	Protected through DYB
Any Sector	1	0	x	Protected through PPB
Any Sector	1	0	x	Protected through PPB
Any Sector	1	1	0	Protected through DYB
Any Sector	1	1	1	Unprotected

Table 7 contains all possible combinations of the DYB, PPB, and PPB Lock Bit relating to the status of the sector. In summary, if the PPB Lock Bit is locked (set to “0”), no changes to the PPBs are allowed. The PPB Lock Bit can only be unlocked (reset to “1”) through a hardware reset or power cycle. See also Figure 9 for an overview of the Advanced Sector Protection feature.

Hardware Data Protection Methods

The device offers two main types of data protection at the sector level via hardware control:

- When WP#/ACC is at VIL, the either the highest or lowest sector is locked (device specific).

There are additional methods by which intended or accidental erasure of any sectors can be prevented via hardware means. The following subsections describes these methods:

WP#/ACC Method

The Write Protect feature provides a hardware method of protecting one outermost sector. This function is provided by the WP#/ACC pin and overrides the previously discussed Sector Protection/Unprotection method.

If the system asserts VIL on the WP#/ACC pin, the device disables program and erase functions in the highest or lowest sector independently of whether the sector was protected or unprotected using the method described in Advanced Sector Protection/Unprotection on page 24.

If the system asserts VIH on the WP#/ACC pin, the device reverts to whether the boot sectors were last set to be protected or unprotected. That is, sector protection or unprotection for these sectors depends on whether they were last protected or unprotected.

The WP#/ACC pin must be held stable during a command sequence execution. WP# has a resistive pullup controlled by a latch, which is reset to the VIH state during Vcc power up; when unconnected, WP# will remain at VIH.

Low V_{CC} Write Inhibit

When V_{CC} is less than VLKO (Lock-Out Voltage), the device does not accept any write cycles. This protects data during V_{CC} power-up and power-down.

The command register and all internal program/erase circuits are disabled, and the device resets to reading array data. Subsequent writes are ignored until V_{CC} is greater than VLKO. The system must provide the proper signals to the control inputs to prevent unintentional writes when V_{CC} is greater than VLKO.

Write Pulse “Glitch Protection”

Noise pulses of less than 5 ns (typical) on OE#, CE# or WE# do not initiate a write cycle.

Power-Up Write Inhibit

If WE# = CE# = RESET# = VIL and OE# = VIH during power up, the device does not accept commands on the rising edge of WE#. The internal state machine is automatically reset to the read mode on power-up.

Power Conservation Modes

Standby Mode

When the system is not reading or writing to the device, it can place the device in the standby mode. In this mode, current consumption is greatly reduced, and the outputs are placed in the high impedance state, independent of the OE# input. The device enters the CMOS standby mode when the CE# and RESET# inputs are both held at V_{CC} ± 0.3 V. The device requires standard access time (t_{CE}) for read access, before it is ready to read data. If the device is deselected during erasure or programming, the device draws active current until the operation is completed. ICC4 in “DC Characteristics” represents the standby current specification

Automatic Sleep Mode

The automatic sleep mode minimizes Flash device energy consumption. The device automatically enables this mode when addresses remain stable for t_{ACC} + 30 ns. The automatic sleep mode is independent of the CE#, WE#, and OE# control signals. Standard address access timings provide new data when addresses are changed. While in sleep mode, output data is latched and always available to the system.

Hardware RESET# Input Operation

The RESET# input provides a hardware method of resetting the device to reading array data. When RESET# is driven low for at least a period of t_{RP}, the device immediately terminates any operation in progress, tristates all outputs, and ignores all read/write commands for the duration of the RESET# pulse. The device also resets the internal state machine to reading array data. The operation that was interrupted should be reinitiated once the device is ready to accept another command sequence to ensure data integrity.

When RESET# is held at V_{SS} ± 0.3 V, the device draws ICC reset current (ICC5). If RESET# is held at VIL but not within V_{SS} ± 0.3 V, the standby current is greater.

RESET# may be tied to the system reset circuitry and thus, a system reset would also reset the Flash memory, enabling the system to read the boot-up firmware from the Flash memory.

Output Disable (OE#)

When the OE# input is at VIH, output from the device is disabled. The outputs are placed in the high impedance state. (With the exception of RY/BY#.)

Secured Silicon Region

The Secured Silicon Region provides an extra Flash memory OTP area that can be programmed only once and permanently protected from further changes. The Secured Silicon Region is 1024 bytes in length and consists of 512-byte for Factory Locked Secured Silicon Region, 512-byte for Customer Locked Secured Silicon Region.

Table 8. Secured Silicon Region Assignment

Word Address Range	Content	Size
0000000h ~ 00000FFh	Factory Locked Secured Silicon Region	512 bytes
0000100h ~ 00001FFh	Customer Locked Secured Silicon Region	512 bytes

The Secured Silicon Region Indicator Bits DQ15-DQ0 at Autoselect address 03h is used to indicate whether the Secured Silicon Region is factory locked and customer locked/unlock as well as the lowest or highest address sector WP# protected as the following.

Secured Silicon Region Indicator Bits

Secured Silicon Region Indicator Bits	Description	Data (b = binary)
DQ15 ~ DQ8	Reserved	Each bit = 1
DQ7	Factory Locked Secured Silicon Region	1 = Locked (always 1)
DQ6	Customer Locked Secured Silicon Region	0 = Unlocked 1 = Locked
DQ5	Reserved	1b
DQ4	WP# Protects	0 = Lowest Address Sector 1 = Highest Address Sector
DQ3 ~ DQ0	Reserved	1111b

Please note the following general conditions:

- On power-up, or following a hardware reset, the device reverts to sending commands to the normal address space.
- Reads outside of sector SA0 return invalid data. Reads locations above 1-Kbyte address of the sector SA0 return invalid data.
- Sector SA0 during the Secured Silicon Sector Entry Command is remapped from memory array to Secured Silicon Sector array.
- Once the Secured Silicon Sector Entry Command is issued, the Secured Silicon Sector Exit command must be issued to exit Secured Silicon Sector Mode.
- The Secured Silicon Sector is not accessible when the device is executing an Embedded Program or Embedded Erase algorithm.
- Regardless that the sector SA0 is suspended, if system enters Secured Silicon Sector mode, the Secured Silicon Sector Region can be read.
- The ACC function is not available when the Secured Silicon Sector is enabled.

Factory Locked Secured Silicon Region

The Factory Locked Secured Silicon Region is always programmed and locked in the ISSI factory. Factory Locked Secured Silicon Region Indicator Bit DQ7 is always “1” and Factory Locked Secured Silicon Region Lock Bit DQ0 of the Lock Register is always “0” from the factory.

Customer Locked Secured Silicon Region

The Customer Locked Secured Silicon Region is always unprotected when shipped from the factory (Customer Locked Secured Silicon Region Indicator Bit DQ6 set to “0”), allowing customers to utilize that sector in any manner they choose.

Please note the following:

- The Secured Silicon Region can be read any number of times, but can be programmed and locked only once. The Customer Locked Secured Silicon Region must be locked with caution, as once locked, there is no procedure available for unlocking the Customer Locked Secured Silicon Region and none of the bits in the Customer Locked Secured Silicon Sector memory space can be modified in any way.
- The accelerated programming (ACC) is not available when the Secured Silicon Region is enabled.
- Once the Secured Silicon Region is locked and verified, the system must write the Exit Secured Silicon Region command sequence which return the device to the memory array at sector 0.

Secured Silicon Region Entry/Exit Command Sequences

The system can access the Secured Silicon Region by issuing the three-cycle Enter Secured Silicon Region command sequence. The device continues to access the Secured Silicon Region until the system issues the four-cycle Exit Secured Silicon Region command sequence.

The Secured Silicon Region Entry Command allows the following commands to be executed

- Read Customer Locked Secured Silicon Region and Factory Locked Secured Silicon Region
- Program the Customer Locked Secured Silicon Region

After the system has written the Enter Secured Silicon Region command sequence, it may read the Secured Silicon Region by using the addresses normally occupied by sector SA0 within the memory array. This mode of operation continues until the system issues the Exit Secured Silicon Region command sequence, or until power is removed from the device.

COMMON FLASH INTERFACE (CFI)

The common flash interface (CFI) specification outlines device and host systems software interrogation handshake, which allows specific vendor-specified software algorithms to be used for entire families of devices. Software support can then be device-independent, JEDEC ID-independent, and forward- and backward-compatible for the specified flash device families. Flash vendors can standardize their existing interfaces for long-term compatibility.

This device enters the CFI Query mode when the system writes the CFI Query command, 98h, to address 55h in word mode (or address AAh in byte mode), any time the device is ready to read array data.

The system can read CFI information at the addresses given in Tables 9~12. In word mode, the upper address bits (A7–MSB) must be all zeros. To terminate reading CFI data, the system must write the reset command.

The system can also write the CFI query command when the device is in the Autoselect mode. The device enters the CFI query mode and the system can read CFI data at the addresses given in Tables 9~12. The system must write the reset command to return the device to the Autoselect mode.

Table 9. CFI Query Identification String

Addresses (Word Mode)	Data	Description
10h 11h 12h	0051h 0052h 0059h	Query Unique ASCII string "QRY"
13h 14h	0002h 0000h	Primary OEM Command Set
15h 16h	0040h 0000h	Address for Primary Extended Table
17h 18h	0000h 0000h	Alternate OEM Command set (00h = none exists)
19h 1Ah	0000h 0000h	Address for Alternate OEM Extended Table (00h = none exists)

Table 10. System Interface String

Addresses (Word Mode)	Data	Description
1Bh	0027h	Vcc Min (write/erase) DQ7-DQ4: volt, DQ3-DQ0: 100mV
1Ch	0036h	Vcc Max (write/erase) DQ7-DQ4: volt, DQ3-DQ0: 100mV
1Dh	0000h	Vpp Min voltage (00h = no Vpp pin present)
1Eh	0000h	Vpp Max voltage (00h = no Vpp pin present)
1Fh	0003h	Typical timeout per single byte/word write 2^N μ s
20h	0008h	Typical timeout for min size buffer write 2^N μ s (00h = not supported)
21h	0008h	Typical timeout per individual block erase 2^N ms
22h	0010h(256Mb) 000Fh(128Mb)	Typical timeout for full chip erase 2^N ms (00h = not supported)
23h	0005h	Max timeout for byte/word write 2^N times typical
24h	0002h	Max timeout for buffer write 2^N times typical
25h	0004h	Max timeout per individual block erase 2^N times typical
26h	0003h	Max timeout for full chip erase 2^N times typical (00h = not supported)

Table 11. Device Geometry Definition

Addresses (Word mode)	Data	Description
27h	0019h 0018h	Device Size = 2 ^N bytes. 0019h for 256Mb, 0018h for 128Mb
28h 29h	0002h 0000h	Flash Device Interface Description (refer to CFI publication 100); 01h = X16 only; 02h = x8/x16
2Ah 2Bh	0006h 0000h	Max number of byte in multi-byte write = 2 ^N (00h = not supported)
2Ch	0001h	Number of Erase Block Regions within device
2Dh 2Eh 2Fh 30h	00XXh 0000h 0000h 0002h	Erase Block Region 1 Information (refer to the CFI specification of CFI publication 100) 00FFh, 000h, 000h, 0002h = 256Mb 007Fh, 000h, 000h, 0002h = 128Mb
31h 32h 33h 34h	0000h 0000h 0000h 0000h	Erase Block Region 2 Information (refer to the CFI specification of CFI publication 100)
35h 36h 37h 38h	0000h 0000h 0000h 0000h	Erase Block Region 3 Information (refer to the CFI specification of CFI publication 100)
39h 3Ah 3Bh 3Ch	0000h 0000h 0000h 0000h	Erase Block Region 4 Information (refer to the CFI specification of CFI publication 100)

Table 12. Primary Vendor-specific Extended Query

Addresses (Word Mode)	Data	Description
40h 41h 42h	0050h 0052h 0049h	Query Unique ASCII string "PRI"
43h	0031h	Major version number, ASCII
44h	0034h	Minor version number, ASCII
45h	0010h	Address Sensitive Unlock (Bits 1-0) 00 = Required, 01 = Not Required Process Technology (Bits 5-2) 0001 = 0.18um, 0010 = 0.13um, 0011 = 90nm, 0100 = 65nm
46h	0002h	Erase Suspend 0 = Not Supported, 1 = To Read Only, 2 = To Read & Write
47h	0001h	Sector Protect 0 = Not Supported, X = Minimum number of sectors per group
48h	0000h	Sector Temporary Unprotect 00 = Not Supported, 01 = Supported
49h	0004h	Sector Protect/Unprotect Scheme 00h = High Voltage Sector Protection 01h = High Voltage + In-System Sector Protection 02h = HV + In-System + Software Command Sector Protection 03h = Software Command Sector Protection 04h = Advanced Sector Protection Method
4Ah	0000h	Simultaneous Operation 00 = Not Supported, X = Number of Sectors
4Bh	0000h	Burst Mode Type 00 = Not Supported, 01 = Supported
4Ch	0002h	Page Mode Type 00 = Not Supported, 01 = 4 Word Page, 02 = 8 Word Page 03 = 16 Word Page
4Dh	0085h	Minimum WP#/ACC (Acceleration) Supply Voltage 00 = Not Supported, DQ7-DQ4: Volts, DQ3=DQ0: 100mV
4Eh	0095h	Maximum WP#/ACC (Acceleration) Supply Voltage 00 = Not Supported, DQ7-DQ4: Volts, DQ3=DQ0: 100mV
4Fh	00xxh	Top/Bottom Boot Sector Flag 04 = Uniform sectors bottom WP# protect 05 = Uniform sectors top WP# protect
50h	0001h	Program Suspend 00 = Not Supported, 01 = Supported
51h	0000h	Unlock Bypass 00 = Not Supported, 01 = Supported
52h	0009h	Secured Silicon Region (Customer OTP Area) Size 2 ^N bytes
53h	000Fh	Hardware Reset Low Time-out during an embedded algorithm to read mode Maximum 2 ^N ns
54h	0009h	Hardware Reset Low Time-out not during an embedded algorithm to read mode Maximum 2 ^N ns
55h	0005h	Erase Suspend Latency Maximum 2 ^N μs
56h	0005h	Program Suspend Latency Maximum 2 ^N μs
57h	0000h	Bank Organization 00 = Data at 4Ah is zero, X = Number of Banks

Table 13. IS29GL256/128 Command Definitions

Command Sequence			Cycles	Bus Cycles												
				1 st Cycle		2 nd Cycle		3 rd Cycle		4 th Cycle		5 th Cycle		6 th Cycle		
				Addr	Data	Addr	Data	Addr	Data	Addr	Data	Addr	Data	Addr	Data	
Read			1	RA	RD											
Reset			1	XXX	F0											
Autoselect	Manufacturer ID	Word	4	555	AA	2AA	55	555	90	X00	9D					
		Byte	4	AAA	AA	555	55	AAA	90	X00	9D					
	Device ID	256Mb	Word	4	555	AA	2AA	55	555	90	X01	227E	X0E	2222	X0F	2201
			Byte	4	AAA	AA	555	55	AAA	90	X02	7E	X1C	22	X1E	01
		128Mb	Word	4	555	AA	2AA	55	555	90	X01	227E	X0E	2221	X0F	2201
			Byte	4	AAA	AA	555	55	AAA	90	X02	7E	X1C	21	X1E	01
	Sector Protect Verify ⁽¹⁾		Word	4	555	AA	2AA	55	555	90	(SA) X02	00 01				
			Byte	4	AAA	AA	555	55	AAA	90	(SA) X04	00 01				
	Program		Word	4	555	AA	2AA	55	555	A0	PA	PD				
			Byte	4	AAA	AA	555	55	AAA	A0	PA	PD				
Write to Buffer		Word	6	555	AA	2AA	55	SA	25	SA	WC	PA	PD	WBL	PD	
		Byte	6	AAA	AA	555	55	SA	25	SA	WC	PA	PD	WBL	PD	
Program Buffer to Flash		Word	1	SA	29											
		Byte	1	SA	29											
Write to Buffer Abort Reset		Word	3	555	AA	2AA	55	555	F0							
		Byte	3	AAA	AA	555	55	AAA	F0							
Chip Erase		Word	6	555	AA	2AA	55	555	80	555	AA	2AA	55	555	10	
		Byte	6	AAA	AA	555	55	AAA	80	AAA	AA	555	55	AAA	10	
Sector Erase		Word	6	555	AA	2AA	55	555	80	555	AA	2AA	55	SA	30	
		Byte	6	AAA	AA	555	55	AAA	80	AAA	AA	555	55	SA	30	
Erase/Program Suspend		Word	1	XXX	B0											
		Byte	1	XXX	B0											
Erase/Program Resume		Word	1	XXX	30											
		Byte	1	XXX	30											
Secured Silicon Region Entry		Word	3	555	AA	2AA	55	555	88							
		Byte	3	AAA	AA	555	55	AAA	88							
Secured Silicon Region Exit		Word	4	555	AA	2AA	55	555	90	XX	00					
		Byte	4	AAA	AA	555	55	AAA	90	XX	00					
CFI Query		Word	1	55	98											
		Byte	1	AA	98											
Accelerated Program			2	XX	A0	PA	PD									

Legend

X = Don't care

RA = Address of the memory to be read.

RD = Data read from location RA during read operation.

PA = Address of the memory location to be programmed. Addresses latch on the falling edge of the WE# or CE# pulse, whichever happens later.

PD = Data to be programmed at location PA. Data latches on the rising edge of the WE# or CE# pulse, whichever happens first.

SA = Address of the sector to be verified (in Autoselect mode) or erased. Address bits Amax–A16 uniquely select any sector.

WBL = Write Buffer Location. The address must be within the same write buffer page as PA.

WC = Word Count is the number of write buffer locations to load minus 1 and maximum value is 31 for word and byte mode.

Note:

1. The data is 00h for an unprotected sector and 01h for a protected sector. This is same as PPB Status Read except that the protect and unprotect statuses are inverted here.

Table 14. IS29GL256/128 Command Definitions

Command Sequence			Cycles	Bus Cycles											
				1 st /7 th Cycle		2 nd Cycle		3 rd Cycle		4 th Cycle		5 th Cycle		6 th Cycle	
				Addr	Data	Addr	Data	Addr	Data	Addr	Data	Addr	Data	Addr	Data
Lock Register	Command Set Entry	Word	3	555	AA	2AA	55	555	40						
		Byte	3	AAA	AA	55	55	AAA	40						
	Program		2	XXX	A0	XXX	Data								
	Read		1	00	RD										
	Command Set Exit		2	XXX	90	XXX	00								
Password Protection	Command Set Entry	Word	3	555	AA	2AA	55	555	60						
		Byte	3	AAA	AA	55	55	AAA	60						
	Password Program ⁽¹⁾		2	XXX	A0	PWAx	PWDx								
	Password Read ⁽²⁾		4	00	PWD0	01	PWD1	02	PWD2	03	PWD3				
	Password Unlock ⁽²⁾		7	00	25	00	03	00	PWD0	01	PWD1	02	PWD2	03	PWD3
			7	00	29										
Command Set Exit		2	XXX	90	XXX	00									
Global Non-Volatile	PPB Command Set Entry	Word	3	555	AA	2AA	55	555	C0						
		Byte	3	AAA	AA	55	55	AAA	C0						
	PPB Program ⁽³⁾		2	XXX	A0	SA ⁽³⁾	00								
	All PPB Erase		2	XXX	80	00	30								
	PPB Status Read		1	SA	RD										
PPB Command Set Exit		2	XXX	90	XXX	00									
Global Volatile Freeze	PPB Lock Command Set Entry	Word	3	555	AA	2AA	55	555	50						
		Byte	3	AAA	AA	555	55	AAA	50						
	PPB Lock Set		2	XXX	A0	XXX	00								
	PPB Lock Status Read		1	XXX	RD										
PPB Lock Command Set Exit		2	XXX	90	XXX	00									
Volatile	DYB Command Set Entry	Word	3	555	AA	2AA	55	555	E0						
		Byte	3	AAA	AA	555	55	AAA	E0						
	DYB Set		2	XXX	A0	SA	00								
	DYB Clear		2	XXX	A0	SA	01								
	DYB Status Read ⁽⁴⁾		1	SA	RD										
DYB Command Set Exit		2	XXX	90	XXX	00									

Legend

X = Don't care
RD(0) = Read data.
SA = Sector Address. Address bits Amax–A16 uniquely select any sector.
PWD = Password
PWDx = Password word0, word1, word2, and word3.
Data = Lock Register Contents: PD(0) = Secured Silicon Region Lock Bit,
PD(1) = Persistent Protection Mode Lock Bit, PD(2) = Password Protection Mode Lock Bit.

Notes:

- Protected State = "00h", Unprotected State = "01h."
1. For PWDx, only one portion of the password can be programmed per each
2. Note that the password portion can be entered or read in any order as long as the entire 64-bit password is entered or read.
3. SA = Sector Address. Address bits Amax–A16 uniquely select any sector, and A-1=0 in x8 mode.
4. DYB Status Read also includes WP#/ACC=L effect.

Table 15. DC Characteristics

(Under recommended operating ranges)

Symbol	Parameter	Test Conditions	Min	Typ ⁽⁴⁾	Max	Unit
I _{LI}	Input Leakage Current	$0V \leq V_{IN} \leq V_{CC}$			±1	μA
I _{LO}	Output Leakage Current	$0V \leq V_{OUT} \leq V_{CC}$			±1	μA
I _{CC1} ⁽²⁾	V _{CC} Active Read Current	CE# = V _{IL} ; OE# = V _{IH} , V _{CC} = V _{CCmax}	5MHz	15	30	mA
			10MHz	25	45	
I _{IO2}	V _{IO} Non-Active Output	CE# = V _{IL} , OE# = V _{IH} , V _{CC} = V _{CCmax}		0.2	10	mA
I _{CC2} ⁽²⁾	V _{CC} Intra-Page Read Current	CE# = V _{IL} , OE# = V _{IH} , V _{CC} = V _{CCmax} , f = 10 MHz		1	10	mA
				5	15	
I _{CC3} ^{(2),(3)}	V _{CC} Active Erase/ Program Current	CE# = V _{IL} , OE# = V _{IH} , V _{CC} = V _{CCmax}		20	40	mA
I _{CC4} ^{(1),(2)}	V _{CC} Standby Current	CE#, RESET# = V _{CC} ± 0.3 V, OE# = V _{IH} , V _{CC} = V _{CC} max V _{IL} = V _{SS} + 0.3 V/-0.1V,		70	150	μA
I _{CC5} ⁽²⁾	V _{CC} Reset Current	RESET# = V _{SS} ± 0.3V, V _{CC} = V _{CCmax}		70	150	μA
I _{CC6} ^{(1),(2)}	Automatic Sleep Mode	V _{IH} = V _{CC} ± 0.3 V, V _{IL} = V _{SS} ± 0.3V		70	150	μA
I _{ACC}	ACC Accelerated Program Current	CE# = V _{IL} , OE# = V _{IH} , V _{CC} = V _{CCmax} , WP#/ACC = V _{HH}	WP#/ACC pin	3	10	mA
			V _{CC} pin	15	30	
V _{IL}	Input Low Voltage		-0.5		0.3 x V _{IO}	V
V _{IH}	Input High Voltage		0.7 x V _{IO}		V _{IO} + 0.3	V
V _{HH}	Acceleration Program Voltage		8.5		9.5	V
V _{OL}	Output Low Voltage	I _{OL} = 100μA			0.15 x V _{IO}	V
V _{OH}	Output High Voltage CMOS	I _{OH} = -100μA	0.85 x V _{IO}			V
V _{LKO} ⁽³⁾	Supply voltage (Erase and Program lock-out)		2.2		2.5	V

Notes:

1. BYTE# pin can also be GND ± 0.3V. BYTE# and RESET# pin input buffers are always enabled so that they draw power if not at full CMOS supply voltages.
2. Maximum I_{CC} specifications are tested with V_{CC} = V_{CCmax} and V_{IO} = V_{CCmax}.
3. Not 100% tested.
4. Typical values are included for reference only and are not guaranteed or tested. Typical values are measured at V_{CC} = V_{CC} (Typ), V_{IO} = V_{IO} (Typ), and TA=25°C.

Figure 12. Test Conditions

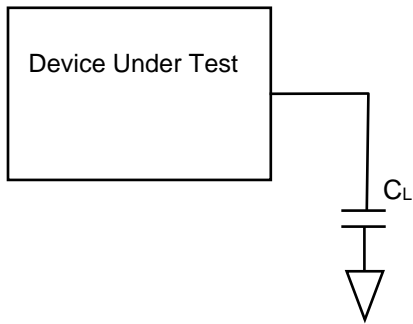

Table 16. Test Specifications

Test Conditions	-	Unit
Output Load Capacitance, C_L	30	pF
Input Rise and Fall times	5	ns
Input Pulse Levels	0.0-V _{IO}	V
Input timing measurement reference levels	0.5V _{IO}	V
Output timing measurement reference levels	0.5V _{IO}	V

AC CHARACTERISTICS

Table 17. Read-only Operations Characteristics

(Under recommended operating ranges)

Parameter Symbols		Description	Test Setup		Speed			Unit
JEDEC	Standard				70ns	80ns	90ns	
tAVAV	tRC	Read Cycle Time		Min	70	80	90	ns
tAVQV	tACC	Address to Output Delay	CE# = V _{IL} OE# = V _{IL}	Max	70	80	90	ns
tELQV	tCE	Chip Enable To Output Delay	OE# = V _{IL}	Max	70	80	90	ns
	tPACC	Page Access Time		Max	20	20	25	ns
tGLQV	tOE	Output Enable to Output Delay	Read	Max	25	25	30	ns
			Toggle and DATA# Polling	Max	35	35	35	ns
tEHQZ ⁽¹⁾	tDF	Chip Enable to Output High Z		Max	15	15	15	ns
tGHQZ ⁽¹⁾	tDF	Output Enable to Output High Z		Max	15	15	15	ns
tAXQX	tOH	Output Hold Time from Addresses, CE# or OE#, whichever occurs first		Min	0	0	0	ns
	tVCS	Vcc Setup Time		Min	50	50	50	μs
	tOEH	Output Enable Hold Time	Read	Min	0	0	0	ns
			Toggle and DATA# Polling	Min	0	0	0	ns

Note:

1. High Z is Not 100% tested.
2. tOE parameter will meet specification value when the interval between CE# LOW and OE# LOW or Valid address to OE# LOW is equal to or longer than (tCE – tOE) or (tACC – tOE).

Figure 13.1 READ to READ Operation Timing Diagram (WE#=HIGH, CE# Toggle)

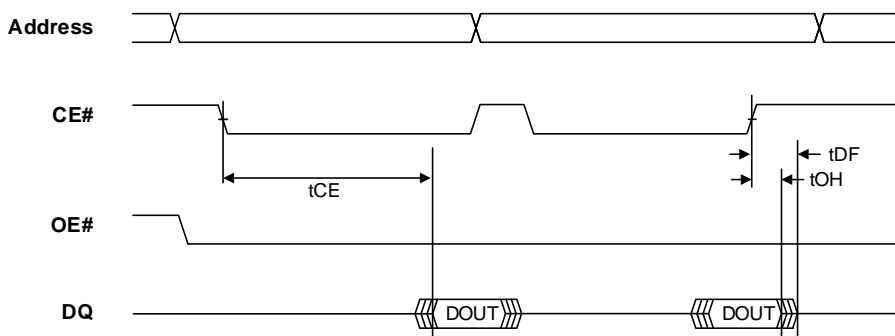

Note:

1. Please [click here](#) to refer to Application Note (AN25D012, Understanding and Interpreting Read Timing of Parallel NOR FLASH).

Figure 13.2. READ to READ Operatio Timing Diagram (OE# Toggle)

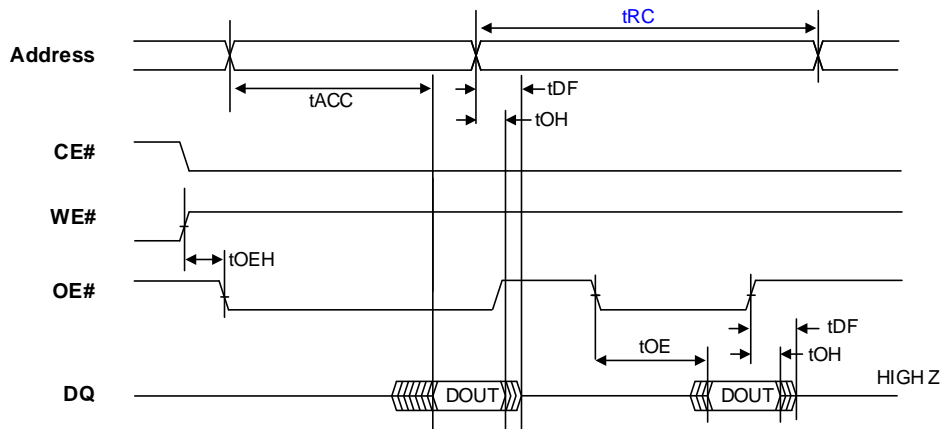
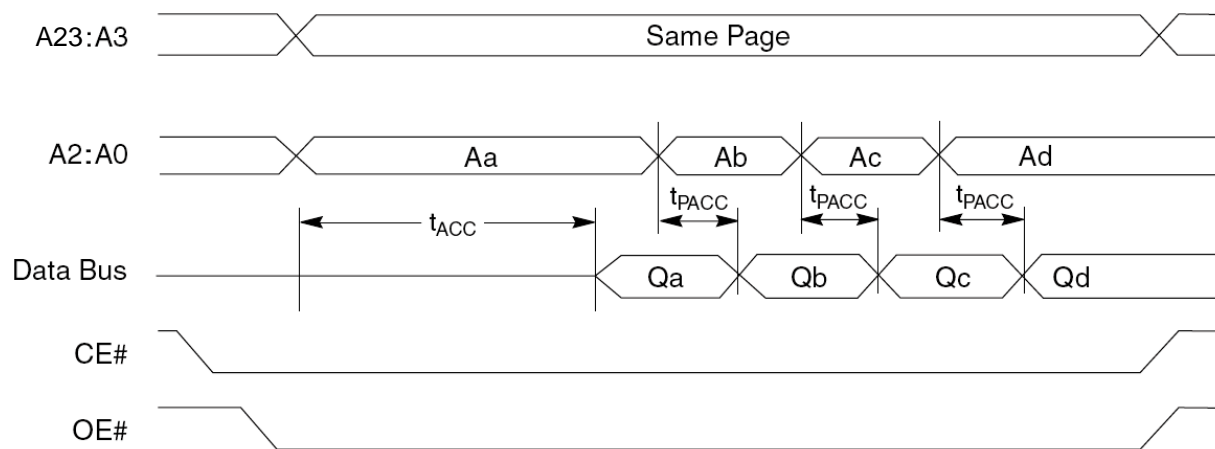

Figure 14. Page Read Operation Timings



Note: Addresses are A2:A-1 for byte mode.

AC CHARACTERISTICS

Table 18. Hardware Reset (RESET#)

(Under recommended operating ranges)

Parameter Std	Description	Test Setup	Speed	Unit
			70/80/90ns	
t_{RP1}	RESET# Pulse Width (During Embedded Algorithms)	Min	200	ns
t_{RP2}	RESET# Pulse Width (NOT During Embedded Algorithms)	Min	200	ns
t_{RH}	Reset# High Time Before Read	Min	50	ns
t_{RB1}	RY/BY# Recovery Time (to CE#, OE# go low)	Min	0	ns
t_{RB2}	RY/BY# Recovery Time (to WE# go low)	Min	50	ns
t_{READY1}	Reset# Pin Low (During Embedded Algorithms) to Read or Write	Max	20	us
t_{READY2}	Reset# Pin Low (NOT During Embedded Algorithms) to Read or Write	Max	500	ns

Figure 15. AC Waveforms for RESET#
Reset# Timings

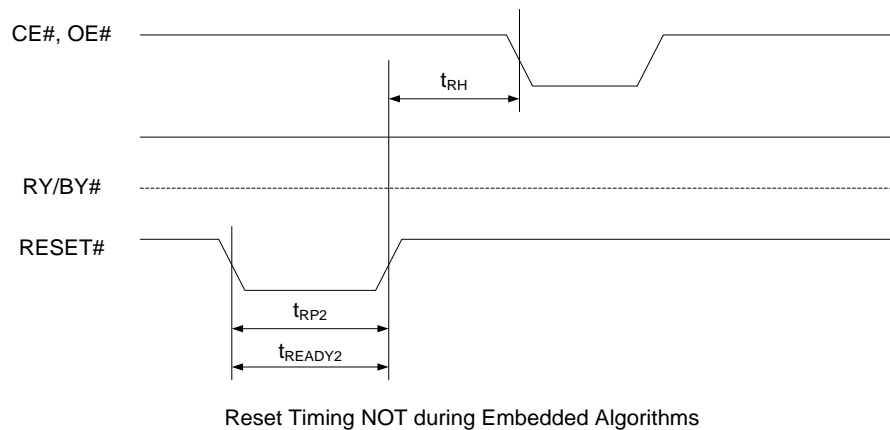
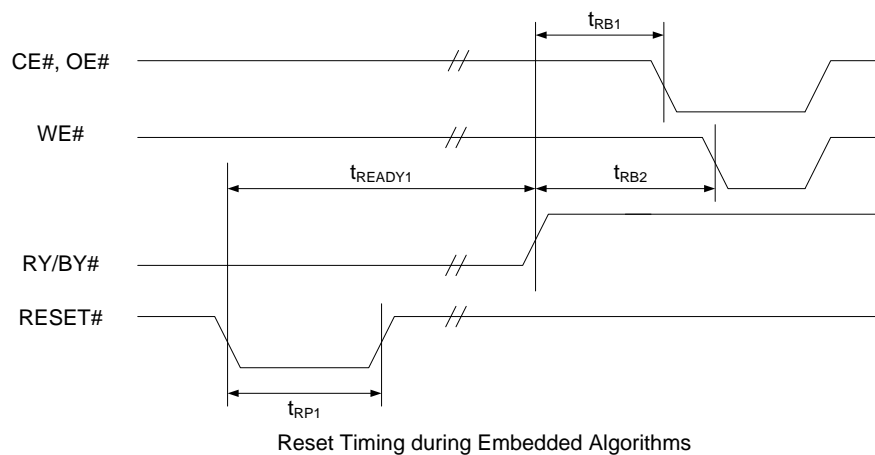

AC CHARACTERISTICS

Table 19. Word / Byte Configuration (BYTE#)

(Under recommended operating ranges)

Std Parameter	Description	Test Setup	Speed	Unit
			70/80/90ns	
t _{BCS}	Byte# to CE# switching setup time	Min	0	ns
t _{CBH}	CE# to Byte# switching hold time	Min	0	ns
t _{RBH}	RY/BY# to Byte# switching hold time	Min	0	ns

Figure 16. AC Waveforms for BYTE#

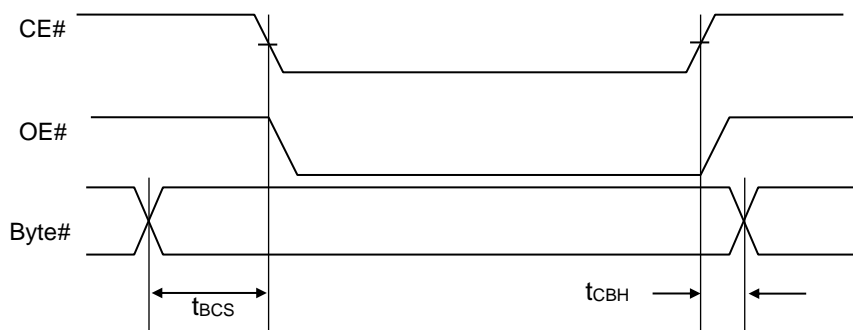

Byte# timings for Read Operations

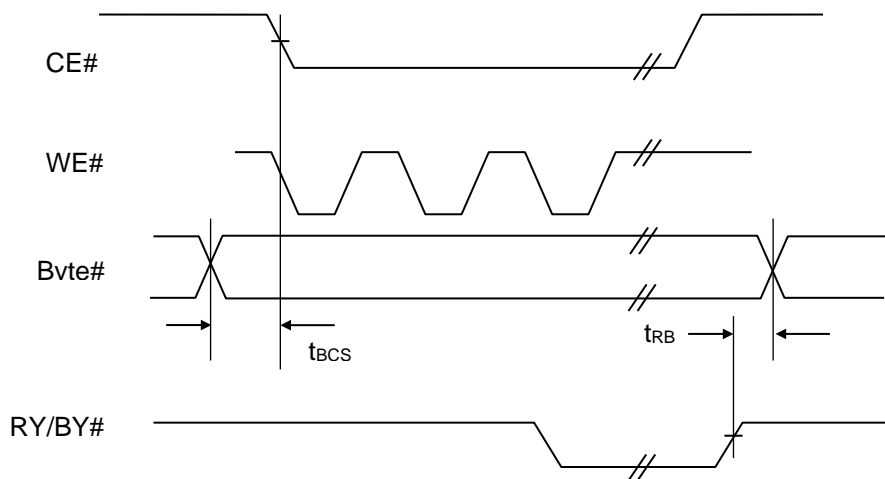

Byte #timings for Write Operations

Note: Switching BYTE# pin not allowed during embedded operations

AC CHARACTERISTICS

Table 20. Write (Erase/Program) Operations

(Under recommended operating ranges)

Parameter Symbols		Description		Speed ⁽¹⁾			Unit	
JEDEC	Standard			70ns	80ns	90ns		
t _{AVAV}	t _{WC}	Write Cycle Time	Min	70	80	90	ns	
t _{AVWL}	t _{AS}	Address Setup Time	Min	0	0	0	ns	
t _{WLAX}	t _{AH}	Address Hold Time	Min	45	45	45	ns	
t _{DVWH}	t _{DS}	Data Setup Time	Min	30	30	30	ns	
t _{WHDX}	t _{DH}	Data Hold Time	Min	0	0	0	ns	
	t _{OEHL}	Output Enable Hold Time	Read	Min	0	0	ns	
			Toggle and DATA# Polling	Min	10	10	10	ns
t _{GHWL}	t _{GHWL}	Read Recovery Time before Write (OE# High to WE# Low)	Min	0	0	0	ns	
t _{ELWL}	t _{CS}	CE# Setup Time	Min	0	0	0	ns	
t _{WHEH}	t _{CH}	CE# Hold Time	Min	0	0	0	ns	
t _{WLWH}	t _{WP}	Write Pulse Width	Min	25	25	25	ns	
t _{WHDL}	t _{WPH}	Write Pulse Width High	Min	20	20	20	ns	
t _{WHWH1}	t _{WHWH1}	Write Buffer Program Operation (2, 3)	Typ	160	160	160	μs	
		Programming Operation (Word and Byte Mode)	Typ ⁽⁴⁾	8	8	8	μs	
			Max	200	200	200	μs	
t _{WHWH2}	t _{WHWH2}	Sector Erase Operation	Typ ⁽⁴⁾	0.2	0.2	0.2	s	
			Max	2	2	2	s	
		Chip Erase Operation	128Mb	Typ ⁽⁴⁾	30	30	30	s
			256Mb		60	60	60	
	t _{VHH}	V _{HH} Rise and Fall Time	Min	250	250	250	ns	
	t _{VCS}	V _{CC} Setup Time	Min	50	50	50	μs	
	t _{BUSY}	WE# High to RY/BY# Low	Max	70	70	70	ns	
	t _{RB}	Recovery Time from RY/BY#	Min	0	0	0	ns	

Notes: 1. Not 100% tested.

2. See table.22 Erase and Programming Performance for more information.

3. For 1~32 words program.

4. Typical values are included for reference only and are not guaranteed or tested. Typical values are measured at V_{CC} = V_{CC} (Typ), V_{IO} = V_{IO} (Typ), and T_A=25°C.

AC CHARACTERISTICS

Table 21. Write (Erase/Program) Operations

(Under recommended operating ranges)

Alternate CE# Controlled Writes

Parameter Symbols		Description		Speed ⁽¹⁾			Unit
JEDEC	Standard			70ns	80ns	90ns	
t _{AVAV}	t _{WC}	Write Cycle Time	Min	70	80	90	ns
t _{AVEL}	t _{AS}	Address Setup Time	Min	0	0	0	ns
	t _{ASO}	Address Setup Time to OE# Low during toggle bit polling	Min	0	0	0	ns
t _{ELAX}	t _{AH}	Address Hold Time	Min	45	45	45	ns
	t _{AHT}	Address Hold Time from CE# or OE# High during toggle bit polling	Min	0	0	0	ns
t _{DVEH}	t _{DS}	Data Setup Time	Min	30	30	30	ns
t _{EHDx}	t _{DH}	Data Hold Time	Min	0	0	0	ns
	T _{CEPH}	CE# High during toggle bit polling	Min	10	10	10	ns
	t _{OEPH}	OE# High during toggle bit polling	Min	10	10	10	ns
t _{GHEL}	t _{GHEL}	Read Recovery Time before Write (OE# High to CE# Low)	Min	0	0	0	ns
t _{WLEL}	t _{WS}	WE# SetupTime	Min	0	0	0	ns
t _{EHWH}	t _{WH}	WE# Hold Time	Min	0	0	0	ns
t _{ELEH}	t _{CP}	Write Pulse Width	Min	35	35	35	ns
t _{EHEL}	t _{CPH}	Write Pulse Width High	Min	20	20	20	ns
t _{WHWH1}	t _{WHWH1}	Write Buffer Program Operation (2, 3)	Typ ⁽⁴⁾	160	160	160	μs
		Programming Operation (Word and Byte mode)	Typ ⁽⁴⁾	8	8	8	μs
			Max	200	200	200	μs
t _{WHWH2}	t _{WHWH2}	Sector Erase Operation	Typ ⁽⁴⁾	0.2	0.2	0.2	s
			Max	2	2	2	s

Notes: 1. Not 100% tested.

2. See table.22 Erase and Programming Performance for more information.

3. For 1~32 words bytes programmed.

4. Typical values are included for reference only and are not guaranteed or tested. Typical values are measured at V_{CC} = V_{CC} (Typ), V_{IO} = V_{IO} (Typ), and TA=25°C.

AC CHARACTERISTICS

Figure 17. AC Waveforms for Chip/Sector Erase Operations Timings

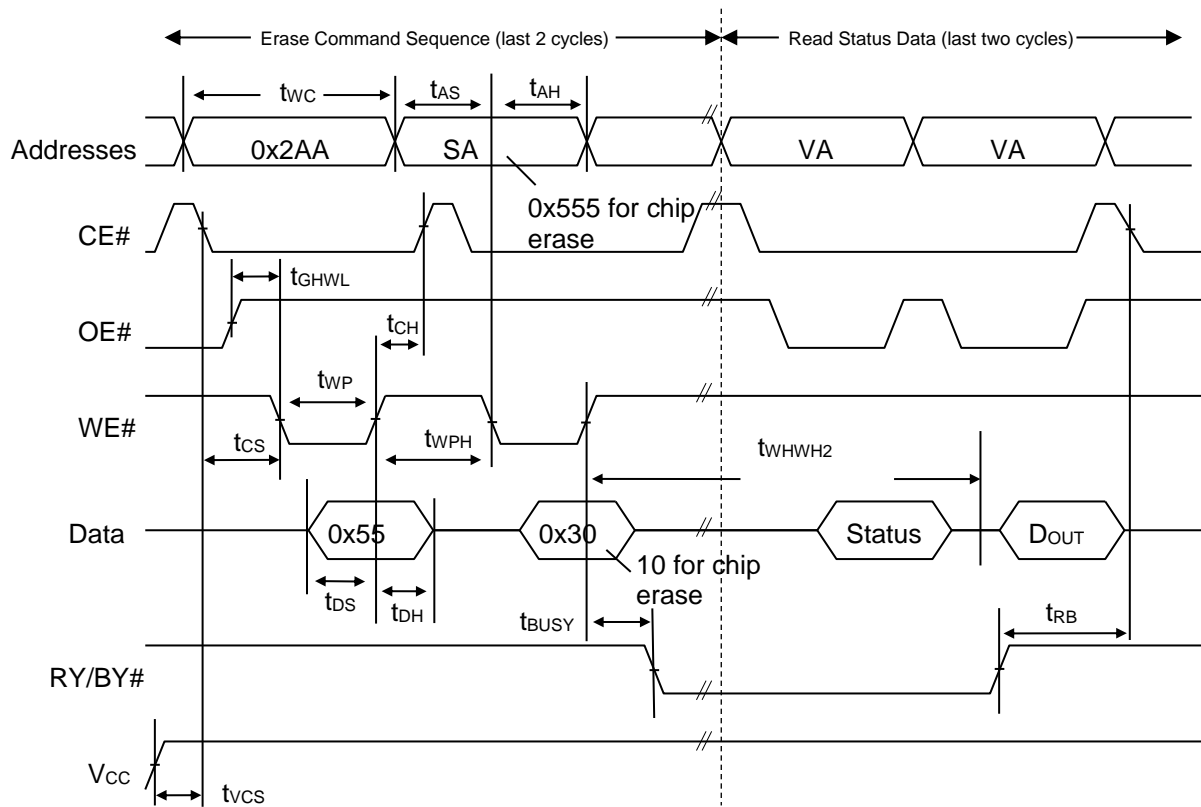

Notes:

1. SA=Sector Address (for sector erase), VA=Valid Address for reading status, D_{out}=true data at read address.
2. V_{cc} shown only to illustrate t_{vcs} measurement references. It cannot occur as shown during a valid command sequence.

Figure 18. Program Operation Timings

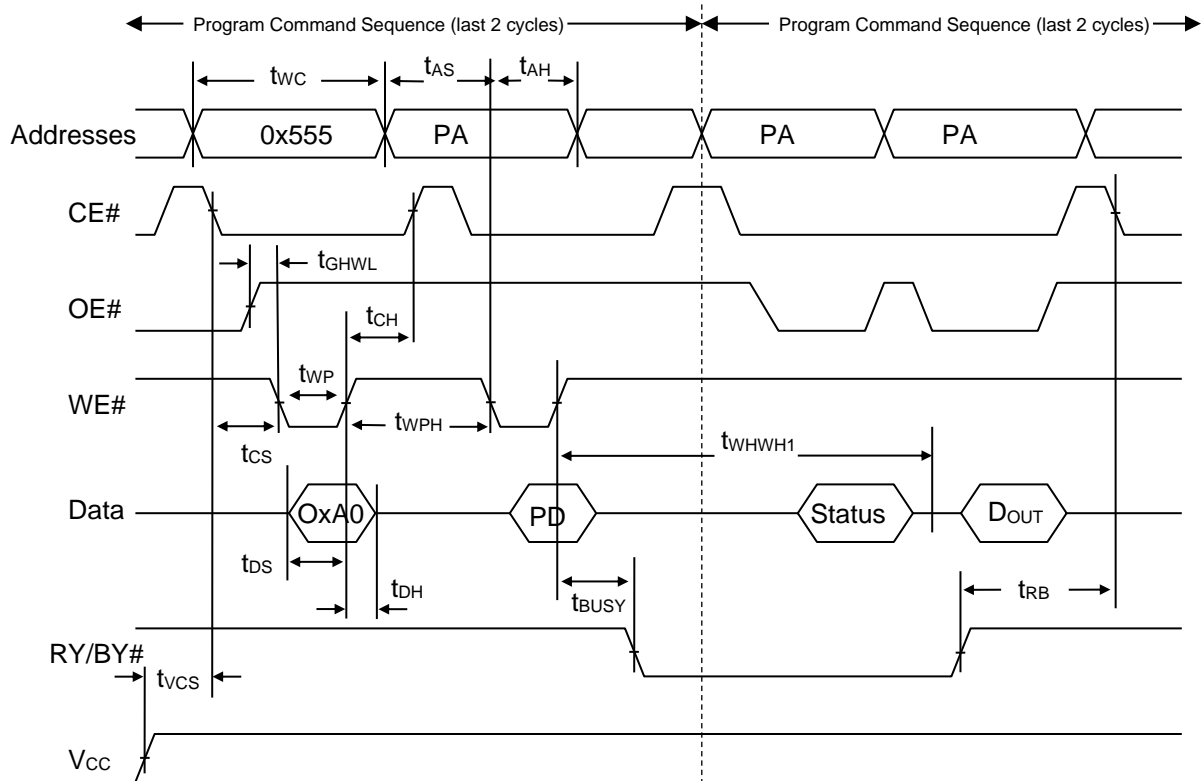

Notes:

1. PA=Program Address, PD=Program Data, D_{OUT} is the true data at the program address.
2. V_{CC} shown in order to illustrate t_{vcs} measurement references. It cannot occur as shown during a valid command sequence.

Figure 19. AC Waveforms for /DATA Polling During Embedded Algorithm Operations

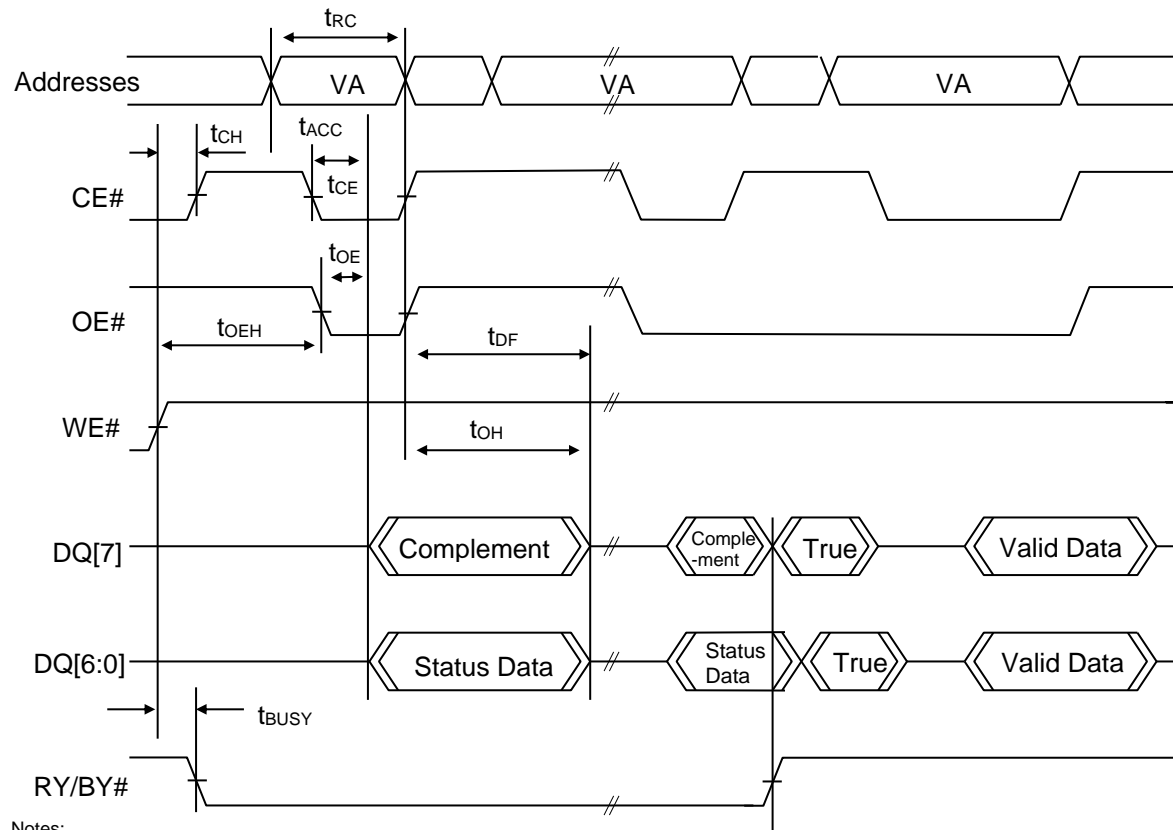

- Notes:
1. VA=Valid Address for reading Data# Polling status data
 2. This diagram shows the first status cycle after the command sequence, the last status read cycle and the array data read cycle.

Figure 20. AC Waveforms for Toggle Bit During Embedded Algorithm Operations

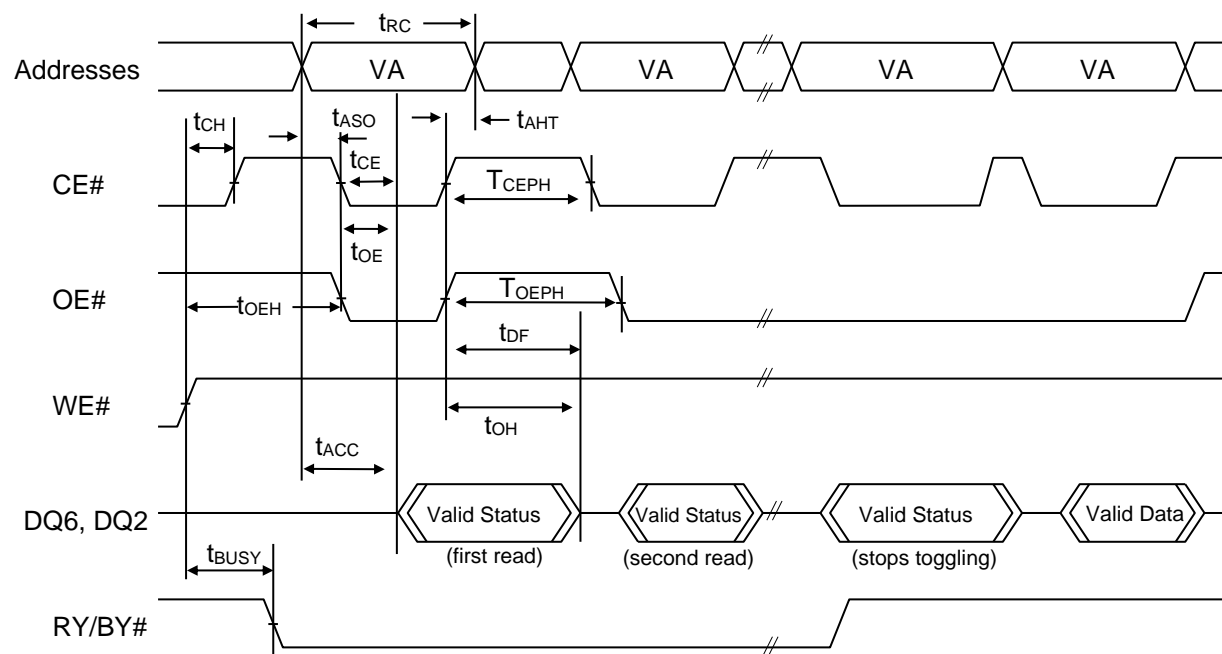
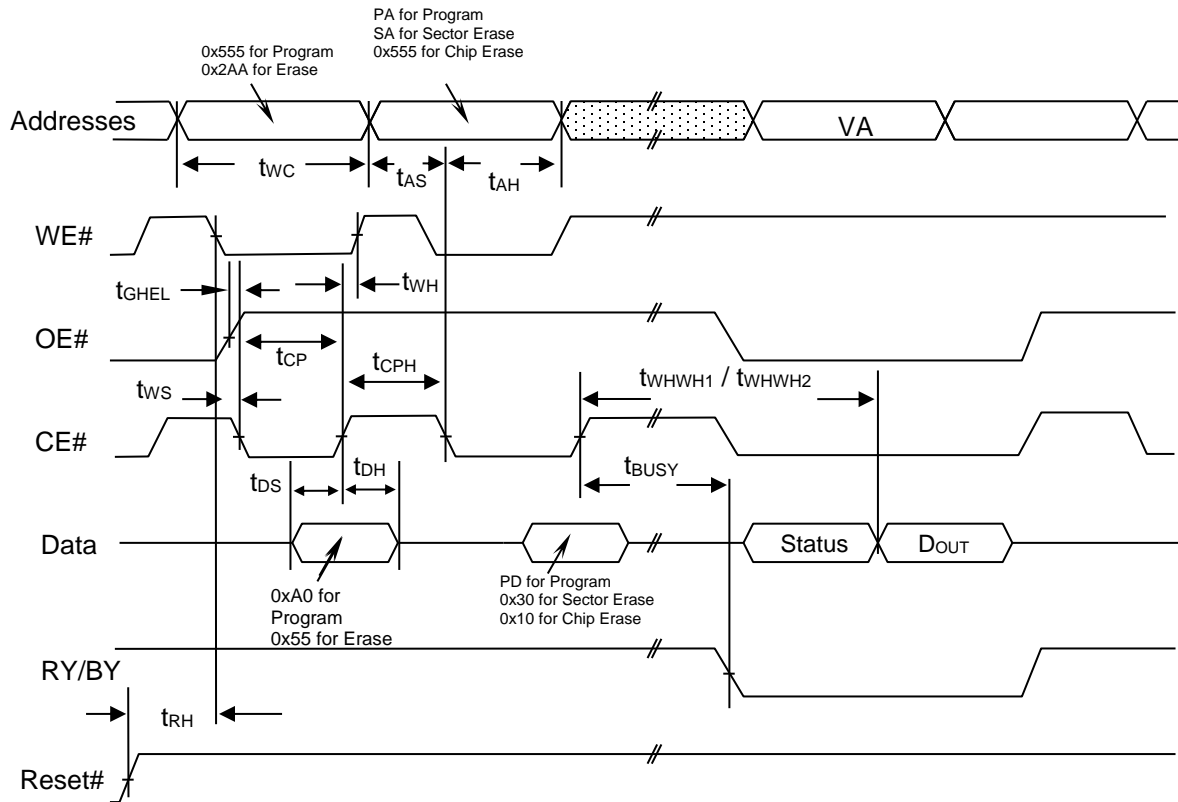

Figure 21. Alternate CE# Controlled Write Operation Timings



Notes:

PA = address of the memory location to be programmed.
 PD = data to be programmed at byte address.
 VA = Valid Address for reading program or erase status
 D_{out} = array data read at VA
 Shown above are the last two cycles of the program or erase command sequence and the last status read cycle
 Reset# shown to illustrate t_{RH} measurement references. It cannot occur as shown during a valid command sequence.

Figure 22. DQ2 vs. DQ6

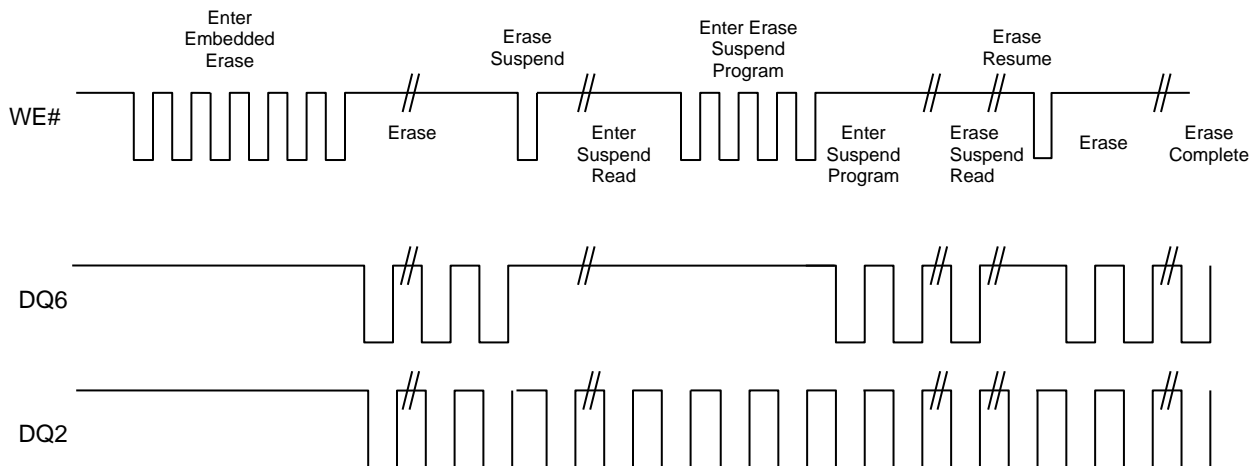

TABLE 22. ERASE AND PROGRAMMING PERFORMANCE

(Under recommended operating ranges)

Parameter		Limits			Comments
		Typ ⁽¹⁾	Max ⁽²⁾	Unit	
Sector Erase Time		0.2	2	sec	Excludes 00h programming prior to erasure
Chip Erase Time	128Mb	30	150 ⁽³⁾	sec	
	256Mb	60	300 ⁽³⁾		
Byte Programming Time		8	200	μs	Excludes system level overhead
Word Programming Time		8	200	μs	
Total Write Buffer time		160	500 ⁽³⁾	μs	
ACC Total Write Buffer time		60	150		
Erase/Program Endurance		100K		cycles	Minimum 100K cycles

Notes:

1. Typical program and erase times assume the following conditions: room temperature, V_{CC} (Typ), V_{IO} (Typ), and checkerboard pattern programmed.
2. Maximum program and erase times assume the following conditions: worst case V_{CC}, 125°C and 100,000 cycles.
3. Not 100% tested.

Table 23. 56-PIN TSOP PIN CAPACITANCE @ 25°C, 1.0MHz

Parameter Symbol	Parameter Description	Test Setup	Typ	Max	Unit
C _{IN}	Input Capacitance	V _{IN} = 0	6	7.5	pF
C _{OUT}	Output Capacitance	V _{OUT} = 0	8.5	12	pF
C _{IN2}	Control Pin Capacitance	V _{IN} = 0	7.5	9	pF
C _{IN3}	WP#/ACC Pin Capacitance	V _{IN} = 0	13	18	pF

Note: Test conditions are Temperature = 25°C and f = 1.0 MHz.**Table 24. 64-BALL BGA BALL CAPACITANCE @ 25°C, 1.0MHz**

Parameter Symbol	Parameter Description	Test Setup	Typ	Max	Unit
C _{IN}	Input Capacitance	V _{IN} = 0	5.5	6.5	pF
C _{OUT}	Output Capacitance	V _{OUT} = 0	4.0	6.0	pF
C _{IN2}	Control Pin Capacitance	V _{IN} = 0	4.5	6.5	pF
C _{IN3}	WP#/ACC Pin Capacitance	V _{IN} = 0	11.0	15.0	pF

Note: Test conditions are Temperature = 25°C and f = 1.0 MHz.

ABSOLUTE MAXIMUM RATINGS

Parameter		Value
Storage Temperature		-65°C to +150°C
Plastic Packages		-65°C to +125°C
Ambient Temperature With Power Applied		-65°C to +125°C
Surface Mount Lead Soldering Temperature	Standard Package	240°C 3 Seconds
	Lead-free Package	260°C 3 Seconds
Output Short Circuit Current ¹		200mA
Voltage with Respect to Ground	WP#/ACC ²	-0.5V to 9.5V
	All other pins ³	-0.5V to $V_{IO} + 0.5V$
	V_{CC} , V_{IO}	-0.5V to +4.0V

Notes:

1. No more than one output shorted at a time. Duration of the short circuit should not be greater than one second.
2. Minimum DC input voltage on WP#/ACC pin is -0.5V. During voltage transitions, WP#/ACC pin may undershoot V_{SS} to -1.0V for periods of up to 50ns and to -2.0V for periods of up to 20ns. See figure below.
3. Minimum DC voltage on input or I/O pins is -0.5 V. During voltage transitions, inputs may undershoot V_{SS} to -1.0V for periods of up to 50ns and to -2.0 V for periods of up to 20ns. See figure below. Maximum DC voltage on output and I/O pins is $V_{CC} + 0.5 V$. During voltage transitions, outputs may overshoot to $V_{CC} + 2.0 V$ for periods up to 20ns. See figure below.
4. Stresses above the values so mentioned above may cause permanent damage to the device. These values are for a stress rating only and do not imply that the device should be operated at conditions up to or above these values. Exposure of the device to the maximum rating values for extended periods of time may adversely affect the device reliability.

RECOMMENDED OPERATING RANGES⁽¹⁾

Parameter		Value	
Ambient Operating Temperature (T_A)	Extended Grade	-40°C to 105°C	
	Automotive Grade A3	-40°C to 125°C	
Speed and V_{CC} , V_{IO} Power Supply	70ns ⁽²⁾	$V_{CC} = 3.0V$ to 3.6V, $V_{IO} = 3.0V$ to 3.6V.	
	80ns ⁽²⁾	$V_{CC} = 2.7 V$ to 3.6V, $V_{IO} = 2.7V$ to 3.6V.	
	90ns ⁽²⁾	$V_{CC} = 3.0V$ to 3.6V, $V_{IO} = 1.65V$ to V_{CC} .	

Notes

1. Recommended Operating Ranges define those limits between which the functionality of the device is guaranteed.
2. 70ns device is tested at $V_{CC}=3.0V$ to 3.6V, $V_{IO} = 3.0V$ to 3.6V, and becomes 80ns at $V_{CC}=V_{IO}=2.7V-3.6V$, 90ns at $V_{IO}=1.65V -V_{CC}$.

Figure 23. Overshoot & Undershoot Waveform

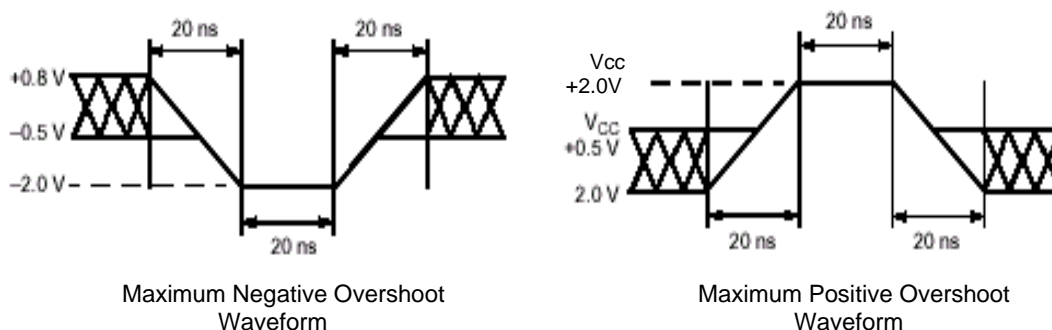

Power-Up and Power-Down

During power-up or power-down V_{CC} must always be greater than or equal to V_{IO} ($V_{CC} \geq V_{IO}$).

The device ignores all inputs until a time delay of t_{VCS} has elapsed after the moment that V_{CC} and V_{IO} both rise above, and stay above, the minimum V_{CC} and V_{IO} thresholds. During t_{VCS} the device is performing power on reset operations.

During power-down or voltage drops below V_{CC} Lockout maximum (V_{LKO}), the V_{CC} and V_{IO} voltage must drop below V_{CC} Reset (V_{RST}) minimum for a period of t_{PD} for the part to initialize correctly when V_{CC} and V_{IO} again rise to their operating ranges. If during a voltage drop the V_{CC} stays above V_{LKO} maximum the part will stay and will work correctly when V_{CC} is again above V_{CC} minimum. If the part locks up from improper initialization, a hardware reset can be used to initialize the part correctly.

Table 25. Power-Up & Power-Down Voltage and Timing

Parameter	Parameter	Min	Typ	Max	Unit
$V_{LKO}^{(1)}$	Supply voltage (Erase and Program lock-out). V_{CC} below which re-initialization is required.	2.2V		2.5	V
$V_{RST}^{(1)}$	V_{CC} and V_{IO} Low voltage needed to ensure initialization will occur	0.4			V
$t_{VCS}^{(1)}$	V_{CC} Setup Time. V_{CC} / V_{IO} minimum voltage to first access	50			us
$t_{PD}^{(1)}$	Duration of $V_{CC} < V_{RST}$	1.0			ms

Note:

1. Not 100% tested.

Figure 24. Power-Up

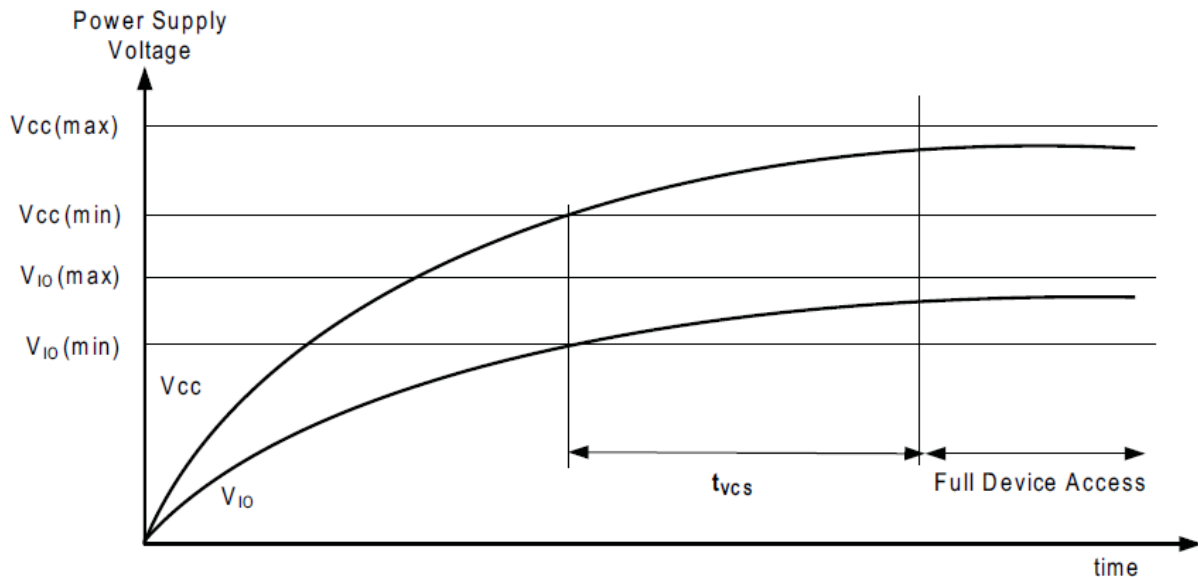

Figure 25. Power-Down/Power-Up and Voltage drop

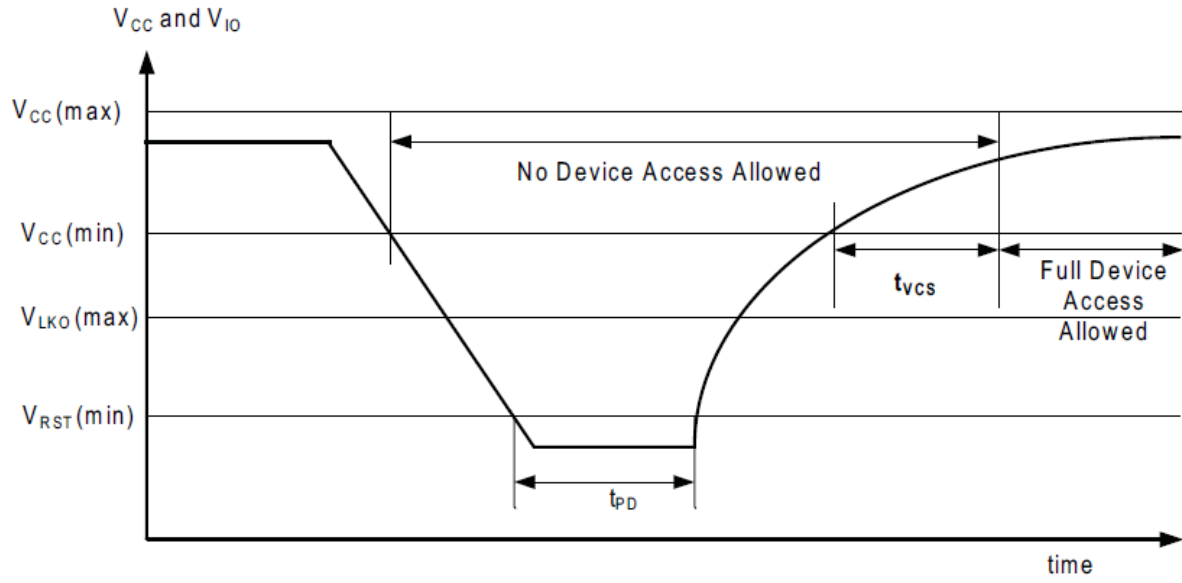
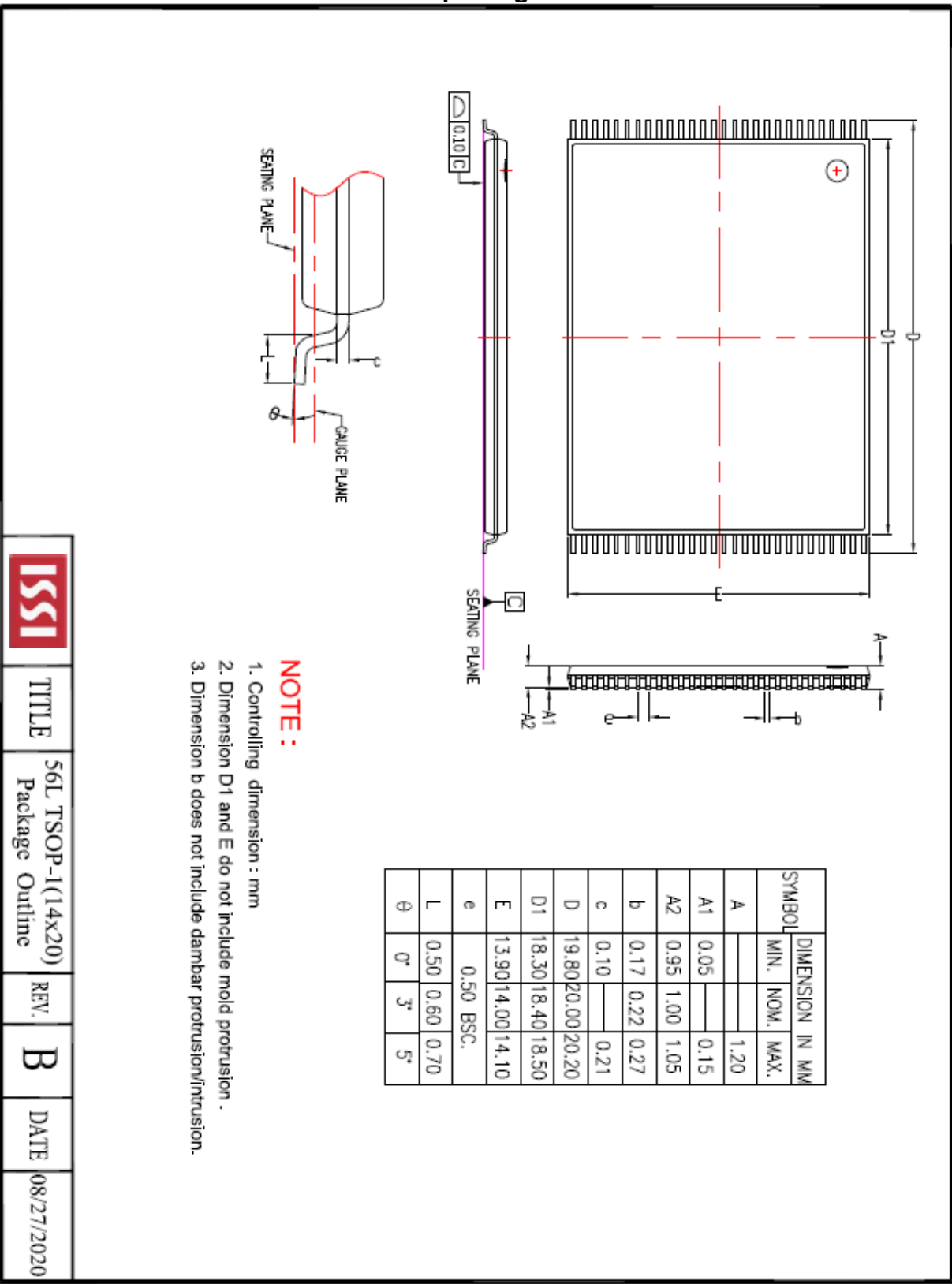
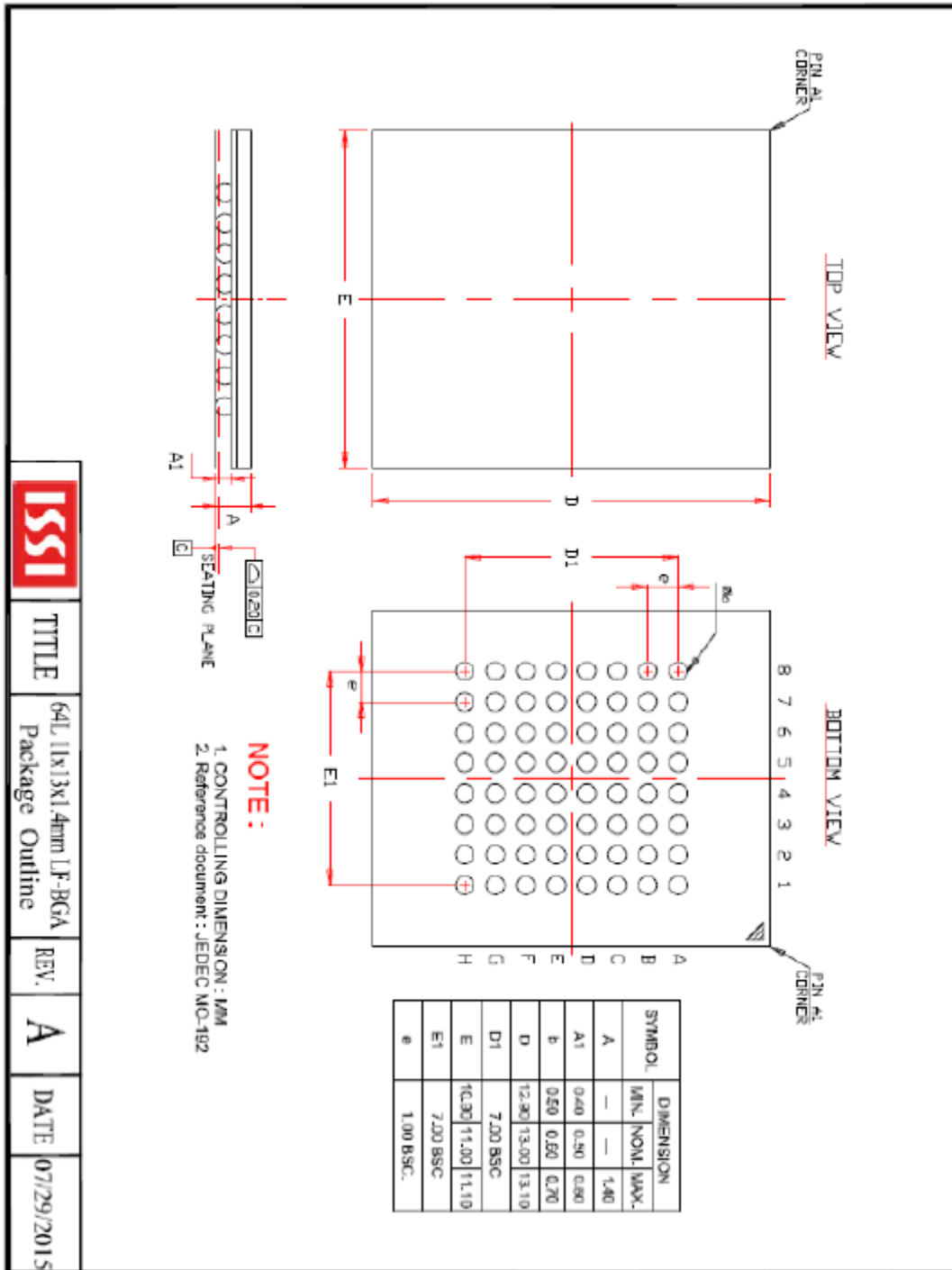

FIGURE 23. 56L TSOP 14mm x 20mm package outline



	TITLE	56L TSOP-1(14x20) Package Outline	REV.	B	DATE	08/27/2020
--	-------	--------------------------------------	------	----------	------	------------

FIGURE 24. 64-ball Ball Grid Array (BGA), 13 X11 mm, Pitch 1mm package outline



ISSI	TITLE	64L 11x13x1.4mm LF-BGA Package Outline	REV.	A	DATE	07/29/2015
-------------	-------	--	------	---	------	------------

FIGURE 25. 64-ball Ball Grid Array (BGA), 9 X 9 mm, Pitch 1mm package outline

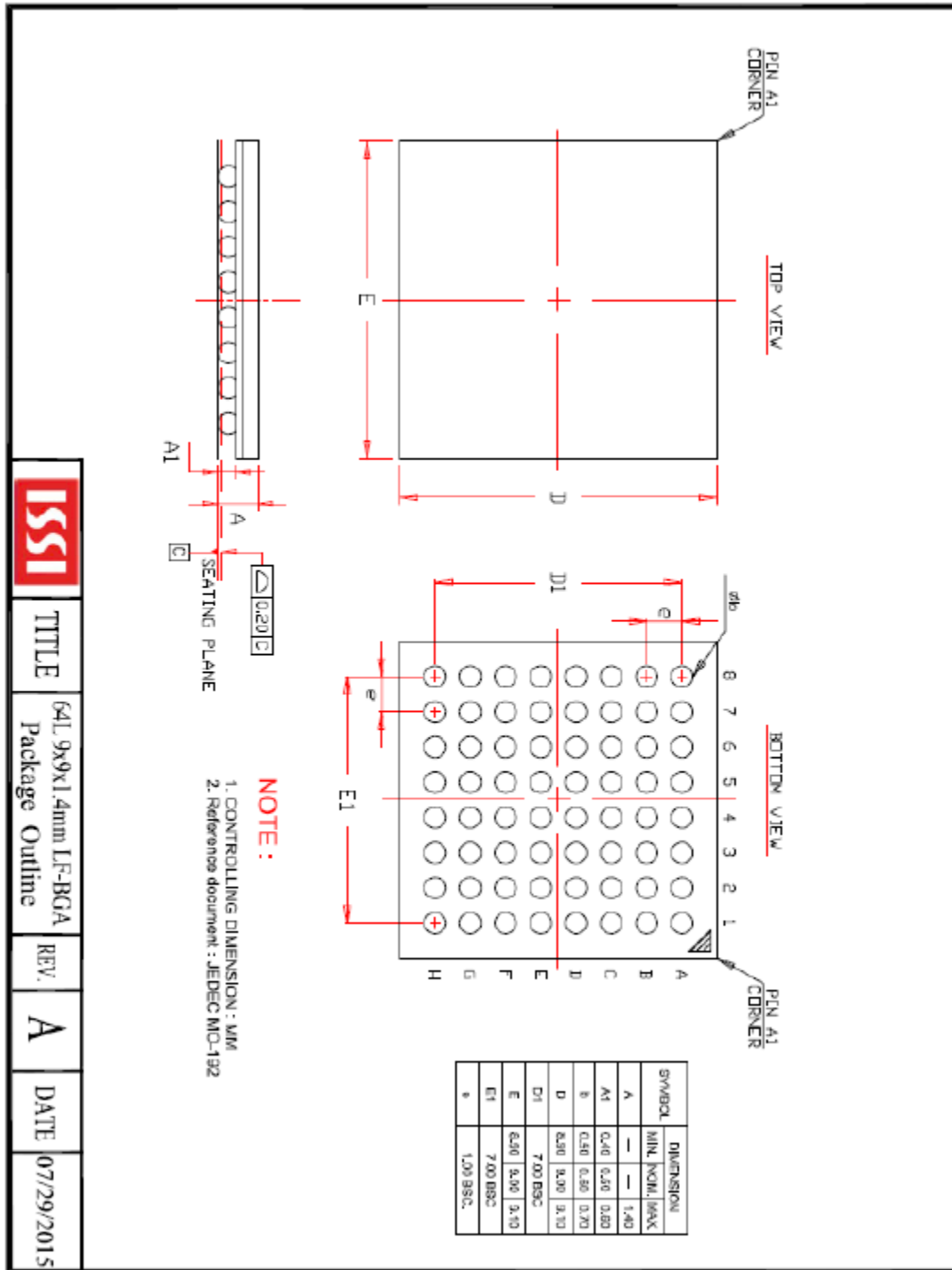

ISSI	TITLE	64L 9x9x1.4mm LFBGA Package Outline	REV.	A	DATE	07/29/2015
-------------	-------	-------------------------------------	------	---	------	------------

FIGURE 26. 56-ball Ball Grid Array (BGA), 9 X 7 mm, Pitch 0.8mm package outline

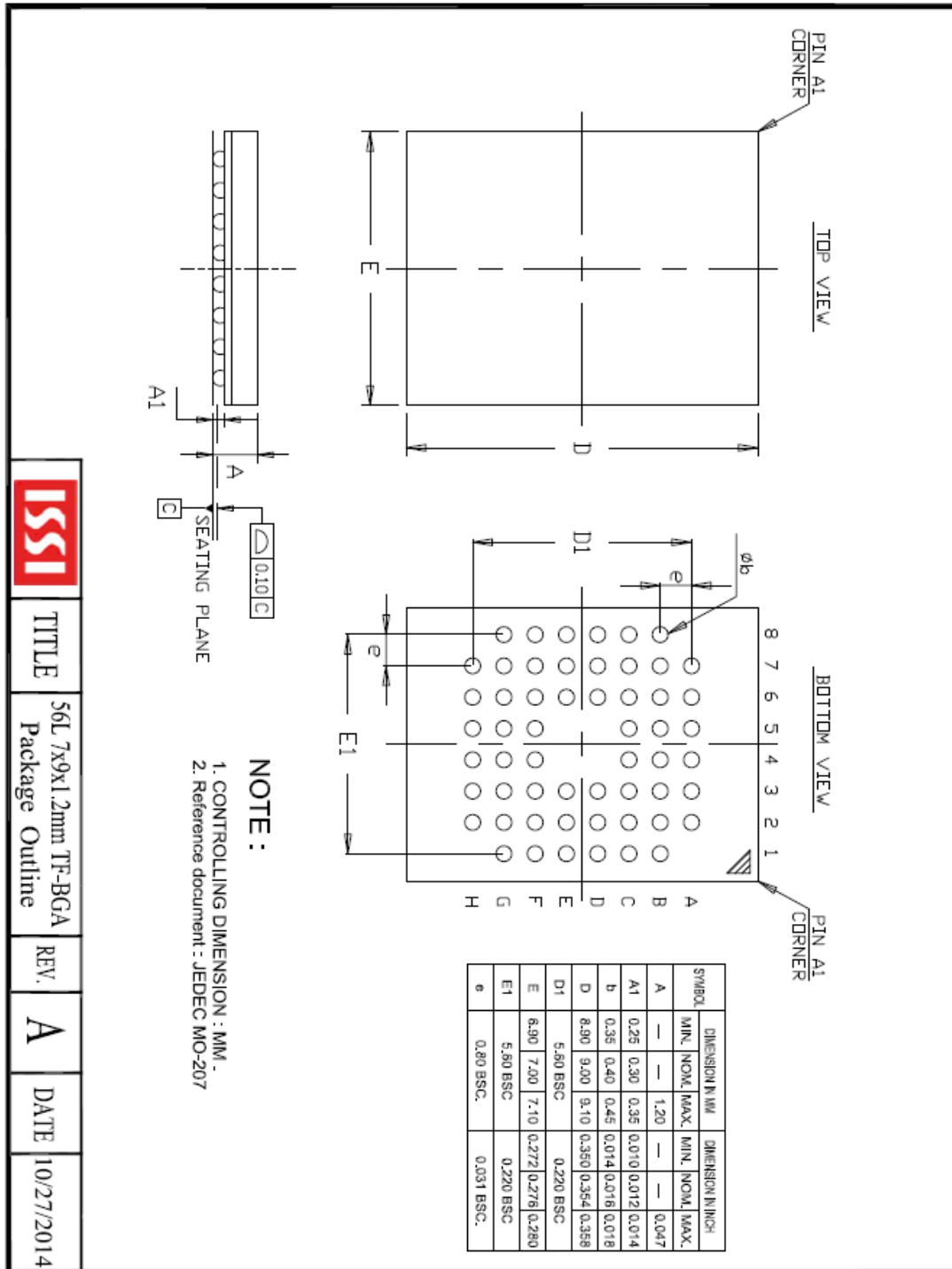

TITLE 56L 7x9x1.2mm TF-BGA Package Outline

REV. A

DATE 10/27/2014

ORDERING INFORMATION

IS29GL 256 - 70 D L E T

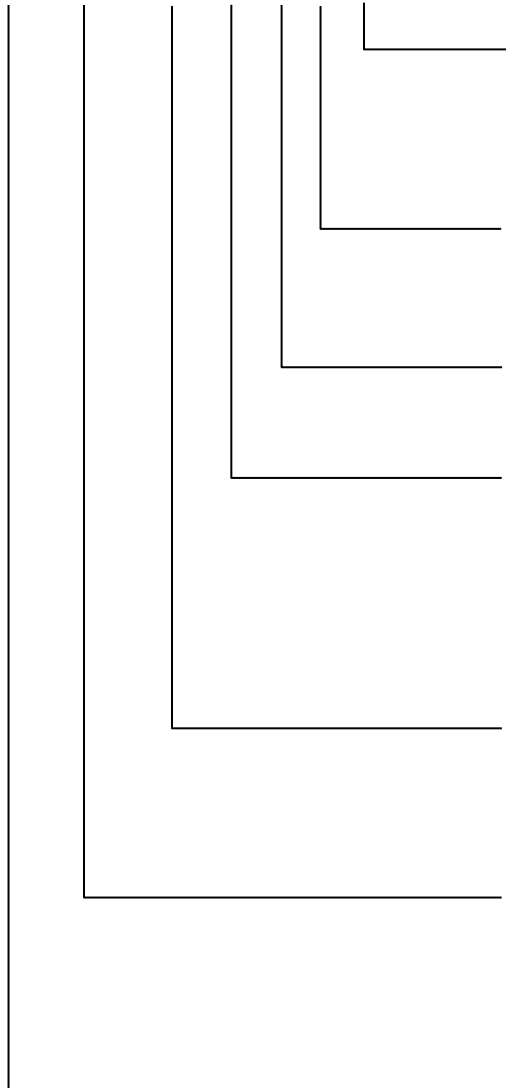

SECTOR for WRITE PROTECT (WP#/ACC=L)

T = highest address sector protected
B = lowest address sector protected
H = highest address sector protected, No BYTE# ⁽¹⁾
L = lowest address sector protected, No BYTE# ⁽¹⁾

TEMPERATURE RANGE

E = Extended (-40°C to +105°C)
A3 = Automotive Grade (-40°C to +125°C)

PACKAGING CONTENT

L = RoHS compliant

PACKAGE

S = 56-pin TSOP
F = 64-ball BGA 1.0mm pitch, 13mm x 11mm (Call Factory)
D = 64-ball BGA 1.0mm pitch, 9mm x 9mm
G = 56-ball BGA 0.8mm pitch, 9mm x 7mm (Call Factory)
W = KGD (Call Factory)

SPEED

70 = 70ns ⁽²⁾ at V_{CC}=3.0~3.6V, V_{IO}=3.0~3.6V

Density

128 =128 Mb
256 =256 Mb

BASE PART NUMBER

IS = Integrated Silicon Solution Inc.

29GL = FLASH, 3V Page Mode Flash Memory

Notes:

1. No BYTE# device supports x16 org. only.
2. Maximum speed becomes 80ns when V_{CC} = 2.7V ~ 3.6V, V_{IO} = 2.7V ~ 3.6V, and 90ns when V_{CC} = 2.7V ~ 3.6V, V_{IO} = 1.65V~V_{CC}.

256Mb

Temperature	Order Part Number ⁽¹⁾	Sector for Write Protect ⁽²⁾	Package
E Grade: -40 °C to +105 °C	IS29GL256-70SLET	High	56-pin TSOP
	IS29GL256-70DLET	High	64-ball BGA (9x9mm)
	IS29GL256-70SLEB	Low	56-pin TSOP
	IS29GL256-70DLEB	Low	64-ball BGA (9x9mm)
E Grade: -40 °C to +105 °C, No BYTE#	IS29GL256-70SLEH	High	56-pin TSOP
	IS29GL256-70DLEH	High	64-ball BGA (9x9mm)
	IS29GL256-70SLEL	Low	56-pin TSOP
	IS29GL256-70DLEL	Low	64-ball BGA (9x9mm)
Auto A3 Grade: -40 °C to +125 °C	IS29GL256-70SLA3T	High	56-pin TSOP
	IS29GL256-70DLA3T	High	64-ball BGA (9x9mm)
	IS29GL256-70SLA3B	Low	56-pin TSOP
	IS29GL256-70DLA3B	Low	64-ball BGA (9x9mm)
Auto A3 Grade: -40 °C to +125 °C, No BYTE#	IS29GL256-70SLA3H	High	56-pin TSOP
	IS29GL256-70DLA3H	High	64-ball BGA (9x9mm)
	IS29GL256-70SLA3L	Low	56-pin TSOP
	IS29GL256-70DLA3L	Low	64-ball BGA (9x9mm)

128Mb

Temperature	Order Part Number ⁽¹⁾	Sector for Write Protect ⁽²⁾	Package
E Grade: -40 °C to +105 °C	IS29GL128-70SLET	High	56-pin TSOP
	IS29GL128-70FLET	High	64-ball BGA (13x11mm)
	IS29GL128-70DLET	High	64-ball BGA (9x9mm)
	IS29GL128-70SLEB	Low	56-pin TSOP
	IS29GL128-70FLEB	Low	64-ball BGA (13x11mm)
	IS29GL128-70DLEB	Low	64-ball BGA (9x9mm)
E Grade: -40 °C to +105 °C, No BYTE#	IS29GL128-70SLEH	High	56-pin TSOP
	IS29GL128-70FLEH	High	64-ball BGA (13x11mm)
	IS29GL128-70DLEH	High	64-ball BGA (9x9mm)
	IS29GL128-70SLEL	Low	56-pin TSOP
	IS29GL128-70FLEL	Low	64-ball BGA (13x11mm)
	IS29GL128-70DLEL	Low	64-ball BGA (9x9mm)
Auto A3 Grade: -40 °C to +125 °C	IS29GL128-70SLA3T	High	56-pin TSOP
	IS29GL128-70FLA3T	High	64-ball BGA (13x11mm)
	IS29GL128-70DLA3T	High	64-ball BGA (9x9mm)
	IS29GL128-70SLA3B	Low	56-pin TSOP
	IS29GL128-70FLA3B	Low	64-ball BGA (13x11mm)
	IS29GL128-70DLA3B	Low	64-ball BGA (9x9mm)
Auto A3 Grade: -40 °C to +125 °C, No BYTE#	IS29GL128-70SLA3H	High	56-pin TSOP
	IS29GL128-70FLA3H	High	64-ball BGA (13x11mm)
	IS29GL128-70DLA3H	High	64-ball BGA (9x9mm)
	IS29GL128-70SLA3L	Low	56-pin TSOP
	IS29GL128-70FLA3L	Low	64-ball BGA (13x11mm)
	IS29GL128-70DLA3L	Low	64-ball BGA (9x9mm)

Notes:

1. A3: Meet AEC-Q100 requirements with PPAP
2. WP#/ACC=L

Looking for pricing, stock, or lifecycle information?

Click below to explore more details on WIN SOURCE:

- ⊖ [View IS29GL256-70SLET on WIN SOURCE](#)
- ⊖ [ISSI, Integrated Silicon Solution Inc Information](#)

Optimize Your Supply Chain with WIN SOURCE Solutions

- ✓ Global Sourcing Solution
- ✓ Obsolete Management
- ✓ Cost Control Management
- ✓ Shortage Management
- ✓ Alternative Solution
- ✓ Excess Inventory Management