



**THE DATASHEET OF
P3S0200GMX**



P3S0200

I3C switch with hardware select and enable

Rev. 1.0 — 14 February 2022

Product data sheet

1 General description

The P3S0200 is ideally suited for the switching of high-speed I3C signals in communication and server applications, such as servers, workstations, and notebooks that have limited I3C I/Os. The wide bandwidth (52 MHz) of this switch allows signal to pass with minimum edge and phase distortion. The device multiplexes differential outputs from the I3C controller to one of two corresponding targets with hardware select pin. The switch is bidirectional and offers little or no attenuation of the high-speed signals at the outputs. It is designed for low bit-to-bit skew and high channel-to-channel noise isolation.

2 Features and benefits

- Wide supply voltage range from 2.3 V to 3.6 V
- Switch voltage accepts signals up to 5.5 V
- 1.8 V control logic at $V_{CC} = 3.6$ V
- Low-power mode when \overline{OE} is HIGH (2 μ A maximum)
- 6 Ω (maximum) ON resistance
- 0.1 Ω (typical) ON resistance mismatch between channels
- 6 pF (typical) ON-state capacitance
- High bandwidth (52 MHz typical)
- Latch-up performance exceeds 100 mA per JESD 78B Class II Level A
- ESD protection:
 - HBM JESD22-A114F Class 3A exceeds 8000 V
 - CDM JESD22-C101E exceeds 1000 V
 - HBM exceeds 12000 V for I/O to GND protection
- Specified from -40 °C to +85 °C

3 Applications

- I3C or I²C 2:1 or 1:2 mux with hardware select pin allowing bus voltage up to 5.5 V

4 Ordering information

Table 1. Ordering information

Type number	Topside marking ^[1]	Package		
		Name	Description	Version
P3S0200GM	x00	XQFN10	plastic extremely thin quad flat package; no leads; 10 terminals; body 2 × 1.55 × 0.5 mm	SOT1049-3

[1] The pin 1 indicator is located on the lower left corner of the device, below the marking code.



4.1 Ordering options

Table 2. Ordering options

Type number	Orderable part number	Package	Packing method ^[1]	Minimum order quantity	Temperature
P3S0200GM	P3S0200GMX	XQFN10	REEL 7" Q1 NDP	5000	T _{amb} = -40 °C to +85 °C

[1] Standard packing quantities and other packaging data are available at www.nxp.com/packages/.

5 Functional diagram

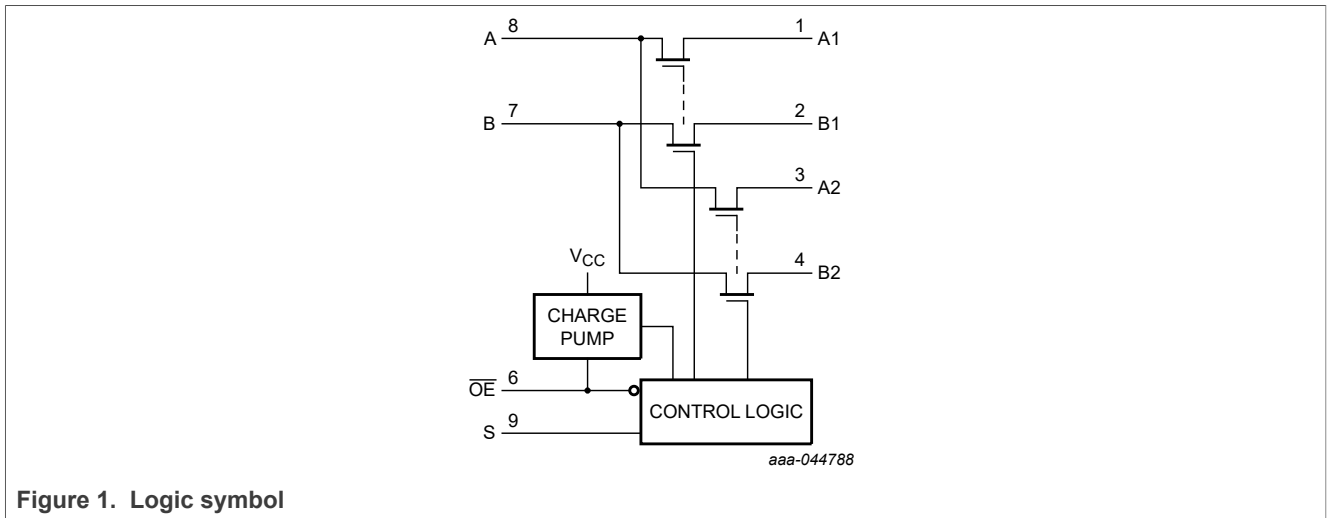

6 Pinning information

6.1 Pinning

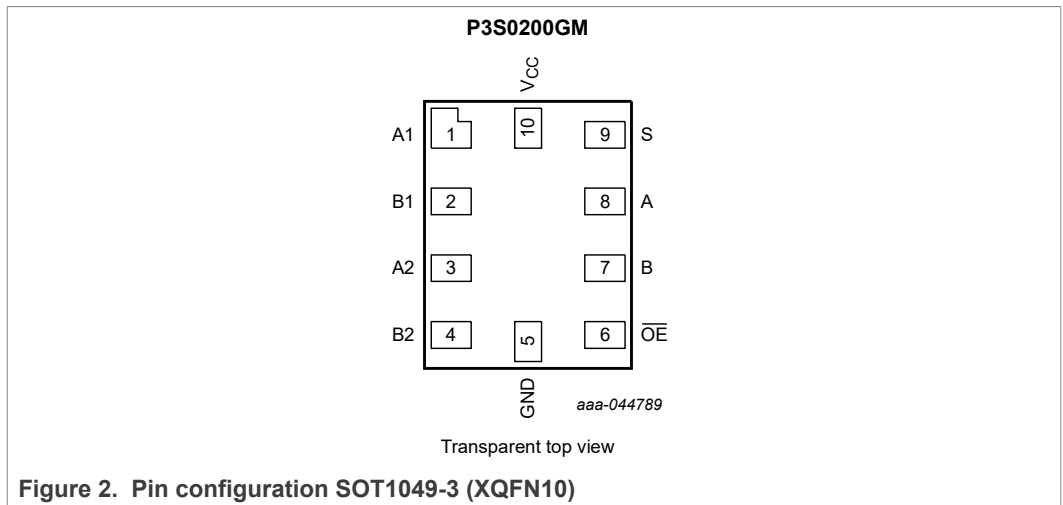

6.2 Pin description

Table 3. Pin description

Symbol	Pin	Description
A1	1	independent input or output
B1	2	independent input or output
A2	3	independent input or output
B2	4	independent input or output
GND	5	ground (0 V)
OE	6	output enable input (active LOW)
B	7	common input or output
A	8	common input or output
S	9	select input
V _{CC}	10	supply voltage

7 Functional description

Table 4. Function table^[1]

Input		Channel
S	OE	
L	L	A = A1; B = B1
H	L	A = A2; B = B2
X	H	switches off

[1] H = HIGH voltage level; L = LOW voltage level; X = don't care.

8 Limiting values

Table 5. Limiting values

In accordance with the Absolute Maximum Rating System (IEC 60134). Voltages are referenced to GND (ground = 0 V).

Symbol	Parameter	Conditions	Min	Max	Unit
V _{CC}	supply voltage		-0.5	+4.6	V
V _I	input voltage	S, OE input	^[1] -0.5	+7.0	V
V _{SW}	switch voltage		^[2] -0.5	+7.0	V
I _{IK}	input clamping current	V _I < -0.5 V	-50	-	mA
I _{SK}	switch clamping current	V _I < -0.5 V	-50	-	mA
I _{SW}	switch current		-	±120	mA
I _{CC}	supply current		-	+100	mA
I _{GND}	ground current		-100	-	mA
T _{stg}	storage temperature		-65	+150	°C
P _{tot}	total power dissipation	T _{amb} = -40 °C to +125 °C	-	250	mW

- [1] The minimum input voltage rating may be exceeded if the input current rating is observed.
 [2] The minimum and maximum switch voltage ratings may be exceeded if the switch clamping current rating is observed.

9 Recommended operating conditions

Table 6. Recommended operating conditions

Symbol	Parameter	Conditions	Min	Max	Unit
V_{CC}	supply voltage		2.3	3.6	V
V_I	input voltage	S, \overline{OE} input	0	V_{CC}	V
V_{SW}	switch voltage		0	5.5	V
T_{amb}	ambient temperature		-40	+85	°C

10 Static characteristics

Table 7. Static characteristics

At recommended operating conditions; voltages are referenced to GND (ground 0 V); $T_{amb} = -40\text{ °C}$ to $+85\text{ °C}$

Symbol	Parameter	Conditions	Min	Typ	Max	Unit
V_{IH}	HIGH-level input voltage	$V_{CC} = 2.3\text{ V}$ to 2.7 V	$0.46V_{CC}$	-	-	V
		$V_{CC} = 2.7\text{ V}$ to 3.6 V	$0.46V_{CC}$	-	-	V
V_{IL}	LOW-level input voltage	$V_{CC} = 2.3\text{ V}$ to 2.7 V	-	-	$0.25V_{CC}$	V
		$V_{CC} = 2.7\text{ V}$ to 3.6 V	-	-	$0.25V_{CC}$	V
V_{IK}	input clamping voltage	$V_{CC} = 2.7\text{ V}, 3.6\text{ V}; I_I = -18\text{ mA}$	-	-	-1.8	V
I_I	input leakage current	S, \overline{OE} input; $V_{CC} = 0\text{ V}, 2.7\text{ V}, 3.6\text{ V}; V_I = \text{GND}$ to 3.6 V	-	0.01	± 1	μA
I_{OFF}	power-off leakage current	per pin; $V_{CC} = 0\text{ V}$				
		$V_{SW} = 0\text{ V}$ to 2.7 V	-	0.01	± 2.0	μA
		$V_{SW} = 0\text{ V}$ to 3.6 V	-	0.01	± 2.0	μA
		$V_{SW} = 0\text{ V}$ to 5.25 V	-	0.01	± 3.0	μA
$I_{S(OFF)}$	OFF-state leakage current	A and B ports; see Figure 3				
		$V_{CC} = 2.7\text{ V}, 3.6\text{ V}$	-	-	± 1	μA
I_{CC}	supply current	$V_{CC} = 2.7\text{ V}, 3.6\text{ V}$				
		$\overline{OE} = \text{GND}$	-	18.5	30	μA
		$\overline{OE} = V_{CC}$ (low-power mode)	-	0.01	2	μA
ΔI_{CC}	additional supply current	S, \overline{OE} input; one input at 1.8 V ; other inputs at GND or V_{CC}				
		$V_{CC} = 2.7\text{ V}$	-	0.8	1.8	μA
		$V_{CC} = 3.6\text{ V}$	-	12.5	20	μA
C_I	input capacitance	$V_{SW} = \text{GND}$ or V_{CC} ; $V_{CC} = 2.5\text{ V}, 3.3\text{ V}$	-	1	2.5	pF

Table 7. Static characteristics...continued

At recommended operating conditions; voltages are referenced to GND (ground 0 V); $T_{amb} = -40\text{ }^{\circ}\text{C}$ to $+85\text{ }^{\circ}\text{C}$

Symbol	Parameter	Conditions	Min	Typ	Max	Unit
$C_{S(OFF)}$	OFF-state capacitance	$V_{SW} = \text{GND or } V_{CC}; V_{CC} = 2.5\text{ V}, 3.3\text{ V}$	-	3	5.0	pF
$C_{S(ON)}$	ON-state capacitance	$V_{SW} = \text{GND or } V_{CC}; V_{CC} = 2.5\text{ V}, 3.3\text{ V}$	-	6	7.5	pF

10.1 Test circuits

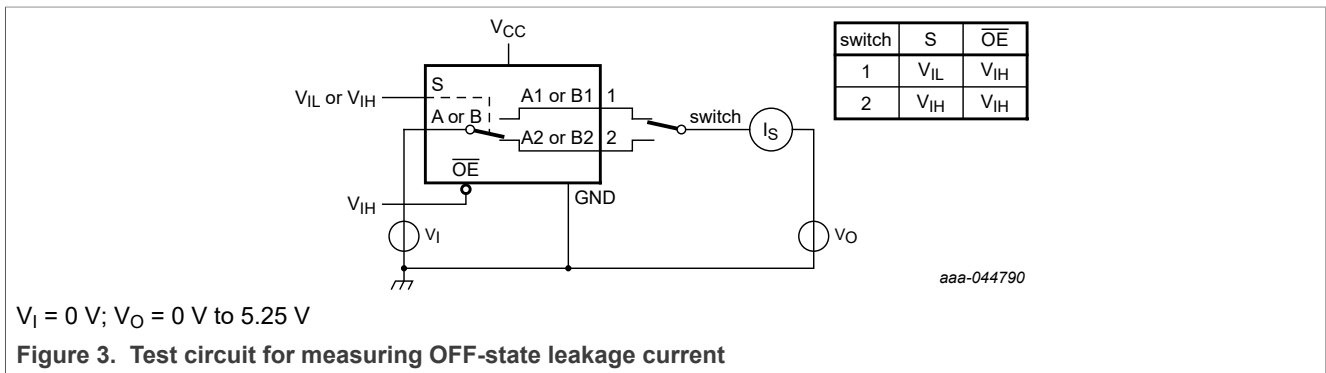

10.2 ON resistance

Table 8. ON resistance

At recommended operating conditions; voltages are referenced to GND (ground = 0 V); for graphs see Figure 5; $T_{amb} = -40\text{ }^{\circ}\text{C}$ to $+85\text{ }^{\circ}\text{C}$.

Symbol	Parameter	Conditions	Min	Typ ^[1]	Max	Unit
R_{ON}	ON resistance	$V_{CC} = 2.3\text{ V}, 3.0\text{ V}$ see Figure 4				
		$V_I = 0\text{ V}; I_I = 30\text{ mA}$	-	3.6	6	Ω
		$V_I = 2.4\text{ V}; I_I = -15\text{ mA}$	-	4.3	7	Ω
ΔR_{ON}	ON resistance mismatch between channels	$V_{CC} = 2.3\text{ V}, 3.0\text{ V}$ [2]				
		$V_I = 0\text{ V}; I_I = 30\text{ mA}$	-	0.1	-	Ω
		$V_I = 1.7\text{ V}; I_I = -15\text{ mA}$	-	0.1	-	Ω
$R_{ON(Flat)}$	ON resistance (flatness)	$V_{CC} = 2.3\text{ V}, 3.0\text{ V}; V_I = 0\text{ V to } V_{CC}$ [3]				
		$I_I = 30\text{ mA}$	-	0.8	-	Ω
		$I_I = -15\text{ mA}$	-	0.7	-	Ω

[1] Typical values are measured at $T_{amb} = 25\text{ }^{\circ}\text{C}$.
 [2] Measured at identical V_{CC} , temperature and input voltage.
 [3] Flatness is defined as the difference between the maximum and minimum value of ON resistance measured at identical V_{CC} and temperature.

10.3 ON resistance test circuit and waveforms

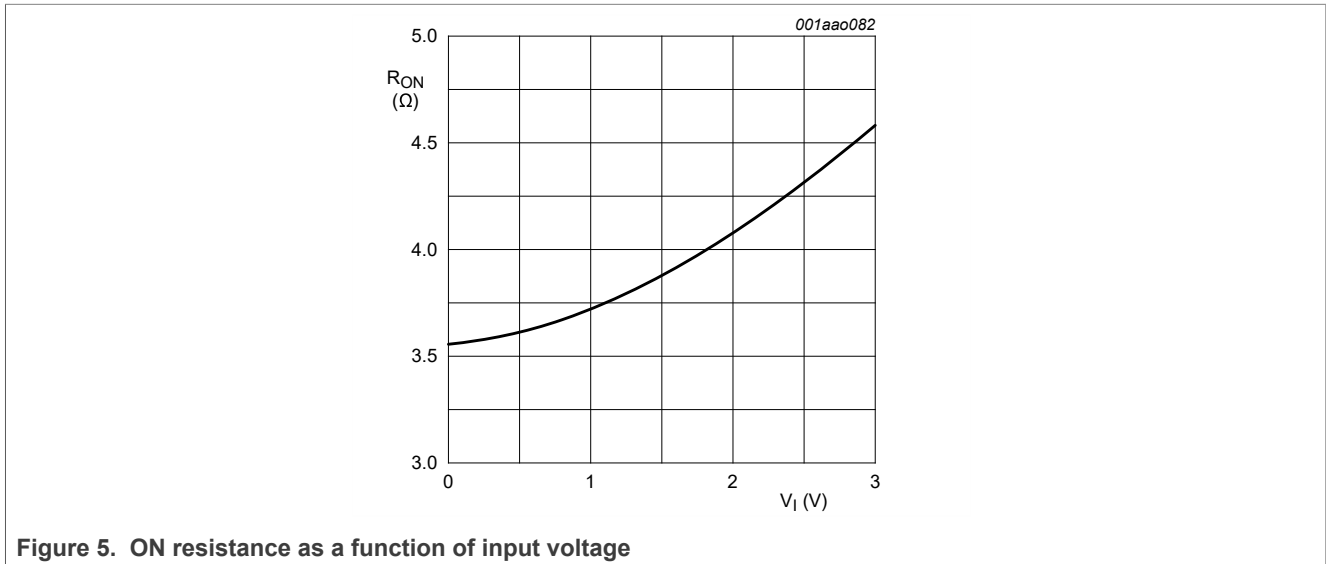
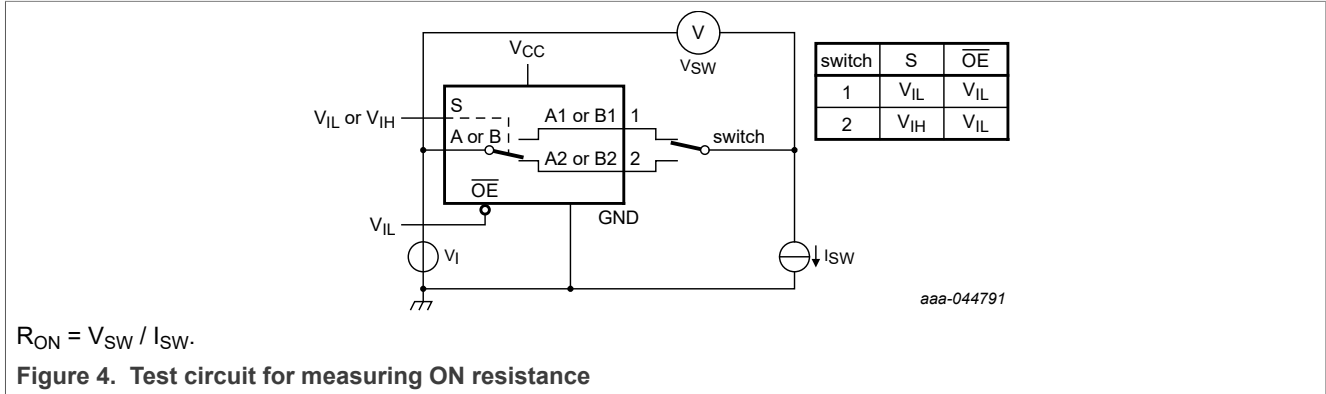

11 Dynamic characteristics

Table 9. Dynamic characteristics

At recommended operating conditions; voltages are referenced to GND (ground = 0 V); for test circuit, see Figure 9.

Symbol	Parameter	Conditions	Min	Typ ^[1]	Max	Unit	
t_{pd}	propagation delay	A/B to An/Bn or An/Bn to A/B; see Figure 6	[2][3]				
		$V_{CC} = 2.3 \text{ V to } 2.7 \text{ V}$		-	0.25	-	ns
		$V_{CC} = 3.0 \text{ V to } 3.6 \text{ V}$		-	0.25	-	ns
t_{en}	enable time	S to A/B, An/Bn; see Figure 8	[3]				
		$V_{CC} = 2.3 \text{ V to } 2.7 \text{ V}$		-	-	50	ns
		$V_{CC} = 3.0 \text{ V to } 3.6 \text{ V}$		-	-	30	ns
		OE to A/B, An/Bn; see Figure 8	[3]				

Table 9. Dynamic characteristics...continued

At recommended operating conditions; voltages are referenced to GND (ground = 0 V); for test circuit, see [Figure 9](#).

Symbol	Parameter	Conditions	Min	Typ ^[1]	Max	Unit
		$V_{CC} = 2.3\text{ V to }2.7\text{ V}$	-	-	32	ns
		$V_{CC} = 3.0\text{ V to }3.6\text{ V}$	-	-	17	ns
t_{dis}	disable time	S to A/B, An/Bn; see Figure 8	[3]			
		$V_{CC} = 2.3\text{ V to }2.7\text{ V}$	-	-	23	ns
		$V_{CC} = 3.0\text{ V to }3.6\text{ V}$	-	-	12	ns
		\overline{OE} to A/B, An/Bn; see Figure 8	[3]			
		$V_{CC} = 2.3\text{ V to }2.7\text{ V}$	-	-	12	ns
		$V_{CC} = 3.0\text{ V to }3.6\text{ V}$	-	-	10	ns
$t_{sk(o)}$	output skew time	see Figure 7	[4]			
		$V_{CC} = 2.3\text{ V to }2.7\text{ V}$	-	0.1	0.2	ns
		$V_{CC} = 3.0\text{ V to }3.6\text{ V}$	-	0.1	0.2	ns
$t_{sk(p)}$	pulse skew time	see Figure 6	[4]			
		$V_{CC} = 2.3\text{ V to }2.7\text{ V}$	-	0.1	0.2	ns
		$V_{CC} = 3.0\text{ V to }3.6\text{ V}$	-	0.1	0.2	ns

- [1] Typical values are measured at $T_{amb} = 25\text{ °C}$ and $V_{CC} = 2.5\text{ V}$ and 3.3 V respectively.
- [2] The propagation delay is the calculated RC time constant of the typical ON resistance of the switch and the specified load capacitance, when driven by an ideal voltage source (zero output impedance).
- [3] t_{pd} is the same as t_{PLH} and t_{PHL} .
- [4] Guaranteed by design.

11.1 Waveforms, test circuit and graphs

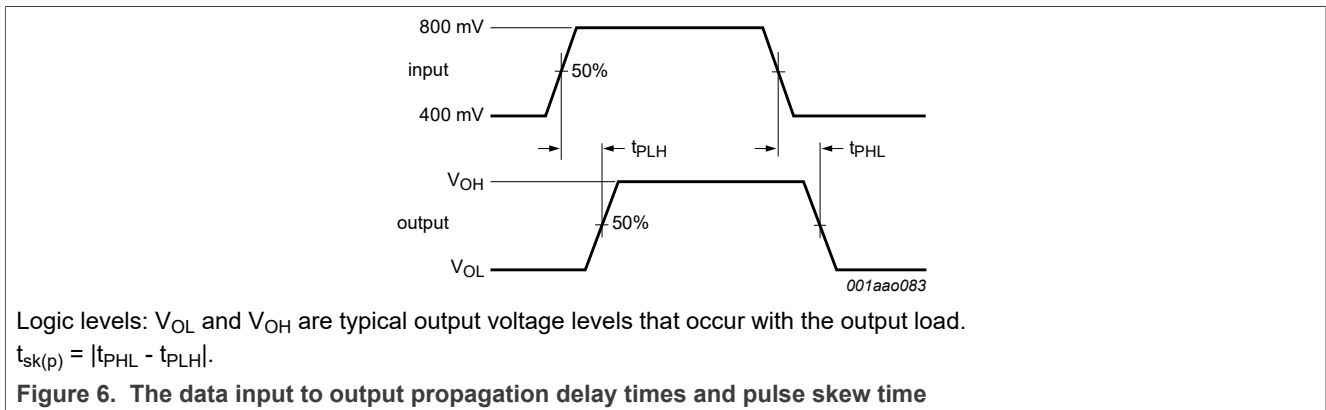

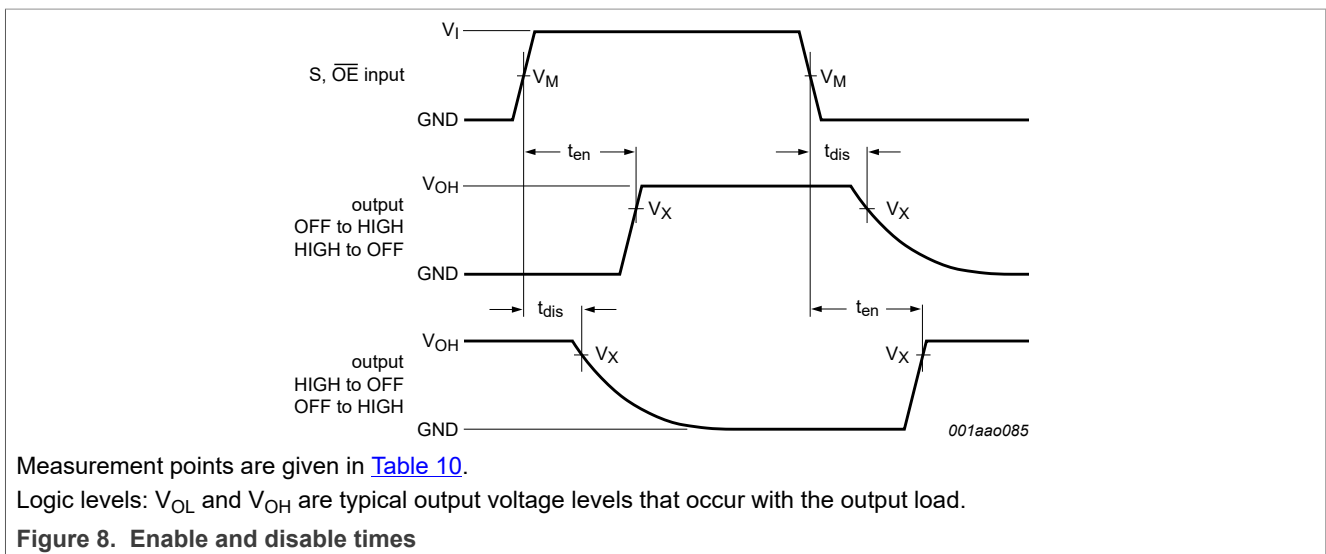
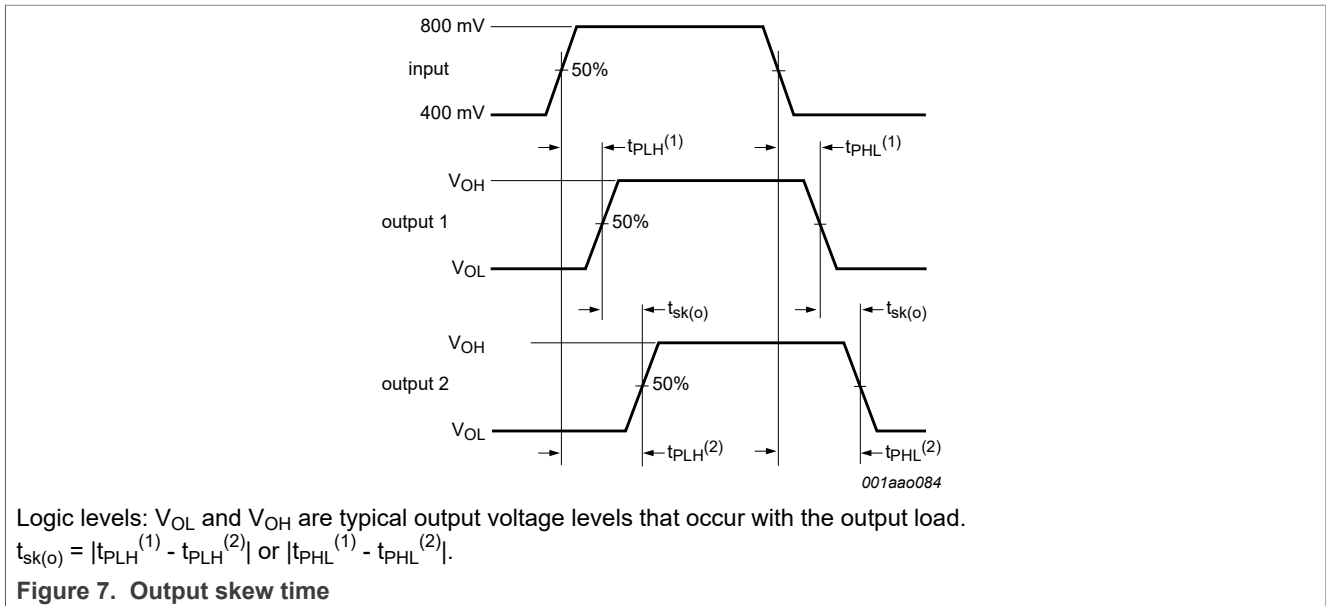
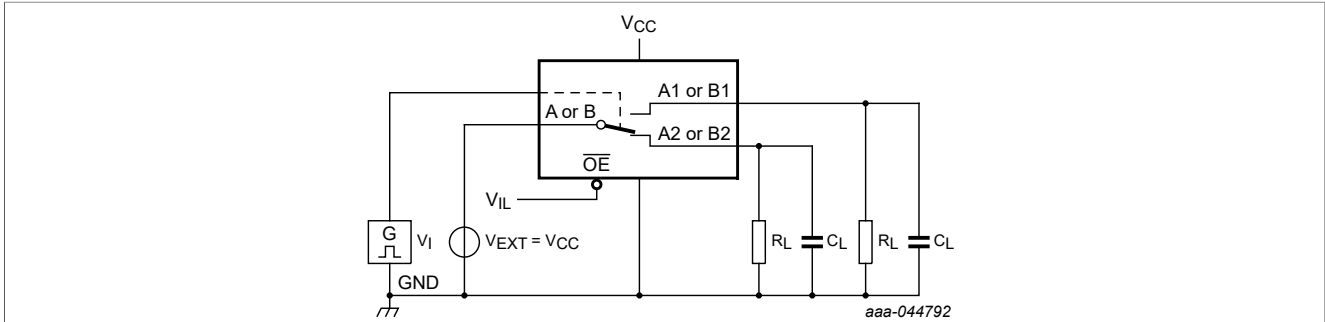

Table 10. Measurement points

Supply voltage	Input		Output
V_{CC}	V_M	V_I	V_X
2.3 V to 3.6 V	$0.5V_I$	1.8 V	$0.9V_{OH}$



Test data is given in [Table 11](#).

Definitions test circuit:

R_L = Load resistance.

C_L = Load capacitance including jig and probe capacitance.

V_{EXT} = External voltage for measuring switching times.

V_I may be connected to S or \overline{OE} .

Figure 9. Test circuit for switching times

Table 11. Test data

Supply voltage	Input		Load	
V_{CC}	V_I	t_r, t_f	C_L	R_L
2.3 V to 3.6 V	1.8 V	≤ 5 ns	50 pF	500 Ω

12 Power supply recommendations

Power to the device is supplied through the V_{CC} pin and should follow the I²C and I3C standards.

NXP recommends placing a bypass capacitor as close as possible to the supply pin V_{CC} to help smooth out lower frequency noise to provide better load regulation across the frequency spectrum.

13 Application information

13.1 Application and implementation: I3C or I²C-bus

Information in the following application section is not part of the NXP component specification, and NXP does not warrant its accuracy or completeness.

NXP's customers are responsible for determining suitability of components for their purposes. Customers should validate and test their design implementation to confirm system functionality.

13.1.1 Application information

There are many I3C or I²C applications where there is the need for a single controller to connect to identical targets to avoid address conflict ([Figure 10](#)) or two controllers to connect to a shared target ([Figure 11](#)).

The P3S0200 acts like a wire that can be switched between the common input (A/B) to the shared output (A1/B1 or A2/B2) and is able to operate at any bus voltage between GND and 5.5 V (e.g., I3C or I²C bus max voltage can be any voltage up to 5.5 V regardless of V_{CC} supply voltage operating between 2.3 V and 3.6 V).

The P3S02000 doesn't provide any voltage level translation between A/B and An/Bn but it will isolate the capacitance for the bus that is not connected to A/B.

13.1.1.1 Typical application (A)

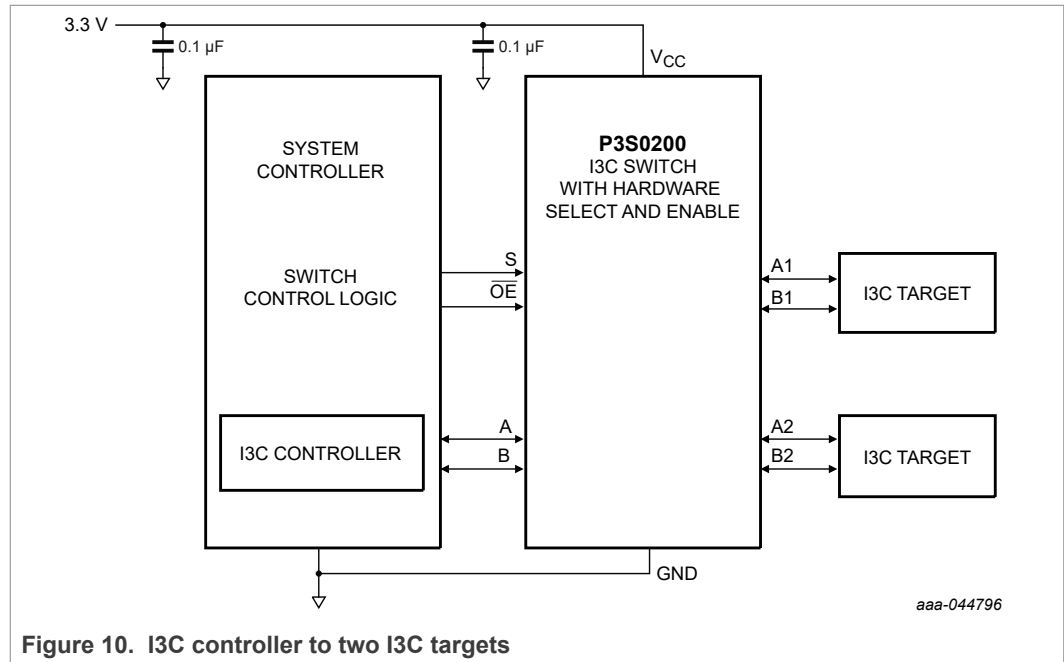

Figure 10. I3C controller to two I3C targets

13.1.1.2 Typical application (B)

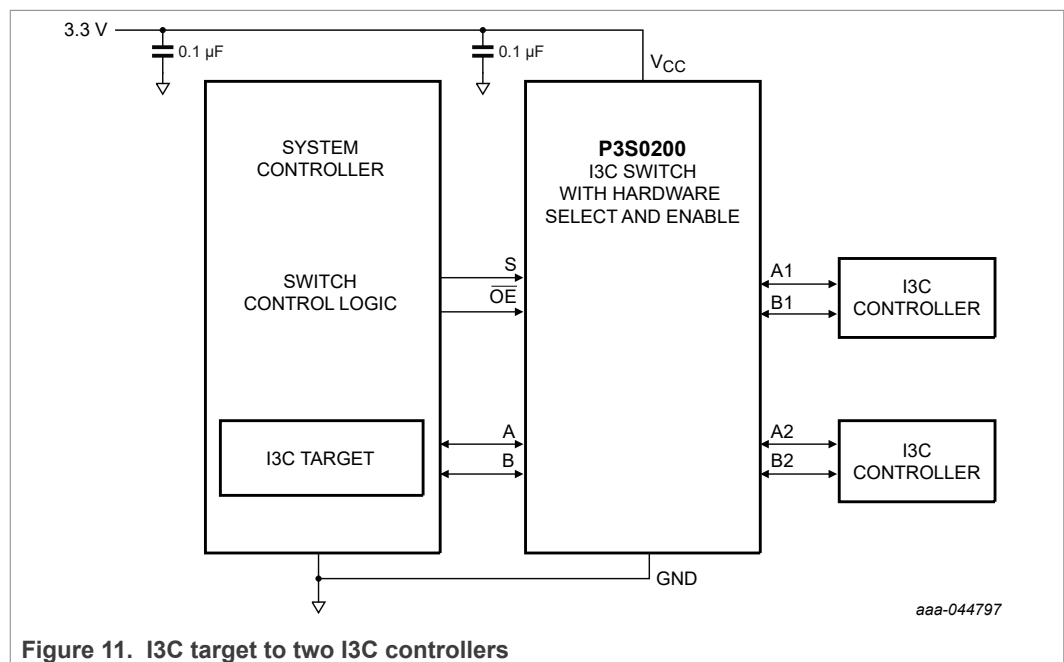

Figure 11. I3C target to two I3C controllers

13.1.2 Design requirements

Design requirements of the I²C and I3C standards should be followed. NXP recommends that the digital control pins S and $\overline{\text{OE}}$ be pulled up to V_{CC} or down to GND to avoid undesired switch positions that could result from the floating pin.

13.1.3 Detailed design procedure

The P3S0200 can be properly operated without any external components. When used for I3C or I²C there will not be any unused pins but if being used for example as single wire mux and using only one channel then it is recommended that unused pins should be connected to ground through a 50 Ω resistor to prevent signal reflections back into the device.

Design requirements of the I²C and I3C standards should be followed. NXP recommends that the digital control pins S and $\overline{\text{OE}}$ be pulled up to V_{CC} or down to GND to avoid undesired switch positions that could result from the floating pin.

13.2 Layout

13.2.1 Layout guidelines

The I3C bus would benefit from these guidelines however the slower 12.5 MHz is much more forgiving if these guidelines can't be followed.

Place supply bypass capacitors as close to V_{CC} pin as possible and avoid placing the bypass caps near the A/B traces.

Route the high-speed I3C signals using a minimum of vias and corners which will reduce signal reflections and impedance changes. When a via must be used, increase the clearance size around it to minimize its capacitance. Each via introduces discontinuities in the signal's transmission line and increases the chance of picking up interference from the other layers of the board. Be careful when designing test points on twisted pair lines; through-hole pins are not recommended.

When it becomes necessary to turn 90°, use two 45° turns or an arc instead of making a single 90° turn. This reduces reflections on the signal traces by minimizing impedance discontinuities. Do not route I3C traces under or near crystals, oscillators, clock signal generators, switching regulators, mounting holes, magnetic devices or ICs that use or duplicate clock signals. Avoid stubs on the high-speed I3C signals because they cause signal reflections.

Route all high-speed I3C signal traces over continuous planes (V_{CC} or GND), with no interruptions.

Avoid crossing over anti-etch, commonly found with plane splits. Due to high frequencies associated with the I3C, a printed circuit board with at least four layers is recommended; two signal layers separated by a ground and power layer as shown in [Figure 12](#).

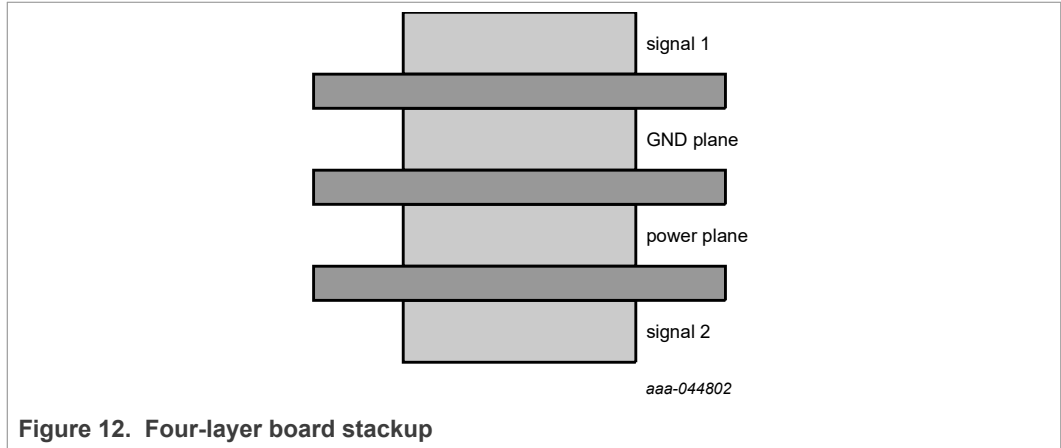

The majority of signal traces should run on a single layer, preferably Signal 1. Immediately next to this layer should be the GND plane, which is solid with no cuts. Avoid running signal traces across a split in the ground or power plane. When running across split planes is unavoidable, sufficient decoupling must be used. Minimizing the number of signal vias reduces EMI by reducing inductance at high frequencies.

13.2.2 Layout example

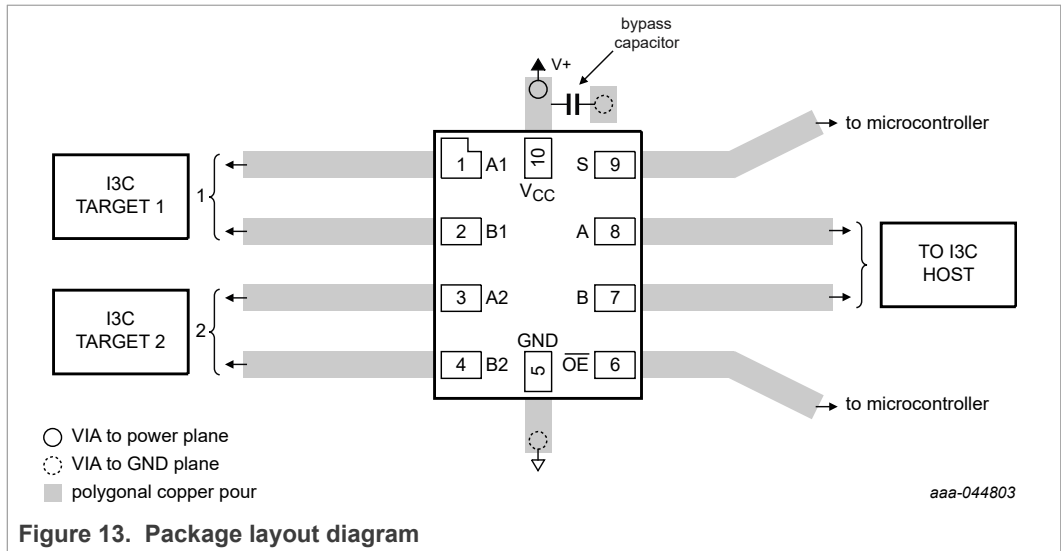

14 Package outline

XQFN10: plastic, extremely thin quad flat package; no leads;
10 terminals; body 1.55 x 2.00 x 0.50 mm

SOT1049-3

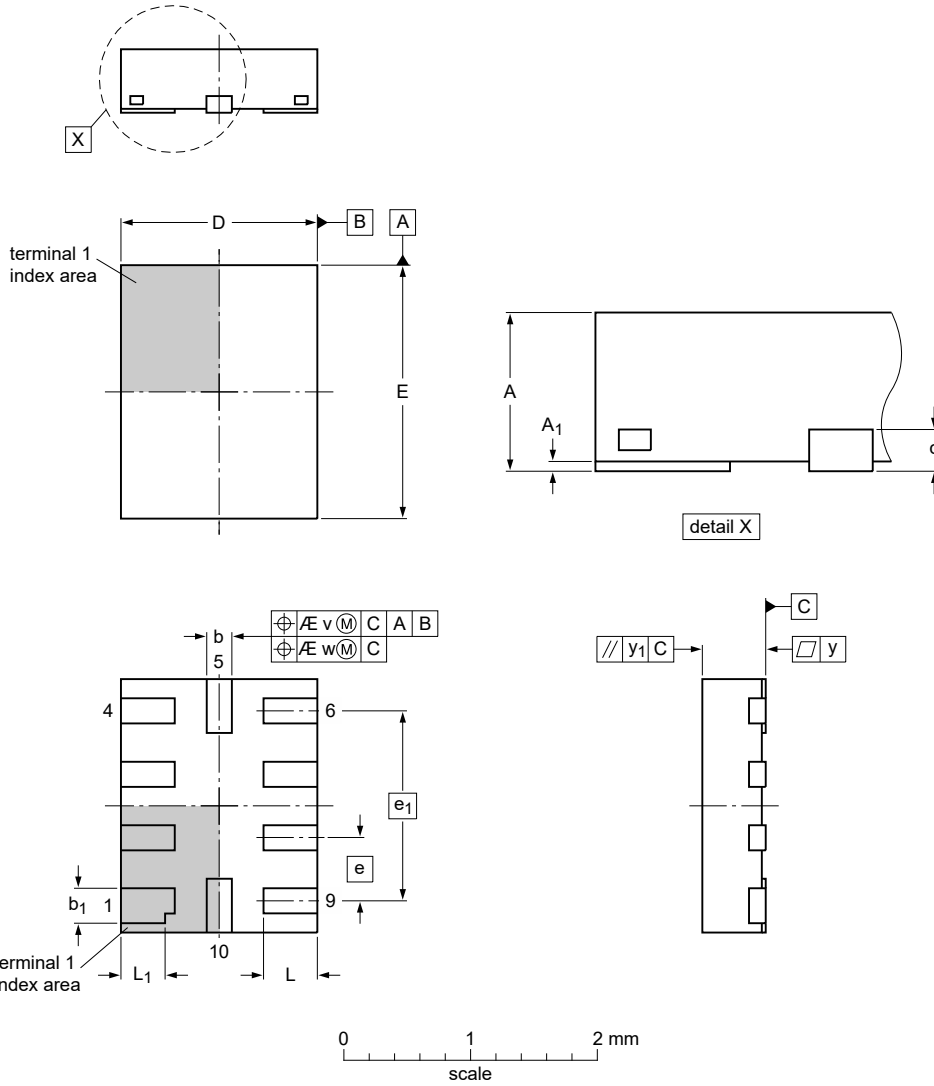

Dimensions

Unit ⁽¹⁾	A	A ₁	b	b ₁	c	D	E	e	e ₁	L	L ₁	v	w	y	y ₁
max	0.5	0.05	0.25	0.33		1.65	2.1			0.48	0.40				
nom			0.20	0.28	0.127	1.55	2.0	0.5	1.5	0.43	0.35	0.1	0.05	0.05	0.05
min		0.00	0.15	0.23		1.45	1.9			0.38	0.30				

Note

1. Plastic or metal protrusions of 0.075 mm maximum per side are not included.

sot1049-3_po

Outline version	References			European projection	Issue date
	IEC	JEDEC	JEITA		
SOT1049-3	---	MO255	---		10-12-06 11-03-30

Figure 14. Package outline SOT1049-3 (XQFN10)

15 Abbreviations

Table 12. Abbreviations

Acronym	Description
CDM	Charged Device Model
CMOS	Complementary Metal Oxide Semiconductor
ESD	ElectroStatic Discharge
HBM	Human Body Model
MM	Machine Model

16 Revision history

Table 13. Revision history

Document ID	Release date	Data sheet status	Change notice	Supersedes
P3S0200 v1.0	20220214	Product data sheet	-	-

17 Legal information

17.1 Data sheet status

Document status ^{[1][2]}	Product status ^[3]	Definition
Objective [short] data sheet	Development	This document contains data from the objective specification for product development.
Preliminary [short] data sheet	Qualification	This document contains data from the preliminary specification.
Product [short] data sheet	Production	This document contains the product specification.

[1] Please consult the most recently issued document before initiating or completing a design.

[2] The term 'short data sheet' is explained in section "Definitions".

[3] The product status of device(s) described in this document may have changed since this document was published and may differ in case of multiple devices. The latest product status information is available on the Internet at URL <http://www.nxp.com>.

17.2 Definitions

Draft — A draft status on a document indicates that the content is still under internal review and subject to formal approval, which may result in modifications or additions. NXP Semiconductors does not give any representations or warranties as to the accuracy or completeness of information included in a draft version of a document and shall have no liability for the consequences of use of such information.

Short data sheet — A short data sheet is an extract from a full data sheet with the same product type number(s) and title. A short data sheet is intended for quick reference only and should not be relied upon to contain detailed and full information. For detailed and full information see the relevant full data sheet, which is available on request via the local NXP Semiconductors sales office. In case of any inconsistency or conflict with the short data sheet, the full data sheet shall prevail.

Product specification — The information and data provided in a Product data sheet shall define the specification of the product as agreed between NXP Semiconductors and its customer, unless NXP Semiconductors and customer have explicitly agreed otherwise in writing. In no event however, shall an agreement be valid in which the NXP Semiconductors product is deemed to offer functions and qualities beyond those described in the Product data sheet.

17.3 Disclaimers

Limited warranty and liability — Information in this document is believed to be accurate and reliable. However, NXP Semiconductors does not give any representations or warranties, expressed or implied, as to the accuracy or completeness of such information and shall have no liability for the consequences of use of such information. NXP Semiconductors takes no responsibility for the content in this document if provided by an information source outside of NXP Semiconductors.

In no event shall NXP Semiconductors be liable for any indirect, incidental, punitive, special or consequential damages (including - without limitation - lost profits, lost savings, business interruption, costs related to the removal or replacement of any products or rework charges) whether or not such damages are based on tort (including negligence), warranty, breach of contract or any other legal theory.

Notwithstanding any damages that customer might incur for any reason whatsoever, NXP Semiconductors' aggregate and cumulative liability towards customer for the products described herein shall be limited in accordance with the Terms and conditions of commercial sale of NXP Semiconductors.

Right to make changes — NXP Semiconductors reserves the right to make changes to information published in this document, including without limitation specifications and product descriptions, at any time and without notice. This document supersedes and replaces all information supplied prior to the publication hereof.

Suitability for use — NXP Semiconductors products are not designed, authorized or warranted to be suitable for use in life support, life-critical or safety-critical systems or equipment, nor in applications where failure or malfunction of an NXP Semiconductors product can reasonably be expected to result in personal injury, death or severe property or environmental damage. NXP Semiconductors and its suppliers accept no liability for inclusion and/or use of NXP Semiconductors products in such equipment or applications and therefore such inclusion and/or use is at the customer's own risk.

Applications — Applications that are described herein for any of these products are for illustrative purposes only. NXP Semiconductors makes no representation or warranty that such applications will be suitable for the specified use without further testing or modification.

Customers are responsible for the design and operation of their applications and products using NXP Semiconductors products, and NXP Semiconductors accepts no liability for any assistance with applications or customer product design. It is customer's sole responsibility to determine whether the NXP Semiconductors product is suitable and fit for the customer's applications and products planned, as well as for the planned application and use of customer's third party customer(s). Customers should provide appropriate design and operating safeguards to minimize the risks associated with their applications and products.

NXP Semiconductors does not accept any liability related to any default, damage, costs or problem which is based on any weakness or default in the customer's applications or products, or the application or use by customer's third party customer(s). Customer is responsible for doing all necessary testing for the customer's applications and products using NXP Semiconductors products in order to avoid a default of the applications and the products or of the application or use by customer's third party customer(s). NXP does not accept any liability in this respect.

Limiting values — Stress above one or more limiting values (as defined in the Absolute Maximum Ratings System of IEC 60134) will cause permanent damage to the device. Limiting values are stress ratings only and (proper) operation of the device at these or any other conditions above those given in the Recommended operating conditions section (if present) or the Characteristics sections of this document is not warranted. Constant or repeated exposure to limiting values will permanently and irreversibly affect the quality and reliability of the device.

Terms and conditions of commercial sale — NXP Semiconductors products are sold subject to the general terms and conditions of commercial sale, as published at <http://www.nxp.com/profile/terms>, unless otherwise agreed in a valid written individual agreement. In case an individual agreement is concluded only the terms and conditions of the respective agreement shall apply. NXP Semiconductors hereby expressly objects to applying the customer's general terms and conditions with regard to the purchase of NXP Semiconductors products by customer.

No offer to sell or license — Nothing in this document may be interpreted or construed as an offer to sell products that is open for acceptance or the grant, conveyance or implication of any license under any copyrights, patents or other industrial or intellectual property rights.

Quick reference data — The Quick reference data is an extract of the product data given in the Limiting values and Characteristics sections of this document, and as such is not complete, exhaustive or legally binding.

Export control — This document as well as the item(s) described herein may be subject to export control regulations. Export might require a prior authorization from competent authorities.

Suitability for use in non-automotive qualified products — Unless this data sheet expressly states that this specific NXP Semiconductors product is automotive qualified, the product is not suitable for automotive use. It is neither qualified nor tested in accordance with automotive testing or application requirements. NXP Semiconductors accepts no liability for inclusion and/or use of non-automotive qualified products in automotive equipment or applications.

In the event that customer uses the product for design-in and use in automotive applications to automotive specifications and standards, customer (a) shall use the product without NXP Semiconductors' warranty of the product for such automotive applications, use and specifications, and (b) whenever customer uses the product for automotive applications beyond NXP Semiconductors' specifications such use shall be solely at customer's own risk, and (c) customer fully indemnifies NXP Semiconductors for any liability, damages or failed product claims resulting from customer design and use of the product for automotive applications beyond NXP Semiconductors' standard warranty and NXP Semiconductors' product specifications.

Translations — A non-English (translated) version of a document, including the legal information in that document, is for reference only. The English version shall prevail in case of any discrepancy between the translated and English versions.

Security — Customer understands that all NXP products may be subject to unidentified vulnerabilities or may support established security standards or specifications with known limitations. Customer is responsible for the design and operation of its applications and products throughout their lifecycles to reduce the effect of these vulnerabilities on customer's applications and products. Customer's responsibility also extends to other open and/or proprietary technologies supported by NXP products for use in customer's applications. NXP accepts no liability for any vulnerability. Customer should regularly check security updates from NXP and follow up appropriately.

Customer shall select products with security features that best meet rules, regulations, and standards of the intended application and make the ultimate design decisions regarding its products and is solely responsible for compliance with all legal, regulatory, and security related requirements concerning its products, regardless of any information or support that may be provided by NXP.

NXP has a Product Security Incident Response Team (PSIRT) (reachable at PSIRT@nxp.com) that manages the investigation, reporting, and solution release to security vulnerabilities of NXP products.

17.4 Trademarks

Notice: All referenced brands, product names, service names, and trademarks are the property of their respective owners.

NXP — wordmark and logo are trademarks of NXP B.V.

Tables

Tab. 1.	Ordering information	1	Tab. 8.	ON resistance	5
Tab. 2.	Ordering options	2	Tab. 9.	Dynamic characteristics	6
Tab. 3.	Pin description	3	Tab. 10.	Measurement points	8
Tab. 4.	Function table	3	Tab. 11.	Test data	9
Tab. 5.	Limiting values	3	Tab. 12.	Abbreviations	14
Tab. 6.	Recommended operating conditions	4	Tab. 13.	Revision history	14
Tab. 7.	Static characteristics	4			

Figures

Fig. 1.	Logic symbol	2	Fig. 7.	Output skew time	8
Fig. 2.	Pin configuration SOT1049-3 (XQFN10)	2	Fig. 8.	Enable and disable times	8
Fig. 3.	Test circuit for measuring OFF-state leakage current	5	Fig. 9.	Test circuit for switching times	9
Fig. 4.	Test circuit for measuring ON resistance	6	Fig. 10.	I3C controller to two I3C targets	10
Fig. 5.	ON resistance as a function of input voltage	6	Fig. 11.	I3C target to two I3C controllers	10
Fig. 6.	The data input to output propagation delay times and pulse skew time	7	Fig. 12.	Four-layer board stackup	12
			Fig. 13.	Package layout diagram	12
			Fig. 14.	Package outline SOT1049-3 (XQFN10)	13

Contents

1	General description	1
2	Features and benefits	1
3	Applications	1
4	Ordering information	1
4.1	Ordering options	2
5	Functional diagram	2
6	Pinning information	2
6.1	Pinning	2
6.2	Pin description	3
7	Functional description	3
8	Limiting values	3
9	Recommended operating conditions	4
10	Static characteristics	4
10.1	Test circuits	5
10.2	ON resistance	5
10.3	ON resistance test circuit and waveforms	6
11	Dynamic characteristics	6
11.1	Waveforms, test circuit and graphs	7
12	Power supply recommendations	9
13	Application information	9
13.1	Application and implementation: I3C or I2C- bus	9
13.1.1	Application information	9
13.1.1.1	Typical application (A)	10
13.1.1.2	Typical application (B)	10
13.1.2	Design requirements	11
13.1.3	Detailed design procedure	11
13.2	Layout	11
13.2.1	Layout guidelines	11
13.2.2	Layout example	12
14	Package outline	13
15	Abbreviations	14
16	Revision history	14
17	Legal information	15

Please be aware that important notices concerning this document and the product(s) described herein, have been included in section 'Legal information'.

© NXP B.V. 2022.

All rights reserved.



For more information, please visit: <http://www.nxp.com>

For sales office addresses, please send an email to: salesaddresses@nxp.com

Date of release: 14 February 2022
Document identifier: P3S0200

Looking for pricing, stock, or lifecycle information?

Click below to explore more details on WIN SOURCE:

-  [View P3S0200GMX on WIN SOURCE](#)
-  [NXP / Nexperia Information](#)

Optimize Your Supply Chain with WIN SOURCE Solutions

-  Global Sourcing Solution
-  Obsolete Management
-  Cost Control Management
-  Shortage Management
-  Alternative Solution
-  Excess Inventory Management