

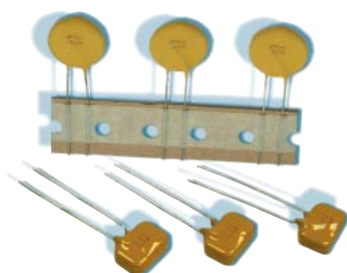

**THE DATASHEET OF
HVR600P160CF**



No. HVR600



High Voltage PTC Device, 60 V / 600 V

Standard
UL 1434 1st Edition
CSA C22.2 No. 0 CSA TIL No. CA-3A

Approvals
cULus Recognition
TÜV

Features

This product line is designed to provide protection against induced AC power current, direct power contact and the natural lightning strike. The HVR600 product line is widely used in the field of telecommunications and networking, ISDN and XSDN equipment. It also helps equipment manufacturers pass ITU K20, K21 and telcordia requirements.

Specifications

Packaging

A: bulk
F: tape and ammo

Materials

Insulating Material: Yellow Epoxy Polymer, UL 94V0

Round Pins: Copper alloy, tin plated

Max. Device Surface Temperature in Tripped State
125 °C

Operating / Storage Temperature

-40 °C to +85 °C (consider de-rating)

Humidity Ageing

+85 °C, 85 % R.H., 1000 hours, ± 5 % typical resistance change

Soldering Characteristics

Solderability per MIL-STD-202, Method 208E

Thermal Shock

MIL-STD-202F, Method 107G

+125 °C to -40 °C 10 times, ±5 % typical resistance change

Solvent Resistance

MIL-STD-202, Method 215F, no change

Marking

"P", voltage, amperage rating, lot number

Dimensions (mm)

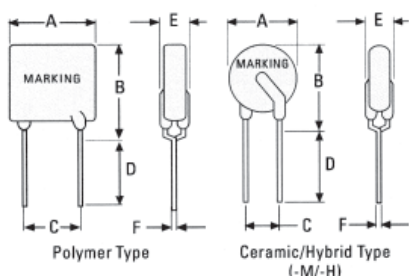

Devices are not intended for continuous use at 250 V / 600 V!



Dimensions (mm)									
Model	A	B	C	D	E	Physical Characteristics		packaging quantity	
	Max	Max	typ	Min	Max	Lead	Material	bag	ammo
HVR600P150C	13,5	12,6	5,1	4,7	6,0	0.65 dia	Sn/Cu	200	600
HVR600P150C-RA	13,5	12,6	5,1	4,7	6,0	0.65 dia	Sn/Cu	200	600
HVR600P150C-RB	13,5	12,6	5,1	4,7	6,0	0.65 dia	Sn/Cu	200	600
HVR600P150CF	13,5	12,6	5,1	4,7	6,0	0.65 dia	Sn/Cu	200	600
HVR600P160C	16,0	12,6	5,1	4,7	6,0	0.65 dia	Sn/Cu	200	500
HVR600P160C-RA	16,0	12,6	5,1	4,7	6,0	0.65 dia	Sn/Cu	200	500
HVR600P160C-R1	16,0	12,6	5,1	4,7	6,0	0.65 dia	Sn/Cu	200	500
HVR600P160CF	16,0	12,6	5,1	4,7	6,0	0.65 dia	Sn/Cu	200	500

Permissible continuous operating current is ≤ 100 % at ambient temperature of 20 °C (68 °F).											
Model	I _{hold}	I _{Trip} (A)	V _{max.} V _{int/AC} /V _{op/DC} *	I _{max.} (A)	max. time to trip (s @ A)	P _{d max.} (W)	Resistance			Approvals	
							R _{min.} ()	R _{max.} ()	R _{I max.} ()	cURus	TÜV
HVR600P150C	0.15	0.30	600/60	3	5.00 @ 1.00	1.00	6.0	12.0	22.0	•	•
HVR600P150C-RA	0.15	0.30	600/60	3	5.00 @ 1.00	1.00	7.0	10.0	20.0	•	•
HVR600P150C-RB	0.15	0.30	600/60	3	4.50 @ 1.00	1.00	9.0	12.0	22.0	•	•
HVR600P150CF	0.15	0.30	600/60	3	5.00 @ 1.00	1.00	6.0	12.0	22.0	•	•
HVR600P160C	0.16	0.32	600/60	3	7.00 @ 1.00	1.00	4.0	10.0	18.0	•	•
HVR600P160C-RA	0.16	0.32	600/60	3	9.50 @ 1.00	1.00	4.0	7.0	16.0	•	•
HVR600P160C-R1	0.16	0.32	600/60	3	9.00 @ 1.00	1.00	4.0	8.0	17.0	•	•
HVR600P160CF	0.16	0.32	600/60	3	7.00 @ 1.00	1.00	4.0	10.0	18.0	•	•

* V_{int} : Interrupt Voltage V_{op} : Operating Voltage (V dc)

NOTE:
 I_{hold} = Hold current: maximum current device will pass without tripping in 20 °C still air.
 I_{trip} = Trip current: minimum current at which the device will trip in 20 °C still air.
 I_{max} = Maximum fault current device can withstand without damage at rated voltage (V_{max})
 P_d = Power dissipated from device when in the tripped state at 20°C still air.
 R_{min} = Minimum resistance of device in initial (un-soldered) state.
 R_{I max} = Maximum resistance of device at 20°C measured one hour after tripping for 20 sec.
 Caution: Operation beyond the specified rating may result in damage and possible arcing and flame.

Order Information

Qty.	Order-Number	Model	Packaging

Specifications are subject to change without notice.

No. HVR600

Average time-current curve

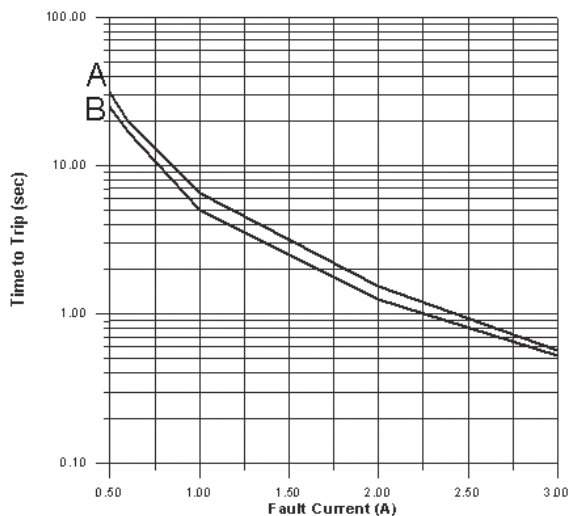

A : HVR600P160F
B : HVR600P150F

Agency Specification

Product	Lightning	Power Cross
HVR600P150C	FCC part 68 - 1.0 kV 10/160 μ s 800 V 10/560 μ s Telcordia GR - 1089 - 1.0 kV 10/1000 μ s	UL60950, 3rd ed. - 600 V ac, 40 A
HVR600P160C		Telcordia GR - 1089 - 600 V ac, 60 A
HVR600P150CF		select a specific part number for each application based on the agency request
HVR160CF		

Part-numbering system

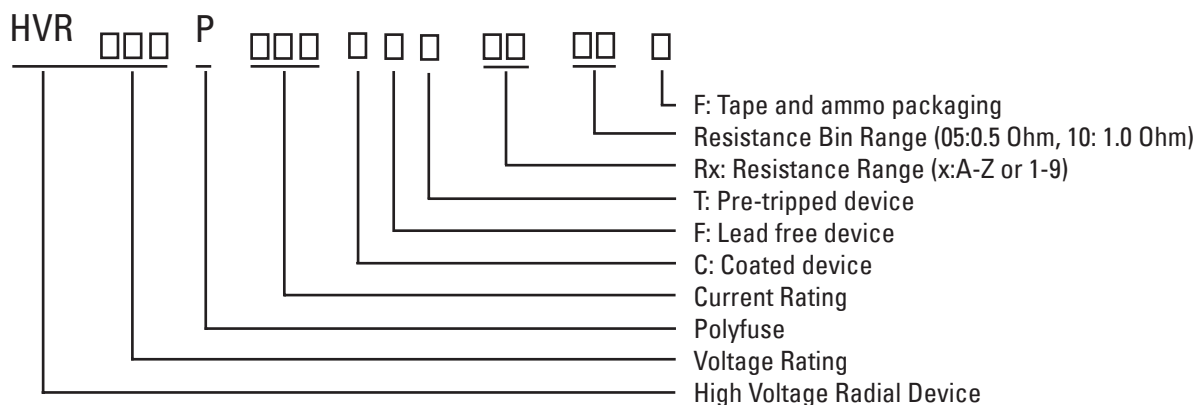



Thermal Derating Chart

Model	Ambient Operation Temperature - I_{hold} (A)						
	-40 °C	-20 °C	0 °C	23 °C	40 °C	60 °C	85 °C
HVR600P150C	0.23	0.21	0.18	0.15	0.12	0.10	0.06
HVR600P160C	0.24	0.22	0.19	0.16	0.13	0.12	0.07
HVR600P150CF	0.23	0.21	0.18	0.15	0.12	0.10	0.06
HVR600P160CF	0.24	0.22	0.19	0.16	0.13	0.12	0.07

Looking for pricing, stock, or lifecycle information?

Click below to explore more details on WIN SOURCE:

-  [View HVR600P160CF on WIN SOURCE](#)
-  [Littelfuse Inc. Information](#)

Optimize Your Supply Chain with WIN SOURCE Solutions

-  Global Sourcing Solution
-  Obsolete Management
-  Cost Control Management
-  Shortage Management
-  Alternative Solution
-  Excess Inventory Management