



SIM/Smart Card Level Translators in μ MAX

MAX1740/MAX1741

General Description

The MAX1740/MAX1741 subscriber identity module (SIM)/smart card level translators provide level shifting and electrostatic discharge (ESD) protection for SIM and smart card ports. These devices integrate two unidirectional level shifters for the reset and clock signals, a bidirectional level shifter for the serial data stream, and $\pm 10\text{kV}$ ESD protection on all card contacts.

The MAX1740 includes a $\overline{\text{SHDN}}$ control input to aid insertion and removal of SIM and smart cards, while the MAX1741 includes a system-side data driver to support system controllers without open-drain outputs. The logic supply voltage range is +1.425V to +5.5V for the "controller side" and +2.25V to +5.5V for the "card side." Total supply current is 2.5 μA max. Both devices automatically shut down when either power supply is removed. For a complete SIM-card interface, combine the MAX1740/MAX1741 with the MAX1686H 0V/3V/5V regulated charge pump.

The MAX1740/MAX1741 are available in ultra-small 10-pin μ MAX packages that are only 1.09mm high and half the area of an 8-pin SO.

The MAX1740/MAX1741 are compliant with GSM test specifications 11.11 and 11.12.

Applications

- SIM Interface in GSM Cellular Telephones
- Smart Card Readers
- Logic Level Translation
- SPI™/QSPI™/MICROWIRE™ Level Translation

Typical Operating Circuit

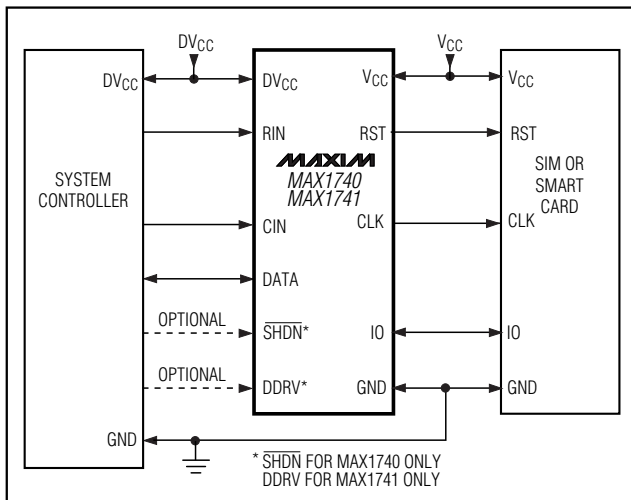

Features

- ◆ SIM/Smart Card Level Shifting
- ◆ $\pm 10\text{kV}$ ESD Card Socket Protection
- ◆ Allows Level Translation with $DV_{CC} \geq V_{CC}$ or $DV_{CC} \leq V_{CC}$
- ◆ Automatically Shuts Down When Either Supply Is Removed
- ◆ Card Contacts Actively Pulled Low During Shutdown
- ◆ +1.425V to +5.5V Controller Voltage Range
- ◆ +2.25V to +5.5V Card Voltage Range
- ◆ 2.5 μA (max) Total Quiescent Supply Current
- ◆ 0.01 μA Total Shutdown Supply Current
- ◆ Ultra-Small 10-Pin μ MAX Package
- ◆ Compliant with GSM Test Specifications 11.11 and 11.12

Ordering Information

PART	TEMP. RANGE	PIN-PACKAGE
MAX1740EUB	-40°C to +85°C	10 μ MAX
MAX1741EUB	-40°C to +85°C	10 μ MAX

Pin Configuration

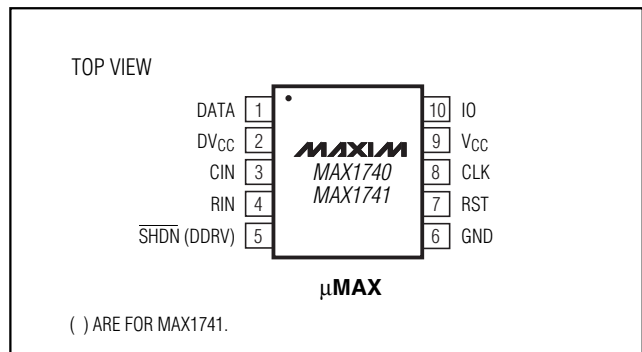

SPI and QSPI are trademarks of Motorola, Inc.
MICROWIRE is a trademark of National Semiconductor Corp.



SIM/Smart Card Level Translators in μ MAX

ABSOLUTE MAXIMUM RATINGS

DV _{CC} , V _{CC} to GND.....	-0.3V to +6.0V	Operating Temperature Range	-40°C to +85°C
RIN, CIN, DATA, DDRV, SHDN to GND	-0.3V to (DV _{CC} + 0.3V)	Storage Temperature Range	-65°C to +150°C
RST, CLK, IO to GND	-0.3V to (V _{CC} + 0.3V)	Junction Temperature	+150°C
Continuous Power Dissipation (T _A = +70°C)		Lead Temperature (soldering, 10s)	+300°C
10-Pin μ MAX (derate 5.6mW/°C above +70°C)	444mW		

Stresses beyond those listed under "Absolute Maximum Ratings" may cause permanent damage to the device. These are stress ratings only, and functional operation of the device at these or any other conditions beyond those indicated in the operational sections of the specifications is not implied. Exposure to absolute maximum rating conditions for extended periods may affect device reliability.

ELECTRICAL CHARACTERISTICS

(Figure 1, DV_{CC} = +1.8V, V_{CC} = +3.0V or +5.0V, $\overline{\text{SHDN}}$ = DV_{CC}, CIN = RIN = GND or DV_{CC}, IO = V_{CC}, DATA = DDRV = DV_{CC}, C_{IO} = C_{CLK} = C_{RST} = C_{DATA} = 30pF, T_A = 0°C to +85°C, unless otherwise noted. Typical values are at T_A = +25°C.)

PARAMETER	SYMBOL	CONDITIONS	MIN	TYP	MAX	UNITS
POWER SUPPLIES						
DV _{CC} Operating Range	DV _{CC}		1.425		5.5	V
V _{CC} Operating Range	V _{CC}		2.25		5.5	V
DV _{CC} Operating Current	IDV _{CC}	CIN static			1	μ A
		CIN clocked at 1.625MHz from GND to DV _{CC} with 50% duty cycle		8		
		CIN clocked at 3.25MHz from GND to DV _{CC} with 50% duty cycle		16		
V _{CC} Operating Current	IV _{CC}	CIN static			1.5	μ A
		CIN clocked at 1.625MHz from GND to DV _{CC} with 50% duty cycle		0.5		mA
		CIN clocked at 3.25MHz from GND to DV _{CC} with 50% duty cycle		1		
Total Shutdown Current	ISHDN	I _{OFF} = IV _{CC} + IDV _{CC} , $\overline{\text{SHDN}}$ = GND (MAX1740 only), or DV _{CC} = GND or V _{CC} = GND		0.01	2	μ A
CIN, RIN, SHDN, DDRV LOGIC INPUTS						
Digital Input Low Threshold	V _{IL}		0.2 · DV _{CC}			V
Digital Input High Threshold	V _{IH}		0.7 · DV _{CC}			V
Input Leakage Current			0.01	1		μ A
CLK, RST OUTPUTS						
Digital Output Low Level	V _{OL}	I _{SINK} = 200 μ A		0.4		V
Digital Output High Level	V _{OH}	I _{SOURCE} = 20 μ A	0.9 · V _{CC}			V
		I _{SOURCE} = 200 μ A	0.8 · V _{CC}			
DATA INPUT/OUTPUT						
DATA Pull-Up Resistance	R _{DATA}	Between DATA and DV _{CC}	13	20	28	k Ω
Input Low Threshold	V _{IL} (DATA)	(Note 1)	0.3			V
Input High Threshold	V _{IH} (DATA)	(Note 2)	DV _{CC} - 0.6			V
Input Low Current	I _{IL}	V _{CC} = 5.0V		1		mA
Input High Current	I _{IH}			2		μ A

SIM/Smart Card Level Translators in μ MAX

MAX1740/MAX1741

ELECTRICAL CHARACTERISTICS (continued)

(Figure 1, $DV_{CC} = +1.8V$, $V_{CC} = +3.0V$ or $+5.0V$, $\overline{SHDN} = DV_{CC}$, $C_{IN} = R_{IN} = GND$ or DV_{CC} , $IO = V_{CC}$, $DATA = DDRV = DV_{CC}$, $C_{IO} = C_{CLK} = C_{RST} = C_{DATA} = 30pF$, $T_A = 0^{\circ}C$ to $+85^{\circ}C$, unless otherwise noted. Typical values are at $T_A = +25^{\circ}C$.)

PARAMETER	SYMBOL	CONDITIONS	MIN	TYP	MAX	UNITS
Output Low Level	$V_{OL(DATA)}$	$IO = GND$, $I_{SINK} = 100\mu A$			0.4	V
		$DV_{CC} = 3.0V$, $IO = GND$, $I_{SINK} = 200\mu A$			0.4	V
Output High Level	$V_{OH(DATA)}$	$I_{SOURCE} = 10\mu A$	$0.7 \cdot DV_{CC}$			V
		$DV_{CC} = 3.0V$, $I_{SOURCE} = 20\mu A$	$0.7 \cdot DV_{CC}$			V
IO INPUT/OUTPUT						
IO Pull-Up Resistance	R_{IO}	Between IO and V_{CC}	6.5	10	14	$k\Omega$
Input Low Threshold	$V_{IL(IO)}$	$I_{IL(MAX)} = 1mA$ (Note 1)	0.3			V
Input High Threshold	$V_{IH(IO)}$	$I_{IH(MAX)} = \pm 20\mu A$ (Note 2)		$0.7 \cdot V_{CC}$		V
Input Low Current	I_{IL}				1	mA
Input High Current	I_{IH}				20	μA
Output Low Level	$V_{OL(IO)}$	$DATA = GND$ or $DDRV = GND$, $I_{SINK} = 200\mu A$			0.4	V
Output High Level	$V_{OH(IO)}$	$I_{SOURCE} = 20\mu A$	$0.8 \cdot V_{CC}$			V
SHUTDOWN OUTPUT LEVELS						
Shutdown Output Levels (IO, CLK, RST)		$I_{SINK} = 200\mu A$, $\overline{SHDN} = GND$, $DATA = C_{IN} = R_{IN} = DV_{CC}$ (MAX1740 only)			0.4	V
		$I_{SINK} = 200\mu A$, $DV_{CC} = GND$, \overline{SHDN} (MAX1740) = $DDRV$ (MAX1741) = $DATA = C_{IN} = R_{IN} = DV_{CC}$			0.4	V
		$I_{SINK} = 200\mu A$, $V_{CC} = GND$, \overline{SHDN} (MAX1740) = $DDRV$ (MAX1741) = $DATA = C_{IN} = R_{IN} = DV_{CC}$			0.4	V
TIMING						
Maximum CLK Frequency (Notes 3, 4)	f_{CLK}	$V_{CC} = 2.7V$ to $5.5V$	$DV_{CC} = 2.7V$	5		MHz
			$DV_{CC} = 2.25V$	5		
			$DV_{CC} = 1.7V$	5		
		$V_{CC} = 2.25V$ to $3.6V$	$DV_{CC} = 1.425V$	3.5		
			$DV_{CC} = 2.25V$	4		
			$DV_{CC} = 1.7V$	4		
		$DV_{CC} = 1.425V$	3.5			

SIM/Smart Card Level Translators in μ MAX

ELECTRICAL CHARACTERISTICS

(Figure 1, $DV_{CC} = +1.8V$, $V_{CC} = +3.0V$ or $+5.0V$, $\overline{SHDN} = DV_{CC}$, $CIN = RIN = GND$ or DV_{CC} , $IO = V_{CC}$, $DATA = DDRV = DV_{CC}$, $CIO = CCLK = CRST = CDATA = 30pF$, $T_A = -40^{\circ}C$ to $+85^{\circ}C$, unless otherwise noted.) (Note 5)

PARAMETER	SYMBOL	CONDITIONS	MIN	MAX	UNITS
POWER SUPPLIES					
DV_{CC} Operating Range	DV_{CC}		1.425	5.5	V
V_{CC} Operating Range	V_{CC}		2.25	5.5	V
DV_{CC} Operating Current	$I_{DV_{CC}}$	CIN static		1	μA
V_{CC} Operating Current	$I_{V_{CC}}$	CIN static		1.5	μA
Total Shutdown Current	I_{OFF}	$I_{OFF} = I_{V_{CC}} + I_{DV_{CC}}$, $\overline{SHDN} = GND$ (MAX1740 only), or $DV_{CC} = GND$ or $V_{CC} = GND$		2	μA
CIN, RIN, \overline{SHDN}, DDRV LOGIC INPUTS					
Digital Input Low Threshold	V_{IL}		$0.2 \cdot DV_{CC}$		V
Digital Input High Threshold	V_{IH}			$0.75 \cdot DV_{CC}$	V
Input Leakage Current				1	μA
CLK, RST OUTPUTS					
Digital Output Low Level	V_{OL}	$I_{SINK} = 200\mu A$		0.4	V
Digital Output High Level	V_{OH}	$I_{SOURCE} = 20\mu A$	$0.9 \cdot V_{CC}$		V
		$I_{SOURCE} = 200\mu A$	$0.8 \cdot V_{CC}$		
DATA INPUT/OUTPUT					
DATA Pull-Up Resistance	R_{DATA}	Between DATA and DV_{CC}	13	28	$k\Omega$
Input Low Threshold	$V_{IL(DATA)}$	(Note 1)	0.3		V
Input High Threshold	$V_{IH(DATA)}$	(Note 2)		$DV_{CC} - 0.6$	V
Input Low Current	I_{IL}	$V_{CC} = 5.0V$		1	mA
Input High Current	I_{IH}			2	μA
Output Low Level	$V_{OL(DATA)}$	$IO = GND$, $I_{SINK} = 100\mu A$		0.4	V
		$DV_{CC} = 3.0V$, $IO = GND$, $I_{SINK} = 200\mu A$		0.4	V
Output High Level	$V_{OH(DATA)}$	$I_{SOURCE} = 10\mu A$	$0.7 \cdot DV_{CC}$		V
		$DV_{CC} = 3.0V$, $I_{SOURCE} = 20\mu A$	$0.7 \cdot DV_{CC}$		V
IO INPUT/OUTPUT					
IO Pull-Up Resistance	R_{IO}	Between IO and V_{CC}	6.5	14	$k\Omega$
Input Low Threshold	$V_{IL(IO)}$	$I_{IL(MAX)} = 1mA$ (Note 1)	0.3		V
Input High Threshold	$V_{IH(IO)}$	$I_{IH(MAX)} = \pm 20\mu A$ (Note 2)		$0.7 \cdot V_{CC}$	V
Input Low Current	I_{IL}			1	mA
Input High Current	I_{IH}			20	μA
Output Low Level	$V_{OL(IO)}$	$DATA = GND$ or $DDRV = GND$, $I_{SINK} = 200\mu A$		0.4	V
Output High Level	$V_{OH(IO)}$	$I_{SOURCE} = 20\mu A$	$0.8 \cdot V_{CC}$		V

SIM/Smart Card Level Translators in μ MAX

MAX1740/MAX1741

ELECTRICAL CHARACTERISTICS (continued)

(Figure 1, $DV_{CC} = +1.8V$, $V_{CC} = +3.0V$ or $+5.0V$, $\overline{SHDN} = DV_{CC}$, $C_{IN} = R_{IN} = GND$ or DV_{CC} , $I_O = V_{CC}$, $DATA = DDRV = DV_{CC}$, $C_{IO} = C_{CLK} = C_{RST} = C_{DATA} = 30pF$, $T_A = -40^{\circ}C$ to $+85^{\circ}C$, unless otherwise noted.) (Note 5)

PARAMETER	SYMBOL	CONDITIONS	MIN	MAX	UNITS
SHUTDOWN OUTPUT LEVELS					
Shutdown Output Levels (IO, CLK, RST)		$I_{SINK} = 200\mu A$, $\overline{SHDN} = GND$, $DATA = CIN = RIN = DV_{CC}$ (MAX1740 only)		0.4	V
		$I_{SINK} = 200\mu A$, $DV_{CC} = GND$, \overline{SHDN} (MAX1740) = $DDRV$ (MAX1741) = $DATA = CIN = RIN = DV_{CC}$		0.4	V
		$I_{SINK} = 200\mu A$, $V_{CC} = GND$, \overline{SHDN} (MAX1740) = $DDRV$ (MAX1741) = $DATA = CIN = RIN = DV_{CC}$		0.4	V
TIMING					
Maximum CLK Frequency (Notes 3, 4)	f_{CLK}	$V_{CC} = 2.7V$ to $5.5V$	$DV_{CC} = 2.7V$	5	MHz
			$DV_{CC} = 2.25V$	5	
			$DV_{CC} = 1.7V$	5	
			$DV_{CC} = 1.425V$	3.5	
		$V_{CC} = 2.25V$ to $3.6V$	$DV_{CC} = 2.25V$	4	
			$DV_{CC} = 1.7V$	4	
		$DV_{CC} = 1.425V$	3.5		

Note 1: V_{IL} is defined as the voltage at which the output (DATA/IO) voltage equals 0.5V.

Note 2: V_{IH} is defined as the voltage at which the output (DATA/IO) voltage exceeds the input (IO/DATA) voltage by 100mV.

Note 3: Timing specifications are guaranteed by design, not production tested.

Note 4: The maximum CLK frequency is defined as the output duty cycle remaining in the 40% to 60% range when the 50% CIN is applied. CIN has 5ns rise and fall times; levels are GND to DV_{CC} . Input and output levels are measured at 50% of the waveform.

Note 5: Specifications to $-40^{\circ}C$ are guaranteed by design, not production tested.

Typical Operating Characteristics

(Circuit of Figure 1, $DV_{CC} = 3.0V$, $V_{CC} = 5.0V$, $DDRIV$ or $DATA = DV_{CC}$, $R_{IN} = C_{IN} = GND$, $T_A = +25^{\circ}C$, unless otherwise noted.)

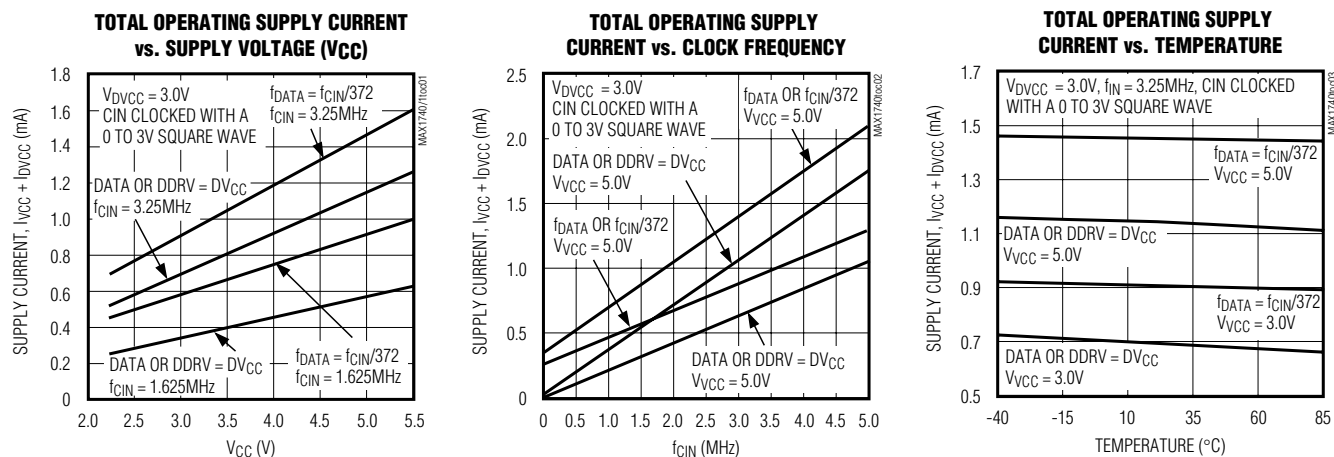

SIM/Smart Card Level Translators in μ MAX

Typical Operating Characteristics (continued)

(Circuit of Figure 1, DV_{CC} = 3.0V, V_{CC} = 5.0V, DDRV or DATA = DV_{CC}, RIN = CIN = GND, T_A = +25°C, unless otherwise noted.)

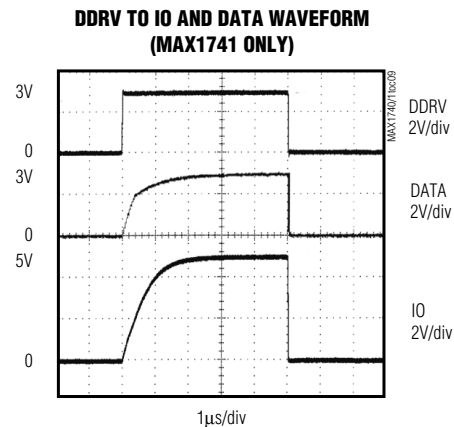
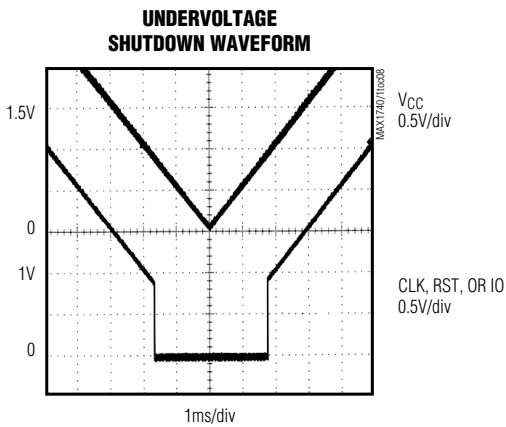
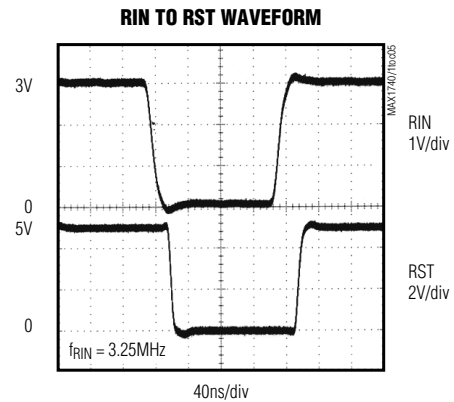
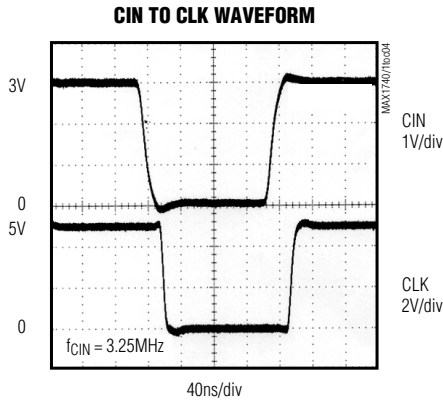

SIM/Smart Card Level Translators in μ MAX

Pin Description

MAX1740/MAX1741

PIN		NAME	FUNCTION
MAX1740	MAX1741		
1	1	DATA	System Controller Data Input/Output. An open-drain input/output with a 20k Ω pull-up resistor to DV _{CC} . For bidirectional data transfer, connect to an open-drain controller output capable of sinking 1mA while pulling DATA low. If the controller is not open drain, use DDRV to send data and DATA to receive data.
2	2	DV _{CC}	Supply Voltage for System Controller Digital Pins. Set at +1.425V to +5.5V.
3	3	CIN	System Controller Clock Input
4	4	RIN	System Controller Reset Input
—	5	DDRV	Optional System Controller Data Input. Connect to controllers without an open-drain output. When not used, connect DDRV to DV _{CC} .
5	—	$\overline{\text{SHDN}}$	Shutdown Mode Input. Driving $\overline{\text{SHDN}}$ low reduces the total supply current to less than 2 μ A. In shutdown mode, RST, CLK, and IO are actively pulled low and the transfer gate between DATA and IO is disabled. When not used, connect $\overline{\text{SHDN}}$ to DV _{CC} .
6	6	GND	System Controller and Card Ground
7	7	RST	Reset Output to Card. Actively pulled low during shutdown.
8	8	CLK	Clock Output to Card. Actively pulled low during shutdown.
9	9	V _{CC}	Supply Voltage for Card-Side Digital Pins. Set at +2.25V to +5.5V. Proper supply bypassing is required to meet \pm 10kV ESD specifications.
10	10	IO	Card-Side Bidirectional Input/Output. An open-drain output with a 10k Ω pull-up resistor to V _{CC} . For bidirectional data transfer, connect to an open-drain card output capable of sinking 1mA while pulling IO low. Actively pulled low during shutdown.

Detailed Description

The MAX1740/MAX1741 provide the necessary level translation for interfacing with subscriber identity modules (SIMs) and smart cards in multivoltage systems. These devices operate with logic supply voltages between +1.425V and +5.5V on the controller side (DV_{CC}) and between +2.25V and +5.5V on the card side (V_{CC}). The total supply current (I_{DVCC} + I_{VCC}) is 2.5 μ A (max) while operating in an idle state (see *Electrical Characteristics*). Figure 2 shows a typical application circuit and functional diagram.

Level Translation

The MAX1740/MAX1741 provide level translators for a clock input, a reset input, and a bidirectional data input/output. The clock and reset inputs (CIN and RIN) are level shifted from the controller-side supply rails (DV_{CC} to GND) to the card-side supply rails (V_{CC} to GND). When connected to an open-drain controller output, DATA and IO provide bidirectional level translation.

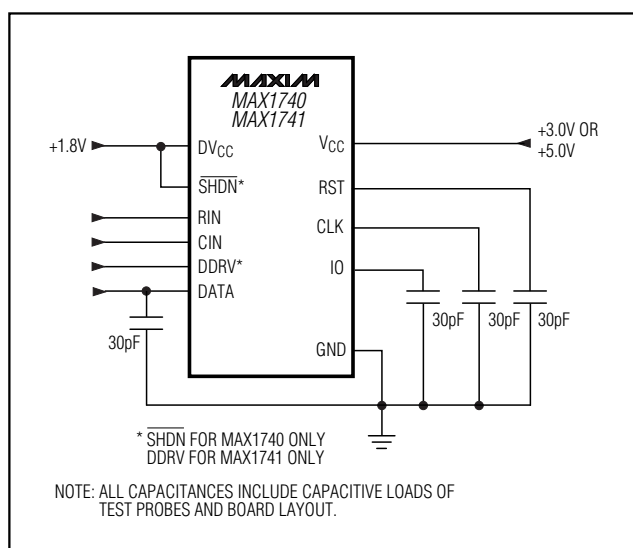

Figure 1. MAX1740/MAX1741 Test Circuit

SIM/Smart Card Level Translators in μ MAX

All level translation is valid for $DV_{CC} \geq V_{CC}$ or $DV_{CC} \leq V_{CC}$. The MAX1740/MAX1741 contain internal pull-up resistors from DATA to the controller-side supply (DV_{CC}) and from IO to the card-side supply (V_{CC}). For push-pull controller outputs, see the *Data Driver* section for bidirectional data translation.

Data Driver (MAX1741 only)

When using a microcontroller (μ C) without an open-drain output, use the data driver (DDRV) input to send data to the SIM/smart card, while DATA provides the controller-side output for bidirectional data transfer. When not used, connect DDRV to DV_{CC} to reduce total supply current.

Shutdown Mode

For the MAX1740, drive \overline{SHDN} low to activate shutdown. Connect \overline{SHDN} to DV_{CC} or drive high for normal operation. To allow for card insertion and removal, shutdown mode actively pulls CLK, RST, and IO low; it also disconnects the internal $10k\Omega$ pull-up resistor from V_{CC} to prevent excessive current draw. Shutdown mode reduces the total supply current ($I_{DV_{CC}} + I_{V_{CC}}$) to $0.01\mu A$.

SIM/Smart Card Insertion/Removal

The SIM/smart card specifications require that the card-side pins (V_{CC} , CLK, RST, IO) be at ground potential prior to inserting the SIM/smart card. For applications using the MAX1686H (Figure 4), the easi-

est way to achieve this is by shutting down the MAX1686H or by driving \overline{SHDN} (MAX1740 only) low. If specific sequencing is desired, pull IO low by driving either DATA or DDRV (MAX1741 only) low, and pull CLK and RST low by driving CIN and RIN low, respectively.

ESD Protection

As with all Maxim devices, ESD-protection structures on all pins protect against electrostatic discharges (ESDs) encountered during handling and assembly. For further protection during card insertion and removal, the pins that connect to the card socket (CLK, RST, IO, V_{CC} , and GND) provide protection against $\pm 10kV$ of ESD, according to the Human Body Model. The ESD structures withstand high ESD in all states: normal operation, shutdown, and power-down. After an ESD event, the MAX1740/MAX1741 continue working without latching.

ESD Test Conditions

ESD performance depends on a variety of conditions. Contact Maxim for a reliability report documenting test setup, test methodology, and test results.

Human Body Model

Figure 3a shows the Human Body Model, and Figure 3b shows the current waveform it generates when discharged into a low impedance. This model consists of a $100pF$ capacitor charged to the ESD voltage of inter-

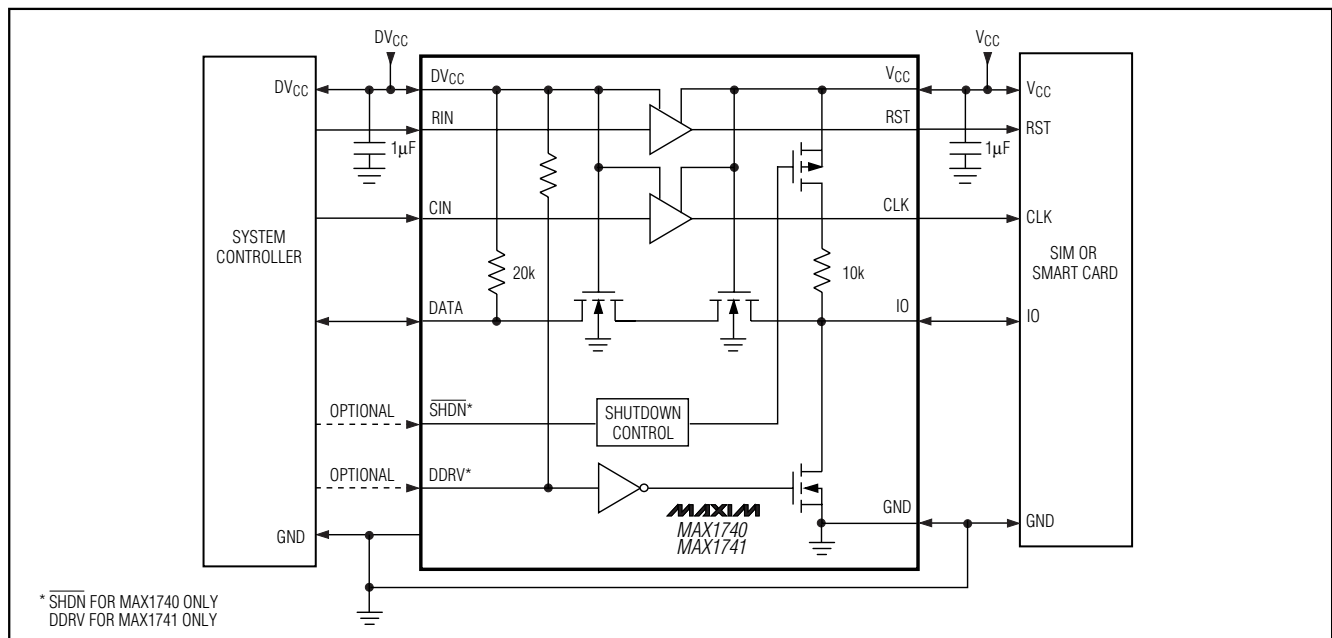

Figure 2. Typical Application Circuit and Functional Diagram

SIM/Smart Card Level Translators in μ MAX

MAX1740/MAX1741

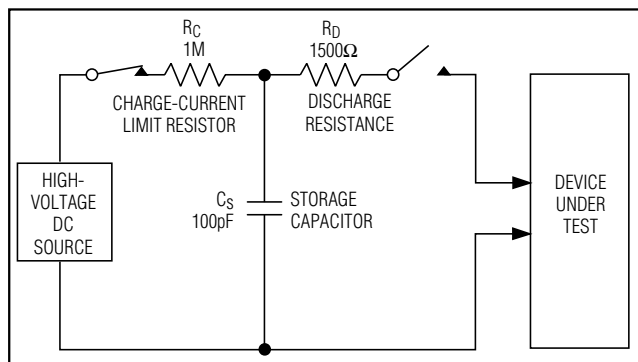

Figure 3a. Human Body ESD Test Model

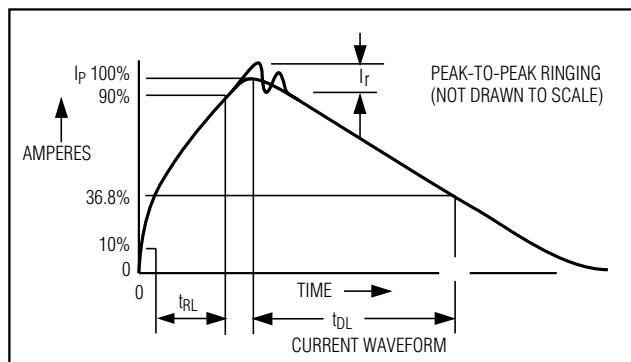

Figure 3b. Human Body Model Current Waveform

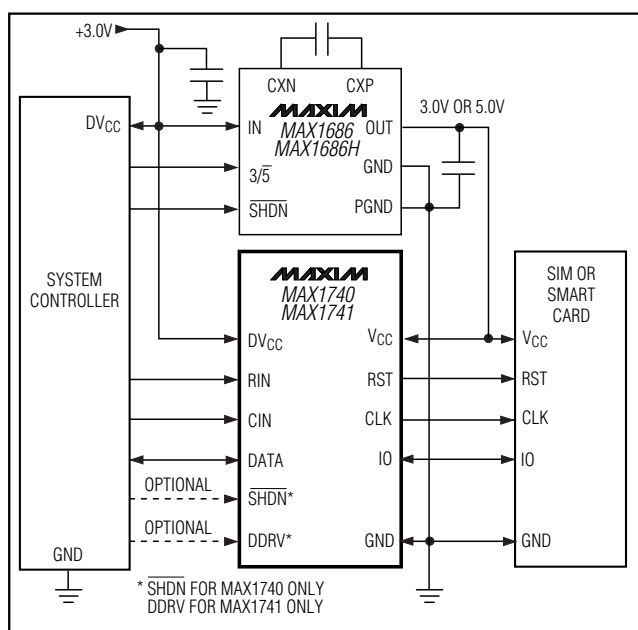

Figure 4. Using MAX1740/MAX1741 and MAX1686/MAX1686H Charge Pump for SIM Card Applications

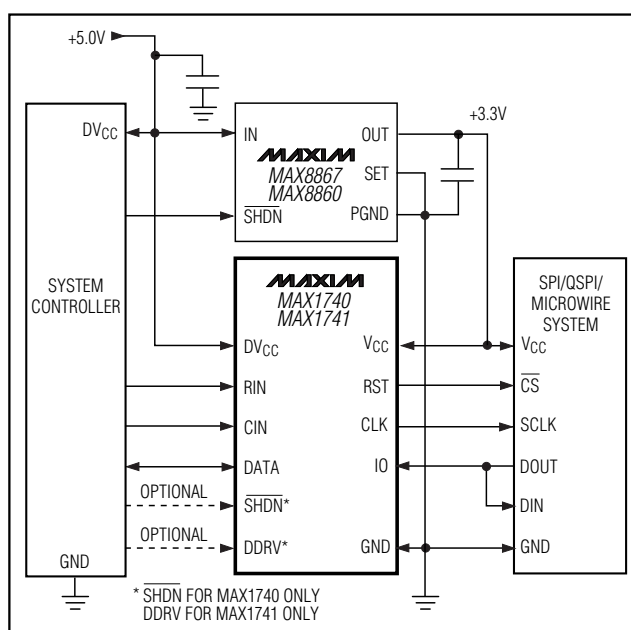

Figure 5. MAX1740/MAX1741 with SPI/QSPI/MICROWIRE Interfaces

est, which is then discharged into the test device through a 1.5k Ω resistor.

Applications Information

SIM/Smart Card Interface

To provide 5V when interfacing with a 5V SIM/smart card, 3V systems require a DC-DC converter. The MAX1686H +5V regulating charge pump for SIM cards provides 0V/3V/5V for full compatibility with SIM/smart card specifications. Figure 4 shows the charge pump for SIM card applications. Alternatively, the MAX619 generates a regulated 5V from input voltages as low as 2V.

SPI/QSPI/MICROWIRE Interface

The MAX1740/MAX1741 are also useful as 3V/5V level shifters in SPI, QSPI, and MICROWIRE applications (Figure 5). On the slave side, connect CLK to SCLK, RST to \overline{CS} , and IO to DOUT and DIN. The unidirectional level shifters transfer chip select and clock signals to the slave device(s), while the bidirectional level shifter transfers data.

Chip Information

TRANSISTOR COUNT: 114

SIM/Smart Card Level Translators in μ MAX

Package Information

TOLLUMAX.EPS

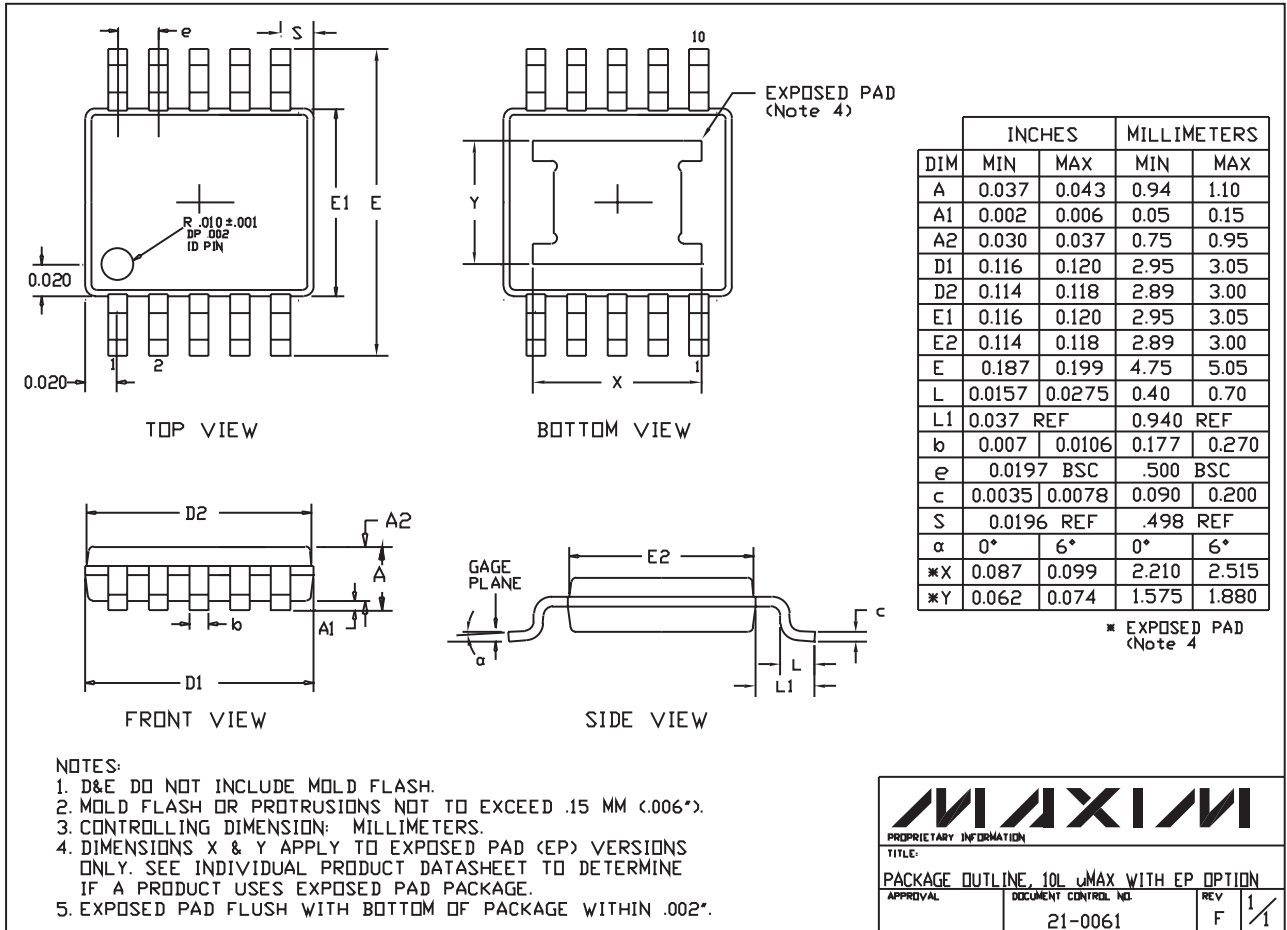

Note: The MAX1740/MAX1741 do not have an exposed pad.

SIM/Smart Card Level Translators in μ MAX

NOTES

MAX1740/MAX1741

SIM/Smart Card Level Translators in μ MAX

NOTES

Maxim cannot assume responsibility for use of any circuitry other than circuitry entirely embodied in a Maxim product. No circuit patent licenses are implied. Maxim reserves the right to change the circuitry and specifications without notice at any time.

12 _____ **Maxim Integrated Products, 120 San Gabriel Drive, Sunnyvale, CA 94086 408-737-7600**

Looking for pricing, stock, or lifecycle information?

Click below to explore more details on WIN SOURCE:

 [View MAX1741EUB+T on WIN SOURCE](#)

 [Maxim Integrated Information](#)

Optimize Your Supply Chain with WIN SOURCE Solutions

-  Global Sourcing Solution
-  Obsolete Management
-  Cost Control Management
-  Shortage Management
-  Alternative Solution
-  Excess Inventory Management