



**THE DATASHEET OF
NB7L86AMNG**



2.5 V/3.3 V SiGe Differential Smart Gate with Output Level Select

NB7L86A

The NB7L86A is a multi-function differential Logic Gate which can be configured as an AND/NAND, OR/NOR, XOR/XNOR, or 2:1 MUX. This device is part of the GigaComm™ family of high performance Silicon Germanium products. The device is housed in a 3 x 3 mm 16 pin QFN package.

Differential inputs incorporate internal 50 Ω termination resistors and accept NECL (Negative ECL), PECL (Positive ECL), LVCMOS/LVTTL, CML, or LVDS. The Output Level Select (OLS) input is used to program the peak-to-peak output amplitude between 0 and 800 mV in five discrete steps.

The NB7L86A employs input default circuitry so that under open input condition (\overline{Dx} , \overline{Dx} , \overline{VTDx} , \overline{VTDx} , \overline{VTSEL}) the Outputs of the device remains stable.

Features

- Maximum Input Clock Frequency > 8 GHz Typical
- Maximum Input Data Rate > 8 Gb/s Typical
- 165 ps Typical Propagation Delay
- 40 ps Typical Rise and Fall Times
- Selectable Swing PECL Output with Operating Range:
 $V_{CC} = 2.375\text{ V to }3.465\text{ V}$ with $V_{EE} = 0\text{ V}$
- Selectable Swing NECL Output with NECL Inputs with Operating Range:
 $V_{CC} = 0\text{ V}$ with $V_{EE} = -2.375\text{ V to }-3.465\text{ V}$
- Selectable Output Level
 (0 V, 200 mV, 400 mV, 600 mV, or 800 mV Peak-to-Peak Output)
- 50 Ω Internal Input Termination Resistors
- This is a Pb-Free Device



QFN16 3x3, 0.5P
 CASE 485G

MARKING DIAGRAM

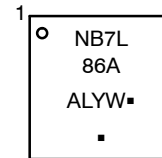

- A = Assembly Location
- L = Wafer Lot
- Y = Year
- W = Work Week
- = Pb-Free Package

(Note: Microdot may be in either location)

ORDERING INFORMATION

See detailed ordering and shipping information on page 17 of this data sheet.

NB7L86A

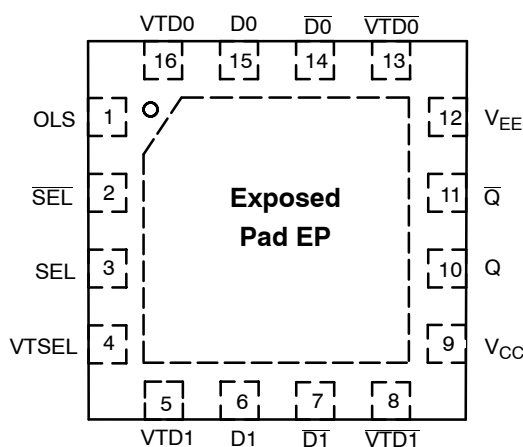

Figure 1. QFN16 Pinout (Top View)

Table 1. PIN DESCRIPTION

Pin	Name	I/O	Description
1	OLS (Note 3)	Input	Input for OLS (Output Level Select) Pin. Refer Table 2
2	SEL	Input: LVCMOS/LVTTL, ECL/CML/LVDS	Input for Select Logic Pin, Single Ended or Inverted Differential
3	SEL	Input: LVCMOS/LVTTL, ECL/CML/LVDS	Input for Select Logic Pin, Single Ended or non-Inverted Differential
4	VTSEL (Note 1)		Pin with a common internal 50 Ω termination from SEL/SEL Pins. Refer Table 7 for usage with different Interface options
5	VTD1 (Note 1)		Pin with an internal 50 Ω termination from D1 Pin. Refer Table 7 for usage with different Interface options
6	D1	Input: LVCMOS/LVTTL, ECL/CML/LVDS	Input Pin, Non-inverted Differential or Single Ended with internal 75 k Ω connected to V _{EE}
7	D1	Input: LVCMOS/LVTTL, ECL/CML/LVDS	Input Pin, Inverted Differential or Single Ended with internal 75 k Ω connected to V _{EE} and 36.5 k Ω connected to V _{CC}
8	VTD1 (Note 1)		Pin with an internal 50 Ω termination from D1 Pin. Refer Table 7 for usage with different Interface options
9	V _{CC} (Note 2)		Positive Supply Voltage
10	Q	Output: Reduced Swing ECL	Output Pin, non-inverted Differential Output with typical 50 Ω termination to V _{TT} = V _{CC} - 2 V
11	Q	Output: Reduced Swing ECL	Output Pin, inverted Differential Output with typical 50 Ω termination to V _{TT} = V _{CC} - 2 V
12	V _{EE} (Note 2)		Negative Supply Voltage
13	VTD0 (Note 1)		Pin with an internal 50 Ω termination from D0 Pin. Refer Table 7 for usage with different Interface options
14	D0	Input: LVCMOS/LVTTL, ECL/CML/LVDS	Input Pin, Inverted Differential or Single Ended with internal 75 k Ω connected to V _{EE} and 36.5 k Ω connected to V _{CC}
15	D0	Input: LVCMOS/LVTTL, ECL/CML/LVDS	Input Pin, Non-inverted Differential or Single Ended with internal 75 k Ω connected to V _{EE}
16	VTD0 (Note 1)		Pin with an internal 50 Ω termination from D0 Pin. Refer Table 7 for usage with different Interface options
	EP		Exposed Pad (EP) is thermally connected to the die for improved heat transfer out of the package. The exposed pad can be connected electrically to V _{EE} on the PCB board

1. In the differential configuration when the input termination pins (VTD0/1, VTD0/1, VTSEL) are connected to a common termination voltage, or left open, and if no signal is applied then the device will be susceptible to self-oscillation.
2. All V_{CC} and V_{EE} pins must be externally connected to Power Supply to guarantee proper operation.
3. When an output level of 400 mV is desired and V_{CC} - V_{EE} > 3.0 V, 2 k Ω resistor should be connected from OLS pin to V_{EE}.

Table 2. OUTPUT LEVEL SELECT OLS

OLS	Q/Q̄ VPP	OLS Sensitivity
V _{CC}	800 mV	OLS - 75 mV
V _{CC} - 0.4 V	200 mV	OLS ± 150 mV
V _{CC} - 0.8 V	600 mV	OLS ± 100 mV
V _{CC} - 1.2 V	0 mV	OLS ± 75 mV
V _{EE} (Note 4)	400 mV	OLS ± 100 mV
Float	600 mV	N/A

4. When an output level of 400 mV is desired and V_{CC} - V_{EE} > 3.0 V, 2 kΩ resistor should be connected from OLS to V_{EE}.

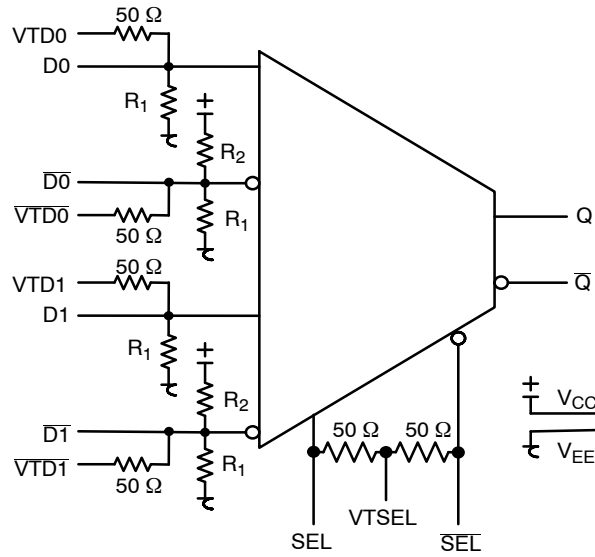

Figure 2. Logic Diagram

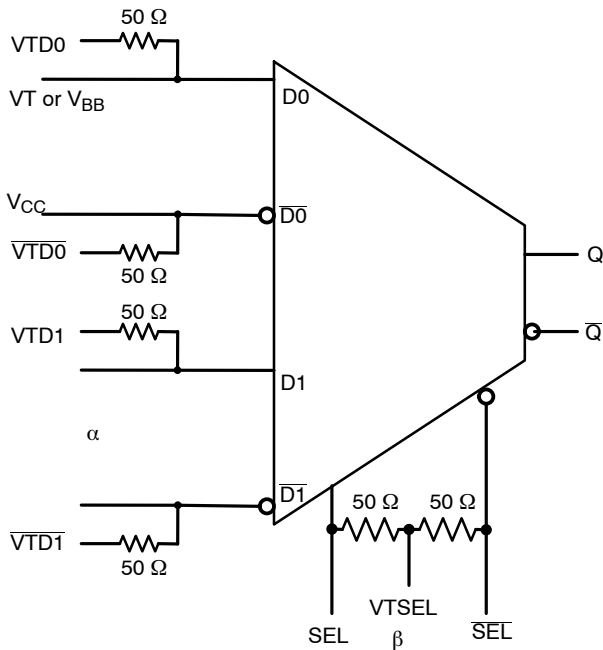

Figure 3. Configuration for AND/NAND Function

Table 3. AND/NAND TRUTH TABLE (Note 5)

	α	β	$\alpha * \beta$
D0	D1	SEL	Q
0	0	0	0
0	0	1	0
0	1	0	0
0	1	1	1

5. D0, D1, SEL are inverse of $\bar{D}0$, $\bar{D}1$, \bar{SEL} unless specified otherwise.

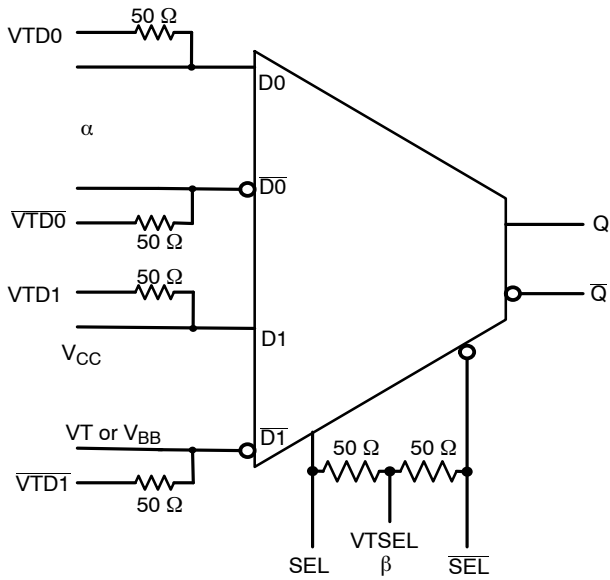

Figure 4. Configuration for OR/NOR Function

Table 4. OR/NOR TRUTH TABLE (*)

α		β	α or β
D0	D1	SEL	Q
0	1	0	0
0	1	1	1
1	1	0	1
1	1	1	1

*D0, D1, SEL are inverse of $\overline{D0}$, $\overline{D1}$, \overline{SEL} unless specified otherwise.

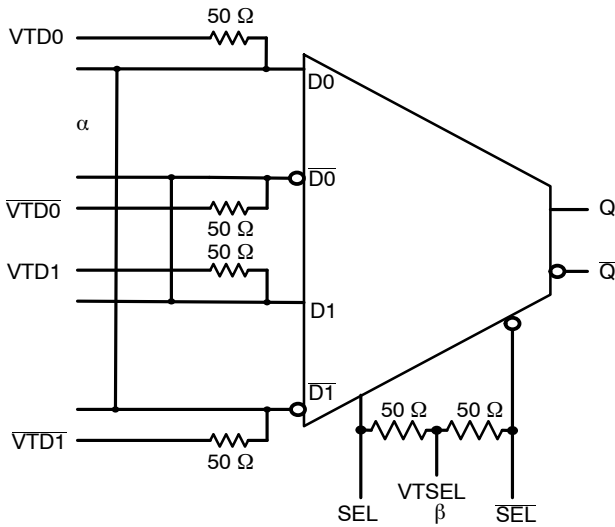

Figure 5. Configuration for XOR/XNOR Function

Table 5. XOR/XNOR TRUTH TABLE (*)

α		β	α XOR β
D0	D1	SEL	Q
0	1	0	0
0	1	1	1
1	0	0	1
1	0	1	0

*D0, D1, SEL are inverse of $\overline{D0}$, $\overline{D1}$, \overline{SEL} unless specified otherwise.

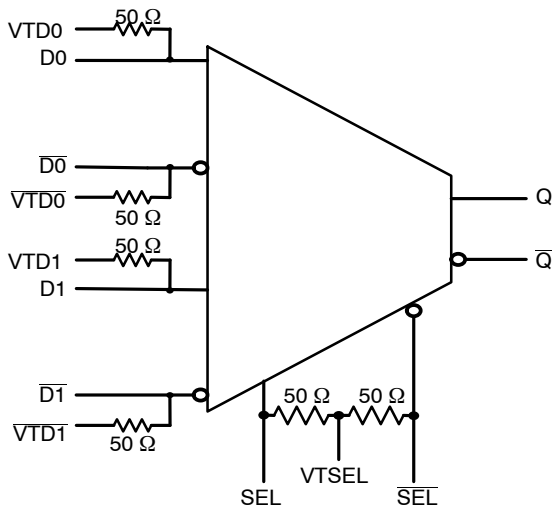

Figure 6. Configuration for 2:1 MUX Function

Table 6. 2:1 MUX TRUTH TABLE (*)

SEL	Q
1	D1
0	D0

*D0, D1, SEL are inverse of $\overline{D0}$, $\overline{D1}$, \overline{SEL} unless specified otherwise.

NB7L86A

Table 7. INTERFACING OPTIONS

INTERFACING OPTIONS	CONNECTIONS
CML	Connect $\overline{VTD0}$, VTD0, VTSEL, $\overline{VTD1}$, VTD1 TO V_{CC}
LVDS	Connect $\overline{VTD0}$, VTD0, $\overline{VTD1}$, and VTD1 together. Leave VTSEL open
AC-COUPLED	Bias $\overline{VTD0}$, VTD0, VTSEL, $\overline{VTD1}$, VTD1 and VTSEL inputs within the Common Mode range (VIHCMR)
RSECL, PECL, NECL	Standard ECL termination techniques
LVTTTL, LVCMOS	An external voltage should be applied to the unused complementary differential input. Nominal voltage of 1.5 V for LVTTTL and $V_{CC}/2$ for LVCMOS inputs

Table 8. ATTRIBUTES

Characteristics	Value
Internal Input Pulldown Resistors (R_1)	75 k Ω
Internal Input Pullup Resistor (R_2)	37.5 k Ω
ESD Protection:	
Human Body Model	≥ 4 kV
Charged Device Model	≥ 2 kV
Machine Model	≥ 200 V
Moisture Sensitivity (Note 6), Pb-Free	Level 1
Flammability Rating, Oxygen Index: 28 to 34	UL 94 V-0 @ 0.125 in
Meets or exceeds JEDEC Spec EIA/JESD78 IC Latchup Test	

6. For additional information, see Application Note AND8003/D.

Table 9. MAXIMUM RATINGS

Symbol	Parameter	Condition 1	Condition 2	Rating	Unit
V_{CC}	Positive Power Supply	$V_{EE} = 0$ V		3.6	V
V_{EE}	Negative Power Supply	$V_{CC} = 0$ V		-3.6	V
V_I	Positive Input	$V_{EE} = 0$ V	$V_I \leq V_{CC}$	3.6	V
	Negative Input	$V_{CC} = 0$ V	$V_I \geq V_{EE}$	-3.6	V
V_{INPP}	Differential Input Voltage $ Dn - \overline{Dn} , SEL - \overline{SEL} $	$V_{CC} - V_{EE} \geq 2.8$ V		2.8	V
		$V_{CC} - V_{EE} \leq 2.8$ V		$ V_{CC} - V_{EE} $	
I_{IN}	Input Current through RT (50 Ω Resistor)	Static		45	mA
		Surge		80	mA
I_{OUT}	Output Current	Continuous		25	mA
		Surge		50	mA
T_A	Operating Temperature Range			-40 to +85	$^{\circ}$ C
T_{stg}	Storage Temperature Range			-65 to +150	$^{\circ}$ C
θ_{JA}	Thermal Resistance (Junction-to-Ambient) (Note 7)	0 lfpm		41.6	$^{\circ}$ C/W
		500 lfpm		35.2	$^{\circ}$ C/W
θ_{JC}	Thermal Resistance (Junction-to-Case)	2S2P (Note 7)		4	$^{\circ}$ C/W
T_{sol}	Wave Solder (Pb-Free)	< 3 sec @ 260 $^{\circ}$ C		265	$^{\circ}$ C

Stresses exceeding those listed in the Maximum Ratings table may damage the device. If any of these limits are exceeded, device functionality should not be assumed, damage may occur and reliability may be affected.

7. JEDEC standard multilayer board - 2S2P (2 signal, 2 power) with 8 filled thermal vias under exposed pad.

NB7L86A

Table 10. DC CHARACTERISTICS, INPUT WITH LVPECL OUTPUT: $V_{CC} = 2.5\text{ V}$; $V_{EE} = 0\text{ V}$, $T_A = -40^\circ\text{C}$ to $+85^\circ\text{C}$ (Note 8)

Symbol	Characteristic	-40°C			25°C			85°C			Unit
		Min	Typ	Max	Min	Typ	Max	Min	Typ	Max	
POWER SUPPLY CURRENT											
I_{EE}	Negative Power Supply Current	23	30	39	23	30	39	23	30	39	mA
LVPECL OUTPUTS (Note 9)											
V_{OH}	Output HIGH Voltage	1460	1510	1570	1490	1540	1600	1515	1565	1625	mV
V_{OL}	Output LOW Voltage										mV
	(OLS = V_{CC})	555	705	855	595	745	895	625	775	925	
	(OLS = $V_{CC} - 0.4\text{ V}$)	1235	1295	1385	1270	1330	1420	1295	1355	1445	
	(OLS = $V_{CC} - 0.8\text{ V}$, OLS = FLOAT)	775	895	1015	810	930	1050	840	960	1080	
	(OLS = $V_{CC} - 1.2\text{ V}$)	1455	1505	1585	1490	1540	1620	1510	1560	1640	
	(OLS = V_{EE})	1005	1095	1215	1040	1130	1250	1065	1155	1275	
V_{OUTPP}	Output Voltage Amplitude										mV
	(OLS = V_{CC})	670	800		660	795		655	790		
	(OLS = $V_{CC} - 0.4\text{ V}$)	125	215		120	210		120	210		
	(OLS = $V_{CC} - 0.8\text{ V}$, OLS = FLOAT)	510	615		505	610		500	605		
	(OLS = $V_{CC} - 1.2\text{ V}$)	0	5		0	0		0	5		
	(OLS = V_{EE})	325	415		320	410		320	410		
DIFFERENTIAL CLOCK INPUTS DRIVEN SINGLE ENDED (Figure 11 & 13) (Note 10)											
V_{IH}	Input HIGH Voltage (Single-Ended): D, \bar{D} , SEL, \bar{SEL}	1200		V_{CC}	1200		V_{CC}	1200		V_{CC}	mV
V_{IL}	Input LOW Voltage (Single-Ended): D, \bar{D} , SEL, \bar{SEL}	0		$V_{CC} - 150$	0		$V_{CC} - 150$	0		$V_{CC} - 150$	mV
V_{th}	Input Threshold Reference Voltage Range (Note 11)	950		$V_{CC} - 75$	950		$V_{CC} - 75$	950		$V_{CC} - 75$	mV
V_{ISE}	Single-Ended Input Voltage ($V_{IH} - V_{IL}$)	150		2600	150		2600	150		2600	mV
DIFFERENTIAL INPUTS DRIVEN DIFFERENTIALLY (Figure 12) (Note 12)											
V_{IHD}	Differential Input HIGH Voltage (D, \bar{D} , SEL, \bar{SEL})	1200		V_{CC}	1200		V_{CC}	1200		V_{CC}	mV
V_{ILD}	Differential Input LOW Voltage (D, \bar{D} , SEL, \bar{SEL})	0		$V_{CC} - 75$	0		$V_{CC} - 75$	0		$V_{CC} - 75$	mV
V_{ID}	Differential Input Voltage ($V_{IHD} - V_{ILD}$) (D, \bar{D} , SEL, \bar{SEL})	75		2600	75		2600	75		2600	mV
V_{IHCMR}	Input HIGH Voltage Common Mode Range (Differential Configuration) (Note 13) (Figure 15)	1200		2500	1200		2500	1200		2500	mV
I_{IH}	Input HIGH Current (@ V_{IH}) D, \bar{D} , SEL, \bar{SEL}		30	100		30	100		30	100	μA
			5	50		5	50		5	50	
I_{IL}	Input LOW Current (@ V_{IL}) D, \bar{D} , SEL, \bar{SEL}		20	100		20	100		20	100	μA
			5	50		5	50		5	50	
TERMINATION RESISTORS											
R_{TIN}	Internal Input Termination Resistor	45	50	55	45	50	55	45	50	55	Ω

Product parametric performance is indicated in the Electrical Characteristics for the listed test conditions, unless otherwise noted. Product performance may not be indicated by the Electrical Characteristics if operated under different conditions.

NOTE: Device will meet the specifications after thermal equilibrium has been established when mounted in a test socket or printed circuit board with maintained transverse airflow greater than 500 lfm.

8. Input and output parameters vary 1:1 with V_{CC} .

9. LVPECL outputs loaded with 50 Ω to ($V_{CC} - 2\text{ V}$) for proper operation.

10. V_{th} , V_{IH} , V_{IL} , and V_{ISE} parameters must be complied with simultaneously.

11. V_{th} is applied to the complementary input when operating in single-ended mode. $V_{th} = (V_{IH} - V_{IL}) / 2$.

12. V_{IHD} , V_{ILD} , V_{ID} and V_{CMR} parameters must be complied with simultaneously.

13. V_{IHCMR} min varies 1:1 with V_{EE} , V_{IHCMR} max varies 1:1 with V_{CC} . The V_{IHCMR} range is referenced to the most positive side of the differential input signal.

NB7L86A

Table 11. DC CHARACTERISTICS, INPUT WITH LVPECL OUTPUT $V_{CC} = 3.3\text{ V}$; $V_{EE} = 0\text{ V}$, $T_A = -40^\circ\text{C}$ to $+85^\circ\text{C}$ (Note 14)

Symbol	Characteristics	-40°C			25°C			85°C			Unit	
		Min	Typ	Max	Min	Typ	Max	Min	Typ	Max		
POWER SUPPLY CURRENT												
I_{EE}	Negative Power Supply Current	23	30	39	23	30	39	23	30	39	mA	
LVPECL OUTPUTS (Note 15)												
V_{OH}	Output HIGH Voltage	2260	2310	2370	2290	2340	2400	2315	2365	2425	mV	
V_{OL}	Output LOW Voltage:											mV
	(OLS = V_{CC})	1320	1470	1620	1360	1510	1660	1390	1540	1690		
	(OLS = $V_{CC} - 0.4\text{ V}$)	2030	2090	2180	2065	2125	2215	2090	2150	2240		
	(OLS = $V_{CC} - 0.8\text{ V}$, OLS = FLOAT)	1550	1670	1790	1585	1705	1825	1615	1735	1855		
	(OLS = $V_{CC} - 1.2\text{ V}$)	2260	2310	2390	2290	2340	2420	2315	2365	2445		
	(OLS = V_{EE}) (Note 20)	1785	1875	1995	1820	1910	2030	1850	1940	2060		
V_{OUTPP}	Output Amplitude Voltage:											mV
	(OLS = V_{CC})	705	815		695	805		690	800			
	(OLS = $V_{CC} - 0.4\text{ V}$)	130	220		125	215		125	215			
	(OLS = $V_{CC} - 0.8\text{ V}$, OLS = FLOAT)	535	640		530	635		525	630			
	(OLS = $V_{CC} - 1.2\text{ V}$)	0	0		0	0		0	0			
	(OLS = V_{EE}) (Note 20)	345	435		340	430		335	425			
DIFFERENTIAL CLOCK INPUTS DRIVEN SINGLE-ENDED (Figure 11 & 13) (Note 16)												
V_{IH}	Input HIGH Voltage (Single-Ended) D, \bar{D} , SEL, \bar{SEL}	1200		V_{CC}	1200		V_{CC}	1200		V_{CC}	mV	
V_{IL}	Input LOW Voltage (Single-Ended) D, \bar{D} , SEL, \bar{SEL}	0		$V_{CC} - 150$	0		$V_{CC} - 150$	0		$V_{CC} - 150$	mV	
V_{th}	Input Threshold Reference Voltage Range (Note 17)	950		$V_{CC} - 75$	950		$V_{CC} - 75$	950		$V_{CC} - 75$	mV	
V_{ISE}	Single-Ended Input Voltage ($V_{IH} - V_{IL}$)	150		2600	150		2600	150		2600	mV	
DIFFERENTIAL INPUTS DRIVEN DIFFERENTIALLY (Figure 12) (Note 18)												
V_{IHD}	Differential Input HIGH Voltage (D, \bar{D} , SEL, \bar{SEL})	1200		V_{CC}	1200		V_{CC}	1200		V_{CC}	mV	
V_{ILD}	Differential Input LOW Voltage (D, \bar{D} , SEL, \bar{SEL})	0		$V_{CC} - 75$	0		$V_{CC} - 75$	0		$V_{CC} - 75$	mV	
V_{ID}	Differential Input Voltage ($V_{IHD} - V_{ILD}$) (D, \bar{D} , SEL, \bar{SEL})	75		2600	75		2600	75		2600	mV	
V_{IHCMR}	Input HIGH Voltage Common Mode Range (Differential Configuration) (Note 19) (Figure 15)	1200		3300	1200		3300	1200		3300	mV	
I_{IH}	Input HIGH Current (@ V_{IH}) D, \bar{D} SEL, \bar{SEL}		30	100		30	100		30	100	μA	
			5	50		5	50		5	50		
I_{IL}	Input LOW Current (@ V_{IL}) D, \bar{D} SEL, \bar{SEL}		20	100		20	100		20	100	μA	
			5	50		5	50		5	50		
TERMINATION RESISTORS												
R_{TIN}	Internal Input Termination Resistor	45	50	55	45	50	55	45	50	55	Ω	

Product parametric performance is indicated in the Electrical Characteristics for the listed test conditions, unless otherwise noted. Product performance may not be indicated by the Electrical Characteristics if operated under different conditions.

NOTE: Device will meet the specifications after thermal equilibrium has been established when mounted in a test socket or printed circuit board with maintained transverse airflow greater than 500 lfm.

14. Input and output parameters vary 1:1 with V_{CC} .

15. LVPECL outputs loaded with 50 Ω to ($V_{CC} - 2\text{ V}$) for proper operation.

16. V_{th} , V_{IH} , V_{IL} , and V_{ISE} parameters must be complied with simultaneously.

17. V_{th} is applied to the complementary input when operating in single-ended mode. $V_{th} = (V_{IH} - V_{IL}) / 2$.

18. V_{IHD} , V_{ILD} , V_{ID} and V_{CMR} parameters must be complied with simultaneously.

19. V_{IHCMR} min varies 1:1 with V_{EE} . V_{IHCMR} max varies 1:1 with V_{CC} . The V_{IHCMR} range is referenced to the most positive side of the differential input signal.

20. When an output level of 400 mV is desired and $V_{CC} - V_{EE} > 3.0\text{ V}$, a 2 k Ω resistor should be connected from OLS to V_{EE} .

NB7L86A

Table 12. DC CHARACTERISTICS, NECL INPUT WITH NECL OUTPUT

$V_{CC} = 0\text{ V}$; $V_{EE} = -3.465\text{ V}$ to -2.375 V , $T_A = -40^\circ\text{C}$ to $+85^\circ\text{C}$ (Note 21)

Symbol	Characteristics	-40°C			25°C			85°C			Unit
		Min	Typ	Max	Min	Typ	Max	Min	Typ	Max	

POWER SUPPLY CURRENT

I_{EE}	Negative Power Supply Current	23	30	39	23	30	39	23	30	39	mA
----------	-------------------------------	----	----	----	----	----	----	----	----	----	----

LVPECL OUTPUTS (Note 22)

V_{OH}	Output HIGH Voltage	-1040	-990	-930	-1010	-960	-900	-985	-935	-875	mV
V_{OL}	Output LOW Voltage:										mV
	$-3.465\text{ V} \leq V_{EE} \leq -3.0\text{ V}$										
	(OLS = V_{CC})	-1980	-1830	-1680	-1940	-1790	-1640	-1910	-1760	-1610	
	(OLS = $V_{CC} - 0.4\text{ V}$)	-1270	-1210	-1120	-1235	-1175	-1085	-1210	-1150	-1060	
	(OLS = $V_{CC} - 0.8\text{ V}$, OLS = FLOAT)	-1750	-1630	-1510	-1715	-1595	-1475	-1685	-1565	-1445	
	(OLS = $V_{CC} - 1.2\text{ V}$)	-1040	-990	-910	-1010	-960	-880	-985	-935	-855	
	(OLS = V_{EE}) (Note 27)	-1515	-1425	-1305	-1480	-1390	-1270	-1450	-1360	-1240	
	$-3.0\text{ V} < V_{EE} \leq -2.375\text{ V}$										
	(OLS = V_{CC})	-1945	-1795	-1645	-1905	-1755	-1605	-1875	-1725	-1575	
	(OLS = $V_{CC} - 0.4\text{ V}$)	-1265	-1205	-1115	-1230	-1170	-1080	-1205	-1145	-1055	
	(OLS = $V_{CC} - 0.8\text{ V}$, OLS = FLOAT)	-1725	-1605	-1485	-1690	-1570	-1450	-1660	-1540	-1420	
	(OLS = $V_{CC} - 1.2\text{ V}$)	-1045	-995	-915	-1010	-960	-880	-990	-940	-860	
(OLS = V_{EE})	-1495	-1405	-1285	-1460	-1370	-1250	-1435	-1345	-1225		
V_{OUTPP}	Output Voltage Amplitude:										mV
	$-3.465\text{ V} \leq V_{EE} \leq -3.0\text{ V}$										
	(OLS = V_{CC})	705	815		695	805		690	800		
	(OLS = $V_{CC} - 0.4\text{ V}$)	130	220		125	215		125	215		
	(OLS = $V_{CC} - 0.8\text{ V}$, OLS = FLOAT)	535	640		530	635		525	630		
	(OLS = $V_{CC} - 1.2\text{ V}$)	0	0		0	0		0	0		
	(OLS = V_{EE}) (Note 27)	345	435		340	430		335	425		
	$-3.0\text{ V} < V_{EE} \leq -2.375\text{ V}$										
	(OLS = V_{CC})	670	800		660	795		655	790		
	(OLS = $V_{CC} - 0.4\text{ V}$)	125	215		120	210		120	210		
	(OLS = $V_{CC} - 0.8\text{ V}$, OLS = FLOAT)	510	615		505	610		500	605		
	(OLS = $V_{CC} - 1.2\text{ V}$)	0	5		0	0		0	5		
(OLS = V_{EE})	325	415		320	410		320	410			

DIFFERENTIAL CLOCK INPUTS DRIVEN SINGLE-ENDED (Figure 11 & 13) (Note 23)

V_{IH}	Input HIGH Voltage (Single-Ended) D, \bar{D} , SEL, \bar{SEL}	$V_{EE} + 1200$		V_{CC}	$V_{EE} + 1200$		V_{CC}	$V_{EE} + 1200$		V_{CC}	mV
V_{IL}	Input LOW Voltage (Single-Ended) D, \bar{D} , SEL, \bar{SEL}	V_{EE}		$V_{IH} - 150$	V_{EE}		$V_{IH} - 150$	V_{EE}		$V_{IH} - 150$	mV
V_{th}	Input Threshold Reference Voltage Range (Note 24)	$V_{EE} + 950$		$V_{CC} - 75$	$V_{EE} + 950$		$V_{CC} - 75$	$V_{EE} + 950$		$V_{CC} - 75$	mV
V_{ISE}	Single-Ended Input Voltage ($V_{IH} - V_{IL}$)	150		2600	150		2600	150		2600	mV

NB7L86A

Table 12. DC CHARACTERISTICS, NECL INPUT WITH NECL OUTPUT

$V_{CC} = 0\text{ V}$; $V_{EE} = -3.465\text{ V}$ to -2.375 V , $T_A = -40^\circ\text{C}$ to $+85^\circ\text{C}$ (Note 21)

Symbol	Characteristics	-40°C			25°C			85°C			Unit
		Min	Typ	Max	Min	Typ	Max	Min	Typ	Max	
DIFFERENTIAL INPUTS DRIVEN DIFFERENTIALLY (Figure 12) (Note 25)											
V_{IHD}	Differential Input HIGH Voltage (D, \bar{D} , SEL, \bar{SEL})	$V_{EE} + 1200$		V_{CC}	$V_{EE} + 1200$		V_{CC}	$V_{EE} + 120$		V_{CC}	mV
V_{ILD}	Differential Input LOW Voltage (D, \bar{D} , SEL, \bar{SEL})	V_{EE}		$V_{CC} - 75$	V_{EE}		$V_{CC} - 75$	V_{EE}		$V_{CC} - 75$	mV
V_{ID}	Differential Input Voltage ($V_{IHD} - V_{ILD}$) (D, \bar{D} , SEL, \bar{SEL})	75		2600	75		2600	75		2600	mV
V_{IHCMR}	Input HIGH Voltage Common Mode Range (Differential Configuration) (Note 26) (Figure 15)	$V_{EE} + 1200$		0	$V_{EE} + 1200$		0	$V_{EE} + 1200$		0	μA
I_{IH}	(Input HIGH Current (@ V_{IH}) D, \bar{D} , SEL, \bar{SEL})		30	100		30	100		30	100	μA
			5	50		5	50		5	50	
I_{IL}	(Input LOW Current (@ V_{IL}) D, \bar{D} , SEL, \bar{SEL})		20	100		20	100		20	100	μA
			5	50		5	50		5	50	

TERMINATION RESISTORS

R_{TIN}	Internal Input Termination Resistor	45	50	55	45	50	55	45	50	55	Ω

Product parametric performance is indicated in the Electrical Characteristics for the listed test conditions, unless otherwise noted. Product performance may not be indicated by the Electrical Characteristics if operated under different conditions.

NOTE: Device will meet the specifications after thermal equilibrium has been established when mounted in a test socket or printed circuit board with maintained transverse airflow greater than 500 lfm.

21. Input and output parameters vary 1:1 with V_{CC} .

22. LVPECL outputs loaded with $50\ \Omega$ to $(V_{CC} - 2\text{ V})$ for proper operation.

23. V_{th} , V_{IH} , V_{IL} , and V_{ISE} parameters must be complied with simultaneously.

24. V_{th} is applied to the complementary input when operating in single-ended mode. $V_{th} = (V_{IH} - V_{IL}) / 2$.

25. V_{IHD} , V_{ILD} , V_{ID} and V_{CMR} parameters must be complied with simultaneously.

26. V_{IHCMR} min varies 1:1 with V_{EE} , V_{IHCMR} max varies 1:1 with V_{CC} . The V_{IHCMR} range is referenced to the most positive side of the differential input signal.

27. When an output level of 400 mV is desired and $V_{CC} - V_{EE} > 3.0\text{ V}$, a 2 k Ω resistor should be connected from OLS to V_{EE} .

NB7L86A

Table 13. AC CHARACTERISTICS $V_{CC} = 0\text{ V}$; $V_{EE} = -3.465\text{ V to } -2.375\text{ V}$ or $V_{CC} = 2.375\text{ V to } 3.465\text{ V}$; $V_{EE} = 0\text{ V}$

Symbol	Characteristic		-40°C			25°C			85°C			Unit
			Min	Typ	Max	Min	Typ	Max	Min	Typ	Max	
f_{max}	Maximum Input Clock Frequency (See Figure 7) (Note 28)		7	8		7	8		7	8		GHz
V_{OUTPP}	Output Voltage Amplitude (OLS = V_{CC})	$f_{in} < 7\text{ GHz}$	590	730		470	720		540	700		mV
		$f_{in} = 8\text{ GHz}$	270	440		230	420		180	390		mV
t_{PLH}	Propagation Delay to Output Differential (Figure 15) D/SEL → Q		110	160	210	115	165	215	120	170	220	ps
t_{PHL}												
t_{SKEW}	Duty Cycle Skew (Note 29)			5	15		5	15		5	15	ps
t_{SKEW}	Channel Skew	Q → D/SEL		5	20		5	20		5	20	ps
t_S	Set-Up Time (Dx to SEL)		30			30			30			ps
t_H	Hold-Up Time (Dx to SEL)		35			35			35			ps
t_{JITTER}	RMS Random Clock Jitter (See Figure 7) (Note 31) $f_{in} \leq 7\text{ GHz}$ Peak-to-Peak Data Dependent Jitter (Note 32) $f_{in} \leq 7\text{ Gb/s}$			0.5	1.5		0.5	1.5		0.5	1.5	ps
				12			12			12		
V_{INPP}	Input Voltage Swing/Sensitivity (Differential Configuration) (Note 30)		75		1890	75		1890	75		1890	mV
t_r, t_f	Output Rise/ Fall Times		30	45	65	30	45	65	30	45	65	ps
	(20% – 80%) (Q, \bar{Q}) @ 1 GHz											

28. Measured using a 500 mV source, 50% duty cycle clock source. All loading with $50\ \Omega$ to $V_{CC} - 2.0\text{ V}$. Input edge rates 40 ps (20% – 80%).

29. $t_{SKEW} = |t_{PLH} - t_{PHL}|$ for a nominal 50% differential clock input waveform. See Figure 15.

30. V_{INPP} (max) cannot exceed $V_{CC} - V_{EE}$.

31. Additive RMS jitter with 50% duty cycle clock signal at 7 GHz.

32. Additive Peak-to-Peak data dependent jitter with NRZ PRBS $2^{31}-1$ data rate at 7 Gb/s.

NB7L86A

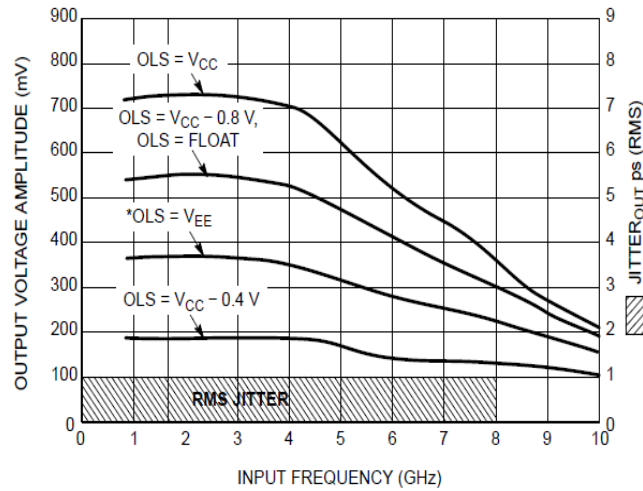

Figure 7. ($V_{CC} - V_{EE} = 2.5 \text{ V}$ @ 25°C)

NOTE: Output Voltage Amplitude (V_{OUTPP}) / RMS Jitter vs. Input Frequency (f_{in}) for 2:1 MUX Mode, Repetitive 1010 Input Data Pattern.
 *When an output level of 400 mV is desired and $V_{CC} - V_{EE} > 3.0 \text{ V}$, a $2 \text{ k}\Omega$ resistor should be connected from OLS to V_{EE} .

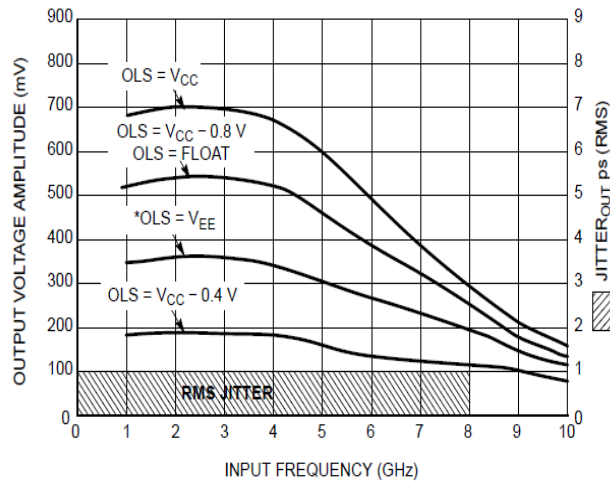

Figure 8. ($V_{CC} - V_{EE} = 3.3 \text{ V}$ @ 25°C)

NOTE: Output Voltage Amplitude (V_{OUTPP}) / RMS Jitter vs. Input Frequency (f_{in}) for 2:1 MUX Mode, Repetitive 1010 Input Data Pattern.
 *When an output level of 400 mV is desired and $V_{CC} - V_{EE} > 3.0 \text{ V}$, a $2 \text{ k}\Omega$ resistor should be connected from OLS to V_{EE} .

NB7L86A

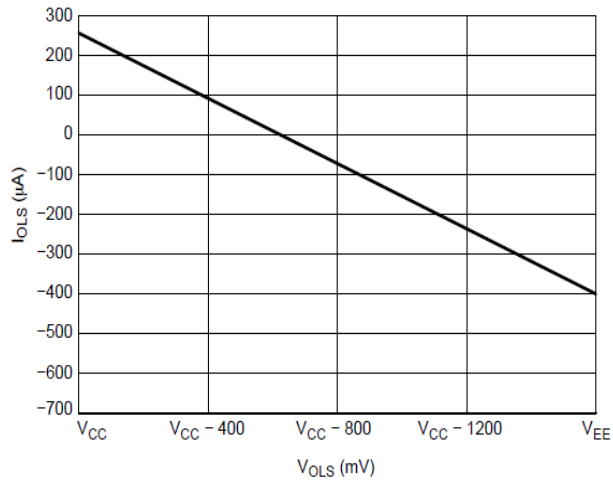

Figure 9. Typical OLS Input Current vs. OLS Input Voltage
 $(V_{CC} - V_{EE} = 3.3 \text{ V @ } 25^{\circ}\text{C})$

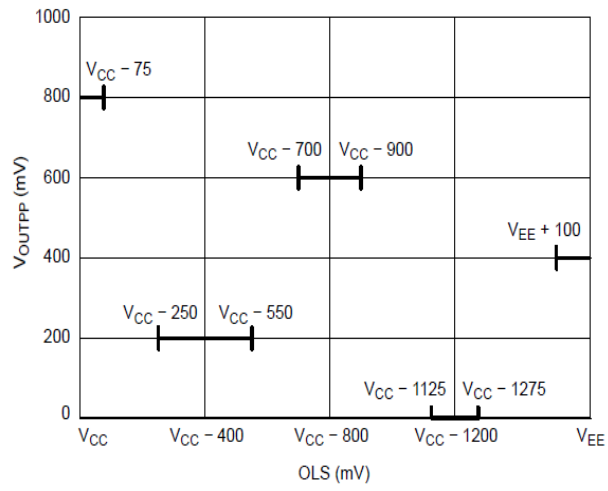

Figure 10. OLS Operating Area

NB7L86A

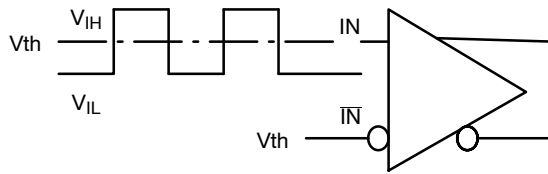

Figure 11. Differential Input Driven Single Ended

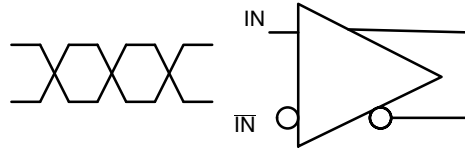

Figure 12. Differential Input Driven Differentially

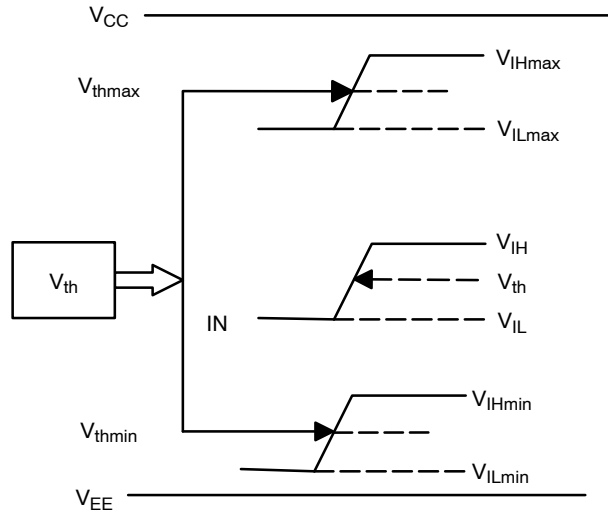

Figure 13. V_{TH} Diagram

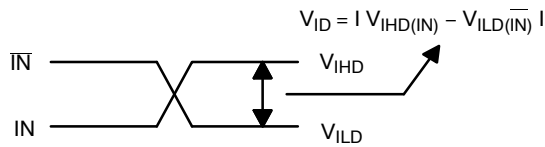

Figure 14. Differential Inputs Driven Differentially

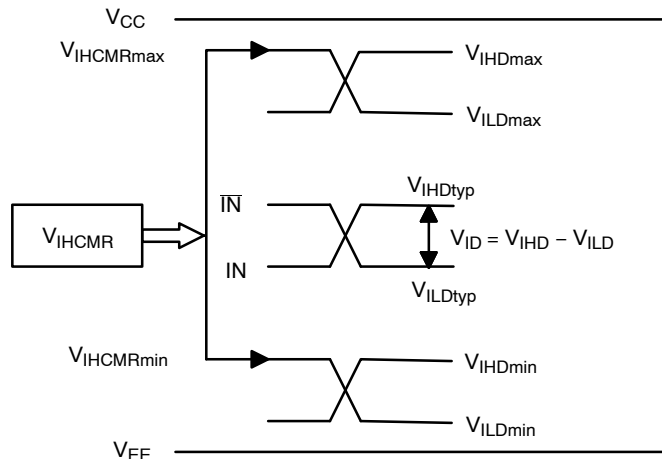

Figure 15. V_{IHCMR} Diagram

NB7L86A

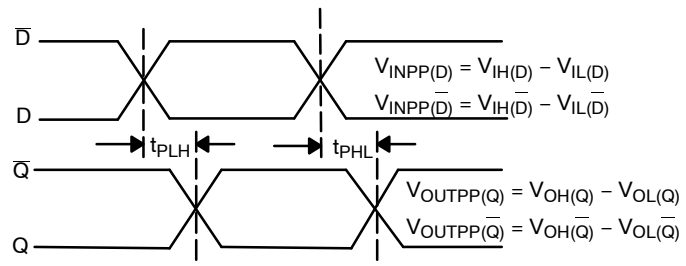

Figure 16. AC Reference Measurement

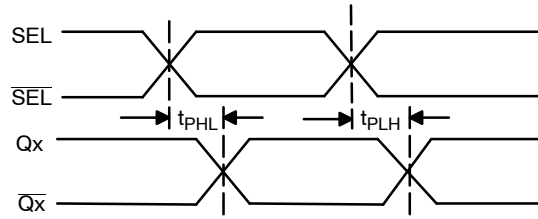

Figure 17. SEL_x to Q_x Timing Diagram

NB7L86A

APPLICATION INFORMATION

All NB7L86A inputs can accept PECL, CML, LVTTTL, LVCMOS and LVDS signal levels. The limitations for differential input signal (LVDS, PECL, or CML) are minimum input swing of 75 mV and the maximum input swing of 2500 mV. Within these conditions, the input

voltage can range from V_{CC} to 1.2 V. Examples interfaces are illustrated below in a $50\ \Omega$ environment ($Z = 50\ \Omega$). For output termination and interface, refer to application note AND8020/D.

Table 14. INTERFACING OPTIONS

INTERFACING OPTIONS	CONNECTIONS
CML	Connect VTD and VTD to V_{CC} (refer Figure 18)
LVDS	Connect VTD and VTD together. (refer Figure 19)
AC-COUPLED	Bias VTD and VTD inputs within the Common Mode range (V_{CMR}) (refer Figure 20)
RSECL, PECL, NECL	Standard ECL termination techniques (refer Figure 21)
LVTTTL, LVCMOS	An external voltage (V_{THR}) should be applied to the unused complementary differential input. Nominal V_{THR} is 1.5 V for LVTTTL and $V_{CC}/2$ for LVCMOS inputs. This voltage must be within the V_{THR} specification (refer Figure 22)

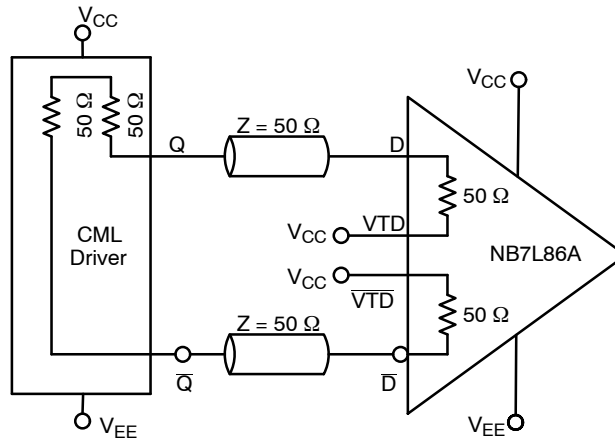

Figure 18. CML Interface

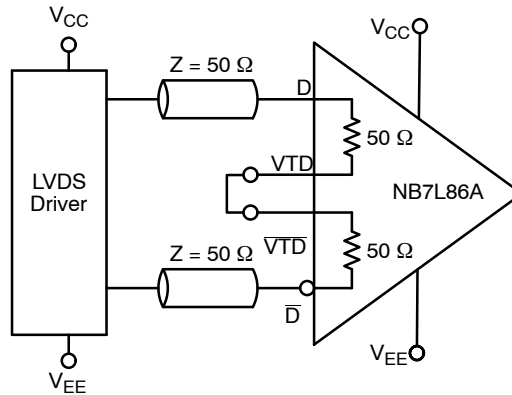

Figure 19. LVDS Interface

NB7L86A

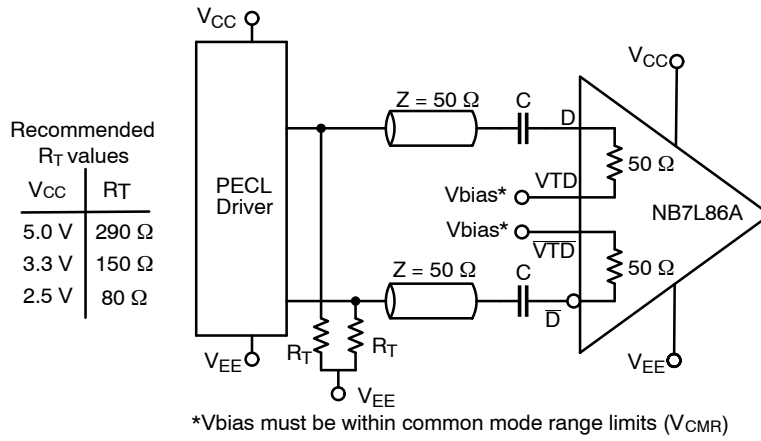

Figure 20. PECL Interface

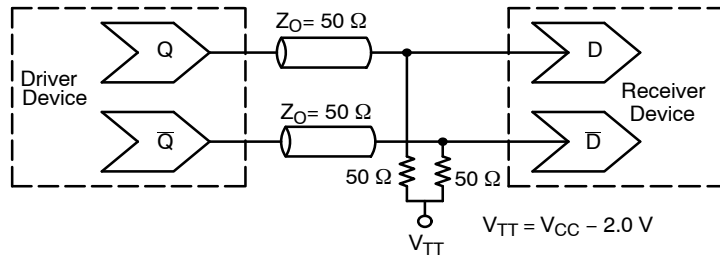

Figure 21. Typical termination for Output Driver and Device Evaluation (refer AND8020/D – termination of ECL Logic Devices)

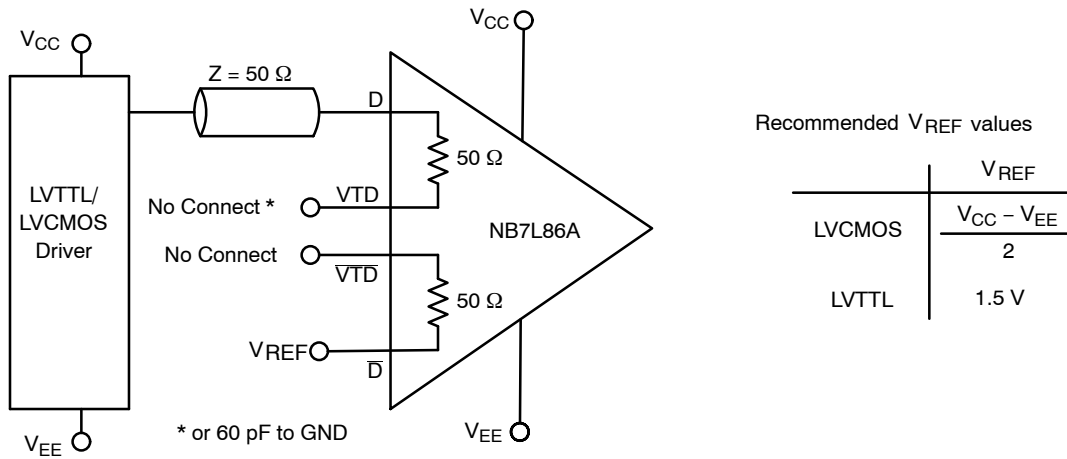

Figure 22. LVCMOS/LVTTL Interface

NB7L86A

ORDERING INFORMATION

Device	Package Type	Shipping†
NB7L86AMNG	QFN16 (Pb-Free / Halide-Free)	123 Units / Rail
NB7L86AMNHTBG	QFN16 (Pb-Free / Halide-Free)	100 / Tape & Reel

†For information on tape and reel specifications, including part orientation and tape sizes, please refer to our Tape and Reel Packaging Specifications Brochure, BRD8011/D.

GigaComm is a trademark of Semiconductor Components Industries, LLC dba "onsemi" or its affiliates and/or subsidiaries in the United States and/or other countries.

MECHANICAL CASE OUTLINE PACKAGE DIMENSIONS



SCALE 2:1

QFN16 3x3, 0.5P
CASE 485G
ISSUE G

DATE 08 OCT 2021

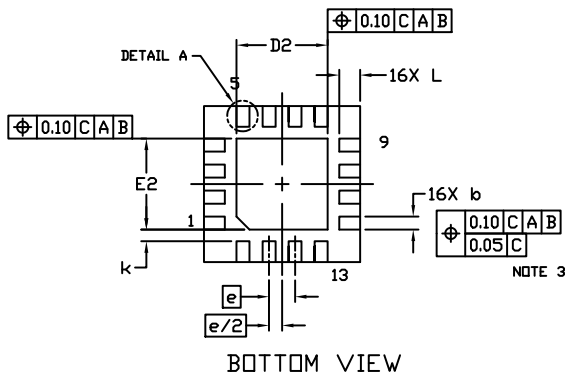
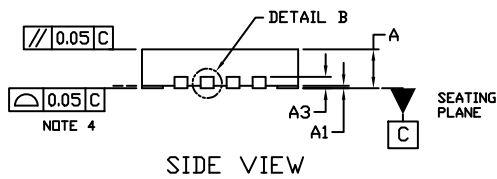
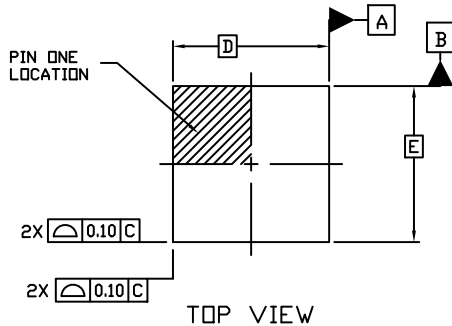

NOTES:

1. DIMENSIONING AND TOLERANCING PER ASME Y14.5M, 1994.
2. CONTROLLING DIMENSION: MILLIMETERS
3. DIMENSION *b* APPLIES TO PLATED TERMINAL AND IS MEASURED BETWEEN 0.15 AND 0.30 MM FROM THE TERMINAL TIP.
4. COPLANARITY APPLIES TO THE EXPOSED PAD AS WELL AS THE TERMINALS.

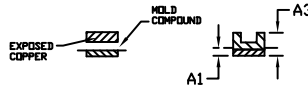

DETAIL B
ALTERNATE
CONSTRUCTIONS

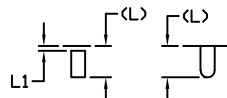

DETAIL A
ALTERNATE TERMINAL
CONSTRUCTIONS

DIM	MILLIMETERS		
	MIN.	NDM.	MAX.
A	0.80	0.90	1.00
A1	0.00	0.03	0.05
A3	0.20 REF		
<i>b</i>	0.18	0.24	0.30
D	3.00 BSC		
D2	1.65	1.75	1.85
E	3.00 BSC		
E2	1.65	1.75	1.85
<i>e</i>	0.50 BSC		
<i>k</i>	0.18 TYP		
L	0.30	0.40	0.50
L1	0.00	0.08	0.15

MOUNTING FOOTPRINT

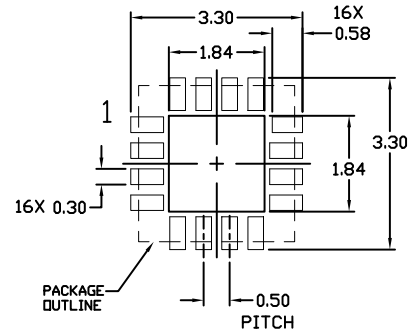

GENERIC MARKING DIAGRAM*

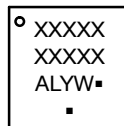

- XXXXX = Specific Device Code
- A = Assembly Location
- L = Wafer Lot
- Y = Year
- W = Work Week
- = Pb-Free Package

(Note: Microdot may be in either location)

*This information is generic. Please refer to device data sheet for actual part marking. Pb-Free indicator, "G" or microdot "▪", may or may not be present. Some products may not follow the Generic Marking.

DOCUMENT NUMBER:	98AON04795D	Electronic versions are uncontrolled except when accessed directly from the Document Repository. Printed versions are uncontrolled except when stamped "CONTROLLED COPY" in red.
DESCRIPTION:	QFN16 3X3, 0.5P	PAGE 1 OF 1

onsemi and ONSEMI are trademarks of Semiconductor Components Industries, LLC dba onsemi or its subsidiaries in the United States and/or other countries. onsemi reserves the right to make changes without further notice to any products herein. onsemi makes no warranty, representation or guarantee regarding the suitability of its products for any particular purpose, nor does onsemi assume any liability arising out of the application or use of any product or circuit, and specifically disclaims any and all liability, including without limitation special, consequential or incidental damages. onsemi does not convey any license under its patent rights nor the rights of others.

onsemi, **Onsemi**, and other names, marks, and brands are registered and/or common law trademarks of Semiconductor Components Industries, LLC dba "**onsemi**" or its affiliates and/or subsidiaries in the United States and/or other countries. **onsemi** owns the rights to a number of patents, trademarks, copyrights, trade secrets, and other intellectual property. A listing of **onsemi**'s product/patent coverage may be accessed at www.onsemi.com/site/pdf/Patent-Marking.pdf. **onsemi** reserves the right to make changes at any time to any products or information herein, without notice. The information herein is provided "as-is" and **onsemi** makes no warranty, representation or guarantee regarding the accuracy of the information, product features, availability, functionality, or suitability of its products for any particular purpose, nor does **onsemi** assume any liability arising out of the application or use of any product or circuit, and specifically disclaims any and all liability, including without limitation special, consequential or incidental damages. Buyer is responsible for its products and applications using **onsemi** products, including compliance with all laws, regulations and safety requirements or standards, regardless of any support or applications information provided by **onsemi**. "Typical" parameters which may be provided in **onsemi** data sheets and/or specifications can and do vary in different applications and actual performance may vary over time. All operating parameters, including "Typicals" must be validated for each customer application by customer's technical experts. **onsemi** does not convey any license under any of its intellectual property rights nor the rights of others. **onsemi** products are not designed, intended, or authorized for use as a critical component in life support systems or any FDA Class 3 medical devices or medical devices with a same or similar classification in a foreign jurisdiction or any devices intended for implantation in the human body. Should Buyer purchase or use **onsemi** products for any such unintended or unauthorized application, Buyer shall indemnify and hold **onsemi** and its officers, employees, subsidiaries, affiliates, and distributors harmless against all claims, costs, damages, and expenses, and reasonable attorney fees arising out of, directly or indirectly, any claim of personal injury or death associated with such unintended or unauthorized use, even if such claim alleges that **onsemi** was negligent regarding the design or manufacture of the part. **onsemi** is an Equal Opportunity/Affirmative Action Employer. This literature is subject to all applicable copyright laws and is not for resale in any manner.

ADDITIONAL INFORMATION

TECHNICAL PUBLICATIONS:



Technical Library: www.onsemi.com/design/resources/technical-documentation
onsemi Website: www.onsemi.com

ONLINE SUPPORT: www.onsemi.com/support

For additional information, please contact your local Sales Representative at www.onsemi.com/support/sales

Looking for pricing, stock, or lifecycle information?

Click below to explore more details on WIN SOURCE:

-  [View NB7L86AMNG on WIN SOURCE](#)
-  [ON Semiconductor](#) Information

Optimize Your Supply Chain with WIN SOURCE Solutions

-  Global Sourcing Solution
-  Obsolete Management
-  Cost Control Management
-  Shortage Management
-  Alternative Solution
-  Excess Inventory Management