



**THE DATASHEET OF
ABL005-00E**



ABL/AKL-Series Gear-Tooth Sensors

Block Diagrams

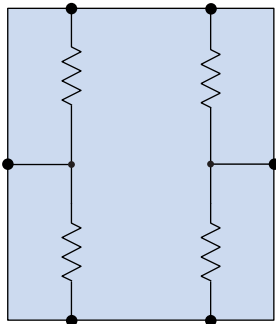

ABL00x

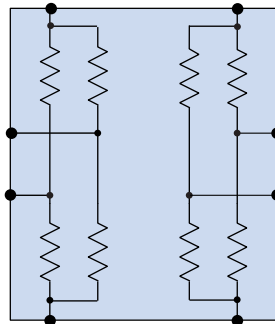

ABL01x

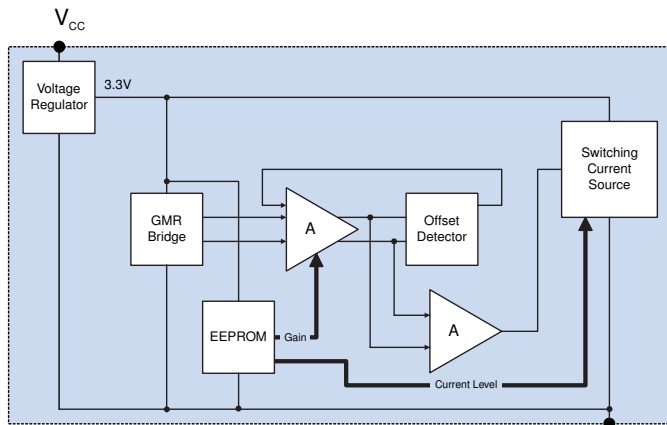

AKL00x

GND

Outputs

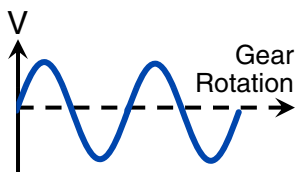

ABL00x
Single-bridge analog sensor

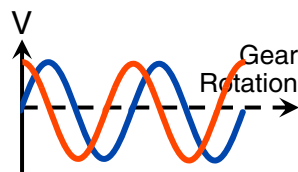

ABL01x
Dual-bridge analog sensor

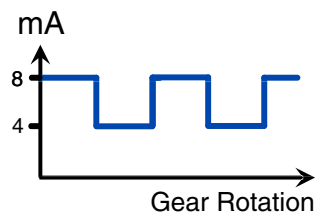

AKL00x digital gear-tooth sensor

Features

- Wide airgap
- Analog and digital versions
- Large analog peak-to-peak signal
- Single- and dual-bridge versions
- Operating frequency to 1 MHz
- 150 °C operating temperature
- Packages as small as 2.5 mm x 2.5 mm

Applications

- Motion, speed, and position sensing
- Linear and rotational encoders
- Closed-loop servo systems
- Automotive sensors

Description

ABL and AKL-Series Gear-Tooth Sensors are versatile, wide airgap sensors typically used with ferromagnetic gears and bias magnets.

Three standard spacings are available for use with gear pitches as small as 0.5 mm, to 6 mm or more (0.16 mm to 2 mm module).

ABL-Series analog sensors have differential sensor elements that provide sinusoidal outputs. Single- or dual-bridge configurations are available. Dual-bridge versions provide two phase-shifted outputs for A/B phase detection and absolute position interpolation.

AKL-Series sensors combine a sensor bridge with integrated signal processing to provide a 50% duty cycle digital output. Integrated signal processing includes gain and offset normalization. AKL-Series sensors are configured as two-wire devices, where the supply current indicates passing teeth.

Absolute Maximum Ratings

ABL-Series Analog Gear-Tooth Sensors			
Parameter	Min.	Max.	Units
Supply voltage		30	Volts
Storage temperature	-65	170	°C
ESD (Human Body Model)		400	Volts
Applied magnetic field		Unlimited	Tesla

AKL-Series Digital Gear-Tooth Sensors			
Parameter	Min.	Max.	Units
Supply voltage	-60	45	Volts
Continuous output current		16	mA
Junction temperature	-40	170	°C
Storage temperature	-65	170	°C
Junction temperature	-40	170	°C
ESD (Human Body Model)		2000	Volts
Applied magnetic field		Unlimited	Tesla

Operating Specifications

ABL-Series Analog Gear-Tooth Sensors						
Parameter	Symbol	Min.	Typ.	Max.	Units	Test Condition
Operating temperature	$T_{\min}; T_{\max}$	-50		150	°C	
Supply voltage	V_{CC}	0		30	V	
Resistance		4	5	7	k Ω	At 25 °C
Offset voltage	V_O	-4		+4	mV/V	
Non-linearity				2	%	Unipolar field sweep through operating range
Hysteresis				2	%	
Saturation of GMR sensor elements		-18		+18	mT	
Single resistor sensitivity	$\Delta R/mT$		0.4		%/mT	
Maximum output			80		mV/V	
Resistance temperature coefficient	TCR		+0.11		%/°C	No applied field
Operating frequency	f_{MAX}	0	1		MHz	

AKL-Series Digital Gear-Tooth Sensors (T_{\min} to T_{\max} ; 4.5 V < V_{CC} < 36 V unless otherwise stated)						
Parameter	Symbol	Min.	Typ.	Max.	Units	Test Condition
Operating temperature	$T_{\min}; T_{\max}$	-40		150	°C	
Supply voltage	V_{CC}	4.5		36	V	
Off-state supply current	I_{OFF}	3.4	4	4.8	mA	$V_{CC} = 12 V$
On-state supply current	I_{ON}	7	8	9		
Output duty cycle		40	50	60	%	
Airgap					mm	
AKL001-12E		1		3.5		
AKL002-12E		1		2.5		
AKL003-12E		1		2		
Operating frequency	f_{MAX}	DC		10	kHz	

Operation

Sensor orientation

To align with the axis of sensitivity, sensors should be oriented with the gear teeth perpendicular to the length of the sensor as shown in Figure 1:

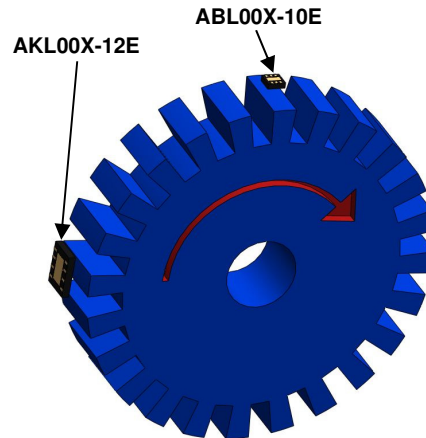

Figure 1. Sensor orientation.

Biasing

To detect gear teeth, a permanent magnet is required to generate a magnetic bias field. The sensor can then detect magnetic field variations as the gear tooth passes by.

Here are some tips for biasing:

- Because of GT Sensors' high sensitivity, small, inexpensive Ceramic 8 ferrite magnets can be used for most applications. Small sensors and magnets allow small circuit boards.
- Alnico 8 magnets can be used in high temperature applications.
- When using rare-earth magnets, care should be taken to avoid saturating the sensors.
- Magnets and sensors can be placed on opposite sides of a 1.5 mm thick (0.062 inch) circuit board, which provides a convenient spacing for many applications (see Figure 2).
- The magnet can be glued to the circuit board using high-temperature epoxy adhesive.
- For more precise positioning, a pocket to hold the magnet can be machined into a thicker circuit board.
- If zero speed operation is not required, AC coupling the sensor removes the electrical offset induced by magnetic imperfections.

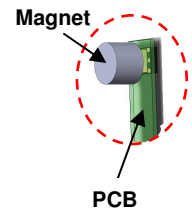

Figure 2. Biasing magnet.

Recommended sensor element spacing vs. gear pitch

For ABL00x and AKL00x sensors, the best design margin is when the sensor element spacing is equal to approximately one-half the gear pitch. For example, this means the one-millimeter pitch ABL004 is ideal for two-millimeter pitch (0.65 mm module) gears.

For ABL01x sensors, the relative phase of the A/B outputs is determined by the ratio of the bridge phase difference and the gear pitch:

$$\text{Phase Shift} = (\text{bridge phase shift} / \text{gear pitch}) \cdot 360^\circ$$

As an example, the A/B phase difference for an ABL015 detecting a 1.2 mm gear pitch is equal to $(0.25 / 1.2) \cdot 360^\circ = 75^\circ$.

Design Support

Check out our free Web application for GT sensor design support:

<https://www.nve.com/spec/calculators.php#tabs-GT-Sensor-Output>

Sinusoidal output with rotation

As shown in Figure 3 below, a biasing magnet provides a field, and the magnetic flux lines are deflected into the direction of sensitivity by passing metal gear teeth. Sensors are placed between the magnet and gear teeth. Thus the sensor produces a sinusoidal output with one cycle per tooth.

Dual-bridge sensors provide a second bridge output that is out-of-phase with the first sensor.

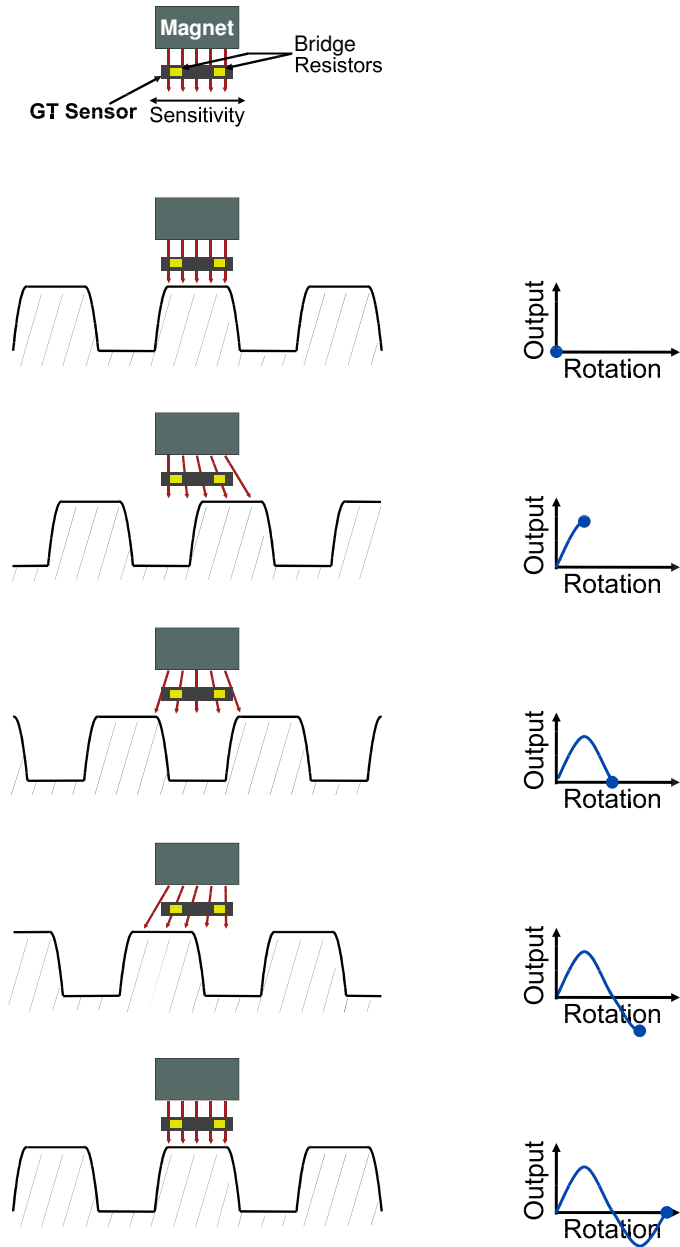

Figure 3. ABL00x output vs. gear rotation.

Typical outputs

Figures 4 to 6 show typical outputs from each of the three GT Sensor types:

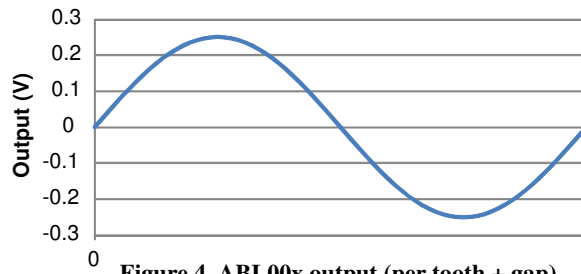

Figure 4. ABL00x output (per tooth + gap)

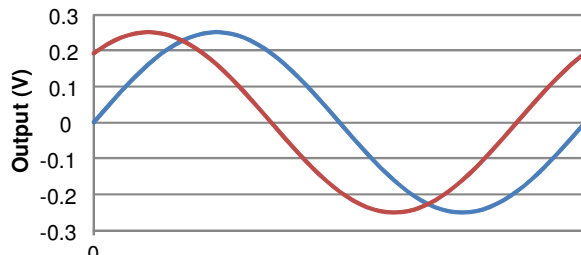

Figure 5. ABL01x output (per tooth + gap)

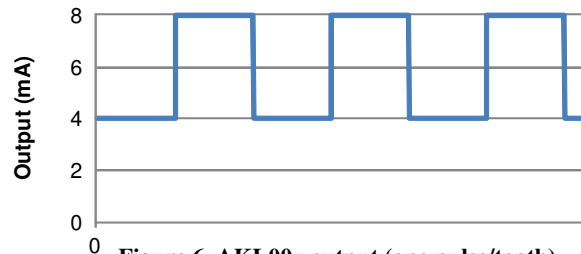

Figure 6. AKL00x output (one pulse/tooth)

Illustrative Application Circuits

Digital output from analog gear-tooth sensors

A comparator can be used to provide a digital signal corresponding to each gear passing:

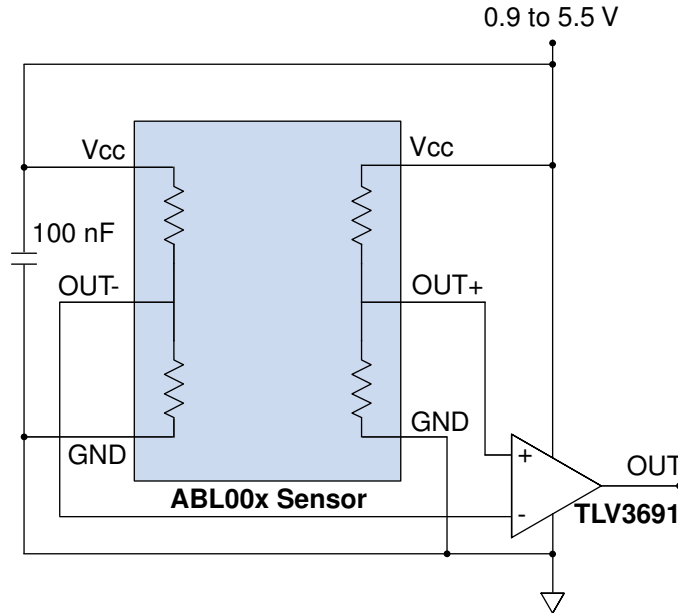

Figure 7. Digital output from an analog sensor.

If zero speed operation is not required, AC coupling the sensor remove offset induced by magnetic imperfections.

Digital Speed and Direction Signals

ABL01x dual-element sensors provide two outputs that can indicate direction of rotation. A dual comparator and flip-flop can provide direction and speed outputs. Direction is determined by detecting the phasing between the two outputs. The “Speed” output is one cycle per tooth:

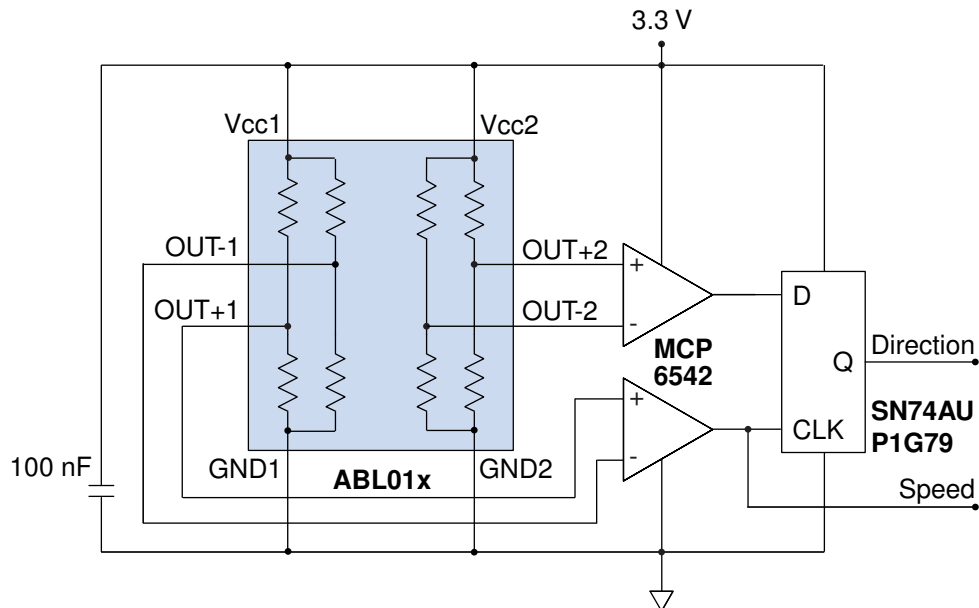

Figure 8. Digital speed and direction signals for gear-tooth sensors.

AKL sensor typical operation

A single resistor in series with the sensor can detect the digital output. A 100Ω resistor provides a 400 mV peak-to-peak signal.

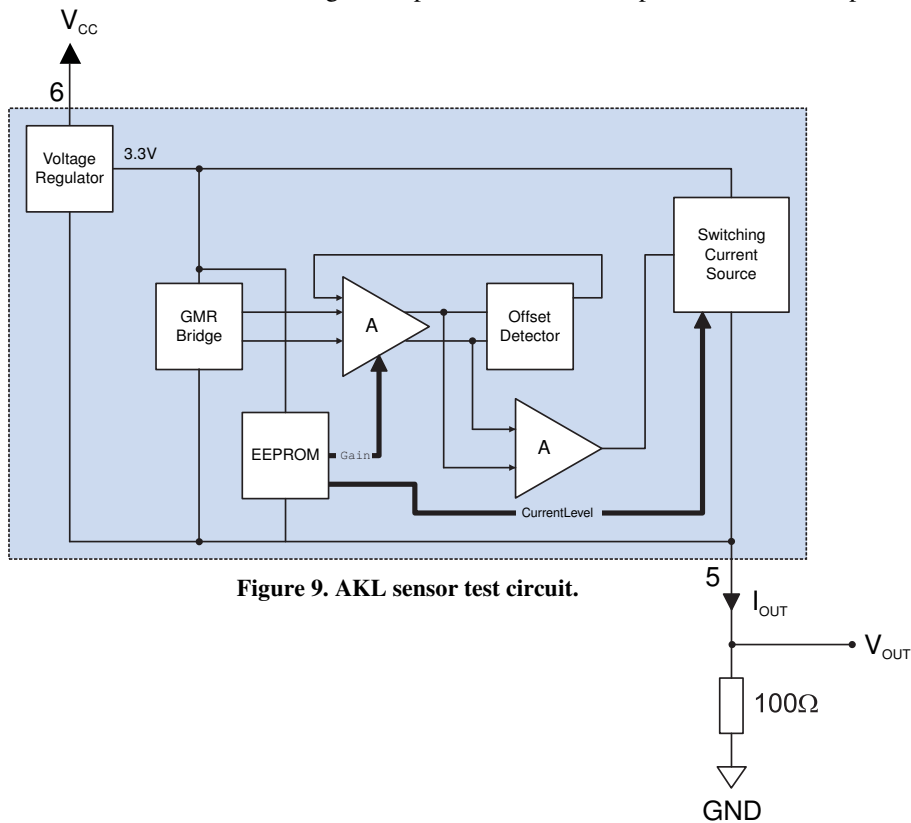

Figure 9. AKL sensor test circuit.

Three-Wire Digital Gear-Tooth Sensor

The two-wire AKL-Series can be easily converted to a three-wire interface:

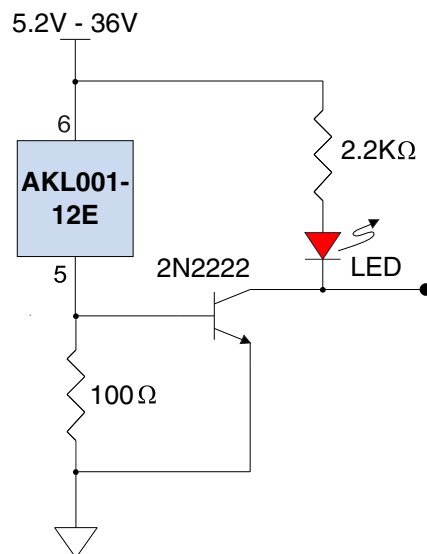

Figure 10. Simple three-wire interface.

When the current is 4 mA, the voltage across the 100Ω resistor is 0.4 V, which is not enough to turn on the transistor. With 8 mA, the transistor turns on. Note that the supply voltage must be at least 5.2 V to provide the sensor's 4.5 V minimum Vcc. The LED is optional.

TTL Output Gear-Tooth Sensor

The circuit below uses a simple comparator (7211 or similar) to convert the 4 to 8 mA AKL supply current to a rail-to-rail digital output.

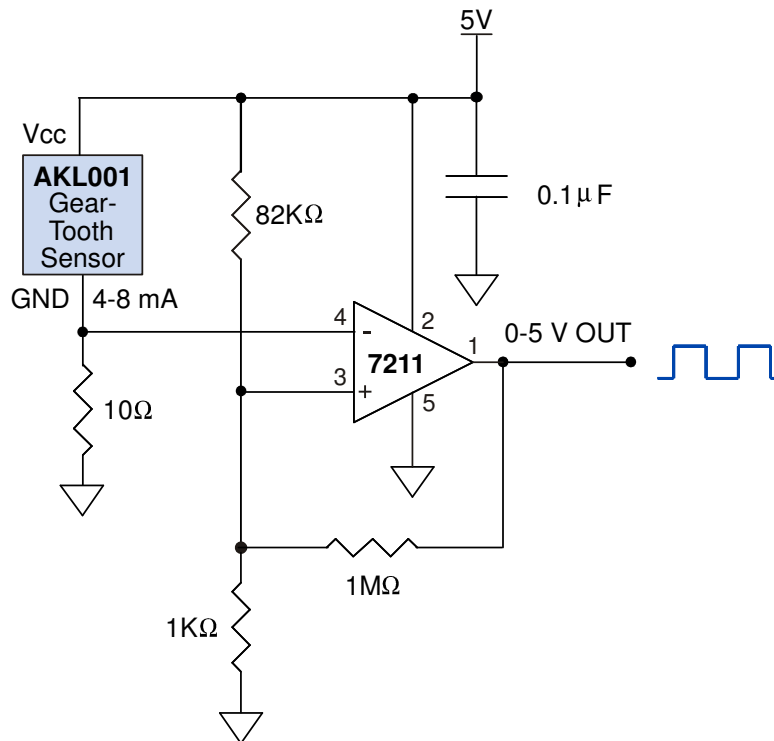
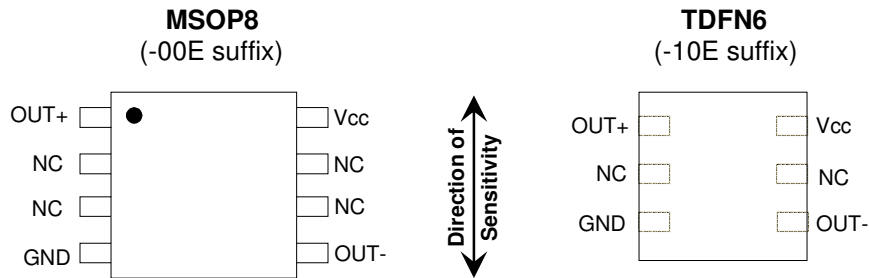

Figure 11. TTL output gear-tooth sensor.

The 10Ω series resistor is small enough to ensure the sensor Vcc voltage is above its 4.5 V minimum with a 4.75 to 5.25 V supply. The 1 KΩ and 82 KΩ resistors set a comparator threshold between 4 and 8 mA, and the 1 MΩ resistor provides hysteresis to enhance noise immunity.

ABL00X-XXE (single bridge) pinouts



Pin		Symbol	Description
MSOP8	TDFN6		
8	6	V _{CC}	Power supply
4	3	GND	Ground
1	1	OUT+	Bridge differential output
5	4	OUT-	
2, 3, 6, 7	2, 5	NC	No internal connection

ABL01X-XXE (dual bridge) pinouts

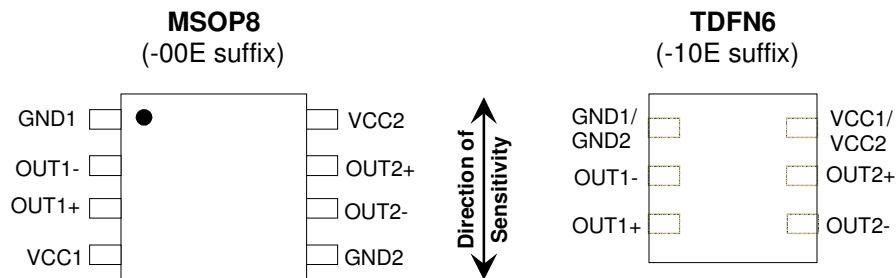

Pin		Symbol	Description
MSOP8	TDFN6		
4	6	V _{CC1}	Bridge 1 power supply
8		V _{CC2}	Bridge 2 power supply
1	1	GND1	Bridge 1 ground
5		GND2	Bridge 2 ground
2	2	OUT1-	Bridge 1 differential output
3	3	OUT1+	
6	4	OUT2-	Bridge 2 differential output
7	5	OUT2+	

OUT1 and OUT2 are A/B phase shifted outputs.

AKL-Series Pinout

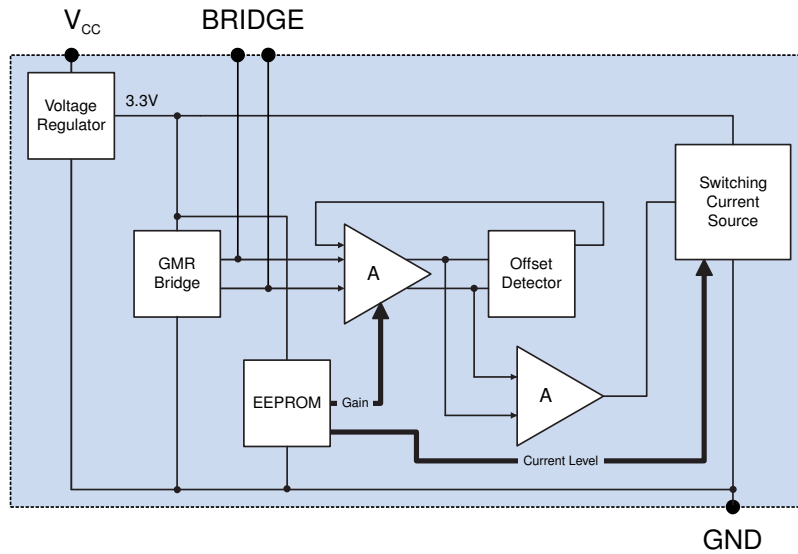

TDFN8 Pin	Symbol	Description
6	V _{CC}	Supply voltage
5	GND	Ground
4	BRIDGE+	Bridge outputs (leave floating for normal operation)
7	BRIDGE-	
1, 2, 3, 8	Test	No connections should be made for normal operation

Available Parts

ABL-Series Analog Gear-Tooth Sensors							
Part No.	Single or Dual Bridge	Element Spacing	Phase Shift Between Bridges	Recommended Gear Pitch	Recommended Gear Module	Package	Package Marking Code
ABL004-00E	Single	1 mm	NA	1.7 – 6 mm	0.5 – 2 mm	MSOP8	FDB
ABL005-00E	Single	0.5 mm	NA	0.8 – 1.7 mm	0.25 – 0.5 mm	MSOP8	FDC
ABL006-00E	Single	0.3 mm	NA	0.5 – 0.8 mm	0.16 – 0.25 mm	MSOP8	FDL
ABL014-00E	Dual	1 mm	0.5 mm	1.7 – 6 mm	0.5 – 2 mm	MSOP8	FDD
ABL015-00E	Dual	0.5 mm	0.25 mm	0.8 – 1.7 mm	0.25 – 0.5 mm	MSOP8	FDF
ABL016-00E	Dual	0.3 mm	0.15 mm	0.5 – 0.8 mm	0.16 – 0.25 mm	MSOP8	FDM
ABL004-10E	Single	1 mm	NA	1.7 – 6 mm	0.5 – 2 mm	TDFN6	FDG
ABL005-10E	Single	0.5 mm	NA	0.8 – 1.7 mm	0.25 – 0.5 mm	TDFN6	FDH
ABL006-10E	Single	0.3 mm	NA	0.5 – 0.8 mm	0.16 – 0.25 mm	TDFN6	FDN
ABL014-10E	Dual	1 mm	0.5 mm	1.7 – 6 mm	0.5 – 2 mm	TDFN6	FDJ
ABL015-10E	Dual	0.5 mm	0.25 mm	0.8 – 1.7 mm	0.25 – 0.5 mm	TDFN6	FDK
ABL016-10E	Dual	0.3 mm	0.15 mm	0.5 – 0.8 mm	0.16 – 0.25 mm	TDFN6	FDP

AKL-Series Digital Gear-Tooth Sensors				
Part No.	Element Spacing	Recommended Gear Pitch	Recommended Gear Module	Package
AKL001-12E	1 mm	1.7 – 6 mm	0.5 – 2 mm	TDFN8
AKL002-12E	0.5 mm	0.8 – 1.7 mm	0.25 – 0.5 mm	TDFN8
AKL003-12E	0.3 mm	0.5 – 0.8 mm	0.16 – 0.25 mm	TDFN8

Customer Support

Evaluation and Demonstration Boards

Inexpensive evaluation boards are available for the ABL- and AKL-Series GT sensors.



AG920-07—GT Sensor Evaluation Kit

Evaluate gear tooth sensors for measuring rotational speed with a variety of analog and digital GT Sensors, plus the DD001-12 stand-alone signal processing IC. A variety of PCB configurations are provided so the parts can be tested in different housing and barrel sizes, including the M8 housing. Biasing magnets are also included.



AG921-07—AKL002 Gear-Tooth Sensor Demonstrator

NVE's AG921-07 evaluation kit is a self-contained demonstrator for NVE's unique AKL digital gear tooth sensor. The battery-powered demonstrator (battery included) uses an AKL002 sensor to detect passing gear teeth. The demonstrator also includes a circuit board with an LED and driver, a biasing magnet, and a gear that can be turned by hand. No assembly required. Dimensions 3" x 3" x 1.5" (75 mm x 75 mm x 38 mm).

Demonstration Videos

NVE uploads regular new product and application demonstrations to *Youtube*; check out our channel:

www.YouTube.com/NveCorporation

Detecting tiny gear teeth with the ultraprecise ABL006:

youtu.be/brDLly1L6aE

ABL/AKL-Series GT Sensor oscilloscope demonstration:

youtu.be/7R3qPD51W2w

Handheld AKL002 demonstration:

youtu.be/sAA3ILHs7h4

Application Note

Best practices and design support for NVE GT Sensors:

https://www.nve.com/Downloads/SB-00-103_GT-Sensor-App-Note.pdf

Design Assistance Web-Application

We have a free web-based application to provide design support for ABL Series GT Sensors, including bias magnet selection. Enter your gear's dimensions, then choose your sensor, bias magnet, and PCB thickness and view approximate sensor outputs for your system:

<https://www.nve.com/spec/calculators.php#tabs-GT-Sensor-Output>

Bare Circuit Boards and Magnets for Sensors

PCBs

NVE offers several bare circuit boards specially designed for easy connections to GT Sensors. Popular PCBs are shown below (images are actual size):



AG915-06:
0.25" (6 mm) octagonal
MSOP8



AG918-06 (standard) / **AG919-06** (cross-axis):
2" x 0.25" (50 mm x 6 mm) MSOP8



AG035-06:
1.57" x 0.25" (40 mm x 6 mm) TDFN6

Magnets

NVE offers three standard ferrite disk magnets for use with GT Sensors:

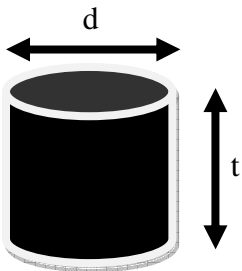

NVE Part #	Material	Diameter (d)	Thickness (t)
12031	C5/Y25	8 mm	3.2 mm
12216	C5/Y25	6 mm	4 mm
12217	C5/Y25	3.5 mm	4 mm

Package Drawings

MSOP8 (-00E suffix)

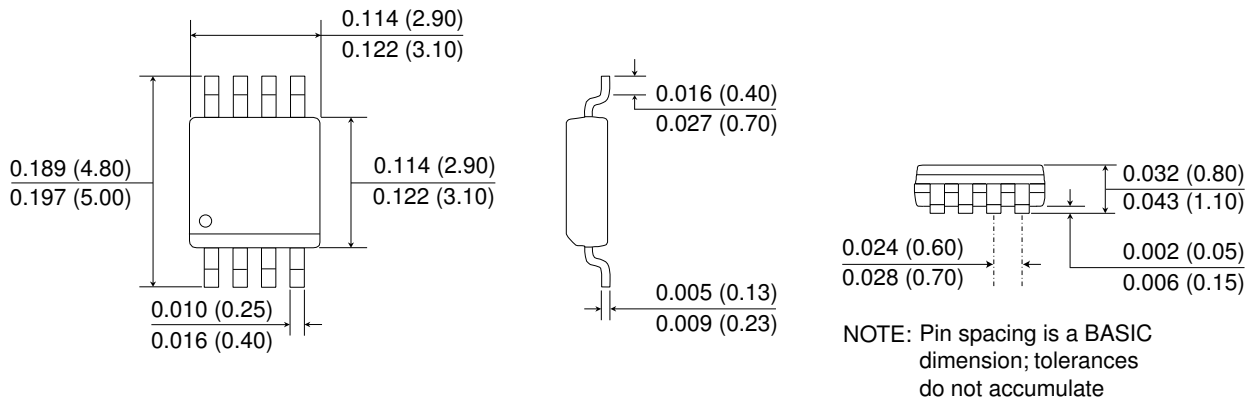

TDFN6 (-10E suffix)

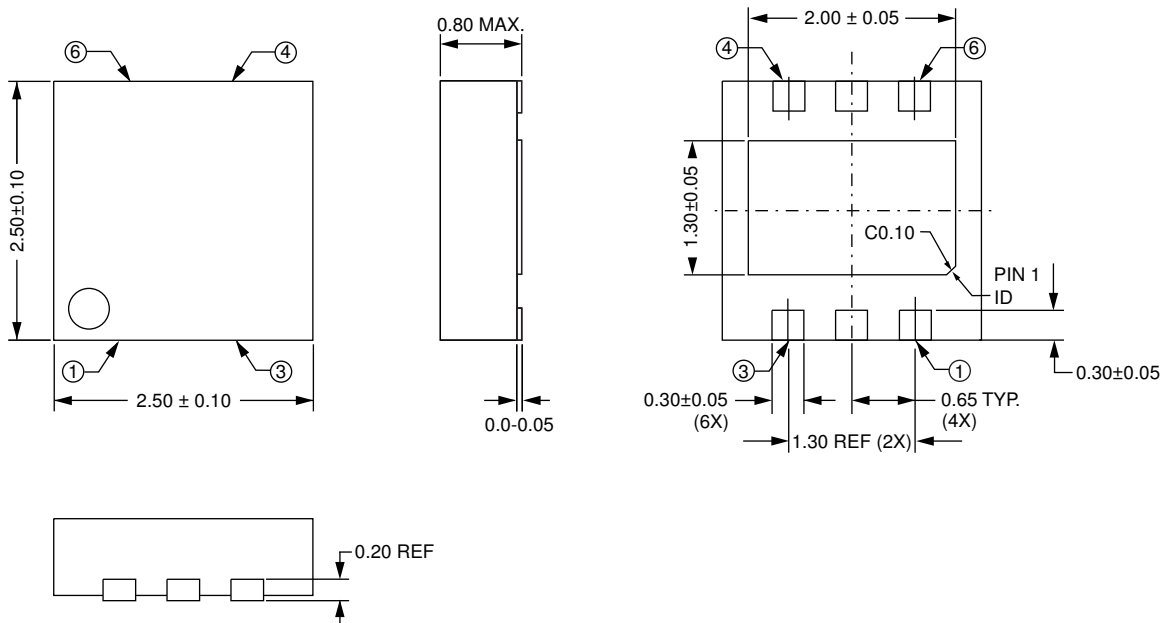

TDFN8 (-11E suffix)

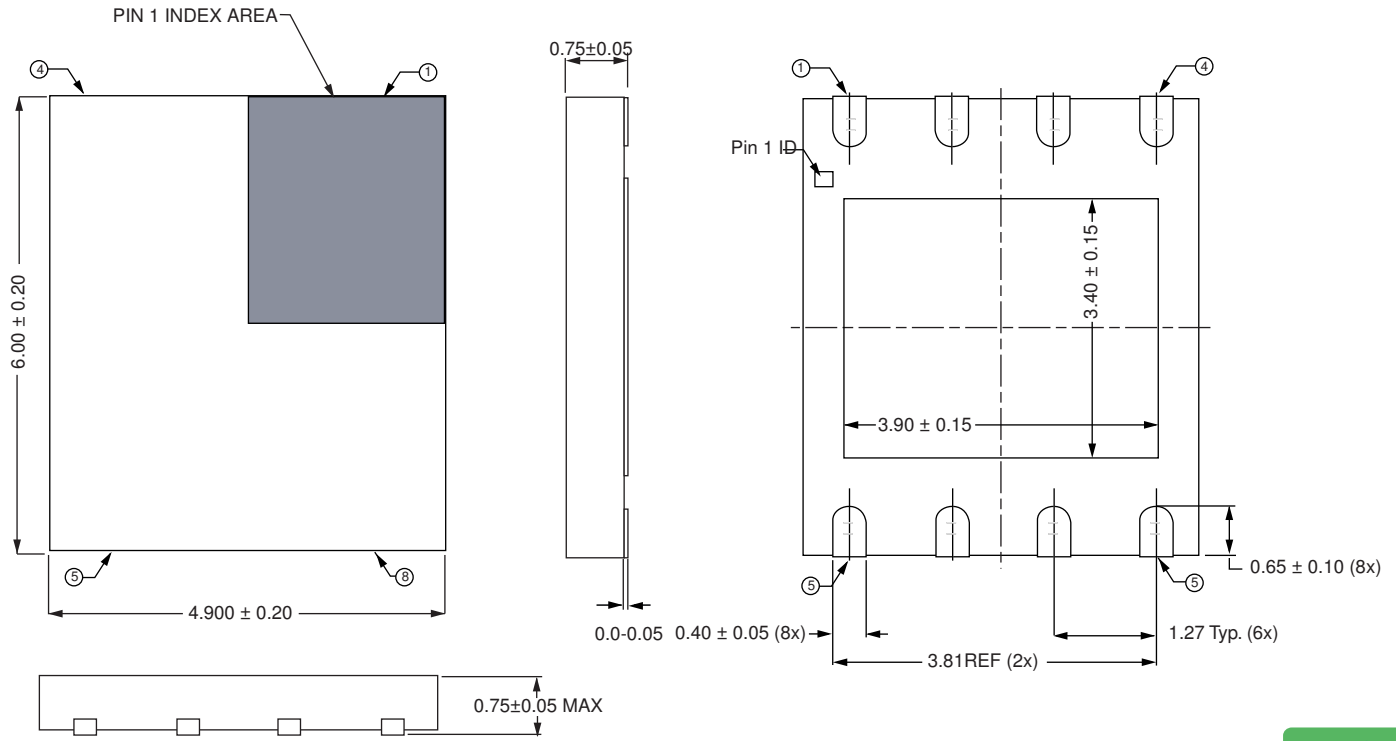

RoHS
COMPLIANT

All soldering profiles per JEDEC J-STD-020C, MSL 1.

Revision History

SB-00-061-C

November 2019

Change

- Clarified operating recommendations, updated customer support section.
- Added a “Recommended Gear Module” column to the “Available Parts” tables on p. 11.

SB-00-061-B

July 2018

Change

- Added E suffix to all part numbers in available parts table.

SB-00-061-A

March 2017

Change

- Initial datasheet release superseding catalog.

Datasheet Limitations

The information and data provided in datasheets shall define the specification of the product as agreed between NVE and its customer, unless NVE and customer have explicitly agreed otherwise in writing. All specifications are based on NVE test protocols. In no event however, shall an agreement be valid in which the NVE product is deemed to offer functions and qualities beyond those described in the datasheet.

Limited Warranty and Liability

Information in this document is believed to be accurate and reliable. However, NVE does not give any representations or warranties, expressed or implied, as to the accuracy or completeness of such information and shall have no liability for the consequences of use of such information.

In no event shall NVE be liable for any indirect, incidental, punitive, special or consequential damages (including, without limitation, lost profits, lost savings, business interruption, costs related to the removal or replacement of any products or rework charges) whether or not such damages are based on tort (including negligence), warranty, breach of contract or any other legal theory.

Right to Make Changes

NVE reserves the right to make changes to information published in this document including, without limitation, specifications and product descriptions at any time and without notice. This document supersedes and replaces all information supplied prior to its publication.

Use in Life-Critical or Safety-Critical Applications

Unless NVE and a customer explicitly agree otherwise in writing, NVE products are not designed, authorized or warranted to be suitable for use in life support, life-critical or safety-critical devices or equipment. NVE accepts no liability for inclusion or use of NVE products in such applications and such inclusion or use is at the customer's own risk. Should the customer use NVE products for such application whether authorized by NVE or not, the customer shall indemnify and hold NVE harmless against all claims and damages.

Applications

Applications described in this datasheet are illustrative only. NVE makes no representation or warranty that such applications will be suitable for the specified use without further testing or modification.

Customers are responsible for the design and operation of their applications and products using NVE products, and NVE accepts no liability for any assistance with applications or customer product design. It is customer's sole responsibility to determine whether the NVE product is suitable and fit for the customer's applications and products planned, as well as for the planned application and use of customer's third party customers. Customers should provide appropriate design and operating safeguards to minimize the risks associated with their applications and products.

NVE does not accept any liability related to any default, damage, costs or problem which is based on any weakness or default in the customer's applications or products, or the application or use by customer's third party customers. The customer is responsible for all necessary testing for the customer's applications and products using NVE products in order to avoid a default of the applications and the products or of the application or use by customer's third party customers. NVE accepts no liability in this respect.

Limiting Values

Stress above one or more limiting values (as defined in the Absolute Maximum Ratings System of IEC 60134) will cause permanent damage to the device. Limiting values are stress ratings only and operation of the device at these or any other conditions above those given in the recommended operating conditions of the datasheet is not warranted. Constant or repeated exposure to limiting values will permanently and irreversibly affect the quality and reliability of the device.

Terms and Conditions of Sale

In case an individual agreement is concluded only the terms and conditions of the respective agreement shall apply. NVE hereby expressly objects to applying the customer's general terms and conditions with regard to the purchase of NVE products by customer.

No Offer to Sell or License

Nothing in this document may be interpreted or construed as an offer to sell products that is open for acceptance or the grant, conveyance or implication of any license under any copyrights, patents or other industrial or intellectual property rights.

Export Control

This document as well as the items described herein may be subject to export control regulations. Export might require a prior authorization from national authorities.

Automotive Qualified Products

Unless the datasheet expressly states that a specific NVE product is automotive qualified, the product is not suitable for automotive use. It is neither qualified nor tested in accordance with automotive testing or application requirements. NVE accepts no liability for inclusion or use of non-automotive qualified products in automotive equipment or applications.

In the event that customer uses the product for design-in and use in automotive applications to automotive specifications and standards, customer (a) shall use the product without NVE's warranty of the product for such automotive applications, use and specifications, and (b) whenever customer uses the product for automotive applications beyond NVE's specifications such use shall be solely at customer's own risk, and (c) customer fully indemnifies NVE for any liability, damages or failed product claims resulting from customer design and use of the product for automotive applications beyond NVE's standard warranty and NVE's product specifications.

An ISO 9001 Certified Company

NVE Corporation
11409 Valley View Road
Eden Prairie, MN 55344-3617 USA
Telephone: (952) 829-9217

www.nve.com
e-mail: sensor-info@nve.com

©NVE Corporation
All rights are reserved. Reproduction in whole or in part is prohibited without the prior written consent of the copyright owner.

September 2023

Looking for pricing, stock, or lifecycle information?

Click below to explore more details on WIN SOURCE:

 [View ABL005-00E on WIN SOURCE](#)

 [NVE Corp Information](#)

Optimize Your Supply Chain with WIN SOURCE Solutions

-  Global Sourcing Solution
-  Obsolete Management
-  Cost Control Management
-  Shortage Management
-  Alternative Solution
-  Excess Inventory Management