



**THE DATASHEET OF
HCPL-0466-000E**



HCPL-4506/J456/0466, HCNW4506

Intelligent Power Module and Gate Drive Interface Optocouplers

Description

The Broadcom® HCPL-4506 and HCPL-0466 contain a GaAsP LED, while the Broadcom HCPL-J456 and the HCNW4506 contain an AlGaAs LED. The LED is optically coupled to an integrated high gain photo detector. Minimized propagation delay difference between devices makes these optocouplers excellent solutions for improving inverter efficiency through reduced switching dead time.

An on-chip 20-k Ω output pull-up resistor can be enabled by shorting output pins 6 and 7, thus eliminating the need for an external pull-up resistor in common IPM applications. Specifications and performance plots are given for typical IPM applications.

Figure 1: Functional Diagram

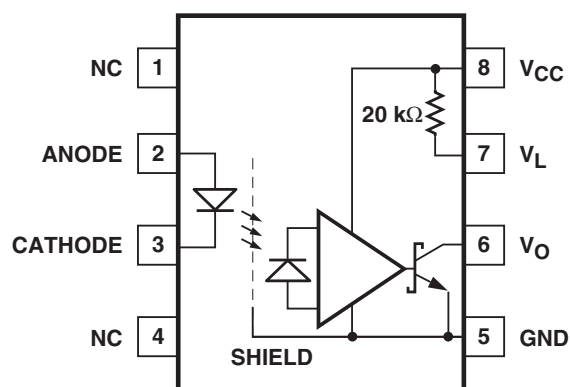

Table 1: Truth Table

LED	V _O
OFF	LOW
ON	HIGH

NOTE: A 0.1- μ F bypass capacitor must be connected between pins V_{CC} and V_{EE}.

Features

- Performance specified for common IPM applications over industrial temperature range: -40°C to 100°C
- Fast maximum propagation delays:
 - t_{PHL} = 480 ns
 - t_{PLH} = 550 ns
- Minimized pulse width distortion, PWD = 450 ns
- 15 kV/ μ s minimum common-mode transient immunity at V_{CM} = 1500V
- CTR > 44% at I_F = 10 mA
- Safety approvals:
 - UL recognized:
 - 3750 V_{rms} for 1 minute for HCPL-4506/0466/J456
 - 5000 V_{rms} for 1 minute for HCPL-4506 Option 020 and HCNW4506
 - CSA approved.
 - IEC/EN/DIN EN 60747-5-5 approved
 - V_{IORM} = 560 V_{peak} for HCPL-0466 Option 060
 - V_{IORM} = 630 V_{peak} for HCPL-4506 Option 060
 - V_{IORM} = 891 V_{peak} for HCPL-J456
 - V_{IORM} = 1414 V_{peak} for HCNW4506

Applications

- IPM isolation
- Isolated IGBT/MOSFET gate drive
- AC and brushless DC motor drives
- Industrial inverters

CAUTION! Take normal static precautions in handling and assembly this component to prevent damage and/or degradation that may be induced by ESD.

Selection Guide

Package Type	Standard 8-Pin DIP (300 Mil)	White Mold 8-Pin DIP (300 Mil)	Small Outline SO8	Wide Body (400 Mil)	Hermetic ^a
Part Number	HCPL-4506	HCPL-J456	HCPL-0466	HCNW4506	HCPL-5300, HCPL-5301
IEC/EN/DIN EN 60747-5-5 Approval	V _{IORM} = 630 V _{peak} (Option 060)	V _{IORM} = 891 V _{peak}	V _{IORM} = 560 V _{peak} (Option 060)	V _{IORM} = 1414 V _{peak}	—

a. Technical data for these products are on separate Broadcom publications.

Ordering Information

HCPL-0466, HCPL-4506, and HCPL-J456 are UL recognized with 3750 V_{rms} for 1 minute per UL1577. HCNW4506 is UL recognized with 5000 V_{rms} for 1 minute per UL1577. HCPL-0466, HCPL-4506, HCPL-J456, and HCNW4506 are approved under CSA Component Acceptance Notice #5, File CA 88324.

Part Number	Option		Package	Surface Mount	Gull Wing	Tape and Reel	UL 5000 V _{rms} / 1 Minute Rating	IEC/EN/DIN EN 60747-5-5	Quantity
	RoHS Compliant	Non RoHS Compliant							
HCPL-4506	-000E	No Option	300 mil DIP-8						50 per tube
	-300E	#300		X	X				50 per tube
	-500E	#500		X	X	X			1000 per reel
	-020E	#020					X		50 per tube
	-320E	#320		X	X		X		50 per tube
	-520E	#520		X	X	X	X		1000 per reel
	-060E	#060						X	50 per tube
	-360E	#360		X	X			X	50 per tube
	-560E	#560		X	X	X		X	1000 per reel
HCPL-J456	-000E	No Option	300 mil DIP-8					X	50 per tube
	-300E	#300		X	X			X	50 per tube
	-500E	#500		X	X	X		X	1000 per reel
HCPL-0466	-000E	No Option	SO-8	X					100 per tube
	-500E	#500		X		X			1500 per reel
	-060E	#060		X				X	100 per tube
	-560E	#560		X		X		X	1500 per reel
HCNW4506	-000E	No Option	400 mil Wide Body DIP-8				X	X	42 per tube
	-300E	#300		X	X		X	X	42 per tube
	-500E	#500		X	X	X	X	X	750 per reel

To order, choose a part number from the Part Number column and combine with the desired option from the Option column to form an order entry.

Example 1: HCPL-3140-560E to order product of 300-mil DIP Gull Wing Surface-Mount package in Tape-and-Reel packaging with IEC/EN/DIN EN 60747-5-5 Safety Approval in RoHS compliant.

Example 2: HCPL-4506 to order product of 300-mil DIP package in Tube packaging and non RoHS compliant.

Option data sheets are available. Contact your Broadcom sales representative or authorized distributor for information.

NOTE: The notation #XXX is used for existing products, while (new) products launched since 15th July 2001 and RoHS compliant option will use -XXXE.

Package Outline Drawings

Figure 2: HCPL-4506 Outline Drawing

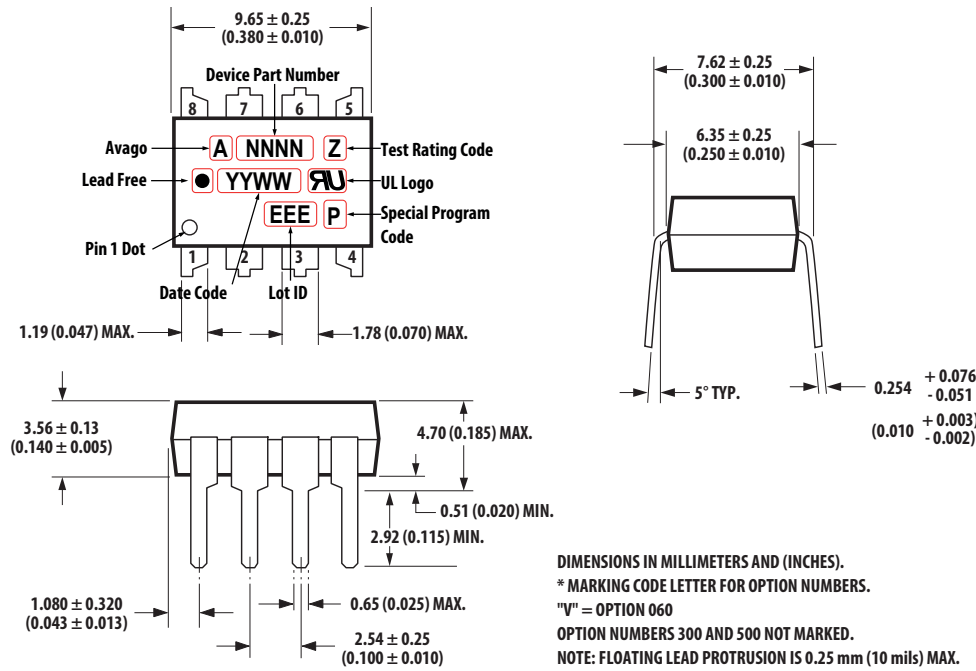

Figure 3: HCPL-4506 Gull Wing Surface-Mount Option 300 Outline Drawing

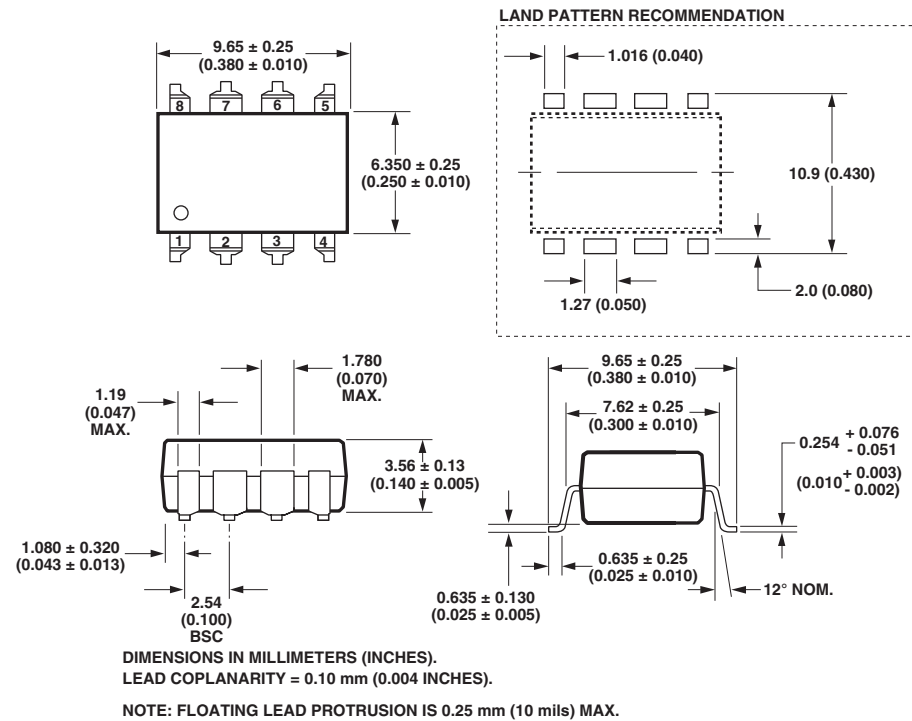

Figure 4: HCPL-J456 Outline Drawing

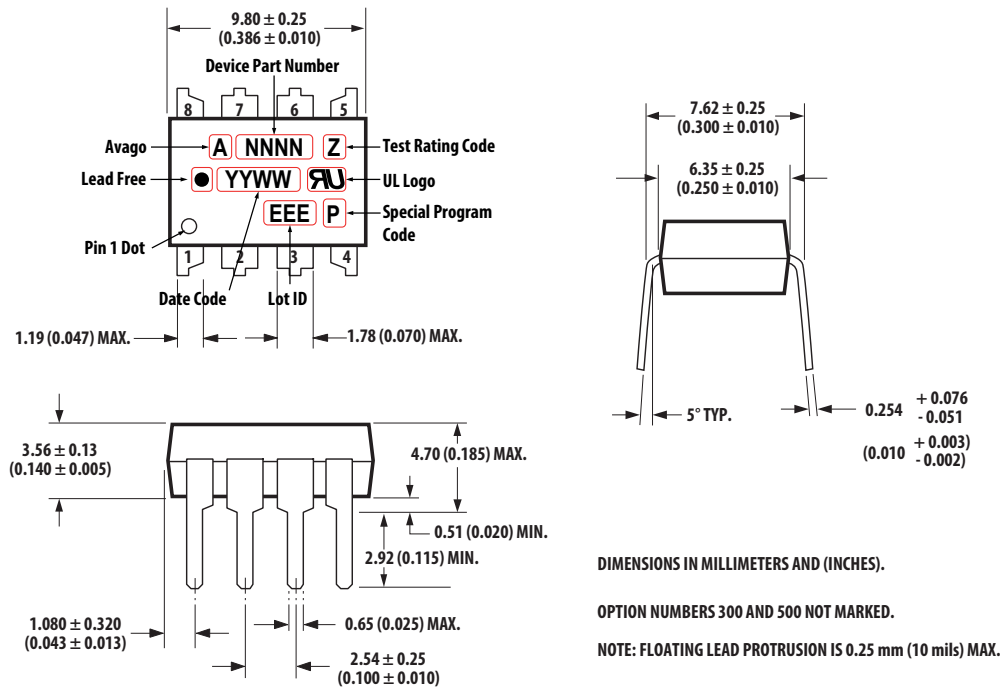

Figure 5: HCPL-J456 Gull Wing Surface-Mount Option 300 Outline Drawing

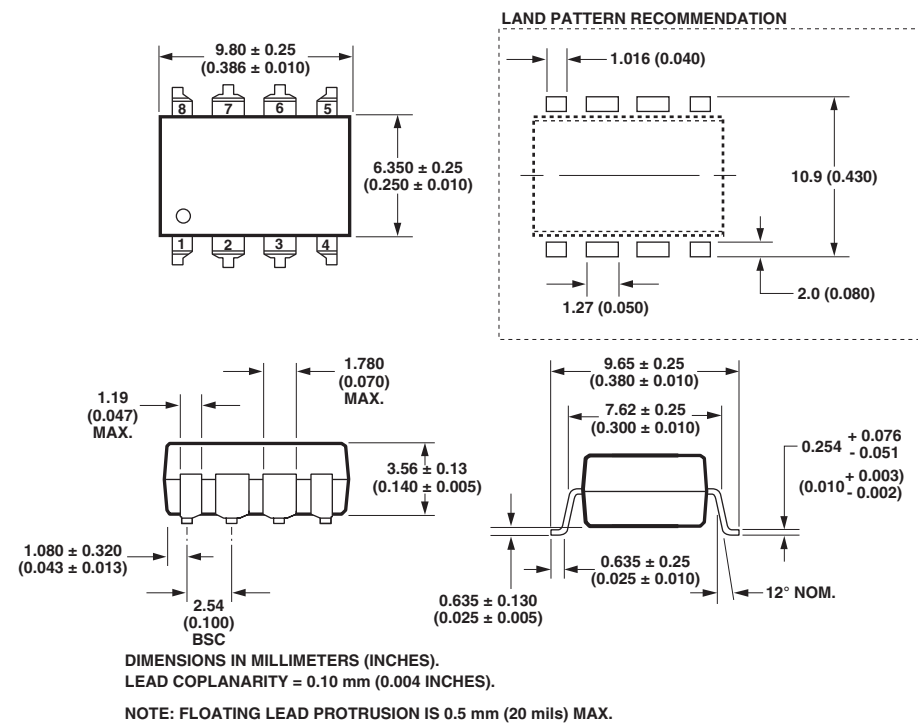
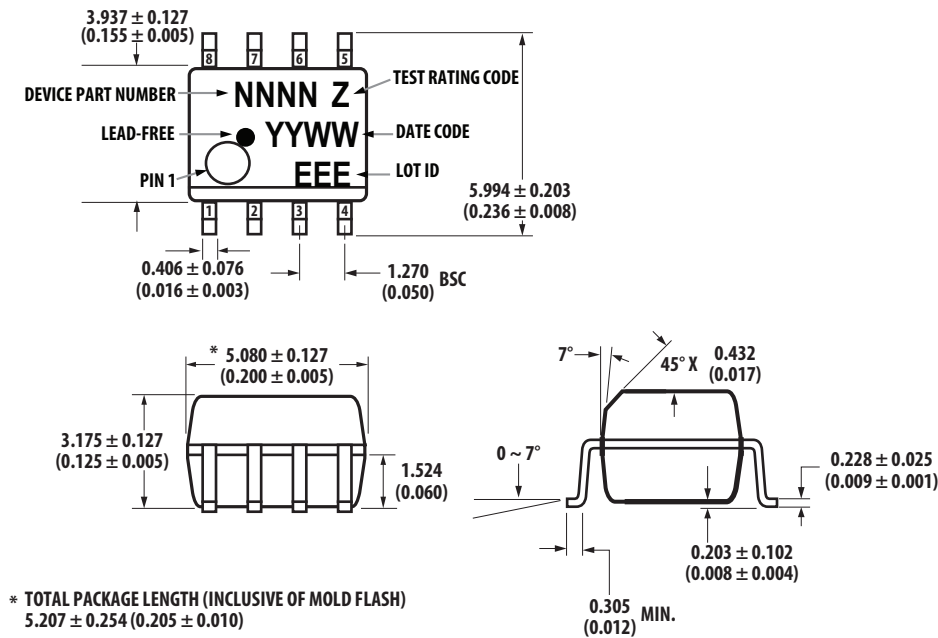

Figure 6: HCPL-0466 Outline Drawing (8-Pin Small Outline Package)



* TOTAL PACKAGE LENGTH (INCLUSIVE OF MOLD FLASH)
5.207 ± 0.254 (0.205 ± 0.010)

DIMENSIONS IN MILLIMETERS (INCHES).
LEAD COPLANARITY = 0.10 mm (0.004 INCHES) MAX.

NOTE: FLOATING LEAD PROTRUSION IS 0.15 mm (6 mils) MAX.

Figure 7: HCNW4506 Outline Drawing (8-Pin Wide Body Package)

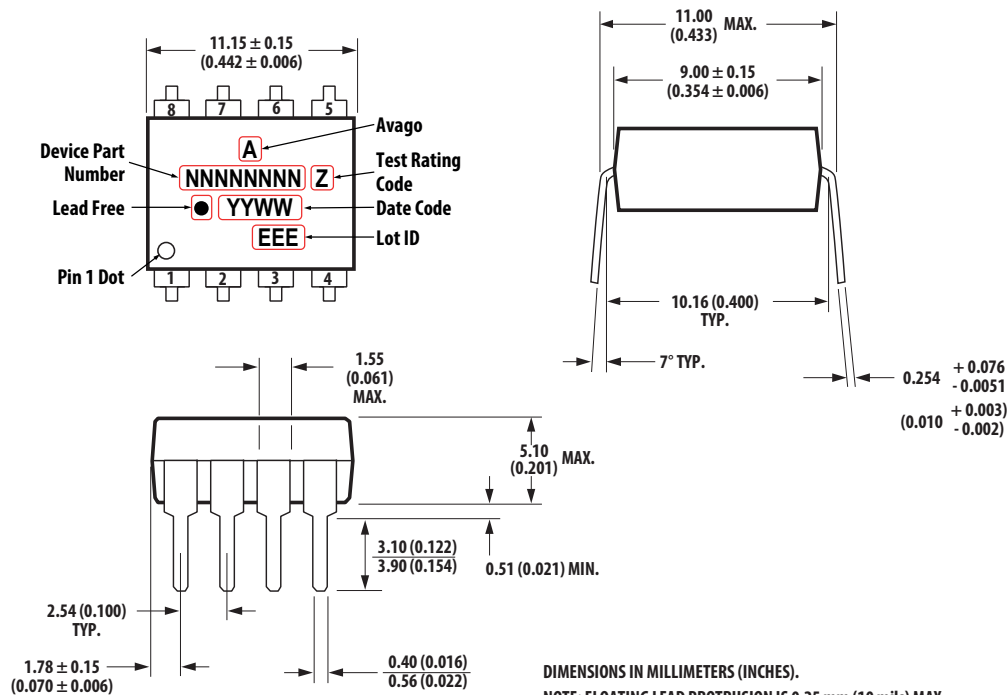

DIMENSIONS IN MILLIMETERS (INCHES).
NOTE: FLOATING LEAD PROTRUSION IS 0.25 mm (10 mils) MAX.

Figure 8: HCNW4506 Gull Wing Surface-Mount Option 300 Outline Drawing

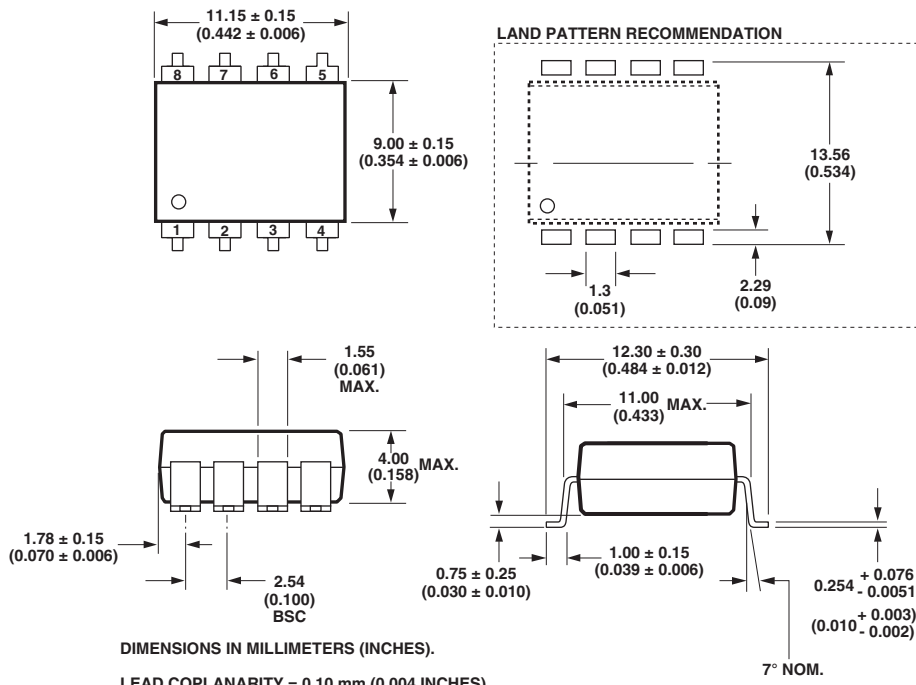

DIMENSIONS IN MILLIMETERS (INCHES).

LEAD COPLANARITY = 0.10 mm (0.004 INCHES).

NOTE: FLOATING LEAD PROTRUSION IS 0.25 mm (10 mils) MAX.

Figure 9: Solder Reflow Temperature Profile

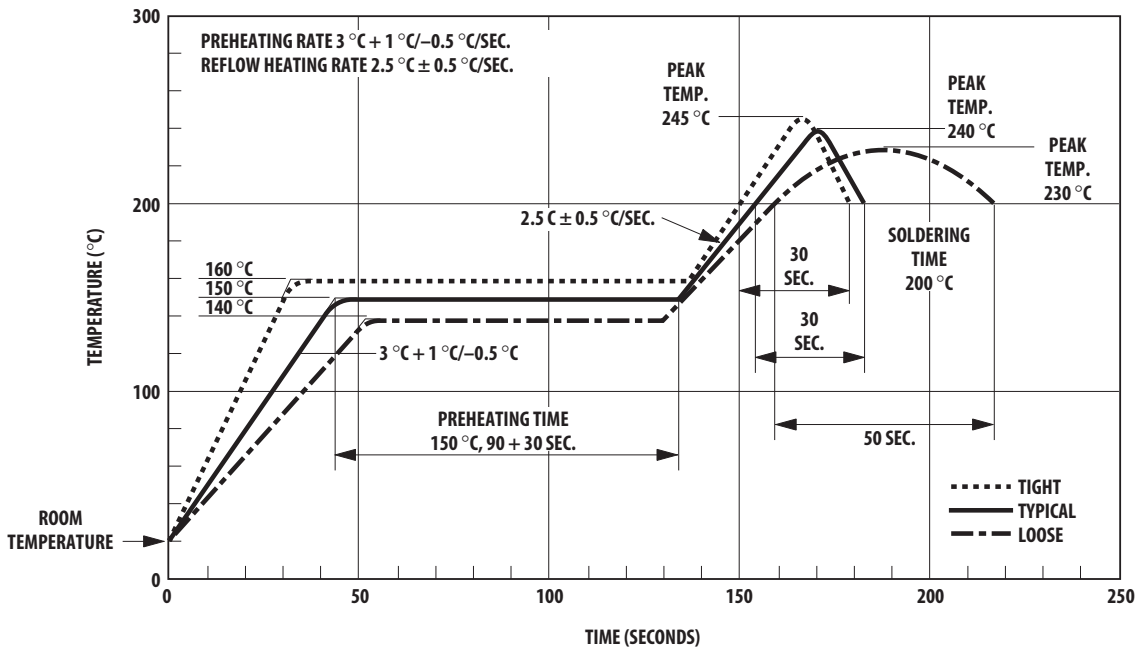

NOTE: NON-HALIDE FLUX SHOULD BE USED.

Figure 10: Recommended Pb-Free IR Profile

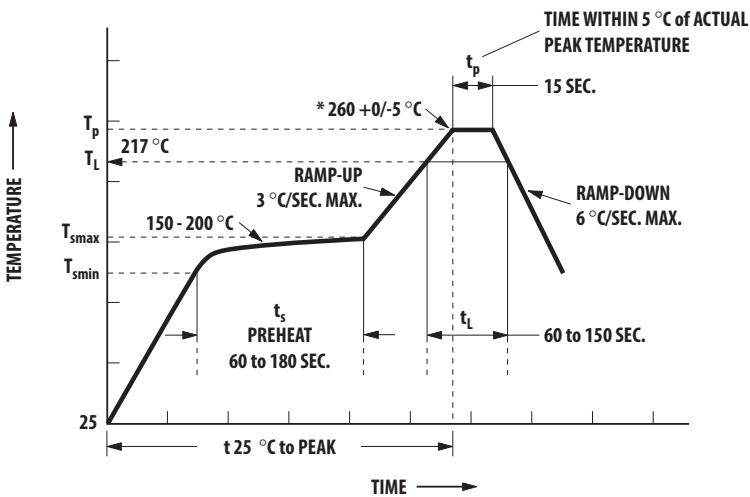

NOTES:

THE TIME FROM 25 °C to PEAK TEMPERATURE = 8 MINUTES MAX.

$T_{smax} = 200 °C$, $T_{smin} = 150 °C$

NOTE: NON-HALIDE FLUX SHOULD BE USED.

* RECOMMENDED PEAK TEMPERATURE FOR WIDEBODY 400mils PACKAGE IS 245 °C

Regulatory Information

The devices contained in this data sheet have been approved by the following organizations.

Agency/Standard		HCPL-4506	HCPL-J456	HCPL-0466	HCNW4506
Underwriters Laboratories (UL) Recognized under UL 1577, Component Recognized Program, Category FPQU2, File E55361	UL 1577	•	•	•	•
Canadian Standards Association (CSA) File CA88324	Component Acceptance Notice #5	•	•	•	•
Verband Deutscher Elektrotechniker (VDE)	DIN VDE 0884 (June 1992)	•	•		•
IEC/EN/DIN EN 60747-5-5 Approved under: IEC 60747-5-5:1997 + A1:2002 EN 60747-5-5:2001 + A1:2002 DIN EN 60747-5-5 (VDE 0884 Teil 2):2003-01		•	•	•	•

Insulation and Safety Related Specifications

Parameter	Symbol	Value				Unit	Conditions
		HCPL-4506	HCPL-J456	HCPL-0466	HCNW4506		
Minimum External Air Gap (External Clearance)	L(101)	7.1	7.4	4.9	9.6	mm	Measured from input terminals to output terminals, shortest distance through air.
Minimum External Tracking (External Creepage)	L(102)	7.4	8.0	4.8	10.0	mm	Measured from input terminals to output terminals, shortest distance path along body.
Minimum Internal Plastic Gap (Internal Clearance)		0.08	0.5	0.08	1.0	mm	Through insulation distance, conductor to conductor, usually the direct distance between the photoemitter and photodetector inside the optocoupler cavity.
Minimum Internal Tracking (Internal Creepage)		NA	NA	NA	4.0	mm	Measured from input terminals to output terminals, along internal cavity.
Tracking Resistance (Comparative Tracing Index)	CTI	≥175	≥175	≥175	≥200	V	DIN IEC 112/VDE 0303 Part 1.
Isolation Group		IIIa	IIIa	IIIa	IIIa		Material Group (DIN VDE 0110, 1/89, Table 1).

Broadcom data sheets report the creepage and clearance inherent to the optocoupler component itself. These dimensions are needed as a starting point for the equipment designer when determining the circuit insulation requirements. However, once mounted on a printed circuit board, minimum creepage and clearance requirements must be met as specified for individual equipment standards. For creepage, the shortest distance path along the surface of a printed circuit board between the solder fillets of the input and output leads must be considered. There are recommended techniques such as grooves and ribs that can be used on a printed circuit board to achieve desired creepage and clearances. Creepage and clearance distances will also change depending on factors such as pollution degree and insulation level.

IEC/EN/DIN EN 60747-5-5 Insulation Related Characteristics

Description	Symbol	HCPL-0466 Option 060	HCPL-4506 Option 060	HCPL-J456	HCNW4506	Unit
Installation Classification per DIN VDE 0110/1.89, Table 1						
For Rated Mains Voltage $\leq 150 V_{rms}$		I-IV	I-IV	I-IV	I-IV	
For Rated Mains Voltage $\leq 300 V_{rms}$		I-III	I-IV	I-IV	I-IV	
For Rated Mains Voltage $\leq 450 V_{rms}$			I-III	I-III	I-IV	
For Rated Mains Voltage $\leq 600 V_{rms}$				I-III	I-IV	
For Rated Mains Voltage $\leq 1000 V_{rms}$					I-III	
Climatic Classification		55/100/21	55/100/21	55/100/21	55/100/21	
Pollution Degree (DIN VDE 0110/1.89)		2	2	2	2	
Maximum Working Insulation Voltage	V_{IORM}	560	630	891	1414	V_{peak}
Input to Output Test Voltage, Method b ^a $V_{IORM} \times 1.875 = V_{PR}$, 100% Production Test with $t_m = 1$ second, Partial Discharge < 5 pC	V_{PR}	1050	1181	1670	2652	V_{peak}
Input to Output Test Voltage, Method a ^a $V_{IORM} \times 1.6 = V_{PR}$, Type and Sample Test, $t_m = 60$ seconds, Partial Discharge < 5 pC	V_{PR}	840	945	1336	2262	V_{peak}
Highest Allowable Overvoltage ^a (Transient Overvoltage, $t_{ini} = 60$ seconds)	V_{IOTM}	4000	6000	6000	8000	V_{peak}
Safety Limiting Values – maximum values allowed in the event of a failure, also see Thermal Derating curve.						
Case Temperature	T_S	150	175	175	150	°C
Input Current	$I_{S,INPUT}$	150	230	400	400	mA
Output Power	$P_{S,OUTPUT}$	600	600	600	700	mW
Insulation Resistance at T_S , $V_{IO} = 500V$	R_S	$\geq 10^9$	$\geq 10^9$	$\geq 10^9$	$\geq 10^9$	Ω

a. Refer to the optocoupler section of the Designer's Catalog, under regulatory information (IEC/EN/DIN EN 60747-5-5) for a detailed description of Method a and Method b partial discharge test profiles.

Notes:

These optocouplers are suitable for *safe electrical isolation* only within the safety limit data. Maintenance of the safety data shall be ensured by means of protective circuits.

Insulation Characteristics are per IEC/EN/DIN EN 60747-5-5.

Surface-mount classification is Class A in accordance with CECC 00802.

Absolute Maximum Ratings

Parameter	Symbol	Min.	Max.	Unit
Storage Temperature	T_S	-55	125	°C
Operating Temperature	T_A	-40	100	°C
Average Input Current ^a	$I_{F(AVG)}$	—	25	mA
Peak Input Current ^b (50% duty cycle, ≤1 ms pulse width)	$I_{F(PEAK)}$	—	50	mA
Peak Transient Input Current (<1 μs pulse width, 300 pps)	$I_{F(TRAN)}$	—	1.0	A
Reverse Input Voltage (Pin 3 to 2)	HCPL-4506, HCPL-0466	—	5	V
	HCPL-J456, HCNW4506	—	3	
Average Output Current (Pin 6)	$I_{O(AVG)}$	—	15	mA
Resistor Voltage (Pin 7)	V_7	-0.5	V_{CC}	V
Output Voltage (Pin 6 to 5)	V_O	-0.5	30	V
Supply Voltage (Pin 8 to 5)	V_{CC}	-0.5	30	V
Output Power Dissipation ^c	P_O	—	100	mW
Total Power Dissipation ^d	P_T	—	145	mW
Lead Solder Temperature (HCPL-4506, HCPL-J456)	260°C for 10 seconds, 1.6 mm below seating plane			
Lead Solder Temperature (HCNW4506)	260°C for 10 seconds (up to seating plane)			
Infrared and Vapor Phase Reflow Temperature (HCPL-0466 and Option 300)	See Package Outline Drawings section.			

a. Derate linearly above 90°C free-air temperature at a rate of 0.8 mA/°C.

b. Derate linearly above 90°C free-air temperature at a rate of 1.6 mA/°C.

c. Derate linearly above 90°C free-air temperature at a rate of 3.0 mW/°C.

d. Derate linearly above 90°C free-air temperature at a rate of 4.2 mW/°C.

Recommended Operating Conditions

Parameter	Symbol	Min.	Max.	Unit
Power Supply Voltage	V_{CC}	4.5	30	V
Output Voltage	V_O	0	30	V
Input Current (ON)	$I_{F(ON)}$	10	20	mA
Input Voltage (OFF)	$V_{F(OFF)}$ ^a	-5	0.8	V
Operating Temperature	T_A	-40	100	°C

a. Recommended $V_{F(OFF)} = -3V$ to 0.8V for HCPL-J456, HCNW4506.

Electrical Specifications (DC)

Over recommended operating conditions unless otherwise specified.

$T_A = -40^{\circ}\text{C}$ to $+100^{\circ}\text{C}$, $V_{CC} = +4.5\text{V}$ to 30V , $I_{F(\text{on})} = 10\text{ mA}$ to 20 mA , $V_{F(\text{off})} = -5\text{V}$ to 0.8V . (For HCPL-J456 and HCNW4506, $V_{F(\text{off})} = -3\text{V}$ to 0.8V).

Parameter	Symbol	Device	Min.	Typ. ^a	Max.	Unit	Test Conditions	Fig.	Note
Current Transfer Ratio	CTR		44	90	—	%	$I_F = 10\text{ mA}$, $V_O = 0.6\text{V}$		b
Low Level Output Current	I_{OL}		4.4	9.0	—	mA	$I_F = 10\text{ mA}$, $V_O = 0.6\text{V}$	11, 12	
Low Level Output Voltage	V_{OL}		—	0.3	0.6	V	$I_O = 2.4\text{ mA}$		
Input Threshold Current	I_{TH}	HCPL-4506 HCPL-0466 HCNW4506	—	1.5	5	mA	$V_O = 0.8\text{V}$, $I_O = 0.75\text{ mA}$	11	c
		HCPL-J456	—	0.6					
High Level Output Current	I_{OH}		—	5	50	μA	$V_F = 0.8\text{V}$	13	
High Level Supply Current	I_{CCH}		—	0.6	1.3	mA	$V_F = 0.8\text{V}$, $V_O = \text{Open}$		c
Low Level Supply Current	I_{CCL}		—	0.6	1.3	mA	$I_F = 10\text{ mA}$, $V_O = \text{Open}$		c
Input Forward Voltage	V_F	HCPL-4506 HCPL-0466	—	1.5	1.8	V	$I_F = 10\text{ mA}$	14	
		HCPL-J456	1.2	1.6	1.95				
		HCNW4506	—	1.6	1.85				
Temperature Coefficient of Forward Voltage	$\Delta V_F/\Delta T_A$	HCPL-4506 HCPL-0466	—	-1.6		$\text{mV}/^{\circ}\text{C}$	$I_F = 10\text{ mA}$		
		HCPL-J456 HCNW4506	—	-1.3					
Input Reverse Breakdown Voltage	BV_R	HCPL-4506 HCPL-0466	5	—	—	V	$I_R = 10\text{ }\mu\text{A}$		
		HCPL-J456 HCNW4506	3	—	—				
Input Capacitance	C_{IN}	HCPL-4506 HCPL-0466	—	60	—	pF	$f = 1\text{ MHz}$, $V_F = 0\text{V}$		
		HCPL-J456 HCNW4506	—	72	—				
Internal Pull-up Resistor	R_L		14	20	25	$\text{k}\Omega$	$T_A = 25^{\circ}\text{C}$		d, e
Internal Pull-up Resistor Temperature Coefficient	$\Delta R_L/\Delta T_A$		—	0.014	—	$\text{k}\Omega/^{\circ}\text{C}$			

a. All typical values at 25°C , $V_{CC} = 15\text{V}$.

b. Current Transfer Ratio in percent is defined as the ratio of output collector current (I_O) to the forward LED input current (I_F) times 100.

c. Use of a $0.1\text{-}\mu\text{F}$ bypass capacitor connected between pins 5 and 8 can improve performance by filtering power supply line noise.

d. The internal $20\text{-k}\Omega$ resistor can be used by shorting pins 6 and 7 together.

e. Due to tolerance of the internal resistor, and since propagation delay is dependent on the load resistor value, performance can be improved by using an external $20\text{-k}\Omega$ 1% load resistor. For more information on how propagation delay varies with load resistance, see [Figure 18](#).

Switching Specifications ($R_L = 20\text{ k}\Omega$ External)

Over recommended operating conditions unless otherwise specified.

$T_A = -40^\circ\text{C}$ to $+100^\circ\text{C}$, $V_{CC} = +4.5\text{V}$ to 30V , $I_{F(\text{on})} = 10\text{ mA}$ to 20 mA , $V_{F(\text{off})} = -5\text{V}$ to 0.8V . (For HCPL-J456 and HCNW4506, $V_{F(\text{off})} = -3\text{V}$ to 0.8V).

Parameter	Symbol	Min.	Typ. ^a	Max.	Unit	Test Conditions		Fig.	Note
Propagation Delay Time to Logic, HCPL-J456 Low at Output	t_{PHL}	30	200	400	ns	$C_L = 100\text{ pF}$	$I_{F(\text{on})} = 10\text{ mA}$, $V_{F(\text{off})} = 0.8\text{V}$, $V_{CC} = 15.0\text{V}$, $V_{\text{THLH}} = 2.0\text{V}$, $V_{\text{THHL}} = 1.5\text{V}$	16, 18, 20, 21, 22, 23	b, c, d
		—	100	—					
Propagation Delay Time to High Output Level	t_{PLH}	270	400	550	ns	$C_L = 100\text{ pF}$ $C_L = 10\text{ pF}$	$V_{\text{THLH}} = 2.0\text{V}$, $V_{\text{THHL}} = 1.5\text{V}$		
		—	130	—					
Pulse Width Distortion	PWD	—	200	450	ns	$C_L = 100\text{ pF}$			e
Propagation Delay Difference Between Any 2 Parts	$t_{\text{PLH}} - t_{\text{PHL}}$	-150	200	450	ns				f
Output High Level Common Mode Transient Immunity	$ CM_H $	15	30	—	kV/ μs	$I_F = 0\text{ mA}$, $V_O > 3.0\text{V}$	$V_{CC} = 15.0\text{V}$, $C_L = 100\text{ pF}$	17	g
Output Low Level Common Mode Transient Immunity	$ CM_L $	15	30	—	kV/ μs	$I_F = 10\text{ mA}$, $V_O < 1.0\text{V}$	$V_{CM} = 1500\text{ V}_{\text{p-p}}$, $T_A = 25^\circ\text{C}$		h

- a. All typical values at 25°C , $V_{CC} = 15\text{V}$.
- b. Pulse: $f = 20\text{ kHz}$, Duty Cycle = 10%.
- c. The $R_L = 20\text{ k}\Omega$, $C_L = 100\text{ pF}$ load represents a typical IPM (Intelligent Power Module) load.
- d. Use of a $0.1\text{-}\mu\text{F}$ bypass capacitor connected between pins 5 and 8 can improve performance by filtering power supply line noise.
- e. Pulse Width Distortion (PWD) is defined as $|t_{\text{PHL}} - t_{\text{PLH}}|$ for any given device.
- f. The difference between t_{PLH} and t_{PHL} between any two devices under the same test condition. (See IPM Dead Time and Propagation Delay Specifications section.)
- g. Common mode transient immunity in a logic high level is the maximum tolerable dV_{CM}/dt of the common mode pulse, V_{CM} , to ensure that the output will remain in a logic high state (that is, $V_O > 3.0\text{V}$).
- h. Common mode transient immunity in a logic low level is the maximum tolerable dV_{CM}/dt of the common mode pulse, V_{CM} , to ensure that the output will remain in a logic low state (that is, $V_O < 1.0\text{V}$).

Switching Specifications (R_L = Internal Pull-up)

Over recommended operating conditions unless otherwise specified.

T_A = -40°C to +100°C, V_{CC} = +4.5V to 30V, I_{F(on)} = 10 mA to 20 mA, V_{F(off)} = -5V to 0.8V (V_{F(off)} = -3V to 0.8V). (For HCPL-J456 and HCNW4506, V_{F(off)} = -3V to 0.8V).

Parameter	Symbol	Min.	Typ ^a	Max.	Unit	Test Conditions	Fig.	Note
Propagation Delay Time to Logic, HCPL-J456 Low at Output	T _{PHL}	20	200	400 485	ns	I _{F(on)} = 10 mA, V _{F(off)} = 0.8V, V _{CC} = 15.0V, C _L = 100 pF, V _{THLH} = 2.0V, V _{THHL} = 1.5V	16, 19	b, c, d, e, f
Propagation Delay Time to High Output Level	t _{PLH}	220	450	650	ns			g
Pulse Width Distortion	PWD	—	250	500	ns			h
Propagation Delay Difference Between Any 2 Parts	t _{PLH} - t _{PHL}	-150	250	500	ns			h
Output High Level Common Mode Transient Immunity	CM _H	—	30	—	kV/μs	I _F = 0 mA, V _O > 3.0V V _{CC} = 15.0V, C _L = 100 pF,	17	i
Output Low Level Common Mode Transient Immunity	CM _L	—	30	—	kV/μs	I _F = 16 mA, V _O < 1.0V V _{CM} = 1500 Vp-p, T _A = 25°C		j
Power Supply Rejection	PSR	—	1.0	—	V _{p-p}	Square Wave, t _{RISE} , t _{FALL} > 5 ns, no bypass capacitors		f

- a. All typical values at 25°C, V_{CC} = 15V
- b. Pulse: f = 20 kHz, Duty Cycle = 10%.
- c. The internal 20-kΩ resistor can be used by shorting pins 6 and 7 together.
- d. Due to tolerance of the internal resistor, and since propagation delay is dependent on the load resistor value, performance can be improved by using an external 20-kΩ 1% load resistor. For more information on how propagation delay varies with load resistance, see [Figure 18](#).
- e. The R_L = 20 kΩ, C_L = 100 pF load represents a typical IPM (Intelligent Power Module) load.
- f. Use of a 0.1-μF bypass capacitor connected between pins 5 and 8 can improve performance by filtering power supply line noise.
- g. Pulse Width Distortion (PWD) is defined as |t_{PHL} - t_{PLH}| for any given device.
- h. The difference between t_{PLH} and t_{PHL} between any two devices under the same test condition. (See IPM Dead Time and Propagation Delay Specifications section.)
- i. Common mode transient immunity in a logic high level is the maximum tolerable dV_{CM}/dt of the common mode pulse, V_{CM}, to ensure that the output will remain in a logic high state (that is, V_O > 3.0V).
- j. Common mode transient immunity in a logic low level is the maximum tolerable dV_{CM}/dt of the common mode pulse, V_{CM}, to ensure that the output will remain in a logic low state (that is, V_O < 1.0V).

Package Characteristics

Over recommended temperature ($T_A = -40^{\circ}\text{C}$ to 100°C) unless otherwise specified.

Parameter	Sym.	Device	Min.	Typ. ^a	Max.	Unit	Test Conditions	Fig.	Note
Input-Output Momentary Withstand Voltage ^b	V_{ISO}	HCPL-4506 HCPL-0466	3750	—	—	V_{rms}	RH < 50% t = 1 min. $T_A = 25^{\circ}\text{C}$		c, d, e
		HCPL-J456	3750	—	—				c, f, e
		HCPL-4506, Option 020	5000	—	—				c, g, h
		HCNW4506	5000	—	—				c, g, e
Resistance (Input-Output)	R_{I-O}	HCPL-4506 HCPL-J456 HCPL-0466	—	10^{12}	—	Ω	$V_{I-O} = 500\text{ Vdc}$		c
		HCNW4506	10^{12}	10^{13}	—				
Capacitance (Input-Output)	C_{I-O}	HCPL-4506 HCPL-0466	—	0.6	—	pF	f = 1 MHz		c
		HCPL-J456	—	0.8	—				
		HCNW4506	—	0.5	—				

a. All typical values at 25°C , $V_{CC} = 15\text{V}$.

b. The Input-Output Momentary Withstand Voltage is a dielectric voltage rating that should not be interpreted as an input-output continuous voltage rating. For the continuous voltage rating, refer to the IEC/EN/DIN EN 60747-5-5 Insulation Related Characteristics Table (if applicable), your equipment level safety specification, or Broadcom Application Note 1074, *Optocoupler Input-Output Endurance Voltage*, (publication number 5963-2203E).

c. Device considered a two-terminal device: pins 1, 2, 3, and 4 shorted together, and pins 5, 6, 7, and 8 shorted together.

d. In accordance with UL 1577, each optocoupler is proof-tested by applying an insulation test voltage $\geq 4500 V_{rms}$ for 1 second (leakage detection current limit, $I_{I-O} \leq 5 \mu\text{A}$).

e. This test is performed before the 100% Production test shown in the IEC/EN/DIN EN 60747-5-5 Insulation Related Characteristics Table, if applicable.

f. In accordance with UL 1577, each optocoupler is proof tested by applying an insulation test voltage $\geq 4500 V_{rms}$ for 1 second (leakage detection current limit, $I_{I-O} \leq 5 \mu\text{A}$).

g. In accordance with UL 1577, each optocoupler is proof tested by applying an insulation test voltage $\geq 6000 V_{rms}$ for 1 second (leakage detection current limit, $I_{I-O} \leq 5 \mu\text{A}$).

h. See Option 020 data sheet for more information.

Figure 11: Typical Transfer Characteristics

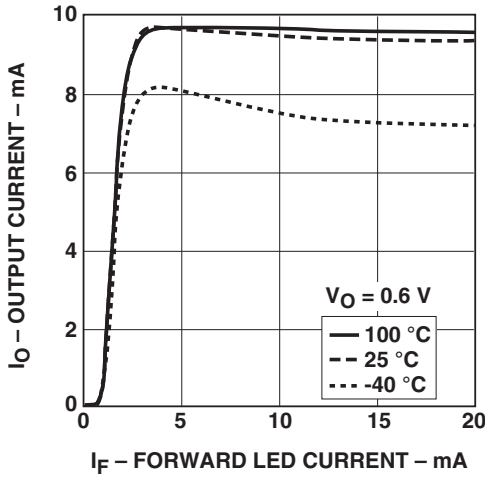

Figure 12: Normalized Output Current vs. Temperature

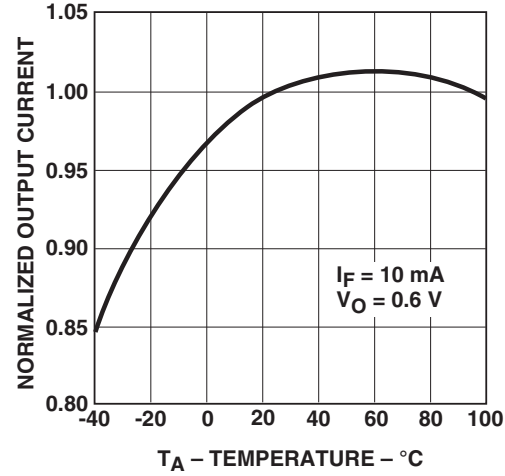

Figure 13: High Level Output Current vs. Temperature

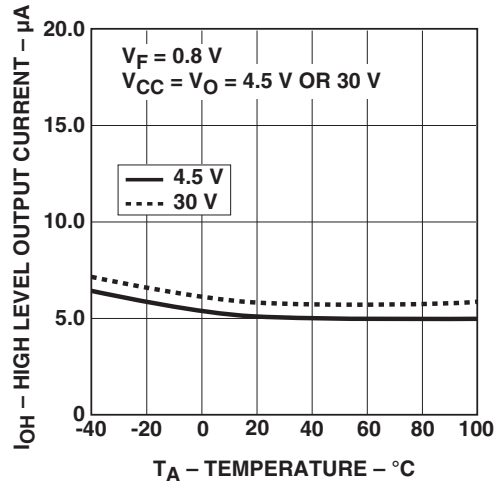

Figure 14: HCPL-4506 and HCPL-0466 Input Current vs. Forward Voltage

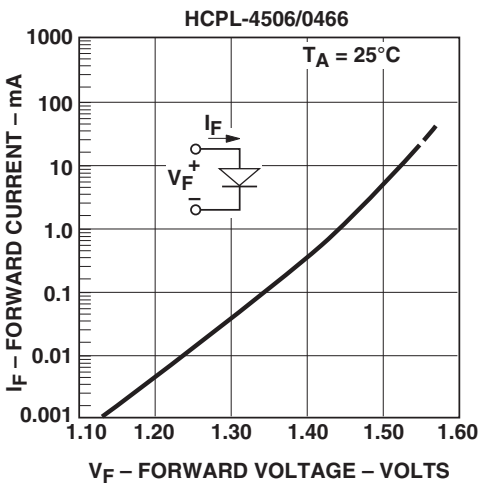

Figure 15: HCPL-J456 and HCNW4506 Input Current vs. Forward Voltage

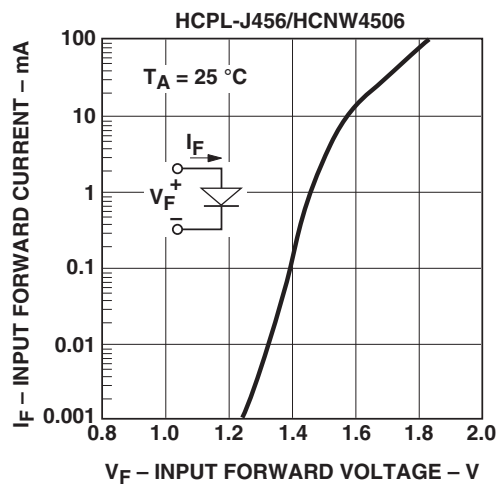

Figure 16: Propagation Delay Test Circuit

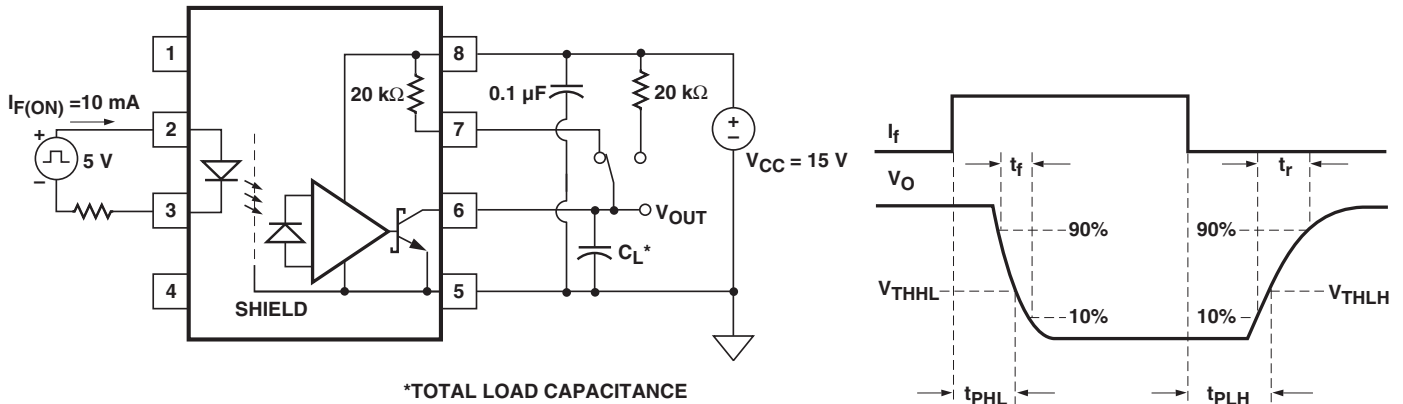

Figure 17: CMR Test Circuit, Typical CMR Waveform

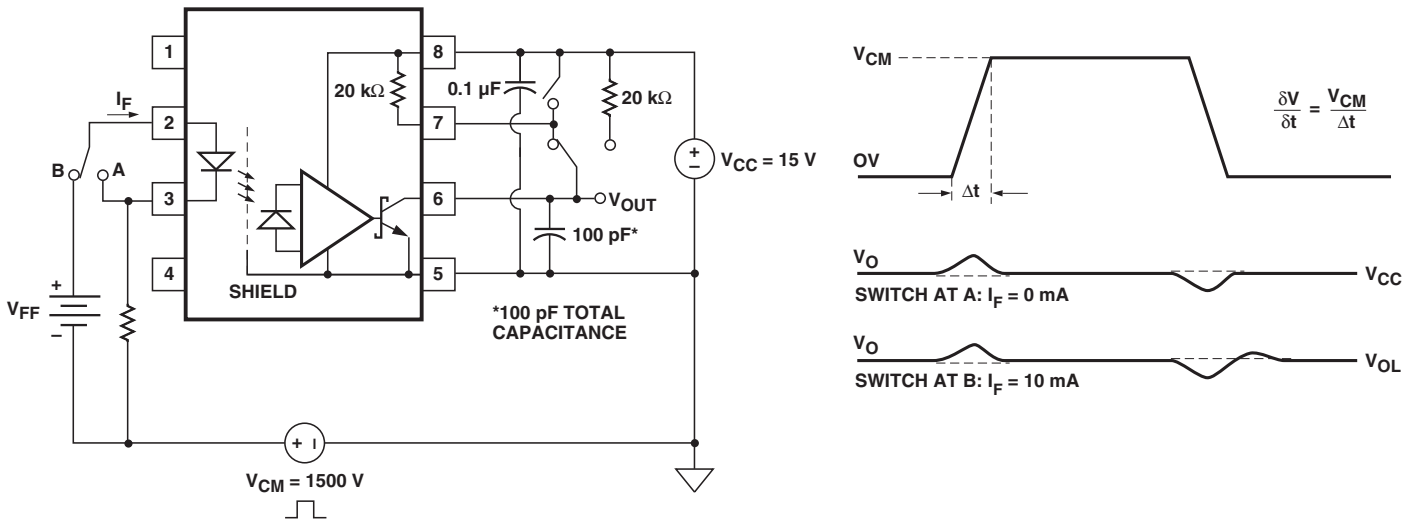

Figure 18: Propagation Delay with External 20 kΩ RL vs. Temperature

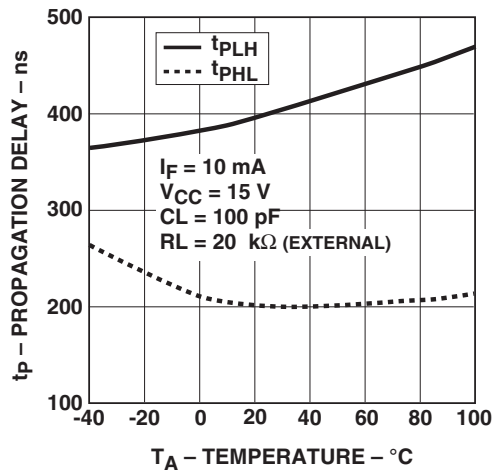

Figure 19: Propagation Delay with Internal 20 kΩ RL vs. Temperature

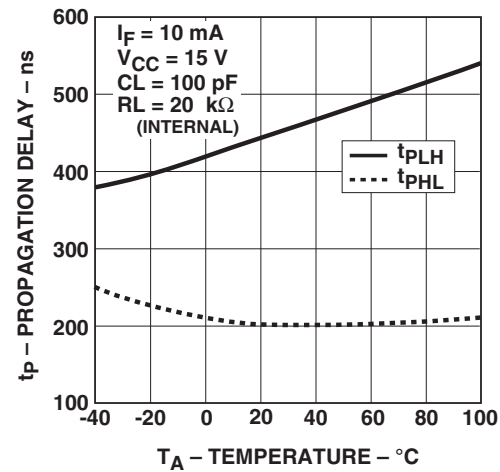

Figure 20: Propagation Delay vs. Load Resistance

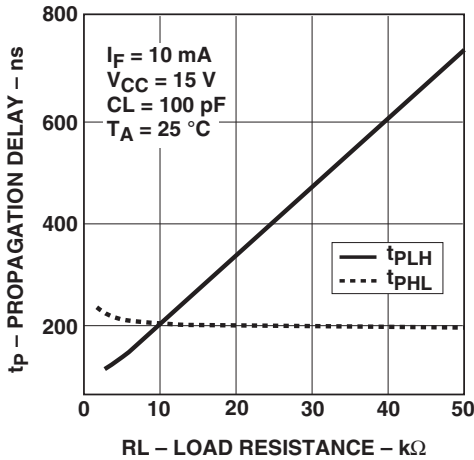

Figure 21: Propagation Delay vs. Load Capacitance

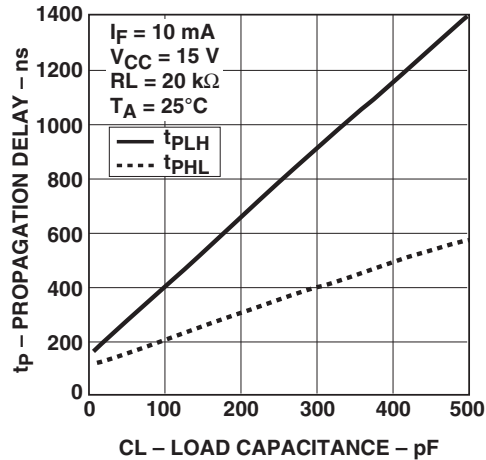

Figure 22: Propagation Delay vs. Supply Voltage

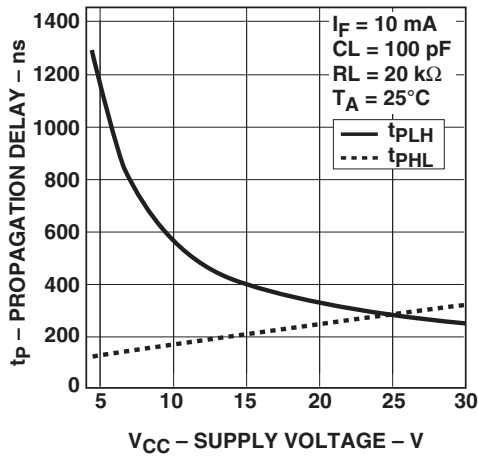

Figure 23: Propagation Delay vs. Input Current

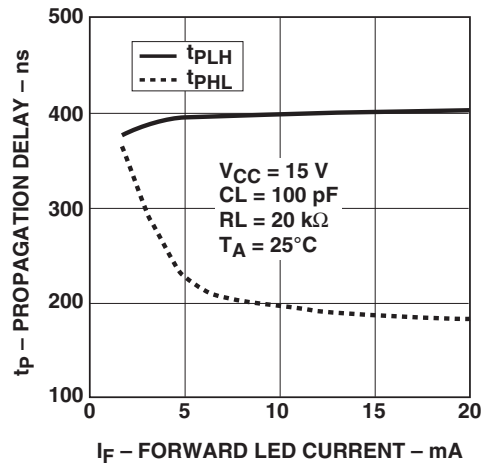

Figure 24: Thermal Derating Curve, HCPL-4506 Option 060/ HCPL-J456

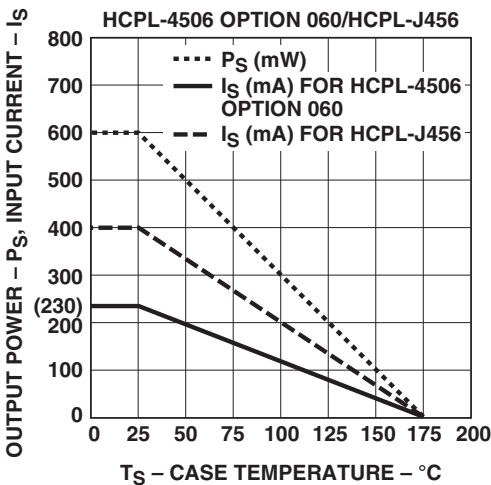
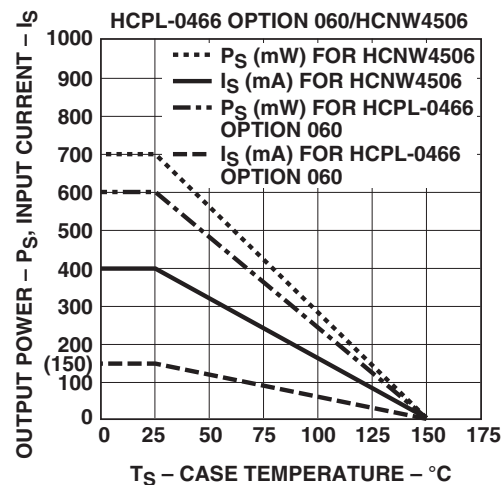

Figure 25: Thermal Derating Curve, HCPL-4506 Option 060/ HCNW4506



Note: Dependence of safety limiting value with case temperature per IEC/EN/DIN EN 60747-5-5).

Note: Dependence of safety limiting value with case temperature per IEC/EN/DIN EN 60747-5-5).

Figure 26: Recommended LED Drive Circuit

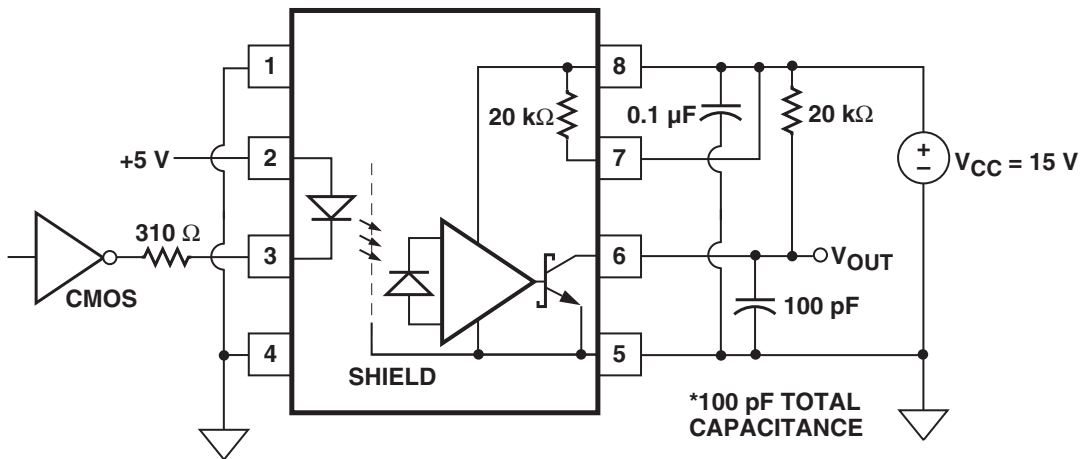

Figure 27: Optocoupler Input-to-Output Capacitance Model for Unshielded Optocouplers

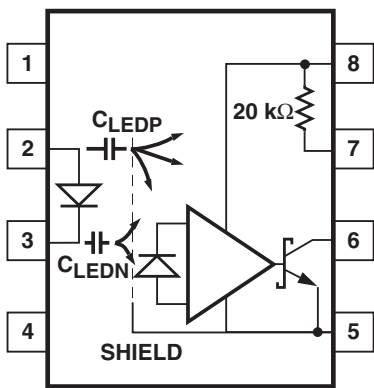

Figure 28: Optocoupler Input-to-Output Capacitance Model for Shielded Optocouplers

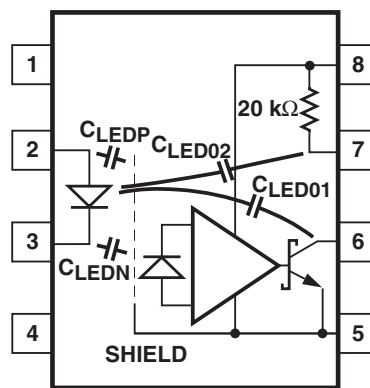

Figure 29: LED Drive Circuit with Resistor Connected to LED Anode (Not Recommended)

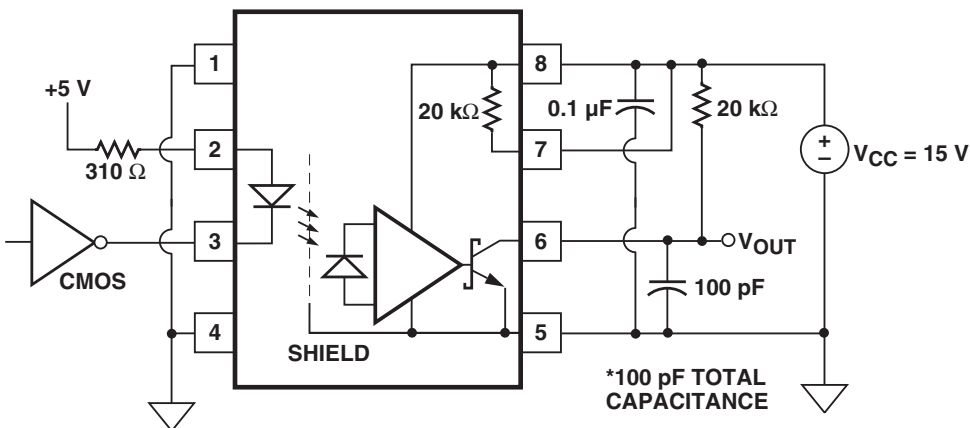

Figure 30: AC Equivalent Circuit for Figure 29 during Common Mode Transients

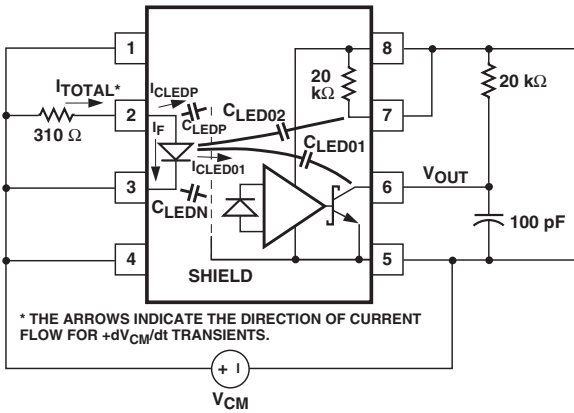

Figure 31: AC Equivalent Circuit for Figure 26 during Common Mode Transients

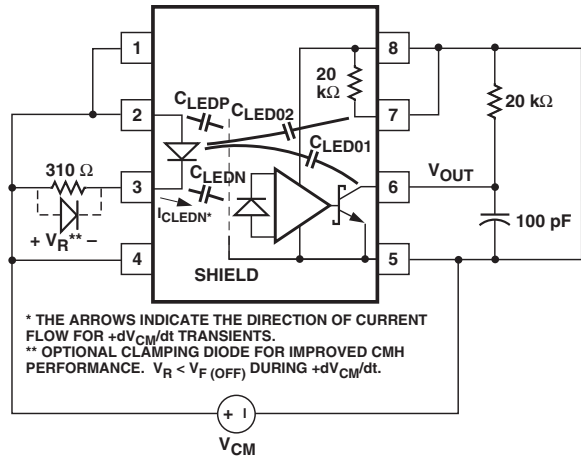

Figure 32: AC Equivalent Circuit for Figure 33 during Common Mode Transients

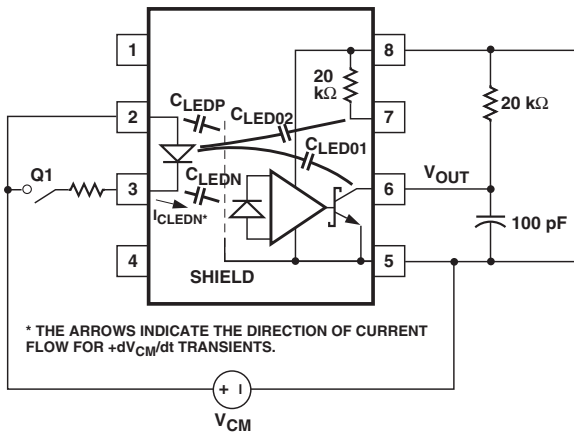

Figure 33: Not Recommended Open Collector LED Drive Circuit

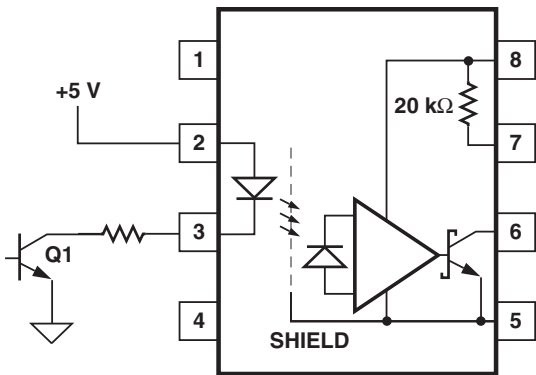

Figure 34: Recommended LED Drive Circuit for Ultra High CMR

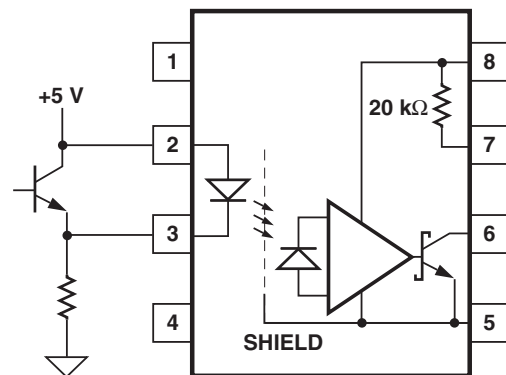

Figure 35: Typical Application Circuit

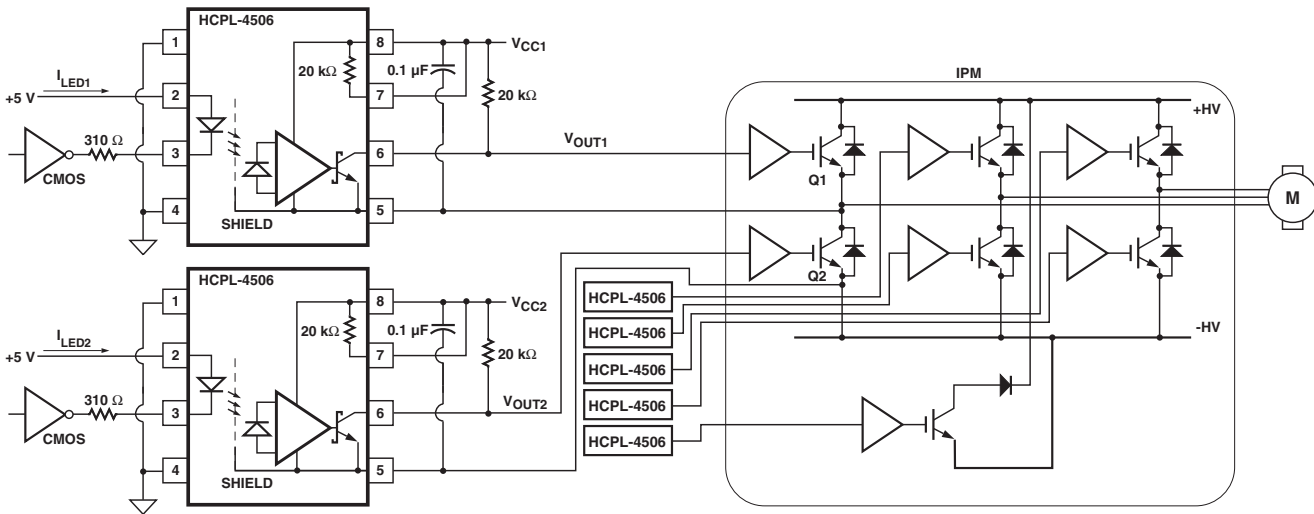
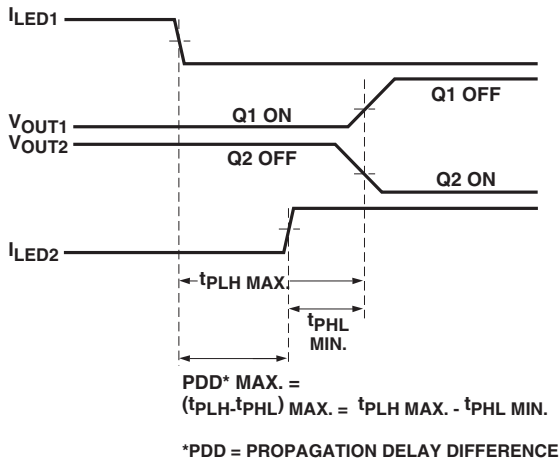
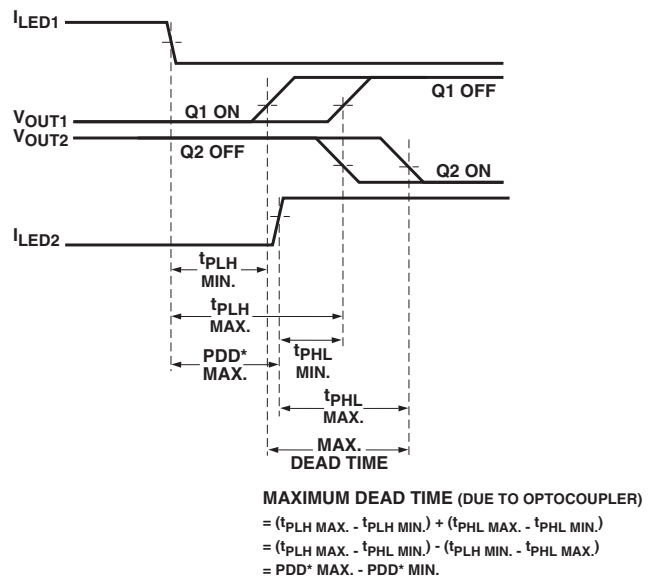

Figure 36: Minimum LED Skew for Zero Dead Time



NOTE: THE PROPAGATION DELAYS USED TO CALCULATE PDD ARE TAKEN AT EQUAL TEMPERATURES.

Figure 37: Waveforms for Dead Time Calculation



*PDD = PROPAGATION DELAY DIFFERENCE
NOTE: THE PROPAGATION DELAYS USED TO CALCULATE THE MAXIMUM DEAD TIME ARE TAKEN AT EQUAL TEMPERATURES.

Applications Information

LED Drive Circuit Considerations for Ultra High CMR Performance

Without a detector shield, the dominant cause of optocoupler CMR failure is capacitive coupling from the input side of the optocoupler, through the package, to the detector IC as shown in Figure 27. The HCPL-4506 series improves CMR performance by using a detector IC with an optically transparent Faraday shield, which diverts the capacitively coupled current away from the sensitive IC circuitry. However, this shield does not eliminate the capacitive coupling between the LED and the optocoupler output pins and output ground as shown in Figure 28. This capacitive coupling causes perturbations in the LED current during common mode transients and becomes the major source of CMR failures for a shielded optocoupler. The main design objective of a high CMR LED drive circuit becomes keeping the LED in the proper state (on or off) during common mode transients. For example, the recommended application circuit (Figure 26), can achieve 15-kV/ μ s CMR while minimizing component complexity. Use a CMOS gate as shown in Figure 26 to keep the LED off when the gate is in the high state.

Another cause of CMR failure for a shielded optocoupler is direct coupling to the optocoupler output pins through C_{LEDO1} and C_{LEDO2} in Figure 28. Many factors influence the effect and magnitude of the direct coupling including the use of an internal or external output pull-up resistor, the position of the LED current setting resistor, the connection of the unused input package pins, and the value of the capacitor at the optocoupler output (C_L).

Techniques to keep the LED in the proper state and minimize the effect of the direct coupling are discussed in the next two sections.

CMR with the LED On (CMR_L)

A high CMR LED drive circuit must keep the LED on during common mode transients. This is achieved by overdriving the LED current beyond the input threshold so that it is not pulled below the threshold during a transient. The recommended minimum LED current of 10 mA provides adequate margin over the maximum I_{TH} of 5.0 mA (see Figure 11) to achieve 15-kV/ μ s CMR. Capacitive coupling is higher when the internal load resistor is used (due to C_{LEDO2}) and an $I_F = 16$ mA is required to obtain 10-kV/ μ s CMR.

The placement of the LED current setting resistor affects the ability of the drive circuit to keep the LED on during transients and interacts with the direct coupling to the optocoupler output. For example, the LED resistor in Figure 29 is connected to the anode. Figure 30 shows the AC equivalent circuit for Figure 29 during common mode transients. During a $+dV_{CM}/dt$ in Figure 30, the current available at the LED anode (I_{total}) is limited by the series resistor. The LED current (I_F) is reduced from its DC value by an amount equal to the current that flows through C_{LEDP} and C_{LEDO1} . The situation is made worse because the current through C_{LEDO1} has the effect of trying to pull the output high (toward a CMR failure) at the same time the LED current is being reduced. For this reason, the recommended LED drive circuit (Figure 26) places the current setting resistor in series with the LED cathode. Figure 31 is the AC equivalent circuit for Figure 26 during common mode transients. In this case, the LED current is not reduced during a $+dV_{cm}/dt$ transient because the current flowing through the package capacitance is supplied by the power supply. During a $-dV_{CM}/dt$ transient, however, the LED current is reduced by the amount of current flowing through C_{LEDN} . But, better CMR performance is achieved since the current flowing in C_{LEDO1} during a negative transient acts to keep the output low.

Coupling to the LED and output pins is also affected by the connection of pins 1 and 4. If CMR is limited by perturbations in the LED on current, as it is for the recommended drive circuit (Figure 26), pins 1 and 4 should be connected to the input circuit common. However, if CMR performance is limited by direct coupling to the output when the LED is off, pins 1 and 4 should be left unconnected.

CMR with the LED Off (CMR_H)

A high CMR LED drive circuit must keep the LED off ($V_F \leq V_{F(OFF)}$) during common mode transients. For example, during a $+dV_{CM}/dt$ transient in Figure 31, the current flowing through C_{LEDN} is supplied by the parallel combination of the LED and series resistor. As long as the voltage developed across the resistor is less than $V_{F(OFF)}$, the LED will remain off and no common mode failure will occur. Even if the LED momentarily turns on, the 100-pF capacitor from pins 6 to 5 will keep the output from dipping below the threshold. The recommended LED drive circuit (Figure 26) provides about 10V of margin between the lowest optocoupler output voltage and a 3V IPM threshold during a 15-kV/ μ s transient with $V_{CM} = 1500V$.

Additional margin can be obtained by adding a diode in parallel with the resistor, as shown by the dashed line connection in [Figure 31](#), to clamp the voltage across the LED below $V_{F(OFF)}$.

Since the open collector drive circuit, shown in [Figure 33](#), cannot keep the LED off during a $+dV_{CM}/dt$ transient, it is not desirable for applications requiring ultra high CMR_H performance. [Figure 32](#) is the AC equivalent circuit for [Figure 33](#) during common mode transients. Essentially all the current flowing through C_{LEDN} during a $+dV_{CM}/dt$ transient must be supplied by the LED. CMR_H failures can occur at dV/dt rates where the current through the LED and C_{LEDN} exceeds the input threshold. [Figure 34](#) is an alternative drive circuit that does achieve ultra high CMR performance by shunting the LED in the off state.

IPM Dead Time and Propagation Delay Specifications

The HCPL-4506 series includes a Propagation Delay Difference specification intended to help designers minimize *dead time* in their power inverter designs. Dead time is the time period during which both the high and low side power transistors (Q1 and Q2 in [Figure 35](#)) are off. Any overlap in Q1 and Q2 conduction will result in large currents flowing through the power devices between the high and low voltage motor rails.

To minimize dead time, the designer must consider the propagation delay characteristics of the optocoupler as well as the characteristics of the IPM IGBT gate drive circuit. Considering only the delay characteristics of the optocoupler (the characteristics of the IPM IGBT gate drive circuit can be analyzed in the same way), it is important to know the minimum and maximum turn-on (t_{PHL}) and turn-off (t_{PLH}) propagation delay specifications, preferably over the desired operating temperature range.

The limiting case of zero dead time occurs when the input to Q1 turns off at the same time that the input to Q2 turns on. This case determines the minimum delay between LED1 turn-off and LED2 turn-on, which is related to the worst-case optocoupler propagation delay waveforms, as shown in [Figure 36](#). A minimum dead time of zero is achieved in [Figure 36](#) when the signal to turn on LED2 is delayed by $(t_{PLH\ max} - t_{PHL\ min})$ from the LED1 turn off. Note that the propagation delays used to calculate PDD are taken at equal temperatures since the optocouplers under consideration are typically mounted in close proximity to each other. (Specifically, $t_{PLH\ max}$ and $t_{PHL\ min}$ in the previous equation are not the same as the $t_{PLH\ max}$ and $t_{PHL\ min}$ over the full operating temperature range, specified in the data sheet.) This delay is the maximum value for the propagation delay difference specification, which is specified at 450 ns for the HCPL-4506 series over an operating temperature range of -40°C to 100°C .

Delaying the LED signal by the maximum propagation delay difference ensures that the minimum dead time is zero, but it does not tell a designer what the maximum dead time will be. The maximum dead time occurs in the highly unlikely case where one optocoupler with the fastest t_{PLH} and another with the slowest t_{PHL} are in the same inverter leg. The maximum dead time in this case becomes the sum of the spread in the t_{PLH} and t_{PHL} propagation delays as shown in [Figure 37](#). The maximum dead time is also equivalent to the difference between the maximum and minimum propagation delay difference specifications. The maximum dead time (due to the optocouplers) for the HCPL-4506 series is 600 ns ($= 450\ \text{ns} - (-150\ \text{ns})$) over an operating temperature range of -40°C to 100°C .

Copyright © 2005–2022 Broadcom. All Rights Reserved. The term “Broadcom” refers to Broadcom Inc. and/or its subsidiaries. For more information, go to www.broadcom.com. All trademarks, trade names, service marks, and logos referenced herein belong to their respective companies.

Broadcom reserves the right to make changes without further notice to any products or data herein to improve reliability, function, or design. Information furnished by Broadcom is believed to be accurate and reliable. However, Broadcom does not assume any liability arising out of the application or use of this information, nor the application or use of any product or circuit described herein, neither does it convey any license under its patent rights nor the rights of others.



Looking for pricing, stock, or lifecycle information?

Click below to explore more details on WIN SOURCE:

 [View HCPL-0466-000E on WIN SOURCE](#)

 [Broadcom Limited](#) Information

Optimize Your Supply Chain with WIN SOURCE Solutions

-  Global Sourcing Solution
-  Obsolete Management
-  Cost Control Management
-  Shortage Management
-  Alternative Solution
-  Excess Inventory Management