



**THE DATASHEET OF
AI-WB2-M1-I**





Ai-WB2-M1-I Specification

Version V1.0.0

Copyright ©2022

Content

1. Product overview	4
1.1. Characteristic	5
2. Main parameters	6
2.1. Static electricity requirement	6
2.2. Electrical characteristics	7
2.3. Wi-Fi RF Performance	7
2.4. BLE RF Performance	8
2.5. Power	8
3. Appearance dimensions	9
4. Pin definition	10
5. Schematic	12
6. Antenna parameters	13
6.1. Antenna test prototype signal	13
6.2. Recommend PCB footprint size	14
6.3. Antenna layout requirements	14
6.4. Power supply	14
6.5. GPIO	16
7. Storage conditions	17
8. Reflow welding curve diagram	17
9. Product Packaging Information	18
10. Contact us	18
Disclaimer and copyright notice	19
Notice	19

1. Product overview

Ai-WB2-M1-I is a Wi-Fi&BT module developed by Shenzhen Ai-Thinker Technology Co., LTD. The module is equipped with BL602 chip as the core processor and supports Wi-Fi 802.11b/ g/n protocol and BLE 5.0 protocol. The BL602 chip has a low-power 32-bit RISC CPU, 276KB RAM, and a wealth of peripheral interfaces, including SDIO, SPI, UART, I2C, IR Remote, PWM, ADC, DAC, PIR and GPIO etc. It can be widely used in Internet of Things (IoT), mobile devices, wearable electronic devices, smart home and other fields.

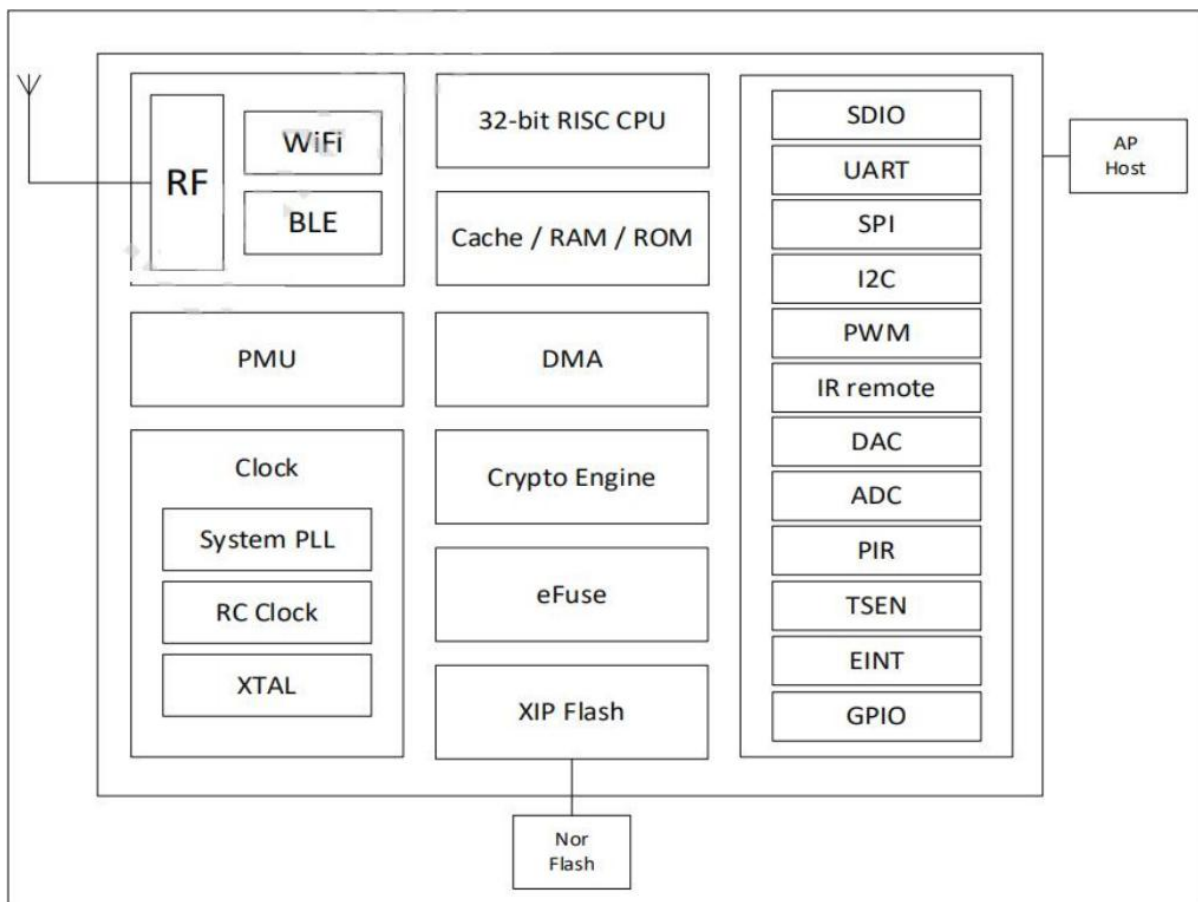

Figure 1 Main chip block diagram

1.1. Characteristic

- The package is SMD-61
- Support IEEE 802.11 b/g/n protocol
- Wi-Fi Security Support WPS/WEP/WPA/WPA2 Personal/WPA2 Enterprise/WPA3
- Support 20MHz bandwidth and Max rate is 72.2 Mbps
- Bluetooth BLE 5.0, Bluetooth Mesh
- Support Station + BLE mode、 Station + SoftAP + BLE mode
- Support 32-bit RISC CPU, 276KB RAM
- Secure start-up, supports mirroring with ECC-256 signature
- Support QSPI/SPI Flash On-The-Fly AES Decryption, support AES 128 CTR mode
- Support AES 128/192/256-bit encryption engine
- Support SHA-1/224/256
- Support true Random number generator (TRNG)
- Public key Accelerator (PKA), support large number basic operations, software provides signature, verification and other application program interface
- Support SDIO, SPI, UART, I2C, IR remote, PWM, ADC, DAC, PIR, GPIO etc
- Integrated Wi-Fi MAC/BB/RF/PA/LNA/BT
- Support a variety of sleep modes, deep sleep current 12 μ A
- Universal AT instruction for quick start
- Support secondary development, integrated Windows, Linux development environment

2. Main parameters

Table 1 Description of the main parameters

Model	Ai-WB2-M1-I
Package	SMD-61
Size	12.5*13.2*2.4(±0.2)mm
Antenna	IPEX connector
Frequency	2400 ~ 2483.5MHz
Storage temperature	-40°C ~ 85°C
Storage temperature	-40°C ~ 125°C, < 90%RH
Power supply	Support voltage 2.7V~3.6V, supply current≥500mA
Interface	UART/GPIO/ADC/PWM/I2C/SPI
IO	15
UART rate	Default 115200 bps
Security	WPS/WEP/WPA/WPA2 Personal/WPA2 Enterprise/WPA3
Flash	Default 4MByte

2.1. Static electricity requirement

Ai-WB2-M1-I is an electrostatic sensitive device. Therefore, you need to take special precautions when carrying it.



Figure 2 ESD preventive measures

2.2. Electrical characteristics

Table 2 Electrical characteristic table

Parameters	Conditio	Min.	Typical value	Max.	Unit
Voltage Supply	VDD	2.7	3.3	3.6	V
I/O	VIL	-	-	0.3*VDDIO	V
	VIH	-	0.7*VDDIO	-	V
	VOL	-	-	0.1*VDDIO	V
	VOH	-	-	0.9*VDDIO	V
	IMAX	-	-	-	15

2.3. Wi-Fi RF Performance

Table 3 Wi-Fi RF performance table

Description	Typical value			Unit
Frequency range	2400 ~ 2483.5MHz			MHz
Output Power				
Mode	Min.	Typical value	Max.	Unit
11n Mode HT20, PA output power	-	16	-	dBm
11g Mode, PA output power	-	17	-	dBm
11b Mode, PA output power	-	19	-	dBm
Receive Sensitivity				
Mode	Min.	Typical value	Max.	Unit
11b, 1 Mbps	-	-98	-	dBm
11b, 11 Mbps	-	-90	-	dBm
11g, 6 Mbps	-	-93	-	dBm
11g, 54 Mbps	-	-76	-	dBm
11n, HT20 (MCS7)	-	-73	-	dBm

2.4. BLE RF Performance

Table 4 BLE RF performance table

Description	Typical value			Unit
Frequency range	2400 ~ 2483.5MHz			MHz
Output Power				
Rate Mode	Min.	Typical value	Max.	Unit
1Mbps	-	9	15	dBm
Receive Sensitivity				
Rate Mode	Min.	Typical value	Max.	Unit
1Mbps sensitivity@30.8%PER	-	-96	-	dBm

2.5. Power

The following power consumption data are based on a 3.3V power supply, 25°C ambient temperature, and measured using an internal voltage regulator.

- All measurements are made at the antenna interface with a filter.
- All transmission data are based on 100% duty cycle in continuous transmission mode.

Table 5 Power consumption table

Mode	Min.	AVG	Max.	Unit
Tx 802.11b, 11Mbps, POUT=+21dBm	-	260	-	mA
Tx 802.11g, 54Mbps, POUT =+18dBm	-	245	-	mA
Tx 802.11n, MCS7, POUT =+17dBm	-	230	-	mA
Rx 802.11b,packet length 1024 byte	-	65	-	mA
Rx 802.11g,packet length 1024 byte	-	65	-	mA
Rx 802.11n,Packet length 1024 byte	-	65	-	mA
Deep-Sleep	-	12	-	μA

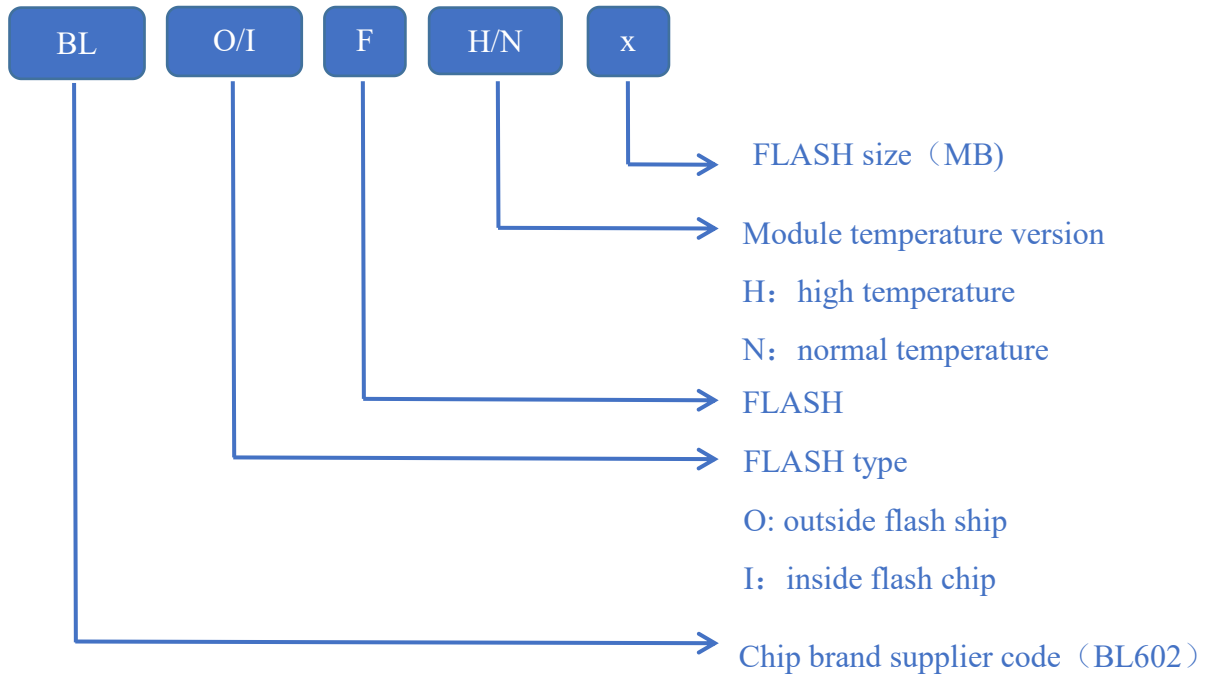

Figure 5 Shield printing information

4. Pin definition

Ai-WB2-M1-I module is connected with a total of 61 pins, as shown in the pin schematic diagram, pin function definition table is the interface definition.

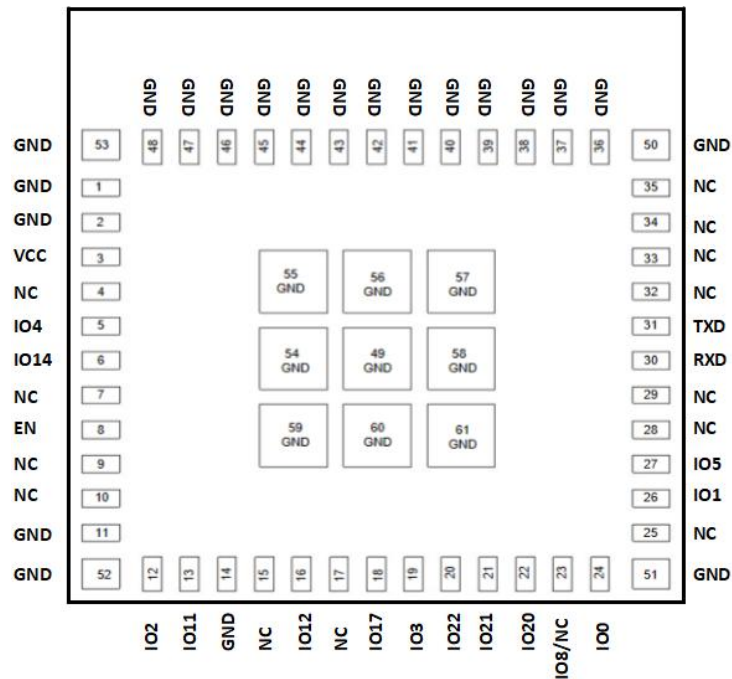

Figure 6 Schematic diagram of module pins

Table 6 pin function definition table

No.	Name	Function
1,2,11,14, 36-61	GND	Ground
3	VCC	3.3V power supply; It is recommended that the output current of the external power supply be higher than 500mA
4,7,9,10,15 ,17,25,28, 29,32-35	NC	NC, not available to use
5	IO4	GPIO4/SPI_MOSI/MISO/IIC_SCL/PWM_CH4/ADC_CH4
6	IO14	GPIO14/SPI_SS/IIC_SCL/PWM_CH4/ADC_CH2
8	EN	Default chip enable pin, active-high, high level effective.
12	IO2	GPIO2/SPI_SS/IIC_SCL/PWM_CH2
13	IO11	GPIO11/SPI_SCLK/IIC_SDA/ADC_CH10
16	IO12	GPIO12/SPI_MOSI/MISO/IIC_SCL/PWM_CH2/ADC_CH0
18	IO17	GPIO17/SPI_MOSI/MISO/IIC_SDA/PWM_CH2
19	IO3	GPIO3/SPI_SCLK/IIC_SDA/PWM_CH3
20	IO22	GPIO22/SPI_SS/IIC_SCL/PWM_CH2/JTAG_TCK/TMS
21	IO21	GPIO21/SPI_MOSI/MISO/IIC_SDA/PWM_CH1/JTAG_TDI/TDO
22	IO20	GPIO20/SPI_MOSI/MISO/IIC_SCL/PWM_CH0/JTAG_TMS/TCK
23	IO8/NC	NC, unavailable. If you need to use it, please contact Ai-Thinker. Bootstrap/GPIO8/SPI_MOSI/MISO/IIC_SCL/PWM_CH3
24	IO0	GPIO0/SDIO_CLK//SPI_MOSI/MISO/IIC_SCL/PWM_CH0/JTAG_TMS/TCK
26	IO1	GPIO1/SPI_MOSI/MISO/IIC_SDA/PWM_CH1
27	IO5	GPIO5/SPI_MOSI/MISO/IIC_SDA/PWM_CH0/ADC_CH4
30	RXD	RXD/GPIO7/SPI_SCLK/IIC_SDA/PWM_CH2
31	TXD	TXD/GPIO16/SPI_MOSI/MISO/IIC_SCL/PWM_CH1

Note:

1. At the moment of power-on, if Bootstrap GPIO8 is high, the module enters the programming mode; if Bootstrap GPIO8 is low, the module starts normally.

5. Schematic

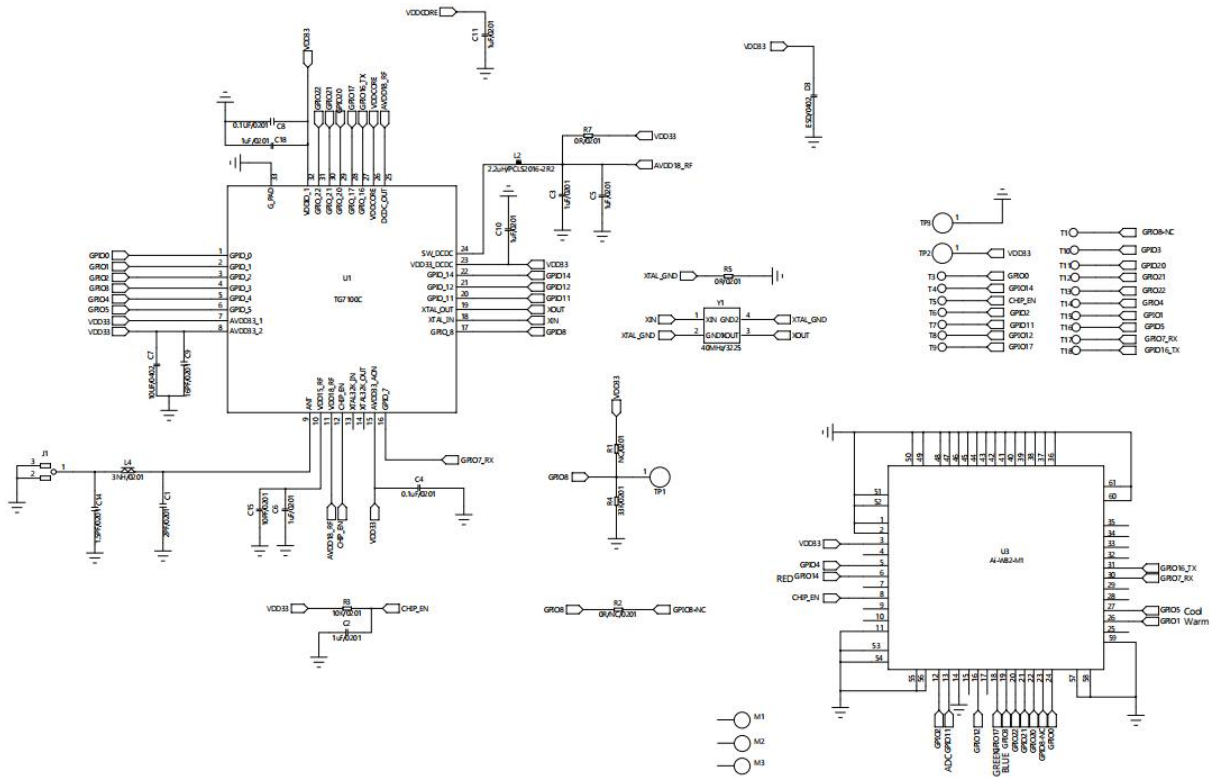

Figure 7 Module schematic

6. Antenna parameters

6.1. Antenna test prototype signal

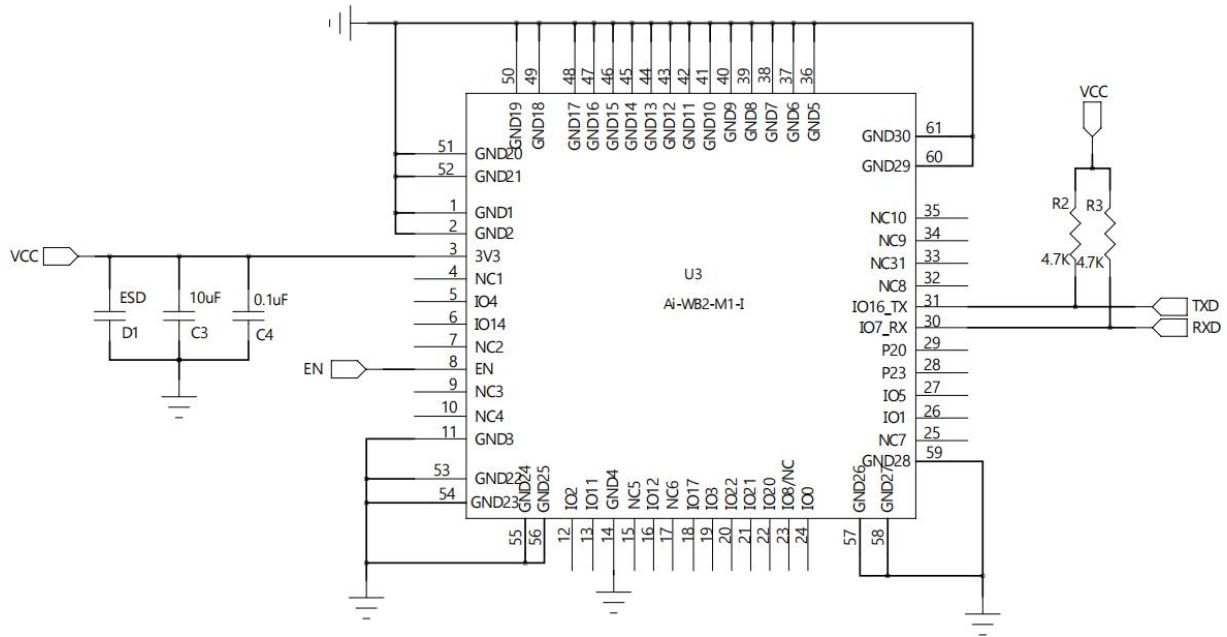

Figure 8 Application circuit diagram

- If the IO port is used as PWM, it is recommended to reserve a 4.7K pull-down resistor around the module. Especially in the application of light control, it can prevent the flashing light phenomenon at the moment of power-on start.
- IO8/NC pins, which are not available by default. If you need to use it, please contact Ai-Thinker.

6.2. Recommend PCB footprint size



图 9 推荐 PCB 封装尺寸

- When making the PCB patch package, please pay attention to the welding pad does not shrink into the module inside, to prevent a short circuit to the back test point and leading to poor patch.

6.3. Antenna layout requirements

- The module is required to be used by an external antenna.
- In order to meet the performance of the antenna, the metal parts are not placed around the antenna, away from the high-frequency devices.

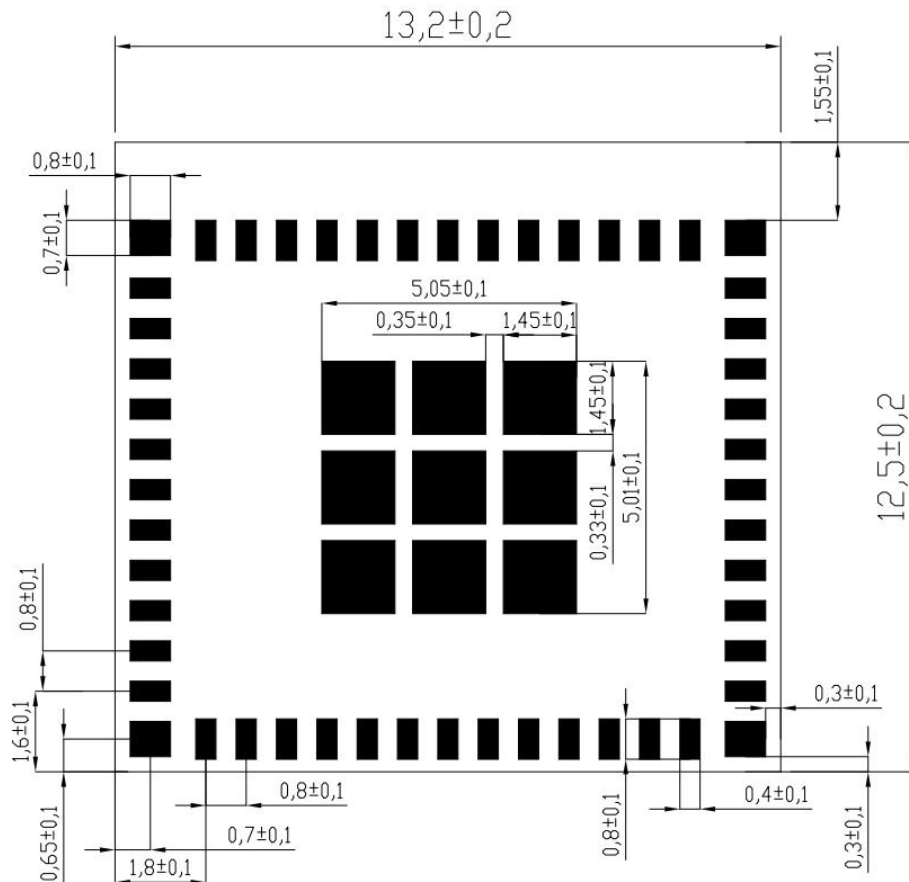
6.4. Power supply

- Recommended 3.3V voltage, peak current above 500mA.
- Power supply is recommend to use LDO; if the DC-DC is used, the ripple is recommended to be controlled within 30mV

- DC-DC power supply circuit proposes to reserve the dynamic response capacitance to optimize the output ripple with large load changes.
- It is recommended to add ESD devices to the 3.3V power interface.

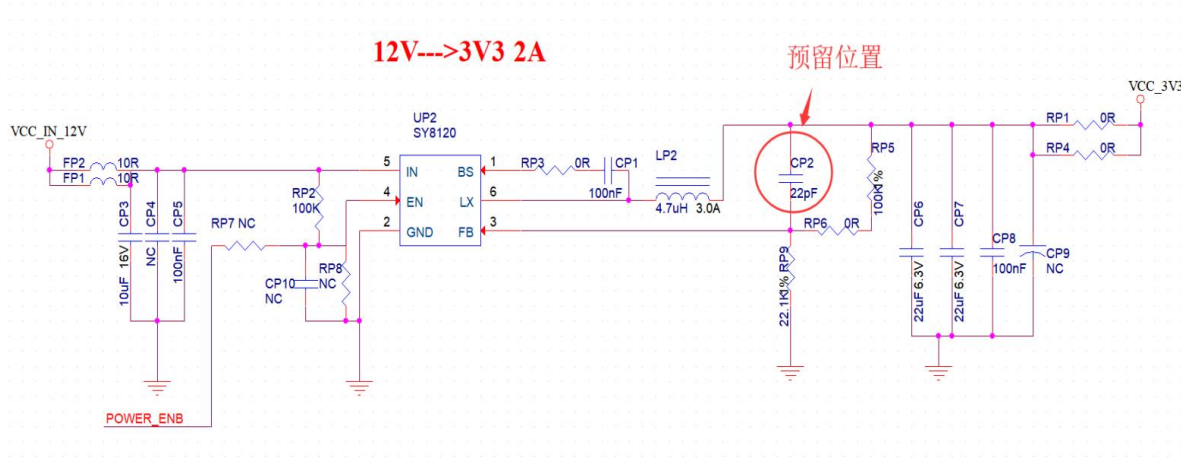

Figure 10 DC-DC step-down circuit diagram

6.5. GPIO

- There are some IO ports on the periphery of the module. If you need to use it, it is recommended to connect a 10-100 ohm resistor in series with the IO port. This inhibits overshoot and makes both sides level more stable. It is helpful for EMI and ESD.
- For special I/O ports to be pulled up and down, refer to the direction for use in the specifications, which may affect the module start-up configuration.
- The IO port of the module is 3.3V. If the IO level of the main control and the module do not match, a level convert circuit needs to be added.
- If the I/O port is directly connected to a peripheral port or terminals, for example, a pin row, reserve an ESD device near the terminal of the I/O cable.

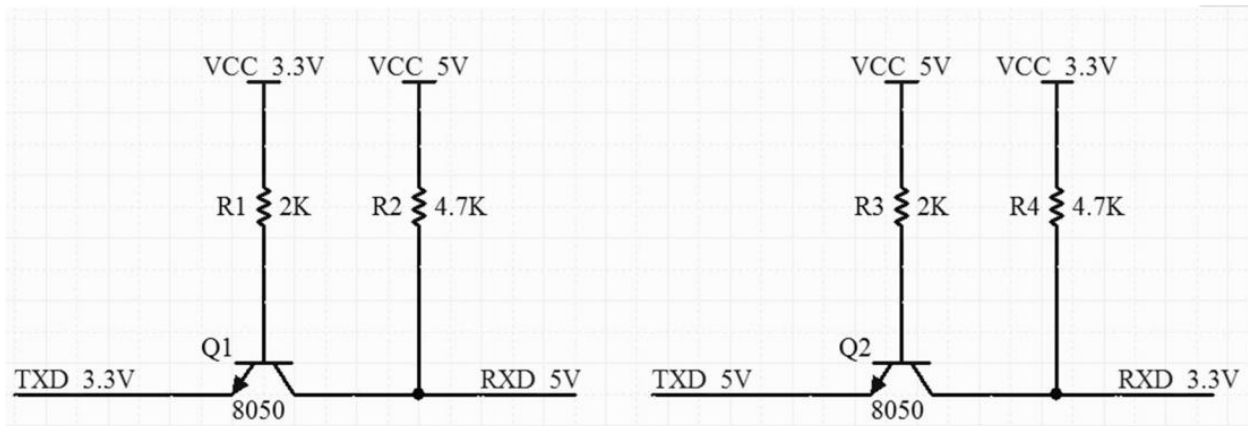

Figure 11 Level convert circuit

7. Storage conditions

Products sealed in moisture-proof bags should be stored in a non-condensing atmosphere of <math><40\text{ }^\circ\text{C}/90\%\text{RH}</math>.

The module has a moisture sensitivity rating of MSL 3.

After the vacuum bag is opened, it must be used within 168 hours at $25\pm 5^\circ\text{C}/60\%\text{RH}$, otherwise it needs to be baked before it can be put on line again.

8. Reflow welding curve diagram

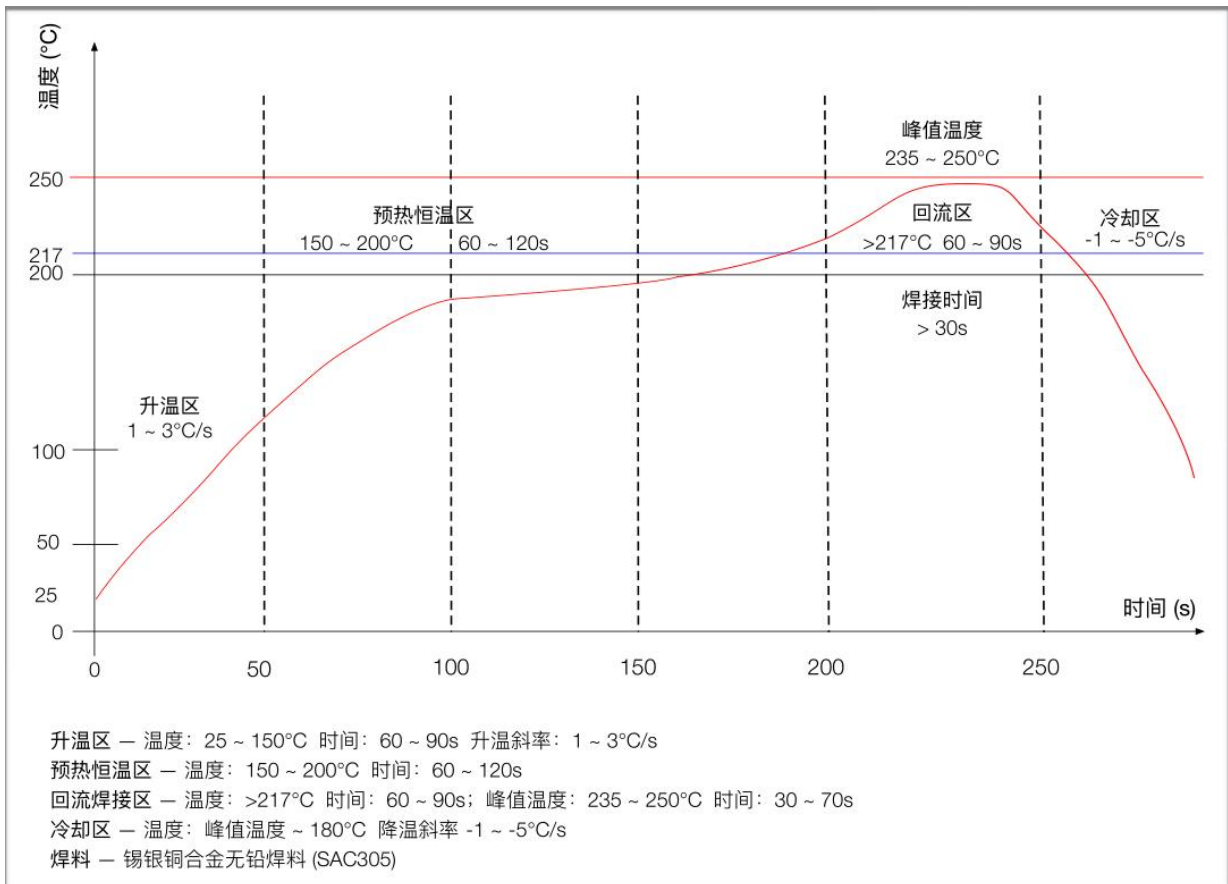

Figure 12 Reflow welding diagram

9. Product Packaging Information

Ai-WB2-M1-I module was packaged in a tape, 800pcs/reel. As shown in the below image::



Figure 13 Package and packing diagram

10. Contact us

[Ai-Thinker official website](#)

[Office forum](#)

[Develop DOCS](#)

[LinkedIn](#)

[Tmall shop](#)

[Taobao shop](#)

[Alibaba shop](#)

[Technical support email: support@aithinker.com](mailto:support@aithinker.com)

[Domestic business cooperation: sales@aithinker.com](mailto:sales@aithinker.com)

[Overseas business cooperation: overseas@aithinker.com](mailto:overseas@aithinker.com)

Company Address: Room 403,408-410, Block C, Huafeng Smart Innovation Port, Gushu 2nd Road, Xixiang, Baoan District, Shenzhen.

Tel: +86-0755-29162996



WeChat mini program



WeChat official account

Disclaimer and copyright notice

The information in this article, including the URL address for reference, is subject to change without notice.

The document is provided "as is" without any guarantee responsibility, including any guarantee for merchantability, suitability for a specific purpose, or non-infringement, and any guarantee mentioned elsewhere in any proposal, specification or sample. This document does not bear any responsibility, including the responsibility for infringement of any patent rights arising from the use of the information in this document. This document does not grant any license for the use of intellectual property rights in estoppel or other ways, whether express or implied.

The test data obtained in the article are all obtained from Ai-Thinker's laboratory tests, and the actual results may vary slightly.

All brand names, trademarks and registered trademarks mentioned in this article are the property of their respective owners, and it is hereby declared.

The final interpretation right belongs to Shenzhen Ai-Thinker Technology Co., Ltd.

Notice



Due to product version upgrades or other reasons, the contents of this manual may be changed.

Shenzhen Ai-Thinker Technology Co., Ltd. reserves the right to modify the contents of this manual without any notice or prompt.





This manual is only used as a guide. Shenzhen Ai-Thinker Technology Co., Ltd. makes every effort to provide accurate information in this manual. However, Shenzhen Ai-Thinker Technology Co., Ltd. does not guarantee that the contents of the manual are completely free of errors. All statements and information in this manual And the suggestion does not constitute any express or implied guarantee.

Looking for pricing, stock, or lifecycle information?

Click below to explore more details on WIN SOURCE:

-  [View AI-WB2-M1-I on WIN SOURCE](#)
-  [Ai-Thinker Information](#)

Optimize Your Supply Chain with WIN SOURCE Solutions

-  Global Sourcing Solution
-  Obsolete Management
-  Cost Control Management
-  Shortage Management
-  Alternative Solution
-  Excess Inventory Management