



**THE DATASHEET OF
NFA50460R4B**



Motion SPM[®] 5 Series

NFA50460R4B, NFA50460R47

General Description

The NFA50460R4B/7 is an advanced Motion SPM5 module providing a fully featured, high performance inverter output stage for AC induction, BLDC and PMSM motors such as refrigerators, fans and pumps. These modules integrate optimized gate drive of the built-in IGBTs (FS4 RC IGBT technology) to minimize EMI and losses, while also providing multiple on-module protection features including under-voltage lockouts and thermal monitoring. The built-in high speed Driver IC requires only a single supply voltage and translates the incoming logic-level gate inputs to the high voltage, high current drive signals required to properly drive the module's internal IGBTs. Separate open emitter IGBT terminals are available for each phase to support the widest variety of control algorithms.

Features

- UL Certified No. E209204 (UL1557)
- 600 V FS4 RC IGBT 3-Phase Inverter with Gate Drivers and Protection
- Built-In Bootstrap Diodes Simplify PCB Layout
- Separate Open-Emitter Pins from Low-Side IGBTs for Three-Phase Current-Sensing
- Active-High Interface, Works with 3.3 / 5 V Logic, Schmitt-Trigger Input
- Optimized for Low Electromagnetic Interference
- Driver IC Temperature Sensing Built-In for Temperature Monitoring
- Driver IC for Gate Driving and Under-Voltage Protection
- Isolation Rating: 1500 V_{rms}/min.
- Moisture Sensitive Level (MSL) 3 for SMD PKG
- RoHS Compliant

Applications

- 3-Phase Inverter Driver for Small Power AC Motor Drives

Related Source

- [AN-9080 – Motion SPM[®] 5 Series Version 2 User's Guide](#)
- [AN-9082 – Motion SPM[®] 5 Series Thermal Performance by Contact Pressure](#)

SPM5P-023 / 23LD, PDD STD,
 FULL PACK, DIP TYPE
 CASE MODEJ

SPM5Q-023 / 23LD, PDD STD,
 SPM23-BD (Ver1.5) SMD TYPE
 CASE MODEM

MARKING DIAGRAM

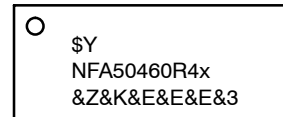

\$Y = onsemi Logo
 NFA50460R4x = Specific Device Code
 → x = B or 7
 &Z = Assembly Plant Code
 &K = Lot Traceability Code
 &3 = Date Code (Year & Week)

ORDERING INFORMATION

See detailed ordering and shipping information on page 2 of this data sheet.

NFA50460R4B, NFA50460R47

ORDERING INFORMATION

Device	Device Marking	Package	Packing Type [†]	Reel Size	Quantity
NFA50460R4B	NFA50460R4B	SPM5P-023	Rail	NA	15
NFA50460R47	NFA50460R47	SPM5Q-023	Tape & Reel	330 mm	450

[†]For information on tape and reel specifications, including part orientation and tape sizes, please refer to our Tape and Reel Packaging Specifications Brochure, BRD8011/D.

ABSOLUTE MAXIMUM RATINGS ($V_{DD} = V_{BS} = 15\text{ V}$, $T_C = 25^\circ\text{C}$, unless otherwise noted)

Symbol	Parameter	Conditions	Rating	Unit
--------	-----------	------------	--------	------

INVERTER PART (Each IGBT Unless Otherwise Specified)

V_{PN}	Supply Voltage	Applied between P – N_U , N_V , N_W	450	V
$V_{PN(\text{Surge})}$	Supply Voltage (Surge)	Applied between P – N_U , N_V , N_W	500	V
V_{CES}	Collector – Emitter Voltage		600	V
$\pm I_C$	Each IGBT Collector Current	$T_C = 25^\circ\text{C}$, $V_{DD} = 15\text{ V}$, $T_J < 150^\circ\text{C}$	4	A
$\pm I_{CP}$	Each IGBT Collector Current, Peak	$T_C = 25^\circ\text{C}$, $V_{DD} = 15\text{ V}$, $T_J < 150^\circ\text{C}$, Under 1 ms Pulse Width (Note 2)	8	A
P_C	Collector Dissipation	$T_C = 25^\circ\text{C}$ per One Chip (Note 2)	10.3	W
T_J	Operating Junction Temperature		-40~150	$^\circ\text{C}$

CONTROL PART (Each IC Unless Otherwise Specified)

V_{DD}	Control Supply Voltage	Applied between V_{DD} and V_{SS}	20	V
V_{BS}	High-Side Control Bias Voltage	Applied between V_B and V_S	20	V
V_{IN}	Input Signal Voltage	Applied between H_{IN} , L_{IN} and V_{SS}	-0.3~ $V_{DD} + 0.3$	V

BOOTSTRAP DIODE PART (Each Bootstrap Diode Unless Otherwise Specified)

V_{RRM}	Maximum Repetitive Reverse Voltage		600	V
I_F	Forward Current	$T_C = 25^\circ\text{C}$, $T_J < 150^\circ\text{C}$ (Note 2)	0.5	A
I_{FP}	Forward Current (Peak)	$T_C = 25^\circ\text{C}$, $T_J < 150^\circ\text{C}$, Under 1 ms Pulse Width (Note 2)	1.5	A

THERMAL RESISTANCE

$R_{th(j-c)Q}$	Junction to Case Thermal Resistance	Inverter IGBT Part (per 1/6 Module) (Note 1)	12.2	$^\circ\text{C/W}$
----------------	-------------------------------------	---	------	--------------------

TOTAL SYSTEM

t_{SC}	Short Circuit Withstand Time	$V_{DD} = V_{BS} \leq 16.5\text{ V}$, $V_{PN} \leq 400\text{ V}$, $T_J = 150^\circ\text{C}$, Non-repetitive	3	μs
T_J	Operating Junction Temperature		-40~150	$^\circ\text{C}$
T_{STG}	Storage Temperature		-40~125	$^\circ\text{C}$
V_{ISO}	Isolation Voltage	60 Hz, Sinusoidal, AC 1 minute, Connect Pins to Heat Sink Plate	1500	V_{rms}

Stresses exceeding those listed in the Maximum Ratings table may damage the device. If any of these limits are exceeded, device functionality should not be assumed, damage may occur and reliability may be affected.

- For the measurement point of case temperature T_C , Please refer to Figure 4.
- These values had been made an acquisition by the calculation considered to design factor.
- Using continuously under heavy loads or excessive assembly conditions (e.g. the application of high temperature/ current/ voltage and the significant change in temperature, etc.) may cause this product to decrease in the reliability significantly even if the operating conditions (i.e. operating temperature/ current/ voltage, etc.) are within the absolute maximum ratings and the operating ranges.

NFA50460R4B, NFA50460R47

PIN DESCRIPTION

Pin No.	Pin Name	Description
1	V _{SS}	IC Common Supply Ground
2	V _{B(U)}	High-Side Bias Voltage for U phase IGBT Driving
3	V _{DD(U)}	Low-Side Bias Voltage for U phase IC and IGBT Driving
4	HIN _(U)	Signal Input for High-Side U Phase
5	LIN _(U)	Signal Input for Low-Side U Phase
6	N.C	N.C
7	V _{B(V)}	High-Side Bias Voltage for V phase IGBT Driving
8	V _{DD(V)}	Low-Side Bias Voltage for V phase IC and IGBT Driving
9	HIN _(V)	Signal Input for High-Side V Phase
10	LIN _(V)	Signal Input for Low-Side V Phase
11	VTS	Voltage Output for IC Temperature Sensing Unit
12	V _{B(W)}	High-Side Bias Voltage for W phase IGBT Driving
13	V _{DD(W)}	Low-Side Bias Voltage for W phase IC and IGBT Driving
14	HIN _(W)	Signal Input for High-Side W Phase
15	LIN _(W)	Signal Input for Low-Side W Phase
16	N.C	N.C
17	P	Positive DC-Link Input
18	U, V _{S(U)}	Output for U Phase & High-Side Bias Voltage GND for U phase IGBT Driving
19	N _U	Negative DC-Link Input for U Phase
20	N _V	Negative DC-Link Input for V Phase
21	V, V _{S(V)}	Output for V Phase & High-Side Bias Voltage GND for V phase IGBT Driving
22	N _W	Negative DC-Link Input for W Phase
23	W, V _{S(W)}	Output for W Phase & High-Side Bias Voltage GND for W phase IGBT Driving

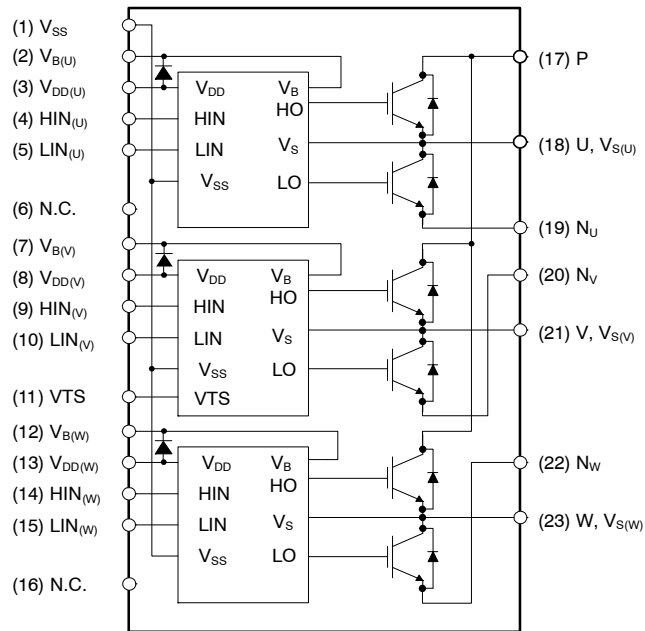

Figure 1. Pin Configuration and Internal Block Diagram (Bottom View)

NOTE:

4. Emitter terminal of each low-side IGBT is not connected to supply ground or bias voltage ground inside Motion SPM 5 product. External connections should be made as indicated in Figure 3.

NFA50460R4B, NFA50460R47

ELECTRICAL CHARACTERISTICS ($T_J = 25^\circ\text{C}$, $V_{DD} = V_{BS} = 15\text{ V}$ unless otherwise noted)

Symbol	Parameter	Test Conditions	Min.	Typ.	Max.	Unit
--------	-----------	-----------------	------	------	------	------

INVERTER PART (Each IGBT unless otherwise specified)

BV_{CES}	Collector–Emitter Breakdown Voltage	$V_{IN} = 0\text{ V}$, $I_D = 1\text{ mA}$ (Note 5)	600	–	–	V
I_{CES}	Collector–Emitter Leakage Current	$V_{IN} = 0\text{ V}$, $V_{CE} = 600\text{ V}$	–	–	1	mA
$V_{CE(SAT)}$	Collector–Emitter Saturation Voltage	$V_{DD} = V_{BS} = 15\text{ V}$, $V_{IN} = 5\text{ V}$, $I_C = 4\text{ A}$, $T_J = 25^\circ\text{C}$	–	1.75	2.2	V
		$V_{DD} = V_{BS} = 15\text{ V}$, $V_{IN} = 5\text{ V}$, $I_C = 4\text{ A}$, $T_J = 150^\circ\text{C}$	–	2.0	–	
V_F	Emitter–Collector Forward Voltage	$V_{IN} = 0\text{ V}$, $I_F = 4\text{ A}$, $T_J = 25^\circ\text{C}$	–	1.87	2.3	V
		$V_{IN} = 0\text{ V}$, $I_F = 4\text{ A}$, $T_J = 150^\circ\text{C}$	–	2.0	–	
t_{ON}	Switching Times	$V_{PN} = 300\text{ V}$, $V_{DD} = V_{BS} = 15\text{ V}$, $I_C = 4\text{ A}$ $V_{IN} = 0\text{ V} \leftrightarrow 5\text{ V}$, Inductive Load, High– and Low–Side IGBT Switching (Note 6)	–	370	–	ns
t_{OFF}			–	358	–	ns
t_{rr}			–	151	–	ns
E_{ON}			–	150	–	μJ
E_{OFF}			–	35	–	μJ
RBSOA	Reverse–Bias Safe Operating Area	$V_{PN} = 400\text{ V}$, $V_{DD} = V_{BS} = 15\text{ V}$, $I_C = I_{CP}$, $V_{CE} = BV_{CES}$, $T_J = 150^\circ\text{C}$ High– and Low–Side IGBT Switching (Note 7)	Full Square			

CONTROL PART (Each HVIC Unless Otherwise Specified)

I_{QDD}	Quiescent V_{DD} Current	$V_{DD} = 15\text{ V}$, $V_{IN} = 0\text{ V}$	Applied between V_{DD} and V_{SS}	–	–	200	μA
I_{QBS}	Quiescent V_{BS} Current	$V_{BS} = 15\text{ V}$, $V_{IN} = 0\text{ V}$	Applied between $V_{B(U)} - U$, $V_{B(V)} - V$, $V_{B(W)} - W$	–	–	100	μA
I_{PDD}	Operating V_{DD} Supply Current	$V_{DD} - V_{SS}$	$V_{DD} = 15\text{ V}$, $f_{PWM} = 20\text{ kHz}$, duty = 50%, Applied to One PWM Signal Input for Low–Side	–	–	900	μA
I_{PBS}	Operating V_{BS} Supply Current	$V_{B(U)} - V_{S(U)}$, $V_{B(V)} - V_{S(V)}$, $V_{B(W)} - V_{S(W)}$	$V_{DD} = V_{BS} = 15\text{ V}$, $f_{PWM} = 20\text{ kHz}$, Duty = 50%, Applied to One PWM Signal Input for High–Side	–	–	800	μA
UV_{DDE}	Low–Side Under–voltage Protection (Figure 8)	V_{DD} Under–voltage Protection Detection Level		7.4	8.0	9.4	V
UV_{DDR}		V_{DD} Under–voltage Protection Reset Level		8.0	8.9	9.8	V
UV_{BSE}	High–Side Under–voltage Protection (Figure 8)	V_{BS} Under–voltage Protection Detection Level		7.4	8.0	9.4	V
UV_{BSR}		V_{BS} Under–voltage Protection Reset Level		8.0	8.9	9.8	V
V_{TS}	IC Temperature Sensing Voltage Output	$V_{DD} = 15\text{ V}$, $T_{driver} = 25^\circ\text{C}$ (Note 8)		600	790	980	mV
V_{IH}	ON Threshold Voltage	Logic HIGH Level	Applied between H_{IN} , L_{IN} and V_{SS}	–	–	2.9	V
V_{IL}	OFF Threshold Voltage	Logic LOW Level		0.8	–	–	V

BOOTSTRAP DIODE PART (Each bootstrap diode unless otherwise specified)

V_{FB}	Forward Voltage	$I_F = 0.1\text{ A}$, $T_C = 25^\circ\text{C}$ (Note 9)	–	2.5	–	V
t_{rB}	Reverse Recovery Time	$I_F = 0.1\text{ A}$, $T_C = 25^\circ\text{C}$	–	80	–	ns

Product parametric performance is indicated in the Electrical Characteristics for the listed test conditions, unless otherwise noted. Product performance may not be indicated by the Electrical Characteristics if operated under different conditions.

NFA50460R4B, NFA50460R47

RECOMMENDED OPERATING CONDITION

Symbol	Parameter	Conditions	Min.	Typ.	Max.	Unit
V_{PN}	Supply Voltage	Applied between P and N	$> V_{DD}$	300	450	V
V_{DD}	Control Supply Voltage	Applied between V_{DD} and V_{SS}	14.0	15.0	16.5	V
V_{BS}	High-Side Bias Voltage	Applied between V_B and V_S	13.0	15.0	18.5	V
$V_{IN(ON)}$	Input ON Threshold Voltage	Applied between H_{IN} , L_{IN} and V_{SS}	3.0	–	V_{DD}	V
$V_{IN(OFF)}$	Input OFF Threshold Voltage		0	–	0.6	V
t_{dead}	Blanking Time for Preventing Arm-Short	$V_{DD} = V_{BS} = 13.5\sim 16.5$ V, $T_J \leq 150^\circ\text{C}$	1.0	–	–	μs
f_{PWM}	PWM Switching Frequency	$T_J \leq 150^\circ\text{C}$	–	–	20	kHz

Functional operation above the stresses listed in the Recommended Operating Ranges is not implied. Extended exposure to stresses beyond the Recommended Operating Ranges limits may affect device reliability.

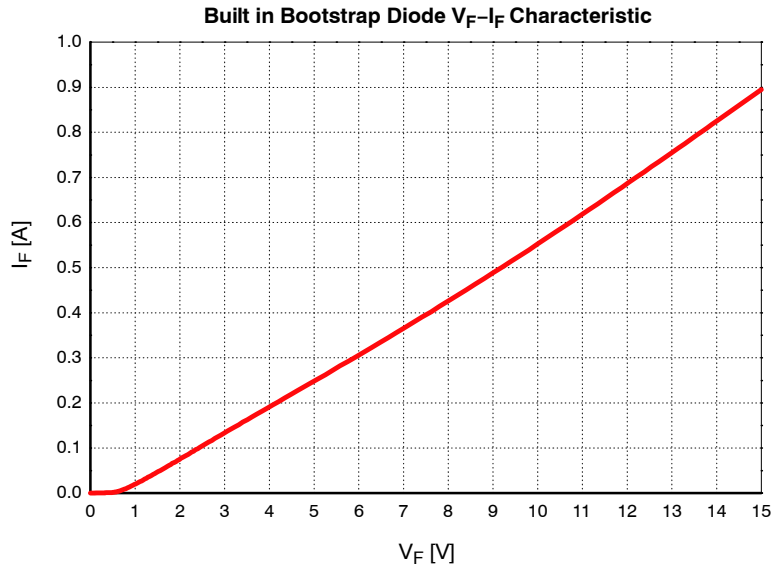

Figure 2. Built-in Bootstrap Diode Characteristics (Typical)

NOTES:

5. BV_{CES} is the absolute maximum voltage rating between collector and emitter terminal of each IGBT inside Motion SPM 5 product. V_{PN} should be sufficiently less than this value considering the effect of the stray inductance so that V_{CE} should not exceed BV_{CES} in any case.
6. t_{ON} and t_{OFF} include the propagation delay time of the internal driver IC. Listed values are measured at the laboratory test condition, and they can be different according to the field applications due to the effect of different printed circuit boards and wirings. Please see Figure 6 for the switching time definition with the switching test circuit of Figure 7.
7. The peak current and voltage of each IGBT during the switching operation should be included in the Safe Operating Area (SOA). Please see Figure 7 for the RBSOA test circuit that is same as the switching test circuit.
8. VTS is only for sensing temperature of module and cannot shutdown IGBTs automatically.
9. Built in bootstrap diode includes around 15Ω resistance characteristic. Please refer to Figure 2.

NFA50460R4B, NFA50460R47

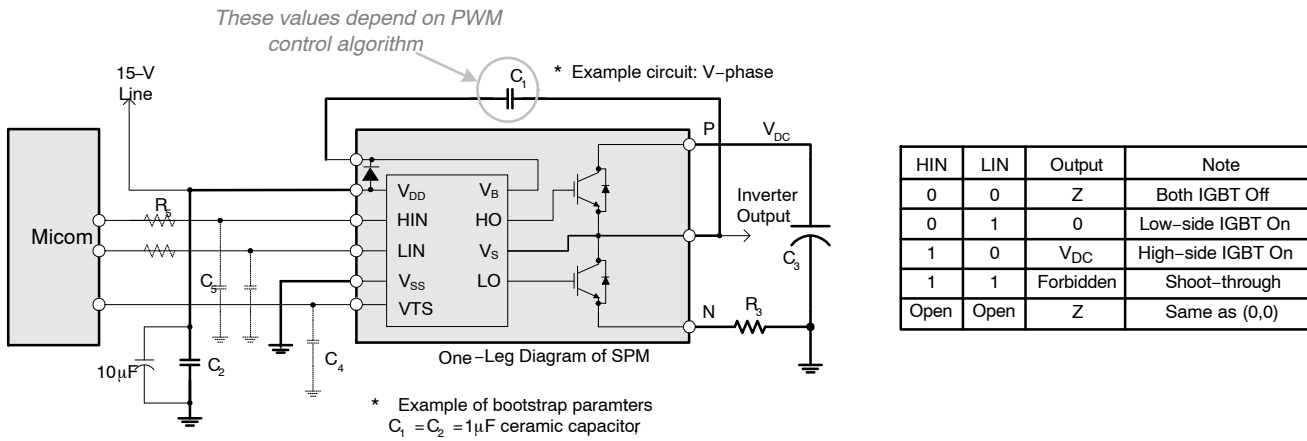

Figure 3. Recommended CPU Interface and Bootstrap Circuit with Parameters

NOTES:

- 10. Parameters for bootstrap circuit elements are dependent on PWM algorithm. Typical example of parameters is shown above.
- 11. RC coupling (R₅ and C₅) and C₄ at each input of SPM and Microm (Indicated as dotted lines) may be used to prevent improper signal due to surge noise.
- 12. Bold lines should be short and thick in PCB pattern to have small stray inductance of circuit, which results in the reduction of surge voltage. Bypass capacitors such as C₁, C₂ and C₃ should have good high-frequency characteristics to absorb high-frequency ripple current.

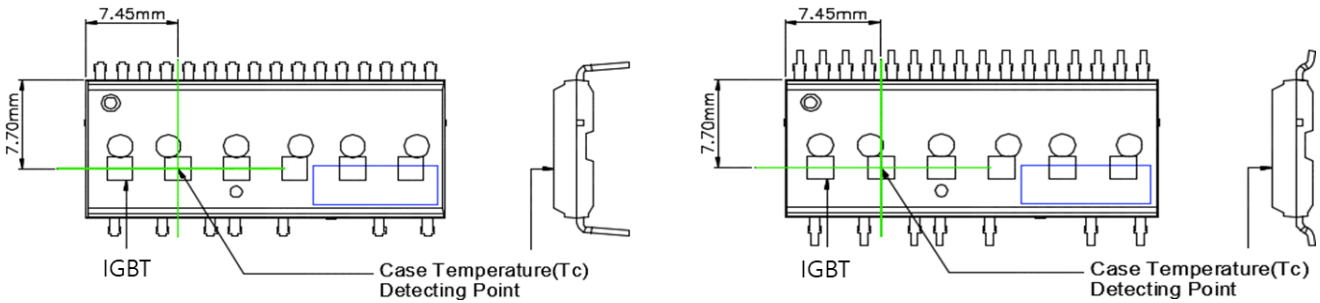

Figure 4. Case Temperature Measurement

NOTE:

- 13. Attach the thermocouple on top of the heatsink-side of SPM (between SPM and heatsink if applied) to get the correct temperature measurement.

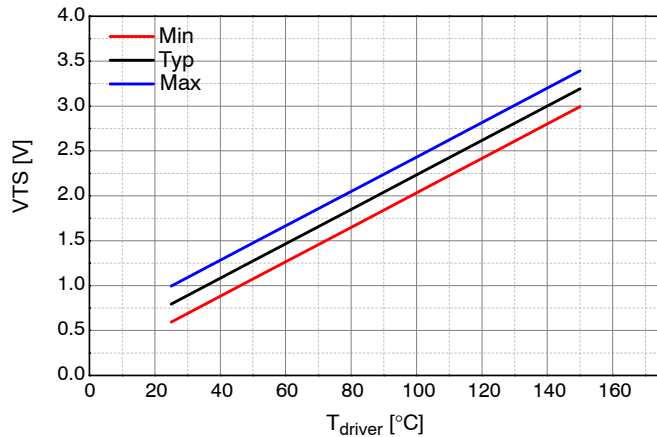

Figure 5. Temperature Profile of VTS

NFA50460R4B, NFA50460R47

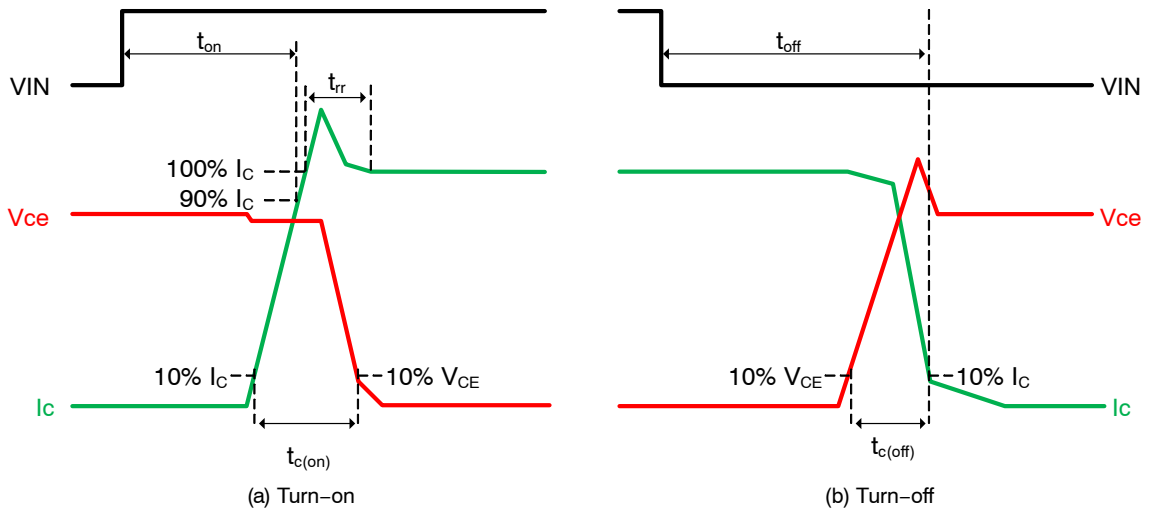

Figure 6. Switching Time Definitions

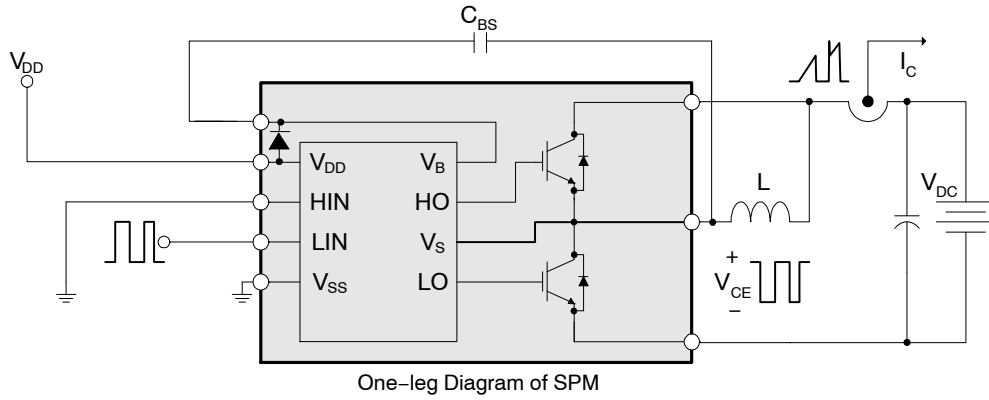

Figure 7. Switching and RBSOA (Single-pulse) Test Circuit (Low-side)

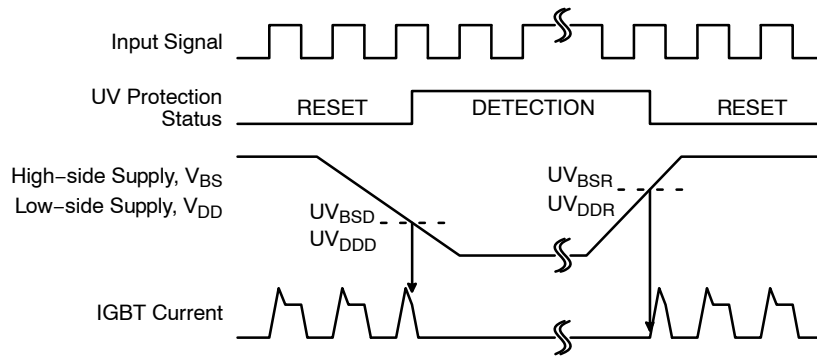

Figure 8. Under-Voltage Protection (High-side and Low-side)

NFA50460R4B, NFA50460R47

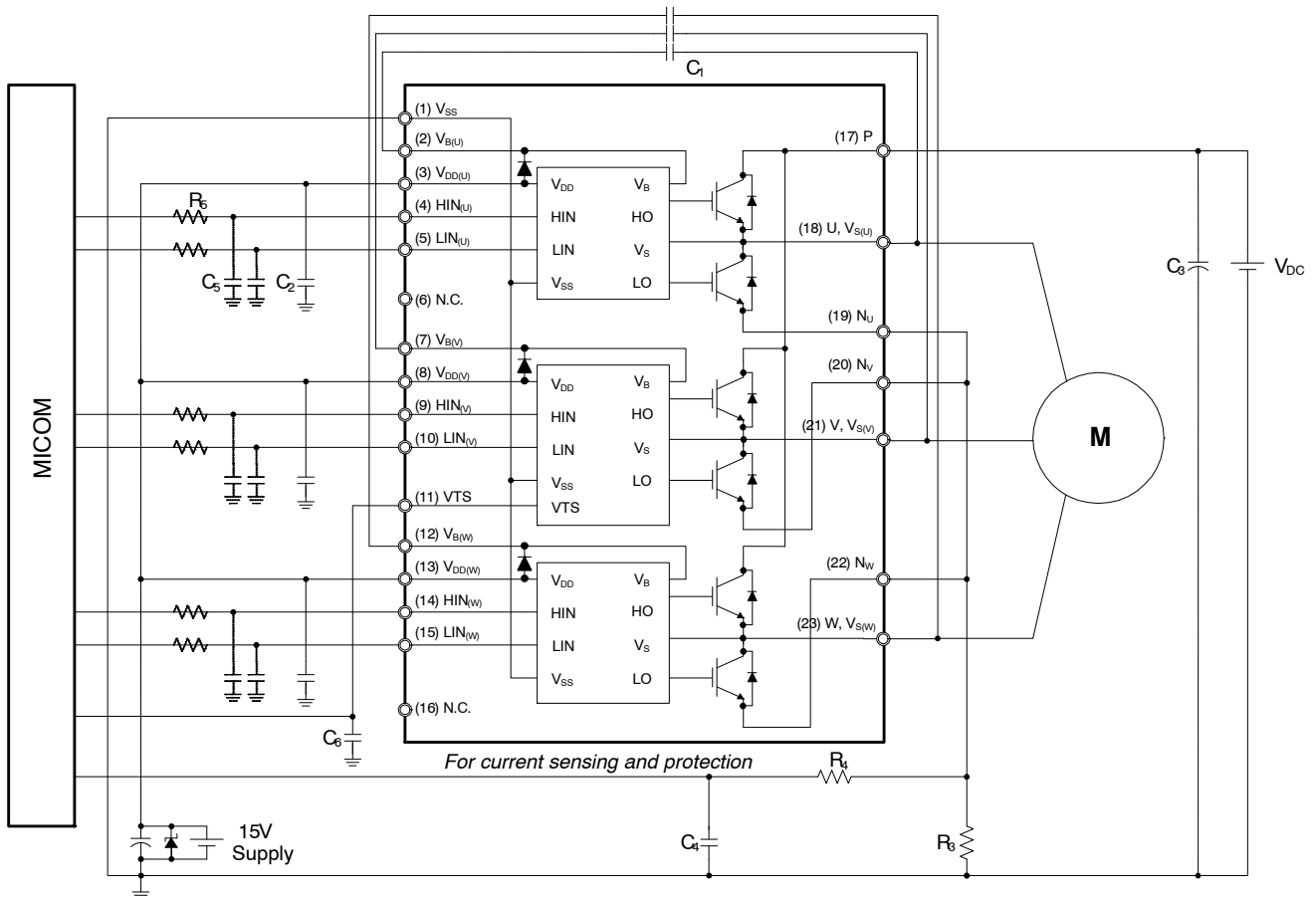

Figure 9. Example of Application Circuit

NOTES:

14. About pin position, refer to Figure 1.
15. RC coupling (R_5 and C_5 , R_4 and C_4) and C_6 at each input of Motion SPM 5 product and Micom are useful to prevent improper input signal caused by surge noise.
16. The voltage drop across R_3 affects the low side switching performance and the bootstrap characteristics since it is placed between V_{SS} and the emitter terminal of the low side IGBT. For this reason, the voltage drop across R_3 should be less than 1 V in the steady-state.
17. Ground wires and output terminals, should be thick and short in order to avoid surge voltage and malfunction of IC.
18. All the filter capacitors should be connected close to Motion SPM 5 product, and they should have good characteristics for rejecting high-frequency ripple current.

TYPICAL PERFORMANCE CHARACTERISTICS

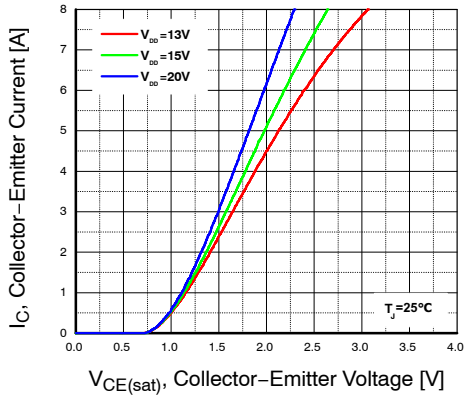

Figure 10. Typ. Collector-Emitter Saturation Voltage

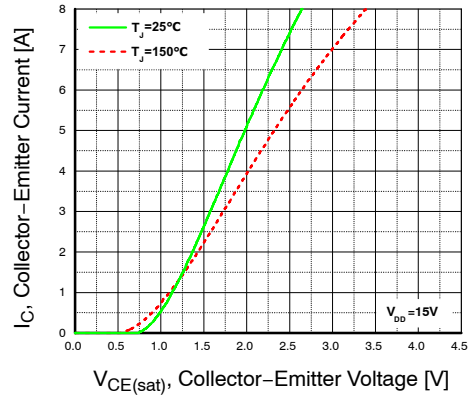

Figure 11. Typ. Collector-Emitter Saturation Voltage

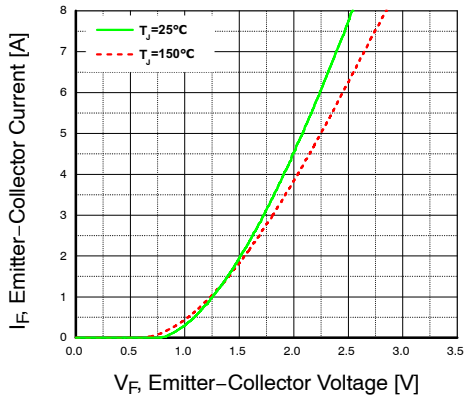

Figure 12. Typ. Emitter-Collector Forward Voltage

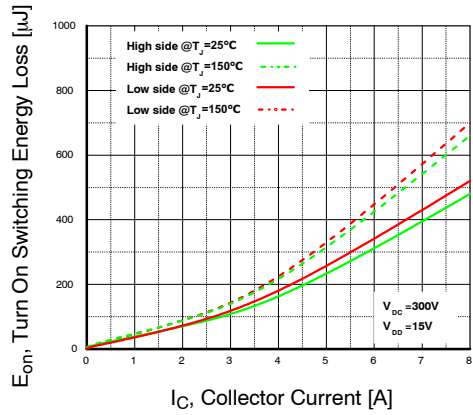

Figure 13. Typ. Turn On Switching Energy Loss

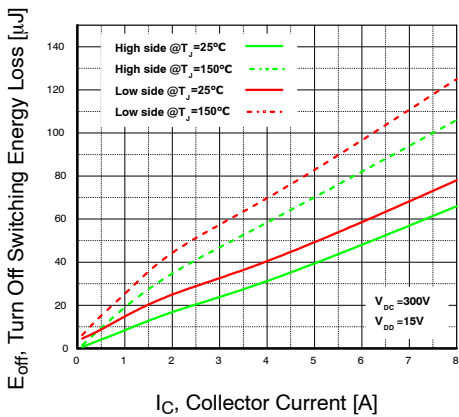

Figure 14. Typ. Turn Off Switching Energy Loss

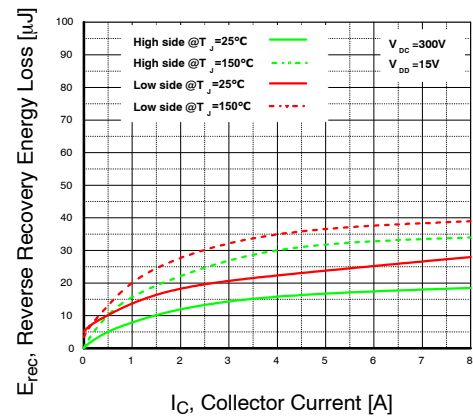

Figure 15. Typ. Reverse Recovery Energy Loss

TYPICAL PERFORMANCE CHARACTERISTICS

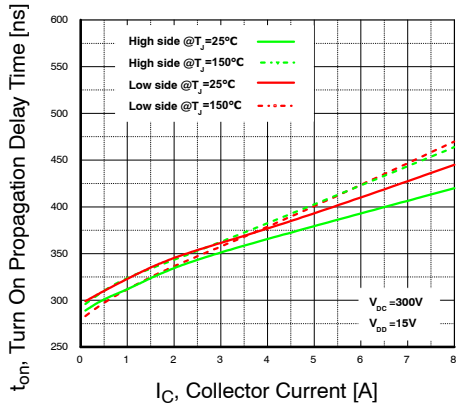

Figure 16. Typ. Turn On Propagation Delay Time

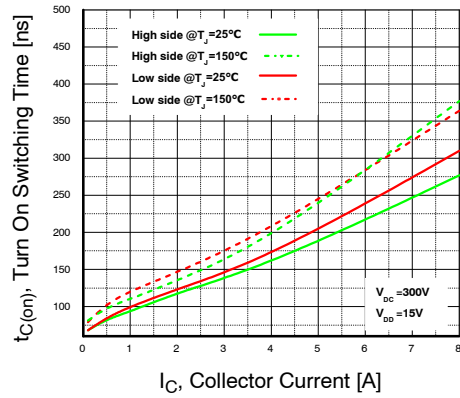

Figure 17. Typ. Turn On Switching Time

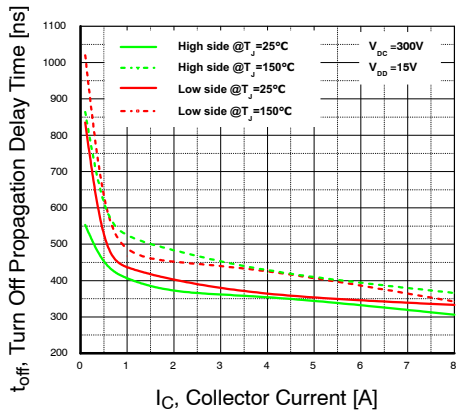

Figure 18. Typ. Turn Off Propagation Delay Time

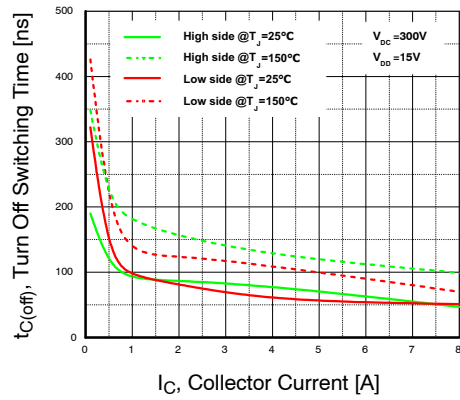

Figure 19. Typ. Turn Off Switching Time

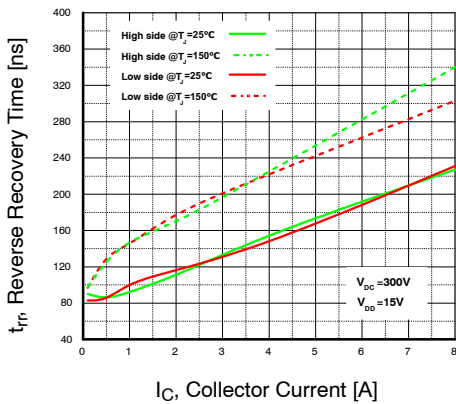

Figure 20. Typ. Reverse Recovery Time

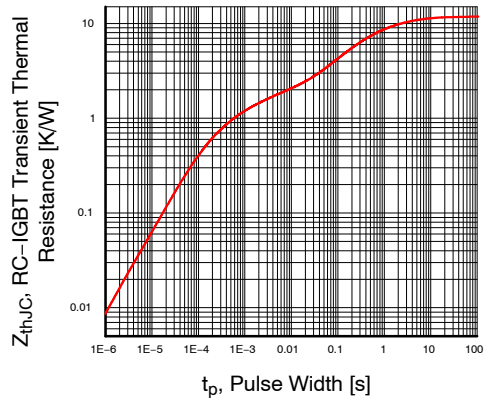

Figure 21. RC-IGBT Transient Thermal Resistance

SPM is registered trademark of Semiconductor Components Industries, LLC dba "onsemi" or its affiliates and/or subsidiaries in the United States and/or other countries.

MECHANICAL CASE OUTLINE

PACKAGE DIMENSIONS

ON Semiconductor®



SPM5E-023 / 23LD, PDD STD, FULL PACK, DIP TYPE
CASE MODEJ
ISSUE O

DATE 31 JAN 2017

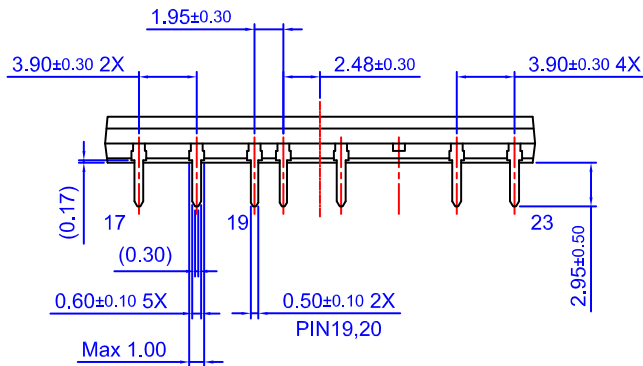
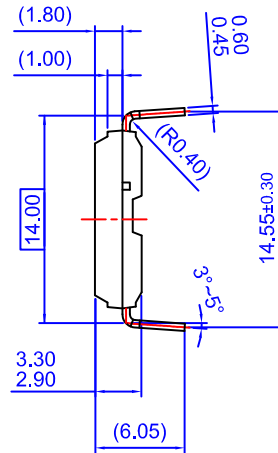
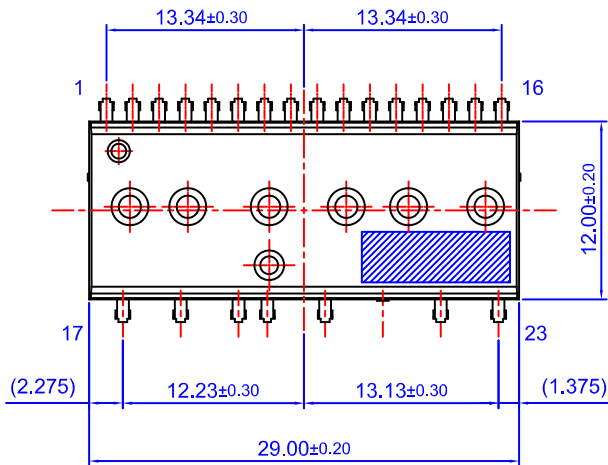
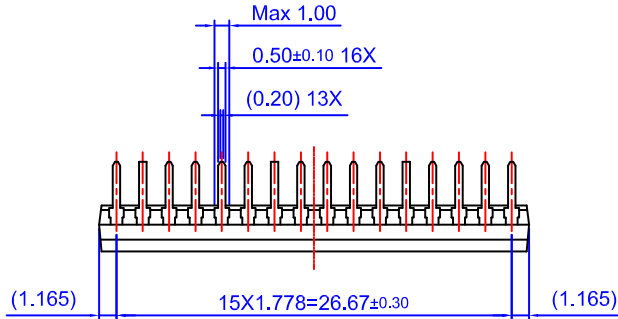

- NOTES: UNLESS OTHERWISE SPECIFIED
- A) THIS PACKAGE DOES NOT COMPLY TO ANY CURRENT PACKAGING STANDARD
 - B) ALL DIMENSIONS ARE IN MILLIMETERS
 - C) DIMENSIONS ARE EXCLUSIVE OF BURRS, MOLD FLASH, AND TIE BAR EXTRUSIONS
 - D) () IS REFERENCE

DOCUMENT NUMBER:	98AON13543G	Electronic versions are uncontrolled except when accessed directly from the Document Repository. Printed versions are uncontrolled except when stamped "CONTROLLED COPY" in red.
DESCRIPTION:	SPM5E-023 / 23LD, PDD STD, FULL PACK, DIP TYPE	PAGE 1 OF 1

ON Semiconductor and are trademarks of Semiconductor Components Industries, LLC dba ON Semiconductor or its subsidiaries in the United States and/or other countries. ON Semiconductor reserves the right to make changes without further notice to any products herein. ON Semiconductor makes no warranty, representation or guarantee regarding the suitability of its products for any particular purpose, nor does ON Semiconductor assume any liability arising out of the application or use of any product or circuit, and specifically disclaims any and all liability, including without limitation special, consequential or incidental damages. ON Semiconductor does not convey any license under its patent rights nor the rights of others.

MECHANICAL CASE OUTLINE

PACKAGE DIMENSIONS

ON Semiconductor®



SPM5H-023 / 23LD, PDD STD, SPM23-BD (Ver1.5) SMD TYPE
CASE MODEM
ISSUE O

DATE 31 JAN 2017

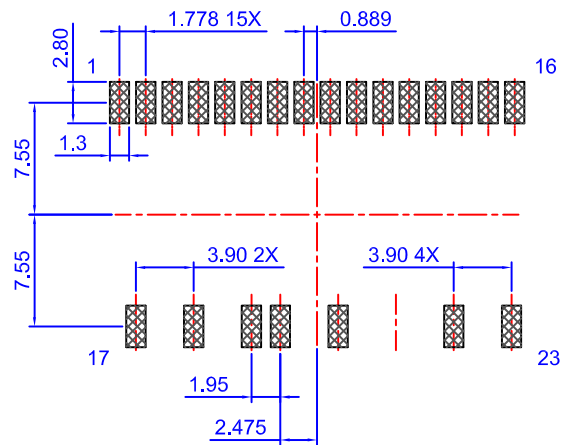
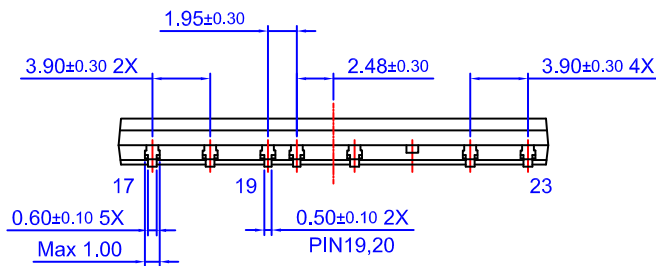
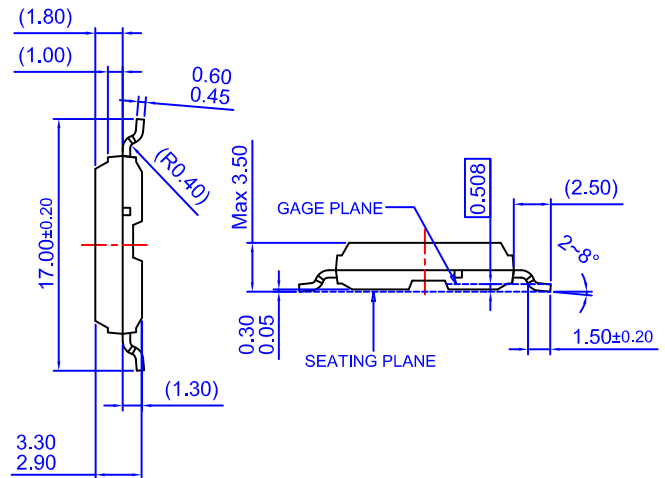
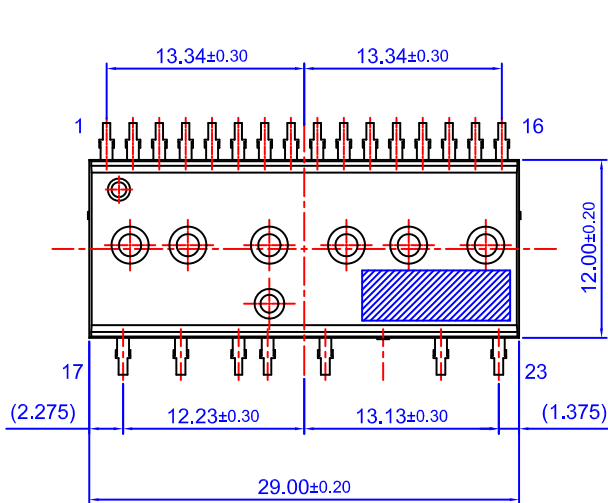
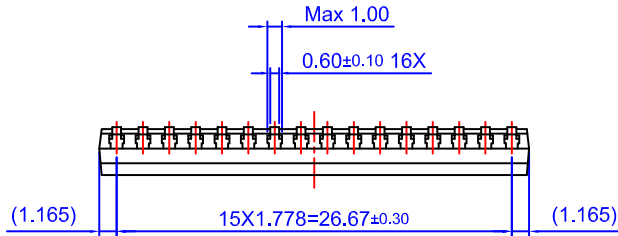

- NOTES: UNLESS OTHERWISE SPECIFIED
 A) THIS PACKAGE DOES NOT COMPLY TO ANY CURRENT PACKAGING STANDARD
 B) ALL DIMENSIONS ARE IN MILLIMETERS
 C) DIMENSIONS ARE EXCLUSIVE OF BURRS, MOLD FLASH, AND TIE BAR EXTRUSIONS
 D) () IS REFERENCE

LAND PATTERN RECOMMENDATIONS

DOCUMENT NUMBER:	98AON13546G	Electronic versions are uncontrolled except when accessed directly from the Document Repository. Printed versions are uncontrolled except when stamped "CONTROLLED COPY" in red.
DESCRIPTION:	SPM5H-023 / 23LD, PDD STD, SPM23-BD (Ver1.5) SMD TYPE	PAGE 1 OF 1

ON Semiconductor and ON are trademarks of Semiconductor Components Industries, LLC dba ON Semiconductor or its subsidiaries in the United States and/or other countries. ON Semiconductor reserves the right to make changes without further notice to any products herein. ON Semiconductor makes no warranty, representation or guarantee regarding the suitability of its products for any particular purpose, nor does ON Semiconductor assume any liability arising out of the application or use of any product or circuit, and specifically disclaims any and all liability, including without limitation special, consequential or incidental damages. ON Semiconductor does not convey any license under its patent rights nor the rights of others.

onsemi, **Onsemi**, and other names, marks, and brands are registered and/or common law trademarks of Semiconductor Components Industries, LLC dba "**onsemi**" or its affiliates and/or subsidiaries in the United States and/or other countries. **onsemi** owns the rights to a number of patents, trademarks, copyrights, trade secrets, and other intellectual property. A listing of **onsemi**'s product/patent coverage may be accessed at www.onsemi.com/site/pdf/Patent-Marking.pdf. **onsemi** reserves the right to make changes at any time to any products or information herein, without notice. The information herein is provided "as-is" and **onsemi** makes no warranty, representation or guarantee regarding the accuracy of the information, product features, availability, functionality, or suitability of its products for any particular purpose, nor does **onsemi** assume any liability arising out of the application or use of any product or circuit, and specifically disclaims any and all liability, including without limitation special, consequential or incidental damages. Buyer is responsible for its products and applications using **onsemi** products, including compliance with all laws, regulations and safety requirements or standards, regardless of any support or applications information provided by **onsemi**. "Typical" parameters which may be provided in **onsemi** data sheets and/or specifications can and do vary in different applications and actual performance may vary over time. All operating parameters, including "Typicals" must be validated for each customer application by customer's technical experts. **onsemi** does not convey any license under any of its intellectual property rights nor the rights of others. **onsemi** products are not designed, intended, or authorized for use as a critical component in life support systems or any FDA Class 3 medical devices or medical devices with a same or similar classification in a foreign jurisdiction or any devices intended for implantation in the human body. Should Buyer purchase or use **onsemi** products for any such unintended or unauthorized application, Buyer shall indemnify and hold **onsemi** and its officers, employees, subsidiaries, affiliates, and distributors harmless against all claims, costs, damages, and expenses, and reasonable attorney fees arising out of, directly or indirectly, any claim of personal injury or death associated with such unintended or unauthorized use, even if such claim alleges that **onsemi** was negligent regarding the design or manufacture of the part. **onsemi** is an Equal Opportunity/Affirmative Action Employer. This literature is subject to all applicable copyright laws and is not for resale in any manner.

ADDITIONAL INFORMATION

TECHNICAL PUBLICATIONS:

Technical Library: www.onsemi.com/design/resources/technical-documentation
onsemi Website: www.onsemi.com

ONLINE SUPPORT: www.onsemi.com/support

For additional information, please contact your local Sales Representative at www.onsemi.com/support/sales

Looking for pricing, stock, or lifecycle information?

Click below to explore more details on WIN SOURCE:

 [View NFA50460R4B on WIN SOURCE](#)

 [ON Semiconductor](#) Information

Optimize Your Supply Chain with WIN SOURCE Solutions

-  Global Sourcing Solution
-  Obsolete Management
-  Cost Control Management
-  Shortage Management
-  Alternative Solution
-  Excess Inventory Management