



THE DATASHEET OF SVM30-J



Datasheet SVM30

Multi-gas, humidity and temperature sensor combo module

- Measures indoor air quality parameters total VOC (tVOC), CO₂-equivalent (CO₂eq), relative humidity RH and temperature T
- Automatic baseline compensation and humidity compensation of MOX gas sensor
- Outstanding long-term stability and reliability
- Fully factory calibrated and tested
- Digital I2C interface
- 5V supply voltage
- Dimensions: 39 x 15 x 6.5 mm

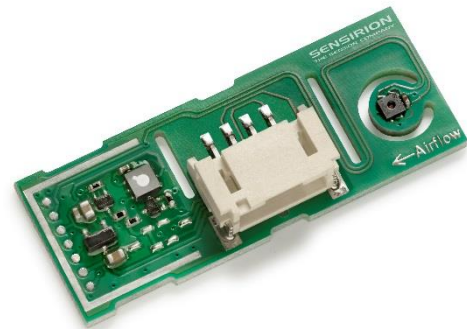

Product Summary

The SVM30 is a Multi-gas, humidity and temperature sensor combo module containing an SGP30 gas sensor as well as an SHTC1 humidity and temperature sensor.

The SGP30 gas sensor on the SVM30 combines multiple metal-oxide sensing elements – the pixels – on one chip, thereby offering the possibility to measure a total VOC signal (tVOC) and a CO₂ equivalent signal (CO₂eq) with one single sensor-chip. The SVM30 further offers calibrated air quality output signals as well as compensation of humidity cross-sensitivity. The sensing element features an unmatched robustness against contamination by siloxanes present in real-world applications enabling a unique long-term stability and low drift.

The humidity and temperature sensor on SVM30 covers a humidity measurement range of 0 to 100 %RH and a temperature measurement range of -20 to 85 °C with a typical accuracy of ±5 %RH and ±1 °C.

The gas and RH/T sensor components are designed with Sensirion's CMOSens® technology. This technology offers a complete sensor system on a single chip, including the sensing elements, analog and digital signal processing, A/D converter, calibration and data memory and a digital communication interface supporting I2C standard mode. Sensirion's state-of-the-art production process, including full calibration and testing of the sensors, guarantees high reproducibility and reliability.

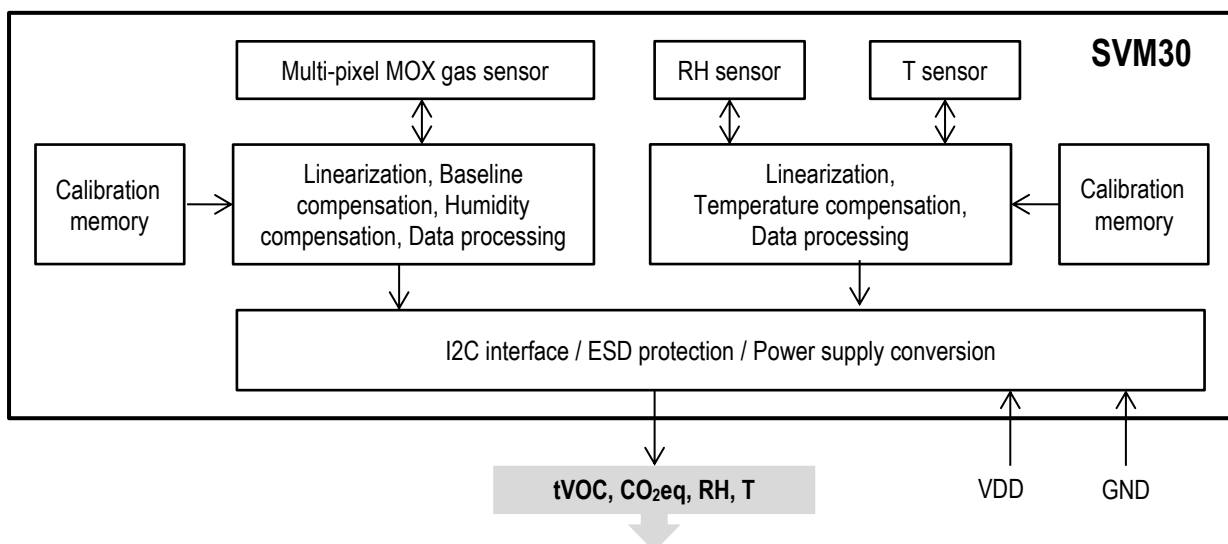

Content

1 Gas, humidity and temperature sensor specification	3
1.1 Gas sensing performance	3
1.2 Air Quality Signals	4
1.3 Relative humidity	5
1.4 Temperature	5
1.5 Recommended operating conditions	5
2 Electrical specification	6
2.1 Electrical characteristics	6
2.2 Absolute maximum ratings	6
3 Timing specification	6
3.1 Sensor system timing	6
4 Mechanical specification	7
4.1 Sensor dimensions and mechanical design	7
4.2 Connector specification and pin assignment	7
5 Interface specification	8
6 Operation	9
6.1 Power-Up and Communication Start	9
6.2 Measurement Communication Sequence	9
6.3 Measurement Commands	11
6.4 Soft Reset	13
6.5 Get Serial ID	13
6.6 Checksum Calculation	14
6.7 Conversion of the sensor output for RH and T	14
7 Application description	15
7.1 Typical application diagram	15
7.2 Mounting recommendations	15
8 Quality	16
9 Ordering Information	16
10 Important notices	17
10.1 Warning, personal injury	17
10.2 ESD precautions	17
10.3 Warranty	17
11 Revision history	18
12 Headquarters and subsidiaries	18

1 Gas, humidity and temperature sensor specification

1.1 Gas sensing performance

The values listed in **Table 1** are valid at 25°C, 50% RH and typical VDD.

Parameter	Signal	Values	Comments
Measurement range ¹	Ethanol signal	0 ppm to 1000 ppm	
	H ₂ signal	0 ppm to 1000 ppm	
Specified measurement range	Ethanol signal	0.3 ppm to 30 ppm	The specifications below are defined for this measurement range ² . The specified measurement range covers the gas concentrations expected in indoor air quality applications.
	H ₂ signal	0.5 ppm to 3 ppm	
Accuracy ^{3,4}	Ethanol signal	see Figure 1 typ.: 15% of meas. value	Accuracy of the concentration <i>c</i> determined by $\ln\left(\frac{c}{c_{ref}}\right) = \frac{(s_{ref} - s_{out})}{a}$ <i>a</i> = 512 <i>s_{out}</i> : EthOH/H ₂ signal output at concentration <i>c</i> <i>s_{ref}</i> : EthOH/H ₂ signal output at 0.5 ppm H ₂
	H ₂ signal	see Figure 2 typ.: 10% of meas. value	
Sensitivity	Ethanol signal	-1.0	Sensitivity <i>n</i> is defined by $\frac{s_{ref} - s_{out}}{512} = -n \cdot \ln\left(\frac{c}{c_{ref}}\right)$ The typical numerical value of <i>n</i> is <i>n</i> = -1 for both, the Ethanol and H ₂ signal. The sensitivity is understood as an average value over the specified measurement range as determined by a least square fit.
	H ₂ signal	-1.0	
Sensitivity tolerance ³	Ethanol signal	typ. tolerance: ±7% rel. error max. tolerance: ±14% rel. error	
	H ₂ signal	typ. tolerance: ±7% rel. error max. tolerance: ±14% rel. error	
Long-term drift ^{3,5}	Ethanol signal	see Figure 3 typ.: 1.3% of meas. value	Change of accuracy over time: Siloxane accelerated lifetime test ⁶
	H ₂ signal	see Figure 4 typ.: 1.3% of meas. value	
Resolution	Ethanol signal	0.2 % of meas. value	Resolution of Ethanol and H ₂ signal outputs in relative change of the measured concentration
	H ₂ signal		
Sampling frequency	Ethanol signal	Max. 40 Hz	Compare with minimum measurement duration in Table 13
	H ₂ signal		

Table 1 Gas sensing performance.

¹ Exposure to ethanol and H₂ concentrations up to 1000 ppm have been tested. For applications requiring the measurement of higher gas concentrations please contact Sensirion.

² ppm: parts per million. 1 ppm = 1000 ppb (parts per billion)

³ 90% of the sensors will be within the typical accuracy tolerance, >99% are within the maximum tolerance.

⁴ Valid at an air flow of > 1m/s.

⁵ The long-term drift is stated as change of accuracy per year of operation.

⁶ Test conditions: operation in 250 ppm Decamethylcyclotetrasiloxane (D5) for 200h simulating 10 years of operation in an indoor environment.

Accuracy ethanol signal

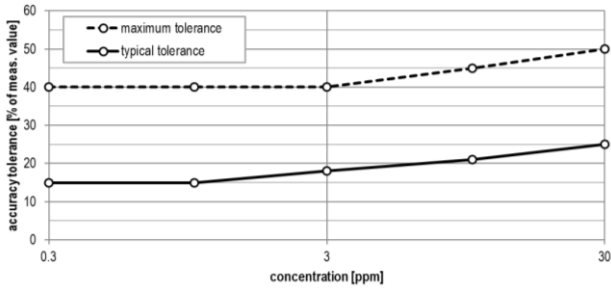

Figure 1 Typical and maximum accuracy tolerance in % of measured value at 25°C, 50% RH and typical VDD. The sensors have been operated for at least 24h before the characterization.

Accuracy H₂ signal

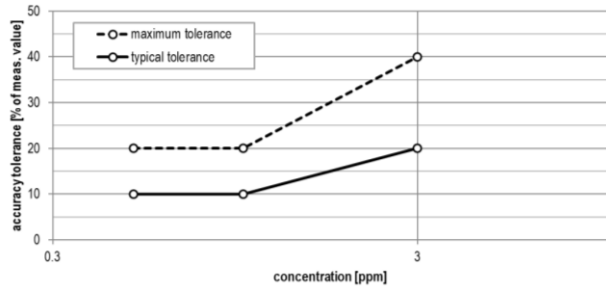

Figure 2 Typical and maximum accuracy tolerance in % of measured value at 25°C, 50% RH and typical VDD. The sensors have been operated for at least 60h before the characterization.

Long-term drift Ethanol signal

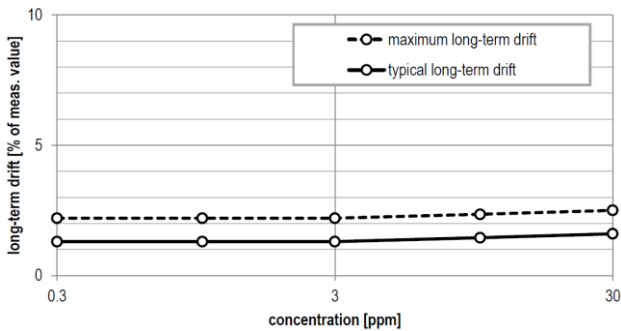

Figure 3 Typical and maximum long-term drift in % of measured value at 25°C, 50% RH and typical VDD. The sensors have been operated for at least 24h before the first characterization.

Long-term drift H₂ signal

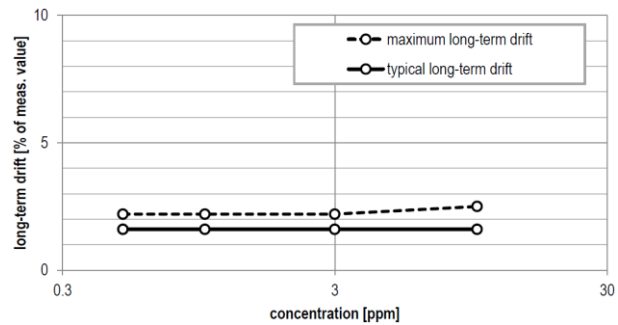

Figure 4 Typical and maximum long-term drift in % of measured value at 25°C, 50% RH and typical VDD. The sensors have been operated for at least 60h before the first characterization.

1.2 Air Quality Signals

Parameter	Signal	Value	Comments
Output range	TVOC signal	0 ppb to 60000 ppb	Maximum possible output range. The gas sensing performance is specified for the measurement range as defined in Table 1
	CO ₂ eq signal	400 ppm to 60000 ppm	
Resolution	TVOC signal	0 ppb - 2008 ppb	1 ppb
		2008 ppb – 11110 ppb	6 ppb
		11110 ppb – 60000 ppb	32 ppb
	CO ₂ eq signal	400 ppm – 1479 ppm	1 ppm
		1479 ppm – 5144 ppm	3 ppm
		5144 ppm – 17597 ppm	9 ppm
		17597 ppm – 60000 ppm	31 ppm
Sampling rate	TVOC signal	1 Hz	The on-chip baseline compensation algorithm has been optimized for this sampling rate. The sensor shows best performance when used with this sampling rate.
	CO ₂ eq signal	1 Hz	

Table 2 Air quality signal specification

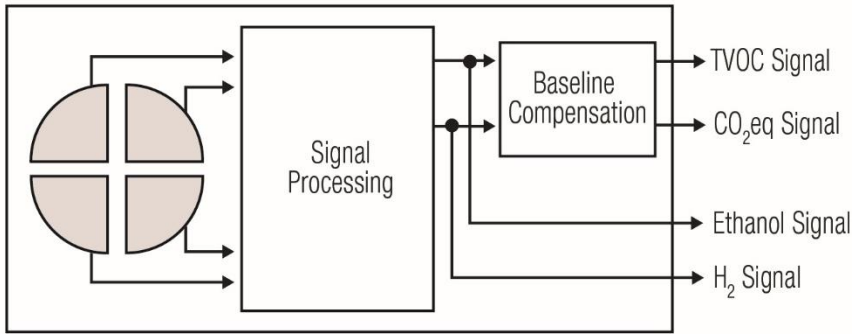

Figure 5 Simplified version of the functional block diagram showing the signal paths of the gas sensor SGP30.

1.3 Relative humidity

Parameter	Conditions	Value	Units
Accuracy tolerance ⁷	In range of 25 ... 75 %RH and 5 ... 55 °C	±5.0	%RH
Repeatability ⁸	-	0.1	%RH
Resolution ⁹	-	0.01	%RH
Hysteresis	-	±1	%RH
Operating range	non-condensing environment ¹⁰	0 ... 100	%RH
Response time ¹¹	τ 63%	8	s
Long-term drift ¹²	Typ.	<0.25	%RH/y

Table 3: Humidity sensor specification

1.4 Temperature

Parameter	Conditions	Value	Units
Accuracy tolerance ⁷	In range of 5 ... 55 °C	±1	°C
Repeatability ⁸	-	0.1	°C
Resolution ⁹	-	0.01	°C
Operating range	-	-20 ... +85	°C
Long-term drift ¹³	Typ.	<0.02	°C/y

Table 4: Temperature sensor specification

1.5 Recommended operating conditions

The sensors show best performance when operated within recommended normal temperature range of 5...55°C and absolute humidity range of 4...20 g/m³. Long-term exposure (operated and not operated) to conditions outside the recommended range, especially at high humidity, may affect the sensor performance. Prolonged exposure to extreme conditions may accelerate aging. Furthermore, it may temporarily offset the RH signal (e.g. +3%RH after 60h at >80%RH). After returning into the normal temperature and humidity range the RH-sensor will slowly come back to calibration state by itself. To ensure stable operation of the gas sensor, the conditions described in the document *SGP Handling and Assembly Instructions* as well as the *Infosheet Handling*

⁷ Typical accuracy tolerance according to the document "Sensirion Humidity Sensor Specification Statement". Valid for an air flow of > 1 m/s.

⁸ The stated repeatability is 3 times the standard deviation (3 σ) of multiple consecutive measurement values at constant conditions and is a measure for the noise on the physical sensor output.

⁹ Resolution of A/D converter.

¹⁰ Condensation shall be avoided because of risk of corrosion and leak currents on the PCB.

¹¹ Time for achieving 63% of a humidity step function, valid at 25°C and 1 m/s airflow. Humidity response time in the application depends on the design-in of the sensor.

¹² Typical value for operation in normal RH/T operating range. Max. value is < 0.5 %RH/y. Value may be higher in environments with vaporized solvents, out-gassing tapes, adhesives, packaging materials, etc. For more details, please refer to Handling Instructions.

¹³ Max. value is < 0.04°C/y.

Instructions Humidity Sensors regarding exposure to exceptionally high concentrations of some organic or inorganic compounds have to be met, particularly during operation.

2 Electrical specification

2.1 Electrical characteristics

Default conditions of 25 °C and 5 V supply voltage apply to values in the table below, unless otherwise stated.

Parameter	Symbol	Conditions	Min	Typ.	Max	Units	Comments
Supply voltage	V _{DD}		4.5	5	5.5	V	-
Supply current ¹⁴	I _{DD}	Average	-	49		mA	-
Low level input voltage	V _{IL}	-	-0.5		0.4	V	-
High level input voltage	V _{IH}	-	0.7 V _{DD}		V _{DD(max)} + 0.5	V	-
Low level output voltage	V _{OL}	1.5 mA sink current	-	-	0.4	V	-
SDA/SCL load capacitance	C _L			155	200	pF	

Table 5: Electrical specifications

2.2 Absolute maximum ratings

Stress levels beyond those listed in Table 6 may cause permanent damage to the device. These are stress ratings only and functional operation of the device at these conditions cannot be guaranteed. Exposure to the absolute maximum rating conditions for extended periods may affect the reliability of the device. ESD ratings are for discharge on pins according to IEC 61000-4-2, part 4-2.

Parameter	Rating
Supply voltage, V _{DD}	-0.3 ... +6.5 V
Maximum voltage level at pins SCL, SDA	-0.3 ... +6.5 V
Operating temperature range	-20 ... +85 °C
Storage temperature range ¹⁵	-40 ... +85 °C
ESD HBM	8 kV
ESD MM	200 V

Table 6: Absolute maximum ratings.

3 Timing specification

3.1 Sensor system timing

Default conditions of 25 °C and 5 V supply voltage apply to values the table below, unless otherwise stated.

Parameter	Symbol	Conditions	Min.	Typ.	Max.	Units	Comments
Power-up time	t _{PU}	After hard reset	-	0.4	0.6	ms	Time between power-up and sensor entering idle state
Measurement duration RH/T sensor	t _{MEAS}	-	-	10.8	14.4	ms	Duration for a humidity and temperature measurement
Measurement duration gas sensor	See Table 13						

Table 7: Sensor timing specifications.

¹⁴ A 20% higher current is drawn during 5ms on VDDH after entering the measurement mode of the gas sensor.

¹⁵ The recommended storage temperature range is 10-50°C. Please consult the *Infosheet Handling Instructions Humidity Sensors* for more information.

4 Mechanical specification

4.1 Sensor dimensions and mechanical design

The physical dimension of SMV30 are shown in **Figure 6** and **Table 8**.

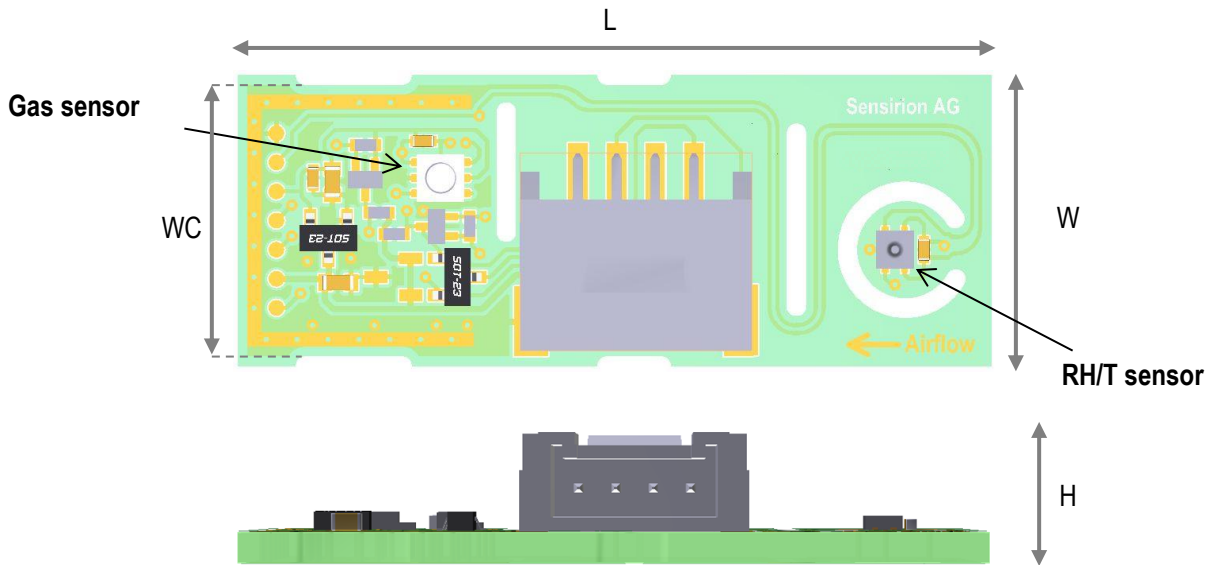

Figure 6 Top and front view of SVM30

Parameter	Symbol	Max.	Units	Comment
Length	L	39	mm	-
Width	W	15	mm	-
Width at constriction	WC	14	mm	-
Height	H	6.5	mm	For product version SVM30-Y
		7.2	mm	For product version SVM30-J

Table 8 Mechanical dimensions

4.2 Connector specification and pin assignment

The pin assignment is shown in **Table 9**.

Pin	Name	Comment
1	SCL	I2C serial clock input
2	GND	Ground (negative supply)
3	VDD	Power supply (positive supply)
4	SDA	I2C serial data input / output

Table 9 Pin assignment

SVM30 can be delivered with the connectors listed in **Table 10**.

Product Version	Connector type
SVM30-Y	Yeonho Electronics, 20037WR-04
SVM30-J	Scondar SCT2001WR -S-4P (compatible to JST part no. S4B-PH-SM4-TB)

Table 10 Available connector types

5 Interface specification

Default conditions of 25 °C and 5 V supply voltage apply to the timing of the I2C interface specified in **Table 11** and **Figure 7**.

Parameter	Symbol	Conditions	Min.	Typ.	Max.	Units
SCL clock frequency	f_{SCL}	-	0	-	100	kHz
Hold time (repeated) START condition	$t_{HD,STA}$	After this period, the first clock pulse is generated	4.0	-	-	μs
LOW period of the SCL clock	t_{LOW}	-	4.7	-	-	μs
HIGH period of the SCL clock	t_{HIGH}	-	4.0	-	-	μs
Set-up time for a repeated START condition	$t_{SU,STA}$	-	4.7	-	-	μs
SDA hold time	$t_{HD,DAT}$	-	0	-	-	ns
SDA set-up time	$t_{SU,DAT}$	-	250	-	-	ns
SCL/SDA rise time	t_R	-	-	-	1000	ns
SCL/SDA fall time	t_F	-	-	-	300	ns
SDA valid time	$t_{VD,DAT}$	-	-	-	3.45	μs
Set-up time for STOP condition	$t_{SU,STO}$	-	4.0	-	-	μs
Capacitive load on bus line	C_B	-			400	pF

Table 11 Communication timing specification

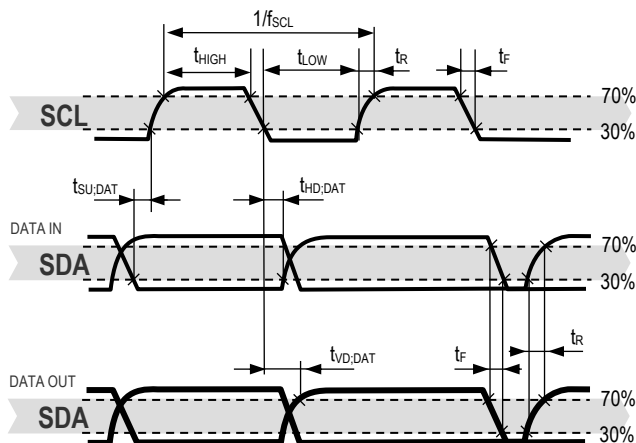

Figure 7 Timing diagram for digital input/output pads. SDA in / out as seen by SVM30. Bold SDA lines are controlled by the sensor; plain SDA lines are controlled by the micro-controller. Note that SDA valid read time is triggered by falling edge of preceding bit.

6 Operation

The SVM30 supports I²C standard mode. For detailed information on the I²C protocol, refer to NXP I²C-bus specification. All commands and data are mapped to a 16-bit address space. Additionally, data and commands are protected with a CRC checksum to increase the communication reliability. The 16-bit commands that are sent to the sensor already include a 3-bit CRC checksum. Data sent from and received by SVM30 is always succeeded by an 8-bit CRC.

In write direction it is mandatory to transmit the checksum, since SVM30 only accepts data if it is followed by the correct checksum. In read direction it is up to the master to decide if it wants to read and process the checksum.

The device addresses of the two sensors on SVM30 are listed in **Table 12**.

Sensor	Hex. Code
SGP30	0x58
SHTC1	0x70

Table 12 I²C device addresses of the sensors on SVM30

The typical communication sequence between the I²C master (e.g., a microcontroller in a host device) and the sensor is described as follows:

1. The sensor is powered up, communication is initialized
2. The I²C master periodically requests measurement and reads data, in the following sequence:
 - a. I²C master sends a measurement command
 - b. I²C master waits until the measurement is finished, either by waiting for the maximum execution time or by waiting for the expected duration and then poll data until the read header is acknowledged by the sensor (expected durations are listed in **Table 13** and **Table 7**)
 - c. I²C master reads out the measurement result

6.1 Power-Up and Communication Start

After the supply voltage reaching its specified range (see **Table 5**) the sensor needs the time t_{PU} (see **Table 7**) to enter the idle state. Once the idle state is entered it is ready to receive commands from the master.

Each transmission sequence begins with a START condition (S) and ends with a STOP condition (P) as described in the I²C-bus specification.

Please note that in case VDD is set to 0 V (GND), e.g. in case of a power off of SVM30, the SCL and SDA pads are also pulled to GND. Consequently, the I²C bus is blocked while VDD of SVM30 is set to 0 V.

6.2 Measurement Communication Sequence

A measurement communication sequence consists of a START condition, the I²C write header (7-bit I²C device address plus 0 as the write bit) and a 16-bit measurement command (see **Figure 8**). The proper reception of each byte is indicated by the sensor. It pulls the SDA pin low (ACK bit) after the falling edge of the 8th SCL clock to indicate the reception. With the acknowledgement of the measurement command, SVM30 starts measuring. When the measurement is in progress, no communication with the sensor is possible and the sensor aborts the communication with a XCK condition.

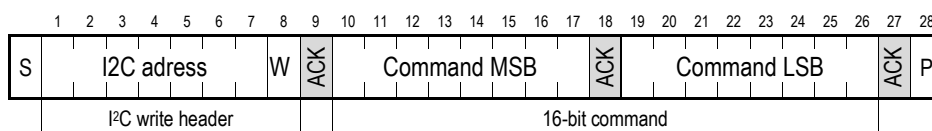

Figure 8 Command access communication sequence.

After the sensor has completed the measurement, the master can read the measurement results by sending a START condition followed by an I²C read header. The sensor will acknowledge the reception of the read header and responds with data. The response data length is listed in **Table 13** for SGP30, the one of SHTC1 is 6 bytes incl. checksum. The response data is structured in data words, where one word consists of two bytes of data followed by one byte CRC checksum. Each byte must be acknowledged by the microcontroller with an ACK condition for the sensor to continue sending data. If the sensor does not receive an ACK from the master after any byte of data, it will not continue sending data. After receiving the checksum for the last word of data, an XCK and STOP condition has to be sent.

The communication data sequences are shown in **Figure 9** for SGP30 and in **Figure 10** for SHTC1.

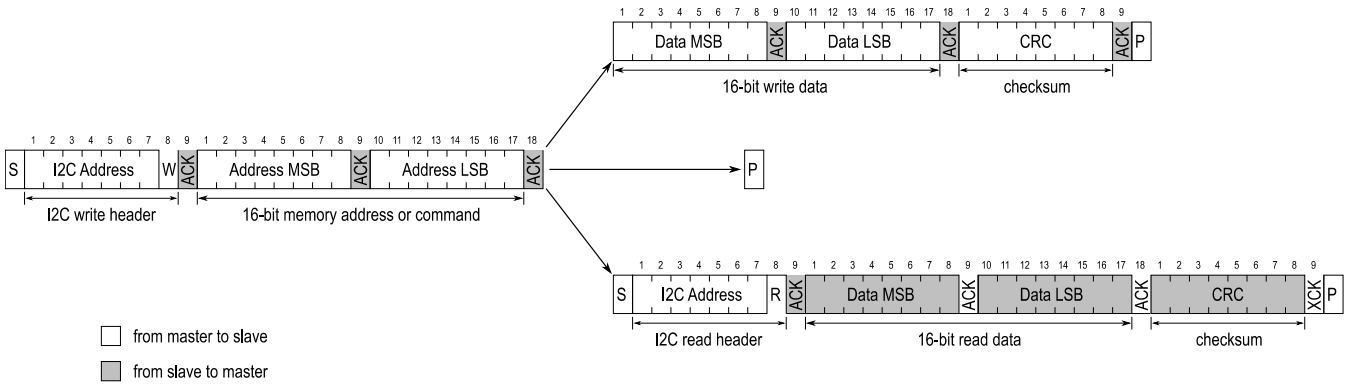

Figure 9 Communication sequence for starting a measurement and reading measurement results of SGP30.

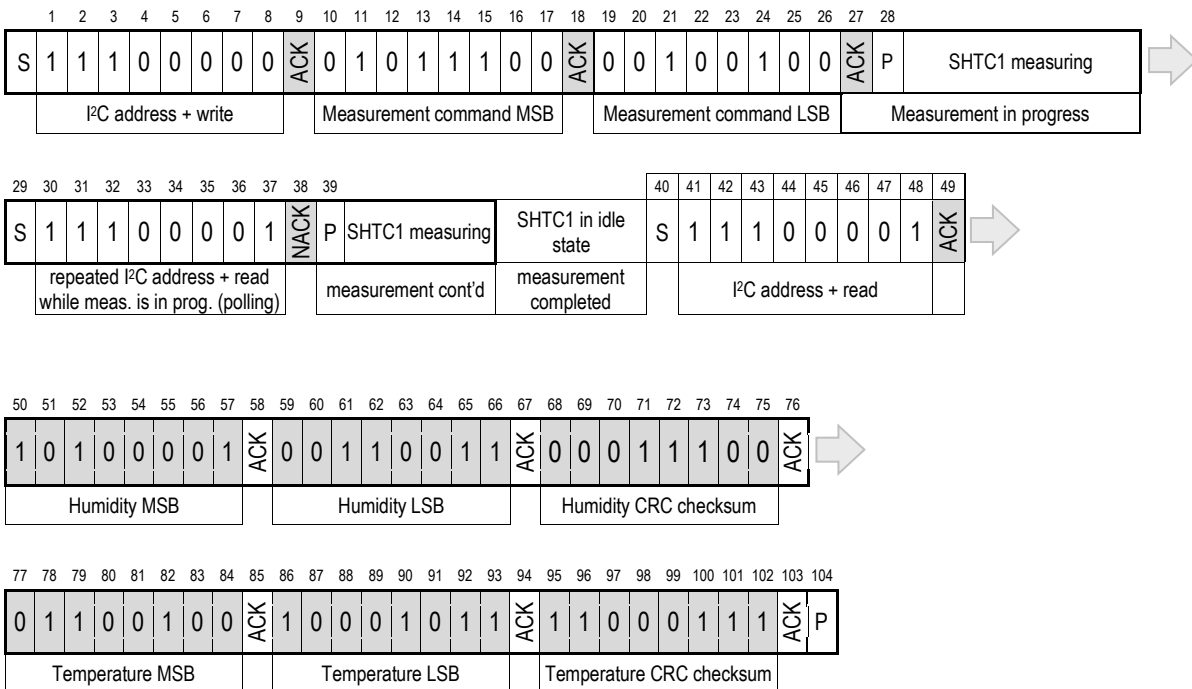

Figure 10 Communication sequence for starting a measurement and reading measurement results of SHTC1. The numerical example corresponds to a read humidity-first command with clock stretching enabled. The physical values of the transmitted measurement results are 62.9 %RH and 23.7 °C. Clear blocks are controlled by the microcontroller, grey blocks by SHTC1.

The I²C master can abort the read transfer with a XCK followed by a STOP condition after any data byte if it is not interested in subsequent data, e.g. the CRC byte or following data bytes, in order to save time. Note that the data cannot be read more than once, and access to data beyond the specified amount will return a pattern of 1's.

6.3 Measurement Commands

The available measurement commands of SGP30 are listed in **Table 13** and the ones of SHTC1 in **Table 14**.

Feature Set	0x0020				
Command	Hex. Code	Parameter length including CRC [bytes]	Response length including CRC [bytes]	Measurement duration [ms]	
				Typ.	Max.
Init_air_quality	0x2003	-	-	2	10
Measure_air_quality	0x2008	-	6	10	12
Get_baseline	0x2015	-	6	10	10
Set_baseline	0x201e	6	-	10	10
Set_humidity	0x2061	3	-	1	10
Measure_test ¹⁶	0x2032	-	3	200	220
Get_feature_set_version	0x202f	-	3	1	2
Measure_raw_signals	0x2050	-	6	20	25

Table 13 Measurement commands of SGP30

Read T first	Read RH first
0x7866	0x58E0

Table 14 Measurement commands of SHTC1

SGP30 Air Quality Signals

SGP30 uses a dynamic baseline compensation algorithm and on-chip calibration parameters to provide two complementary air quality signals. Based on the sensor signals a total VOC signal (TVOC) and a CO₂ equivalent signal (CO₂eq) are calculated. Sending an “Init_air_quality” command starts the air quality measurement. After the “Init_air_quality” command, a “Measure_air_quality” command has to be sent in regular intervals of 1s to ensure proper operation of the dynamic baseline compensation algorithm. The sensor responds with 2 data bytes (MSB first) and 1 CRC byte for each of the two preprocessed air quality signals in the order CO₂eq (ppm) and TVOC (ppb). For the first 15s after the “Init_air_quality” command the sensor is in an initialization phase during which a “Measure_air_quality” command returns fixed values of 400 ppm CO₂eq and 0 ppb TVOC.

A new “Init_air_quality” command has to be sent after every power-up or soft reset.

SGP30 Set and Get Baseline

The SGP30 also provides the possibility to read and write the baseline values of the baseline compensation algorithm. This feature is used to save the baseline in regular intervals on an external non-volatile memory and restore it after a new power-up or soft reset of the sensor. The command “Get_baseline” returns the baseline values for the two air quality signals. The sensor responds with 2 data bytes (MSB first) and 1 CRC byte for each of the two values in the order CO₂eq and TVOC. These two values should be stored on an external memory. After a power-up or soft reset, the baseline of the baseline compensation algorithm can be restored by sending first an “Init_air_quality” command followed by a “Set_baseline” command with the two baseline values as parameters in the order as (TVOC, CO₂eq). An example implementation of a generic driver for the baseline algorithm can be found in the document *SGP30_driver_integration_guide*.

SGP30 Raw Signals

The command “Measure_raw_signals” is intended for part verification and testing purposes. It returns the sensor raw signals which are used as inputs for the on-chip calibration and baseline compensation algorithms as shown in **Figure 5**. The command performs a measurement to which the sensor responds with 2 data bytes (MSB first) and 1 CRC byte

¹⁶ The «Measure_Test» command is intended for production line testing and verification only. It should not be used after having issued an “Init_air_quality” command. For the duration of the «Measure_Test» command, the sensor is operated in measurement mode with a supply current as specified in **Table 5**. After the command, the sensor is in sleep mode.

(see **Figure 9**) for 2 sensor raw signals in the order H2_signal (s_{out_H2}) and Ethanol_signal (s_{out_EthOH}). Both signals can be used to calculate gas concentrations c relative to a reference concentration c_{ref} by

$$\ln\left(\frac{c}{c_{ref}}\right) = \frac{s_{ref} - s_{out}}{a}$$

with $a = 512$, s_{ref} the H2_signal or Ethanol_signal output at the reference concentration, and $s_{out} = s_{out_H2}$

or $s_{out} = s_{out_EthOH}$.

SGP30 Humidity Compensation

SGP30 features an on-chip humidity compensation for the air quality signals (CO₂eq and TVOC) and sensor raw signals (H2-signal and Ethanol_signal). To use the on-chip humidity compensation an absolute humidity value from an external humidity sensor like the SHTxx is required. Using the “Set_humidity” command, a new humidity value can be written to the SGP30 by sending 2 data bytes (MSB first) and 1 CRC byte. The 2 data bytes represent humidity values as a fixed-point 8.8bit number with a minimum value of 0x0001 (=1/256 g/m³) and a maximum value of 0xFFFF (255 g/m³ + 255/256 g/m³). For instance, sending a value of 0x0F80 corresponds to a humidity value of 15.50 g/m³ (15 g/m³ + 128/256 g/m³).

After setting a new humidity value, this value will be used by the on-chip humidity compensation algorithm until a new humidity value is set using the “Set_humidity” command. Restarting the sensor (power-on or soft reset) or sending a value of 0x0000 (= 0 g/m³) sets the humidity value used for compensation to its default value (0x0B92 = 11.57 g/m³) until a new humidity value is sent. Sending a humidity value of 0x0000 can therefore be used to turn off the humidity compensation.

SGP30 Feature Set

SGP30 features a versioning system for the available set of measurement commands and on-chip algorithms. This so called feature set version number can be read out by sending a “Get_feature_set_version” command. The sensor responds with 2 data bytes (MSB first) and 1 CRC byte (see **Table 15**). This feature set version number is used to refer to a corresponding set of available measurement commands as listed in **Table 13**.

Most significant byte (MSB)								Least significant byte (LSB)								
Bit	1	2	3	4	5	6	7	8	9	10	11	12	13	14	15	16
	Product type SGP30: 0				Reserved for future use			0	Product version							

Table 15 Structure of the SGP feature set number. Please note that the last 5 bits of the product version (bits 12-16 of the LSB) are subject to change. This is used to track new features added to the SGP multi-pixel platform.

SGP30 Measure Test

The command “Measure_test” which is included for integration and production line testing runs an on-chip self-test. In case of a successful self-test the sensor returns the fixed data pattern 0xD400 (with correct CRC).

6.4 Soft Reset

SGP30

A sensor reset can be generated using the “General Call” mode according to I²C-bus specification. It is important to understand that a reset generated in this way is not device specific. All devices on the same I²C bus that support the General Call mode will perform a reset. The appropriate command consists of two bytes and is shown in **Table 16**.

Command	Hex. Code
Address byte	0x00
Second byte	0x06
Reset Command using the General Call address	0x0006

Table 16 Reset of SGP30 through the General Call address (Clear blocks are controlled by the microcontroller, grey blocks by the sensor.).

SHTC1

SHTC1 provides a soft reset mechanism that forces the system into a well-defined state without removing the power supply. If the system is in idle state (i.e. if no measurement is in progress) the soft reset command can be sent to SHTC1 according to Figure 8. This triggers the sensor to reset all internal state machines and reload calibration data from the memory.

Command	Hex. Code	Bin. Code
Software reset	0x805D	1000'0000'0101'1101

Table 17 Soft reset command for SHTC1

6.5 Get Serial ID

SGP30

The readout of the serial ID register can be used to identify the chip and verify the presence of the sensor. The appropriate command structure is shown in **Table 18**. After issuing the measurement command and sending the ACK-bit the sensor needs the time $t_{DLE} = 0.5\text{ms}$ to respond to the I²C read header with an ACK Bit. Hence, it is recommended to wait $t_{DLE} = 0.5\text{ms}$ before issuing the read header.

The get serial ID command returns 3 words, and every word is followed by an 8-bit CRC checksum. Together the 3 words constitute a unique serial ID with a length of 48 bits.

The ID returned with this command are represented in the big endian (or MSB first) format.

Command	Hex. Code
Read ID register	0x3682

Table 18 Get serial ID command of SGP30

SHTC1

SHTC1 has an ID register which contains an SHTC1-specific product code. The read-out of the ID register can be used to verify the presence of the sensor and proper communication. The command to read the ID register is shown in Table 19.

Command	Hex. Code
Read ID register	0xEFC8

Table 19 Get serial ID command of SHTC1

It needs to be sent to the SHTC1 after an I²C write header. After the SHTC1 has acknowledged the proper reception of the command, the master can send an I²C read header and the SHTC1 will submit the 16-bit ID followed by 8 bits of CRC. The structure of the ID is described in Table 20.

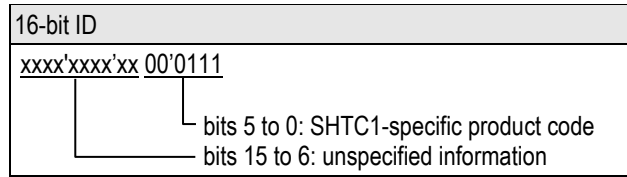

Table 20 Structure of the 16-bit ID of SHTC1. Bits 15:6 of the ID contain unspecified information (marked as “x”), which may vary from sensor to sensor, while bits 5:0 contain the SHTC1-specific product code.

6.6 Checksum Calculation

The 8-bit CRC checksum transmitted after each data word is generated by a CRC algorithm. Its properties are displayed in **Table 21**. The CRC covers the contents of the two previously transmitted data bytes. To calculate the checksum only these two previously transmitted data bytes are used.

Property	Value
Name	CRC-8
Width	8 bit
Protected Data	read and/or write data
Polynomial	0x31 (x ⁸ + x ⁵ + x ⁴ + 1)
Initialization	0xFF
Reflect input	False
Reflect output	False
Final XOR	0x00
Examples	CRC (0xBEEF) = 0x92

Table 21 I²C CRC properties.

6.7 Conversion of the sensor output for RH and T

Measurement data is always transferred as 16-bit values. These values are already linearized and temperature compensated by SHTC1. Humidity and temperature values can be calculated with the formulae given below.

Temperature conversion formula (result in °C)

$$T = -45.68 + 175.7 * \frac{S_T}{2^{16}}$$

Relative humidity conversion formula (result in %RH)

$$RH = \left(103.7 - 3.2 * \frac{S_T}{2^{16}} \right) * \frac{S_{RH}}{2^{16}}$$

S_{RH} and S_T denote the 16-bit sensor outputs (as decimal values) for relative humidity and temperature, respectively.

7 Application description

7.1 Typical application diagram

A typical application diagram is shown in **Figure 11**. Because SVM30 already contains pull-up resistors on the I2C lines, the two resistors shown in the typical application diagram are optional.

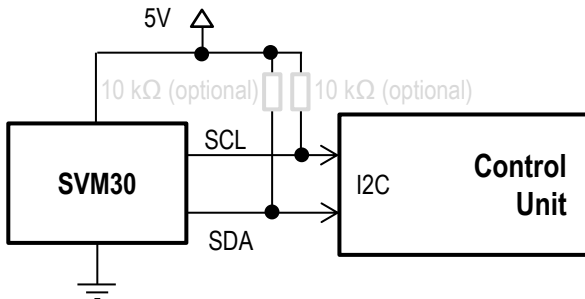

Figure 11 Typical application diagram of SVM30

7.2 Mounting recommendations

In order to maintain a good contact of the sensors to the environment, it is recommended to mount the module in a place where the sensors have good access to ambient air, if possible in direct airflow. In case there is a fan, it is recommended to mount the module in front of the fan and not behind it, in order to avoid the sensors from measuring the heat generated by the fan. To guarantee best performance of the module it is recommended to obey the air flow directions across the module as depicted by the green and red arrows in **Figure 12**.

In case the module is not placed in an airflow, it is recommended to mount the module such that the RH/T sensor is below the gas sensor in order to avoid heating of the RH/T sensor by the gas sensor through convection. Experiments have shown that heat dissipation from the gas sensor is better if the PCB is mounted upright, rather than when it is mounted flat. To reduce thermal coupling through the substrate the module is mounted on, the substrate should end close to the connector, not reaching the RH/T sensor.

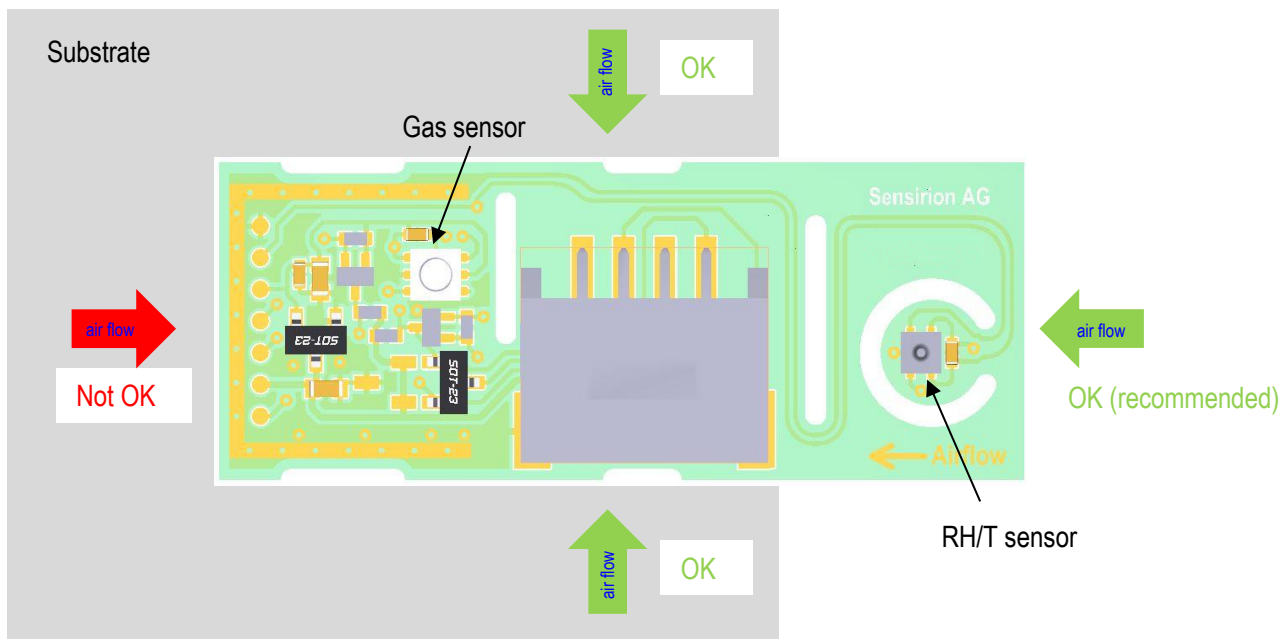

Figure 12 Recommended direction of incident airflow across the module

8 Quality

The qualification of both SGP30 and SHTC1 is performed based on the JEDEC JESD47 qualification test method. Additionally, a separate qualification was performed with the SVM30 module.

Visual optical acceptance criteria of the PCB are according to IPC-A-610, class II.

9 Ordering Information

The SVM30 can be delivered in 2 versions with different connector types (see Table 10). Ordering numbers see Table 22.

Product Version	Ordering Number
SVM30-J 800 PCS	3.000.072
SVM30-J 80 PCS	3.000.237
SVM30-Y 800 PCS	3.000.073
SVM30-Y 80 PCS	3.000.238

Table 22 Ordering numbers.

10 Important notices

10.1 Warning, personal injury

Do not use this product as safety or emergency stop devices or in any other application where failure of the product could result in personal injury. Do not use this product for applications other than its intended and authorized use. Before installing, handling, using or servicing this product, please consult the data sheet and application notes. Failure to comply with these instructions could result in death or serious injury.

If the Buyer shall purchase or use SENSIRION products for any unintended or unauthorized application, Buyer shall defend, indemnify and hold harmless SENSIRION and its officers, employees, subsidiaries, affiliates and distributors against all claims, costs, damages and expenses, and reasonable attorney fees arising out of, directly or indirectly, any claim of personal injury or death associated with such unintended or unauthorized use, even if SENSIRION shall be allegedly negligent with respect to the design or the manufacture of the product.

10.2 ESD precautions

The inherent design of this component causes it to be sensitive to electrostatic discharge (ESD). To prevent ESD-induced damage and/or degradation, take customary and statutory ESD precautions when handling this product. See application note "ESD, Latchup and EMC" for more information.

10.3 Warranty

SENSIRION warrants solely to the original purchaser of this product for a period of 12 months (one year) from the date of delivery that this product shall be of the quality, material and workmanship defined in SENSIRION's published specifications of the product. Within such period, if proven to be defective, SENSIRION shall repair and/or replace this product, in SENSIRION's discretion, free of charge to the Buyer, provided that:

- notice in writing describing the defects shall be given to SENSIRION within fourteen (14) days after their appearance;
- such defects shall be found, to SENSIRION's reasonable satisfaction, to have arisen from SENSIRION's faulty design, material, or workmanship;
- the defective product shall be returned to SENSIRION's factory at the Buyer's expense; and
- the warranty period for any repaired or replaced product shall be limited to the unexpired portion of the original period.

This warranty does not apply to any equipment which has not been installed and used within the specifications recommended by SENSIRION for the intended and proper use of the equipment. EXCEPT FOR THE WARRANTIES EXPRESSLY SET FORTH HEREIN, SENSIRION MAKES NO WARRANTIES, EITHER EXPRESS OR IMPLIED, WITH RESPECT TO THE PRODUCT. ANY AND ALL WARRANTIES, INCLUDING WITHOUT LIMITATION, WARRANTIES OF MERCHANTABILITY OR FITNESS FOR A PARTICULAR PURPOSE, ARE EXPRESSLY EXCLUDED AND DECLINED.

SENSIRION is only liable for defects of this product arising under the conditions of operation provided for in the data sheet and proper use of the goods. SENSIRION explicitly disclaims all warranties, express or implied, for any period during which the goods are operated or stored not in accordance with the technical specifications.

SENSIRION does not assume any liability arising out of any application or use of any product or circuit and specifically disclaims any and all liability, including without limitation consequential or incidental damages. All operating parameters, including without limitation recommended parameters, must be validated for each customer's applications by customer's technical experts. Recommended parameters can and do vary in different applications.

SENSIRION reserves the right, without further notice, (i) to change the product specifications and/or the information in this document and (ii) to improve reliability, functions and design of this product.

Copyright© 2018, by SENSIRION.
CMOSens® is a trademark of Sensirion
All rights reserved

11 Revision history

Date	Version	Page(s)	Changes
13. July 2018	1	all	Initial Release
01. March 2019	1.1	16	Added order numbers for 80 PCS package

12 Headquarters and subsidiaries

Sensirion AG

Laubisruetistr. 50
CH-8712 Staefa ZH
Switzerland

phone: +41 44 306 40 00
fax: +41 44 306 40 30
info@sensirion.com
www.sensirion.com

Sensirion Taiwan Co. Ltd

phone: +886 3 5506701
info@sensirion.com
www.sensirion.com

Sensirion Inc., USA

phone: +1 312 690 5858
info-us@sensirion.com
www.sensirion.com

Sensirion Japan Co. Ltd.

phone: +81 3 3444 4940
info-jp@sensirion.com
www.sensirion.co.jp

Sensirion Korea Co. Ltd.

phone: +82 31 337 7700~3
info-kr@sensirion.com
www.sensirion.co.kr



Sensirion China Co. Ltd.

phone: +86 755 8252 1501
info-cn@sensirion.com
www.sensirion.com.cn

To find your local representative, please visit www.sensirion.com/distributors

Looking for pricing, stock, or lifecycle information?

Click below to explore more details on WIN SOURCE:

-  [View SVM30-J on WIN SOURCE](#)
-  [Sensirion AG Information](#)

Optimize Your Supply Chain with WIN SOURCE Solutions

-  Global Sourcing Solution
-  Obsolete Management
-  Cost Control Management
-  Shortage Management
-  Alternative Solution
-  Excess Inventory Management