



**THE DATASHEET OF  
MT40A256M16LY-062E IT:F TR**



# DDR4 SDRAM

## MT40A1G4

## MT40A512M8

## MT40A256M16

### Features

- $V_{DD} = V_{DDQ} = 1.2V \pm 60mV$
- $V_{PP} = 2.5V, -125mV/+250mV$
- On-die, internal, adjustable  $V_{REFDQ}$  generation
- 1.2V pseudo open-drain I/O
- $T_C$  of 0°C to 95°C
  - 64ms, 8192-cycle refresh at 0°C to 85°C
  - 32ms at 85°C to 95°C
- 16 internal banks (x4, x8): 4 groups of 4 banks each
- 8 internal banks (x16): 2 groups of 4 banks each
- 8n-bit prefetch architecture
- Programmable data strobe preambles
- Data strobe preamble training
- Command/Address latency (CAL)
- Multipurpose register READ and WRITE capability
- Write and read leveling
- Self refresh mode
- Low-power auto self refresh (LPASR)
- Temperature controlled refresh (TCR)
- Fine granularity refresh
- Self refresh abort
- Maximum power saving
- Output driver calibration
- Nominal, park, and dynamic on-die termination (ODT)
- Data bus inversion (DBI) for data bus
- Command/Address (CA) parity

- Databus write cyclic redundancy check (CRC)
- Per-DRAM addressability
- Connectivity test (x16)
- Post package repair (PPR) and soft post package repair (sPPR) modes
- JEDEC JESD-79-4 compliant

### Options<sup>1</sup>

- Configuration
  - 1 Gig x 4
  - 512 Meg x 8
  - 256 Meg x 16
- FBGA package (Pb-free) – x4, x8
  - 78-ball (9mm x 11.5mm) – Rev. A
  - 78-ball (9mm x 10.5mm) – Rev. B
- FBGA package (Pb-free) – x16
  - 96-ball (9mm x 14mm) – Rev. A
  - 96-ball (9mm x 14mm) – Rev. B
- Timing – cycle time
  - 0.625ns @ CL = 22 (DDR4-3200)
  - 0.682ns @ CL = 20 (DDR4-2933)
  - 0.682ns @ CL = 21 (DDR4-2933)
  - 0.750ns @ CL = 18 (DDR4-2666)
  - 0.750ns @ CL = 19 (DDR4-2666)
  - 0.833ns @ CL = 16 (DDR4-2400)
  - 0.833ns @ CL = 17 (DDR4-2400)
  - 0.937ns @ CL = 15 (DDR4-2133)
  - 0.937ns @ CL = 16 (DDR4-2133)
  - 1.071ns @ CL = 13 (DDR4-1866)
- Operating temperature
  - Commercial ( $0^\circ \leq T_C \leq 95^\circ C$ )
  - Industrial ( $-40^\circ \leq T_C \leq 95^\circ C$ )
  - Revision

### Marking

1G4  
512M8  
256M16<sup>2</sup>

HX  
RH

HA  
GE

-062E  
-068E  
-068  
-75E  
-75  
-083E  
-083  
-093E  
-093  
-107E

None  
IT  
:A  
:B

- Notes:
1. Not all options listed can be combined to define an offered product. Use the part catalog search on <http://www.micron.com> for available offerings.
  2. Not available on Rev. A.
  3. Restricted and limited availability.

**Table 1: Key Timing Parameters**

Speed Grade	Data Rate (MT/s)	Target <sup>t</sup> RCD- <sup>t</sup> RP-CL	<sup>t</sup> RCD (ns)	<sup>t</sup> RP (ns)	CL (ns)
-062E <sup>6</sup>	3200	22-22-22	13.75	13.75	13.75
-068E <sup>5</sup>	2933	20-20-20	13.64	13.64	13.64
-068 <sup>5</sup>	2933	21-21-21	14.32	14.32	14.32
-075E <sup>4</sup>	2666	18-18-18	13.5	13.5	13.5
-075 <sup>4</sup>	2666	19-19-19	14.25	14.25	14.25
-083E <sup>3</sup>	2400	16-16-16	13.32	13.32	13.32
-083 <sup>3</sup>	2400	17-17-17	14.16	14.16	14.16
-093E <sup>2</sup>	2133	15-15-15	14.06	14.06	14.06
-093 <sup>2</sup>	2133	16-16-16	15	15	15
-107E <sup>1</sup>	1866	13-13-13	13.92	13.92	13.92

- Notes:
1. Backward compatible to 1600, CL = 11.
  2. Backward compatible to 1600, CL = 11 and 1866, CL = 13.
  3. Backward compatible to 1600, CL = 11; 1866, CL = 13; and 2133, CL = 15.
  4. Backward compatible to 1600, CL = 11; 1866, CL = 13; 2133, CL = 15; and 2400, CL = 17.
  5. Backward compatible to 1600, CL = 11; 1866, CL = 13; 2133, CL = 15; 2400, CL = 17; and 2666, CL = 19. Speed offering may have restricted availability.
  6. Backward compatible to 1600, CL = 11; 1866, CL = 13; 2133, CL = 15; 2400, CL = 17; 2666, CL = 19; and 2933, CL = 20 and CL = 21. Speed offering may have restricted availability.

**Table 2: Addressing**

Parameter	1024 Meg x 4	512 Meg x 8	256 Meg x 16
Number of bank groups	4	4	2
Bank group address	BG[1:0]	BG[1:0]	BG0
Bank count per group	4	4	4
Bank address in bank group	BA[1:0]	BA[1:0]	BA[1:0]
Row addressing	64K (A[15:0])	32K (A[14:0])	32K (A[14:0])
Column addressing	1K (A[9:0])	1K (A[9:0])	1K (A[9:0])
Page size <sup>1</sup>	512B / 1KB <sup>2</sup>	1KB	2KB

- Notes:
1. Page size is per bank, calculated as follows:  
Page size =  $2^{\text{COLBITS}} \times \text{ORG}/8$ , where COLBITS = the number of column address bits and ORG = the number of DQ bits.
  2. Die revision dependant.

## Contents

General Notes and Description .....	17
Description .....	17
Industrial Temperature .....	17
General Notes .....	17
Definitions of the Device-Pin Signal Level .....	18
Definitions of the Bus Signal Level .....	18
Ball Assignments .....	19
Ball Descriptions .....	21
Package Dimensions .....	24
State Diagram .....	28
Functional Description .....	30
RESET and Initialization Procedure .....	31
Power-Up and Initialization Sequence .....	31
RESET Initialization with Stable Power Sequence .....	34
Uncontrolled Power-Down Sequence .....	35
Programming Mode Registers .....	35
Mode Register 0 .....	38
Burst Length, Type, and Order .....	39
CAS Latency .....	40
Test Mode .....	41
Write Recovery(WR)/READ-to-PRECHARGE .....	41
DLL RESET .....	41
Mode Register 1 .....	42
DLL Enable/DLL Disable .....	43
Output Driver Impedance Control .....	44
ODT $R_{TT(NOM)}$ Values .....	44
Additive Latency .....	44
Write Leveling .....	44
Output Disable .....	45
Termination Data Strobe .....	45
Mode Register 2 .....	46
CAS WRITE Latency .....	48
Low-Power Auto Self Refresh .....	48
Dynamic ODT .....	48
Write Cyclic Redundancy Check Data Bus .....	48
Target Row Refresh Mode .....	48
Mode Register 3 .....	49
Multipurpose Register .....	50
WRITE Command Latency When CRC/DM is Enabled .....	51
Fine Granularity Refresh Mode .....	51
Temperature Sensor Status .....	51
Per-DRAM Addressability .....	51
Gear-Down Mode .....	51
Mode Register 4 .....	52
Post Package Repair Mode .....	53
Soft Post Package Repair Mode .....	53
WRITE Preamble .....	54
READ Preamble .....	54
READ Preamble Training .....	54
Temperature-Controlled Refresh .....	54



Command Address Latency .....	54
Internal V <sub>REF</sub> Monitor .....	54
Maximum Power Savings Mode .....	54
Mode Register 5 .....	56
Data Bus Inversion .....	57
Data Mask .....	58
CA Parity Persistent Error Mode .....	58
ODT Input Buffer for Power-Down .....	58
CA Parity Error Status .....	58
CRC Error Status .....	58
CA Parity Latency Mode .....	58
Mode Register 6 .....	59
<sup>t</sup> CCD_L Programming .....	60
V <sub>REFDQ</sub> Calibration Enable .....	60
V <sub>REFDQ</sub> Calibration Range .....	60
V <sub>REFDQ</sub> Calibration Value .....	60
Truth Tables .....	61
NOP Command .....	64
DESELECT Command .....	64
DLL-Off Mode .....	64
DLL-On/Off Switching Procedures .....	66
DLL Switch Sequence from DLL-On to DLL-Off .....	66
DLL-Off to DLL-On Procedure .....	68
Input Clock Frequency Change .....	69
Write Leveling .....	70
DRAM Setting for Write Leveling and DRAM TERMINATION Function in that Mode .....	71
Procedure Description .....	72
Write-Leveling Mode Exit .....	73
Command Address Latency .....	75
Low-Power Auto Self Refresh Mode .....	80
Manual Self Refresh Mode .....	80
Multipurpose Register .....	82
MPR Reads .....	83
MPR Readout Format .....	85
MPR Readout Serial Format .....	85
MPR Readout Parallel Format .....	86
MPR Readout Staggered Format .....	87
MPR READ Waveforms .....	88
MPR Writes .....	90
MPR WRITE Waveforms .....	91
MPR REFRESH Waveforms .....	92
Gear-Down Mode .....	95
Maximum Power-Saving Mode .....	98
Maximum Power-Saving Mode Entry .....	98
Maximum Power-Saving Mode Entry in PDA .....	99
CKE Transition During Maximum Power-Saving Mode .....	99
Maximum Power-Saving Mode Exit .....	99
Command/Address Parity .....	101
Per-DRAM Addressability .....	109
V <sub>REFDQ</sub> Calibration .....	112
V <sub>REFDQ</sub> Range and Levels .....	113
V <sub>REFDQ</sub> Step Size .....	113

V <sub>REFDQ</sub> Increment and Decrement Timing .....	114
V <sub>REFDQ</sub> Target Settings .....	118
Connectivity Test Mode .....	120
Pin Mapping .....	120
Minimum Terms Definition for Logic Equations .....	121
Logic Equations for a x4 Device, When Supported .....	121
Logic Equations for a x8 Device, When Supported .....	122
Logic Equations for a x16 Device .....	122
CT Input Timing Requirements .....	122
Post Package Repair and Soft Post Package Repair .....	124
Post Package Repair .....	124
PPR Row Repair .....	124
PPR Row Repair - Entry .....	124
PPR Row Repair – WRA Initiated (REF Commands Allowed) .....	125
PPR Row Repair – WR Initiated (REF Commands NOT Allowed) .....	126
sPPR Row Repair .....	128
PPR/sPPR Support Identifier .....	129
Target Row Refresh Mode .....	131
ACTIVATE Command .....	132
PRECHARGE Command .....	133
REFRESH Command .....	133
Temperature-Controlled Refresh Mode .....	135
TCR Mode – Normal Temperature Range .....	135
TCR Mode – Extended Temperature Range .....	135
Fine Granularity Refresh Mode .....	137
Mode Register and Command Truth Table .....	137
<sup>t</sup> REFI and <sup>t</sup> RFC Parameters .....	137
Changing Refresh Rate .....	140
Usage with TCR Mode .....	140
Self Refresh Entry and Exit .....	140
SELF REFRESH Operation .....	142
Self Refresh Abort .....	144
Self Refresh Exit with NOP Command .....	145
Power-Down Mode .....	147
Power-Down Clarifications – Case 1 .....	152
Power-Down Entry, Exit Timing with CAL .....	153
ODT Input Buffer Disable Mode for Power-Down .....	156
CRC Write Data Feature .....	158
CRC Write Data .....	158
WRITE CRC DATA Operation .....	158
DBI <sub>n</sub> and CRC Both Enabled .....	159
DM <sub>n</sub> and CRC Both Enabled .....	159
DM <sub>n</sub> and DBI <sub>n</sub> Conflict During Writes with CRC Enabled .....	159
CRC and Write Preamble Restrictions .....	159
CRC Simultaneous Operation Restrictions .....	159
CRC Polynomial .....	159
CRC Combinatorial Logic Equations .....	160
Burst Ordering for BL8 .....	161
CRC Data Bit Mapping .....	161
CRC Enabled With BC4 .....	162
CRC with BC4 Data Bit Mapping .....	162
CRC Equations for x8 Device in BC4 Mode with A2 = 0 and A2 = 1 .....	165



CRC Error Handling .....	166
CRC Write Data Flow Diagram .....	168
Data Bus Inversion .....	169
DBI During a WRITE Operation .....	169
DBI During a READ Operation .....	170
Data Mask .....	171
Programmable Preamble Modes and DQS Postambles .....	172
WRITE Preamble Mode .....	172
READ Preamble Mode .....	176
READ Preamble Training .....	176
WRITE Postamble .....	177
READ Postamble .....	177
Bank Access Operation .....	179
READ Operation .....	183
Read Timing Definitions .....	183
Read Timing – Clock-to-Data Strobe Relationship .....	184
Read Timing – Data Strobe-to-Data Relationship .....	185
<sup>t</sup> LZ(DQS), <sup>t</sup> LZ(DQ), <sup>t</sup> HZ(DQS), and <sup>t</sup> HZ(DQ) Calculations .....	186
<sup>t</sup> RPRE Calculation .....	188
<sup>t</sup> RPST Calculation .....	189
READ Burst Operation .....	190
READ Operation Followed by Another READ Operation .....	192
READ Operation Followed by WRITE Operation .....	197
READ Operation Followed by PRECHARGE Operation .....	203
READ Operation with Read Data Bus Inversion (DBI) .....	206
READ Operation with Command/Address Parity (CA Parity) .....	207
READ Followed by WRITE with CRC Enabled .....	209
READ Operation with Command/Address Latency (CAL) Enabled .....	210
WRITE Operation .....	212
Write Timing Definitions .....	212
Write Timing – Clock-to-Data Strobe Relationship .....	212
Write Timing – Data Strobe-to-Data Relationship .....	213
WRITE Burst Operation .....	217
WRITE Operation Followed by Another WRITE Operation .....	219
WRITE Operation Followed by READ Operation .....	225
WRITE Operation Followed by PRECHARGE Operation .....	229
WRITE Operation with WRITE DBI Enabled .....	232
WRITE Operation with CA Parity Enabled .....	234
WRITE Operation with Write CRC Enabled .....	235
Write Timing Violations .....	240
Motivation .....	240
Data Setup and Hold Violations .....	240
Strobe-to-Strobe and Strobe-to-Clock Violations .....	240
ZQ CALIBRATION Commands .....	241
On-Die Termination .....	243
ODT Mode Register and ODT State Table .....	243
ODT Read Disable State Table .....	244
Synchronous ODT Mode .....	245
ODT Latency and Posted ODT .....	245
Timing Parameters .....	245
ODT During Reads .....	247
Dynamic ODT .....	248



Functional Description .....	248
Asynchronous ODT Mode .....	251
Electrical Specifications .....	252
Absolute Ratings .....	252
DRAM Component Operating Temperature Range .....	252
Electrical Characteristics – AC and DC Operating Conditions .....	253
Supply Operating Conditions .....	253
Leakages .....	253
V <sub>REFCA</sub> Supply .....	254
V <sub>REFDQ</sub> Supply and Calibration Ranges .....	255
V <sub>REFDQ</sub> Ranges .....	256
Electrical Characteristics – AC and DC Single-Ended Input Measurement Levels .....	257
RESET_n Input Levels .....	257
Command/Address Input Levels .....	258
Data Receiver Input Requirements .....	261
Connectivity Test (CT) Mode Input Levels .....	264
Electrical Characteristics – AC and DC Differential Input Measurement Levels .....	268
Differential Inputs .....	268
Single-Ended Requirements for CK Differential Signals .....	269
Slew Rate Definitions for CK Differential Input Signals .....	270
CK Differential Input Cross Point Voltage .....	271
DQS Differential Input Signal Definition and Swing Requirements .....	272
DQS Differential Input Cross Point Voltage .....	274
Slew Rate Definitions for DQS Differential Input Signals .....	275
Electrical Characteristics – Overshoot and Undershoot Specifications .....	277
Address, Command, and Control Overshoot and Undershoot Specifications .....	277
Clock Overshoot and Undershoot Specifications .....	278
Data, Strobe, and Mask Overshoot and Undershoot Specifications .....	279
Electrical Characteristics – AC and DC Output Measurement Levels .....	279
Single-Ended Outputs .....	279
Differential Outputs .....	281
Reference Load for AC Timing and Output Slew Rate .....	282
Connectivity Test Mode Output Levels .....	283
Electrical Characteristics – AC and DC Output Driver Characteristics .....	285
Output Driver Electrical Characteristics .....	285
Output Driver Temperature and Voltage Sensitivity .....	288
Alert Driver .....	288
Electrical Characteristics – On-Die Termination Characteristics .....	289
ODT Levels and I-V Characteristics .....	289
ODT Temperature and Voltage Sensitivity .....	291
ODT Timing Definitions .....	291
DRAM Package Electrical Specifications .....	295
Thermal Characteristics .....	299
Current Specifications – Measurement Conditions .....	300
I <sub>DD</sub> , I <sub>PP</sub> , and I <sub>DDQ</sub> Measurement Conditions .....	300
I <sub>DD</sub> Definitions .....	301
Current Specifications – Patterns and Test Conditions .....	305
Current Test Definitions and Patterns .....	305
I <sub>DD</sub> Specifications .....	314
Current Specifications – Limits .....	315
Speed Bin Tables .....	319
Refresh Parameters By Device Density .....	328



---

Electrical Characteristics and AC Timing Parameters .....	329
Electrical Characteristics and AC Timing Parameters: 2666 Through 3200 .....	341
EDY4016 Option and Exception Lists .....	353
Mode Register Settings .....	353
Options Tables .....	353

## List of Figures

Figure 1: 78-Ball x4, x8 Ball Assignments .....	19
Figure 2: 96-Ball x16 Ball Assignments .....	20
Figure 3: 78-Ball FBGA – x4, x8 "HX" .....	24
Figure 4: 78-Ball FBGA – x4, x8 "RH" .....	25
Figure 5: 96-Ball FBGA – x16 "HA" .....	26
Figure 6: 96-Ball FBGA – x16 "GE" .....	27
Figure 7: Simplified State Diagram .....	28
Figure 8: RESET and Initialization Sequence at Power-On Ramping .....	33
Figure 9: RESET Procedure at Power Stable Condition .....	34
Figure 10: <sup>t</sup> MRD Timing .....	36
Figure 11: <sup>t</sup> MOD Timing .....	36
Figure 12: DLL-Off Mode Read Timing Operation .....	65
Figure 13: DLL Switch Sequence from DLL-On to DLL-Off .....	67
Figure 14: DLL Switch Sequence from DLL-Off to DLL-On .....	68
Figure 15: Write-Leveling Concept, Example 1 .....	70
Figure 16: Write-Leveling Concept, Example 2 .....	71
Figure 17: Write-Leveling Sequence (DQS Capturing CK LOW at T1 and CK HIGH at T2) .....	73
Figure 18: Write-Leveling Exit .....	74
Figure 19: CAL Timing Definition .....	75
Figure 20: CAL Timing Example (Consecutive CS <sub>n</sub> = LOW) .....	75
Figure 21: CAL Enable Timing – <sup>t</sup> MOD <sub>CAL</sub> .....	76
Figure 22: <sup>t</sup> MOD <sub>CAL</sub> , MRS to Valid Command Timing with CAL Enabled .....	76
Figure 23: CAL Enabling MRS to Next MRS Command, <sup>t</sup> MRD <sub>CAL</sub> .....	77
Figure 24: <sup>t</sup> MRD <sub>CAL</sub> , Mode Register Cycle Time With CAL Enabled .....	77
Figure 25: Consecutive READ BL8, CAL3, 1 <sup>t</sup> CK Preamble, Different Bank Group .....	78
Figure 26: Consecutive READ BL8, CAL4, 1 <sup>t</sup> CK Preamble, Different Bank Group .....	78
Figure 27: Auto Self Refresh Ranges .....	81
Figure 28: MPR Block Diagram .....	82
Figure 29: MPR READ Timing .....	88
Figure 30: MPR Back-to-Back READ Timing .....	89
Figure 31: MPR READ-to-WRITE Timing .....	90
Figure 32: MPR WRITE and WRITE-to-READ Timing .....	91
Figure 33: MPR Back-to-Back WRITE Timing .....	92
Figure 34: REFRESH Timing .....	92
Figure 35: READ-to-REFRESH Timing .....	93
Figure 36: WRITE-to-REFRESH Timing .....	93
Figure 37: Clock Mode Change from 1/2 Rate to 1/4 Rate (Initialization) .....	96
Figure 38: Clock Mode Change After Exiting Self Refresh .....	96
Figure 39: Comparison Between Gear-Down Disable and Gear-Down Enable .....	97
Figure 40: Maximum Power-Saving Mode Entry .....	98
Figure 41: Maximum Power-Saving Mode Entry with PDA .....	99
Figure 42: Maintaining Maximum Power-Saving Mode with CKE Transition .....	99
Figure 43: Maximum Power-Saving Mode Exit .....	100
Figure 44: Command/Address Parity Operation .....	101
Figure 45: Command/Address Parity During Normal Operation .....	103
Figure 46: Persistent CA Parity Error Checking Operation .....	104
Figure 47: CA Parity Error Checking – SRE Attempt .....	104
Figure 48: CA Parity Error Checking – SRX Attempt .....	105
Figure 49: CA Parity Error Checking – PDE/PDX .....	105
Figure 50: Parity Entry Timing Example – <sup>t</sup> MRD <sub>PAR</sub> .....	106

Figure 51: Parity Entry Timing Example – $t_{MOD\_PAR}$ .....	106
Figure 52: Parity Exit Timing Example – $t_{MRD\_PAR}$ .....	106
Figure 53: Parity Exit Timing Example – $t_{MOD\_PAR}$ .....	107
Figure 54: CA Parity Flow Diagram .....	108
Figure 55: PDA Operation Enabled, BL8 .....	110
Figure 56: PDA Operation Enabled, BC4 .....	110
Figure 57: MRS PDA Exit .....	111
Figure 58: $V_{REFDQ}$ Voltage Range .....	112
Figure 59: Example of $V_{REF}$ Set Tolerance and Step Size .....	114
Figure 60: $V_{REFDQ}$ Timing Diagram for $V_{REF,time}$ Parameter .....	115
Figure 61: $V_{REFDQ}$ Training Mode Entry and Exit Timing Diagram .....	116
Figure 62: $V_{REF}$ Step: Single Step Size Increment Case .....	117
Figure 63: $V_{REF}$ Step: Single Step Size Decrement Case .....	117
Figure 64: $V_{REF}$ Full Step: From $V_{REF,min}$ to $V_{REF,max}$ Case .....	118
Figure 65: $V_{REF}$ Full Step: From $V_{REF,max}$ to $V_{REF,min}$ Case .....	118
Figure 66: $V_{REFDQ}$ Equivalent Circuit .....	119
Figure 67: Connectivity Test Mode Entry .....	123
Figure 68: PPR WRA – Entry .....	126
Figure 69: PPR WRA – Repair and Exit .....	126
Figure 70: PPR WR – Entry .....	127
Figure 71: PPR WR – Repair and Exit .....	127
Figure 72: sPPR – Entry, Repair, and Exit .....	129
Figure 73: $t_{RRD}$ Timing .....	132
Figure 74: $t_{FAW}$ Timing .....	132
Figure 75: REFRESH Command Timing .....	134
Figure 76: Postponing REFRESH Commands (Example) .....	134
Figure 77: Pulling In REFRESH Commands (Example) .....	134
Figure 78: TCR Mode Example <sup>1</sup> .....	136
Figure 79: 4Gb with Fine Granularity Refresh Mode Example .....	139
Figure 80: OTF REFRESH Command Timing .....	140
Figure 81: Self Refresh Entry/Exit Timing .....	143
Figure 82: Self Refresh Entry/Exit Timing with CAL Mode .....	144
Figure 83: Self Refresh Abort .....	145
Figure 84: Self Refresh Exit with NOP Command .....	146
Figure 85: Active Power-Down Entry and Exit .....	148
Figure 86: Power-Down Entry After Read and Read with Auto Precharge .....	149
Figure 87: Power-Down Entry After Write and Write with Auto Precharge .....	149
Figure 88: Power-Down Entry After Write .....	150
Figure 89: Precharge Power-Down Entry and Exit .....	150
Figure 90: REFRESH Command to Power-Down Entry .....	151
Figure 91: Active Command to Power-Down Entry .....	151
Figure 92: PRECHARGE/PRECHARGE ALL Command to Power-Down Entry .....	152
Figure 93: MRS Command to Power-Down Entry .....	152
Figure 94: Power-Down Entry/Exit Clarifications – Case 1 .....	153
Figure 95: Active Power-Down Entry and Exit Timing with CAL .....	154
Figure 96: REFRESH Command to Power-Down Entry with CAL .....	155
Figure 97: ODT Power-Down Entry with ODT Buffer Disable Mode .....	156
Figure 98: ODT Power-Down Exit with ODT Buffer Disable Mode .....	157
Figure 99: CRC Write Data Operation .....	158
Figure 100: CRC Error Reporting .....	167
Figure 101: CA Parity Flow Diagram .....	168
Figure 102: $1^tCK$ vs. $2^tCK$ WRITE Preamble Mode .....	172

Figure 103: 1 <sup>t</sup> CK vs. 2 <sup>t</sup> CK WRITE Preamble Mode, <sup>t</sup> CCD = 4 .....	174
Figure 104: 1 <sup>t</sup> CK vs. 2 <sup>t</sup> CK WRITE Preamble Mode, <sup>t</sup> CCD = 5 .....	175
Figure 105: 1 <sup>t</sup> CK vs. 2 <sup>t</sup> CK WRITE Preamble Mode, <sup>t</sup> CCD = 6 .....	175
Figure 106: 1 <sup>t</sup> CK vs. 2 <sup>t</sup> CK READ Preamble Mode .....	176
Figure 107: READ Preamble Training .....	177
Figure 108: WRITE Postamble .....	177
Figure 109: READ Postamble .....	178
Figure 110: Bank Group x4/x8 Block Diagram .....	179
Figure 111: READ Burst <sup>t</sup> CCD_S and <sup>t</sup> CCD_L Examples .....	180
Figure 112: Write Burst <sup>t</sup> CCD_S and <sup>t</sup> CCD_L Examples .....	180
Figure 113: <sup>t</sup> RRD Timing .....	181
Figure 114: <sup>t</sup> WTR_S Timing (WRITE-to-READ, Different Bank Group, CRC and DM Disabled) .....	181
Figure 115: <sup>t</sup> WTR_L Timing (WRITE-to-READ, Same Bank Group, CRC and DM Disabled) .....	182
Figure 116: Read Timing Definition .....	184
Figure 117: Clock-to-Data Strobe Relationship .....	185
Figure 118: Data Strobe-to-Data Relationship .....	186
Figure 119: <sup>t</sup> LZ and <sup>t</sup> HZ Method for Calculating Transitions and Endpoints .....	187
Figure 120: <sup>t</sup> RPRE Method for Calculating Transitions and Endpoints .....	188
Figure 121: <sup>t</sup> RPST Method for Calculating Transitions and Endpoints .....	189
Figure 122: READ Burst Operation, RL = 11 (AL = 0, CL = 11, BL8) .....	190
Figure 123: READ Burst Operation, RL = 21 (AL = 10, CL = 11, BL8) .....	191
Figure 124: Consecutive READ (BL8) with 1 <sup>t</sup> CK Preamble in Different Bank Group .....	192
Figure 125: Consecutive READ (BL8) with 2 <sup>t</sup> CK Preamble in Different Bank Group .....	192
Figure 126: Nonconsecutive READ (BL8) with 1 <sup>t</sup> CK Preamble in Same or Different Bank Group .....	193
Figure 127: Nonconsecutive READ (BL8) with 2 <sup>t</sup> CK Preamble in Same or Different Bank Group .....	193
Figure 128: READ (BC4) to READ (BC4) with 1 <sup>t</sup> CK Preamble in Different Bank Group .....	194
Figure 129: READ (BC4) to READ (BC4) with 2 <sup>t</sup> CK Preamble in Different Bank Group .....	194
Figure 130: READ (BL8) to READ (BC4) OTF with 1 <sup>t</sup> CK Preamble in Different Bank Group .....	195
Figure 131: READ (BL8) to READ (BC4) OTF with 2 <sup>t</sup> CK Preamble in Different Bank Group .....	195
Figure 132: READ (BC4) to READ (BL8) OTF with 1 <sup>t</sup> CK Preamble in Different Bank Group .....	196
Figure 133: READ (BC4) to READ (BL8) OTF with 2 <sup>t</sup> CK Preamble in Different Bank Group .....	196
Figure 134: READ (BL8) to WRITE (BL8) with 1 <sup>t</sup> CK Preamble in Same or Different Bank Group .....	197
Figure 135: READ (BL8) to WRITE (BL8) with 2 <sup>t</sup> CK Preamble in Same or Different Bank Group .....	197
Figure 136: READ (BC4) OTF to WRITE (BC4) OTF with 1 <sup>t</sup> CK Preamble in Same or Different Bank Group .....	198
Figure 137: READ (BC4) OTF to WRITE (BC4) OTF with 2 <sup>t</sup> CK Preamble in Same or Different Bank Group .....	199
Figure 138: READ (BC4) Fixed to WRITE (BC4) Fixed with 1 <sup>t</sup> CK Preamble in Same or Different Bank Group .....	199
Figure 139: READ (BC4) Fixed to WRITE (BC4) Fixed with 2 <sup>t</sup> CK Preamble in Same or Different Bank Group .....	200
Figure 140: READ (BC4) to WRITE (BL8) OTF with 1 <sup>t</sup> CK Preamble in Same or Different Bank Group .....	201
Figure 141: READ (BC4) to WRITE (BL8) OTF with 2 <sup>t</sup> CK Preamble in Same or Different Bank Group .....	201
Figure 142: READ (BL8) to WRITE (BC4) OTF with 1 <sup>t</sup> CK Preamble in Same or Different Bank Group .....	202
Figure 143: READ (BL8) to WRITE (BC4) OTF with 2 <sup>t</sup> CK Preamble in Same or Different Bank Group .....	202
Figure 144: READ to PRECHARGE with 1 <sup>t</sup> CK Preamble .....	203
Figure 145: READ to PRECHARGE with 2 <sup>t</sup> CK Preamble .....	204
Figure 146: READ to PRECHARGE with Additive Latency and 1 <sup>t</sup> CK Preamble .....	204
Figure 147: READ with Auto Precharge and 1 <sup>t</sup> CK Preamble .....	205
Figure 148: READ with Auto Precharge, Additive Latency, and 1 <sup>t</sup> CK Preamble .....	206
Figure 149: Consecutive READ (BL8) with 1 <sup>t</sup> CK Preamble and DBI in Different Bank Group .....	206
Figure 150: Consecutive READ (BL8) with 1 <sup>t</sup> CK Preamble and CA Parity in Different Bank Group .....	207
Figure 151: READ (BL8) to WRITE (BL8) with 1 <sup>t</sup> CK Preamble and CA Parity in Same or Different Bank Group ...	208
Figure 152: READ (BL8) to WRITE (BL8 or BC4: OTF) with 1 <sup>t</sup> CK Preamble and Write CRC in Same or Different Bank Group .....	209

Figure 153: READ (BC4: Fixed) to WRITE (BC4: Fixed) with 1 <sup>t</sup> CK Preamble and Write CRC in Same or Different Bank Group .....	210
Figure 154: Consecutive READ (BL8) with CAL (3 <sup>t</sup> CK) and 1 <sup>t</sup> CK Preamble in Different Bank Group .....	210
Figure 155: Consecutive READ (BL8) with CAL (4 <sup>t</sup> CK) and 1 <sup>t</sup> CK Preamble in Different Bank Group .....	211
Figure 156: Write Timing Definition .....	213
Figure 157: Rx Compliance Mask .....	214
Figure 158: V <sub>CENT_DQ</sub> V <sub>REFDQ</sub> Voltage Variation .....	214
Figure 159: Rx Mask DQ-to-DQS Timings .....	215
Figure 160: Rx Mask DQ-to-DQS DRAM-Based Timings .....	216
Figure 161: Example of Data Input Requirements Without Training .....	217
Figure 162: WRITE Burst Operation, WL = 9 (AL = 0, CWL = 9, BL8) .....	218
Figure 163: WRITE Burst Operation, WL = 19 (AL = 10, CWL = 9, BL8) .....	219
Figure 164: Consecutive WRITE (BL8) with 1 <sup>t</sup> CK Preamble in Different Bank Group .....	219
Figure 165: Consecutive WRITE (BL8) with 2 <sup>t</sup> CK Preamble in Different Bank Group .....	220
Figure 166: Nonconsecutive WRITE (BL8) with 1 <sup>t</sup> CK Preamble in Same or Different Bank Group .....	221
Figure 167: Nonconsecutive WRITE (BL8) with 2 <sup>t</sup> CK Preamble in Same or Different Bank Group .....	221
Figure 168: WRITE (BC4) OTF to WRITE (BC4) OTF with 1 <sup>t</sup> CK Preamble in Different Bank Group .....	222
Figure 169: WRITE (BC4) OTF to WRITE (BC4) OTF with 2 <sup>t</sup> CK Preamble in Different Bank Group .....	223
Figure 170: WRITE (BC4) Fixed to WRITE (BC4) Fixed with 1 <sup>t</sup> CK Preamble in Different Bank Group .....	223
Figure 171: WRITE (BL8) to WRITE (BC4) OTF with 1 <sup>t</sup> CK Preamble in Different Bank Group .....	224
Figure 172: WRITE (BC4) OTF to WRITE (BL8) with 1 <sup>t</sup> CK Preamble in Different Bank Group .....	225
Figure 173: WRITE (BL8) to READ (BL8) with 1 <sup>t</sup> CK Preamble in Different Bank Group .....	225
Figure 174: WRITE (BL8) to READ (BL8) with 1 <sup>t</sup> CK Preamble in Same Bank Group .....	226
Figure 175: WRITE (BC4) OTF to READ (BC4) OTF with 1 <sup>t</sup> CK Preamble in Different Bank Group .....	227
Figure 176: WRITE (BC4) OTF to READ (BC4) OTF with 1 <sup>t</sup> CK Preamble in Same Bank Group .....	227
Figure 177: WRITE (BC4) Fixed to READ (BC4) Fixed with 1 <sup>t</sup> CK Preamble in Different Bank Group .....	228
Figure 178: WRITE (BC4) Fixed to READ (BC4) Fixed with 1 <sup>t</sup> CK Preamble in Same Bank Group .....	228
Figure 179: WRITE (BL8/BC4-OTF) to PRECHARGE with 1 <sup>t</sup> CK Preamble .....	229
Figure 180: WRITE (BC4-Fixed) to PRECHARGE with 1 <sup>t</sup> CK Preamble .....	230
Figure 181: WRITE (BL8/BC4-OTF) to Auto PRECHARGE with 1 <sup>t</sup> CK Preamble .....	230
Figure 182: WRITE (BC4-Fixed) to Auto PRECHARGE with 1 <sup>t</sup> CK Preamble .....	231
Figure 183: WRITE (BL8/BC4-OTF) with 1 <sup>t</sup> CK Preamble and DBI .....	232
Figure 184: WRITE (BC4-Fixed) with 1 <sup>t</sup> CK Preamble and DBI .....	233
Figure 185: Consecutive Write (BL8) with 1 <sup>t</sup> CK Preamble and CA Parity in Different Bank Group .....	234
Figure 186: Consecutive WRITE (BL8/BC4-OTF) with 1 <sup>t</sup> CK Preamble and Write CRC in Same or Different Bank Group .....	235
Figure 187: Consecutive WRITE (BC4-Fixed) with 1 <sup>t</sup> CK Preamble and Write CRC in Same or Different Bank Group .....	236
Figure 188: Nonconsecutive WRITE (BL8/BC4-OTF) with 1 <sup>t</sup> CK Preamble and Write CRC in Same or Different Bank Group .....	237
Figure 189: Nonconsecutive WRITE (BL8/BC4-OTF) with 2 <sup>t</sup> CK Preamble and Write CRC in Same or Different Bank Group .....	238
Figure 190: WRITE (BL8/BC4-OTF/Fixed) with 1 <sup>t</sup> CK Preamble and Write CRC in Same or Different Bank Group .....	239
Figure 191: ZQ Calibration Timing .....	242
Figure 192: Functional Representation of ODT .....	243
Figure 193: Synchronous ODT Timing with BL8 .....	246
Figure 194: Synchronous ODT with BC4 .....	246
Figure 195: ODT During Reads .....	247
Figure 196: Dynamic ODT (1 <sup>t</sup> CK Preamble; CL = 14, CWL = 11, BL = 8, AL = 0, CRC Disabled) .....	249
Figure 197: Dynamic ODT Overlapped with R <sub>TT(NOM)</sub> (CL = 14, CWL = 11, BL = 8, AL = 0, CRC Disabled) .....	250
Figure 198: Asynchronous ODT Timings with DLL Off .....	251
Figure 199: V <sub>REFDQ</sub> Voltage Range .....	254

Figure 200: RESET_n Input Slew Rate Definition .....	258
Figure 201: Single-Ended Input Slew Rate Definition .....	260
Figure 202: DQ Slew Rate Definitions .....	261
Figure 203: Rx Mask Relative to <sup>t</sup> DS/ <sup>t</sup> DH .....	263
Figure 204: Rx Mask Without Write Training .....	264
Figure 205: TEN Input Slew Rate Definition .....	265
Figure 206: CT Type-A Input Slew Rate Definition .....	265
Figure 207: CT Type-B Input Slew Rate Definition .....	266
Figure 208: CT Type-C Input Slew Rate Definition .....	267
Figure 209: CT Type-D Input Slew Rate Definition .....	267
Figure 210: Differential AC Swing and “Time Exceeding AC-Level” <sup>t</sup> DVAC .....	268
Figure 211: Single-Ended Requirements for CK .....	270
Figure 212: Differential Input Slew Rate Definition for CK_t, CK_c .....	271
Figure 213: V <sub>IX(CK)</sub> Definition .....	271
Figure 214: Differential Input Signal Definition for DQS_t, DQS_c .....	272
Figure 215: DQS_t, DQS_c Input Peak Voltage Calculation and Range of Exempt non-Monotonic Signaling .....	273
Figure 216: V <sub>IXDQS</sub> Definition .....	274
Figure 217: Differential Input Slew Rate and Input Level Definition for DQS_t, DQS_c .....	275
Figure 218: ADDR, CMD, CNTL Overshoot and Undershoot Definition .....	277
Figure 219: CK Overshoot and Undershoot Definition .....	278
Figure 220: Data, Strobe, and Mask Overshoot and Undershoot Definition .....	279
Figure 221: Single-ended Output Slew Rate Definition .....	280
Figure 222: Differential Output Slew Rate Definition .....	282
Figure 223: Reference Load For AC Timing and Output Slew Rate .....	283
Figure 224: Connectivity Test Mode Reference Test Load .....	283
Figure 225: Connectivity Test Mode Output Slew Rate Definition .....	284
Figure 226: Output Driver: Definition of Voltages and Currents .....	285
Figure 227: Alert Driver .....	288
Figure 228: ODT Definition of Voltages and Currents .....	289
Figure 229: ODT Timing Reference Load .....	291
Figure 230: <sup>t</sup> ADC Definition with Direct ODT Control .....	293
Figure 231: <sup>t</sup> ADC Definition with Dynamic ODT Control .....	293
Figure 232: <sup>t</sup> AOFAS and <sup>t</sup> AONAS Definitions .....	294
Figure 233: Thermal Measurement Point .....	299
Figure 234: Measurement Setup and Test Load for I <sub>DDX</sub> , I <sub>DDPx</sub> , and I <sub>DDQx</sub> .....	301
Figure 235: Correlation: Simulated Channel I/O Power to Actual Channel I/O Power .....	301

## List of Tables

Table 1: Key Timing Parameters .....	2
Table 2: Addressing .....	2
Table 3: Ball Descriptions .....	21
Table 4: State Diagram Command Definitions .....	29
Table 5: Address Pin Mapping .....	38
Table 6: MR0 Register Definition .....	38
Table 7: Burst Type and Burst Order .....	40
Table 8: Address Pin Mapping .....	42
Table 9: MR1 Register Definition .....	42
Table 10: Additive Latency (AL) Settings .....	44
Table 11: TDQS Function Matrix .....	45
Table 12: Address Pin Mapping .....	46
Table 13: MR2 Register Definition .....	46
Table 14: Address Pin Mapping .....	49
Table 15: MR3 Register Definition .....	49
Table 16: Address Pin Mapping .....	52
Table 17: MR4 Register Definition .....	52
Table 18: Address Pin Mapping .....	56
Table 19: MR5 Register Definition .....	56
Table 20: Address Pin Mapping .....	59
Table 21: MR6 Register Definition .....	59
Table 22: Truth Table – Command .....	61
Table 23: Truth Table – CKE .....	63
Table 24: MR Settings for Leveling Procedures .....	71
Table 25: DRAM TERMINATION Function in Leveling Mode .....	71
Table 26: Auto Self Refresh Mode .....	80
Table 27: MR3 Setting for the MPR Access Mode .....	82
Table 28: DRAM Address to MPR UI Translation .....	82
Table 29: MPR Page and MPRx Definitions .....	83
Table 30: MPR Readout Serial Format .....	85
Table 31: MPR Readout – Parallel Format .....	86
Table 32: MPR Readout Staggered Format, x4 .....	87
Table 33: MPR Readout Staggered Format, x4 – Consecutive READs .....	87
Table 34: MPR Readout Staggered Format, x8 and x16 .....	88
Table 35: Mode Register Setting for CA Parity .....	103
Table 36: V <sub>REFDQ</sub> Range and Levels .....	113
Table 37: V <sub>REFDQ</sub> Settings (V <sub>DDQ</sub> = 1.2V) .....	119
Table 38: Connectivity Mode Pin Description and Switching Levels .....	121
Table 39: PPR MR0 Guard Key Settings .....	125
Table 40: DDR4 PPR Timing Parameters DDR4-1600 through DDR4-3200 .....	128
Table 41: DDR4 sPPR Timing Parameters DDR4-1600 through DDR4-3200 .....	129
Table 42: DDR4 Repair Mode Support Identifier .....	129
Table 43: MAC Encoding of MPR Page 3 MPR3 .....	131
Table 44: Normal <sup>t</sup> REFI Refresh (TCR Disabled) .....	135
Table 45: Normal <sup>t</sup> REFI Refresh (TCR Enabled) .....	136
Table 46: MRS Definition .....	137
Table 47: REFRESH Command Truth Table .....	137
Table 48: <sup>t</sup> REFI and <sup>t</sup> RFC Parameters .....	138
Table 49: Power-Down Entry Definitions .....	147
Table 50: CRC Error Detection Coverage .....	159

Table 51: CRC Data Mapping for x4 Devices, BL8 .....	161
Table 52: CRC Data Mapping for x8 Devices, BL8 .....	161
Table 53: CRC Data Mapping for x16 Devices, BL8 .....	162
Table 54: CRC Data Mapping for x4 Devices, BC4 .....	162
Table 55: CRC Data Mapping for x8 Devices, BC4 .....	163
Table 56: CRC Data Mapping for x16 Devices, BC4 .....	164
Table 57: DBI vs. DM vs. TDQS Function Matrix .....	169
Table 58: DBI Write, DQ Frame Format (x8) .....	169
Table 59: DBI Write, DQ Frame Format (x16) .....	169
Table 60: DBI Read, DQ Frame Format (x8) .....	170
Table 61: DBI Read, DQ Frame Format (x16) .....	170
Table 62: DM vs. TDQS vs. DBI Function Matrix .....	171
Table 63: Data Mask, DQ Frame Format (x8) .....	171
Table 64: Data Mask, DQ Frame Format (x16) .....	171
Table 65: CWL Selection .....	173
Table 66: DDR4 Bank Group Timing Examples .....	179
Table 67: Termination State Table .....	244
Table 68: Read Termination Disable Window .....	244
Table 69: ODT Latency at DDR4-1600/-1866/-2133/-2400/-2666/-3200 .....	245
Table 70: Dynamic ODT Latencies and Timing (1 <sup>t</sup> CK Preamble Mode and CRC Disabled) .....	248
Table 71: Dynamic ODT Latencies and Timing with Preamble Mode and CRC Mode Matrix .....	249
Table 72: Absolute Maximum Ratings .....	252
Table 73: Temperature Range .....	252
Table 74: Recommended Supply Operating Conditions .....	253
Table 75: V <sub>DD</sub> Slew Rate .....	253
Table 76: Leakages .....	254
Table 77: V <sub>REFDQ</sub> Specification .....	256
Table 78: V <sub>REFDQ</sub> Range and Levels .....	257
Table 79: RESET <sub>n</sub> Input Levels (CMOS) .....	257
Table 80: Command and Address Input Levels: DDR4-1600 Through DDR4-2400 .....	258
Table 81: Command and Address Input Levels: DDR4-2666 .....	259
Table 82: Command and Address Input Levels: DDR4-2933 and DDR4-3200 .....	259
Table 83: Single-Ended Input Slew Rates .....	259
Table 84: DQ Input Receiver Specifications .....	262
Table 85: Rx Mask and <sup>t</sup> DS/ <sup>t</sup> DH Without Write Training .....	264
Table 86: TEN Input Levels (CMOS) .....	264
Table 87: CT Type-A Input Levels .....	265
Table 88: CT Type-B Input Levels .....	266
Table 89: CT Type-C Input Levels (CMOS) .....	266
Table 90: CT Type-D Input Levels .....	267
Table 91: Differential Input Swing Requirements for CK <sub>t</sub> , CK <sub>c</sub> .....	268
Table 92: Minimum Time AC Time <sup>t</sup> DVAC for CK .....	269
Table 93: Single-Ended Requirements for CK .....	270
Table 94: CK Differential Input Slew Rate Definition .....	270
Table 95: Cross Point Voltage For CK Differential Input Signals at DDR4-1600 through DDR4-2400 .....	272
Table 96: Cross Point Voltage For CK Differential Input Signals at DDR4-2666 through DDR4-3200 .....	272
Table 97: DDR4-1600 through DDR4-2400 Differential Input Swing Requirements for DQS <sub>t</sub> , DQS <sub>c</sub> .....	273
Table 98: DDR4-2633 through DDR4-3200 Differential Input Swing Requirements for DQS <sub>t</sub> , DQS <sub>c</sub> .....	273
Table 99: Cross Point Voltage For Differential Input Signals DQS .....	274
Table 100: DQS Differential Input Slew Rate Definition .....	275
Table 101: DDR4-1600 through DDR4-2400 Differential Input Slew Rate and Input Levels for DQS <sub>t</sub> , DQS <sub>c</sub> ...	275
Table 102: DDR4-2666 through DDR4-3200 Differential Input Slew Rate and Input Levels for DQS <sub>t</sub> , DQS <sub>c</sub> ...	276

Table 103: ADDR, CMD, CNTL Overshoot and Undershoot/Specifications .....	277
Table 104: CK Overshoot and Undershoot/ Specifications .....	278
Table 105: Data, Strobe, and Mask Overshoot and Undershoot/ Specifications .....	279
Table 106: Single-Ended Output Levels .....	279
Table 107: Single-Ended Output Slew Rate Definition .....	280
Table 108: Single-Ended Output Slew Rate .....	281
Table 109: Differential Output Levels .....	281
Table 110: Differential Output Slew Rate Definition .....	281
Table 111: Differential Output Slew Rate .....	282
Table 112: Connectivity Test Mode Output Levels .....	283
Table 113: Connectivity Test Mode Output Slew Rate .....	284
Table 114: Strong Mode (34Ω) Output Driver Electrical Characteristics .....	286
Table 115: Weak Mode (48Ω) Output Driver Electrical Characteristics .....	287
Table 116: Output Driver Sensitivity Definitions .....	288
Table 117: Output Driver Voltage and Temperature Sensitivity .....	288
Table 118: Alert Driver Voltage .....	289
Table 119: ODT DC Characteristics .....	290
Table 120: ODT Sensitivity Definitions .....	291
Table 121: ODT Voltage and Temperature Sensitivity .....	291
Table 122: ODT Timing Definitions .....	292
Table 123: Reference Settings for ODT Timing Measurements .....	292
Table 124: DRAM Package Electrical Specifications for x4 and x8 Devices .....	295
Table 125: DRAM Package Electrical Specifications for x16 Devices .....	296
Table 126: Pad Input/Output Capacitance .....	298
Table 127: Thermal Characteristics .....	299
Table 128: Basic I <sub>DD</sub> , I <sub>PP</sub> , and I <sub>DDQ</sub> Measurement Conditions .....	301
Table 129: I <sub>DD0</sub> and I <sub>PP0</sub> Measurement-Loop Pattern <sup>1</sup> .....	305
Table 130: I <sub>DD1</sub> Measurement-Loop Pattern <sup>1</sup> .....	306
Table 131: I <sub>DD2N</sub> , I <sub>DD3N</sub> , and I <sub>PP3P</sub> Measurement-Loop Pattern <sup>1</sup> .....	307
Table 132: I <sub>DD2NT</sub> and I <sub>DDQ2NT</sub> Measurement-Loop Pattern <sup>1</sup> .....	308
Table 133: I <sub>DD4R</sub> and I <sub>DDQ4R</sub> Measurement-Loop Pattern <sup>1</sup> .....	309
Table 134: I <sub>DD4W</sub> Measurement-Loop Pattern <sup>1</sup> .....	310
Table 135: I <sub>DD4Wc</sub> Measurement-Loop Pattern <sup>1</sup> .....	311
Table 136: I <sub>DD5b</sub> Measurement-Loop Pattern <sup>1</sup> .....	312
Table 137: I <sub>DD7</sub> Measurement-Loop Pattern <sup>1</sup> .....	313
Table 138: Timings used for I <sub>DD</sub> , I <sub>PP</sub> , and I <sub>DDQ</sub> Measurement-Loop Patterns .....	314
Table 139: I <sub>DD</sub> , I <sub>PP</sub> , and I <sub>DDQ</sub> Current Limits – Rev. A .....	315
Table 140: I <sub>DD</sub> , I <sub>PP</sub> , and I <sub>DDQ</sub> Current Limits – Rev. B .....	316
Table 141: DDR4-1600 Speed Bins and Operating Conditions .....	319
Table 142: DDR4-1866 Speed Bins and Operating Conditions .....	320
Table 143: DDR4-2133 Speed Bins and Operating Conditions .....	321
Table 144: DDR4-2400 Speed Bins and Operating Conditions .....	322
Table 145: DDR4-2666 Speed Bins and Operating Conditions .....	323
Table 146: DDR4-2933 Speed Bins and Operating Conditions .....	324
Table 147: DDR4-3200 Speed Bins and Operating Conditions .....	326
Table 148: Refresh Parameters by Device Density .....	328
Table 149: Electrical Characteristics and AC Timing Parameters: DDR4-1600 through DDR4-2400 .....	329
Table 150: Electrical Characteristics and AC Timing Parameters .....	341
Table 151: Die Revision Options .....	353
Table 152: Speed Options .....	354
Table 153: Width Options .....	354

## General Notes and Description

### Description

The DDR4 SDRAM is a high-speed dynamic random-access memory internally configured as an eight-bank DRAM for the x16 configuration and as a 16-bank DRAM for the x4 and x8 configurations. The DDR4 SDRAM uses an  $8n$ -prefetch architecture to achieve high-speed operation. The  $8n$ -prefetch architecture is combined with an interface designed to transfer two data words per clock cycle at the I/O pins.

A single READ or WRITE operation for the DDR4 SDRAM consists of a single  $8n$ -bit wide, four-clock data transfer at the internal DRAM core and two corresponding  $n$ -bit wide, one-half-clock-cycle data transfers at the I/O pins. on page

### Industrial Temperature

An industrial temperature (IT) device option requires that the case temperature not exceed below  $-40^{\circ}\text{C}$  or above  $95^{\circ}\text{C}$ . JEDEC specifications require the refresh rate to double when  $T_C$  exceeds  $85^{\circ}\text{C}$ ; this also requires use of the high-temperature self refresh option. Additionally, ODT resistance and the input/output impedance must be derated when operating outside of the commercial temperature range, when  $T_C$  is between  $-40^{\circ}\text{C}$  and  $0^{\circ}\text{C}$ .

### General Notes

- The functionality and the timing specifications discussed in this data sheet are for the DLL enable mode of operation (normal operation), unless specifically stated otherwise.
- Throughout the data sheet, the various figures and text refer to DQs as "DQ." The DQ term is to be interpreted as any and all DQ collectively, unless specifically stated otherwise.
- The terms "\_t" and "\_c" are used to represent the true and complement of a differential signal pair. These terms replace the previously used notation of "#" and/or overbar characters. For example, differential data strobe pair DQS, DQS# is now referred to as DQS\_t, DQS\_c.
- The term "\_n" is used to represent a signal that is active LOW and replaces the previously used "#" and/or overbar characters. For example: CS# is now referred to as CS\_n.
- The terms "DQS" and "CK" found throughout the data sheet are to be interpreted as DQS\_t, DQS\_c and CK\_t, CK\_c respectively, unless specifically stated otherwise.
- Complete functionality may be described throughout the entire document; any page or diagram may have been simplified to convey a topic and may not be inclusive of all requirements.
- Any specific requirement takes precedence over a general statement.
- Any functionality not specifically stated here within is considered undefined, illegal, and not supported, and can result in unknown operation.
- Addressing is denoted as BG[n] for bank group, BA[n] for bank address, and A[n] for row/col address.
- The NOP command is not allowed, except when exiting maximum power savings mode or when entering gear-down mode, and only a DES command should be used.

- Not all features described within this document may be available on the Rev. A (first) version.
- Not all specifications listed are finalized industry standards; best conservative estimates have been provided when an industry standard has not been finalized.
- Although it is implied throughout the specification, the DRAM must be used after  $V_{DD}$  has reached the stable power-on level, which is achieved by toggling CKE at least once every  $8192 \times t_{REFI}$ . However, in the event CKE is fixed HIGH, toggling CS\_n at least once every  $8192 \times t_{REFI}$  is an acceptable alternative. Placing the DRAM into self refresh mode also alleviates the need to toggle CKE.
- Not all features designated in the data sheet may be supported by earlier die revisions due to late definition by JEDEC.

### Definitions of the Device-Pin Signal Level

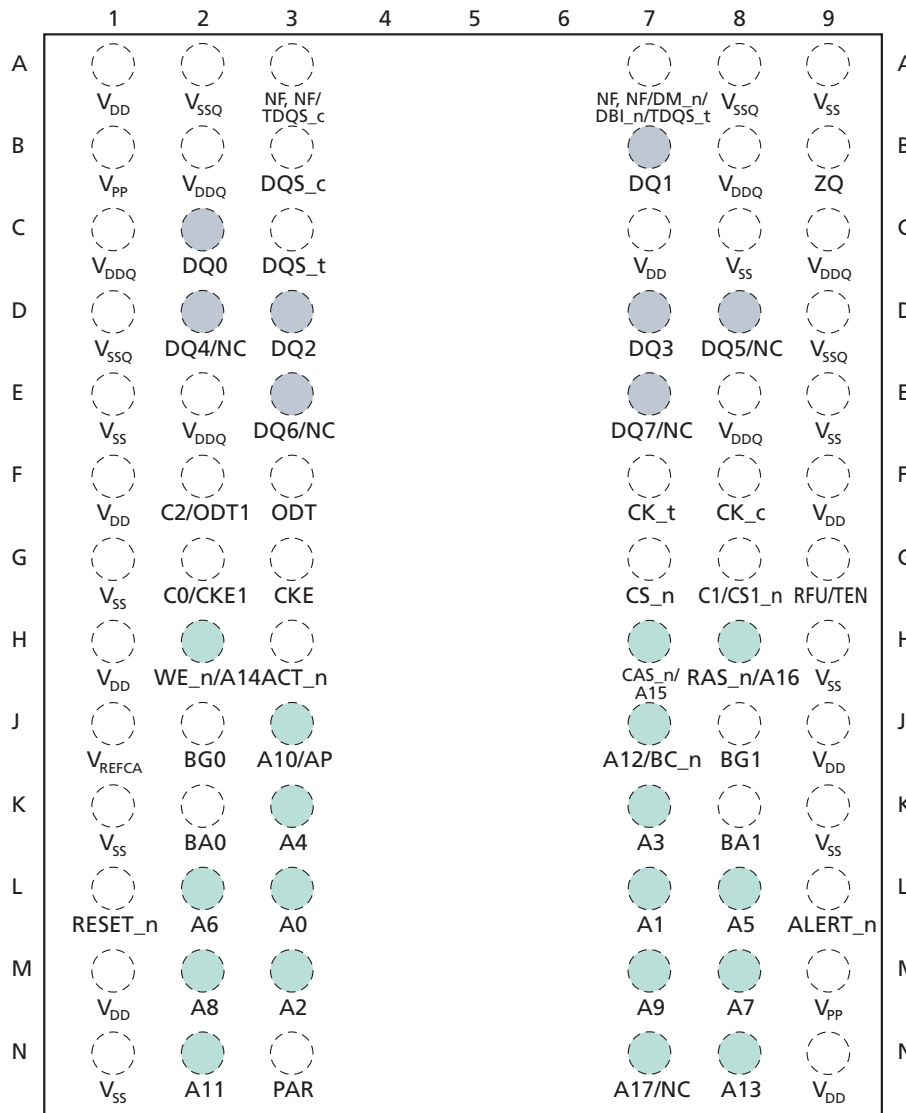
- HIGH: A device pin is driving the logic 1 state.
- LOW: A device pin is driving the logic 0 state.
- High-Z: A device pin is tri-state.
- ODT: A device pin terminates with the ODT setting, which could be terminating or tri-state depending on the mode register setting.

### Definitions of the Bus Signal Level

- HIGH: One device on the bus is HIGH, and all other devices on the bus are either ODT or High-Z. The voltage level on the bus is nominally  $V_{DDQ}$ .
- LOW: One device on the bus is LOW, and all other devices on the bus are either ODT or High-Z. The voltage level on the bus is nominally  $V_{OL(DC)}$  if ODT was enabled, or  $V_{SSQ}$  if High-Z.
- High-Z: All devices on the bus are High-Z. The voltage level on the bus is undefined as the bus is floating.
- ODT: At least one device on the bus is ODT, and all others are High-Z. The voltage level on the bus is nominally  $V_{DDQ}$ .

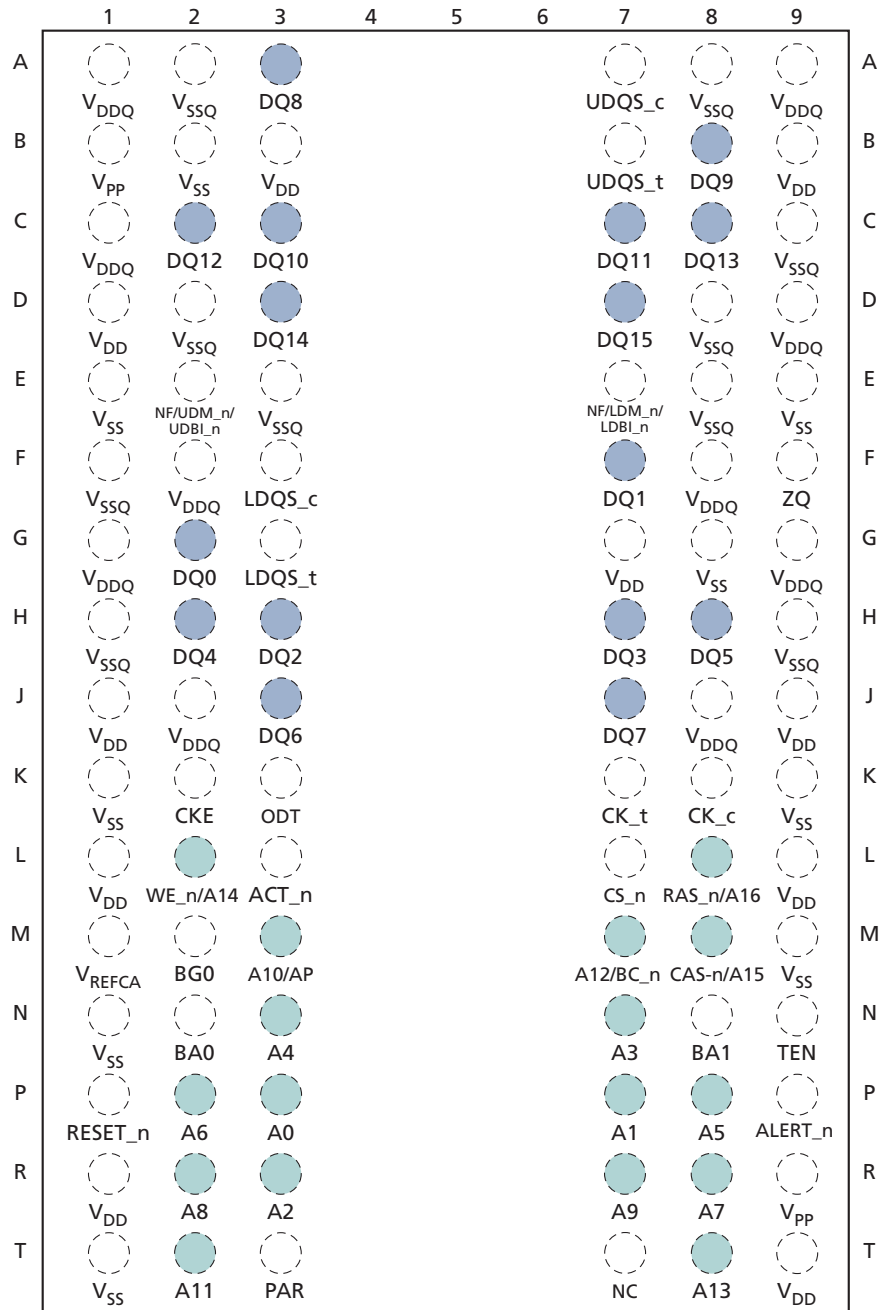
## Ball Assignments

**Figure 1: 78-Ball x4, x8 Ball Assignments**



- Notes:
1. See Ball Descriptions.
  2. A comma "," separates the configuration; a slash "/" defines a selectable function. For example: Ball A7 = NF, NF/DM\_n/DBI\_n/TDQS\_t where NF applies to the x4 configuration only. NF/DM\_n/DBI\_n/TDQS\_t applies to the x8 configuration only and is selectable between NF, DM\_n, DBI\_n, or TDQS\_t via MRS.
  3. Address bits (including bank groups) are density- and configuration-dependent (see Addressing).
  4. G9 may be RFU and not assigned as TEN on some die revisions as TEN is not required on 4Gb x4 and x8 offerings.

**Figure 2: 96-Ball x16 Ball Assignments**



- Notes:
1. See Ball Descriptions.
  2. A slash "/" defines a selectable function. For example: Ball E7 = NF/LDM\_n. If data mask is enabled via the MRS, ball E7 = LDM\_n. If data mask is disabled in the MRS, E7 = NF (no function).
  3. Address bits (including bank groups) are density- and configuration-dependent (see Addressing).

## Ball Descriptions

The pin description table below is a comprehensive list of all possible pins for DDR4 devices. All pins listed may not be supported on the device defined in this data sheet. See the Ball Assignments section to review all pins used on this device.

**Table 3: Ball Descriptions**

Symbol	Type	Description
A[17:0]	Input	<b>Address inputs:</b> Provide the row address for ACTIVATE commands and the column address for READ/WRITE commands to select one location out of the memory array in the respective bank. (A10/AP, A12/BC_n, WE_n/A14, CAS_n/A15, RAS_n/A16 have additional functions, see individual entries in this table.) The address inputs also provide the op-code during the MODE REGISTER SET command. A16 is used on some 8Gb and 16Gb parts, and A17 is only used on some 16Gb parts.
A10/AP	Input	<b>Auto precharge:</b> A10 is sampled during READ and WRITE commands to determine whether auto precharge should be performed to the accessed bank after a READ or WRITE operation. (HIGH = auto precharge; LOW = no auto precharge.) A10 is sampled during a PRECHARGE command to determine whether the PRECHARGE applies to one bank (A10 LOW) or all banks (A10 HIGH). If only one bank is to be precharged, the bank is selected by the bank group and bank addresses.
A12/BC_n	Input	<b>Burst chop:</b> A12/BC_n is sampled during READ and WRITE commands to determine if burst chop (on-the-fly) will be performed. (HIGH = no burst chop; LOW = burst chopped). See the Command Truth Table.
ACT_n	Input	<b>Command input:</b> ACT_n indicates an ACTIVATE command. When ACT_n (along with CS_n) is LOW, the input pins RAS_n/A16, CAS_n/A15, and WE_n/A14 are treated as row address inputs for the ACTIVATE command. When ACT_n is HIGH (along with CS_n LOW), the input pins RAS_n/A16, CAS_n/A15, and WE_n/A14 are treated as normal commands that use the RAS_n, CAS_n, and WE_n signals. See the Command Truth Table.
BA[1:0]	Input	<b>Bank address inputs:</b> Define the bank (within a bank group) to which an ACTIVATE, READ, WRITE, or PRECHARGE command is being applied. Also determines which mode register is to be accessed during a MODE REGISTER SET command.
BG[1:0]	Input	<b>Bank group address inputs:</b> Define the bank group to which a REFRESH, ACTIVATE, READ, WRITE, or PRECHARGE command is being applied. Also determines which mode register is to be accessed during a MODE REGISTER SET command. BG[1:0] are used in the x4 and x8 configurations. BG1 is not used in the x16 configuration.
C0/CKE1, C1/CS1_n, C2/ODT1	Input	<b>Stack address inputs:</b> These inputs are used only when devices are stacked; that is, they are used in 2H, 4H, and 8H stacks for x4 and x8 configurations (these pins are not used in the x16 configuration). DDR4 will support a traditional DDP package, which uses these three signals for control of the second die (CS1_n, CKE1, ODT1). DDR4 is not expected to support a traditional QDP package. For all other stack configurations, such as a 4H or 8H, it is assumed to be a single-load (master/slave) type of configuration where C0, C1, and C2 are used as chip ID selects in conjunction with a single CS_n, CKE, and ODT signal.
CK_t, CK_c	Input	<b>Clock:</b> Differential clock inputs. All address, command, and control input signals are sampled on the crossing of the positive edge of CK_t and the negative edge of CK_c.

**Table 3: Ball Descriptions (Continued)**

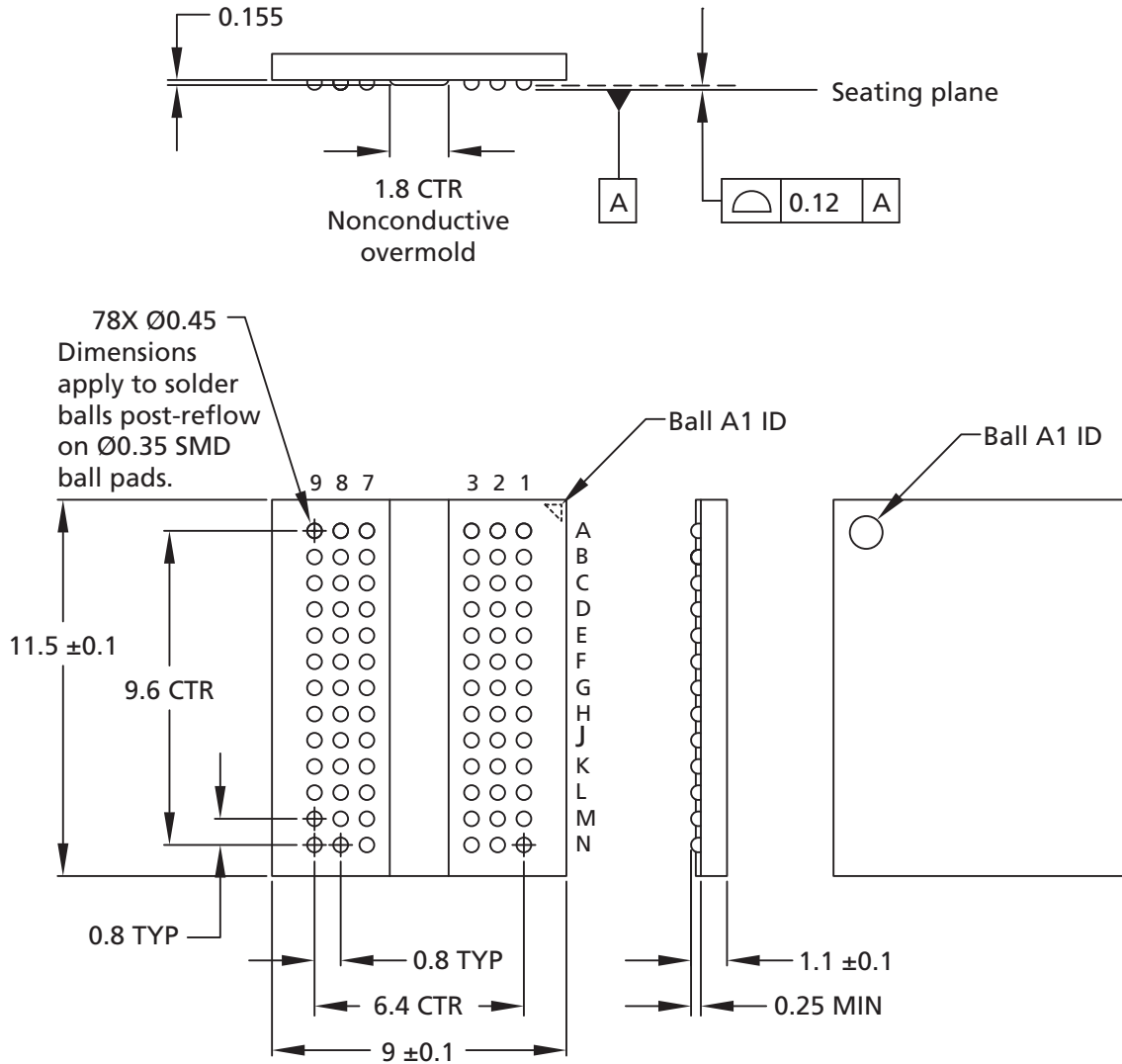
Symbol	Type	Description
CKE	Input	<b>Clock enable:</b> CKE HIGH activates and CKE LOW deactivates the internal clock signals, device input buffers, and output drivers. Taking CKE LOW provides PRECHARGE POWER-DOWN and SELF REFRESH operations (all banks idle), or active power-down (row active in any bank). CKE is asynchronous for self refresh exit. After $V_{REFFCA}$ has become stable during the power-on and initialization sequence, it must be maintained during all operations (including SELF REFRESH). CKE must be maintained HIGH throughout read and write accesses. Input buffers (excluding CK_t, CK_c, ODT, RESET_n, and CKE) are disabled during power-down. Input buffers (excluding CKE and RESET_n) are disabled during self refresh.
CS_n	Input	<b>Chip select:</b> All commands are masked when CS_n is registered HIGH. CS_n provides for external rank selection on systems with multiple ranks. CS_n is considered part of the command code.
DM_n, UDM_n LDM_n	Input	<b>Input data mask:</b> DM_n is an input mask signal for write data. Input data is masked when DM is sampled LOW coincident with that input data during a write access. DM is sampled on both edges of DQS. DM is not supported on x4 configurations. The UDM_n and LDM_n pins are used in the x16 configuration: UDM_n is associated with DQ[15:8]; LDM_n is associated with DQ[7:0]. The DM, DBI, and TDQS functions are enabled by mode register settings. See the Data Mask section.
ODT	Input	<b>On-die termination:</b> ODT (registered HIGH) enables termination resistance internal to the DDR4 SDRAM. When enabled, ODT ( $R_{TT}$ ) is applied only to each DQ, DQS_t, DQS_c, DM_n/DBI_n/TDQS_t, and TDQS_c signal for the x4 and x8 configurations (when the TDQS function is enabled via mode register). For the x16 configuration, $R_{TT}$ is applied to each DQ, DQSU_t, DQSU_c, DQSL_t, DQSL_c, UDM_n, and LDM_n signal. The ODT pin will be ignored if the mode registers are programmed to disable $R_{TT}$ .
PAR	Input	<b>Parity for command and address:</b> This function can be enabled or disabled via the mode register. When enabled, the parity signal covers all command and address inputs, including ACT_n, RAS_n/A16, CAS_n/A15, WE_n/A14, A[17:0], A10/AP, A12/BC_n, BA[1:0], and BG[1:0] with C0, C1, and C2 on 3DS only devices. Control pins NOT covered by the parity signal are CS_n, CKE, and ODT. Unused address pins that are density- and configuration-specific should be treated internally as 0s by the DRAM parity logic. Command and address inputs will have parity check performed when commands are latched via the rising edge of CK_t and when CS_n is LOW.
RAS_n/A16, CAS_n/A15, WE_n/A14	Input	<b>Command inputs:</b> RAS_n/A16, CAS_n/A15, and WE_n/A14 (along with CS_n and ACT_n) define the command and/or address being entered. See the ACT_n description in this table.
RESET_n	Input	<b>Active LOW asynchronous reset:</b> Reset is active when RESET_n is LOW, and inactive when RESET_n is HIGH. RESET_n must be HIGH during normal operation. RESET_n is a CMOS rail-to-rail signal with DC HIGH and LOW at 80% and 20% of $V_{DD}$ (960 mV for DC HIGH and 240 mV for DC LOW).
TEN	Input	<b>Connectivity test mode:</b> TEN is active when HIGH and inactive when LOW. TEN must be LOW during normal operation. TEN is a CMOS rail-to-rail signal with DC HIGH and LOW at 80% and 20% of $V_{DD}$ (960mV for DC HIGH and 240mV for DC LOW).

**Table 3: Ball Descriptions (Continued)**

Symbol	Type	Description
DQ	I/O	<b>Data input/output:</b> Bidirectional data bus. DQ represents DQ[3:0], DQ[7:0], and DQ[15:0] for the x4, x8, and x16 configurations, respectively. If write CRC is enabled via mode register, the write CRC code is added at the end of data burst. Any one or all of DQ0, DQ1, DQ2, and DQ3 may be used to monitor the internal $V_{REF}$ level during test via mode register setting MR[4] A[4] = HIGH, training times change when enabled. During this mode, the $R_{TT}$ value should be set to High-Z. This measurement is for verification purposes and is NOT an external voltage supply pin.
DBI_n, UDBI_n, LDBI_n	I/O	<b>DBI input/output:</b> Data bus inversion. DBI_n is an input/output signal used for data bus inversion in the x8 configuration. UDBI_n and LDBI_n are used in the x16 configuration; UDBI_n is associated with DQ[15:8], and LDBI_n is associated with DQ[7:0]. The DBI feature is not supported on the x4 configuration. DBI can be configured for both READ (output) and WRITE (input) operations depending on the mode register settings. The DM, DBI, and TDQS functions are enabled by mode register settings. See the Data Bus Inversion section.
DQS_t, DQS_c, DQSU_t, DQSU_c, DQSL_t, DQSL_c	I/O	<b>Data strobe:</b> Output with READ data, input with WRITE data. Edge-aligned with READ data, centered-aligned with WRITE data. For the x16, DQSL corresponds to the data on DQ[7:0]; DQSU corresponds to the data on DQ[15:8]. For the x4 and x8 configurations, DQS corresponds to the data on DQ[3:0] and DQ[7:0], respectively. DDR4 SDRAM supports a differential data strobe only and does not support a single-ended data strobe.
ALERT_n	Output	<b>Alert output:</b> This signal allows the DRAM to indicate to the system's memory controller that a specific alert or event has occurred. Alerts will include the command/address parity error and the CRC data error when either of these functions is enabled in the mode register.
TDQS_t, TDQS_c	Output	<b>Termination data strobe:</b> TDQS_t and TDQS_c are used by x8 DRAMs only. When enabled via the mode register, the DRAM will enable the same $R_{TT}$ termination resistance on TDQS_t and TDQS_c that is applied to DQS_t and DQS_c. When the TDQS function is disabled via the mode register, the DM/TDQS_t pin will provide the DATA MASK (DM) function, and the TDQS_c pin is not used. The TDQS function must be disabled in the mode register for both the x4 and x16 configurations. The DM function is supported only in x8 and x16 configurations.
$V_{DD}$	Supply	<b>Power supply:</b> 1.2V $\pm$ 0.060V.
$V_{DDQ}$	Supply	<b>DQ power supply:</b> 1.2V $\pm$ 0.060V.
$V_{PP}$	Supply	<b>DRAM activating power supply:</b> 2.5V $-0.125V/+0.250V$ .
$V_{REFCA}$	Supply	Reference voltage for control, command, and address pins.
$V_{SS}$	Supply	Ground.
$V_{SSQ}$	Supply	DQ ground.
ZQ	Reference	<b>Reference ball for ZQ calibration:</b> This ball is tied to an external 240 $\Omega$ resistor (RZQ), which is tied to $V_{SSQ}$ .
RFU	–	Reserved for future use.
NC	–	<b>No connect:</b> No internal electrical connection is present.
NF	–	<b>No function:</b> May have internal connection present but has no function.

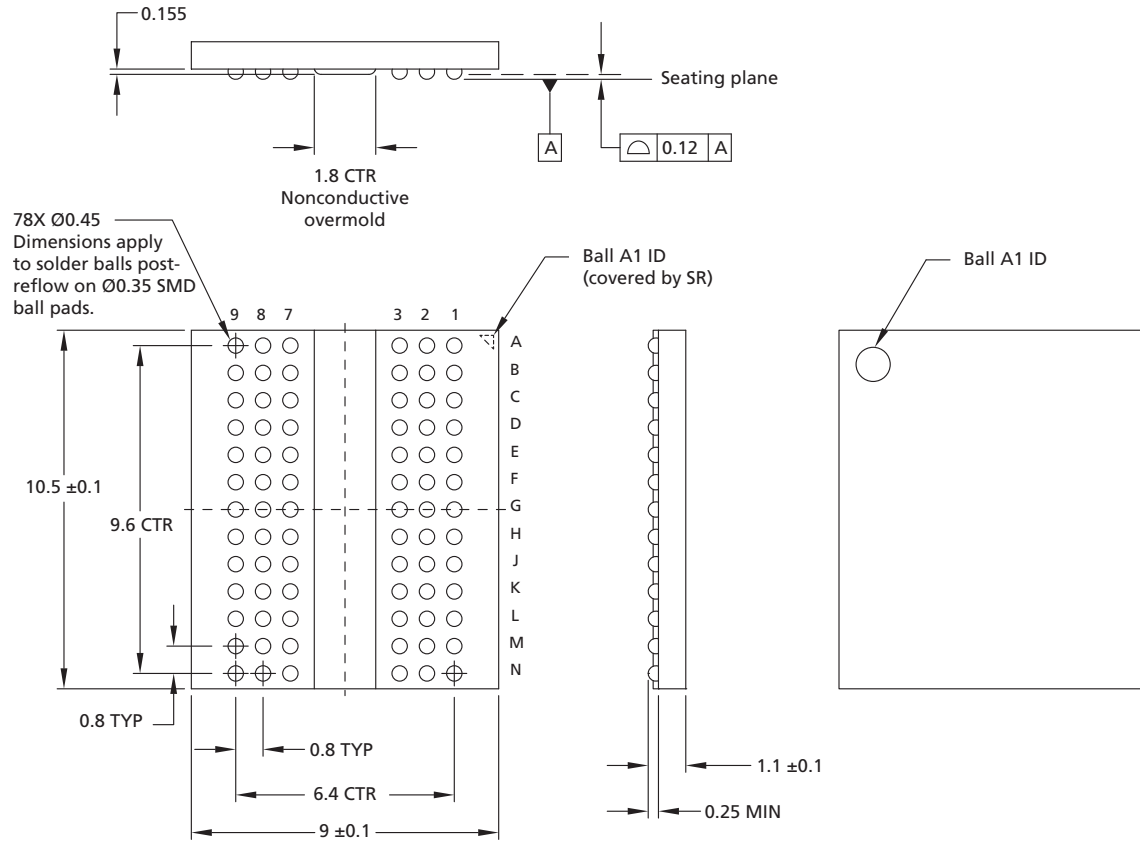
## Package Dimensions

Figure 3: 78-Ball FBGA – x4, x8 "HX"



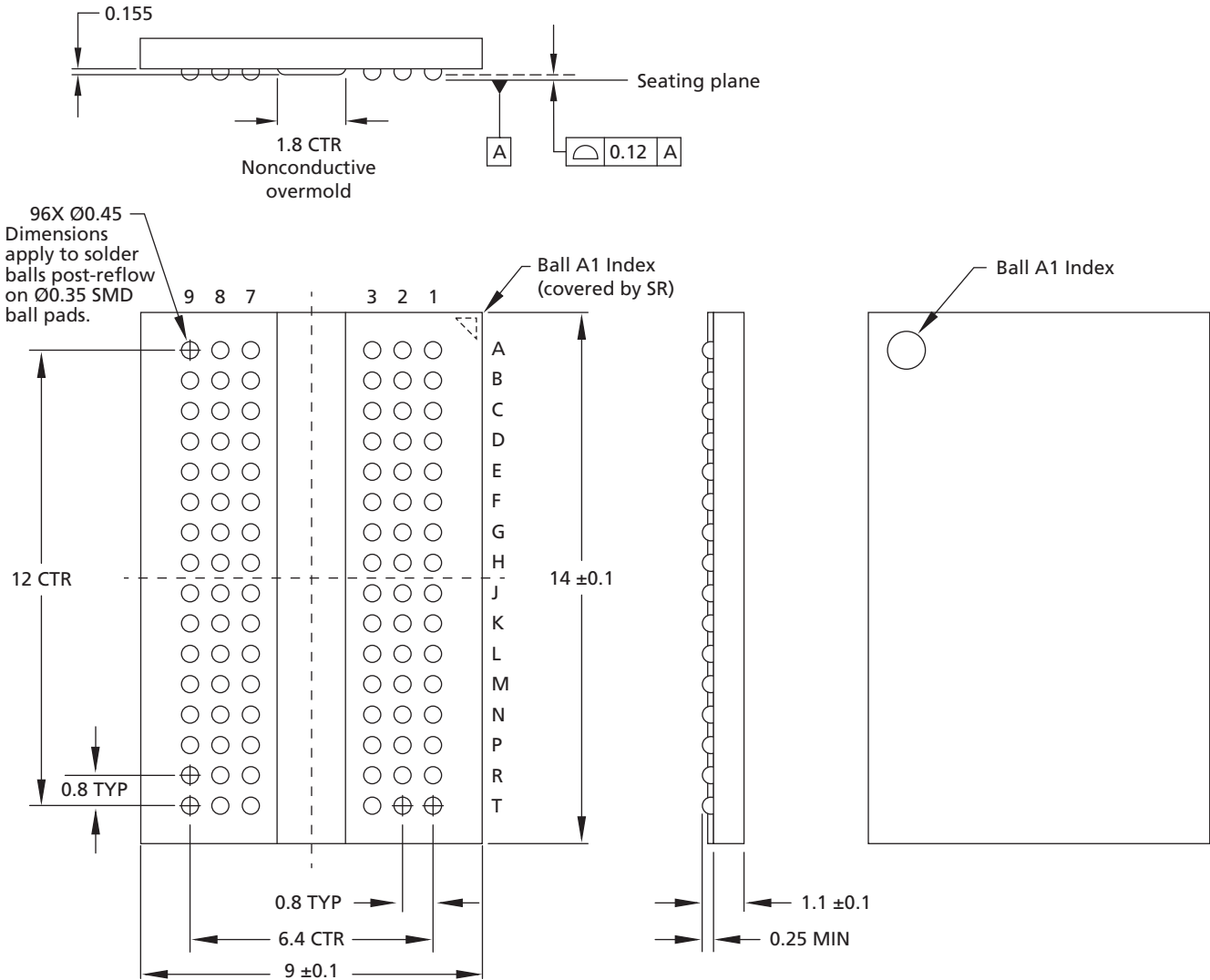
- Notes: 1. All dimensions are in millimeters.  
2. Solder ball material: SAC305 (Pb-free 96.5% Sn, 3% Ag, 0.5% Cu).

**Figure 4: 78-Ball FBGA – x4, x8 "RH"**



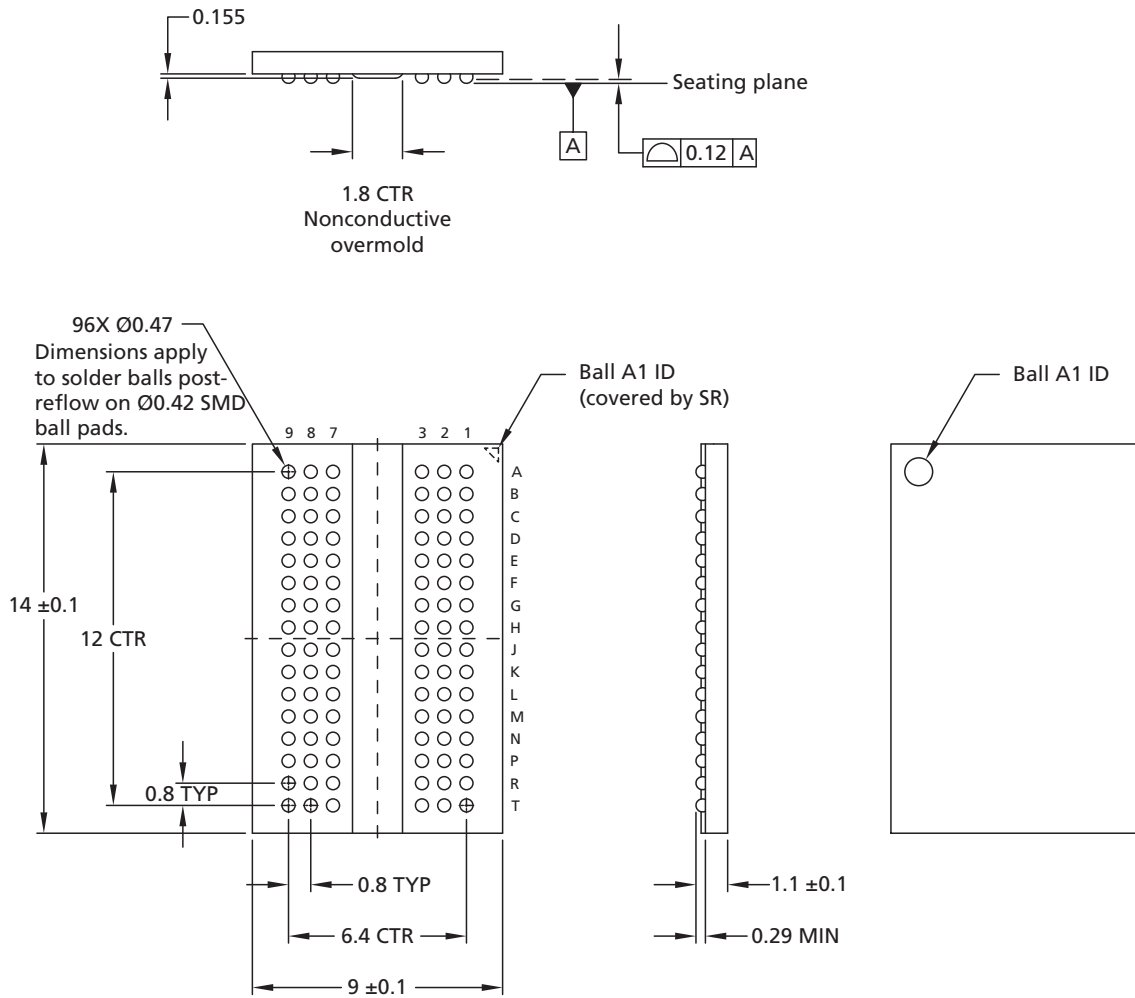
- Notes: 1. All dimensions are in millimeters.  
2. Solder ball material: SAC305 (Pb-free 96.5% Sn, 3% Ag, 0.5% Cu).

**Figure 5: 96-Ball FBGA – x16 "HA"**



- Notes: 1. All dimensions are in millimeters.  
2. Solder ball material: SAC305 (Pb-free 96.5% Sn, 3% Ag, 0.5% Cu).

**Figure 6: 96-Ball FBGA – x16 "GE"**

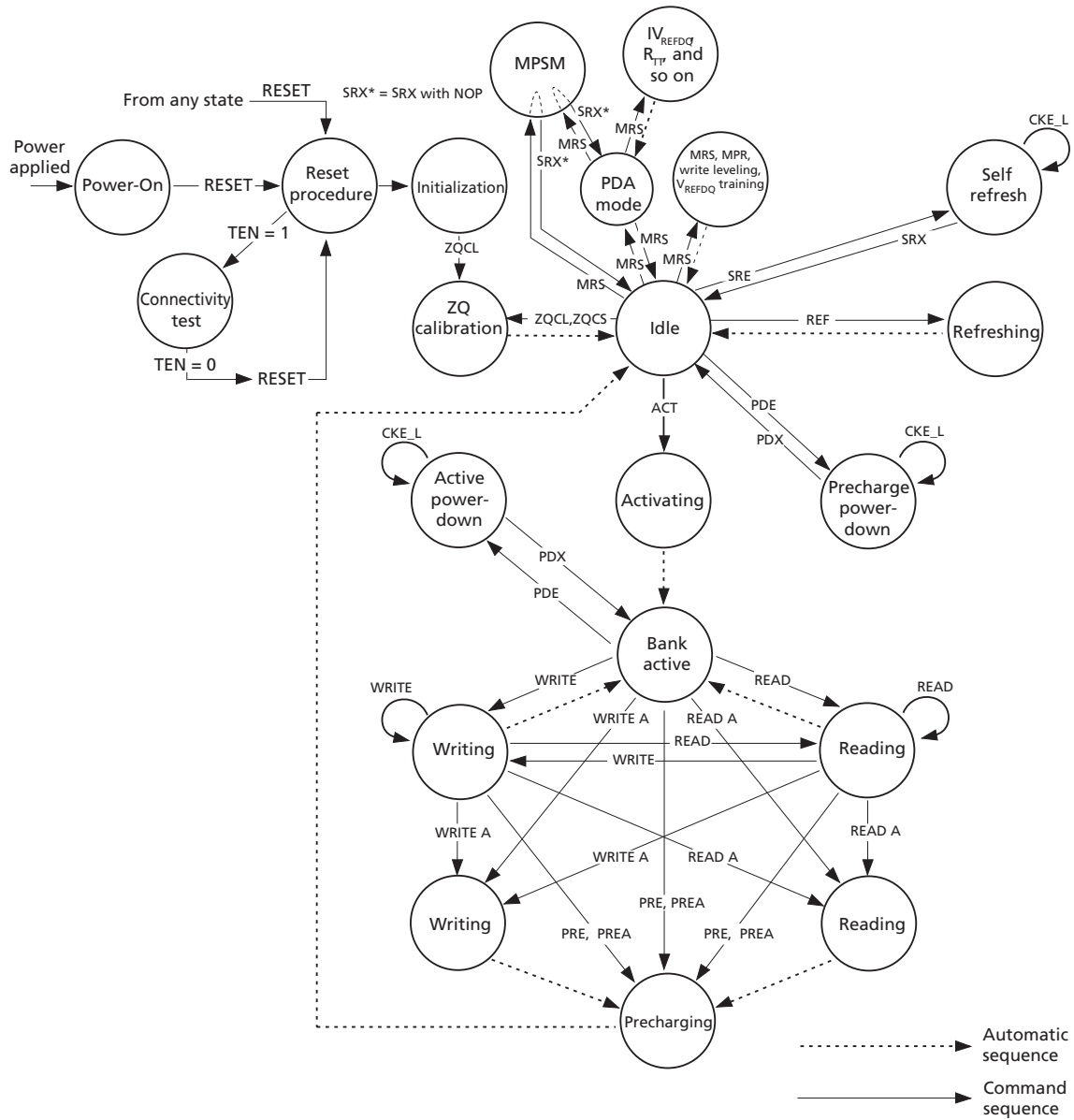


- Notes: 1. All dimensions are in millimeters.  
2. Solder ball material: SAC305 (Pb-free 96.5% Sn, 3% Ag, 0.5% Cu).

## State Diagram

This simplified state diagram provides an overview of the possible state transitions and the commands to control them. Situations involving more than one bank, the enabling or disabling of on-die termination, and some other events are not captured in full detail.

Figure 7: Simplified State Diagram



**Table 4: State Diagram Command Definitions**

<b>Command</b>	<b>Description</b>
ACT	Active
MPR	Multipurpose register
MRS	Mode register set
PDE	Enter power-down
PDX	Exit power-down
PRE	Precharge
PREA	Precharge all
READ	RD, RDS4, RDS8
READ A	RDA, RDAS4, RDAS8
REF	Refresh, fine granularity refresh
RESET	Start reset procedure
SRE	Self refresh entry
SRX	Self refresh exit
TEN	Boundary scan mode enable
WRITE	WR, WRS4, WRS8 with/without CRC
WRITE A	WRA, WRAS4, WRAS8 with/without CRC
ZQCL	ZQ calibration long
ZQCS	ZQ calibration short

Note: 1. See the Command Truth Table for more details.

## Functional Description

The DDR4 SDRAM is a high-speed dynamic random-access memory internally configured as sixteen banks (4 bank groups with 4 banks for each bank group) for x4/x8 devices, and as eight banks for each bank group (2 bank groups with 4 banks each) for x16 devices. The device uses double data rate (DDR) architecture to achieve high-speed operation. DDR4 architecture is essentially an  $8n$ -prefetch architecture with an interface designed to transfer two data words per clock cycle at the I/O pins. A single read or write access for a device module effectively consists of a single  $8n$ -bit-wide, four-clock-cycle-data transfer at the internal DRAM core and eight corresponding  $n$ -bit-wide, one-half-clock-cycle data transfers at the I/O pins.

Read and write accesses to the device are burst-oriented. Accesses start at a selected location and continue for a burst length of eight or a chopped burst of four in a programmed sequence. Operation begins with the registration of an ACTIVE command, which is then followed by a READ or WRITE command. The address bits registered coincident with the ACTIVE command are used to select the bank and row to be accessed (BG[1:0] select the bank group for x4/x8, and BG0 selects the bank group for x16; BA[1:0] select the bank, and A[17:0] select the row. See the Addressing section for more details). The address bits registered coincident with the READ or WRITE command are used to select the starting column location for the burst operation, determine if the auto PRECHARGE command is to be issued (via A10), and select BC4 or BL8 mode on-the-fly (OTF) (via A12) if enabled in the mode register.

Prior to normal operation, the device must be powered up and initialized in a predefined manner. The following sections provide detailed information covering device reset and initialization, register definition, command descriptions, and device operation.

NOTE: The use of the NOP command is allowed only when exiting maximum power saving mode or when entering gear-down mode.

## RESET and Initialization Procedure

To ensure proper device function, the power-up and reset initialization default values for the following mode register (MR) settings are defined as:

- Gear-down mode (MR3 A[3]): 0 = 1/2 rate
- Per-DRAM addressability (MR3 A[4]): 0 = disable
- Maximum power-saving mode (MR4 A[1]): 0 = disable
- CS to command/address latency (MR4 A[8:6]): 000 = disable
- CA parity latency mode (MR5 A[2:0]): 000 = disable

## Power-Up and Initialization Sequence

The following sequence is required for power-up and initialization:

1. Apply power (RESET<sub>n</sub> and TEN should be maintained below  $0.2 \times V_{DD}$  while supplies ramp up; all other inputs may be undefined). When supplies have ramped to a valid stable level, RESET<sub>n</sub> must be maintained below  $0.2 \times V_{DD}$  for a minimum of  $t_{PW\_RESET\_L}$  and TEN must be maintained below  $0.2 \times V_{DD}$  for a minimum of 700 $\mu$ s. CKE is pulled LOW anytime before RESET<sub>n</sub> is de-asserted (minimum time of 10ns). The power voltage ramp time between 300mV to  $V_{DD,min}$  must be no greater than 200ms, and during the ramp,  $V_{DD}$  must be greater than or equal to  $V_{DDQ}$  and  $(V_{DD} - V_{DDQ}) < 0.3V$ .  $V_{PP}$  must ramp at the same time or before  $V_{DD}$ , and  $V_{PP}$  must be equal to or higher than  $V_{DD}$  at all times. After  $V_{DD}$  has ramped and reached the stable level, the initialization sequence must be started within 64ms.

During power-up, either of the following conditions may exist and must be met:

- Condition A:
    - Apply  $V_{PP}$  without any slope reversal before or at the same time as  $V_{DD}$  and  $V_{DDQ}$ .
    - $V_{DD}$  and  $V_{DDQ}$  are driven from a single-power converter output and apply  $V_{DD}/V_{DDQ}$  without any slope reversal before or at the same time as  $V_{TT}$  and  $V_{REFCA}$ .
    - The voltage levels on all balls other than  $V_{DD}$ ,  $V_{DDQ}$ ,  $V_{SS}$ , and  $V_{SSQ}$  must be less than or equal to  $V_{DDQ}$  and  $V_{DD}$  on one side and must be greater than or equal to  $V_{SSQ}$  and  $V_{SS}$  on the other side.
    - $V_{TT}$  is limited to 0.76V MAX when the power ramp is complete.
    - $V_{REFCA}$  tracks  $V_{DD}/2$ .
  - Condition B:
    - Apply  $V_{PP}$  without any slope reversal before or at the same time as  $V_{DD}$ .
    - Apply  $V_{DD}$  without any slope reversal before or at the same time as  $V_{DDQ}$ .
    - Apply  $V_{DDQ}$  without any slope reversal before or at the same time as  $V_{TT}$  and  $V_{REFCA}$ .
    - The voltage levels on all pins other than  $V_{PP}$ ,  $V_{DD}$ ,  $V_{DDQ}$ ,  $V_{SS}$ , and  $V_{SSQ}$  must be less than or equal to  $V_{DDQ}$  and  $V_{DD}$  on one side and must be larger than or equal to  $V_{SSQ}$  and  $V_{SS}$  on the other side.
2. After RESET<sub>n</sub> is de-asserted, wait for another 500 $\mu$ s until CKE becomes active. During this time, the device will start internal state initialization; this will be done independently of external clocks. A reasonable attempt was made in the design to power up with the following default MR settings: gear-down mode (MR3 A[3]): 0 = 1/2 rate; per-DRAM addressability (MR3 A[4]): 0 = disable; maximum power-down

(MR4 A[1]): 0 = disable; CS to command/address latency (MR4 A[8:6]): 000 = disable; CA parity latency mode (MR5 A[2:0]): 000 = disable. However, it should be assumed that at power up the MR settings are undefined and should be programmed as shown below.

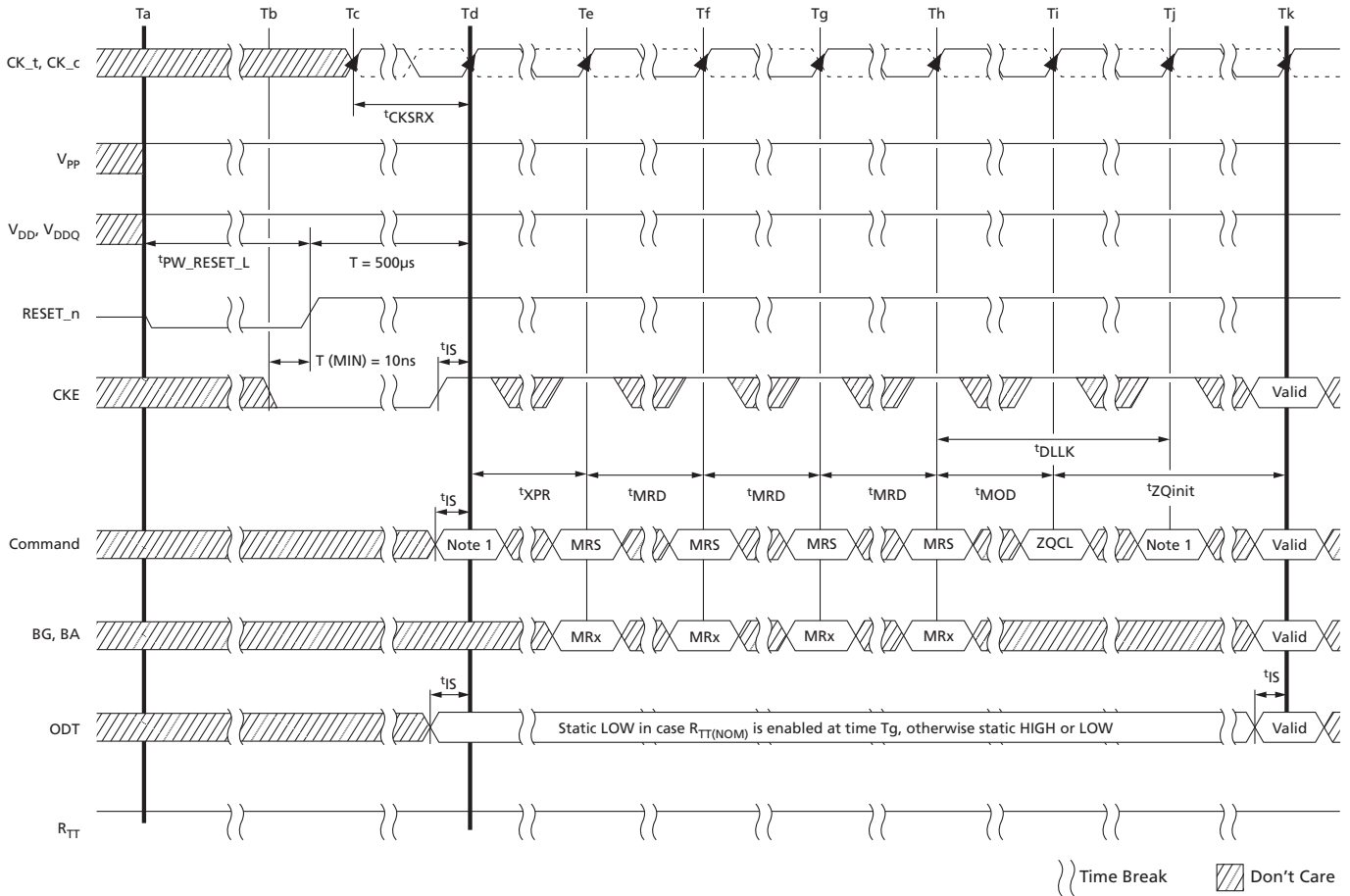
3. Clocks (CK<sub>t</sub>, CK<sub>c</sub>) need to be started and stabilized for at least 10ns or 5<sup>t</sup>CK (whichever is larger) before CKE goes active. Because CKE is a synchronous signal, the corresponding setup time to clock (<sup>t</sup>IS) must be met. Also, a DESELECT command must be registered (with <sup>t</sup>IS setup time to clock) at clock edge T<sub>d</sub>. After the CKE is registered HIGH after RESET, CKE needs to be continuously registered HIGH until the initialization sequence is finished, including expiration of <sup>t</sup>DLLK and <sup>t</sup>ZQ<sub>INIT</sub>.
4. The device keeps its ODT in High-Z state as long as RESET<sub>n</sub> is asserted. Further, the SDRAM keeps its ODT in High-Z state after RESET<sub>n</sub> de-assertion until CKE is registered HIGH. The ODT input signal may be in an undefined state until <sup>t</sup>IS before CKE is registered HIGH. When CKE is registered HIGH, the ODT input signal may be statically held either LOW or HIGH. If R<sub>TT(NOM)</sub> is to be enabled in MR1, the ODT input signal must be statically held LOW. In all cases, the ODT input signal remains static until the power-up initialization sequence is finished, including the expiration of <sup>t</sup>DLLK and <sup>t</sup>ZQ<sub>INIT</sub>.
5. After CKE is registered HIGH, wait a minimum of RESET CKE EXIT time, <sup>t</sup>XPR, before issuing the first MRS command to load mode register (<sup>t</sup>XPR = MAX(<sup>t</sup>XS; 5 × <sup>t</sup>CK)).
6. Issue MRS command to load MR3 with all application settings, wait <sup>t</sup>MRD.
7. Issue MRS command to load MR6 with all application settings, wait <sup>t</sup>MRD.
8. Issue MRS command to load MR5 with all application settings, wait <sup>t</sup>MRD.
9. Issue MRS command to load MR4 with all application settings, wait <sup>t</sup>MRD.
10. Issue MRS command to load MR2 with all application settings, wait <sup>t</sup>MRD.
11. Issue MRS command to load MR1 with all application settings, wait <sup>t</sup>MRD.
12. Issue MRS command to load MR0 with all application settings, wait <sup>t</sup>MOD.
13. Issue a ZQCL command to start ZQ calibration.
14. Wait for <sup>t</sup>DLLK and <sup>t</sup>ZQ<sub>INIT</sub> to complete.
15. The device will be ready for normal operation.

A stable valid V<sub>DD</sub> level is a set DC level (0 Hz to 20 MHz) and must be no less than V<sub>DD,min</sub> and no greater than V<sub>DD,max</sub>. If the set DC level is altered anytime after initialization, the DLL reset and calibrations must be performed again after the new set DC level is stable. AC noise of ±60mV (greater than 20 MHz) is allowed on V<sub>DD</sub> provided the noise doesn't alter V<sub>DD</sub> to less than V<sub>DD,min</sub> or greater than V<sub>DD,max</sub>.

A stable valid V<sub>DDQ</sub> level is a set DC level (0 Hz to 20 MHz) and must be no less than V<sub>DDQ,min</sub> and no greater than V<sub>DDQ,max</sub>. If the set DC level is altered anytime after initialization, the DLL reset and calibrations must be performed again after the new set DC level is stable. AC noise of ±60mV (greater than 20 MHz) is allowed on V<sub>DDQ</sub> provided the noise doesn't alter V<sub>DDQ</sub> to less than V<sub>DDQ,min</sub> or greater than V<sub>DDQ,max</sub>.

A stable valid V<sub>PP</sub> level is a set DC level (0 Hz to 20 MHz) and must be no less than V<sub>PP,min</sub> and no greater than V<sub>PP,max</sub>. If the set DC level is altered anytime after initialization, the DLL reset and calibrations must be performed again after the new set DC level is stable. AC noise of ±120mV (greater than 20 MHz) is allowed on V<sub>PP</sub> provided the noise doesn't alter V<sub>PP</sub> to less than V<sub>PP,min</sub> or greater than V<sub>PP,max</sub>.

**Figure 8: RESET and Initialization Sequence at Power-On Ramping**



- Notes:
1. From time point Td until Tk, a DES command must be applied between MRS and ZQCL commands.
  2. MRS commands must be issued to all mode registers that have defined settings.
  3. In general, there is no specific sequence for setting the MRS locations (except for dependent or co-related features, such as ENABLE DLL in MR1 prior to RESET DLL in MR0, for example).
  4. TEN is not shown; however, it is assumed to be held LOW.

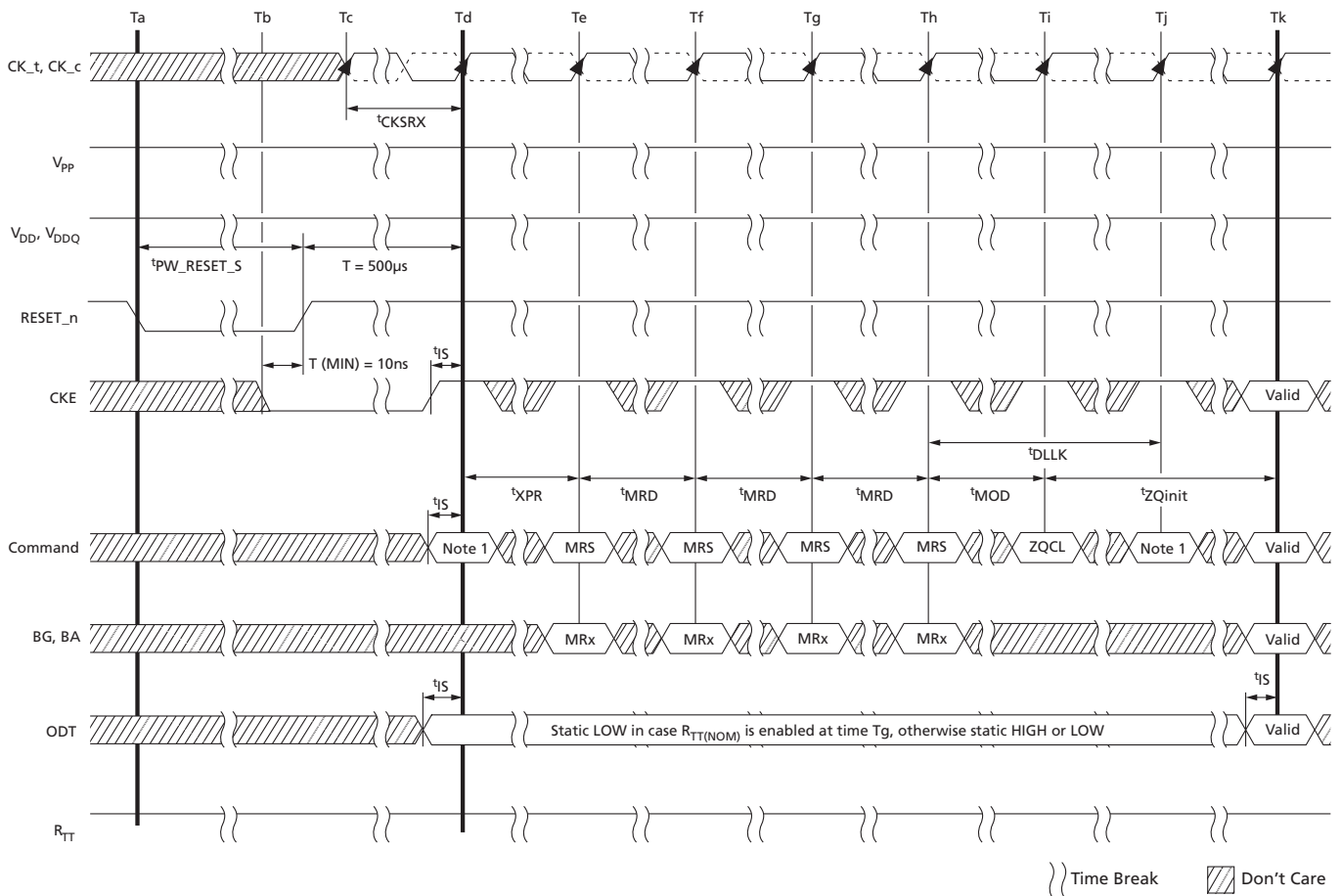
## RESET Initialization with Stable Power Sequence

The following sequence is required for RESET at no power interruption initialization:

1. Assert RESET\_n below  $0.2 \times V_{DD}$  any time reset is needed (all other inputs may be undefined). RESET must be maintained for a minimum of 100ns. CKE is pulled LOW before RESET\_n is de-asserted (minimum time 10ns).
2. Follow Steps 2 to 7 in the Reset and Initialization Sequence at Power-on Ramping procedure.

When the reset sequence is complete, all counters except the refresh counters have been reset and the device is ready for normal operation.

**Figure 9: RESET Procedure at Power Stable Condition**



- Notes:
1. From time point Td until Tk, a DES command must be applied between MRS and ZQCL commands.
  2. MRS commands must be issued to all mode registers that have defined settings.
  3. In general, there is no specific sequence for setting the MRS locations (except for dependent or co-related features, such as ENABLE DLL in MR1 prior to RESET DLL in MR0, for example).
  4. TEN is not shown; however, it is assumed to be held LOW.

## Uncontrolled Power-Down Sequence

In the event of an uncontrolled ramping down of  $V_{PP}$  supply,  $V_{PP}$  is allowed to be less than  $V_{DD}$  provided the following conditions are met:

- Condition A:  $V_{PP}$  and  $V_{DD}/V_{DDQ}$  are ramping down (as part of turning off) from normal operating levels.
- Condition B: The amount that  $V_{PP}$  may be less than  $V_{DD}/V_{DDQ}$  is less than or equal to 500mV.
- Condition C: The time  $V_{PP}$  may be less than  $V_{DD}$  is  $\leq 10$ ms per occurrence with a total accumulated time in this state  $\leq 100$ ms.
- Condition D: The time  $V_{PP}$  may be less than 2.0V and above  $V_{SS}$  while turning off is  $\leq 15$ ms per occurrence with a total accumulated time in this state  $\leq 150$ ms.

## Programming Mode Registers

For application flexibility, various functions, features, and modes are programmable in seven mode registers ( $MR_n$ ) provided by the device as user defined variables that must be programmed via a MODE REGISTER SET (MRS) command. Because the default values of the mode registers are not defined, contents of mode registers must be fully initialized and/or re-initialized; that is, they must be written after power-up and/or reset for proper operation. The contents of the mode registers can be altered by re-executing the MRS command during normal operation. When programming the mode registers, even if the user chooses to modify only a sub-set of the MRS fields, all address fields within the accessed mode register must be redefined when the MRS command is issued. MRS and DLL RESET commands do not affect array contents, which means these commands can be executed any time after power-up without affecting the array contents.

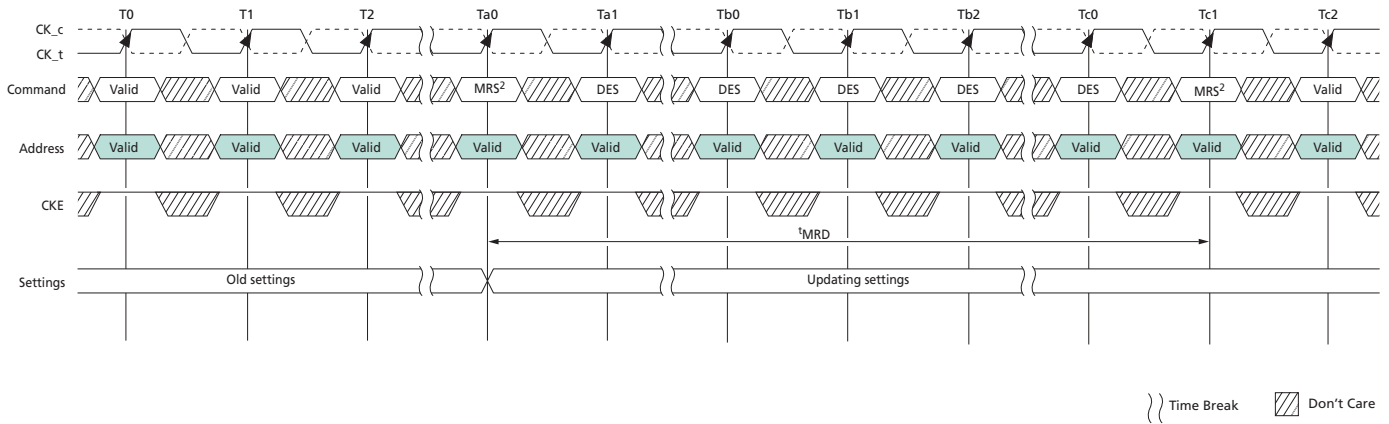
The MRS command cycle time,  $t_{MRD}$ , is required to complete the WRITE operation to the mode register and is the minimum time required between the two MRS commands shown in the  $t_{MRD}$  Timing figure.

Some of the mode register settings affect address/command/control input functionality. In these cases, the next MRS command can be allowed when the function being updated by the current MRS command is completed. These MRS commands don't apply  $t_{MRD}$  timing to the next MRS command; however, the input cases have unique MR setting procedures, so refer to individual function descriptions:

- Gear-down mode
- Per-DRAM addressability
- Maximum power saving mode
- CS to command/address latency
- CA parity latency mode
- $V_{REFDQ}$  training value
- $V_{REFDQ}$  training mode
- $V_{REFDQ}$  training range

Some mode register settings may not be supported because they are not required by certain speed bins.

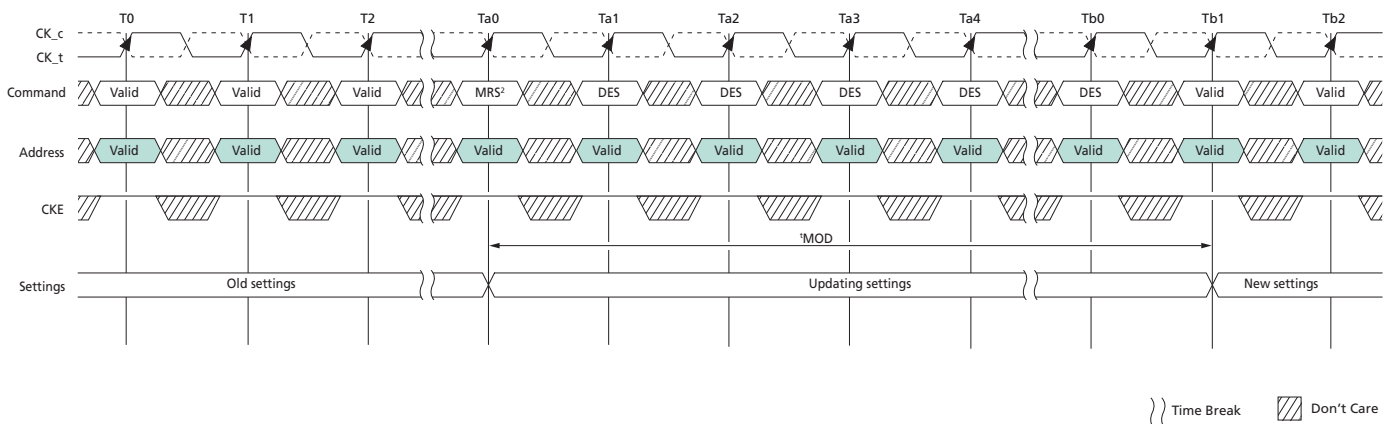
**Figure 10:  $t^{\text{MRD}}$  Timing**



- Notes:
1. This timing diagram depicts CA parity mode "disabled" case.
  2.  $t^{\text{MRD}}$  applies to all MRS commands with the following exceptions:  
 Gear-down mode  
 CA parity mode  
 CAL mode  
 Per-DRAM addressability mode  
 $V_{\text{REFDQ}}$  training value,  $V_{\text{REFDQ}}$  training mode, and  $V_{\text{REFDQ}}$  training range

The MRS command to nonMRS command delay,  $t^{\text{MOD}}$ , is required for the DRAM to update features, except DLL RESET.  $t^{\text{MOD}}$  is the minimum time required from an MRS command to a nonMRS command, excluding DES, as shown in the  $t^{\text{MOD}}$  Timing figure.

**Figure 11:  $t^{\text{MOD}}$  Timing**



- Notes:
1. This timing diagram depicts CA parity mode "disabled" case.
  2.  $t^{\text{MOD}}$  applies to all MRS commands with the following exceptions:  
 DLL enable, Gear-down mode  
 $V_{\text{REFDQ}}$  training value, internal  $V_{\text{REF}}$  training monitor,  $V_{\text{REFDQ}}$  training mode, and  $V_{\text{REFDQ}}$  training range  
 Maximum power savings mode, Per-DRAM addressability mode, and CA parity mode

The mode register contents can be changed using the same command and timing requirements during normal operation as long as the device is in idle state; that is, all banks are in the precharged state with  $t_{RP}$  satisfied, all data bursts are completed, and CKE is HIGH prior to writing into the mode register. If the  $R_{TT(NOM)}$  feature is enabled in the mode register prior to and/or after an MRS command, the ODT signal must continuously be registered LOW, ensuring  $R_{TT}$  is in an off state prior to the MRS command. The ODT signal may be registered HIGH after  $t_{MOD}$  has expired. If the  $R_{TT(NOM)}$  feature is disabled in the mode register prior to and after an MRS command, the ODT signal can be registered either LOW or HIGH before, during, and after the MRS command. The mode registers are divided into various fields depending on functionality and modes.

In some mode register setting cases, function updating takes longer than  $t_{MOD}$ . This type of MRS does not apply  $t_{MOD}$  timing to the next valid command, excluding DES. These MRS command input cases have unique MR setting procedures, so refer to individual function descriptions.

## Mode Register 0

Mode register 0 (MR0) controls various device operating modes as shown in the following register definition table. Not all settings listed may be available on a die; only settings required for speed bin support are available. MR0 is written by issuing the MRS command while controlling the states of the BG<sub>x</sub>, BA<sub>x</sub>, and A<sub>x</sub> address pins. The mapping of address pins during the MRS command is shown in the following MR0 Register Definition table.

**Table 5: Address Pin Mapping**

Address bus	BG1	BG0	BA1	BA0	A17	RAS_n	CAS_n	WE_n	A13	A12	A11	A10	A9	A8	A7	A6	A5	A4	A3	A2	A1	A0
Mode register	21	20	19	18	17	–	–	–	13	12	11	10	9	8	7	6	5	4	3	2	1	0

Note: 1. RAS<sub>n</sub>, CAS<sub>n</sub>, and WE<sub>n</sub> must be LOW during MODE REGISTER SET command.

**Table 6: MR0 Register Definition**

Mode Register	Description
21	<b>RFU</b> 0 = Must be programmed to 0 1 = Reserved
20:18	<b>MR select</b> <b>000 = MR0</b> 001 = MR1 010 = MR2 011 = MR3 100 = MR4 101 = MR5 110 = MR6 111 = DNU
17	<b>N/A on 4Gb and 8Gb, RFU</b> 0 = Must be programmed to 0 1 = Reserved
13,11:9	<b>WR (WRITE recovery)/RTP (READ-to-PRECHARGE)</b> 0000 = 10 / 5 clocks <sup>1</sup> 0001 = 12 / 6 clocks 0010 = 14 / 7 clocks <sup>1</sup> 0011 = 16 / 8 / clocks 0100 = 18 / 9 clocks <sup>1</sup> 0101 = 20 / 10 clocks 0110 = 24 / 12 clocks 0111 = 22 / 11 clocks <sup>1</sup> 1000 = 26 / 13 clocks <sup>1</sup> 1001 through 1111 = Reserved

**Table 6: MR0 Register Definition (Continued)**

Mode Register	Description
8	<b>DLL reset</b> 0 = No 1 = Yes
7	<b>Test mode (TM) – Manufacturer use only</b> 0 = Normal operating mode, must be programmed to 0
12, 6:4, 2	<b>CAS latency (CL) – Delay in clock cycles from the internal READ command to first data-out</b> 00000 = 9 clocks <sup>1</sup> 00001 = 10 clocks 00010 = 11 clocks <sup>1</sup> 00011 = 12 clocks 00100 = 13 clocks <sup>1</sup> 00101 = 14 clocks 00110 = 15 clocks <sup>1</sup> 00111 = 16 clocks 01000 = 18 clocks 01001 = 20 clocks 01010 = 22 clocks 01011 = 24 clocks 01100 = 23 clocks <sup>1</sup> 01101 = 17 clocks <sup>1</sup> 01110 = 19 clocks <sup>1</sup> 01111 = 21 clocks <sup>1</sup> 10000 = 25 clocks (3DS use only) 10001 = 26 clocks 10010 = 27 clocks (3DS use only) 10011 = 28 clocks 10100 = 29 clocks <sup>1</sup> 10101 = 30 clocks 10110 = 31 clocks <sup>1</sup> 10111 = 32 clocks
3	<b>Burst type (BT) – Data burst ordering within a READ or WRITE burst access</b> 0 = Nibble sequential 1 = Interleave
1:0	<b>Burst length (BL) – Data burst size associated with each read or write access</b> 00 = BL8 (fixed) 01 = BC4 or BL8 (on-the-fly) 10 = BC4 (fixed) 11 = Reserved

Note: 1. Not allowed when 1/4 rate gear-down mode is enabled.

### Burst Length, Type, and Order

Accesses within a given burst may be programmed to sequential or interleaved order. The ordering of accesses within a burst is determined by the burst length, burst type, and the starting column address as shown in the following table. Burst length options

include fixed BC4, fixed BL8, and on-the-fly (OTF), which allows BC4 or BL8 to be selected coincidentally with the registration of a READ or WRITE command via A12/BC\_n.

**Table 7: Burst Type and Burst Order**

Note 1 applies to the entire table

Burst Length	READ/ WRITE	Starting Column Address (A[2, 1, 0])	Burst Type = Sequential (Decimal)	Burst Type = Interleaved (Decimal)	Notes
BC4	READ	0 0 0	0, 1, 2, 3, T, T, T, T	0, 1, 2, 3, T, T, T, T	2, 3
		0 0 1	1, 2, 3, 0, T, T, T, T	1, 0, 3, 2, T, T, T, T	2, 3
		0 1 0	2, 3, 0, 1, T, T, T, T	2, 3, 0, 1, T, T, T, T	2, 3
		0 1 1	3, 0, 1, 2, T, T, T, T	3, 2, 1, 0, T, T, T, T	2, 3
		1 0 0	4, 5, 6, 7, T, T, T, T	4, 5, 6, 7, T, T, T, T	2, 3
		1 0 1	5, 6, 7, 4, T, T, T, T	5, 4, 7, 6, T, T, T, T	2, 3
		1 1 0	6, 7, 4, 5, T, T, T, T	6, 7, 4, 5, T, T, T, T	2, 3
		1 1 1	7, 4, 5, 6, T, T, T, T	7, 6, 5, 4, T, T, T, T	2, 3
	WRITE	0, V, V	0, 1, 2, 3, X, X, X, X	0, 1, 2, 3, X, X, X, X	2, 3
		1, V, V	4, 5, 6, 7, X, X, X, X	4, 5, 6, 7, X, X, X, X	2, 3
BL8	READ	0 0 0	0, 1, 2, 3, 4, 5, 6, 7	0, 1, 2, 3, 4, 5, 6, 7	
		0 0 1	1, 2, 3, 0, 5, 6, 7, 4	1, 0, 3, 2, 5, 4, 7, 6	
		0 1 0	2, 3, 0, 1, 6, 7, 4, 5	2, 3, 0, 1, 6, 7, 4, 5	
		0 1 1	3, 0, 1, 2, 7, 4, 5, 6	3, 2, 1, 0, 7, 6, 5, 4	
		1 0 0	4, 5, 6, 7, 0, 1, 2, 3	4, 5, 6, 7, 0, 1, 2, 3	
		1 0 1	5, 6, 7, 4, 1, 2, 3, 0	5, 4, 7, 6, 1, 0, 3, 2	
		1 1 0	6, 7, 4, 5, 2, 3, 0, 1	6, 7, 4, 5, 2, 3, 0, 1	
		1 1 1	7, 4, 5, 6, 3, 0, 1, 2	7, 6, 5, 4, 3, 2, 1, 0	
	WRITE	V, V, V	0, 1, 2, 3, 4, 5, 6, 7	0, 1, 2, 3, 4, 5, 6, 7	3

- Notes:
- 0...7 bit number is the value of CA[2:0] that causes this bit to be the first read during a burst.
  - When setting burst length to BC4 (fixed) in MR0, the internal WRITE operation starts two clock cycles earlier than for the BL8 mode, meaning the starting point for <sup>t</sup>WR and <sup>t</sup>WTR will be pulled in by two clocks. When setting burst length to OTF in MR0, the internal WRITE operation starts at the same time as a BL8 (even if BC4 was selected during column time using A12/BC4\_n) meaning that if the OTF MR0 setting is used, the starting point for <sup>t</sup>WR and <sup>t</sup>WTR will not be pulled in by two clocks as described in the BC4 (fixed) case.
  - T = Output driver for data and strobes are in High-Z.  
V = Valid logic level (0 or 1), but respective buffer input ignores level on input pins.  
X = "Don't Care."

## CAS Latency

The CAS latency (CL) setting is defined in the MR0 Register Definition table. CAS latency is the delay, in clock cycles, between the internal READ command and the availability of the first bit of output data. The device does not support half-clock latencies. The

overall read latency (RL) is defined as additive latency (AL) + CAS latency (CL):  $RL = AL + CL$ .

## Test Mode

The normal operating mode is selected by MR0[7] and all other bits set to the desired values shown in the MR0 Register Definition table. Programming MR0[7] to a value of 1 places the device into a DRAM manufacturer-defined test mode to be used only by the manufacturer, not by the end user. No operations or functionality is specified if MR0[7] = 1.

## Write Recovery(WR)/READ-to-PRECHARGE

The programmed write recovery (WR) value is used for the auto precharge feature along with  $t_{RP}$  to determine  $t_{DAL}$ . WR for auto precharge (MIN) in clock cycles is calculated by dividing  $t_{WR}$  (in ns) by  $t_{CK}$  (in ns) and rounding up to the next integer:  $WR (MIN) \text{ cycles} = \text{roundup} (t_{WR}[ns] / t_{CK}[ns])$ . The WR value must be programmed to be equal to or larger than  $t_{WR} (MIN)$ . When both DM and write CRC are enabled in the mode register, the device calculates CRC before sending the write data into the array;  $t_{WR}$  values will change when enabled. If there is a CRC error, the device blocks the WRITE operation and discards the data.

Internal READ-to-PRECHARGE (RTP) command delay for auto precharge (MIN) in clock cycles is calculated by dividing  $t_{RTP}$  (in ns) by  $t_{CK}$  (in ns) and rounding up to the next integer:  $RTP (MIN) \text{ cycles} = \text{roundup} (t_{RTP}[ns] / t_{CK}[ns])$ . The RTP value in the mode register must be programmed to be equal to or larger than  $t_{RTP} (MIN)$ . The programmed RTP value is used with  $t_{RP}$  to determine the ACT timing to the same bank.

## DLL RESET

The DLL reset bit is self-clearing, meaning that it returns to the value of 0 after the DLL RESET function has been issued. After the DLL is enabled, a subsequent DLL RESET should be applied. Any time the DLL RESET function is used,  $t_{DLLK}$  must be met before functions requiring the DLL can be used, such as READ commands or synchronous ODT operations, for example,).

## Mode Register 1

Mode register 1 (MR1) controls various device operating modes as shown in the following register definition table. Not all settings listed may be available on a die; only settings required for speed bin support are available. MR1 is written by issuing the MRS command while controlling the states of the BG<sub>x</sub>, BA<sub>x</sub>, and A<sub>x</sub> address pins. The mapping of address pins during the MRS command is shown in the following MR1 Register Definition table.

**Table 8: Address Pin Mapping**

Address bus	BG1	BG0	BA1	BA0	A17	RAS_n	CAS_n	WE_n	A13	A12	A11	A10	A9	A8	A7	A6	A5	A4	A3	A2	A1	A0
Mode register	21	20	19	18	17	–	–	–	13	12	11	10	9	8	7	6	5	4	3	2	1	0

Note: 1. RAS<sub>n</sub>, CAS<sub>n</sub>, and WE<sub>n</sub> must be LOW during MODE REGISTER SET command.

**Table 9: MR1 Register Definition**

Mode Register	Description
21	<b>RFU</b> 0 = Must be programmed to 0 1 = Reserved
20:18	<b>MR select</b> 000 = MR0 <b>001 = MR1</b> 010 = MR2 011 = MR3 100 = MR4 101 = MR5 110 = MR6 111 = DNU
17	<b>N/A on 4Gb and 8Gb, RFU</b> 0 = Must be programmed to 0 1 = Reserved
13	<b>RFU</b> 0 = Must be programmed to 0 1 = Reserved
12	<b>Data output disable (Qoff) – Output buffer disable</b> 0 = Enabled (normal operation) 1 = Disabled (both ODI and R <sub>TT</sub> )
11	<b>Termination data strobe (TDQS) – Additional termination pins (x8 configuration only)</b> 0 = TDQS disabled 1 = TDQS enabled

**Table 9: MR1 Register Definition (Continued)**

Mode Register	Description
10, 9, 8	<b>Nominal ODT (<math>R_{TT(NOM)}</math>) – Data bus termination setting</b> 000 = $R_{TT(NOM)}$ disabled 001 = RZQ/4 (60 ohm) 010 = RZQ/2 (120 ohm) 011 = RZQ/6 (40 ohm) 100 = RZQ/1 (240 ohm) 101 = RZQ/5 (48 ohm) 110 = RZQ/3 (80 ohm) 111 = RZQ/7 (34 ohm)
7	<b>Write leveling (WL) – Write leveling mode</b> 0 = Disabled (normal operation) 1 = Enabled (enter WL mode)
6, 5	<b>RFU</b> 0 = Must be programmed to 0 1 = Reserved
4, 3	<b>Additive latency (AL) – Command additive latency setting</b> 00 = 0 (AL disabled) 01 = CL - 1 <sup>1</sup> 10 = CL - 2 11 = Reserved
2, 1	<b>Output driver impedance (ODI) – Output driver impedance setting</b> 00 = RZQ/7 (34 ohm) 01 = RZQ/5 (48 ohm) 10 = Reserved (Although not JEDEC-defined and not tested, this setting will provide RZQ/6 or 40 ohm) 11 = Reserved
0	<b>DLL enable – DLL enable feature</b> 0 = DLL disabled 1 = DLL enabled (normal operation)

Note: 1. Not allowed when 1/4 rate gear-down mode is enabled.

## DLL Enable/DLL Disable

The DLL must be enabled for normal operation and is required during power-up initialization and upon returning to normal operation after having the DLL disabled. During normal operation (DLL enabled with MR1[0]) the DLL is automatically disabled when entering the SELF REFRESH operation and is automatically re-enabled upon exit of the SELF REFRESH operation. Any time the DLL is enabled and subsequently reset, <sup>t</sup>DLLK clock cycles must occur before a READ or SYNCHRONOUS ODT command can be issued to allow time for the internal clock to be synchronized with the external clock. Failing to wait for synchronization to occur may result in a violation of the <sup>t</sup>DQSCK, <sup>t</sup>AON, or <sup>t</sup>AOF parameters.

During <sup>t</sup>DLLK, CKE must continuously be registered HIGH. The device does not require DLL for any WRITE operation, except when  $R_{TT(WR)}$  is enabled and the DLL is required for proper ODT operation.

The direct ODT feature is not supported during DLL off mode. The ODT resistors must be disabled by continuously registering the ODT pin LOW and/or by programming the  $R_{TT(NOM)}$  bits  $MR1[9,6,2] = 000$  via an MRS command during DLL off mode.

The dynamic ODT feature is not supported in DLL off mode; to disable dynamic ODT externally, use the MRS command to set  $R_{TT(WR)}$ ,  $MR2[10:9] = 00$ .

## Output Driver Impedance Control

The output driver impedance of the device is selected by  $MR1[2,1]$ , as shown in the MR1 Register Definition table.

## ODT $R_{TT(NOM)}$ Values

The device is capable of providing three different termination values:  $R_{TT(Static)}$ ,  $R_{TT(NOM)}$ , and  $R_{TT(WR)}$ . The nominal termination value,  $R_{TT(NOM)}$ , is programmed in MR1. A separate value,  $R_{TT(WR)}$ , may be programmed in MR2 to enable a unique  $R_{TT}$  value when ODT is enabled during WRITE operations. The  $R_{TT(WR)}$  value can be applied during WRITE commands even when  $R_{TT(NOM)}$  is disabled. A third  $R_{TT}$  value,  $R_{TT(Static)}$ , is programmed in MR5.  $R_{TT(Static)}$  provides a termination value when the ODT signal is LOW.

## Additive Latency

The ADDITIVE LATENCY (AL) operation is supported to make command and data buses efficient for sustainable bandwidths in the device. In this operation, the device allows a READ or WRITE command (either with or without auto precharge) to be issued immediately after the ACTIVATE command. The command is held for the time of AL before it is issued inside the device. READ latency (RL) is controlled by the sum of the AL and CAS latency (CL) register settings. WRITE latency (WL) is controlled by the sum of the AL and CAS WRITE latency (CWL) register settings.

**Table 10: Additive Latency (AL) Settings**

A4	A3	AL
0	0	0 (AL disabled)
0	1	CL - 1
1	0	CL - 2
1	1	Reserved

Note: 1. AL has a value of CL - 1 or CL - 2 based on the CL values programmed in the MR0 register.

## Write Leveling

For better signal integrity, the device uses fly-by topology for the commands, addresses, control signals, and clocks. Fly-by topology benefits from a reduced number of stubs and their lengths, but it causes flight-time skew between clock and strobe at every DRAM on the DIMM. This makes it difficult for the controller to maintain 'DQSS, 'DSS, and 'DSH specifications. Therefore, the device supports a write leveling feature that allows the controller to compensate for skew.

## Output Disable

The device outputs may be enabled/disabled by MR1[12] as shown in the MR1 Register Definition table. When MR1[12] is enabled (MR1[12] = 1) all output pins (such as DQ and DQS) are disconnected from the device, which removes any loading of the output drivers. For example, this feature may be useful when measuring module power. For normal operation, set MR1[12] to 0.

## Termination Data Strobe

Termination data strobe (TDQS) is a feature of the x8 device and provides additional termination resistance outputs that may be useful in some system configurations. Because this function is available only in a x8 configuration, it must be disabled for x4 and x16 configurations.

While TDQS is not supported in x4 or x16 configurations, the same termination resistance function that is applied to the TDQS pins is applied to the DQS pins when enabled via the mode register.

The TDQS, DBI, and DATA MASK (DM) functions share the same pin. When the TDQS function is enabled via the mode register, the DM and DBI functions are not supported. When the TDQS function is disabled, the DM and DBI functions can be enabled separately.

**Table 11: TDQS Function Matrix**

TDQS	Data Mask (DM)	WRITE DBI	READ DBI
Disabled	<b>Enabled</b>	Disabled	<b>Enabled</b> or disabled
	Disabled	<b>Enabled</b>	<b>Enabled</b> or disabled
	Disabled	Disabled	<b>Enabled</b> or disabled
<b>Enabled</b>	Disabled	Disabled	Disabled

## Mode Register 2

Mode register 2 (MR2) controls various device operating modes as shown in the following register definition table. Not all settings listed may be available on a die; only settings required for speed bin support are available. MR2 is written by issuing the MRS command while controlling the states of the BG<sub>x</sub>, BA<sub>x</sub>, and A<sub>x</sub> address pins. The mapping of address pins during the MRS command is shown in the following MR2 Register Definition table.

**Table 12: Address Pin Mapping**

Address bus	BG1	BG0	BA1	BA0	A17	RAS_n	CAS_n	WE_n	A13	A12	A11	A10	A9	A8	A7	A6	A5	A4	A3	A2	A1	A0
Mode register	21	20	19	18	17	–	–	–	13	12	11	10	9	8	7	6	5	4	3	2	1	0

Note: 1. RAS<sub>n</sub>, CAS<sub>n</sub>, and WE<sub>n</sub> must be LOW during MODE REGISTER SET command.

**Table 13: MR2 Register Definition**

Mode Register	Description
21	<b>RFU</b> 0 = Must be programmed to 0 1 = Reserved
20:18	<b>MR select</b> 000 = MR0 001 = MR1 <b>010 = MR2</b> 011 = MR3 100 = MR4 101 = MR5 110 = MR6 111 = DNU
17	<b>N/A on 4Gb and 8Gb, RFU</b> 0 = Must be programmed to 0 1 = Reserved
13	<b>TRR mode</b> 0 = Disabled 1 = Enabled
12	<b>WRITE data bus CRC</b> 0 = Disabled 1 = Enabled

Table 13: MR2 Register Definition (Continued)

Mode Register	Description
11:9	<p><b>Dynamic ODT (<math>R_{TT(WR)}</math>) – Data bus termination setting during WRITES</b></p> <p>000 = <math>R_{TT(WR)}</math> disabled (WRITE does not affect <math>R_{TT}</math> value)            001 = RZQ/2 (120 ohm)            010 = RZQ/1 (240 ohm)            011 = High-Z            100 = RZQ/3 (80 ohm)            101 = Reserved            110 = Reserved            111 = Reserved</p>
7:6	<p><b>Low-power auto self refresh (LPASR) – Mode summary</b></p> <p>00 = Manual mode - Normal operating temperature range (<math>T_C</math>: 0°C–85°C)            01 = Manual mode - Reduced operating temperature range (<math>T_C</math>: 0°C–45°C)            10 = Manual mode - Extended operating temperature range (<math>T_C</math>: 0°C–95°C)            11 = ASR mode - Automatically switching among all modes</p>
5:3	<p><b>CAS WRITE latency (CWL) – Delay in clock cycles from the internal WRITE command to first data-in 1<sup>t</sup>CK WRITE preamble</b></p> <p>000 = 9 (DDR4-1600)<sup>1</sup>            001 = 10 (DDR4-1866)            010 = 11 (DDR4-2133/1600)<sup>1</sup>            011 = 12 (DDR4-2400/1866)            100 = 14 (DDR4-2666/2133)            101 = 16 (DDR4-2933,3200/2400)            110 = 18 (DDR4-2666)            111 = 20 (DDR4-2933, 3200)</p>
	<p><b>CAS WRITE latency (CWL) – Delay in clock cycles from the internal WRITE command to first data-in 2<sup>t</sup>CK WRITE preamble</b></p> <p>000 = N/A            001 = N/A            010 = N/A            011 = N/A            100 = 14 (DDR4-2400)            101 = 16 (DDR4-2666/2400)            110 = 18 (DDR4-2933, 3200/2666)            111 = 20 (DDR4-2933, 3200)</p>
8, 2	<p><b>TRR mode - BGn control</b></p> <p>00 = BG0            01 = BG1            10 = BG2            11 = BG3</p>
1:0	<p><b>TRR mode - BAn control</b></p> <p>00 = BA0            01 = BA1            10 = BA2            11 = BA3</p>

Note: 1. Not allowed when 1/4 rate gear-down mode is enabled.

## CAS WRITE Latency

CAS WRITE latency (CWL) is defined by MR2[5:3] as shown in the MR2 Register Definition table. CWL is the delay, in clock cycles, between the internal WRITE command and the availability of the first bit of input data. The device does not support any half-clock latencies. The overall WRITE latency (WL) is defined as additive latency (AL) + parity latency (PL) + CAS WRITE latency (CWL):  $WL = AL + PL + CWL$ .

## Low-Power Auto Self Refresh

Low-power auto self refresh (LPASR) is supported in the device. Applications requiring SELF REFRESH operation over different temperature ranges can use this feature to optimize the  $I_{DD6}$  current for a given temperature range as specified in the MR2 Register Definition table.

## Dynamic ODT

In certain applications and to further enhance signal integrity on the data bus, it is desirable to change the termination strength of the device without issuing an MRS command. This may be done by configuring the dynamic ODT ( $R_{TT(WR)}$ ) settings in MR2[11:9]. In write leveling mode, only  $R_{TT(NOM)}$  is available.

## Write Cyclic Redundancy Check Data Bus

The write cyclic redundancy check (CRC) data bus feature during writes has been added to the device. When enabled via the mode register, the data transfer size goes from the normal 8-bit (BL8) frame to a larger 10-bit UI frame, and the extra two UIs are used for the CRC information.

## Target Row Refresh Mode

For the device, rows can be accessed a limited number of times within a certain time period before adjacent rows require refresh. The maximum activate count (MAC) is the maximum number of activates that a single row can sustain within a time interval of equal to or less than the maximum activate window ( ${}^tMAW$ ) before the adjacent rows need to be refreshed regardless of how the activates are distributed over  ${}^tMAW$ . The row receiving the excessive activates is the target row ( $TR_n$ ); the two adjacent rows to be refreshed are the victim rows.

When the MAC limit is reached on  $TR_n$ , either the device must receive (roundup of  ${}^tMAW / {}^tREFI$ ) REFRESH commands (REF) before another row activate is issued, or it needs to be placed into targeted row refresh (TRR) mode. The TRR mode will refresh the rows adjacent to the  $TR_n$  that encountered the MAC limit. There could be one or two target rows in a bank associated to one victim row. The cumulative value of the activates from two target rows on a victim row should not exceed the MAC value as well. When the temperature controlled refresh (TCR) mode is enabled,  ${}^tMAW$  should be adjusted depending on the TCR range as shown in the following table.

Using TRR mode is not required, and in some cases has been rendered inoperable, as the device automatically performs TRR Mode in the background.

## Mode Register 3

Mode register 3 (MR3) controls various device operating modes as shown in the following register definition table. Not all settings listed may be available on a die; only settings required for speed bin support are available. MR3 is written by issuing the MRS command while controlling the states of the BG<sub>x</sub>, BA<sub>x</sub>, and A<sub>x</sub> address pins. The mapping of address pins during the MRS command is shown in the following MR3 Register Definition table.

**Table 14: Address Pin Mapping**

Address bus	BG1	BG0	BA1	BA0	A17	RAS_n	CAS_n	WE_n	A13	A12	A11	A10	A9	A8	A7	A6	A5	A4	A3	A2	A1	A0
Mode register	21	20	19	18	17	–	–	–	13	12	11	10	9	8	7	6	5	4	3	2	1	0

Note: 1. RAS<sub>n</sub>, CAS<sub>n</sub>, and WE<sub>n</sub> must be LOW during MODE REGISTER SET command.

**Table 15: MR3 Register Definition**

Mode Register	Description
21	<b>RFU</b> 0 = Must be programmed to 0 1 = Reserved
20:18	<b>MR select</b> 000 = MR0 001 = MR1 010 = MR2 <b>011 = MR3</b> 100 = MR4 101 = MR5 110 = MR6 111 = DNU
17	<b>N/A on 4Gb and 8Gb, RFU</b> 0 = Must be programmed to 0 1 = Reserved
13	<b>RFU</b> 0 = Must be programmed to 0 1 = Reserved
12:11	<b>Multipurpose register (MPR) – Read format</b> 00 = Serial 01 = Parallel 10 = Staggered 11 = Reserved
10:9	<b>WRITE CMD latency when CRC/DM enabled</b> 00 = 4CK (DDR4-1600) 01 = 5CK (DDR4-1866/2133/2400) 10 = 6CK (DDR4-2666/2933/3200) 11 = Reserved

**Table 15: MR3 Register Definition (Continued)**

Mode Register	Description
8:6	<b>Fine granularity refresh mode</b> 000 = Normal mode (fixed 1x) 001 = Fixed 2x 010 = Fixed 4x 011 = Reserved 100 = Reserved 101 = On-the-fly 1x/2x 110 = On-the-fly 1x/4x 111 = Reserved
5	<b>Temperature sensor status</b> 0 = Disabled 1 = Enabled
4	<b>Per-DRAM addressability</b> 0 = Normal operation (disabled) 1 = Enable
3	<b>Gear-down mode – Ratio of internal clock to external data rate</b> 0 = [1:1]; (1/2 rate data) 1 = [2:1]; (1/4 rate data)
2	<b>Multipurpose register (MPR) access</b> 0 = Normal operation 1 = Data flow from MPR
1:0	<b>MPR page select</b> 00 = Page 0 01 = Page 1 10 = Page 2 11 = Page 3 (restricted for DRAM manufacturer use only)

## Multipurpose Register

The multipurpose register (MPR) is used for several features:

- Readout of the contents of the MR $n$  registers
- WRITE and READ system patterns used for data bus calibration
- Readout of the error frame when the command address parity feature is enabled

To enable MPR, issue an MRS command to MR3[2] = 1. MR3[12:11] define the format of read data from the MPR. Prior to issuing the MRS command, all banks must be in the idle state (all banks precharged and t<sub>RP</sub> met). After MPR is enabled, any subsequent RD or RDA commands will be redirected to a specific mode register.

The mode register location is specified with the READ command using address bits. The MR is split into upper and lower halves to align with a burst length limitation of 8. Power-down mode, SELF REFRESH, and any other nonRD/RDA or nonWR/WRA commands are not allowed during MPR mode. The RESET function is supported during MPR mode, which requires device re-initialization.

## **WRITE Command Latency When CRC/DM is Enabled**

The WRITE command latency (WCL) must be set when both write CRC and DM are enabled for write CRC persistent mode. This provides the extra time required when completing a WRITE burst when write CRC and DM are enabled.

## **Fine Granularity Refresh Mode**

This mode had been added to DDR4 to help combat the performance penalty due to refresh lockout at high densities. Shortening  $t_{RFC}$  and increasing cycle time allows more accesses to the chip and can produce higher bandwidth.

## **Temperature Sensor Status**

This mode directs the DRAM to update the temperature sensor status at MPR Page 2, MPR0 [4,3]. The temperature sensor setting should be updated within 32ms; when an MPR read of the temperature sensor status bits occurs, the temperature sensor status should be no older than 32ms.

## **Per-DRAM Addressability**

This mode allows commands to be masked on a per device basis providing any device in a rank (devices sharing the same command and address signals) to be programmed individually. As an example, this feature can be used to program different ODT or  $V_{REF}$  values on DRAM devices within a given rank.

## **Gear-Down Mode**

The device defaults in 1/2 rate (1N) clock mode and uses a low frequency MRS command followed by a sync pulse to align the proper clock edge for operating the control lines CS<sub>n</sub>, CKE, and ODT when in 1/4 rate (2N) mode. For operation in 1/2 rate mode, no MRS command or sync pulse is required.

## Mode Register 4

Mode register 4 (MR4) controls various device operating modes as shown in the following register definition table. Not all settings listed may be available on a die; only settings required for speed bin support are available. MR4 is written by issuing the MRS command while controlling the states of the BG<sub>x</sub>, BA<sub>x</sub>, and A<sub>x</sub> address pins. The mapping of address pins during the MRS command is shown in the following MR4 Register Definition table.

**Table 16: Address Pin Mapping**

Address bus	BG1	BG0	BA1	BA0	A17	RAS_n	CAS_n	WE_n	A13	A12	A11	A10	A9	A8	A7	A6	A5	A4	A3	A2	A1	A0
Mode register	21	20	19	18	17	–	–	–	13	12	11	10	9	8	7	6	5	4	3	2	1	0

Note: 1. RAS<sub>n</sub>, CAS<sub>n</sub>, and WE<sub>n</sub> must be LOW during MODE REGISTER SET (MRS) command.

**Table 17: MR4 Register Definition**

Mode Register	Description
21	<b>RFU</b> 0 = Must be programmed to 0 1 = Reserved
20:18	<b>MR select</b> 000 = MR0 001 = MR1 010 = MR2 011 = MR3 <b>100 = MR4</b> 101 = MR5 110 = MR6 111 = DNU
17	<b>N/A on 4Gb and 8Gb, RFU</b> 0 = Must be programmed to 0 1 = Reserved
13	<b>Post Package Repair (PPR mode)</b> 0 = Disabled 1 = Enabled
12	<b>WRITE preamble setting</b> 0 = 1 <sup>t</sup> CK toggle <sup>1</sup> 1 = 2 <sup>t</sup> CK toggle
11	<b>READ preamble setting</b> 0 = 1 <sup>t</sup> CK toggle <sup>1</sup> 1 = 2 <sup>t</sup> CK toggle (When operating in 2 <sup>t</sup> CK WRITE preamble mode, CWL must be programmed to a value at least 1 clock greater than the lowest CWL setting supported in the applicable <sup>t</sup> CK range.)
10	<b>READ preamble training</b> 0 = Disabled 1 = Enabled

**Table 17: MR4 Register Definition (Continued)**

Mode Register	Description
9	<b>Self refresh abort mode</b> 0 = Disabled 1 = Enabled
8:6	<b>CMD (CAL) address latency</b> 000 = 0 clocks (disabled) 001 = 3 clocks <sup>1</sup> 010 = 4 clocks 011 = 5 clocks <sup>1</sup> 100 = 6 clocks 101 = 8 clocks 110 = Reserved 111 = Reserved
5	<b>soft Post Package Repair (sPPR mode)</b> 0 = Disabled 1 = Enabled
4	<b>Internal V<sub>REF</sub> monitor</b> 0 = Disabled 1 = Enabled
3	<b>Temperature controlled refresh mode</b> 0 = Disabled 1 = Enabled
2	<b>Temperature controlled refresh range</b> 0 = Normal temperature mode 1 = Extended temperature mode
1	<b>Maximum power savings mode</b> 0 = Normal operation 1 = Enabled
0	<b>RFU</b> 0 = Must be programmed to 0 1 = Reserved

Note: 1. Not allowed when 1/4 rate gear-down mode is enabled.

## Post Package Repair Mode

The post package repair (PPR) mode feature is JEDEC optional for 4Gb DDR4 memories. Performing an MPR read to page 2 MPR0 [7] indicates whether PPR mode is available (A7 = 1) or not available (A7 = 0). PPR mode provides a simple and easy repair method of the device after placed in the system. One row per bank group can be repaired. The repair process is irrevocable so great care should be exercised when using.

## Soft Post Package Repair Mode

The soft post package repair (sPPR) mode feature is JEDEC optional for 4Gb and 8Gb DDR4 memories. Performing an MPR read to page 2 MPR0 [6] indicates whether sPPR mode is available (A6 = 1) or not available (A6 = 0). sPPR mode provides a simple and

easy repair method of the device after placed in the system. One row per bank group can be repaired. The repair process is revocable by either doing a reset or power-down.

## WRITE Preamble

Programmable WRITE preamble,  $t_{\text{WPRE}}$ , can be set to  $1^t\text{CK}$  or  $2^t\text{CK}$  via the MR4 register. The  $1^t\text{CK}$  setting is similar to DDR3. However, when operating in  $2^t\text{CK}$  WRITE preamble mode, CWL must be programmed to a value at least 1 clock greater than the lowest CWL setting supported in the applicable  $t^t\text{CK}$  range.

## READ Preamble

Programmable READ preamble  $t_{\text{RPRE}}$  can be set to  $1^t\text{CK}$  or  $2^t\text{CK}$  via the MR4 register. Both the  $1^t\text{CK}$  and  $2^t\text{CK}$  DDR4 preamble settings are different from that defined for the DDR3 SDRAM. Both DDR4 READ preamble settings may require the memory controller to train (or read level) its data strobe receivers using the READ preamble training.

When operating in  $2^t\text{CK}$  WRITE preamble mode, CWL must be programmed to a value at least 1 clock greater than the lowest CWL setting supported in the applicable  $t^t\text{CK}$  range. Some even settings will require addition of 2 clocks. If the alternate longer CWL was used, the additional clocks will not be required.

## READ Preamble Training

Programmable READ preamble training can be set to  $1^t\text{CK}$  or  $2^t\text{CK}$ . This mode can be used by the memory controller to train or READ level its data strobe receivers.

## Temperature-Controlled Refresh

When temperature-controlled refresh mode is enabled, the device may adjust the internal refresh period to be longer than  $t_{\text{REFI}}$  of the normal temperature range by skipping external REFRESH commands with the proper gear ratio. For example, the DRAM temperature sensor detected less than  $45^{\circ}\text{C}$ . Normal temperature mode covers the range of  $0^{\circ}\text{C}$  to  $85^{\circ}\text{C}$ , while the extended temperature range covers  $0^{\circ}\text{C}$  to  $95^{\circ}\text{C}$ .

## Command Address Latency

COMMAND ADDRESS LATENCY (CAL) is a power savings feature and can be enabled or disabled via the MRS setting. CAL is defined as the delay in clock cycles ( $t_{\text{CAL}}$ ) between a  $\text{CS}_n$  registered LOW and its corresponding registered command and address. The value of CAL (in clocks) must be programmed into the mode register and is based on the roundup (in clocks) of  $\lceil t^t\text{CK}(\text{ns})/t^t\text{CAL}(\text{ns}) \rceil$ .

## Internal $V_{\text{REF}}$ Monitor

The device generates its own internal  $V_{\text{REFDQ}}$ . This mode may be enabled during  $V_{\text{REFDQ}}$  training, and when enabled,  $V_{\text{REFtime-short}}$  and  $V_{\text{REFtime-long}}$  need to be increased by 10ns if DQ0, DQ1, DQ2, or DQ3 have 0pF loading. An additional 15ns per pF of loading is also needed.

## Maximum Power Savings Mode

This mode provides the lowest power mode where data retention is not required. When the device is in the maximum power saving mode, it does not need to guarantee data



## 4Gb: x4, x8, x16 DDR4 SDRAM Mode Register 4

---

retention or respond to any external command (except the MAXIMUM POWER SAVING MODE EXIT command and during the assertion of RESET\_n signal LOW).

## Mode Register 5

Mode register 5 (MR5) controls various device operating modes as shown in the following register definition table. Not all settings listed may be available on a die; only settings required for speed bin support are available. MR5 is written by issuing the MRS command while controlling the states of the BG<sub>x</sub>, BA<sub>x</sub>, and A<sub>x</sub> address pins. The mapping of address pins during the MRS command is shown in the following MR5 Register Definition table.

**Table 18: Address Pin Mapping**

Address bus	BG1	BG0	BA1	BA0	A17	RAS_n	CAS_n	WE_n	A13	A12	A11	A10	A9	A8	A7	A6	A5	A4	A3	A2	A1	A0
Mode register	21	20	19	18	17	–	–	–	13	12	11	10	9	8	7	6	5	4	3	2	1	0

Note: 1. RAS<sub>n</sub>, CAS<sub>n</sub>, and WE<sub>n</sub> must be LOW during MODE REGISTER SET command.

**Table 19: MR5 Register Definition**

Mode Register	Description
21	<b>RFU</b> 0 = Must be programmed to 0 1 = Reserved
20:18	<b>MR select</b> 000 = MR0 001 = MR1 010 = MR2 011 = MR3 100 = MR4 <b>101 = MR5</b> 110 = MR6 111 = DNU
17	<b>N/A on 4Gb and 8Gb, RFU</b> 0 = Must be programmed to 0 1 = Reserved
13	<b>RFU</b> 0 = Must be programmed to 0 1 = Reserved
12	<b>Data bus inversion (DBI) – READ DBI enable</b> 0 = Disabled 1 = Enabled
11	<b>Data bus inversion (DBI) – WRITE DBI enable</b> 0 = Disabled 1 = Enabled
10	<b>Data mask (DM)</b> 0 = Disabled 1 = Enabled

**Table 19: MR5 Register Definition (Continued)**

Mode Register	Description
9	<b>CA parity persistent error mode</b> 0 = Disabled 1 = Enabled
8:6	<b>Parked ODT value (<math>R_{TT(Park)}</math>)</b> 000 = $R_{TT(Park)}$ disabled 001 = RZQ/4 (60 ohm) 010 = RZQ/2 (120 ohm) 011 = RZQ/6 (40 ohm) 100 = RZQ/1 (240 ohm) 101 = RZQ/5 (48 ohm) 110 = RZQ/3 (80 ohm) 111 = RZQ/7 (34 ohm)
5	<b>ODT input buffer for power-down</b> 0 = Buffer enabled 1 = Buffer disabled
4	<b>CA parity error status</b> 0 = Clear 1 = Error
3	<b>CRC error status</b> 0 = Clear 1 = Error
2:0	<b>CA parity latency mode</b> 000 = Disable 001 = 4 clocks (DDR4-1600/1866/2133) 010 = 5 clocks (DDR4-2400) <sup>1</sup> 011 = 6 clocks (DDR4-2666) 100 = 8 clocks (DDR4-2933/3200) 101 = Reserved 110 = Reserved 111 = Reserved

Note: 1. Not allowed when 1/4 rate gear-down mode is enabled.

## Data Bus Inversion

The DATA BUS INVERSION (DBI) function has been added to the device and is supported only for x8 and x16 configurations (x4 is not supported). The DBI function shares a common pin with the DM and TDQS functions. The DBI function applies to both READ and WRITE operations; Write DBI cannot be enabled at the same time the DM function is enabled. Refer to the TDQS Function Matrix table for valid configurations for all three functions (TDQS/DM/DBI). DBI is not allowed during MPR READ operation; during an MPR read, the DRAM ignores the read DBI enable setting in MR5 bit A12. DBI is not allowed during MPR READ operations.

## Data Mask

The DATA MASK (DM) function, also described as a partial write, has been added to the device and is supported only for x8 and x16 configurations (x4 is not supported). The DM function shares a common pin with the DBI and TDQS functions. The DM function applies only to WRITE operations and cannot be enabled at the same time the write DBI function is enabled. Refer to the TDQS Function Matrix table for valid configurations for all three functions (TDQS/DM/DBI).

## CA Parity Persistent Error Mode

Normal CA parity mode (CA parity persistent mode disabled) no longer performs CA parity checking while the parity error status bit remains set at 1. However, with CA parity persistent mode enabled, CA parity checking continues to be performed when the parity error status bit is set to a 1.

## ODT Input Buffer for Power-Down

This feature determines whether the ODT input buffer is on or off during power-down. If the input buffer is configured to be on (enabled during power-down), the ODT input signal must be at a valid logic level. If the input buffer is configured to be off (disabled during power-down), the ODT input signal may be floating and the device does not provide  $R_{TT(NOM)}$  termination. However, the device may provide  $R_{TT(Park)}$  termination depending on the MR settings. This is primarily for additional power savings.

## CA Parity Error Status

The device will set the error status bit to 1 upon detecting a parity error. The parity error status bit remains set at 1 until the device controller clears it explicitly using an MRS command.

## CRC Error Status

The device will set the error status bit to 1 upon detecting a CRC error. The CRC error status bit remains set at 1 until the device controller clears it explicitly using an MRS command.

## CA Parity Latency Mode

CA parity is enabled when a latency value, dependent on  $t_{CK}$ , is programmed; this accounts for parity calculation delay internal to the device. The normal state of CA parity is to be disabled. If CA parity is enabled, the device must ensure there are no parity errors before executing the command. CA parity signal (PAR) covers ACT<sub>n</sub>, RAS<sub>n</sub>/A16, CAS<sub>n</sub>/A15, WE<sub>n</sub>/A14, and the address bus including bank address and bank group bits. The control signals CKE, ODT, and CS<sub>n</sub> are not included in the parity calculation.

## Mode Register 6

Mode register 6 (MR6) controls various device operating modes as shown in the following register definition table. Not all settings listed may be available on a die; only settings required for speed bin support are available. MR6 is written by issuing the MRS command while controlling the states of the BG<sub>x</sub>, BA<sub>x</sub>, and A<sub>x</sub> address pins. The mapping of address pins during the MRS command is shown in the following MR6 Register Definition table.

**Table 20: Address Pin Mapping**

Address bus	BG1	BG0	BA1	BA0	A17	RAS_n	CAS_n	WE_n	A13	A12	A11	A10	A9	A8	A7	A6	A5	A4	A3	A2	A1	A0
Mode register	21	20	19	18	17	–	–	–	13	12	11	10	9	8	7	6	5	4	3	2	1	0

Note: 1. RAS<sub>n</sub>, CAS<sub>n</sub>, and WE<sub>n</sub> must be LOW during MODE REGISTER SET command.

**Table 21: MR6 Register Definition**

Mode Register	Description
21	<b>RFU</b> 0 = Must be programmed to 0 1 = Reserved
20:18	<b>MR select</b> 000 = MR0 001 = MR1 010 = MR2 011 = MR3 100 = MR4 101 = MR5 <b>110 = MR6</b> 111 = DNU
17	<b>NA on 4Gb and 8Gb, RFU</b> 0 = Must be programmed to 0 1 = Reserved
13	<b>RFU</b> 0 = Must be programmed to 0 1 = Reserved
12:10	<b><sup>t</sup>CCD_L</b> 000 = 4 clocks (≤1333 Mb/s) 001 = 5 clocks (>1333 Mb/s and ≤1866 Mb/s) 010 = 6 clocks (>1866 Mb/s and ≤2400 Mb/s) 011 = 7 clocks (>2400 Mb/s and ≤2666 Mb/s) 100 = 8 clocks (>2666 Mb/s and ≤3200 Mb/s) 101 = Reserved 110 = Reserved 111 = Reserved

**Table 21: MR6 Register Definition (Continued)**

Mode Register	Description
9, 8	<b>RFU</b> 0 = Must be programmed to 0 1 = Reserved
7	<b>V<sub>REF</sub> Calibration Enable</b> 0 = Disable 1 = Enable
6	<b>V<sub>REF</sub> Calibration Range</b> 0 = Range 1 1 = Range 2
5:0	<b>V<sub>REF</sub> Calibration Value</b> See the V <sub>REFDQ</sub> Range and Levels table in the V <sub>REFDQ</sub> Calibration section

### <sup>t</sup>CCD\_L Programming

The device controller must program the correct <sup>t</sup>CCD\_L value. <sup>t</sup>CCD\_L will be programmed according to the value defined per operating frequency in the AC parameter table. Although JEDEC specifies the larger of 5nCK or Xns, Micron's DRAM supports the larger of 4nCK or Xns.

### V<sub>REFDQ</sub> Calibration Enable

V<sub>REFDQ</sub> calibration is where the device internally generates its own V<sub>REFDQ</sub> to be used by the DQ input receivers. The V<sub>REFDQ</sub> value will be output on any DQ of DQ[3:0] for evaluation only. The device controller is responsible for setting and calibrating the internal V<sub>REFDQ</sub> level using an MRS protocol (adjust up, adjust down, and so on). It is assumed that the controller will use a series of writes and reads in conduction with V<sub>REFDQ</sub> adjustments to optimize and verify the data eye. Enabling V<sub>REFDQ</sub> calibration must be used whenever values are being written to the MR6[6:0] register.

### V<sub>REFDQ</sub> Calibration Range

The device defines two V<sub>REFDQ</sub> calibration ranges: Range 1 and Range 2. Range 1 supports V<sub>REFDQ</sub> between 60% and 92% of V<sub>DDQ</sub> while Range 2 supports V<sub>REFDQ</sub> between 45% and 77% of V<sub>DDQ</sub>, as seen in V<sub>REFDQ</sub> Specification table. Although not a restriction, Range 1 was targeted for module-based designs and Range 2 was added to target point-to-point designs.

### V<sub>REFDQ</sub> Calibration Value

Fifty settings provide approximately 0.65% of granularity steps sizes for both Range 1 and Range 2 of V<sub>REFDQ</sub>, as seen in V<sub>REFDQ</sub> Range and Levels table in the V<sub>REFDQ</sub> Calibration section.

# Truth Tables

**Table 22: Truth Table – Command**

Notes 1–5 apply to the entire table; Note 6 applies to all READ/WRITE commands

Function	Symbol	Prev. CKE	Pres. CKE	CS <sub>n</sub>	ACT <sub>n</sub>	RAS <sub>n/A16</sub>	CAS <sub>n/A15</sub>	WE <sub>n/A14</sub>	BG[1:0]	BA [1:0]	C[2:0]	A12/BC <sub>n</sub>	A[13,11]
MODE REGISTER SET	MRS	H	H	L	H	L	L	L	BG	BA	V	V	OP cod
REFRESH	REF	H	H	L	H	L	L	H	V	V	V	V	V
Self refresh entry	SRE	H	L	L	H	L	L	H	V	V	V	V	V
Self refresh exit	SRX	L	H	H	X	X	X	X	X	X	X	X	X
Single-bank PRECHARGE	PRE	H	H	L	H	L	H	L	BG	BA	V	V	V
PRECHARGE all banks	PREA	H	H	L	H	L	H	L	V	V	V	V	V
Reserved for future use	RFU	H	H	L	H	L	H	H	V	V	V	V	V
Bank ACTIVATE	ACT	H	H	L	L	L	L	H	BG	BA	V	V	Row address
WRITE	BL8 fixed, BC4 fixed	H	H	L	H	H	L	L	BG	BA	V	V	V
	BC4OTF	H	H	L	H	H	L	L	BG	BA	V	L	V
	BL8OTF	H	H	L	H	H	L	L	BG	BA	V	H	V
WRITE with auto precharge	BL8 fixed, BC4 fixed	H	H	L	H	H	L	L	BG	BA	V	V	V
	BC4OTF	H	H	L	H	H	L	L	BG	BA	V	L	V
	BL8OTF	H	H	L	H	H	L	L	BG	BA	V	H	V
READ	BL8 fixed, BC4 fixed	H	H	L	H	H	L	H	BG	BA	V	V	V
	BC4OTF	H	H	L	H	H	L	H	BG	BA	V	L	V
	BL8OTF	H	H	L	H	H	L	H	BG	BA	V	H	V
READ with auto precharge	BL8 fixed, BC4 fixed	H	H	L	H	H	L	H	BG	BA	V	V	V
	BC4OTF	H	H	L	H	H	L	H	BG	BA	V	L	V
	BL8OTF	H	H	L	H	H	L	H	BG	BA	V	H	V
NO OPERATION	NOP	H	H	L	H	H	H	V	V	V	V	V	
Device DESELECTED	DES	H	H	H	X	X	X	X	X	X	X	X	X
Power-down entry	PDE	H	L	H	X	X	X	X	X	X	X	X	X
Power-down exit	PDX	L	H	H	X	X	X	X	X	X	X	X	X
ZQ CALIBRATION LONG	ZQCL	H	H	L	H	H	H	L	X	X	X	X	X
ZQ CALIBRATION SHORT	ZQCS	H	H	L	H	H	H	L	X	X	X	X	X

- Notes:
- BG = Bank group address
  - BA = Bank address
  - RA = Row address
  - CA = Column address
  - BC<sub>n</sub> = Burst chop
  - X = "Don't Care"
  - V = Valid
- All DDR4 SDRAM commands are defined by states of CS<sub>n</sub>, ACT<sub>n</sub>, RAS<sub>n</sub>/A16, CAS<sub>n</sub>/A15, WE<sub>n</sub>/A14, and CKE at the rising edge of the clock. The MSB of BG, BA, RA, and CA are device density- and configuration-dependent. When ACT<sub>n</sub> = H, pins RAS<sub>n</sub>/A16, CAS<sub>n</sub>/A15, and WE<sub>n</sub>/A14 are used as command pins RAS<sub>n</sub>, CAS<sub>n</sub>, and WE<sub>n</sub>, respectively. When ACT<sub>n</sub> = L, pins RAS<sub>n</sub>/A16, CAS<sub>n</sub>/A15, and WE<sub>n</sub>/A14 are used as address pins A16, A15, and A14, respectively.
  - RESET<sub>n</sub> is enabled LOW and is used only for asynchronous reset and must be maintained HIGH during any function.
  - Bank group addresses (BG) and bank addresses (BA) determine which bank within a bank group is being operated upon. For MRS commands, the BG and BA selects the specific mode register location.
  - V means HIGH or LOW (but a defined logic level), and X means either defined or undefined (such as floating) logic level.
  - READ or WRITE bursts cannot be terminated or interrupted, and fixed/on-the-fly (OTF) BL will be defined by MRS.
  - During an MRS command, A17 is RFU and is device density- and configuration-dependent.
  - The state of ODT does not affect the states described in this table. The ODT function is not available during self refresh.
  - V<sub>PP</sub> and V<sub>REF</sub> (V<sub>REFCA</sub>) must be maintained during SELF REFRESH operation.
  - Refer to the Truth Table – CKE table for more details about CKE transition.
  - Controller guarantees self refresh exit to be synchronous. DRAM implementation has the choice of either synchronous or asynchronous.
  - The NO OPERATION (NOP) command may be used only when exiting maximum power saving mode or when entering gear-down mode.
  - The NOP command may not be used in place of the DESELECT command.
  - The power-down mode does not perform any REFRESH operation.

**Table 23: Truth Table – CKE**

Notes 1–7, 9, and 20 apply to the entire table

Current State	CKE		Command (n)	Action (n)	Notes
	Previous Cycle (n - 1)	Present Cycle (n)			
Power-down	L	L	X	Maintain power-down	8, 10, 11
	L	H	DES	Power-down exit	8, 10, 12
Self refresh	L	L	X	Maintain self refresh	11, 13
	L	H	DES	Self refresh exit	8, 13, 14, 15
Bank(s) active	H	L	DES	Active power-down entry	8, 10, 12, 16
Reading	H	L	DES	Power-down entry	8, 10, 12, 16, 17
Writing	H	L	DES	Power-down entry	8, 10, 12, 16, 17
Precharging	H	L	DES	Power-down entry	8, 10, 12, 16, 17
Refreshing	H	L	DES	Precharge power-down entry	8, 12
All banks idle	H	L	DES	Precharge power-down entry	8, 10, 12, 16, 18
	H	L	REFRESH	Self refresh	16, 18, 19

- Notes:
- Current state is defined as the state of the DDR4 SDRAM immediately prior to clock edge n.
  - CKE (n) is the logic state of CKE at clock edge n; CKE (n-1) was the state of CKE at the previous clock edge.
  - COMMAND (n) is the command registered at clock edge n, and ACTION (n) is a result of COMMAND (n); ODT is not included here.
  - All states and sequences not shown are illegal or reserved unless explicitly described elsewhere in this document.
  - The state of ODT does not affect the states described in this table. The ODT function is not available during self refresh.
  - During any CKE transition (registration of CKE H->L or CKE H->L), the CKE level must be maintained until 1 nCK prior to  $t_{CKE}^{(MIN)}$  being satisfied (at which time CKE may transition again).
  - DESELECT and NOP are defined in the Truth Table – Command table.
  - For power-down entry and exit parameters, see the Power-Down Modes section.
  - CKE LOW is allowed only if  $t_{MRD}$  and  $t_{MOD}$  are satisfied.
  - The power-down mode does not perform any REFRESH operations.
  - X = "Don't Care" (including floating around  $V_{REF}$ ) in self refresh and power-down. X also applies to address pins.
  - The Deselect command is the only valid command for power-down entry and exit.
  - $V_{PP}$  and  $V_{REFCA}$  must be maintained during SELF REFRESH operation.
  - On self refresh exit, the Deselect command must be issued on every clock edge occurring during the  $t_{XS}$  period. READ or ODT commands may be issued only after  $t_{XSDLL}$  is satisfied.
  - The Deselect command is the only valid command for self refresh exit.
  - Self refresh cannot be entered during READ or WRITE operations. For a detailed list of restrictions see the SELF REFRESH Operation and Power-Down Modes sections.
  - If all banks are closed at the conclusion of the READ, WRITE, or PRECHARGE command, then precharge power-down is entered; otherwise, active power-down is entered.

18. Idle state is defined as all banks are closed ( $t_{RP}$ ,  $t_{DAL}$ , and so on, satisfied), no data bursts are in progress, CKE is HIGH, and all timings from previous operations are satisfied ( $t_{MRD}$ ,  $t_{MOD}$ ,  $t_{RFC}$ ,  $t_{ZQinit}$ ,  $t_{ZQoper}$ ,  $t_{ZQCS}$ , and so on), as well as all self refresh exit and power-down exit parameters are satisfied ( $t_{XS}$ ,  $t_{XP}$ ,  $t_{XSDLL}$ , and so on).
19. Self refresh mode can be entered only from the all banks idle state.
20. For more details about all signals, see the Truth Table – Command table; must be a legal command as defined in the table.

## NOP Command

The NO OPERATION (NOP) command was originally used to instruct the selected DDR4 SDRAM to perform a NOP ( $CS_n = \text{LOW}$  and  $ACT_n$ ,  $RAS_n/A16$ ,  $CAS_n/A15$ , and  $WE_n/A14 = \text{HIGH}$ ). This prevented unwanted commands from being registered during idle or wait states. NOP command general support has been removed and the command should not be used unless specifically allowed, which is when exiting maximum power-saving mode or when entering gear-down mode.

## DESELECT Command

The deselect function ( $CS_n \text{ HIGH}$ ) prevents new commands from being executed; therefore, with this command, the device is effectively deselected. Operations already in progress are not affected.

## DLL-Off Mode

DLL-off mode is entered by setting MR1 bit A0 to 0, which will disable the DLL for subsequent operations until the A0 bit is set back to 1. The MR1 A0 bit for DLL control can be switched either during initialization or during self refresh mode. Refer to the Input Clock Frequency Change section for more details.

The maximum clock frequency for DLL-off mode is specified by the parameter  $t_{CKDLL\_OFF}$ . There is no minimum frequency limit besides the need to satisfy the refresh interval,  $t_{REFI}$ .

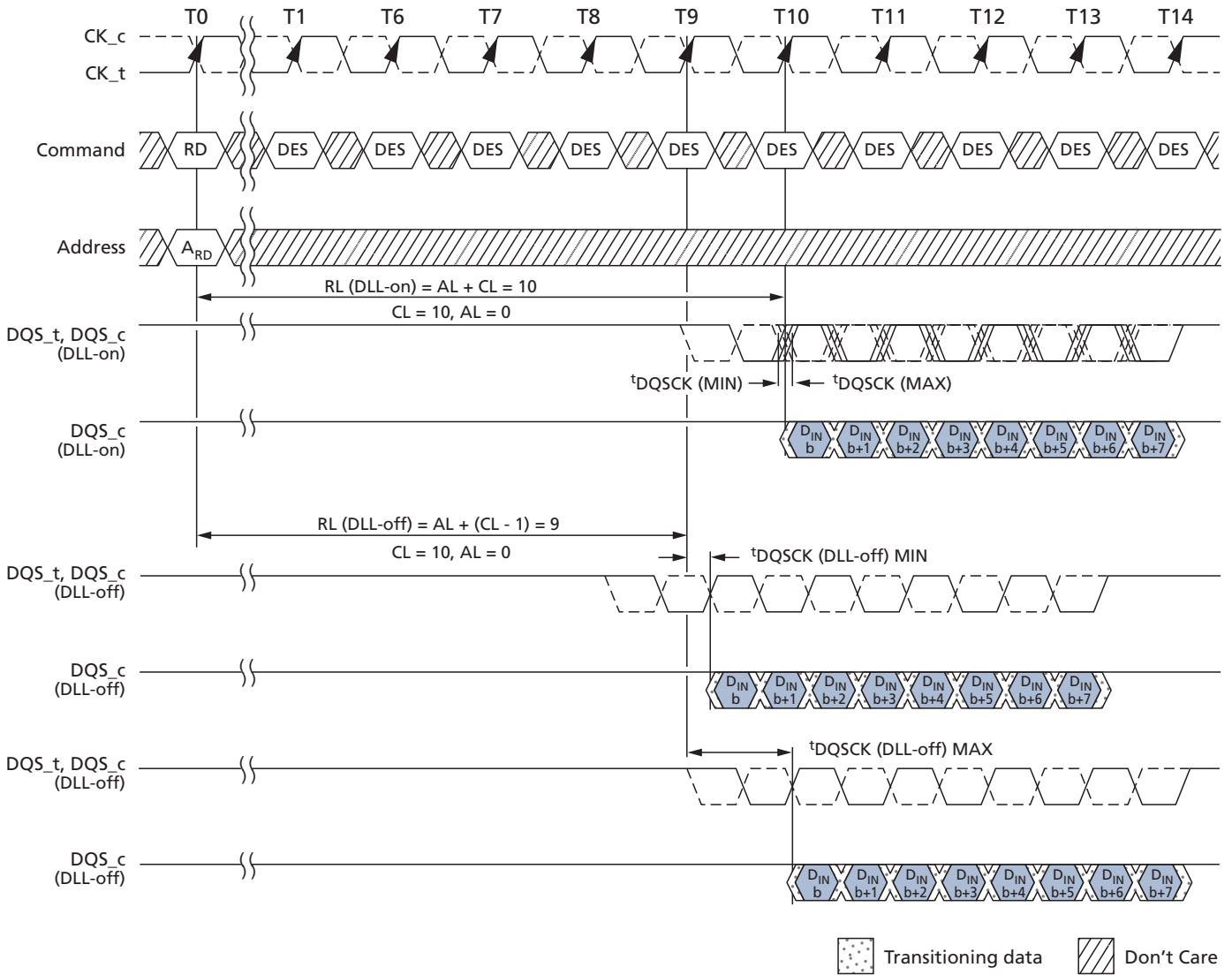
Due to latency counter and timing restrictions, only one CL value and CWL value (in MR0 and MR2 respectively) are supported. The DLL-off mode is only required to support setting both  $CL = 10$  and  $CWL = 9$ .

DLL-off mode will affect the read data clock-to-data strobe relationship ( $t_{DQSCK}$ ), but not the data strobe-to-data relationship ( $t_{DQSQ}$ ,  $t_{QH}$ ). Special attention is needed to line up read data to the controller time domain.

Compared with DLL-on mode, where  $t_{DQSCK}$  starts from the rising clock edge ( $AL + CL$ ) cycles after the READ command, the DLL-off mode  $t_{DQSCK}$  starts ( $AL + CL - 1$ ) cycles after the READ command. Another difference is that  $t_{DQSCK}$  may not be small compared to  $t_{CK}$  (it might even be larger than  $t_{CK}$ ), and the difference between  $t_{DQSCK}(\text{MIN})$  and  $t_{DQSCK}(\text{MAX})$  is significantly larger than in DLL-on mode. The  $t_{DQSCK}(\text{DLL-off})$  values are vendor-specific.

The timing relations on DLL-off mode READ operation are shown in the following diagram, where  $CL = 10$ ,  $AL = 0$ , and  $BL = 8$ .

Figure 12: DLL-Off Mode Read Timing Operation



## DLL-On/Off Switching Procedures

The DLL-off mode is entered by setting MR1 bit A0 to 0; this will disable the DLL for subsequent operations until the A0 bit is set back to 1.

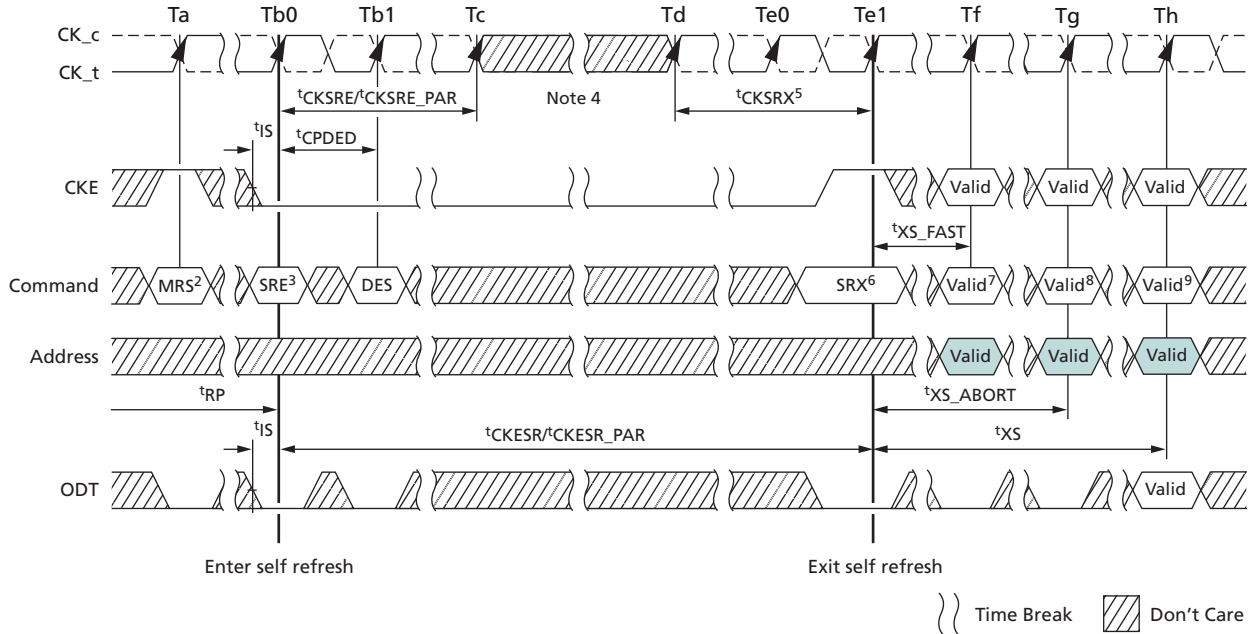
### DLL Switch Sequence from DLL-On to DLL-Off

To switch from DLL-on to DLL-off requires the frequency to be changed during self refresh, as outlined in the following procedure:

1. Starting from the idle state (all banks pre-charged, all timings fulfilled, and, to disable the DLL, the DRAM on-die termination resistors,  $R_{TT(NOM)}$ , must be in High-Z before MRS to MR1.)
2. Set MR1 bit A0 to 1 to disable the DLL.
3. Wait  $t_{MOD}$ .
4. Enter self refresh mode; wait until  $t_{CKSRE}/t_{CKSRE\_PAR}$  is satisfied.
5. Change frequency, following the guidelines in the Input Clock Frequency Change section.
6. Wait until a stable clock is available for at least  $t_{CKSRX}$  at device inputs.
7. Starting with the SELF REFRESH EXIT command, CKE must continuously be registered HIGH until all  $t_{MOD}$  timings from any MRS command are satisfied. In addition, if any ODT features were enabled in the mode registers when self refresh mode was entered, the ODT signal must continuously be registered LOW until all  $t_{MOD}$  timings from any MRS command are satisfied. If  $R_{TT(NOM)}$  was disabled in the mode registers when self refresh mode was entered, the ODT signal is "Don't Care."
8. Wait  $t_{XS\_FAST}$ ,  $t_{XS\_ABORT}$ , or  $t_{XS}$ , and then set mode registers with appropriate values (an update of CL, CWL, and WR may be necessary; a ZQCL command can also be issued after  $t_{XS\_FAST}$ ).
  - $t_{XS\_FAST}$ : ZQCL, ZQCS, and MRS commands. For MRS commands, only CL and WR/RTP registers in MR0, the CWL register in MR2, and gear-down mode in MR3 may be accessed provided the device is not in per-DRAM addressability mode. Access to other device mode registers must satisfy  $t_{XS}$  timing.
  - $t_{XS\_ABORT}$ : If the bit is enabled, then the device aborts any ongoing refresh and does not increment the refresh counter. The controller can issue a valid command after a delay of  $t_{XS\_ABORT}$ . Upon exiting from self refresh, the device requires a minimum of one extra REFRESH command before it is put back into self refresh mode. This requirement remains the same regardless of the MRS bit setting for self refresh abort.
  - $t_{XS}$ : ACT, PRE, PREA, REF, SRE, PDE, WR, WRS4, WRS8, WRA, WRAS4, WRAS8, RD, RDS4, RDS8, RDA, RDAS4, and RDAS8.
9. Wait  $t_{MOD}$  to complete.

The device is ready for the next command.

**Figure 13: DLL Switch Sequence from DLL-On to DLL-Off**



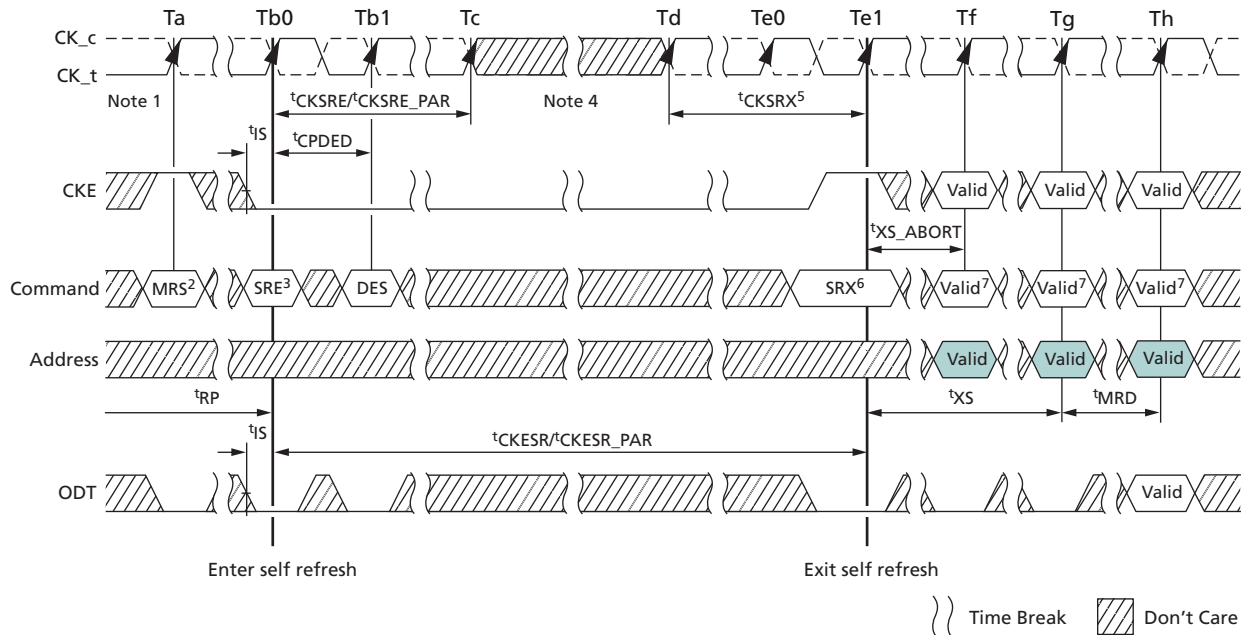
- Notes:
1. Starting in the idle state.  $R_{TT}$  in stable state.
  2. Disable DLL by setting MR1 bit A0 to 0.
  3. Enter SR.
  4. Change frequency.
  5. Clock must be stable  $t_{CKSRX}$ .
  6. Exit SR.
  7. Update mode registers allowed with DLL-off settings met.

**DLL-Off to DLL-On Procedure**

- To switch from DLL-off to DLL-on (with required frequency change) during self refresh:
1. Starting from the idle state (all banks pre-charged, all timings fulfilled, and DRAM ODT resistors ( $R_{TT(NOM)}$ ) must be in High-Z before self refresh mode is entered.)
  2. Enter self refresh mode; wait until  $t_{CKSRE}/t_{CKSRE\_PAR}$  are satisfied.
  3. Change frequency (following the guidelines in the Input Clock Frequency Change section).
  4. Wait until a stable clock is available for at least  $t_{CKSRX}$  at device inputs.
  5. Starting with the SELF REFRESH EXIT command, CKE must continuously be registered HIGH until  $t_{DLLK}$  timing from the subsequent DLL RESET command is satisfied. In addition, if any ODT features were enabled in the mode registers when self refresh mode was entered, the ODT signal must continuously be registered LOW or HIGH until  $t_{DLLK}$  timing from the subsequent DLL RESET command is satisfied. If  $R_{TT(NOM)}$  disabled in the mode registers when self refresh mode was entered, the ODT signal is "Don't Care."
  6. Wait  $t_{XS}$  or  $t_{XS\_ABORT}$ , depending on bit  $x$  in  $RM_y$ , then set MR1 bit A0 to 0 to enable the DLL.
  7. Wait  $t_{MRD}$ , then set MR1 bit A8 to 1 to start DLL reset.
  8. Wait  $t_{MRD}$ , then set mode registers with appropriate values; an update of CL, CWL, and WR may be necessary. After  $t_{MOD}$  is satisfied from any proceeding MRS command, a ZQCL command can also be issued during or after  $t_{DLLK}$ .
  9. Wait for  $t_{MOD}$  to complete. Remember to wait  $t_{DLLK}$  after DLL RESET before applying any command requiring a locked DLL. In addition, wait for  $t_{ZQoper}$  in case a ZQCL command was issued.

The device is ready for the next command.

**Figure 14: DLL Switch Sequence from DLL-Off to DLL-On**



Notes: 1. Starting in the idle state.

2. Enter SR.
3. Change frequency.
4. Clock must be stable  $t_{CKSRX}$ .
5. Exit SR.
6. Set DLL to on by setting MR1 to A0 = 0.
7. Update mode registers.
8. Issue any valid command.

## Input Clock Frequency Change

After the device is initialized, it requires the clock to be stable during almost all states of normal operation. This means that after the clock frequency has been set and is in the stable state, the clock period is not allowed to deviate except for what is allowed by the clock jitter and spread spectrum clocking (SSC) specifications. The input clock frequency can be changed from one stable clock rate to another stable clock rate only when in self refresh mode. Outside of self refresh mode, it is illegal to change the clock frequency.

After the device has been successfully placed in self refresh mode and  $t_{CKSRE}/t_{CKSRE\_PAR}$  have been satisfied, the state of the clock becomes a "Don't Care." Following a "Don't Care," changing the clock frequency is permissible, provided the new clock frequency is stable prior to  $t_{CKSRX}$ . When entering and exiting self refresh mode for the sole purpose of changing the clock frequency, the self refresh entry and exit specifications must still be met as outlined in SELF REFRESH Operation.

For the new clock frequency, additional MRS commands to MR0, MR2, MR3, MR4, and MR6 may need to be issued to program appropriate CL, CWL, gear-down mode, READ and WRITE preamble, and  $t_{CCD\_L}/t_{DLLK}$  values. If MR6 is issued prior to self refresh entry for new the  $t_{DLLK}$  value, DLL will relock automatically at self refresh exit. However, if MR6 is issued after self refresh entry, MR0 must be issued to reset the DLL.

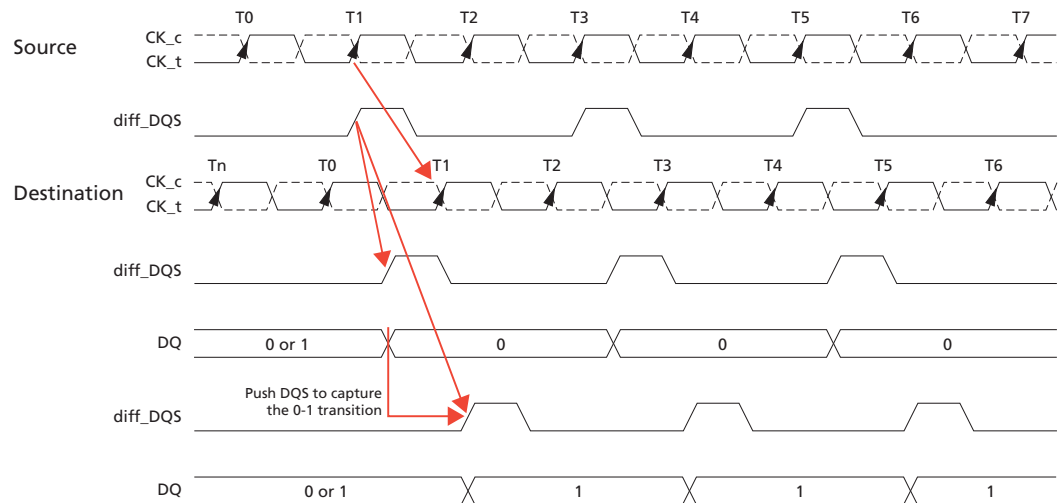
The device input clock frequency can change only within the minimum and maximum operating frequency specified for the particular speed grade. Any frequency change below the minimum operating frequency would require the use of DLL-on mode to DLL-off mode transition sequence (see DLL-On/Off Switching Procedures).

## Write Leveling

For better signal integrity, DDR4 memory modules use fly-by topology for the commands, addresses, control signals, and clocks. Fly-by topology has benefits from the reduced number of stubs and their length, but it also causes flight-time skew between clock and strobe at every DRAM on the DIMM. This makes it difficult for the controller to maintain  $t_{DQSS}$ ,  $t_{DSS}$ , and  $t_{DSH}$  specifications. Therefore, the device supports a write-leveling feature to allow the controller to compensate for skew. This feature may not be required under some system conditions, provided the host can maintain the  $t_{DQSS}$ ,  $t_{DSS}$ , and  $t_{DSH}$  specifications.

The memory controller can use the write-leveling feature and feedback from the device to adjust the DQS (DQS<sub>t</sub>, DQS<sub>c</sub>) to CK (CK<sub>t</sub>, CK<sub>c</sub>) relationship. The memory controller involved in the leveling must have an adjustable delay setting on DQS to align the rising edge of DQS with that of the clock at the DRAM pin. The DRAM asynchronously feeds back CK, sampled with the rising edge of DQS, through the DQ bus. The controller repeatedly delays DQS until a transition from 0 to 1 is detected. The DQS delay established through this exercise would ensure the  $t_{DQSS}$  specification. Besides  $t_{DQSS}$ ,  $t_{DSS}$  and  $t_{DSH}$  specifications also need to be fulfilled. One way to achieve this is to combine the actual  $t_{DQSS}$  in the application with an appropriate duty cycle and jitter on the DQS signals. Depending on the actual  $t_{DQSS}$  in the application, the actual values for  $t_{DQSL}$  and  $t_{DQSH}$  may have to be better than the absolute limits provided in the AC Timing Parameters section in order to satisfy  $t_{DSS}$  and  $t_{DSH}$  specifications. A conceptual timing of this scheme is shown below.

**Figure 15: Write-Leveling Concept, Example 1**

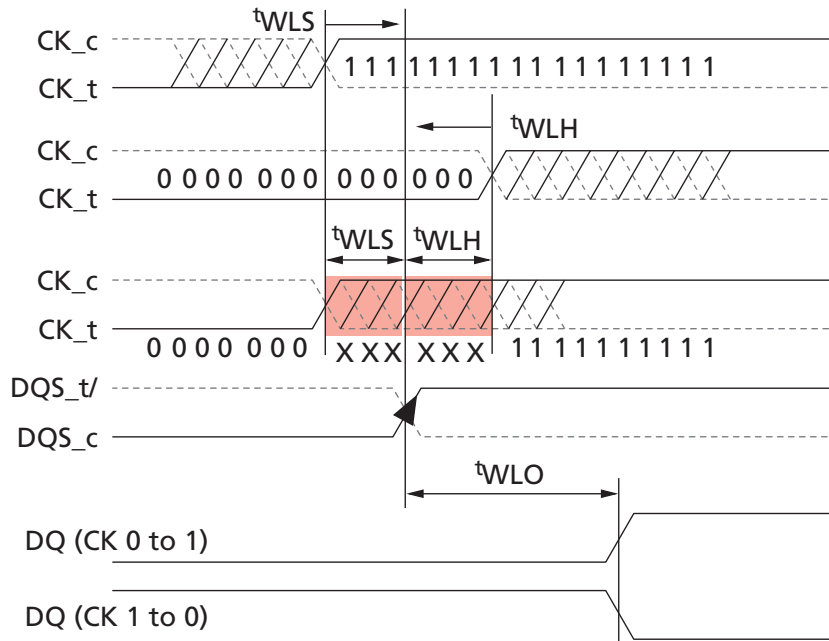


DQS driven by the controller during leveling mode must be terminated by the DRAM based on the ranks populated. Similarly, the DQ bus driven by the DRAM must also be terminated at the controller.

All data bits carry the leveling feedback to the controller across the DRAM configurations: x4, x8, and x16. On a x16 device, both byte lanes should be leveled independently. Therefore, a separate feedback mechanism should be available for each byte lane. The upper data bits should provide the feedback of the upper diff\_DQS(diff\_UDQS)-to-clock relationship; the lower data bits would indicate the lower diff\_DQS(diff\_LDQS)-to-clock relationship.

The figure below is another representative way to view the write-leveling procedure. Although it shows the clock varying to a static strobe, this is for illustrative purpose only; the clock does not actually change phase, the strobe is what actually varies. By issuing multiple WL bursts, the DQS strobe can be varied to capture with fair accuracy the time at which the clock edge arrives at the DRAM clock input buffer.

**Figure 16: Write-Leveling Concept, Example 2**



**DRAM Setting for Write Leveling and DRAM TERMINATION Function in that Mode**

The DRAM enters into write-leveling mode if A7 in MR1 is HIGH. When leveling is finished, the DRAM exits write-leveling mode if A7 in MR1 is LOW (see the MR Leveling Procedures table). Note that in write-leveling mode, only DQS terminations are activated and deactivated via the ODT pin, unlike normal operation (see DRAM DRAM TERMINATION Function in Leveling Mode table).

**Table 24: MR Settings for Leveling Procedures**

Function	MR1	Enable	Disable
Write leveling enable	A7	1	0
Output buffer mode (Q off)	A12	0	1

**Table 25: DRAM TERMINATION Function in Leveling Mode**

ODT Pin at DRAM	DQS_t/DQS_c Termination	DQ Termination
R <sub>TT(NOM)</sub> with ODT HIGH	On	Off

**Table 25: DRAM TERMINATION Function in Leveling Mode (Continued)**

ODT Pin at DRAM	DQS_t/DQS_c Termination	DQ Termination
R <sub>TT(Park)</sub> with ODT LOW	On	Off

- Notes:
1. In write-leveling mode, with the mode's output buffer either disabled (MR1[bit7] = 1 and MR1[bit12] = 1) or with its output buffer enabled (MR1[bit7] = 1 and MR1[bit12] = 0), all R<sub>TT(NOM)</sub> and R<sub>TT(Park)</sub> settings are supported.
  2. R<sub>TT(WR)</sub> is not allowed in write-leveling mode and must be set to disable prior to entering write-leveling mode.

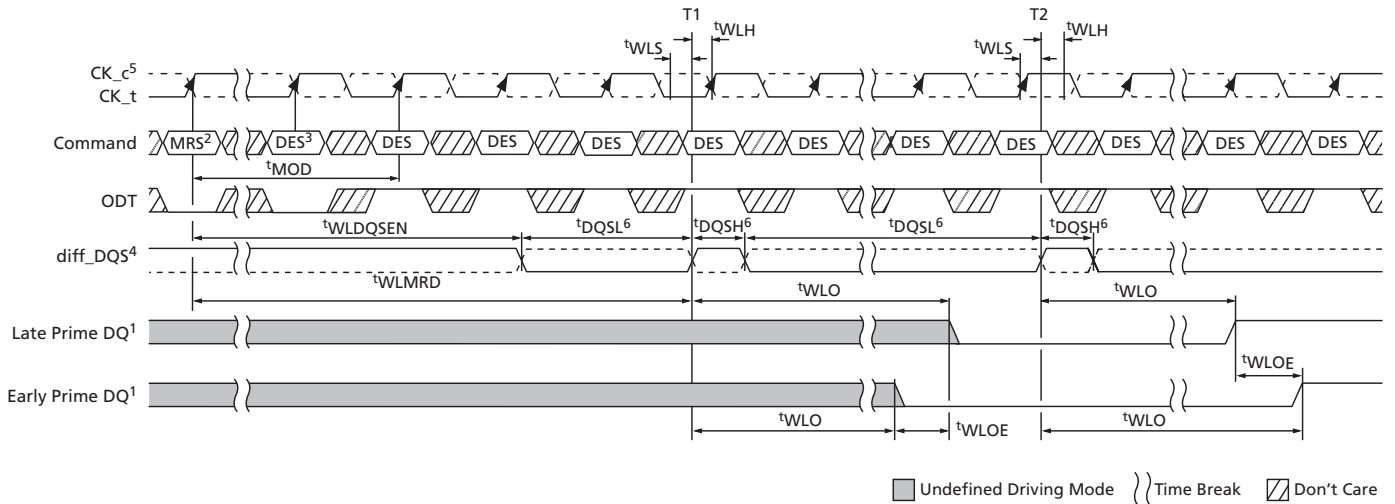
## Procedure Description

The memory controller initiates the leveling mode of all DRAM by setting bit 7 of MR1 to 1. When entering write-leveling mode, the DQ pins are in undefined driving mode. During write-leveling mode, only the DESELECT command is supported, other than MRS commands to change the Qoff bit (MR1[A12]) and to exit write leveling (MR1[A7]). Upon exiting write-leveling mode, the MRS command performing the exit (MR1[A7] = 0) may also change the MR1 bits of TBD. Because the controller levels one rank at a time, the output of other ranks must be disabled by setting MR1 bit A12 to 1. The controller may assert ODT after <sup>t</sup>MOD, at which time the DRAM is ready to accept the ODT signal.

The controller may drive DQS<sub>t</sub> LOW and DQS<sub>c</sub> HIGH after a delay of <sup>t</sup>WLDQSEN, at which time the DRAM has applied ODT to these signals. After <sup>t</sup>DQSL and <sup>t</sup>WLMRD, the controller provides a single DQS<sub>t</sub>, DQS<sub>c</sub> edge, which is used by the DRAM to sample CK driven from the controller. <sup>t</sup>WLMRD (MAX) timing is controller dependent.

The DRAM samples CK status with the rising edge of DQS and provides feedback on all the DQ bits asynchronously after <sup>t</sup>WLO timing. There is a DQ output uncertainty of <sup>t</sup>WLOE defined to allow mismatch on DQ bits. The <sup>t</sup>WLOE period is defined from the transition of the earliest DQ bit to the corresponding transition of the latest DQ bit. There are no read strobcs (DQS<sub>t</sub>, DQS<sub>c</sub>) needed for these DQs. The controller samples incoming DQ and either increments or decrements DQS delay setting and launches the next DQS pulse after some time, which is controller dependent. After a 0-to-1 transition is detected, the controller locks the DQS delay setting, and write leveling is achieved for the device. The following figure shows the timing diagram and parameters for the overall write-leveling procedure.

**Figure 17: Write-Leveling Sequence (DQS Capturing CK LOW at T1 and CK HIGH at T2)**



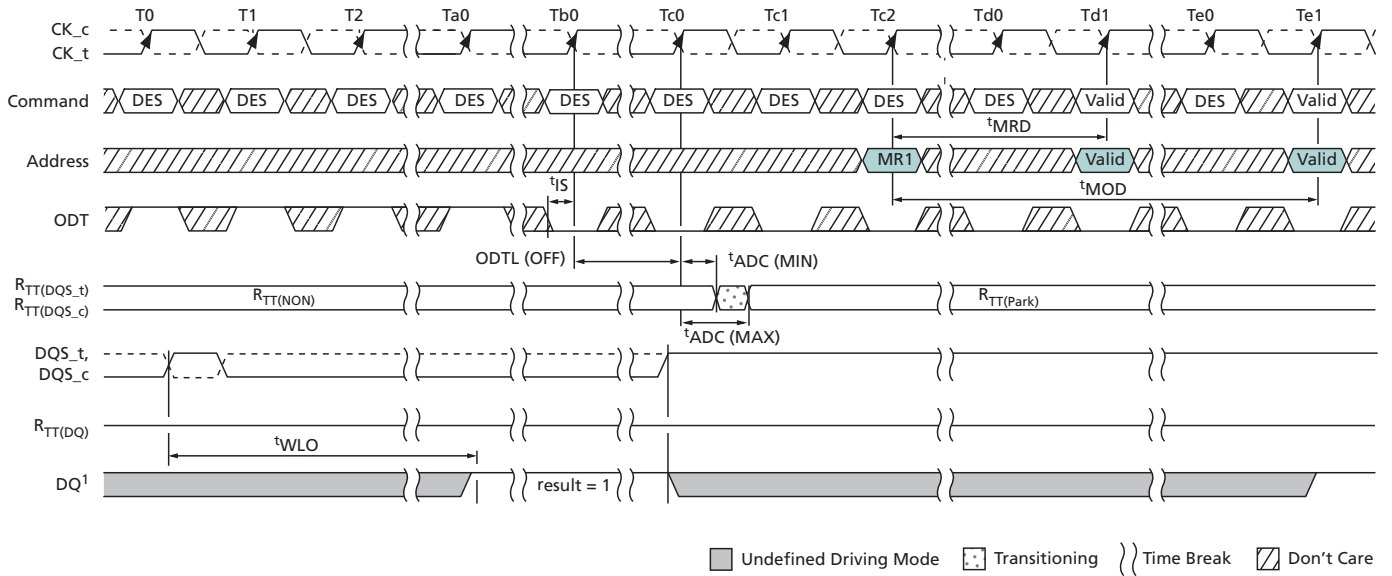
- Notes:
1. The device drives leveling feedback on all DQs.
  2. MRS: Load MR1 to enter write-leveling mode.
  3. diff\_DQS is the differential data strobe. Timing reference points are the zero crossings. DQS\_t is shown with a solid line; DQS\_c is shown with a dotted line.
  4. CK\_t is shown with a solid dark line; CK\_c is shown with a dotted line.
  5. DQS needs to fulfill minimum pulse width requirements,  $t_{DQSH}$  (MIN) and  $t_{DQSL}$  (MIN), as defined for regular WRITES; the maximum pulse width is system dependent.
  6.  $t_{WLDQSEN}$  must be satisfied following equation when using ODT:
    - DLL = Enable, then  $t_{WLDQSEN} > t_{MOD} (MIN) + ODT_{Lon} + t_{ADC}$
    - DLL = Disable, then  $t_{WLDQSEN} > t_{MOD} (MIN) + t_{AONAS}$

## Write-Leveling Mode Exit

Write-leveling mode should be exited as follows:

1. After the last rising strobe edge (see  $\sim T0$ ), stop driving the strobe signals (see  $\sim Tc0$ ). Note that from this point on, DQ pins are in undefined driving mode and will remain undefined, until  $t_{MOD}$  after the respective MR command ( $T_{e1}$ ).
2. Drive ODT pin LOW ( $t_{IS}$  must be satisfied) and continue registering LOW (see  $T_{b0}$ ).
3. After  $R_{TT}$  is switched off, disable write-leveling mode via the MRS command (see  $T_{c2}$ ).
4. After  $t_{MOD}$  is satisfied ( $T_{e1}$ ), any valid command can be registered. (MR commands can be issued after  $t_{MRD}$  [ $T_{d1}$ ]).

Figure 18: Write-Leveling Exit

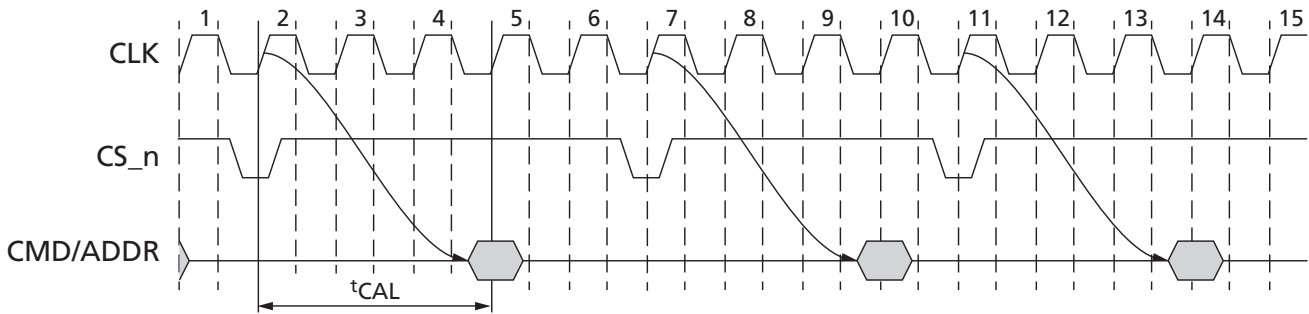


- Notes:
1. The DQ result = 1 between  $Ta_0$  and  $Tc_0$  is a result of the DQS signals capturing CK\_t HIGH just after the  $T_0$  state.
  2. See previous figure for specific  $t_{WLO}$  timing.

## Command Address Latency

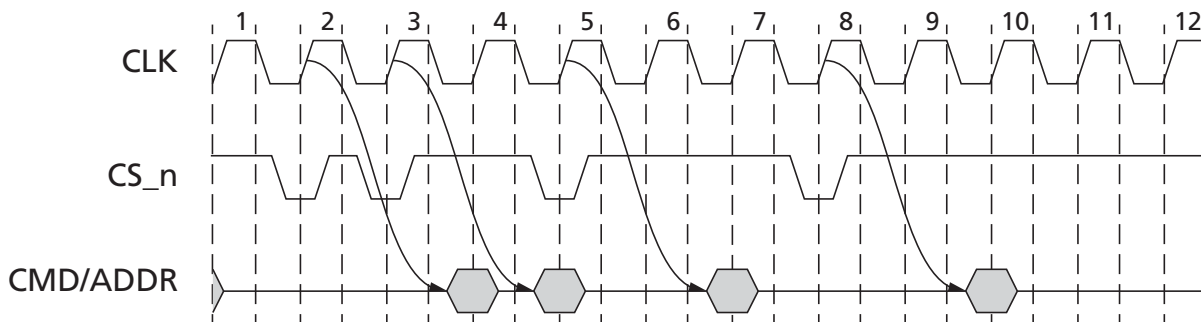
DDR4 supports the command address latency (CAL) function as a power savings feature. This feature can be enabled or disabled via the MRS setting. CAL timing is defined as the delay in clock cycles ( $t_{CAL}$ ) between a CS<sub>n</sub> registered LOW and its corresponding registered command and address. The value of CAL in clocks must be programmed into the mode register (see MR1 Register Definition table) and is based on the equation  $t_{CK}(ns)/t_{CAL}(ns)$ , rounded up in clocks.

**Figure 19: CAL Timing Definition**



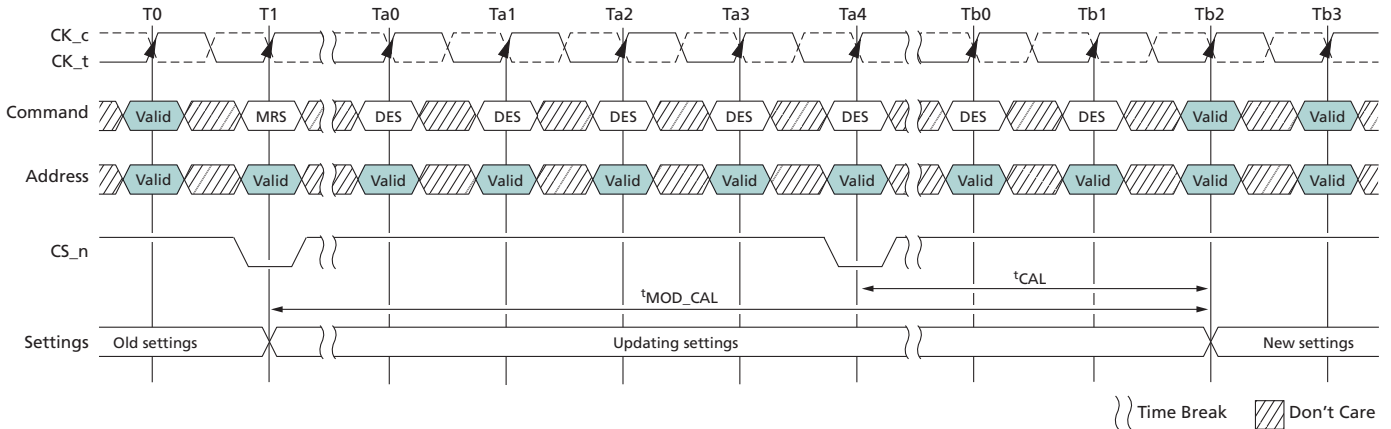
CAL gives the DRAM time to enable the command and address receivers before a command is issued. After the command and the address are latched, the receivers can be disabled if CS<sub>n</sub> returns to HIGH. For consecutive commands, the DRAM will keep the command and address input receivers enabled for the duration of the command sequence.

**Figure 20: CAL Timing Example (Consecutive CS<sub>n</sub> = LOW)**



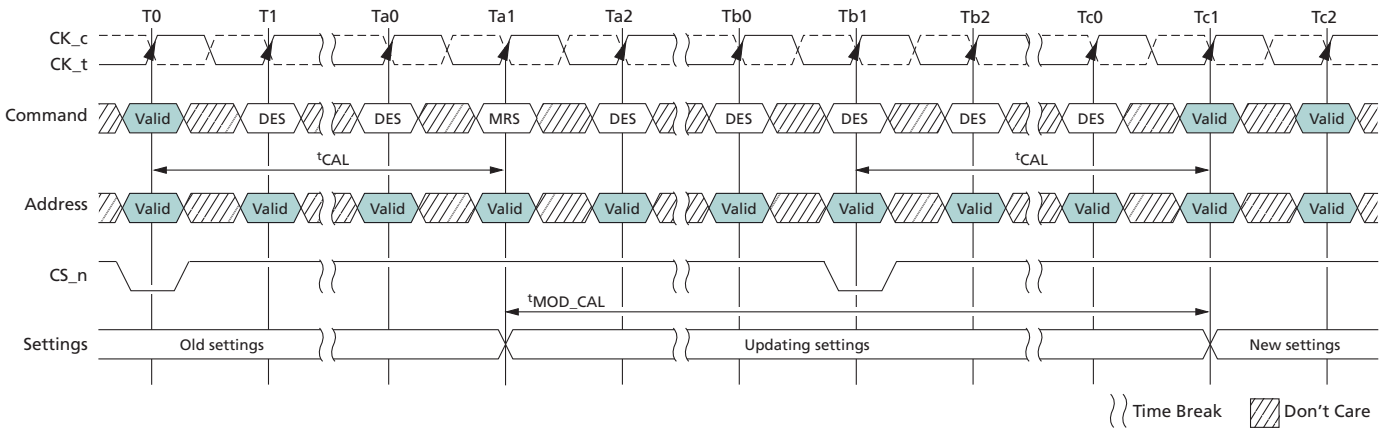
When the CAL mode is enabled, additional time is required for the MRS command to complete. The earliest the next valid command can be issued is  $t_{MOD\_CAL}$ , which should be equal to  $t_{MOD} + t_{CAL}$ . The two following figures are examples.

**Figure 21: CAL Enable Timing –  $t_{MOD\_CAL}$**



Note: 1. CAL mode is enabled at  $T_1$ .

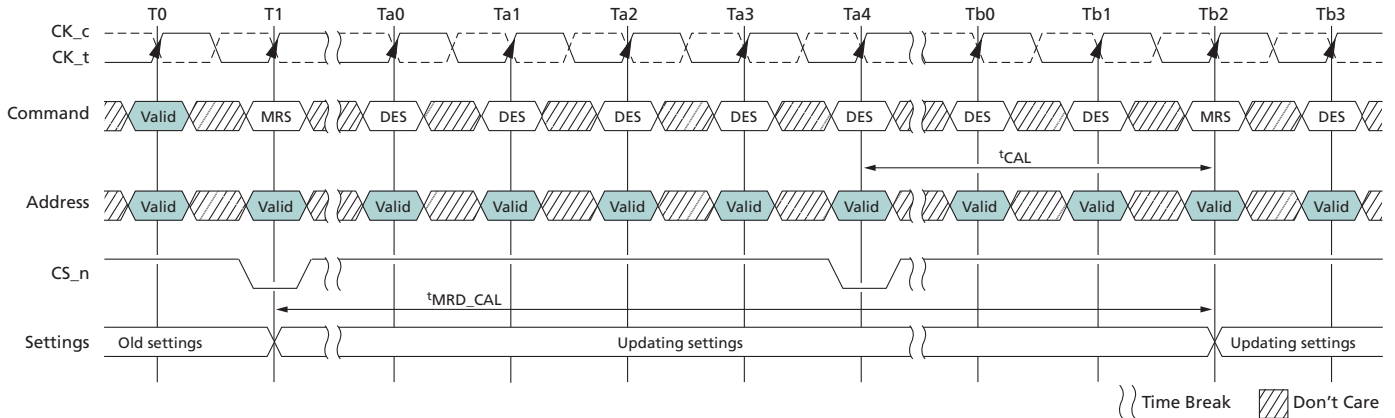
**Figure 22:  $t_{MOD\_CAL}$ , MRS to Valid Command Timing with CAL Enabled**



Note: 1. MRS at  $T_{a1}$  may or may not modify CAL,  $t_{MOD\_CAL}$  is computed based on new  $t_{CAL}$  setting if modified.

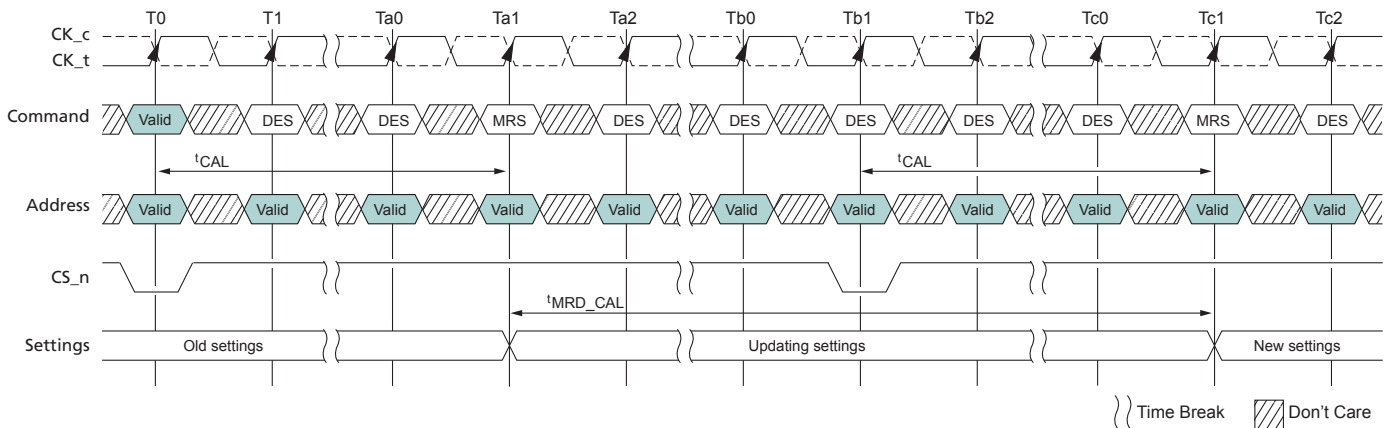
When the CAL mode is enabled or being enabled, the earliest the next MRS command can be issued is  $t^{MRD\_CAL}$  is equal to  $t^{MOD} + t^{CAL}$ . The two following figures are examples.

**Figure 23: CAL Enabling MRS to Next MRS Command,  $t^{MRD\_CAL}$**



Note: 1. Command address latency mode is enabled at T1.

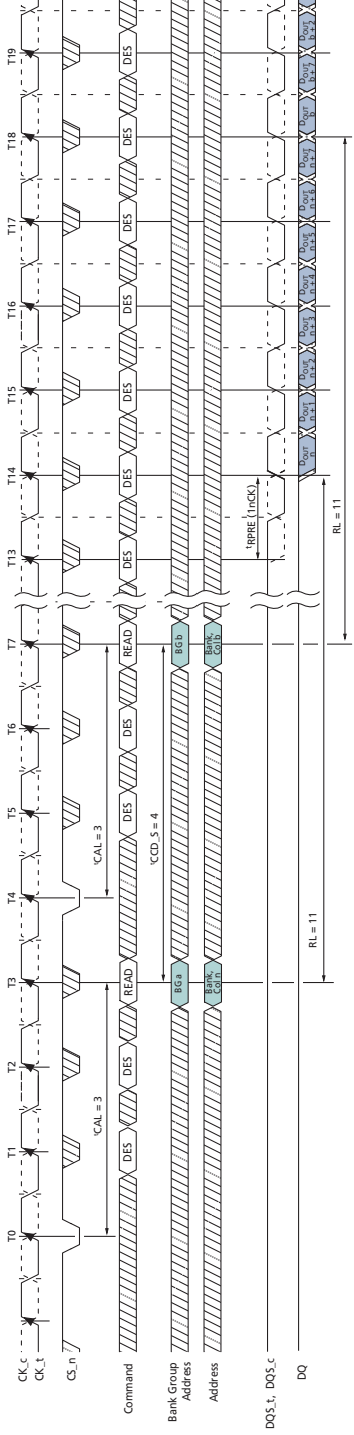
**Figure 24:  $t^{MRD\_CAL}$ , Mode Register Cycle Time With CAL Enabled**



Note: 1. MRS at Ta1 may or may not modify CAL,  $t^{MRD\_CAL}$  is computed based on new  $t^{CAL}$  setting if modified.

CAL Examples: Consecutive READ BL8 with two different CALs and  $1^{tCK}$  preamble in different bank group shown in the following figures.

**Figure 25: Consecutive READ BL8, CAL3, 1tCK Preamble, Different Bank Group**



**Notes:** 1. BL = 8, AL = 0, CL = 11, CAL = 3, Preamble = 1tCK.

2. D<sub>OUT</sub> n = data-out from column n; D<sub>OUT</sub> b = data-out from column b.

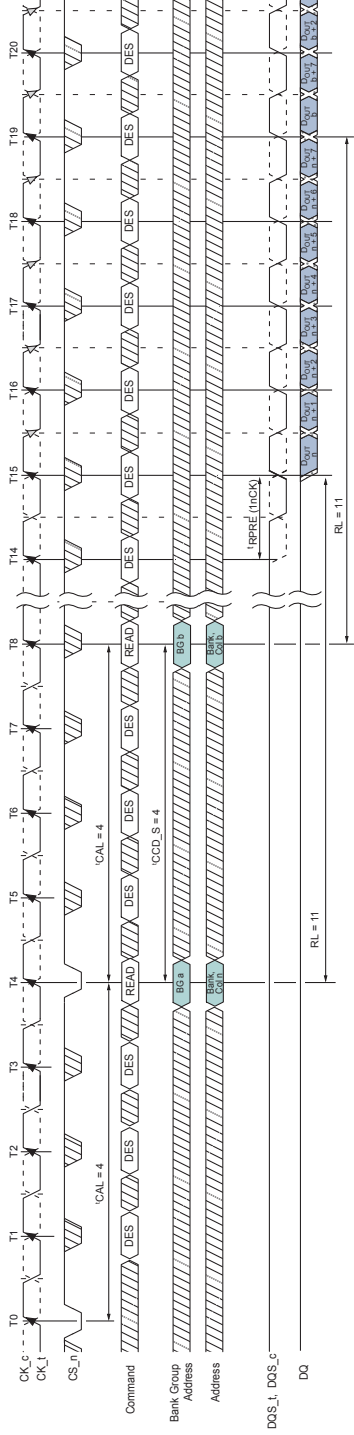
3. DES commands are shown for ease of illustration, other commands may be valid at these times.

4. BL8 setting activated by either MR0[A1:0 = 00] or MR0[A1:0 = 01] and A12 = 1 during READ command.

5. CA parity = Disable, CS to CA latency = Enable, Read DBI = Disable.

6. Enabling CAL mode does not impact ODT control timings. ODT control timings should be maintained the same timing relationship relative to the command/address bus as when CAL is disabled.

**Figure 26: Consecutive READ BL8, CAL4, 1tCK Preamble, Different Bank Group**



**Notes:** 1. BL = 8, AL = 0, CL = 11, CAL = 4, Preamble = 1tCK.

2. D<sub>OUT</sub> n = data-out from column n; D<sub>OUT</sub> b = data-out from column b.

3. DES commands are shown for ease of illustration, other commands may be valid at these times.

4. BL8 setting activated by either MR0[A1:0 = 00] or MR0[A1:0 = 01] and A12 = 1 during READ command.

5. CA parity = Disable, CS to CA latency = Enable, Read DBI = Disable.
6. Enabling CAL mode does not impact ODT control timings. ODT control timings should be maintained the same timing relationship relative to the command/address bus as when CAL is disabled.

## Low-Power Auto Self Refresh Mode

An auto self refresh mode is provided for application ease. Auto self refresh mode is enabled by setting MR2[6] = 1 and MR2[7] = 1. The device will manage self refresh entry over the supported temperature range of the DRAM. In this mode, the device will change its self refresh rate as the DRAM operating temperature changes, going lower at low temperatures and higher at high temperatures.

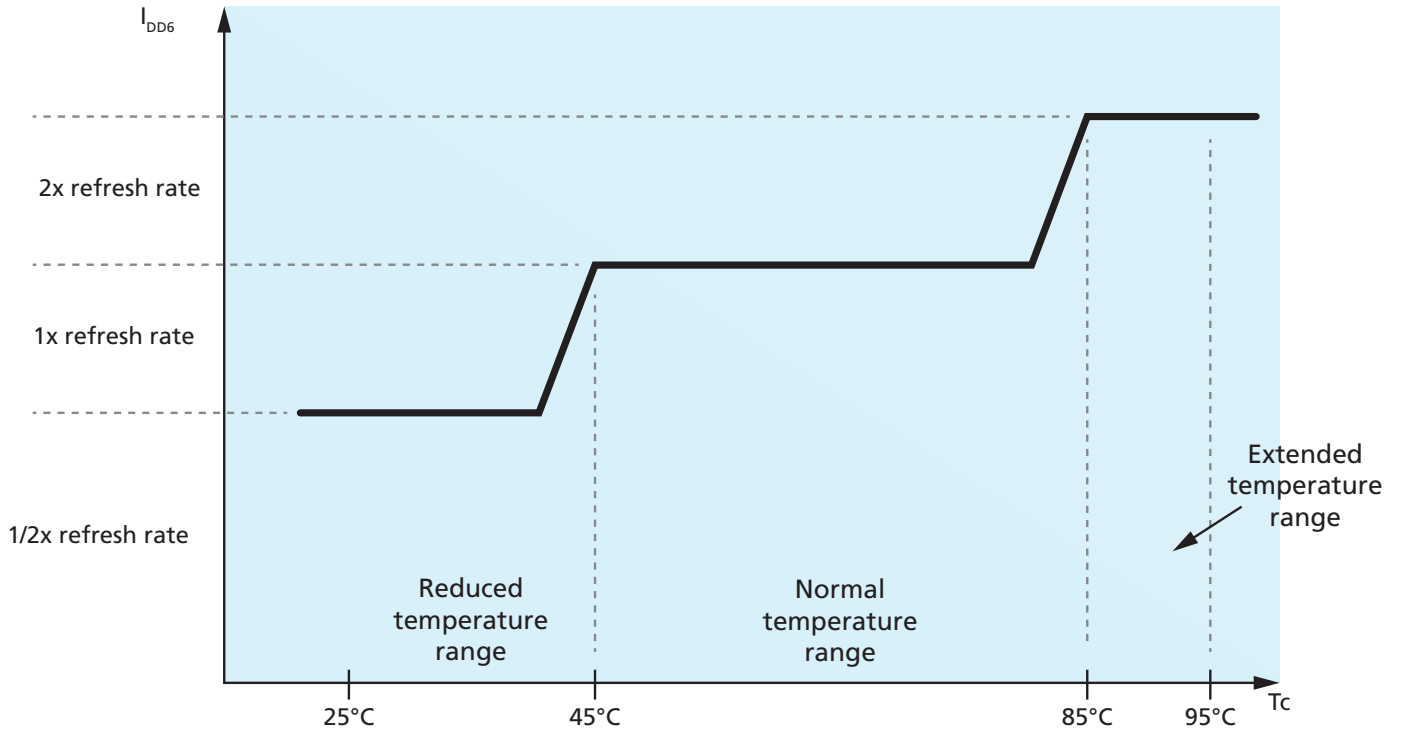
## Manual Self Refresh Mode

If auto self refresh mode is not enabled, the low-power auto self refresh mode register must be manually programmed to one of the three self refresh operating modes. This mode provides the flexibility to select a fixed self refresh operating mode at the entry of the self refresh, according to the system memory temperature conditions. The user is responsible for maintaining the required memory temperature condition for the mode selected during the SELF REFRESH operation. The user may change the selected mode after exiting self refresh and before entering the next self refresh. If the temperature condition is exceeded for the mode selected, there is a risk to data retention resulting in loss of data.

**Table 26: Auto Self Refresh Mode**

MR2[7]	MR2[6]	Low-Power Auto Self Refresh Mode	SELF REFRESH Operation	Operating Temperature Range for Self Refresh Mode (DRAM T <sub>CASE</sub> )
0	0	Normal	Fixed normal self refresh rate maintains data retention at the normal operating temperature. User is required to ensure that 85°C DRAM T <sub>CASE</sub> (MAX) is not exceeded to avoid any risk of data loss.	0°C to 85°C
1	0	Extended temperature	Fixed high self refresh rate optimizes data retention to support the extended temperature range.	0°C to 95°C
0	1	Reduced temperature	Variable or fixed self refresh rate or any other DRAM power consumption reduction control for the reduced temperature range. User is required to ensure 45°C DRAM T <sub>CASE</sub> (MAX) is not exceeded to avoid any risk of data loss.	0°C to 45°C
1	1	Auto self refresh	Auto self refresh mode enabled. Self refresh power consumption and data retention are optimized for any given operating temperature condition.	All of the above

**Figure 27: Auto Self Refresh Ranges**

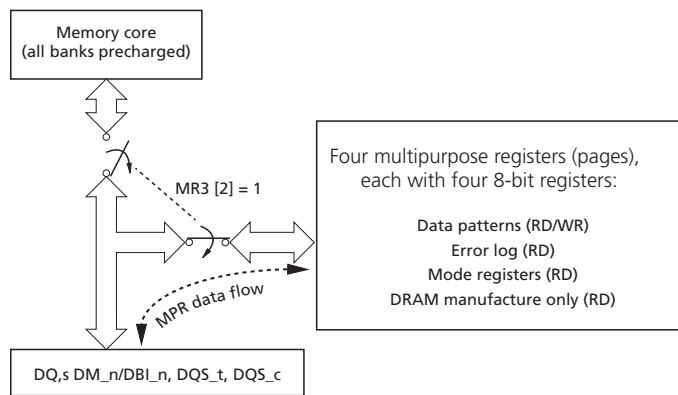


## Multipurpose Register

The MULTIPURPOSE REGISTER (MPR) function, MPR access mode, is used to write/read specialized data to/from the DRAM. The MPR consists of four logical pages, MPR Page 0 through MPR Page 3, with each page having four 8-bit registers, MPR0 through MPR3. Page 0 can be read by any of three readout modes (serial, parallel, or staggered) while Pages 1, 2, and 3 can be read by only the serial readout mode. Page 3 is for DRAM vendor use only. MPR mode enable and page selection is done with MRS commands. Data bus inversion (DBI) is not allowed during MPR READ operation.

Once the MPR access mode is enabled (MR3[2] = 1), only the following commands are allowed: MRS, RD, RDA WR, WRA, DES, REF, and RESET; RDA/WRA have the same functionality as RD/WR which means the auto precharge part of RDA/WRA is ignored. Power-down mode and SELF REFRESH command are not allowed during MPR enable mode. No other command can be issued within tRFC after a REF command has been issued; 1x refresh (only) is to be used during MPR access mode. While in MPR access mode, MPR read or write sequences must be completed prior to a REFRESH command.

**Figure 28: MPR Block Diagram**



**Table 27: MR3 Setting for the MPR Access Mode**

Address	Operation Mode	Description
A[12:11]	MPR data read format	00 = Serial ..... 01 = Parallel 10 = Staggered .... 11 = Reserved
A2	MPR access	0 = Standard operation (MPR not enabled) 1 = MPR data flow enabled
A[1:0]	MPR page selection	00 = Page 0 .... 01 = Page 1 10 = Page 2 .... 11 = Page 3

**Table 28: DRAM Address to MPR UI Translation**

MPR Location	[7]	[6]	[5]	[4]	[3]	[2]	[1]	[0]
DRAM address – Ax	A7	A6	A5	A4	A3	A2	A1	A0
MPR UI – UIx	UI0	UI1	UI2	UI3	UI4	UI5	UI6	UI7

**Table 29: MPR Page and MPRx Definitions**

Address	MPR Location	[7]	[6]	[5]	[4]	[3]	[2]	[1]	[0]	Note
<b>MPR Page 0 – Read or Write (Data Patterns)</b>										
BA[1:0]	00 = MPR0	0	1	0	1	0	1	0	1	Read/Write (default value listed)
	01 = MPR1	0	0	1	1	0	0	1	1	
	10 = MPR2	0	0	0	0	1	1	1	1	
	11 = MPR3	0	0	0	0	0	0	0	0	
<b>MPR Page 1 – Read-only (Error Log)</b>										
BA[1:0]	00 = MPR0	A7	A6	A5	A4	A3	A2	A1	A0	Read-only
	01 = MPR1	CAS_n/A15	WE_n/A14	A13	A12	A11	A10	A9	A8	
	10 = MPR2	PAR	ACT_n	BG1	BG0	BA1	BA0	A17	RAS_n/A16	
	11 = MPR3	CRC error status	CA parity error status	CA parity latency: [5] = MR5[2], [4] = MR5[1], [3] = MR5[0]			C2	C1	C0	
<b>MPR Page 2 – Read-only (MRS Readout)</b>										
BA[1:0]	00 = MPR0	PPR support	sPPR support	R <sub>TT(WR)</sub>	Temperature sensor status <sup>2</sup>	CRC write enable	R <sub>TT(WR)</sub>		Read-only	
	01 = MPR1	V <sub>REFDQ</sub> trainging range	V <sub>REFDQ</sub> training value: [6:1] = MR6[5:0]					Gear-down enable		
	CAS latency: [7:3] = MR0[12,6:4,2] 10 = MPR2					CAS write latency [2:0] = MR2[5:3]				
	11 = MPR3	R <sub>TT(NOM)</sub> : [7:5] = MR1[10:8]			R <sub>TT(Park)</sub> : [4:2] = MR5[8:6]		R <sub>ON</sub> : [1:0] = MR2[2:1]			
<b>MPR Page 3 – Read-only (Restricted, except for MPR3 [3:0])</b>										
BA[1:0]	00 = MPR0	DC	DC	DC	DC	DC	DC	DC	DC	Read-only
	01 = MPR1	DC	DC	DC	DC	DC	DC	DC	DC	
	10 = MPR2	DC	DC	DC	DC	DC	DC	DC	DC	
	11 = MPR3	DC	DC	DC	DC	MAC	MAC	MAC	MAC	

- Notes: 1. DC = "Don't Care"  
 2. MPR[4:3] 00 = Sub 1X refresh; MPR[4:3] 01 = 1X refresh; MPR[4:3] 10 = 2X refresh; MPR[4:3] 11 = Reserved

## MPR Reads

MPR reads are supported using BL8 and BC4 modes. Burst length on-the-fly is not supported for MPR reads. Data bus inversion (DBI) is not allowed during MPR READ operation; the device will ignore the Read DBI enable setting in MR5 [12] when in MPR mode. READ commands for BC4 are supported with a starting column address of A[2:0] = 000 or 100. After power-up, the content of MPR Page 0 has the default values, which are defined in Table 29. MPR page 0 can be rewritten via an MPR WRITE command. The de-

vice maintains the default values unless it is rewritten by the DRAM controller. If the DRAM controller does overwrite the default values (Page 0 only), the device will maintain the new values unless re-initialized or there is power loss.

Timing in MPR mode:

- Reads (back-to-back) from Page 0 may use  $t_{CCD\_S}$  or  $t_{CCD\_L}$  timing between READ commands
- Reads (back-to-back) from Pages 1, 2, or 3 may not use  $t_{CCD\_S}$  timing between READ commands;  $t_{CCD\_L}$  must be used for timing between READ commands

The following steps are required to use the MPR to read out the contents of a mode register (MPR Page  $x$ , MPR $y$ ).

1. The DLL must be locked if enabled.
2. Precharge all; wait until  $t_{RP}$  is satisfied.
3. MRS command to MR3[2] = 1 (Enable MPR data flow), MR3[12:11] = MPR read format, and MR3[1:0] MPR page.
  - a. MR3[12:11] MPR read format:
    1. 00 = Serial read format
    2. 01 = Parallel read format
    3. 10 = staggered read format
    4. 11 = RFU
  - b. MR3[1:0] MPR page:
    1. 00 = MPR Page 0
    2. 01 = MPR Page 1
    3. 10 = MPR Page 2
    4. 11 = MPR Page 3
4.  $t_{MRD}$  and  $t_{MOD}$  must be satisfied.
5. Redirect all subsequent READ commands to specific MPR $x$  location.
6. Issue RD or RDA command.
  - a. BA1 and BA0 indicate MPR $x$  location:
    1. 00 = MPR0
    2. 01 = MPR1
    3. 10 = MPR2
    4. 11 = MPR3
  - b. A12/BC = 0 or 1; BL8 or BC4 fixed-only, BC4 OTF not supported.
    1. If BL = 8 and MR0 A[1:0] = 01, A12/BC must be set to 1 during MPR READ commands.
  - c. A2 = burst-type dependant:
    1. BL8: A2 = 0 with burst order fixed at 0, 1, 2, 3, 4, 5, 6, 7
    2. BL8: A2 = 1 not allowed
    3. BC4: A2 = 0 with burst order fixed at 0, 1, 2, 3, T, T, T, T
    4. BC4: A2 = 1 with burst order fixed at 4, 5, 6, 7, T, T, T, T
  - d. A[1:0] = 00, data burst is fixed nibble start at 00.
  - e. Remaining address inputs, including A10, and BG1 and BG0 are "Don't Care."
7. After RL = AL + CL, DRAM bursts data from MPR $x$  location; MPR readout format determined by MR3[A12,11,1,0].
8. Steps 5 through 7 may be repeated to read additional MPR $x$  locations.
9. After the last MPR $x$  READ burst,  $t_{MPRR}$  must be satisfied prior to exiting.
10. Issue MRS command to exit MPR mode; MR3[2] = 0.
11. After the  $t_{MOD}$  sequence is completed, the DRAM is ready for normal operation from the core (such as ACT).

## MPR Readout Format

The MPR read data format can be set to three different settings: serial, parallel, and staggered.

## MPR Readout Serial Format

The serial format is required when enabling the MPR function to read out the contents of an MRx, temperature sensor status, and the command address parity error frame. However, data bus calibration locations (four 8-bit registers) can be programmed to read out any of the three formats. The DRAM is required to drive associated strobes with the read data similar to normal operation (such as using MRS preamble settings).

Serial format implies that the same pattern is returned on all DQ lanes, as shown the table below, which uses values programmed into the MPR via [7:0] as 0111 1111.

**Table 30: MPR Readout Serial Format**

Serial	UI0	UI1	UI2	UI3	UI4	UI5	UI6	UI7
<b>x4 Device</b>								
DQ0	0	1	1	1	1	1	1	1
DQ1	0	1	1	1	1	1	1	1
DQ2	0	1	1	1	1	1	1	1
DQ3	0	1	1	1	1	1	1	1
<b>x8 Device</b>								
DQ0	0	1	1	1	1	1	1	1
DQ1	0	1	1	1	1	1	1	1
DQ2	0	1	1	1	1	1	1	1
DQ3	0	1	1	1	1	1	1	1
DQ4	0	1	1	1	1	1	1	1
DQ5	0	1	1	1	1	1	1	1
DQ6	0	1	1	1	1	1	1	1
DQ7	0	1	1	1	1	1	1	1
<b>x16 Device</b>								
DQ0	0	1	1	1	1	1	1	1
DQ1	0	1	1	1	1	1	1	1
DQ2	0	1	1	1	1	1	1	1
DQ3	0	1	1	1	1	1	1	1
DQ4	0	1	1	1	1	1	1	1
DQ5	0	1	1	1	1	1	1	1
DQ6	0	1	1	1	1	1	1	1
DQ7	0	1	1	1	1	1	1	1
DQ8	0	1	1	1	1	1	1	1
DQ9	0	1	1	1	1	1	1	1
DQ10	0	1	1	1	1	1	1	1
DQ11	0	1	1	1	1	1	1	1

**Table 30: MPR Readout Serial Format (Continued)**

Serial	UI0	UI1	UI2	UI3	UI4	UI5	UI6	UI7
DQ12	0	1	1	1	1	1	1	1
DQ13	0	1	1	1	1	1	1	1
DQ14	0	1	1	1	1	1	1	1
DQ15	0	1	1	1	1	1	1	1

### MPR Readout Parallel Format

Parallel format implies that the MPR data is returned in the first data UI and then repeated in the remaining UIs of the burst, as shown in the table below. Data pattern location 0 is the only location used for the parallel format. RD/RDA from data pattern locations 1, 2, and 3 are not allowed with parallel data return mode. In this example, the pattern programmed in the data pattern location 0 is 0111 1111. The x4 configuration only outputs the first four bits (0111 in this example). For the x16 configuration, the same pattern is repeated on both the upper and lower bytes.

**Table 31: MPR Readout – Parallel Format**

Parallel	UI0	UI1	UI2	UI3	UI4	UI5	UI6	UI7
<b>x4 Device</b>								
DQ0	0	0	0	0	0	0	0	0
DQ1	1	1	1	1	1	1	1	1
DQ2	1	1	1	1	1	1	1	1
DQ3	1	1	1	1	1	1	1	1
<b>x8 Device</b>								
DQ0	0	0	0	0	0	0	0	0
DQ1	1	1	1	1	1	1	1	1
DQ2	1	1	1	1	1	1	1	1
DQ3	1	1	1	1	1	1	1	1
DQ4	1	1	1	1	1	1	1	1
DQ5	1	1	1	1	1	1	1	1
DQ6	1	1	1	1	1	1	1	1
DQ7	1	1	1	1	1	1	1	1
<b>x16 Device</b>								
DQ0	0	0	0	0	0	0	0	0
DQ1	1	1	1	1	1	1	1	1
DQ2	1	1	1	1	1	1	1	1
DQ3	1	1	1	1	1	1	1	1
DQ4	1	1	1	1	1	1	1	1
DQ5	1	1	1	1	1	1	1	1
DQ6	1	1	1	1	1	1	1	1
DQ7	1	1	1	1	1	1	1	1

**Table 31: MPR Readout – Parallel Format (Continued)**

Parallel	UI0	UI1	UI2	UI3	UI4	UI5	UI6	UI7
DQ8	0	0	0	0	0	0	0	0
DQ9	1	1	1	1	1	1	1	1
DQ10	1	1	1	1	1	1	1	1
DQ11	1	1	1	1	1	1	1	1
DQ12	1	1	1	1	1	1	1	1
DQ13	1	1	1	1	1	1	1	1
DQ14	1	1	1	1	1	1	1	1
DQ15	1	1	1	1	1	1	1	1

### MPR Readout Staggered Format

Staggered format of data return is defined as the staggering of the MPR data across the lanes. In this mode, an RD/RDA command is issued to a specific data pattern location and then the data is returned on the DQ from each of the different data pattern locations. For the x4 configuration, an RD/RDA to data pattern location 0 will result in data from location 0 being driven on DQ0, data from location 1 being driven on DQ1, data from location 2 being driven on DQ2, and so on, as shown below. Similarly, an RD/RDA command to data pattern location 1 will result in data from location 1 being driven on DQ0, data from location 2 being driven on DQ1, data from location 3 being driven on DQ2, and so on. Examples of different starting locations are also shown.

**Table 32: MPR Readout Staggered Format, x4**

x4 READ MPR0 Command		x4 READ MPR1 Command		x4 READ MPR2 Command		x4 READ MPR3 Command	
Stagger	UI[7:0]	Stagger	UI[7:0]	Stagger	UI[7:0]	Stagger	UI[7:0]
DQ0	MPR0	DQ0	MPR1	DQ0	MPR2	DQ0	MPR3
DQ1	MPR1	DQ1	MPR2	DQ1	MPR3	DQ1	MPR0
DQ2	MPR2	DQ2	MPR3	DQ2	MPR0	DQ2	MPR1
DQ3	MPR3	DQ3	MPR0	DQ3	MPR1	DQ3	MPR2

It is expected that the DRAM can respond to back-to-back RD/RDA commands to the MPR for all DDR4 frequencies so that a sequence (such as the one that follows) can be created on the data bus with no bubbles or clocks between read data. In this case, the system memory controller issues a sequence of RD(MPR0), RD(MPR1), RD(MPR2), RD(MPR3), RD(MPR0), RD(MPR1), RD(MPR2), and RD(MPR3).

**Table 33: MPR Readout Staggered Format, x4 – Consecutive READs**

Stagger	UI[7:0]	UI[15:8]	UI[23:16]	UI[31:24]	UI[39:32]	UI[47:40]	UI[55:48]	UI[63:56]
DQ0	MPR0	MPR1	MPR2	MPR3	MPR0	MPR1	MPR2	MPR3
DQ1	MPR1	MPR2	MPR3	MPR0	MPR1	MPR2	MPR3	MPR0
DQ2	MPR2	MPR3	MPR0	MPR1	MPR2	MPR3	MPR0	MPR1
DQ3	MPR3	MPR0	MPR1	MPR2	MPR3	MPR0	MPR1	MPR2

For the x8 configuration, the same pattern is repeated on the lower nibble as on the upper nibble. READs to other MPR data pattern locations follow the same format as the x4 case. A read example to MPR0 for x8 and x16 configurations is shown below.

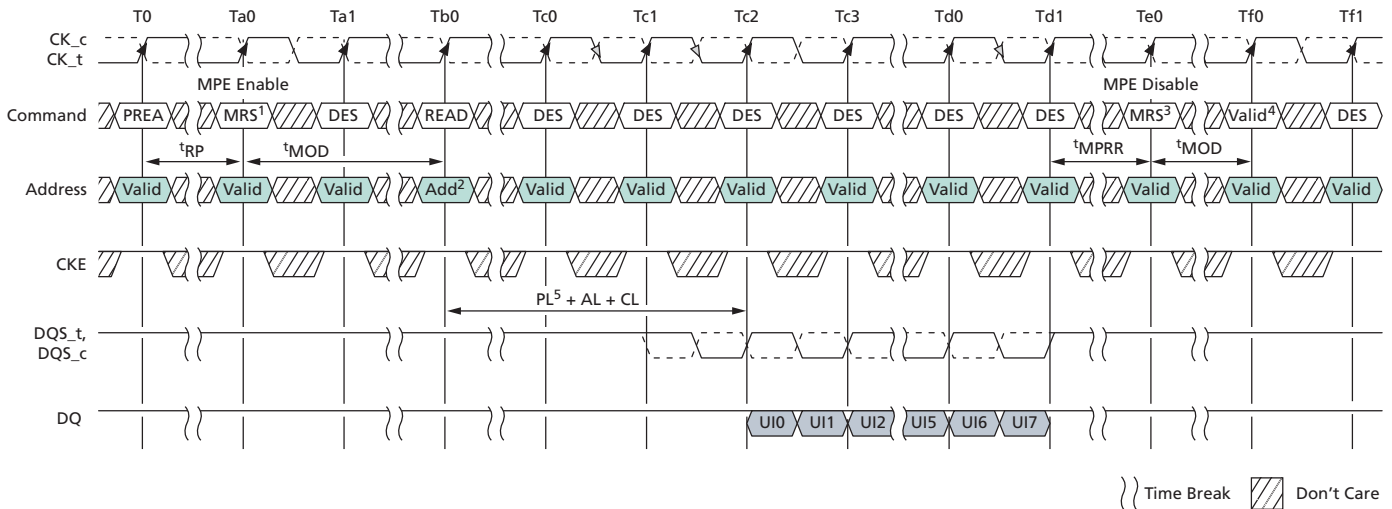
**Table 34: MPR Readout Staggered Format, x8 and x16**

x8 READ MPR0 Command		x16 READ MPR0 Command		x16 READ MPR0 Command	
Stagger	UI[7:0]	Stagger	UI[7:0]	Stagger	UI[7:0]
DQ0	MPR0	DQ0	MPR0	DQ8	MPR0
DQ1	MPR1	DQ1	MPR1	DQ9	MPR1
DQ2	MPR2	DQ2	MPR2	DQ10	MPR2
DQ3	MPR3	DQ3	MPR3	DQ11	MPR3
DQ4	MPR0	DQ4	MPR0	DQ12	MPR0
DQ5	MPR1	DQ5	MPR1	DQ13	MPR1
DQ6	MPR2	DQ6	MPR2	DQ14	MPR2
DQ7	MPR3	DQ7	MPR3	DQ15	MPR3

**MPR READ Waveforms**

The following waveforms show MPR read accesses.

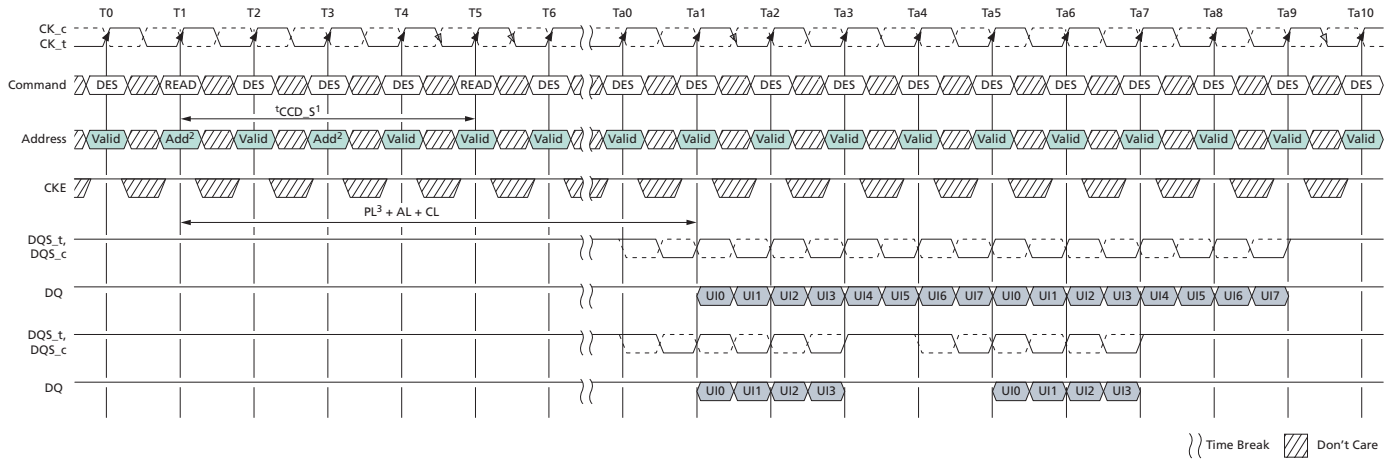
**Figure 29: MPR READ Timing**



- Notes:
- $t_{CCD\_S} = 4t_{CK}$ , Read Preamble =  $1t_{CK}$ .
  - Address setting:  
 $A[1:0] = 00b$  (data burst order is fixed starting at nibble, always 00b here)  
 $A2 = 0b$  (for BL = 8, burst order is fixed at 0, 1, 2, 3, 4, 5, 6, 7)  
 BA1 and BA0 indicate the MPR location  
 A10 and other address pins are "Don't Care," including BG1 and BG0. A12 is "Don't Care" when MR0 A[1:0] = 00 or 10 and must be 1b when MR0 A[1:0] = 01
  - Multipurpose registers read/write disable (MR3 A2 = 0).
  - Continue with regular DRAM command.

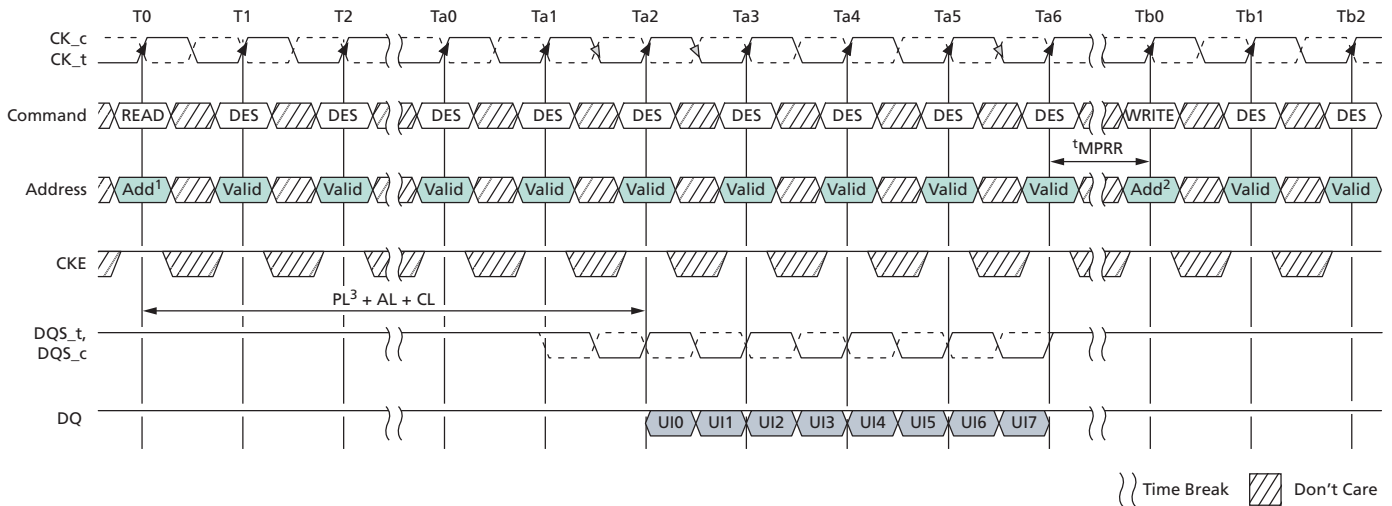
- Parity latency (PL) is added to data output delay when CA parity latency mode is enabled.

**Figure 30: MPR Back-to-Back READ Timing**



- Notes:
- $t^{\text{CCD\_S}} = 4t^{\text{CK}}$ , Read Preamble =  $1t^{\text{CK}}$ .
  - Address setting:  
 $A[1:0] = 00b$  (data burst order is fixed starting at nibble, always 00b here)  
 $A2 = 0b$  (for BL = 8, burst order is fixed at 0, 1, 2, 3, 4, 5, 6, 7; for BC = 4, burst order is fixed at 0, 1, 2, 3, T, T, T, T)  
 BA1 and BA0 indicate the MPR location  
 A10 and other address pins are "Don't Care," including BG1 and BG0. A12 is "Don't Care" when MR0 A[1:0] = 00 or 10 and must be 1b when MR0 A[1:0] = 01
  - Parity latency (PL) is added to data output delay when CA parity latency mode is enabled.

**Figure 31: MPR READ-to-WRITE Timing**



- Notes:
1. Address setting:
    - A[1:0] = 00b (data burst order is fixed starting at nibble, always 00b here)
    - A2 = 0b (for BL = 8, burst order is fixed at 0, 1, 2, 3, 4, 5, 6, 7)
    - BA1 and BA0 indicate the MPR location
    - A10 and other address pins are "Don't Care," including BG1 and BG0. A12 is "Don't Care" when MR0 A[1:0] = 00 and must be 1b when MR0 A[1:0] = 01
  2. Address setting:
    - BA1 and BA0 indicate the MPR location
    - A[7:0] = data for MPR
    - BA1 and BA0 indicate the MPR location
    - A10 and other address pins are "Don't Care"
  3. Parity latency (PL) is added to data output delay when CA parity latency mode is enabled.

## MPR Writes

MPR access mode allows 8-bit writes to the MPR location using the address bus A[7:0]. Data bus inversion (DBI) is not allowed during MPR WRITE operation. The DRAM will maintain the new written values unless re-initialized or there is power loss.

The following steps are required to use the MPR to write to mode register MPR Page 0, MPRy).

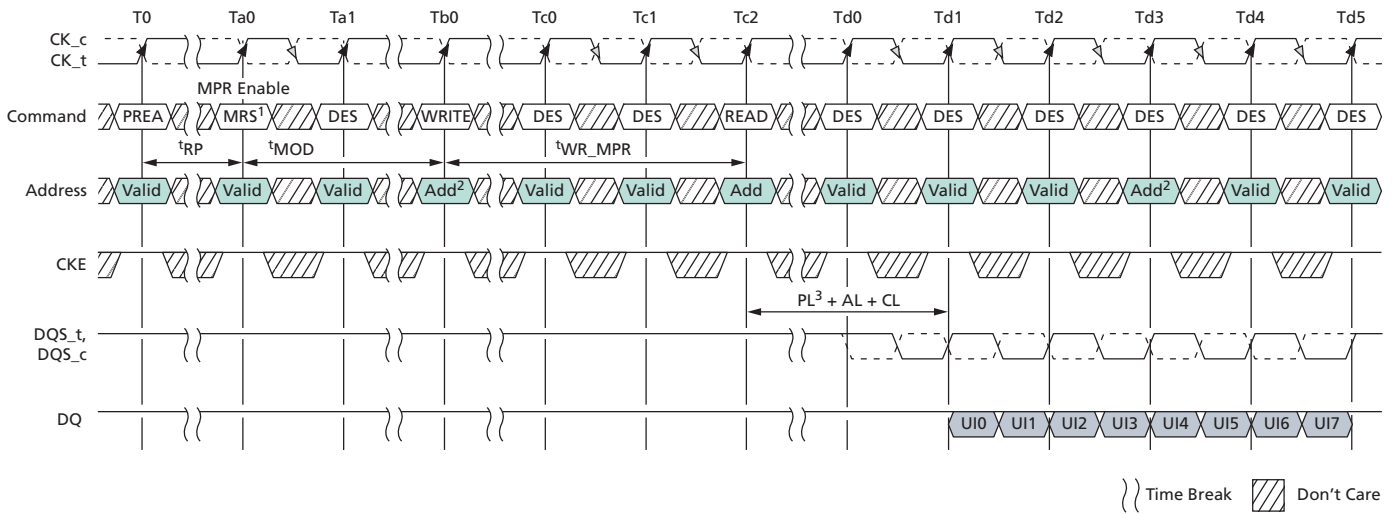
1. The DLL must be locked if enabled.
2. Precharge all; wait until  $t^1RP$  is satisfied.
3. MRS command to MR3[2] = 1 (enable MPR data flow) and MR3[1:0] = 00 (MPR Page 0); 01, 10, and 11 are not allowed.
4.  $t^1MRD$  and  $t^1MOD$  must be satisfied.
5. Redirect all subsequent WRITE commands to specific MPRx location.
6. Issue WR or WRA command:
  - a. BA1 and BA0 indicate MPRx location
    1. 00 = MPR0
    2. 01 = MPR1
    3. 10 = MPR2
    4. 11 = MPR3

- b. A[7:0] = data for MPR Page 0, mapped A[7:0] to UI[7:0].
- c. Remaining address inputs, including A10, and BG1 and BG0 are "Don't Care."
- 7.  $t_{WR\_MPR}$  must be satisfied to complete MPR WRITE.
- 8. Steps 5 through 7 may be repeated to write additional MPR<sub>x</sub> locations.
- 9. After the last MPR<sub>x</sub> WRITE,  $t_{MPRR}$  must be satisfied prior to exiting.
- 10. Issue MRS command to exit MPR mode; MR3[2] = 0.
- 11. When the  $t_{MOD}$  sequence is completed, the DRAM is ready for normal operation from the core (such as ACT).

**MPR WRITE Waveforms**

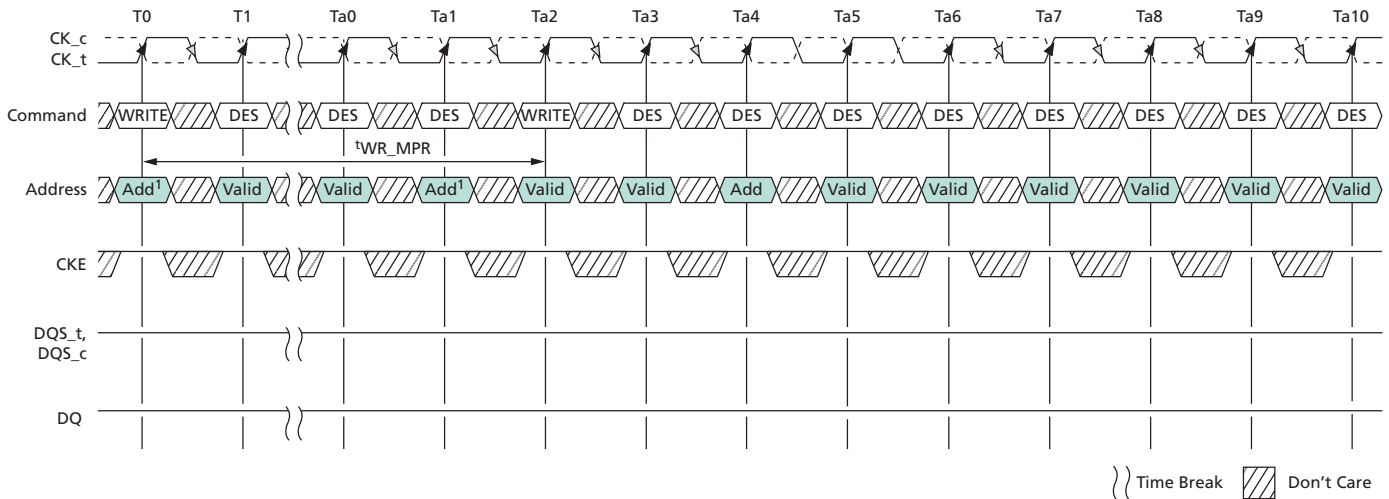
The following waveforms show MPR write accesses.

**Figure 32: MPR WRITE and WRITE-to-READ Timing**



- Notes:
1. Multipurpose registers read/write enable (MR3 A2 = 1).
  2. Address setting:  
BA1 and BA0 indicate the MPR location  
A10 and other address pins are "Don't Care"
  3. Parity latency (PL) is added to data output delay when CA parity latency mode is enabled.

**Figure 33: MPR Back-to-Back WRITE Timing**

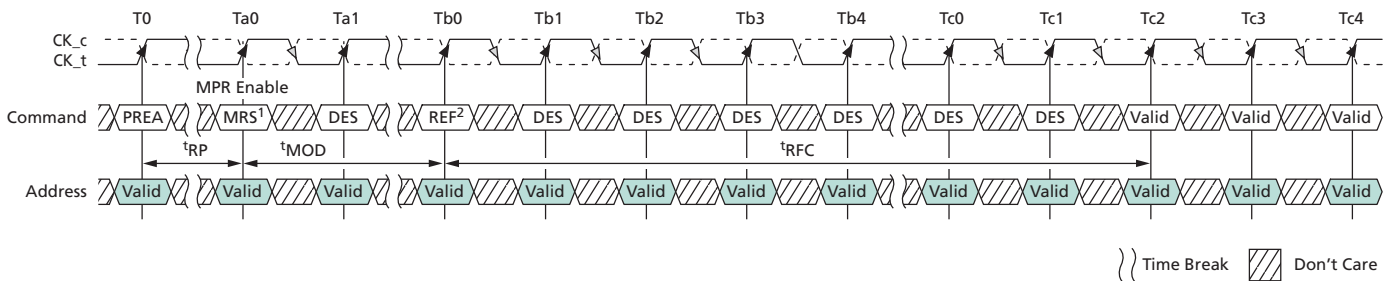


Note: 1. Address setting:  
 BA1 and BA0 indicate the MPR location  
 A[7:0] = data for MPR  
 A10 and other address pins are "Don't Care"

**MPR REFRESH Waveforms**

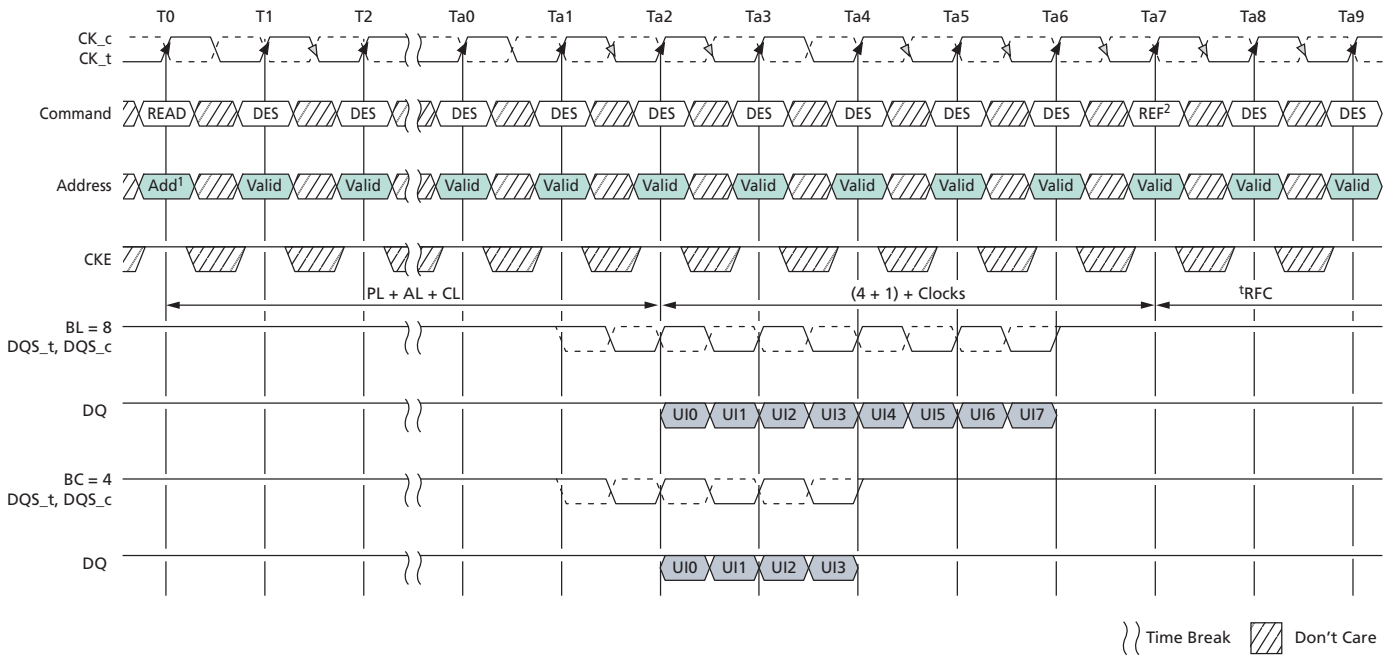
The following waveforms show MPR accesses interaction with refreshes.

**Figure 34: REFRESH Timing**



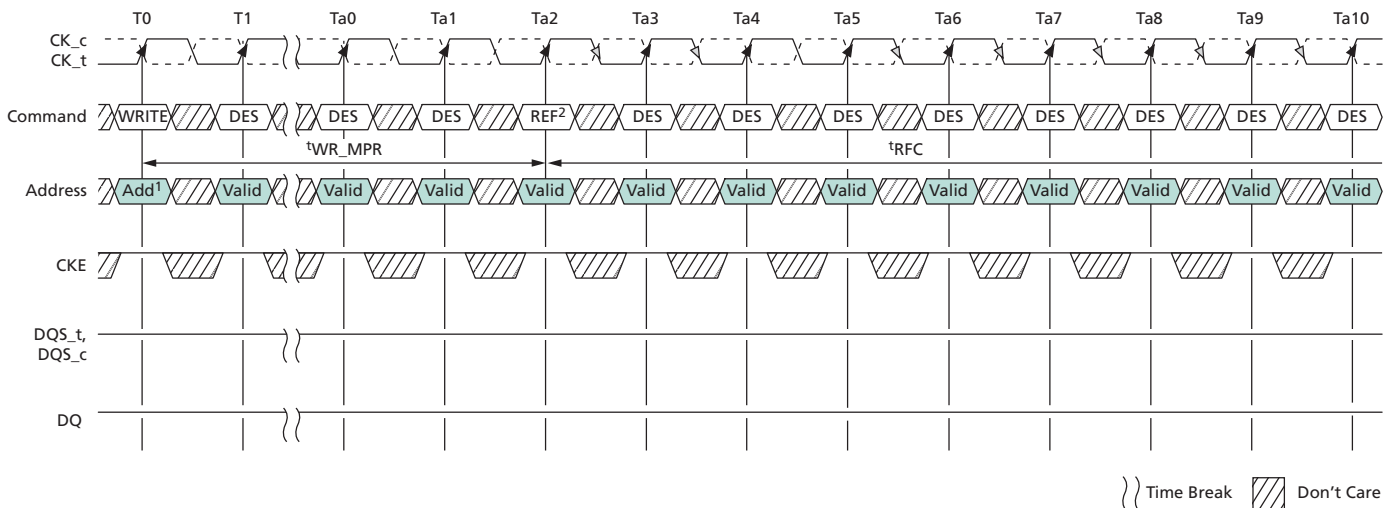
Notes: 1. Multipurpose registers read/write enable (MR3 A2 = 1). Redirect all subsequent read and writes to MPR locations.  
 2. 1x refresh is only allowed when MPR mode is enabled.

**Figure 35: READ-to-REFRESH Timing**



- Notes:
- Address setting:  
 A[1:0] = 00b (data burst order is fixed starting at nibble, always 00b here)  
 A2 = 0b (for BL = 8, burst order is fixed at 0, 1, 2, 3, 4, 5, 6, 7)  
 BA1 and BA0 indicate the MPR location  
 A10 and other address pins are "Don't Care," including BG1 and BG0. A12 is "Don't Care" when MR0 A[1:0] = 00 or 10, and must be 1b when MR0 A[1:0] = 01
  - 1x refresh is only allowed when MPR mode is enabled.

**Figure 36: WRITE-to-REFRESH Timing**



- Notes:
- Address setting:  
 BA1 and BA0 indicate the MPR location

- A[7:0] = data for MPR
- A10 and other address pins are "Don't Care"
- 2. 1x refresh is only allowed when MPR mode is enabled.

## Gear-Down Mode

The DDR4 SDRAM defaults in 1/2 rate (1N) clock mode and uses a low-frequency MRS command (the MRS command has relaxed setup and hold) followed by a sync pulse (first CS pulse after MRS setting) to align the proper clock edge for operating the control lines CS<sub>n</sub>, CKE, and ODT when in 1/4 rate (2N) mode. Gear-down mode is only supported at DDR4-2666 and faster. For operation in 1/2 rate mode, neither an MRS command or a sync pulse is required. Gear-down mode may only be entered during initialization or self refresh exit and may only be exited during self refresh exit. The general sequence for operation in 1/4 rate during initialization is as follows:

1. The device defaults to a 1N mode internal clock at power-up/reset.
2. Assertion of reset.
3. Assertion of CKE enables the DRAM.
4. MRS is accessed with a low-frequency  $N \times t_{CK}$  gear-down MRS command. ( $N t_{CK}$  static MRS command is qualified by 1N CS<sub>n</sub>.)
5. The memory controller will send a 1N sync pulse with a low-frequency  $N \times t_{CK}$  NOP command.  $t_{SYNC\_GEAR}$  is an even number of clocks. The sync pulse is on an even edge clock boundary from the MRS command.
6. Initialization sequence, including the expiration of  $t_{DLLK}$  and  $t_{ZQinit}$ , starts in 2N mode after  $t_{CMD\_GEAR}$  from 1N sync pulse.

The device resets to 1N gear-down mode after entering self refresh. The general sequence for operation in gear-down after self refresh exit is as follows:

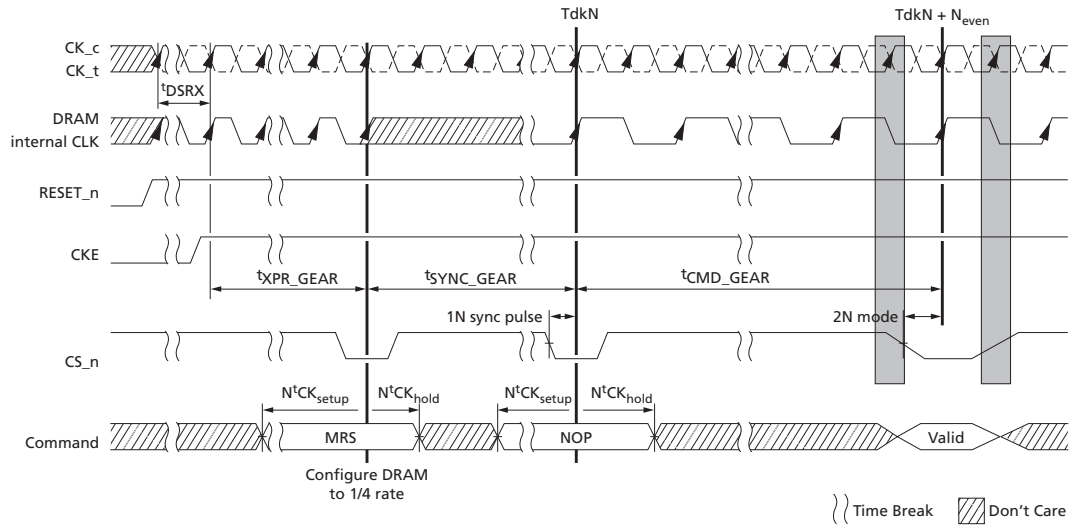
1. MRS is set to 1, via MR3[3], with a low-frequency  $N \times t_{CK}$  gear-down MRS command.
  - a. The  $N t_{CK}$  static MRS command is qualified by 1N CS<sub>n</sub>, which meets  $t_{XS}$  or  $t_{XS\_ABORT}$ .
  - b. Only a REFRESH command may be issued to the DRAM before the  $N t_{CK}$  static MRS command.
2. The DRAM controller sends a 1N sync pulse with a low-frequency  $N \times t_{CK}$  NOP command.
  - a.  $t_{SYNC\_GEAR}$  is an even number of clocks.
  - b. The sync pulse is on even edge clock boundary from the MRS command.
3. A valid command not requiring locked DLL is available in 2N mode after  $t_{CMD\_GEAR}$  from the 1N sync pulse.
  - a. A valid command requiring locked DLL is available in 2N mode after  $t_{XSDLL}$  or  $t_{DLLK}$  from the 1N sync pulse.
4. If operation is in 1N mode after self refresh exit,  $N \times t_{CK}$  MRS command or sync pulse is not required during self refresh exit. The minimum exit delay to the first valid command is  $t_{XS}$ , or  $t_{XS\_ABORT}$ .

The DRAM may be changed from 2N to 1N by entering self refresh mode, which will reset to 1N mode. Changing from 2N to by any other means can result in loss of data and make operation of the DRAM uncertain.

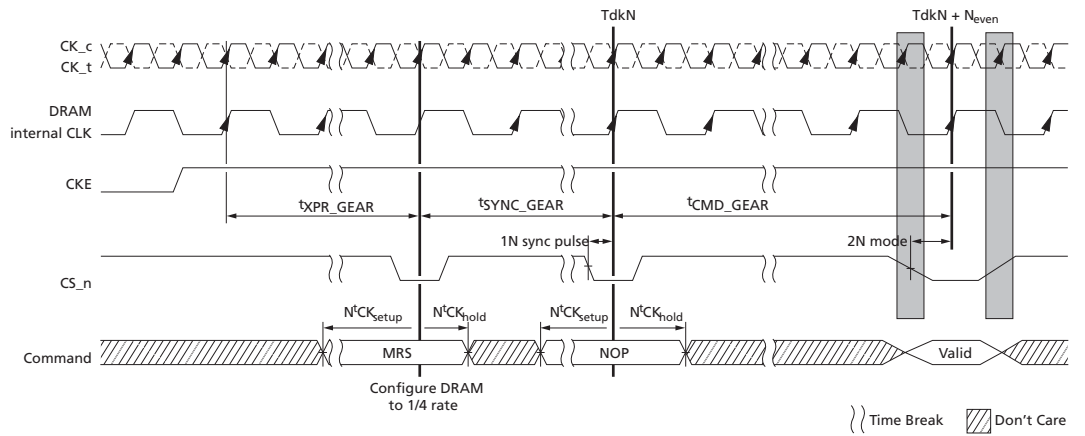
When operating in 2N gear-down mode, the following MR settings apply:

- CAS latency (MR0[6:4,2]): Even number of clocks
- Write recovery and read to precharge (MR0[11:9]): Even number of clocks
- Additive latency (MR1[4:3]): CL - 2
- CAS WRITE latency (MR2 A[5:3]): Even number of clocks
- CS to command/address latency mode (MR4[8:6]): Even number of clocks
- CA parity latency mode (MR5[2:0]): Even number of clocks

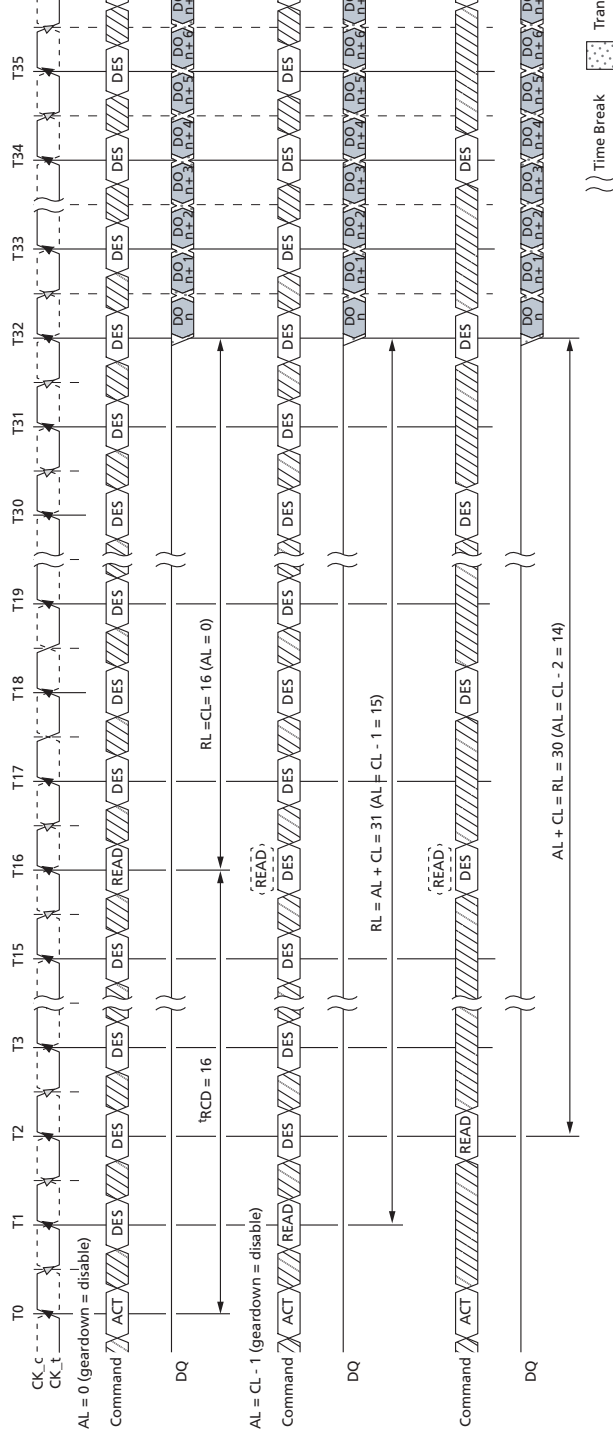
**Figure 37: Clock Mode Change from 1/2 Rate to 1/4 Rate (Initialization)**



**Figure 38: Clock Mode Change After Exiting Self Refresh**



**Figure 39: Comparison Between Gear-Down Disable and Gear-Down Enable**



## Maximum Power-Saving Mode

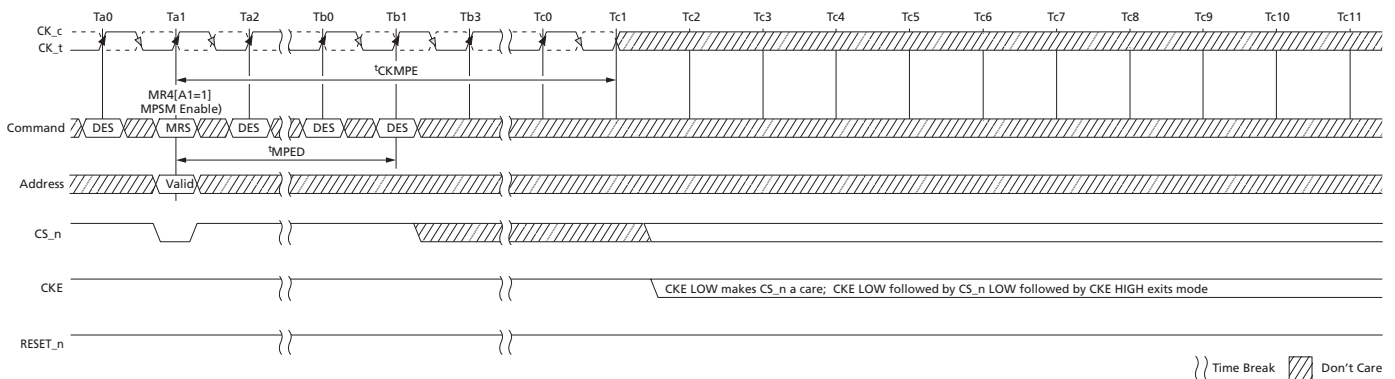
Maximum power-saving mode provides the lowest power mode where data retention is not required. When the device is in the maximum power-saving mode, it does not maintain data retention or respond to any external command, except the MAXIMUM POWER SAVING MODE EXIT command and during the assertion of RESET\_n signal LOW. This mode is more like a “hibernate mode” than a typical power-saving mode. The intent is to be able to park the DRAM at a very low-power state; the device can be switched to an active state via the per-DRAM addressability (PDA) mode.

### Maximum Power-Saving Mode Entry

Maximum power-saving mode is entered through an MRS command. For devices with shared control/address signals, a single DRAM device can be entered into the maximum power-saving mode using the per-DRAM addressability MRS command. Large CS\_n hold time to CKE upon the mode exit could cause DRAM malfunction; as a result, CA parity, CAL, and gear-down modes must be disabled prior to the maximum power-saving mode entry MRS command.

The MRS command may use both address and DQ information, as defined in the Per-DRAM Addressability section. As illustrated in the figure below, after <sup>t</sup>MPED from the mode entry MRS command, the DRAM is not responsive to any input signals except CKE, CS\_n, and RESET\_n. All other inputs are disabled (external input signals may become High-Z). The system will provide a valid clock until <sup>t</sup>CKMPE expires, at which time clock inputs (CK) should be disabled (external clock signals may become High-Z).

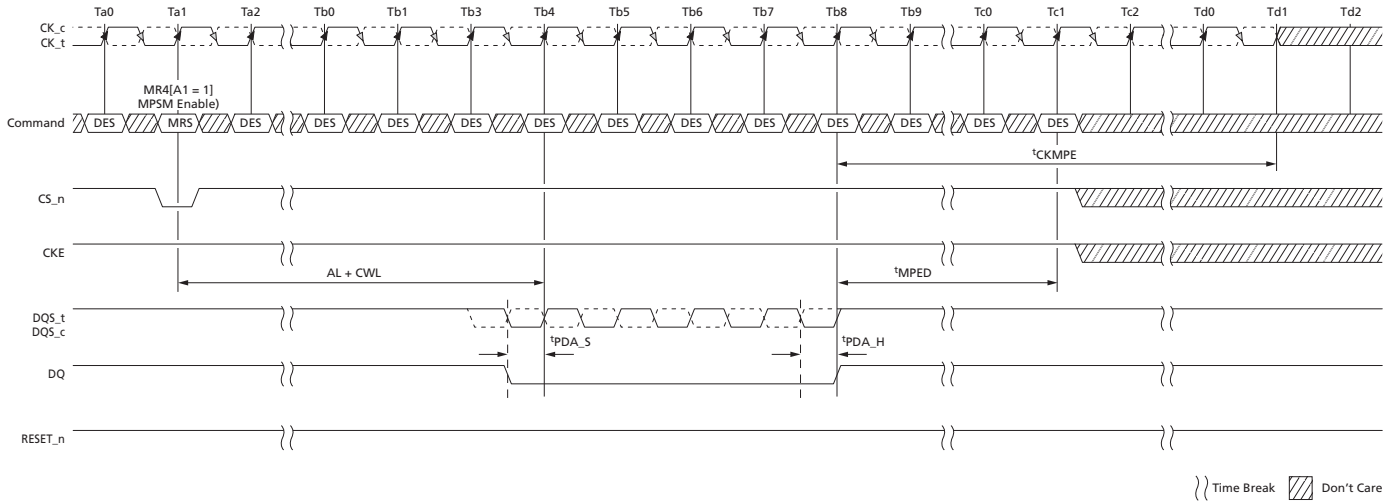
**Figure 40: Maximum Power-Saving Mode Entry**



### Maximum Power-Saving Mode Entry in PDA

The sequence and timing required for the maximum power-saving mode with the per-DRAM addressability enabled is illustrated in the figure below.

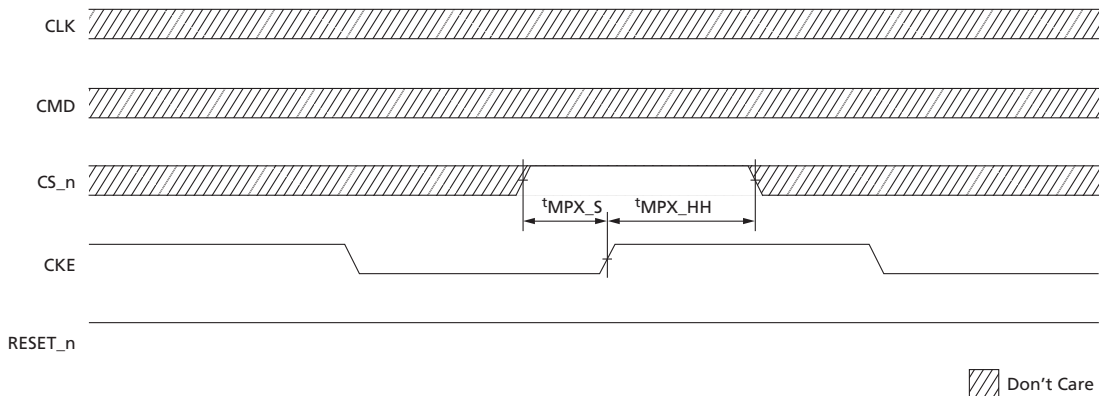
**Figure 41: Maximum Power-Saving Mode Entry with PDA**



### CKE Transition During Maximum Power-Saving Mode

The following figure shows how to maintain maximum power-saving mode even though the CKE input may toggle. To prevent the device from exiting the mode, CS\_n should be HIGH at the CKE LOW-to-HIGH edge, with appropriate setup ( $t_{MPX\_S}$ ) and hold ( $t_{MPX\_H}$ ) timings.

**Figure 42: Maintaining Maximum Power-Saving Mode with CKE Transition**

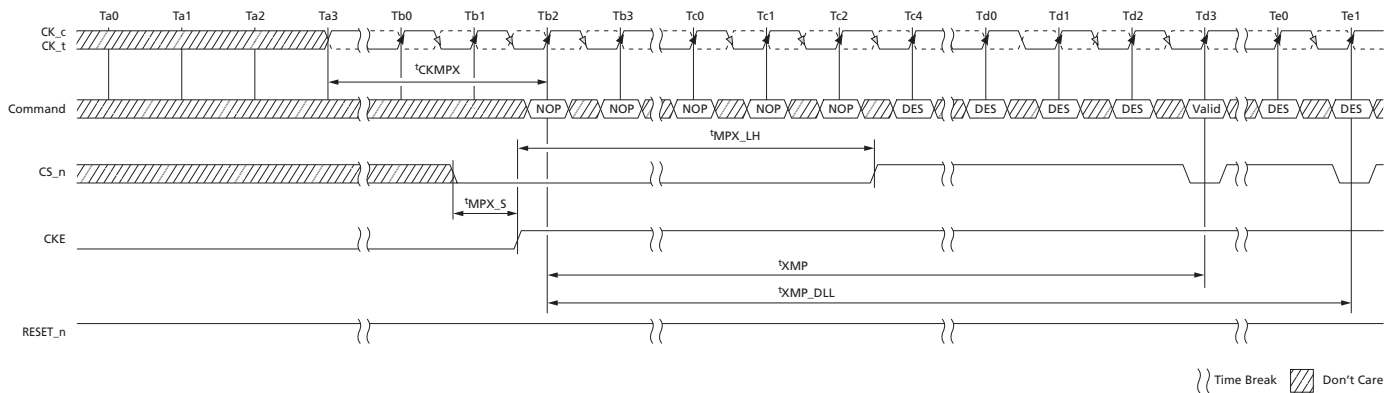


### Maximum Power-Saving Mode Exit

To exit the maximum power-saving mode, CS\_n should be LOW at the CKE LOW-to-HIGH transition, with appropriate setup ( $t_{MPX\_S}$ ) and hold ( $t_{MPX\_LH}$ ) timings, as

shown in the figure below. Because the clock receivers (CK\_t, CK\_c) are disabled during this mode, CS\_n = LOW is captured by the rising edge of the CKE signal. If the CS\_n signal level is detected LOW, the DRAM clears the maximum power-saving mode MRS bit and begins the exit procedure from this mode. The external clock must be restarted and be stable by  $t^{CKMPX}$  before the device can exit the maximum power-saving mode. During the exit time ( $t^{XMP}$ ), only NOP and DES commands are allowed: NOP during  $t^{MPX\_LH}$  and DES the remainder of  $t^{XMP}$ . After  $t^{XMP}$  expires, valid commands not requiring a locked DLL are allowed; after  $t^{XMP\_DLL}$  expires, valid commands requiring a locked DLL are allowed.

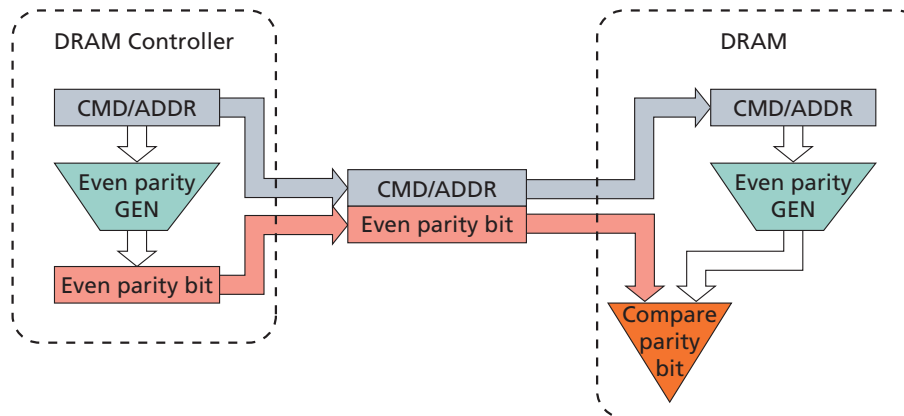
**Figure 43: Maximum Power-Saving Mode Exit**



## Command/Address Parity

Command/address (CA) parity takes the CA parity signal (PAR) input carrying the parity bit for the generated address and commands signals and matches it to the internally generated parity from the captured address and commands signals.

**Figure 44: Command/Address Parity Operation**



CA parity is disabled or enabled via an MRS command. If CA parity is enabled by programming a non-zero value to CA parity latency in the MR, the DRAM will ensure that there is no parity error before executing commands. There is an additional delay required for executing the commands versus when parity is disabled. The delay is programmed in the MR when CA parity is enabled (parity latency) and applied to all commands which are registered by CS<sub>n</sub> (rising edge of CK<sub>t</sub> and falling CS<sub>n</sub>). The command is held for the time of the parity latency (PL) before it is executed inside the device. The command captured by the input clock has an internal delay before executing and is determined with PL. When CA parity is enabled, only DES are allowed between valid commands. PAR will go active when the DRAM detects a CA parity error.

CA parity covers ACT<sub>n</sub>, RAS<sub>n</sub>/A16, CAS<sub>n</sub>/A15, WE<sub>n</sub>/A14, the address bus including bank address and bank group bits, and C[2:0] on 3DS devices; the control signals CKE, ODT, and CS<sub>n</sub> are not covered. For example, for a 4Gb x4 monolithic device, parity is computed across BG[1:0], BA[1:0], A16/RAS<sub>n</sub>, A15/CAS<sub>n</sub>, A14/WE<sub>n</sub>, A[13:0], and ACT<sub>n</sub>. The DRAM treats any unused address pins internally as zeros; for example, if a common die has stacked pins but the device is used in a monolithic application, then the address pins used for stacking and not connected are treated internally as zeros.

The convention for parity is even parity; for example, valid parity is defined as an even number of ones across the inputs used for parity computation combined with the parity signal. In other words, the parity bit is chosen so that the total number of ones in the transmitted signal, including the parity bit, is even.

If a DRAM device detects a CA parity error in any command qualified by CS<sub>n</sub>, it will perform the following steps:

1. Ignore the erroneous command. Commands in the MAX N<sub>n</sub>CK window (PAR\_UNKNOWN) prior to the erroneous command are not guaranteed to be executed. When a READ command in this N<sub>n</sub>CK window is not executed, the device does not activate DQS outputs.

2. Log the error by storing the erroneous command and address bits in the MPR error log.
  3. Set the parity error status bit in the mode register to 1. The parity error status bit must be set before the ALERT\_n signal is released by the DRAM (that is,  $t^{\text{PAR\_ALERT\_ON}} + t^{\text{PAR\_ALERT\_PW}}(\text{MIN})$ ).
  4. Assert the ALERT\_n signal to the host (ALERT\_n is active LOW) within  $t^{\text{PAR\_ALERT\_ON}}$  time.
  5. Wait for all in-progress commands to complete. These commands were received  $t^{\text{PAR\_UNKOWN}}$  before the erroneous command.
  6. Wait for  $t^{\text{RAS}}(\text{MIN})$  before closing all the open pages. The DRAM is not executing any commands during the window defined by  $(t^{\text{PAR\_ALERT\_ON}} + t^{\text{PAR\_ALERT\_PW}})$ .
  7. After  $t^{\text{PAR\_ALERT\_PW}}(\text{MIN})$  has been satisfied, the device may de-assert ALERT\_n.
    - a. When the device is returned to a known precharged state, ALERT\_n is allowed to be de-asserted.
  8. After  $(t^{\text{PAR\_ALERT\_PW}}(\text{MAX}))$  the DRAM is ready to accept commands for normal operation. Parity latency will be in effect; however, parity checking will not resume until the memory controller has cleared the parity error status bit by writing a zero. The DRAM will execute any erroneous commands until the bit is cleared; unless persistent mode is enabled.
- The DRAM should have only DES commands issued around ALERT\_n going HIGH such that at least 3 clocks prior and 1 clock plus 3ns after the release of ALERT\_n.
  - It is possible that the device might have ignored a REFRESH command during  $t^{\text{PAR\_ALERT\_PW}}$  or the REFRESH command is the first erroneous frame, so it is recommended that extra REFRESH cycles be issued, as needed.
  - The parity error status bit may be read anytime after  $t^{\text{PAR\_ALERT\_ON}} + t^{\text{PAR\_ALERT\_PW}}$  to determine which DRAM had the error. The device maintains the error log for the first erroneous command until the parity error status bit is reset to a zero or a second CA parity occurs prior to resetting.

The mode register for the CA parity error is defined as follows: CA parity latency bits are write only, the parity error status bit is read/write, and error logs are read-only bits. The DRAM controller can only program the parity error status bit to zero. If the DRAM controller illegally attempts to write a 1 to the parity error status bit, the DRAM can not be certain that parity will be checked; the DRAM may opt to block the DRAM controller from writing a 1 to the parity error status bit.

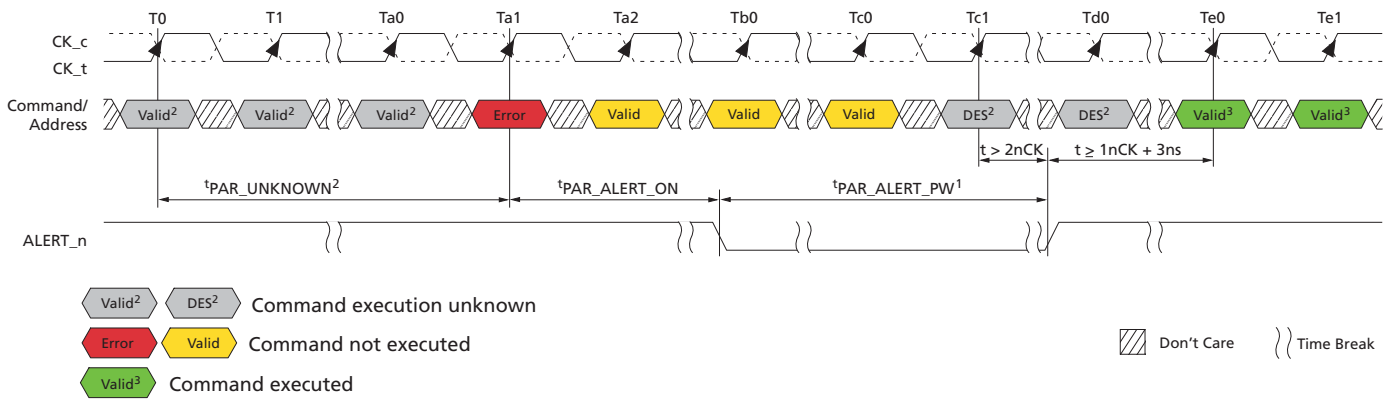
The device supports persistent parity error mode. This mode is enabled by setting MR5[9] = 1; when enabled, CA parity resumes checking after the ALERT\_n is de-asserted, even if the parity error status bit remains a 1. If multiple errors occur before the error status bit is cleared the error log in MPR Page 1 should be treated as "Don't Care." In persistent parity error mode the ALERT\_n pulse will be asserted and de-asserted by the DRAM as defined with the MIN and MAX value  $t^{\text{PAR\_ALERT\_PW}}$ . The DRAM controller must issue DESELECT commands once it detects the ALERT\_n signal, this response time is defined as  $t^{\text{PAR\_ALERT\_RSP}}$ . The following figures capture the flow of events on the CA bus and the ALERT\_n signal.

**Table 35: Mode Register Setting for CA Parity**

CA Parity Latency MR5[2:0] <sup>1</sup>	Applicable Speed Bin	Parity Error Status	Parity Persistent Mode	Erroneous CA Frame
000 = Disabled	N/A	MR5 [4] 0 = Clear MR5 [4] 1 = Error	MR5 [9] 0 = Disabled MR5 [9] 1 = Enabled	C[2:0], ACT_n, BG1, BG0, BA[1:0], PAR, A17, A16/RAS_n, A15/ CAS_n, A14/WE_n, A[13:0]
001 = 4 clocks	1600, 1866, 2133			
010 = 5 clocks	2400			
011 = 6 clocks	2666			
100 = 8 clocks	2933, 3200			
101 = Reserved	RFU			
110 = Reserved	RFU			
111 = Reserved	RFU			

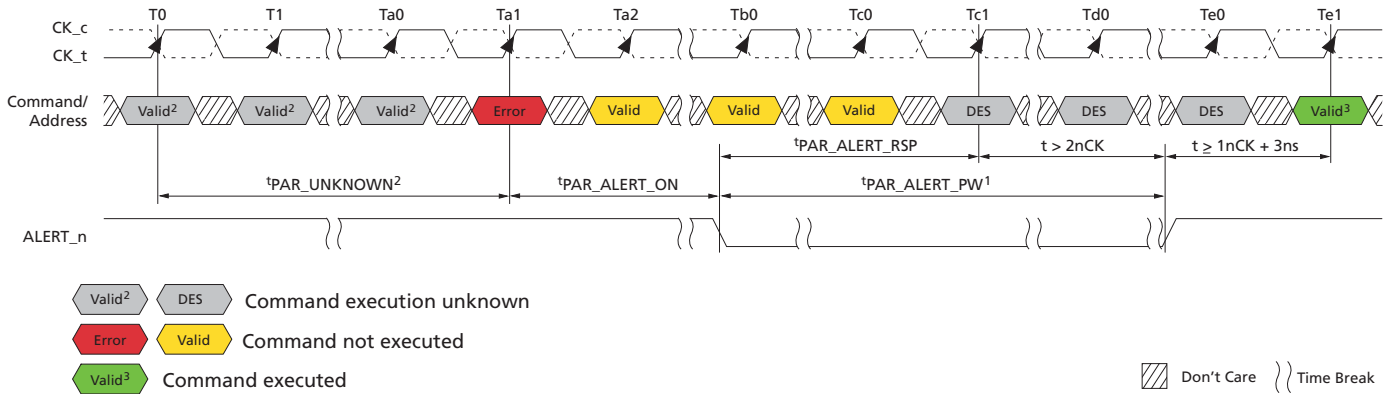
- Notes:
- Parity latency is applied to all commands.
  - Parity latency can be changed only from a CA parity disabled state; for example, a direct change from PL = 3 to PL = 4 is not allowed. The correct sequence is PL = 3 to disabled to PL = 4.
  - Parity latency is applied to WRITE and READ latency. WRITE latency = AL + CWL + PL. READ latency = AL + CL + PL.

**Figure 45: Command/Address Parity During Normal Operation**



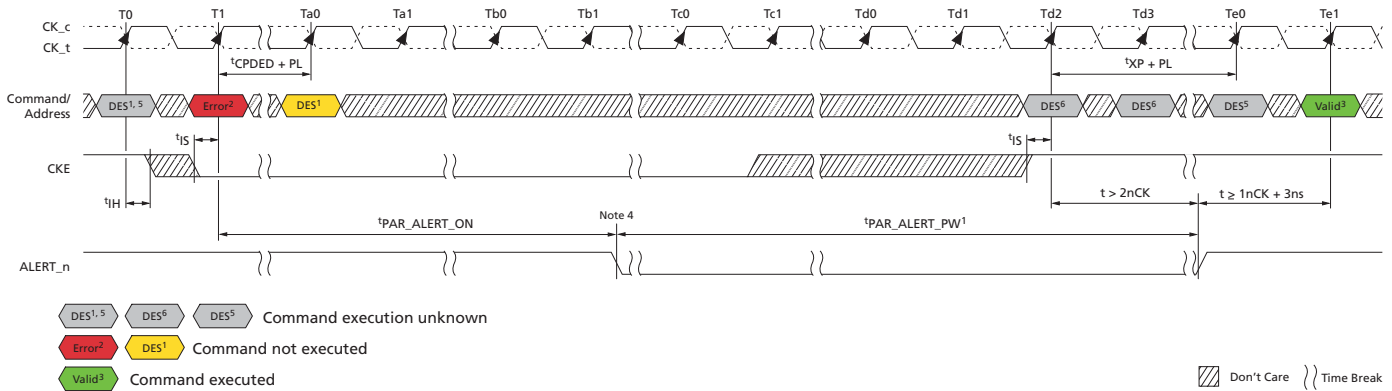
- Notes:
- DRAM is emptying queues. Precharge all and parity checking are off until parity error status bit is cleared.
  - Command execution is unknown; the corresponding DRAM internal state change may or may not occur. The DRAM controller should consider both cases and make sure that the command sequence meets the specifications.
  - Normal operation with parity latency (CA parity persistent error mode disabled). Parity checking is off until parity error status bit is cleared.

Figure 46: Persistent CA Parity Error Checking Operation



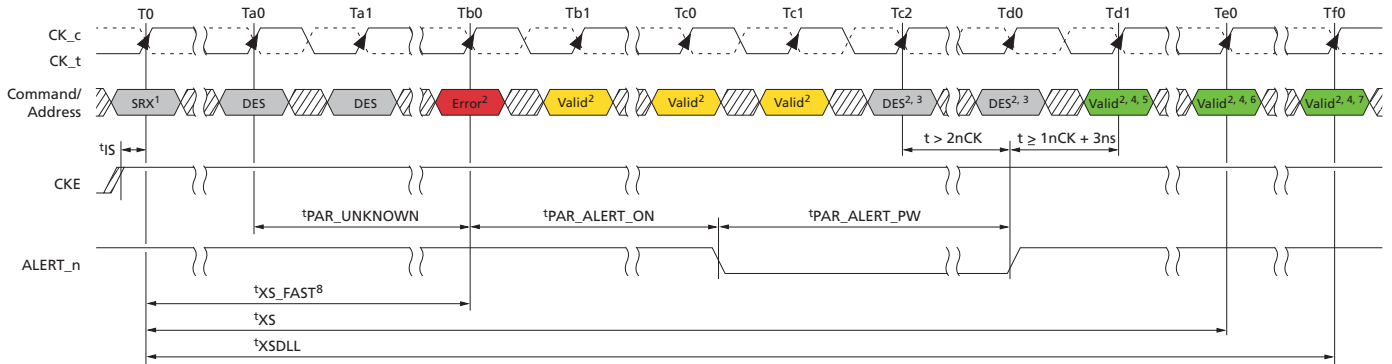
- Notes:
1. DRAM is emptying queues. Precharge all and parity check re-enable finished by  $t_{PAR\_ALERT\_PW}$ .
  2. Command execution is unknown; the corresponding DRAM internal state change may or may not occur. The DRAM controller should consider both cases and make sure that the command sequence meets the specifications.
  3. Normal operation with parity latency and parity checking (CA parity persistent error mode enabled).

Figure 47: CA Parity Error Checking – SRE Attempt



- Notes:
1. Only DESELECT command is allowed.
  2. SELF REFRESH command error. The DRAM masks the intended SRE command and enters precharge power-down.
  3. Normal operation with parity latency (CA parity persistent error mode disabled). Parity checking is off until the parity error status bit cleared.
  4. The controller cannot disable the clock until it has been capable of detecting a possible CA parity error.
  5. Command execution is unknown; the corresponding DRAM internal state change may or may not occur. The DRAM controller should consider both cases and make sure that the command sequence meets the specifications.
  6. Only a DESELECT command is allowed; CKE may go HIGH prior to Tc2 as long as DES commands are issued.

Figure 48: CA Parity Error Checking – SRX Attempt



SRX<sup>1</sup> DES Valid<sup>3,5</sup> Command execution unknown

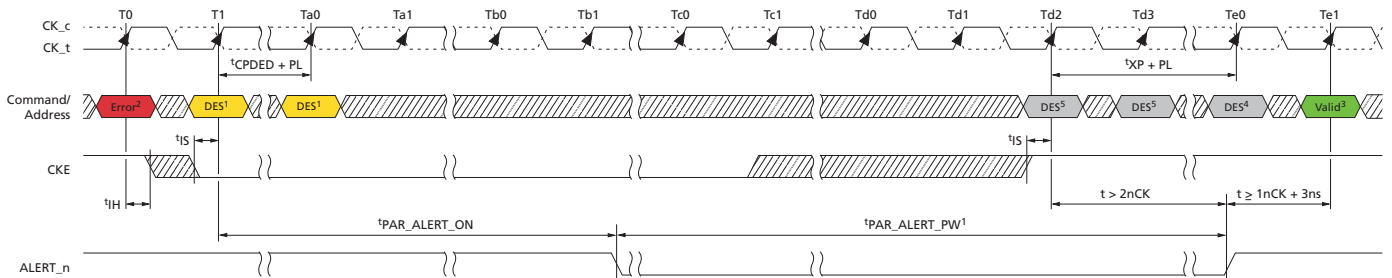
Error<sup>2</sup> Valid<sup>2</sup> Command not executed

Valid<sup>4,5,6,7</sup> Command executed

}} Time Break Don't Care

- Notes:
1. Self refresh abort = disable: MR4 [9] = 0.
  2. Input commands are bounded by  $t_{XSDLL}$ ,  $t_{XS}$ ,  $t_{XS\_ABORT}$ , and  $t_{XS\_FAST}$  timing.
  3. Command execution is unknown; the corresponding DRAM internal state change may or may not occur. The DRAM controller should consider both cases and make sure that the command sequence meets the specifications.
  4. Normal operation with parity latency (CA parity persistent error mode disabled). Parity checking off until parity error status bit cleared.
  5. Only an MRS (limited to those described in the SELF REFRESH Operation section), ZQCS, or ZQCL command is allowed.
  6. Valid commands not requiring a locked DLL.
  7. Valid commands requiring a locked DLL.
  8. This figure shows the case from which the error occurred after  $t_{XS\_FAST}$ . An error may also occur after  $t_{XS\_ABORT}$  and  $t_{XS}$ .

Figure 49: CA Parity Error Checking – PDE/PDX



DES<sup>4</sup> DES<sup>5</sup> Command execution unknown

Error<sup>2</sup> DES<sup>1</sup> Command not executed

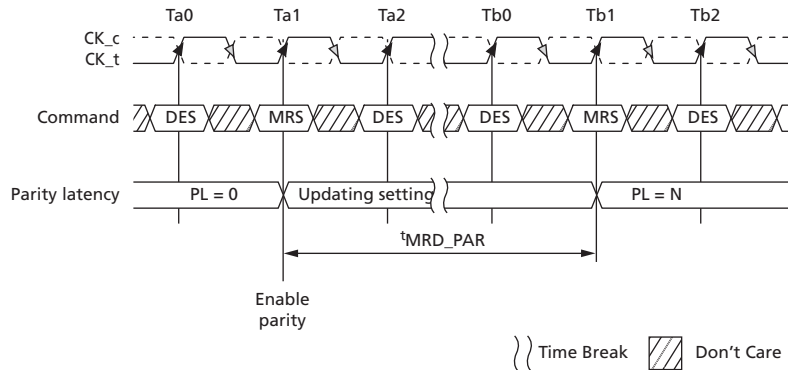
Valid<sup>3</sup> Command executed

Don't Care }} Time Break

- Notes:
1. Only DESELECT command is allowed.
  2. Error could be precharge or activate.
  3. Normal operation with parity latency (CA parity persistent error mode disabled). Parity checking is off until parity error status bit cleared.

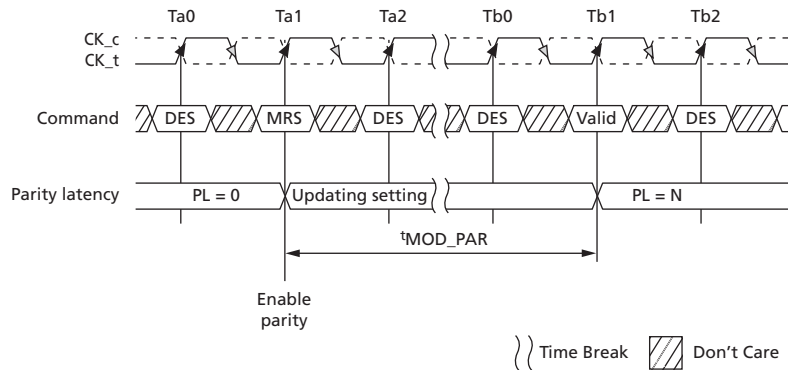
4. Command execution is unknown; the corresponding DRAM internal state change may or may not occur. The DRAM controller should consider both cases and make sure that the command sequence meets the specifications.
5. Only a DESELECT command is allowed; CKE may go HIGH prior to Td2 as long as DES commands are issued.

**Figure 50: Parity Entry Timing Example –  $t^{MRD\_PAR}$**



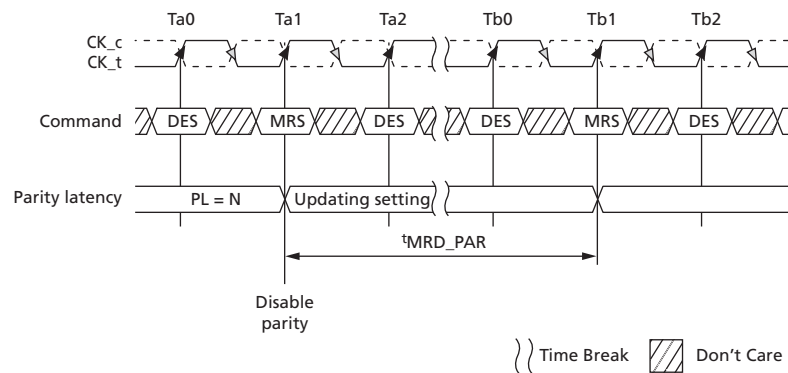
Note: 1.  $t^{MRD\_PAR} = t^{MOD} + N$ ; where N is the programmed parity latency.

**Figure 51: Parity Entry Timing Example –  $t^{MOD\_PAR}$**



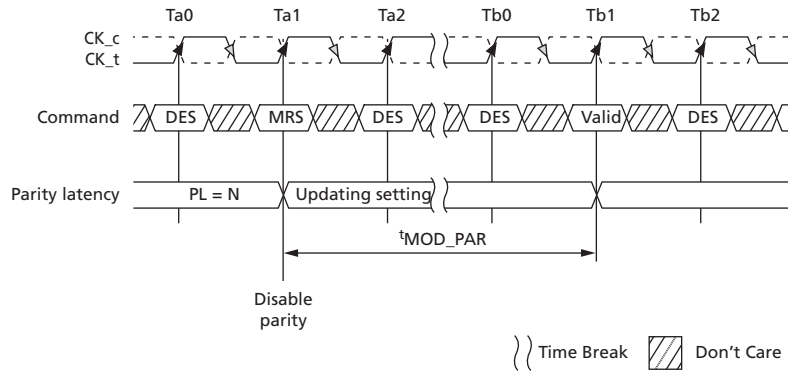
Note: 1.  $t^{MOD\_PAR} = t^{MOD} + N$ ; where N is the programmed parity latency.

**Figure 52: Parity Exit Timing Example –  $t^{MRD\_PAR}$**



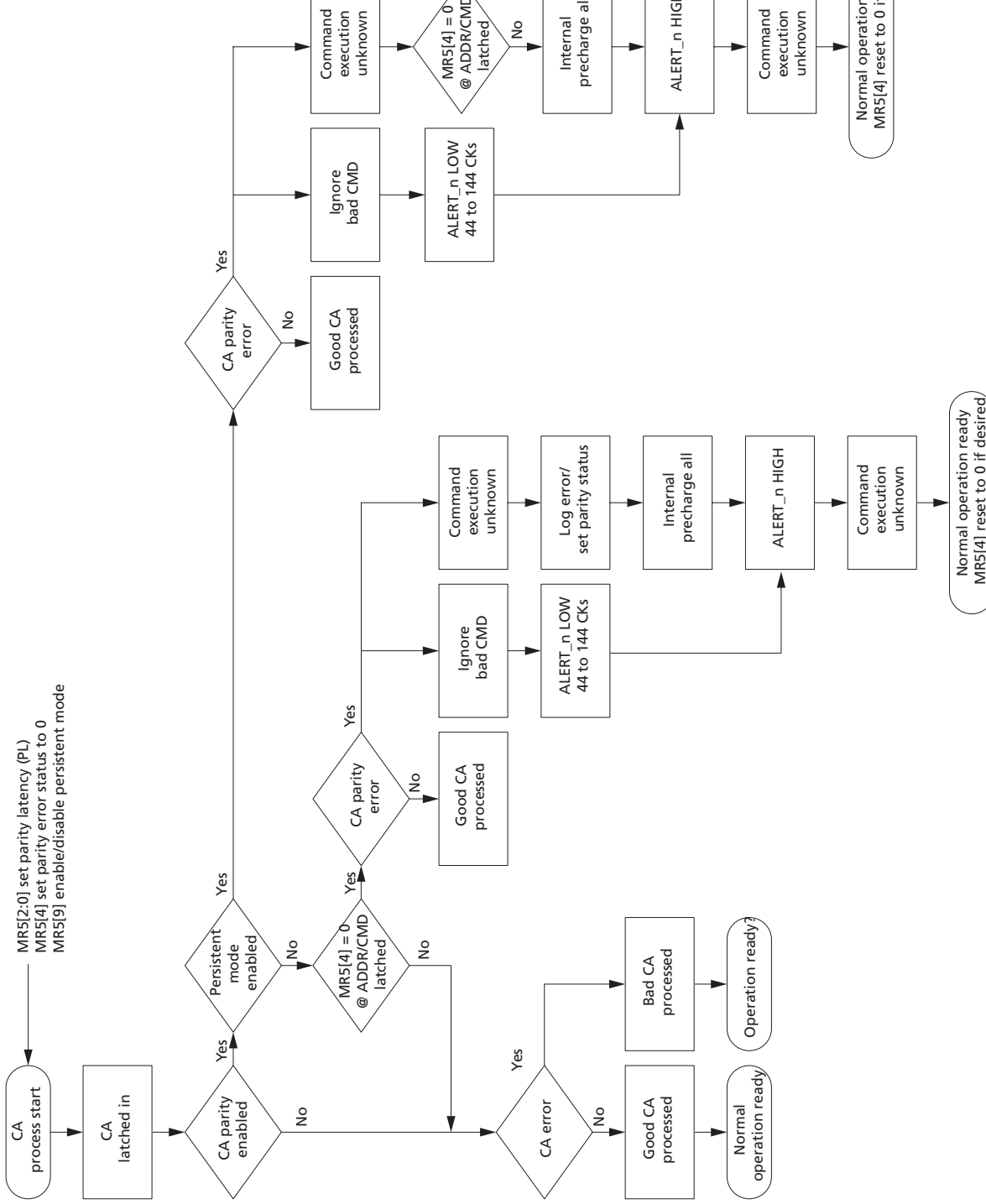
Note: 1.  $t^{MRD\_PAR} = t^{MOD} + N$ ; where N is the programmed parity latency.

Figure 53: Parity Exit Timing Example –  $t_{MOD\_PAR}$



Note: 1.  $t_{MOD\_PAR} = t_{MOD} + N$ ; where N is the programmed parity latency.

**Figure 54: CA Parity Flow Diagram**



## Per-DRAM Addressability

DDR4 allows programmability of a single, specific DRAM on a rank. As an example, this feature can be used to program different ODT or  $V_{REF}$  values on each DRAM on a given rank. Because per-DRAM addressability (PDA) mode may be used to program optimal  $V_{REF}$  for the DRAM, the data set up for first DQ0 transfer or the hold time for the last DQ0 transfer cannot be guaranteed. The DRAM may sample DQ0 on either the first falling or second rising DQS transfer edge. This supports a common implementation between BC4 and BL8 modes on the DRAM. The DRAM controller is required to drive DQ0 to a stable LOW or HIGH state during the length of the data transfer for BC4 and BL8 cases.

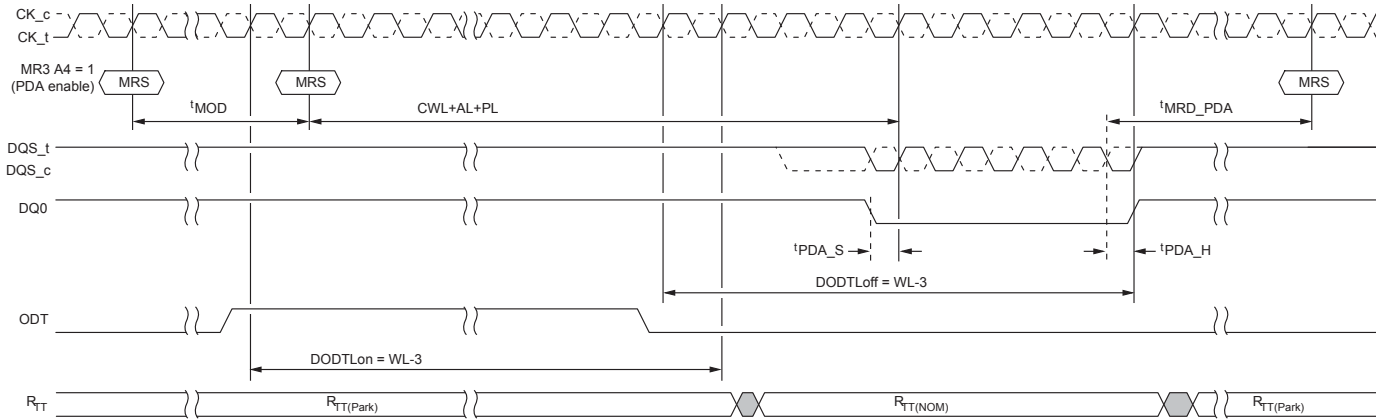
1. Before entering PDA mode, write leveling is required.
  - BL8 or BC4 may be used.
2. Before entering PDA mode, the following MR settings are possible:
  - $R_{TT(Park)}$  MR5 A[8:6] = Enable
  - $R_{TT(NOM)}$  MR1 A[10:8] = Enable
3. Enable PDA mode using MR3 [4] = 1. (The default programmed value of MR3[4] = 0.)
4. In PDA mode, all MRS commands are qualified with DQ0. The device captures DQ0 by using DQS signals. If the value on DQ0 is LOW, the DRAM executes the MRS command. If the value on DQ0 is HIGH, the DRAM ignores the MRS command. The controller can choose to drive all the DQ bits.
5. Program the desired DRAM and mode registers using the MRS command and DQ0.
6. In PDA mode, only MRS commands are allowed.
7. The MODE REGISTER SET command cycle time in PDA mode,  $AL + CWL + BL/2 - 0.5t_{CK} + t_{MRD\_PDA} + PL$ , is required to complete the WRITE operation to the mode register and is the minimum time required between two MRS commands.
8. Remove the device from PDA mode by setting MR3[4] = 0. (This command requires DQ0 = 0.)

**Note:** Removing the device from PDA mode will require programming the entire MR3 when the MRS command is issued. This may impact some PDA values programmed within a rank as the EXIT command is sent to the rank. To avoid such a case, the PDA enable/disable control bit is located in a mode register that does not have any PDA mode controls.

In PDA mode, the device captures DQ0 using DQS signals the same as in a normal WRITE operation; however, dynamic ODT is not supported. Extra care is required for the ODT setting. If  $R_{TT(NOM)}$  MR1 [10:8] = enable, device data termination needs to be controlled by the ODT pin, and applies the same timing parameters (defined below).

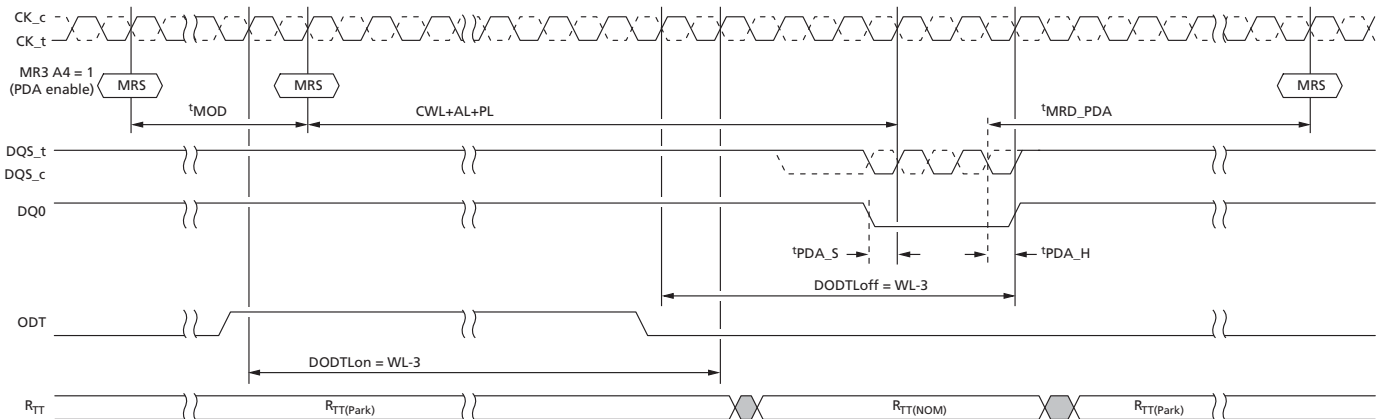
Symbol	Parameter
DODTLon	Direct ODT turnon latency
DODTLoff	Direct ODT turn off latency
$t_{ADC}$	$R_{TT}$ change timing skew
$t_{AONAS}$	Asynchronous $R_{TT(NOM)}$ turn-on delay
$t_{AOFAS}$	Asynchronous $R_{TT(NOM)}$ turn-off delay

**Figure 55: PDA Operation Enabled, BL8**



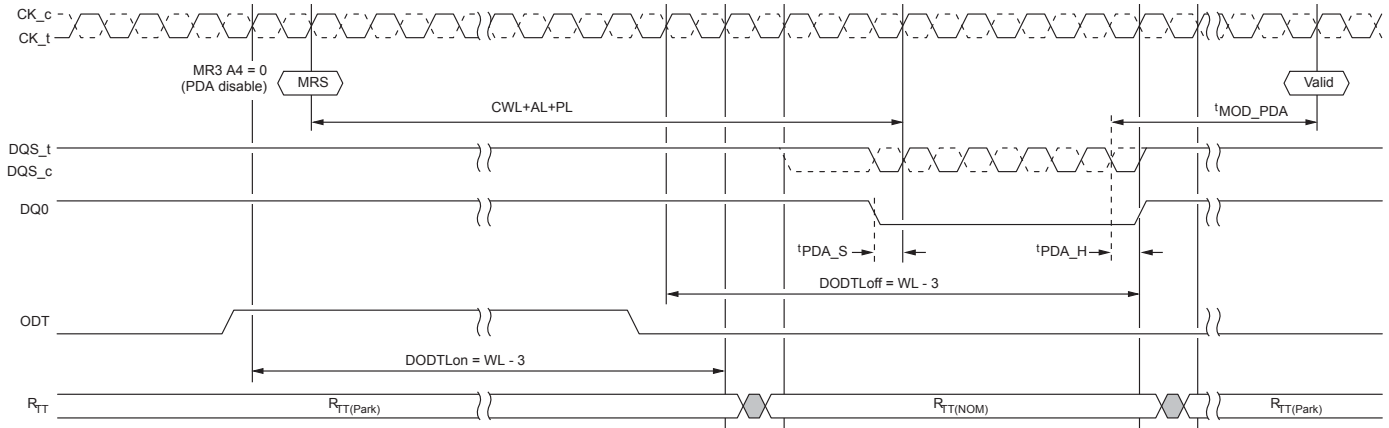
Note: 1.  $R_{TT(Park)}$  = Enable;  $R_{TT(NOM)}$  = Enable; WRITE preamble set =  $2^tCK$ ; and DLL = On.

**Figure 56: PDA Operation Enabled, BC4**



Note: 1.  $R_{TT(Park)}$  = Enable;  $R_{TT(NOM)}$  = Enable; WRITE preamble set =  $2^tCK$ ; and DLL = On.

**Figure 57: MRS PDA Exit**



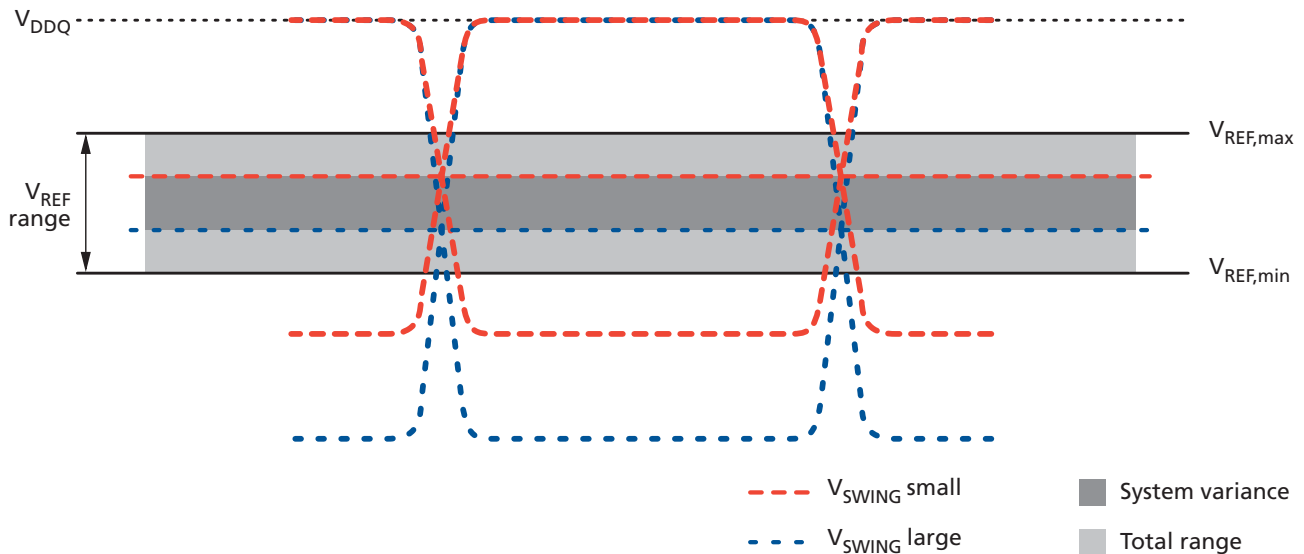
Note: 1. R<sub>TT</sub>(Park) = Enable; R<sub>TT</sub>(NOM) = Enable; WRITE preamble set = 2<sup>t</sup>CK; and DLL = On.

## V<sub>REFDQ</sub> Calibration

The V<sub>REFDQ</sub> level, which is used by the DRAM DQ input receivers, is internally generated. The DRAM V<sub>REFDQ</sub> does not have a default value upon power-up and must be set to the desired value, usually via V<sub>REFDQ</sub> calibration mode. If PDA or PPR modes are used prior to V<sub>REFDQ</sub> calibration, V<sub>REFDQ</sub> should initially be set at the midpoint between the V<sub>DD,max</sub> and the LOW as determined by the driver and ODT termination selected with wide voltage swing on the input levels and setup and hold times of approximately 0.75UI. The memory controller is responsible for V<sub>REFDQ</sub> calibration to determine the best internal V<sub>REFDQ</sub> level. The V<sub>REFDQ</sub> calibration is enabled/disabled via MR6[7], MR6[6] selects Range 1 (60% to 92.5% of V<sub>DDQ</sub>) or Range 2 (45% to 77.5% of V<sub>DDQ</sub>), and an MRS protocol using MR6[5:0] to adjust the V<sub>REFDQ</sub> level up and down. MR6[6:0] bits can be altered using the MRS command if MR6[7] is disabled. The DRAM controller will likely use a series of writes and reads in conjunction with V<sub>REFDQ</sub> adjustments to obtain the best V<sub>REFDQ</sub>, which in turn optimizes the data eye.

The internal V<sub>REFDQ</sub> specification parameters are voltage range, step size, V<sub>REF</sub> step time, V<sub>REF</sub> full step time, and V<sub>REF</sub> valid level. The voltage operating range specifies the minimum required V<sub>REF</sub> setting range for DDR4 SDRAM devices. The minimum range is defined by V<sub>REFDQ,min</sub> and V<sub>REFDQ,max</sub>. As noted, a calibration sequence, determined by the DRAM controller, should be performed to adjust V<sub>REFDQ</sub> and optimize the timing and voltage margin of the DRAM data input receivers. The internal V<sub>REFDQ</sub> voltage value may not be exactly within the voltage range setting coupled with the V<sub>REF</sub> set tolerance; the device must be calibrated to the correct internal V<sub>REFDQ</sub> voltage.

**Figure 58: V<sub>REFDQ</sub> Voltage Range**



## V<sub>REFDQ</sub> Range and Levels

**Table 36: V<sub>REFDQ</sub> Range and Levels**

MR6[5:0]	Range 1 MR6[6] 0	Range 2 MR6[6] 1	MR6[5:0]	Range 1 MR6[6] 0	Range 2 MR6[6] 1
00 0000	60.00%	45.00%	01 1010	76.90%	61.90%
00 0001	60.65%	45.65%	01 1011	77.55%	62.55%
00 0010	61.30%	46.30%	01 1100	78.20%	63.20%
00 0011	61.95%	46.95%	01 1101	78.85%	63.85%
00 0100	62.60%	47.60%	01 1110	79.50%	64.50%
00 0101	63.25%	48.25%	01 1111	80.15%	65.15%
00 0110	63.90%	48.90%	10 0000	80.80%	65.80%
00 0111	64.55%	49.55%	10 0001	81.45%	66.45%
00 1000	65.20%	50.20%	10 0010	82.10%	67.10%
00 1001	65.85%	50.85%	10 0011	82.75%	67.75%
00 1010	66.50%	51.50%	10 0100	83.40%	68.40%
00 1011	67.15%	52.15%	10 0101	84.05%	69.05%
00 1100	67.80%	52.80%	10 0110	84.70%	69.70%
00 1101	68.45%	53.45%	10 0111	85.35%	70.35%
00 1110	69.10%	54.10%	10 1000	86.00%	71.00%
00 1111	69.75%	54.75%	10 1001	86.65%	71.65%
01 0000	70.40%	55.40%	10 1010	87.30%	72.30%
01 0001	71.05%	56.05%	10 1011	87.95%	72.95%
01 0010	71.70%	56.70%	10 1100	88.60%	73.60%
01 0011	72.35%	57.35%	10 1101	89.25%	74.25%
01 0100	73.00%	58.00%	10 1110	89.90%	74.90%
01 0101	73.65%	58.65%	10 1111	90.55%	75.55%
01 0110	74.30%	59.30%	11 0000	91.20%	76.20%
01 0111	74.95%	59.95%	11 0001	91.85%	76.85%
01 1000	75.60%	60.60%	11 0010	92.50%	77.50%
01 1001	76.25%	61.25%	11 0011 to 11 1111 = Reserved		

## V<sub>REFDQ</sub> Step Size

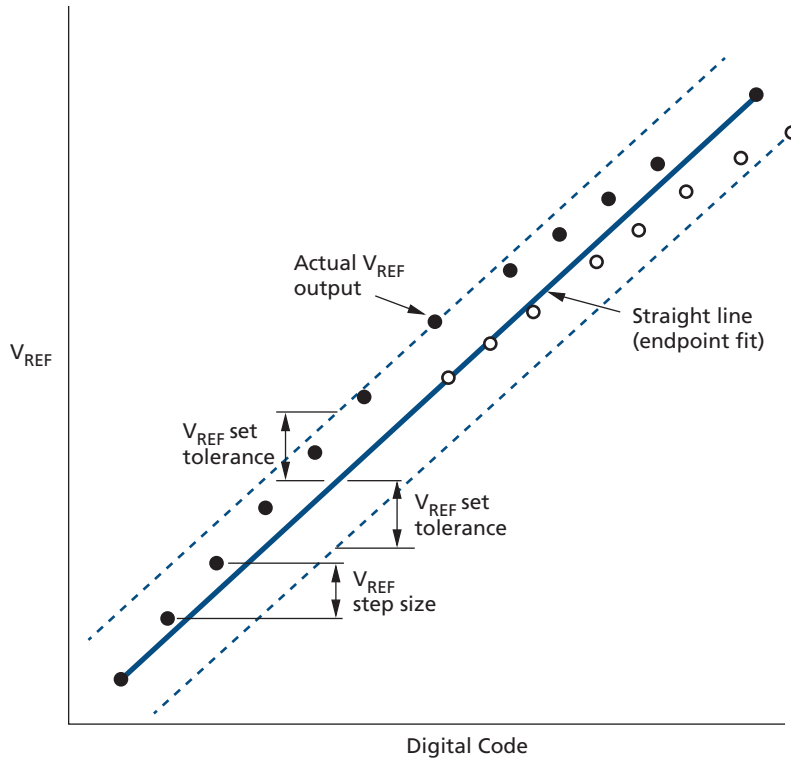
The V<sub>REF</sub> step size is defined as the step size between adjacent steps. V<sub>REF</sub> step size ranges from 0.5% V<sub>DDQ</sub> to 0.8% V<sub>DDQ</sub>. However, for a given design, the device has one value for V<sub>REF</sub> step size that falls within the range.

The V<sub>REF</sub> set tolerance is the variation in the V<sub>REF</sub> voltage from the ideal setting. This accounts for accumulated error over multiple steps. There are two ranges for V<sub>REF</sub> set tolerance uncertainty. The range of V<sub>REF</sub> set tolerance uncertainty is a function of number of steps *n*.

The V<sub>REF</sub> set tolerance is measured with respect to the ideal line, which is based on the MIN and MAX V<sub>REF</sub> value endpoints for a specified range. The internal V<sub>REFDQ</sub> voltage

value may not be exactly within the voltage range setting coupled with the  $V_{REF}$  set tolerance; the device must be calibrated to the correct internal  $V_{REFDQ}$  voltage.

Figure 59: Example of  $V_{REF}$  Set Tolerance and Step Size



Note: 1. Maximum case shown.

### $V_{REFDQ}$ Increment and Decrement Timing

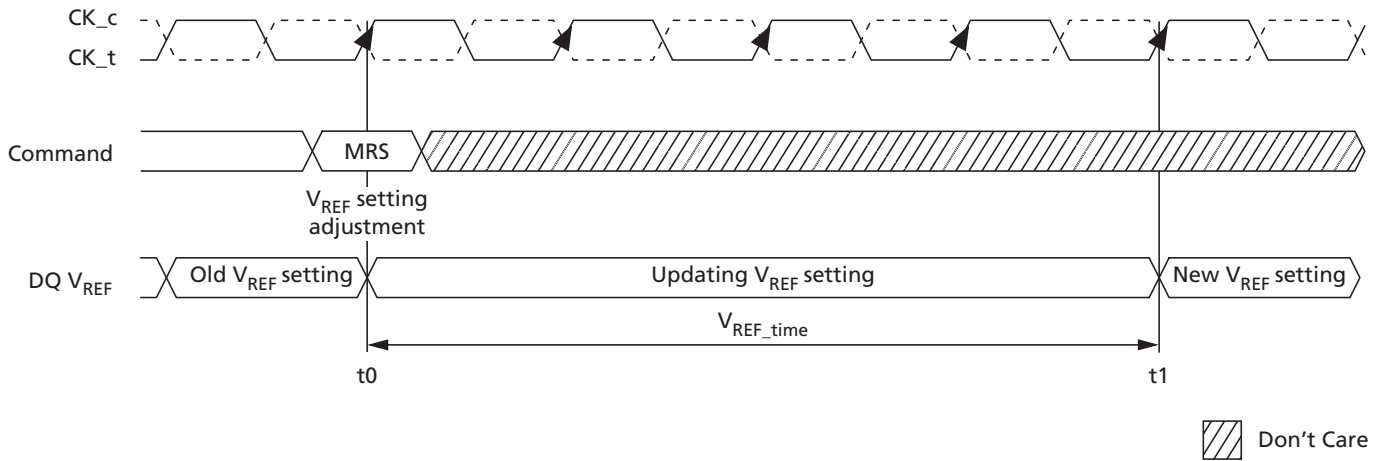
The  $V_{REF}$  increment/decrement step times are defined by  $V_{REF,time}$ .  $V_{REF,time}$  is defined from  $t_0$  to  $t_1$ , where  $t_1$  is referenced to the  $V_{REF}$  voltage at the final DC level within the  $V_{REF}$  valid tolerance ( $V_{REFval\_tol}$ ). The  $V_{REF}$  valid level is defined by  $V_{REFval}$  tolerance to qualify the step time  $t_1$ . This parameter is used to insure an adequate RC time constant behavior of the voltage level change after any  $V_{REF}$  increment/decrement adjustment.

Note:

$t_0$  is referenced to the MRS command clock

$t_1$  is referenced to  $V_{REF,tol}$

Figure 60: V<sub>REFDQ</sub> Timing Diagram for V<sub>REF,time</sub> Parameter



V<sub>REFDQ</sub> calibration mode is entered via an MRS command, setting MR6[7] to 1 (0 disables V<sub>REFDQ</sub> calibration mode) and setting MR6[6] to either 0 or 1 to select the desired range (MR6[5:0] are "Don't Care"). After V<sub>REFDQ</sub> calibration mode has been entered, V<sub>REFDQ</sub> calibration mode legal commands may be issued once t<sub>VREFDQE</sub> has been satisfied. Legal commands for V<sub>REFDQ</sub> calibration mode are ACT, WR, WRA, RD, RDA, PRE, DES, and MRS to set V<sub>REFDQ</sub> values, and MRS to exit V<sub>REFDQ</sub> calibration mode. Also, after V<sub>REFDQ</sub> calibration mode has been entered, “dummy” WRITE commands are allowed prior to adjusting the V<sub>REFDQ</sub> value the first time V<sub>REFDQ</sub> calibration is performed after initialization.

Setting V<sub>REFDQ</sub> values requires MR6[7] be set to 1 and MR6[6] be unchanged from the initial range selection; MR6[5:0] may be set to the desired V<sub>REFDQ</sub> values. If MR6[7] is set to 0, MR6[6:0] are not written. V<sub>REF,time-short</sub> OR V<sub>REF,time-long</sub> must be satisfied after each MR6 command to set V<sub>REFDQ</sub> value before the internal V<sub>REFDQ</sub> value is valid.

If PDA mode is used in conjunction with V<sub>REFDQ</sub> calibration, the PDA mode requirement that only MRS commands are allowed while PDA mode is enabled is not waived. That is, the only V<sub>REFDQ</sub> calibration mode legal commands noted above that may be used are the MRS commands: MRS to set V<sub>REFDQ</sub> values and MRS to exit V<sub>REFDQ</sub> calibration mode.

The last MR6[6:0] setting written to MR6 prior to exiting V<sub>REFDQ</sub> calibration mode is the range and value used for the internal V<sub>REFDQ</sub> setting. V<sub>REFDQ</sub> calibration mode may be exited when the DRAM is in idle state. After the MRS command to exit V<sub>REFDQ</sub> calibration mode has been issued, DES must be issued until t<sub>VREFDQX</sub> has been satisfied where any legal command may then be issued. V<sub>REFDQ</sub> setting should be updated if the die temperature changes too much from the calibration temperature.

The following are typical script when applying the above rules for V<sub>REFDQ</sub> calibration routine when performing V<sub>REFDQ</sub> calibration in Range 1:

- MR6[7:6]10 [5:0]XXXXXXX.
- Subsequent legal commands while in V<sub>REFDQ</sub> calibration mode: ACT, WR, WRA, RD, RDA, PRE, DES, and MRS (to set V<sub>REFDQ</sub> values and exit V<sub>REFDQ</sub> calibration mode).

- All subsequent V<sub>REFDQ</sub> calibration MR setting commands are MR6[7:6]10 [5:0]VVVVVV.
  - "VVVVVV" are desired settings for V<sub>REFDQ</sub>.
- Issue ACT/WR/RD looking for pass/fail to determine V<sub>CENT</sub> (midpoint) as needed.
- To exit V<sub>REFDQ</sub> calibration, the last two V<sub>REFDQ</sub> calibration MR commands are:
  - MR6[7:6]10 [5:0]VVVVVV\* where VVVVVV\* = desired value for V<sub>REFDQ</sub>.
  - MR6[7]0 [6:0]XXXXXXXX to exit V<sub>REFDQ</sub> calibration mode.

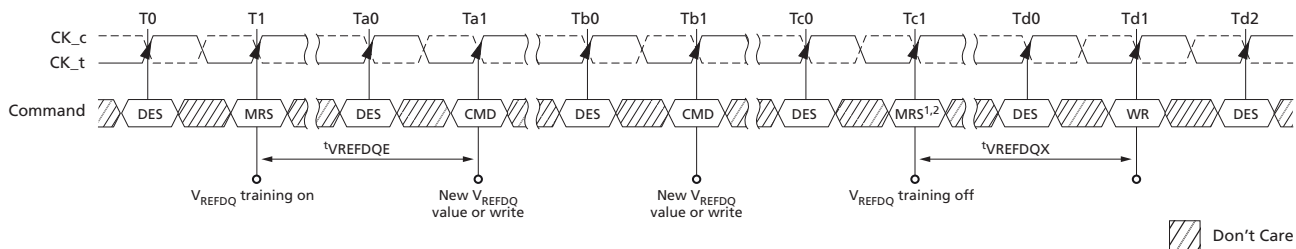
The following are typical script when applying the above rules for V<sub>REFDQ</sub> calibration routine when performing V<sub>REFDQ</sub> calibration in Range 2:

- MR6[7:6]11 [5:0]XXXXXXXX.
  - Subsequent legal commands while in V<sub>REFDQ</sub> calibration mode: ACT, WR, WRA, RD, RDA, PRE, DES, and MRS (to set V<sub>REFDQ</sub> values and exit V<sub>REFDQ</sub> calibration mode).
- All subsequent V<sub>REFDQ</sub> calibration MR setting commands are MR6[7:6]11 [5:0]VVVVVV.
  - "VVVVVV" are desired settings for V<sub>REFDQ</sub>.
- Issue ACT/WR/RD looking for pass/fail to determine V<sub>CENT</sub> (midpoint) as needed.
- To exit V<sub>REFDQ</sub> calibration, the last two V<sub>REFDQ</sub> calibration MR commands are:
  - MR6[7:6]11 [5:0]VVVVVV\* where VVVVVV\* = desired value for V<sub>REFDQ</sub>.
  - MR6[7]0 [6:0]XXXXXXXX to exit V<sub>REFDQ</sub> calibration mode.

**Note:**

Range may only be set or changed when entering V<sub>REFDQ</sub> calibration mode; changing range while in or exiting V<sub>REFDQ</sub> calibration mode is illegal.

**Figure 61: V<sub>REFDQ</sub> Training Mode Entry and Exit Timing Diagram**



- Notes:
1. New V<sub>REFDQ</sub> values are not allowed with an MRS command during calibration mode entry.
  2. Depending on the step size of the latest programmed V<sub>REF</sub> value, V<sub>REF</sub> must be satisfied before disabling V<sub>REFDQ</sub> training mode.

Figure 62:  $V_{REF}$  Step: Single Step Size Increment Case

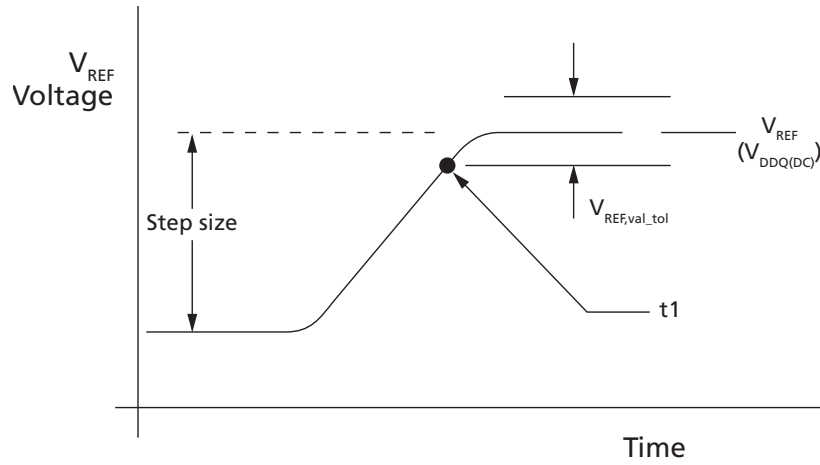
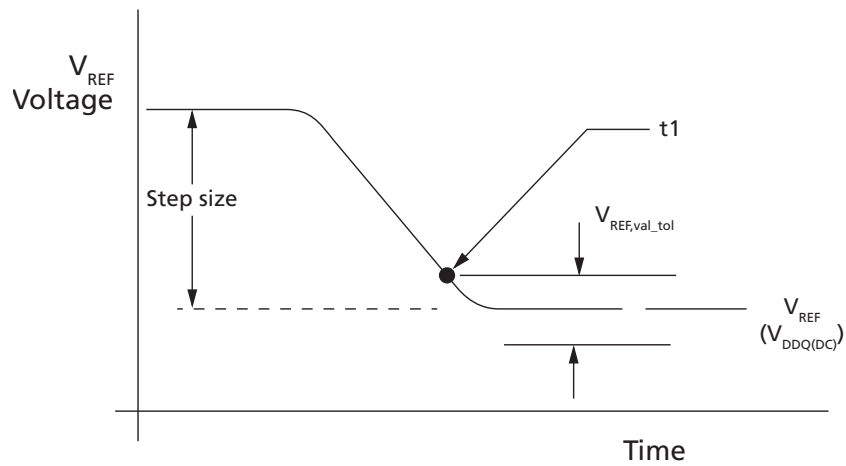
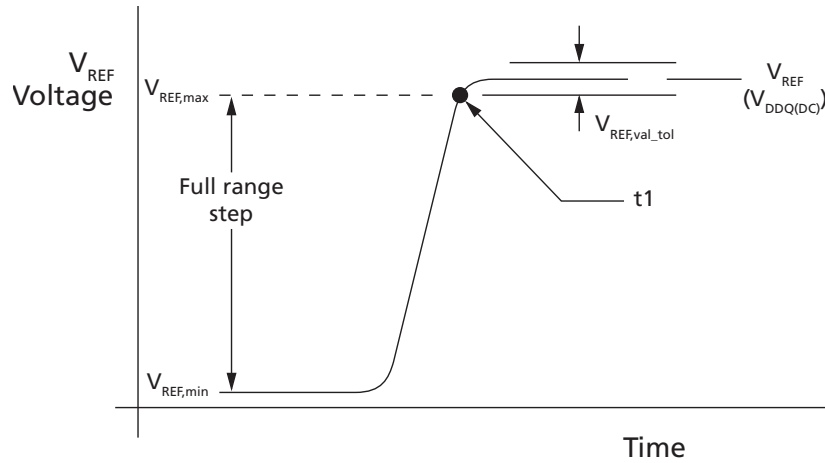


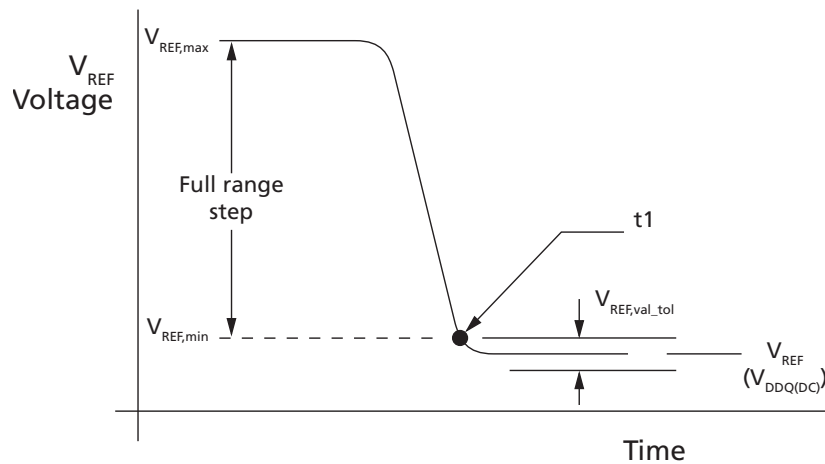
Figure 63:  $V_{REF}$  Step: Single Step Size Decrement Case



**Figure 64: V<sub>REF</sub> Full Step: From V<sub>REF,min</sub> to V<sub>REF,max</sub> Case**



**Figure 65: V<sub>REF</sub> Full Step: From V<sub>REF,max</sub> to V<sub>REF,min</sub> Case**



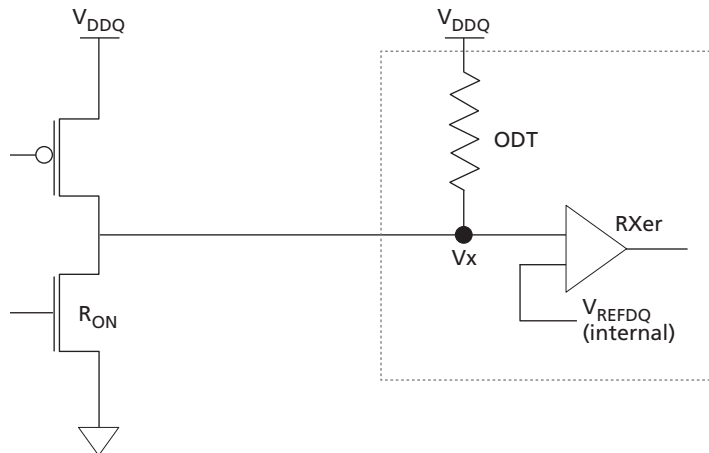
### V<sub>REFDQ</sub> Target Settings

The V<sub>REFDQ</sub> initial settings are largely dependant on the ODT termination settings. The table below shows all of the possible initial settings available for V<sub>REFDQ</sub> training; it is unlikely the lower ODT settings would be used in most cases.

**Table 37: V<sub>REFDQ</sub> Settings (V<sub>DDQ</sub> = 1.2V)**

R <sub>ON</sub>	ODT	V <sub>x</sub> - V <sub>IN</sub> LOW (mV)	V <sub>REFDQ</sub> (mv)	V <sub>REFDQ</sub> (%V <sub>DDQ</sub> )
34 ohm	34 ohm	600	900	75%
	40 ohm	550	875	73%
	48 ohm	500	850	71%
	60 ohm	435	815	68%
	80 ohm	360	780	65%
	120 ohm	265	732	61%
	240 ohm	150	675	56%
48 ohm	34 ohm	700	950	79%
	40 ohm	655	925	77%
	48 ohm	600	900	75%
	60 ohm	535	865	72%
	80 ohm	450	825	69%
	120 ohm	345	770	64%
	240 ohm	200	700	58%

**Figure 66: V<sub>REFDQ</sub> Equivalent Circuit**



## Connectivity Test Mode

Connectivity test (CT) mode is similar to boundary scan testing but is designed to significantly speed up the testing of electrical continuity of pin interconnections between the device and the memory controller on the PC boards. Designed to work seamlessly with any boundary scan device, CT mode is supported in all x16 devices, and on select x4 and x8 devices (JEDEC specifies CT mode for x4 and x8 as an optional feature on 8Gb and above).

Contrary to other conventional shift-register-based test modes, where test patterns are shifted in and out of the memory devices serially during each clock, the CT mode allows test patterns to be entered on the test input pins in parallel and the test results to be extracted from the test output pins of the device in parallel. These two functions are also performed at the same time, significantly increasing the speed of the connectivity check. When placed in CT mode, the device appears as an asynchronous device to the external controlling agent. After the input test pattern is applied, the connectivity test results are available for extraction in parallel at the test output pins after a fixed propagation delay time.

**Note:** A reset of the device is required after exiting CT mode (see RESET and Initialization Procedure).

## Pin Mapping

Only digital pins can be tested using the CT mode. For the purposes of a connectivity check, all the pins used for digital logic in the device are classified as one of the following types:

- **Test enable (TEN):** When asserted HIGH, this pin causes the device to enter CT mode. In CT mode, the normal memory function inside the device is bypassed and the I/O pins appear as a set of test input and output pins to the external controlling agent. Additionally, the device will set the internal  $V_{REFDQ}$  to  $V_{DDQ} \times 0.5$  during CT mode (this is the only time the DRAM takes direct control over setting the internal  $V_{REFDQ}$ ). The TEN pin is dedicated to the connectivity check function and will not be used during normal device operation.
- **Chip select (CS\_n):** When asserted LOW, this pin enables the test output pins in the device. When de-asserted, these output pins will be High-Z. The CS\_n pin in the device serves as the CS\_n pin in CT mode.
- **Test input:** A group of pins used during normal device operation designated as test input pins. These pins are used to enter the test pattern in CT mode.
- **Test output:** A group of pins used during normal device operation designated as test output pins. These pins are used for extraction of the connectivity test results in CT mode.
- **RESET\_n:** This pin must be fixed high level during CT mode, as in normal function.

**Table 38: Connectivity Mode Pin Description and Switching Levels**

CT Mode Pins	Pin Name During Normal Memory Operation	Switching Level	Notes	
Test enable	TEN	CMOS (20%/80% V <sub>DD</sub> )	1, 2	
Chip select	CS <sub>n</sub>	V <sub>REFCA</sub> ±200mV	3	
Test input	A	BA[1:0], BG[1:0], A[9:0], A10/AP, A11, A12/BC <sub>n</sub> , A13, WE <sub>n</sub> /A14, CAS <sub>n</sub> /A15, RAS <sub>n</sub> /A16, CKE, ACT <sub>n</sub> , ODT, CLK <sub>t</sub> , CLK <sub>c</sub> , PAR	V <sub>REFCA</sub> ±200mV	3
	B	LDM <sub>n</sub> /LDBI <sub>n</sub> , UDM <sub>n</sub> /LDBI <sub>n</sub> ; DM <sub>n</sub> /DBI <sub>n</sub>	V <sub>REFDQ</sub> ±200mV	4
	C	ALERT <sub>n</sub>	CMOS (20%/80% V <sub>DD</sub> )	2, 5
	D	RESET <sub>n</sub>	CMOS (20%/80% V <sub>DD</sub> )	2
Test output	DQ[15:0], UDQS <sub>t</sub> , UDQS <sub>c</sub> , LDQS <sub>t</sub> , LDQS <sub>c</sub> ; DQS <sub>t</sub> , DQS <sub>c</sub>	V <sub>TT</sub> ±100mV	6	

- Notes:
1. TEN: Connectivity test mode is active when TEN is HIGH and inactive when TEN is LOW. TEN must be LOW during normal operation.
  2. CMOS is a rail-to-rail signal with DC HIGH at 80% and DC LOW at 20% of V<sub>DD</sub> (960mV for DC HIGH and 240mV for DC LOW.)
  3. V<sub>REFCA</sub> should be V<sub>DD</sub>/2.
  4. V<sub>REFDQ</sub> should be V<sub>DDQ</sub>/2.
  5. ALERT<sub>n</sub> switching level is not a final setting.
  6. V<sub>TT</sub> should be set to V<sub>DD</sub>/2.

### Minimum Terms Definition for Logic Equations

The test input and output pins are related by the following equations, where INV denotes a logical inversion operation and XOR a logical exclusive OR operation:

$$\begin{aligned}
 MT0 &= \text{XOR}(A1, A6, \text{PAR}) \\
 MT1 &= \text{XOR}(A8, \text{ALERT}_n, A9) \\
 MT2 &= \text{XOR}(A2, A5, A13) \\
 MT3 &= \text{XOR}(A0, A7, A11) \\
 MT4 &= \text{XOR}(\text{CK}_c, \text{ODT}, \text{CAS}_n/A15) \\
 MT5 &= \text{XOR}(\text{CKE}, \text{RAS}_n/A16, A10/AP) \\
 MT6 &= \text{XOR}(\text{ACT}_n, A4, \text{BA}1) \\
 MT7 &= \text{x16: XOR}(\text{DMU}_n/\text{DBIU}_n, \text{DML}_n/\text{DBIL}_n, \text{CK}_t) \\
 &= \text{x8: XOR}(\text{BG}1, \text{DML}_n/\text{DBIL}_n, \text{CK}_t) \\
 &= \text{x4: XOR}(\text{BG}1, \text{CK}_t) \\
 MT8 &= \text{XOR}(\text{WE}_n/A14, A12 / \text{BC}, \text{BA}0) \\
 MT9 &= \text{XOR}(\text{BG}0, A3, \text{RESET}_n \text{ and } \text{TEN})
 \end{aligned}$$

### Logic Equations for a x4 Device, When Supported

$$\begin{aligned}
 DQ0 &= \text{XOR}(MT0, MT1) \\
 DQ1 &= \text{XOR}(MT2, MT3) \\
 DQ2 &= \text{XOR}(MT4, MT5) \\
 DQ3 &= \text{XOR}(MT6, MT7) \\
 DQS_t &= MT8 \\
 DQS_c &= MT9
 \end{aligned}$$

### Logic Equations for a x8 Device, When Supported

DQ0 = MT0	DQ5 = MT5
DQ1 = MT1	DQ6 = MT6
DQ2 = MT2	DQ7 = MT7
DQ3 = MT3	DQS_t = MT8
DQ4 = MT4	DQS_t = MT9

### Logic Equations for a x16 Device

DQ0 = MT0	DQ10 = INV DQ2
DQ1 = MT1	DQ11 = INV DQ3
DQ2 = MT2	DQ12 = INV DQ4
DQ3 = MT3	DQ13 = INV DQ5
DQ4 = MT4	DQ14 = INV DQ6
DQ5 = MT5	DQ15 = INV DQ7
DQ6 = MT6	LDQS_t = MT8
DQ7 = MT7	LDQS_c = MT9
DQ8 = INV DQ0	UDQS_t = INV LDQS_t
DQ9 = INV DQ1	UDQS_c = INV LDQS_c

### CT Input Timing Requirements

Prior to the assertion of the TEN pin, all voltage supplies must be valid and stable. Upon the assertion of the TEN pin HIGH with RESET\_n, CKE and CS\_n held HIGH; CLK\_t, CLK\_c, and CKE signals become test inputs within  $t_{CTECT\_Valid}$ . The remaining CT inputs become valid  $t_{CT\_Enable}$  after TEN goes HIGH when CS\_n allows input to begin sampling, provided inputs were valid for at least  $t_{CT\_Valid}$ . While in CT mode, refresh activities in the memory arrays are not allowed; they are initiated either externally (auto refresh) or internally (self refresh).

The TEN pin may be asserted after the DRAM has completed power-on. After the DRAM is initialized and  $V_{REFDQ}$  is calibrated, CT mode may no longer be used. The TEN pin may be de-asserted at any time in CT mode. Upon exiting CT mode, the states and the integrity of the original content of the memory array are unknown. A full reset of the memory device is required.

After CT mode has been entered, the output signals will be stable within  $t_{CT\_Valid}$  after the test inputs have been applied as long as TEN is maintained HIGH and CS\_n is maintained LOW.



## Post Package Repair and Soft Post Package Repair

### Post Package Repair

DDR4 post package repair (PPR) and soft post package repair (sPPR) repairs 1 row per bank group.

JEDEC has PPR as optional for 4Gb and sPPR as optional for 4Gb and 8Gb parts.

PPR support is identified via an MPR read from MPR Page 2, MPR0[7]. PPR is a permanent repair; once repaired, it cannot be reversed. sPPR support is identified via an MPR read from MPR Page 2, MPR0[6]. sPPR is NOT a permanent repair; even though repaired, the repair can be reversed or made permanent via PPR. The controller provides the failing row address in the PPR/sPPR sequence to the device to perform the row repair.

PPR and sPPR may not be enabled at the same time.

PPR defines two fail row address repair sequence modes and users can choose to use either command sequence.

The first command sequence uses a WRA command and ensures data retention with a REFRESH operation (except for the bank containing the row that is being repaired). The second command sequence uses a WR command (a REFRESH operation can't be performed in this command sequence). The second command sequence doesn't ensure data retention for the target DRAM.

For x16 DRAMs, the lower byte and upper byte are treated as separate bytes; thus each is viewed as a separate x8 device.

### PPR Row Repair

All banks must be precharged and idle. DBI and CRC modes must be disabled. PPR is disabled with MR4[13] = 0, which is the normal state, and PPR is enabled with MR4[13] = 1, which is the PPR enabled state. There are two forms of PPR mode: 1) WRA initiated (allows refresh of all banks not under repair, and 2) WR initiated (refresh of any bank is not allowed). Both forms of PPR have the same entry requirement as defined in the sections below.

#### PPR Row Repair - Entry

As stated above, all banks must be precharged and idle. DBI and CRC modes must be disabled, and all timings must be followed as shown in the timing diagram that follows.

All other commands except those listed in the following sequences are illegal.

1. Issue MR4[13] 1 to enter PPR mode enable.
  - a. All DQ are driven HIGH.
2. Issue four consecutive guard key commands (shown in the table below) to MR0 with each command separated by tMOD.
  - a. Any interruption of the key sequence by other commands, such as ACT, WR, RD, PRE, REF, ZQ, and NOP, are not allowed.
  - b. If the guard key bits are not entered in the required order or interrupted with other MR commands, PPR will not be enabled, and the programming cycle will result in a NOP.

- c. When the PPR entry sequence is interrupted and followed by ACT and WR commands, these commands will be conducted as normal DRAM commands.
- d. JEDEC allows A6:0 to be "Don't Care" on 4Gb and 8Gb devices.

**Table 39: PPR MR0 Guard Key Settings**

MR0	BG1:0	BA1:0	A17:12	A11	A10	A9	A8	A7	A6:0
First guard key	0	0	xxxxxx	1	1	0	0	1	1111111
Second guard key	0	0	xxxxxx	0	1	1	1	1	1111111
Third Guard key	0	0	xxxxxx	1	0	1	1	1	1111111
Fourth guard key	0	0	xxxxxx	0	0	1	1	1	1111111

**PPR Row Repair – WRA Initiated (REF Commands Allowed)**

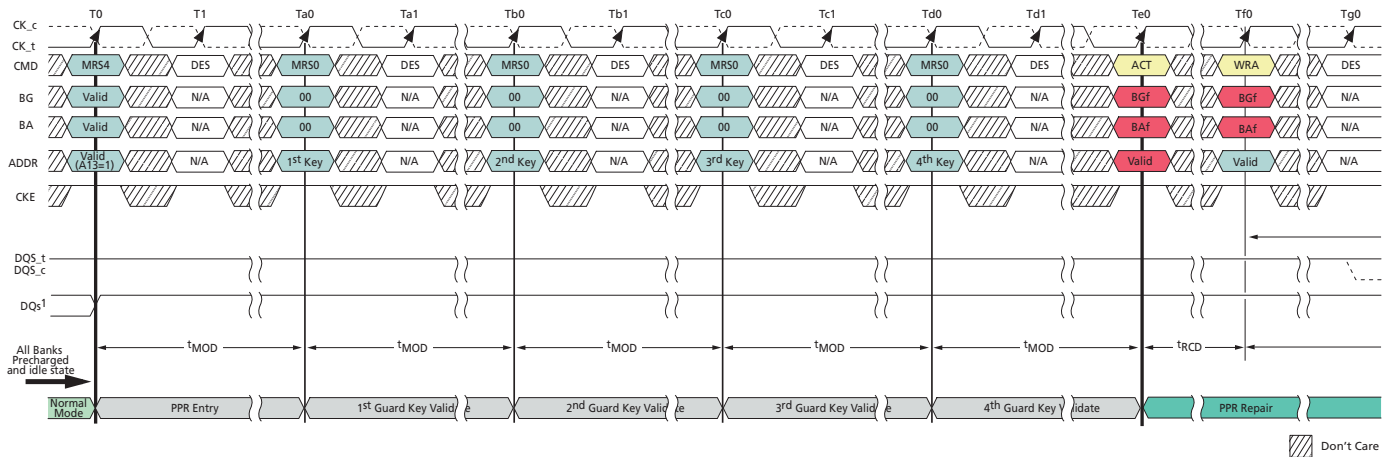
1. Issue an ACT command with failing BG and BA with the row address to be repaired.
2. Issue a WRA command with BG and BA of failing row address.
  - a. The address must be at valid levels, but the address is "Don't Care."
3. All DQ of the target DRAM should be driven LOW for  $4nCK$  (bit 0 through bit 7) after WL ( $WL = CWL + AL + PL$ ) in order for PPR to initiate repair.
  - a. Repair **will be** initiated to the target DRAM only if all DQ during bit 0 through bit 7 are LOW.
  - b. Repair **will not be** initiated to the target DRAM if any DQ during bit 0 through bit 7 is HIGH.
    1. JEDEC states: All DQs of target DRAM should be LOW for  $4^tCK$ . If HIGH is driven to all DQs of a DRAM consecutively for equal to or longer than  $2^tCK$ , then DRAM does not conduct PPR and retains data if REF command is properly issued; if all DQs are neither LOW for  $4^tCK$  nor HIGH for equal to or longer than  $2^tCK$ , then PPR mode execution is unknown.
  - c. DQS should function normally.
4. REF command may be issued anytime after the WRA command followed by  $WL + 4nCK + ^tWR + ^tRP + 1^tCK$ .
  - a. Multiple REF commands are issued at a rate of  $^tREFI$  or  $^tREFI/2$ , however back-to-back REF commands must be separated by at least  $^tREFI/4$  when the DRAM is in PPR mode.
  - b. All banks except the bank under repair will perform refresh.
5. Issue PRE after  $^tPGM$  time so that the device can repair the target row during  $^tPGM$  time.
  - a. Wait  $^tPGM\_Exit$  after PRE to allow the device to recognize the repaired target row address.
6. Issue MR4[13] 0 command to PPR mode disable.
  - a. Wait  $^tPGMPST$  for PPR mode exit to complete.
  - b. After  $^tPGMPST$  has expired, any valid command may be issued.

The entire sequence from PPR mode enable through PPR mode disable may be repeated if more than one repair is to be done.

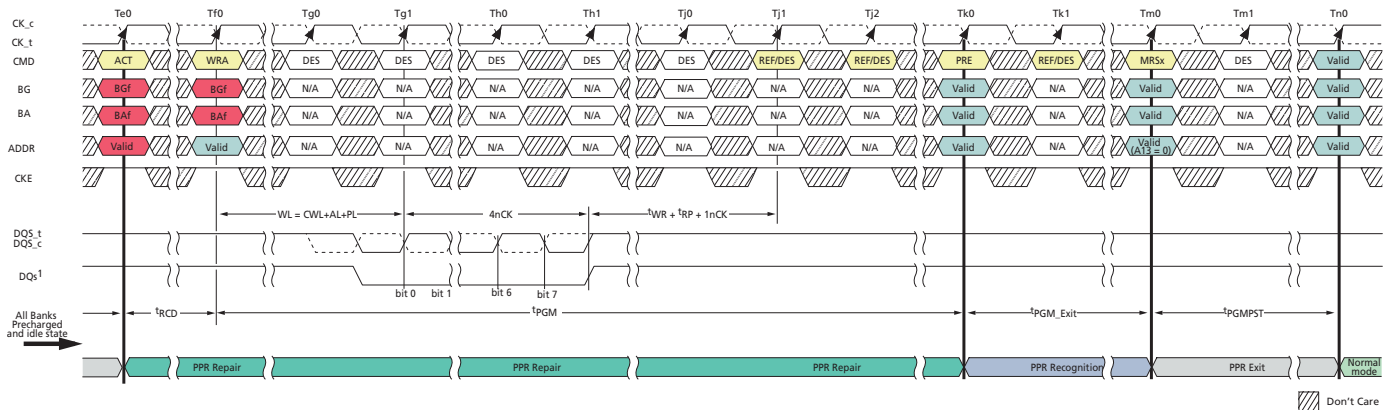
After completing PPR mode, MR0 must be re-programmed to a prePPR mode state if the device is to be accessed.

After PPR mode has been exited, the DRAM controller can confirm if the target row was repaired correctly by writing data into the target row and reading it back.

**Figure 68: PPR WRA – Entry**



**Figure 69: PPR WRA – Repair and Exit**



**PPR Row Repair – WR Initiated (REF Commands NOT Allowed)**

1. Issue an ACT command with failing BG and BA with the row address to be repaired.
2. Issue a WR command with BG and BA of failing row address.
  - a. The address must be at valid levels, but the address is "Don't Care."
3. All DQ of the target DRAM should be driven LOW for  $4nCK$  (bit 0 through bit 7) after WL ( $WL = CWL + AL + PL$ ) in order for PPR to initiate repair.
  - a. Repair **will be** initiated to the target DRAM only if all DQ during bit 0 through bit 7 are LOW.
  - b. Repair **will not be** initiated to the target DRAM if any DQ during bit 0 through bit 7 is HIGH.
    1. JEDEC states: All DQs of target DRAM should be LOW for  $4^tCK$ . If HIGH is driven to all DQs of a DRAM consecutively for equal to or longer than  $2^tCK$ , then DRAM does not conduct PPR and retains data if REF command is properly issued; if all DQs are neither LOW for  $4^tCK$  nor HIGH for equal to or longer than  $2^tCK$ , then PPR mode execution is unknown.
  - c. DQS should function normally.
4. REF commands may NOT be issued at anytime while in PPT mode.

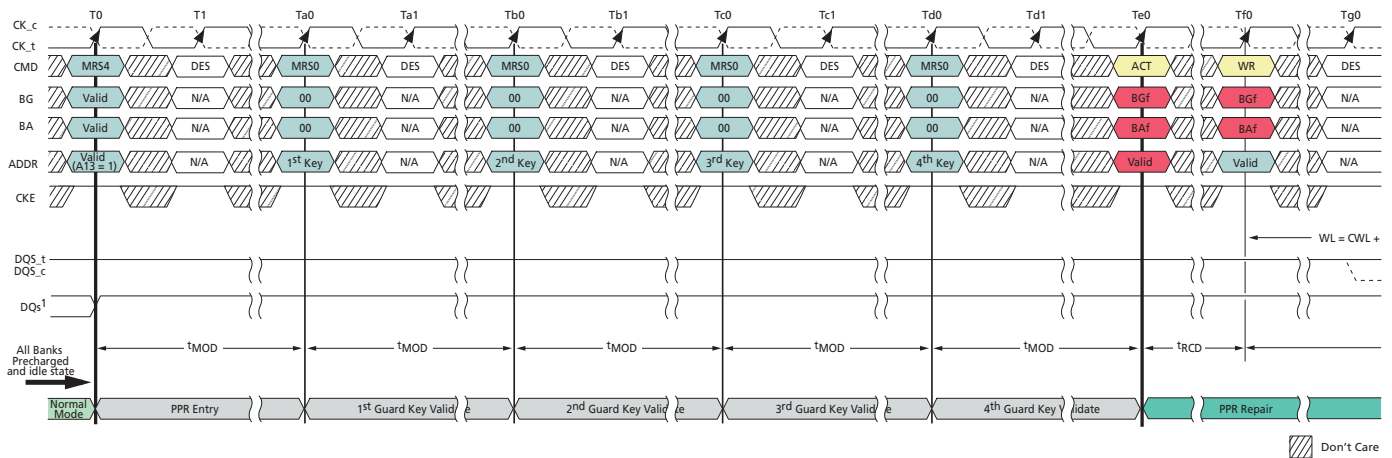
5. Issue PRE after  $t^1PGM$  time so that the device can repair the target row during  $t^1PGM$  time.
  - a. Wait  $t^1PGM\_Exit$  after PRE to allow the device to recognize the repaired target row address.
6. Issue MR4[13] 0 command to PPR mode disable.
  - a. Wait  $t^1PGMPST$  for PPR mode exit to complete.
  - b. After  $t^1PGMPST$  has expired, any valid command may be issued.

The entire sequence from PPR mode enable through PPR mode disable may be repeated if more than one repair is to be done.

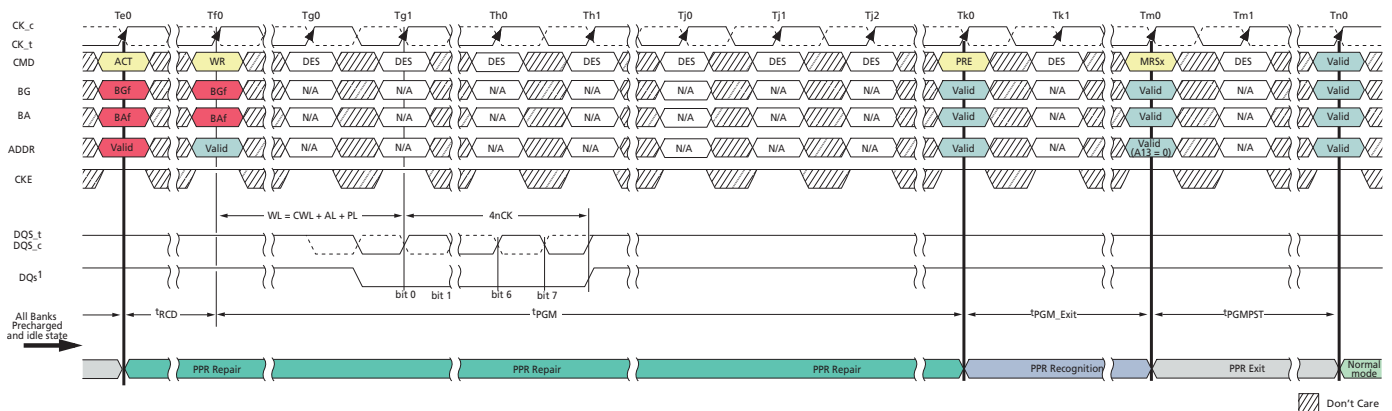
After completing PPR mode, MR0 must be re-programmed to a prePPR mode state if the device is to be accessed.

After PPR mode has been exited, the DRAM controller can confirm if the target row was repaired correctly by writing data into the target row and reading it back.

**Figure 70: PPR WR – Entry**



**Figure 71: PPR WR – Repair and Exit**



**Table 40: DDR4 PPR Timing Parameters DDR4-1600 through DDR4-3200**

Parameter	Symbol	Min	Max	Unit	
PPR programming time	$t^{\text{PGM}}$	x4, x8	1000	–	ms
		x16	2000	–	ms
PPR precharge exit time	$t^{\text{PGM\_Exit}}$	15	–	ns	
PPR exit time	$t^{\text{PGMPST}}$	50	–	$\mu\text{s}$	

## sPPR Row Repair

Soft post package repair (sPPR) is a way to quickly, but temporarily, repair a row element in a bank group (BG) on a DRAM device, where (hard) PPR takes longer but permanently repairs a row element. sPPR is disabled with MR4[5] = 0, which is the normal state, and sPPR is enabled with MR4[5] = 1, which is the sPPR enabled state.

The DRAM will retain the soft repair information as long as  $V_{\text{DD}}$  remains within the operating region unless rewritten by a subsequent sPPR entry to the same BG. If DRAM power is removed or the DRAM is reset, the soft repair will revert to the unrepaired state. PPR and sPPR may not be enabled at the same time. sPPR must have been disabled and cleared prior to entering PPR mode.

With sPPR, DDR4 can repair one row per bank group. When the hard PPR resources for a bank group are used up, the bank group has no more available resources for soft PPR. When a subsequent sPPR request is made to the same BG, the subsequently issued sPPR address will replace the previous sPPR address. If a repair sequence is issued to a bank group with no repair resource available, the DRAM will ignore the programming sequence.

All banks must be precharged and idle. DBI and CRC modes must be disabled, and all sPPR timings must be followed as shown in the timing diagram that follows.

All other commands except those listed in the following sequences are illegal.

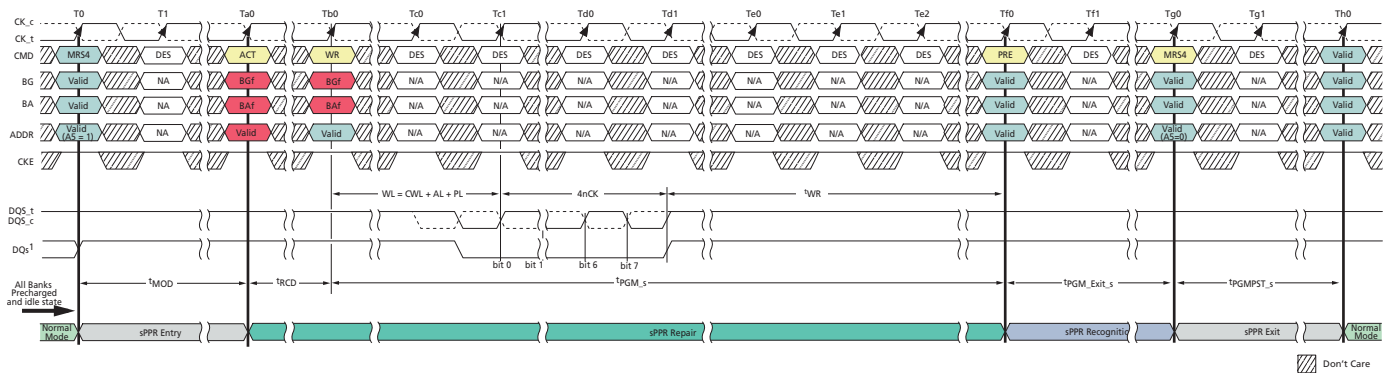
1. Issue MR4[5] 1 to enter sPPR mode enable.
  - a. All DQ are driven HIGH.
  - b. Note that the four guard key commands ARE NOT required for sPPR activation. That being said, JEDEC is may change this specification and require the same guard key as used PPR Mode. A prudent controller design should accommodate either option in case this DRAM is required to change.
2. After  $t^{\text{MOD}}$ , issue an ACT command with failing BG and BA with the row address to be repaired.
3. After  $t^{\text{RCD}}$ , issue a WR command with BG and BA of failing row address.
  - a. The address must be at valid levels, but the address is a "Don't Care."
4. All DQ of the target DRAM should be driven LOW for  $4n\text{CK}$  (bit 0 through bit 7) after WL (WL = CWL + AL + PL) in order for sPPR to initiate repair.
  - a. Repair **will be** initiated to the target DRAM only if all DQ during bit 0 through bit 7 are LOW.
  - b. Repair **will not be** initiated to the target DRAM if any DQ during bit 0 through bit 7 is HIGH.
    1. JEDEC states: All DQs of target DRAM should be LOW for  $4^t\text{CK}$ . If HIGH is driven to all DQs of a DRAM consecutively for equal to or longer than  $2^t\text{CK}$ , then DRAM does not conduct PPR and retains data if REF com-

- mand is properly issued; if all DQs are neither LOW for  $4^tCK$  nor HIGH for equal to or longer than  $2^tCK$ , then PPR mode execution is unknown.
- c. DQS should function normally.
5. REF command may NOT be issued at anytime while in sPPR mode.
  6. Issue PRE after  $^tWR$  time so that the device can repair the target row during  $^tWR$  time.
    - a. Wait  $^tPGM\_Exit\_s$  after PRE to allow the device to recognize the repaired target row address.
  7. Issue MR4[5] 0 command to sPPR mode disable.
    - a. Wait  $^tPGMPST\_s$  for sPPR mode exit to complete.
    - b. After  $^tPGMPST\_s$  has expired, any valid command may be issued.

The entire sequence from sPPR mode enable through sPPR mode disable may be repeated if more than one repair is to be done.

After sPPR mode has been exited, the DRAM controller can confirm if the target row was repaired correctly by writing data into the target row and reading it back.

**Figure 72: sPPR – Entry, Repair, and Exit**



**Table 41: DDR4 sPPR Timing Parameters DDR4-1600 through DDR4-3200**

Parameter	Symbol	Min	Max	Unit
sPPR programming time	$^tPGM\_s$	$^tRCD (MIN) + WL + 4nCK + ^tWR (MIN)$	–	ns
sPPR precharge exit time	$^tPGM\_Exit\_s$	20	–	ns
sPPR exit time	$^tPGMPST\_s$	$^tMOD$	–	ns

**PPR/sPPR Support Identifier**

**Table 42: DDR4 Repair Mode Support Identifier**

MPR Page 2	A7	A6	A5	A4	A3	A2	A1	A0
	UI0	UI1	UI2	UI3	UI4	UI5	UI6	UI7
MPRO	PPR <sup>1</sup>	sPPR <sup>2</sup>	R <sub>TT_WR</sub>	Temp sensor		CRC	R <sub>TT_WR</sub>	

- Notes: 1. 0 = PPR mode is not available, 1 = PPR mode is available.  
 2. 0 = sPPR mode is not available, 1 = sPPR mode is available.



## 4Gb: x4, x8, x16 DDR4 SDRAM Post Package Repair and Soft Post Package Repair

---

3. Gray shaded areas are for reference only.

## Target Row Refresh Mode

Rows can be accessed a limited number of times within a certain time period before adjacent rows require refresh. The maximum activate count (MAC) is the maximum number of activates that a single row can sustain within a time interval of equal to or less than the maximum activate window ( $t_{MAW}$ ) before the adjacent rows need to be refreshed, regardless of how the activates are distributed over  $t_{MAW}$ . The row receiving the excessive activates is the target row (TR $n$ ). The two adjacent rows to be refreshed are the victim rows. The MAC values are encoded in MPR Page 3 MPR3[4:0].

Target row refresh (TRR) mode is not required to be used, and in some cases has been rendered inoperable. Micron's DDR4 devices automatically perform TRR mode in the background. Most die will provide an MPR Page 3 MPR3[3:0] of 1000, indicating there is no restriction to the number of ACTIVATE commands to a given row in a refresh period provided DRAM timing specifications are not violated.

**Table 43: MAC Encoding of MPR Page 3 MPR3**

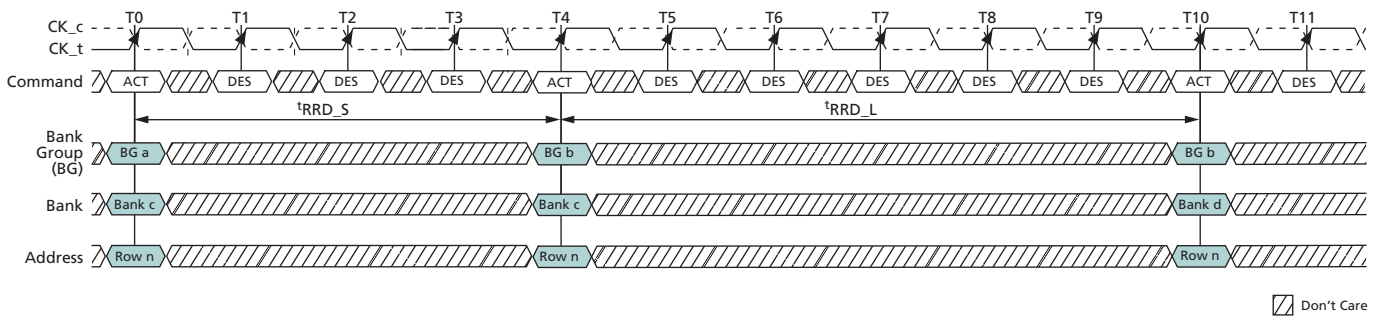
[7]	[6]	[5]	[4]	[3]	[2]	[1]	[0]	MAC	Comments
x	x	x	x	0	0	0	0	Untested	The device has not been tested for MAC.
x	x	x	x	0	0	0	1	$t_{MAC} = 700K$	
x	x	x	x	0	0	1	0	$t_{MAC} = 600K$	
x	x	x	x	0	0	1	1	$t_{MAC} = 500K$	
x	x	x	x	0	1	0	0	$t_{MAC} = 400K$	
x	x	x	x	0	1	0	1	$t_{MAC} = 300K$	
x	x	x	x	0	1	1	0	Reserved	
x	x	x	x	0	1	1	1	$t_{MAC} = 200K$	
x	x	x	x	1	0	0	0	Unlimited	There is no restriction to the number of ACTIVATE commands to a given row in a refresh period provided DRAM timing specifications are not violated.
x	x	x	x	1	0	0	1	Reserved	
x	x	x	x	:	:	:	:	Reserved	
x	x	x	x	1	1	1	1	Reserved	

Note: 1. MAC encoding in MPR Page 3 MPR3.

## ACTIVATE Command

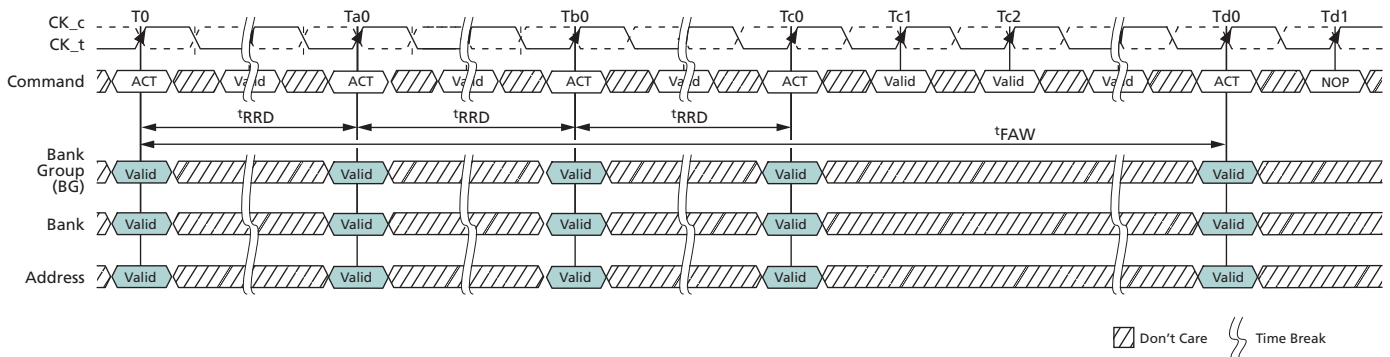
The ACTIVATE command is used to open (activate) a row in a particular bank for subsequent access. The values on the BG[1:0] inputs select the bank group, the BA[1:0] inputs select the bank within the bank group, and the address provided on inputs A[17:0] selects the row within the bank. This row remains active (open) for accesses until a PRECHARGE command is issued to that bank. A PRECHARGE command must be issued before opening a different row in the same bank. Bank-to-bank command timing for ACTIVATE commands uses two different timing parameters, depending on whether the banks are in the same or different bank group.  $t_{RRD\_S}$  (short) is used for timing between banks located in different bank groups.  $t_{RRD\_L}$  (long) is used for timing between banks located in the same bank group. Another timing restriction for consecutive ACTIVATE commands [issued at  $t_{RRD}$  (MIN)] is  $t_{FAW}$  (four activate windows). Because there is a maximum of four banks in a bank group, the  $t_{FAW}$  parameter applies across different bank groups (five ACTIVATE commands issued at  $t_{RRD\_L}$  (MIN) to the same bank group would be limited by  $t_{RC}$ ).

Figure 73:  $t_{RRD}$  Timing



- Notes:
1.  $t_{RRD\_S}$ ; ACTIVATE-to-ACTIVATE command period (short); applies to consecutive ACTIVATE commands to different bank groups (that is, T0 and T4).
  2.  $t_{RRD\_L}$ ; ACTIVATE-to-ACTIVATE command period (long); applies to consecutive ACTIVATE commands to the different banks in the same bank group (that is, T4 and T10).

Figure 74:  $t_{FAW}$  Timing



- Note:
1.  $t_{FAW}$ ; four activate windows.

## PRECHARGE Command

The PRECHARGE command is used to deactivate the open row in a particular bank or the open row in all banks. The bank(s) will be available for a subsequent row activation for a specified time ( $t_{RP}$ ) after the PRECHARGE command is issued. An exception to this is the case of concurrent auto precharge, where a READ or WRITE command to a different bank is allowed as long as it does not interrupt the data transfer in the current bank and does not violate any other timing parameters.

After a bank is precharged, it is in the idle state and must be activated prior to any READ or WRITE commands being issued to that bank. A PRECHARGE command is allowed if there is no open row in that bank (idle state) or if the previously open row is already in the process of precharging. However, the precharge period will be determined by the last PRECHARGE command issued to the bank.

The auto precharge feature is engaged when a READ or WRITE command is issued with A10 HIGH. The auto precharge feature uses the RAS lockout circuit to internally delay the PRECHARGE operation until the ARRAY RESTORE operation has completed. The RAS lockout circuit feature allows the PRECHARGE operation to be partially or completely hidden during burst READ cycles when the auto precharge feature is engaged. The PRECHARGE operation will not begin until after the last data of the burst write sequence is properly stored in the memory array.

## REFRESH Command

The REFRESH command (REF) is used during normal operation of the device. This command is nonpersistent, so it must be issued each time a refresh is required. The device requires REFRESH cycles at an average periodic interval of  $t_{REFI}$ . When CS<sub>n</sub>, RAS<sub>n</sub>/A16, and CAS<sub>n</sub>/A15 are held LOW and WE<sub>n</sub>/A14 HIGH at the rising edge of the clock, the device enters a REFRESH cycle. All banks of the SDRAM must be precharged and idle for a minimum of the precharge time,  $t_{RP}$  (MIN), before the REFRESH command can be applied. The refresh addressing is generated by the internal DRAM refresh controller. This makes the address bits “Don’t Care” during a REFRESH command. An internal address counter supplies the addresses during the REFRESH cycle. No control of the external address bus is required once this cycle has started. When the REFRESH cycle has completed, all banks of the SDRAM will be in the precharged (idle) state. A delay between the REFRESH command and the next valid command, except DES, must be greater than or equal to the minimum REFRESH cycle time  $t_{RFC}$  (MIN), as shown in Figure 75 (page 134).

**Note:** The  $t_{RFC}$  timing parameter depends on memory density.

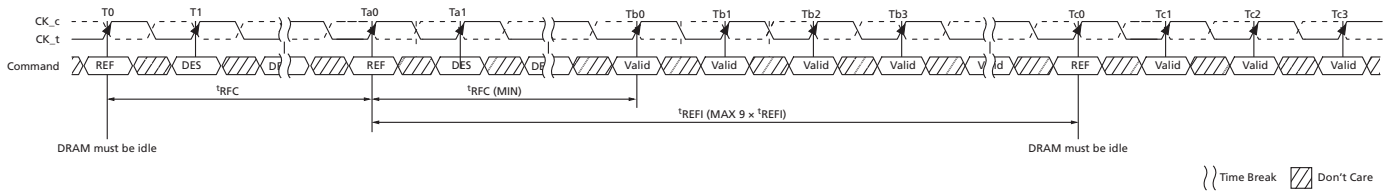
In general, a REFRESH command needs to be issued to the device regularly every  $t_{REFI}$  interval. To allow for improved efficiency in scheduling and switching between tasks, some flexibility in the absolute refresh interval is provided for postponing and pulling-in the REFRESH command. A limited number REFRESH commands can be postponed depending on refresh mode: a maximum of 8 REFRESH commands can be postponed when the device is in 1X refresh mode; a maximum of 16 REFRESH commands can be postponed when the device is in 2X refresh mode; and a maximum of 32 REFRESH commands can be postponed when the device is in 4X refresh mode.

When 8 consecutive REFRESH commands are postponed, the resulting maximum interval between the surrounding REFRESH commands is limited to  $9 \times t_{REFI}$  (see Figure 76

(page 134)). For both the 2X and 4X refresh modes, the maximum consecutive REFRESH commands allowed is limited to  $17 \times t_{REFI2}$  and  $36 \times t_{REFI4}$ , respectively.

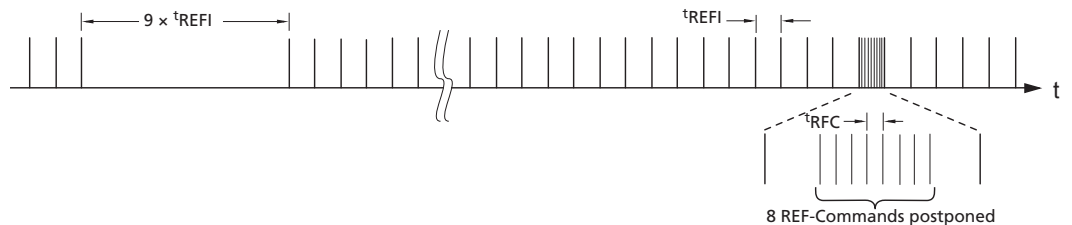
A limited number REFRESH commands can be pulled-in as well. A maximum of 8 additional REFRESH commands can be issued in advance or “pulled-in” in 1X refresh mode, a maximum of 16 additional REFRESH commands can be issued when in advance in 2X refresh mode, and a maximum of 32 additional REFRESH commands can be issued in advance when in 4X refresh mode. Each of these REFRESH commands reduces the number of regular REFRESH commands required later by one. Note that pulling in more than the maximum allowed REFRESH commands in advance does not further reduce the number of regular REFRESH commands required later, so that the resulting maximum interval between two surrounding REFRESH commands is limited to  $9 \times t_{REFI}$  (Figure 77 (page 134)),  $18 \times t_{REFI2}$ , or  $36 \times t_{REFI4}$ . At any given time, a maximum of 16 REF commands can be issued within  $2 \times t_{REF}$ , 32 REF2 commands can be issued within  $4 \times t_{REF}$ , and 64 REF4 commands can be issued within  $8 \times t_{REFI4}$ .

**Figure 75: REFRESH Command Timing**

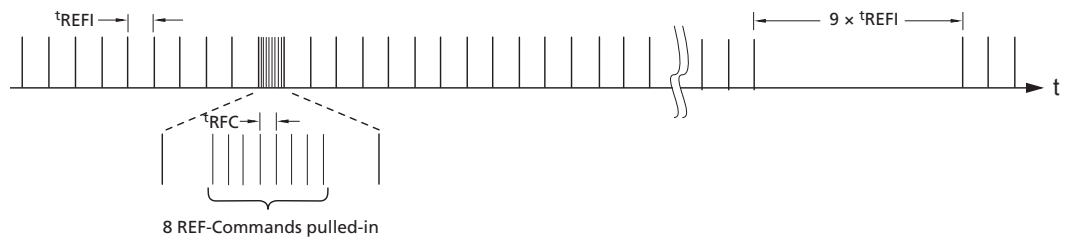


- Notes:
1. Only DES commands are allowed after a REFRESH command is registered until  $t_{RFC}$  (MIN) expires.
  2. Time interval between two REFRESH commands may be extended to a maximum of  $9 \times t_{REFI}$ .

**Figure 76: Postponing REFRESH Commands (Example)**



**Figure 77: Pulling In REFRESH Commands (Example)**



## Temperature-Controlled Refresh Mode

During normal operation, temperature-controlled refresh (TCR) mode disabled, the device must have a REFRESH command issued once every  $t_{REFI}$ , except for what is allowed by posting (see REFRESH Command section). This means a REFRESH command must be issued once every  $3.9\mu s$  if  $T_C$  is greater than or equal to  $85^\circ C$ , and once every  $7.8\mu s$  if  $T_C$  is less than  $85^\circ C$ .

**Table 44: Normal  $t_{REFI}$  Refresh (TCR Disabled)**

Temperature	Normal Temperature		Extended Temperature	
	External Refresh Period	Internal Refresh Period	External Refresh Period	Internal Refresh Period
$T_C < 45^\circ C$	7.8 $\mu s$	7.8 $\mu s$	3.9 $\mu s$ <sup>1</sup>	3.9 $\mu s$ <sup>1</sup>
$45^\circ C \leq T_C < 85^\circ C$				
$85^\circ C \leq T_C < 95^\circ C$	N/A			

Note: 1. If  $T_C$  is less than  $85^\circ C$ , the external refresh period can be  $7.8\mu s$  instead of  $3.9\mu s$ .

When TCR mode is enabled, the device will register the externally supplied REFRESH command and adjust the internal refresh period to be longer than  $t_{REFI}$  of the normal temperature range, when allowed, by skipping REFRESH commands with the proper gear ratio. TCR mode has two ranges to select between the normal temperature range and the extended temperature range; the correct range must be selected so the internal control operates correctly. The DRAM must have the correct refresh rate applied externally; the internal refresh rate is determined by the DRAM based upon the temperature.

### TCR Mode – Normal Temperature Range

REFRESH commands should be issued to the device with the refresh period equal to or shorter than  $t_{REFI}$  of normal temperature range ( $0^\circ C$  to  $85^\circ C$ ). In this mode, the system guarantees that the temperature does not exceed  $85^\circ C$ . The device may adjust the internal refresh period to be longer than  $t_{REFI}$  of the normal temperature range by skipping external REFRESH commands with the proper gear ratio when  $T_C$  is below  $45^\circ C$ . The internal refresh period is automatically adjusted inside the DRAM, and the DRAM controller does not need to provide any additional control.

### TCR Mode – Extended Temperature Range

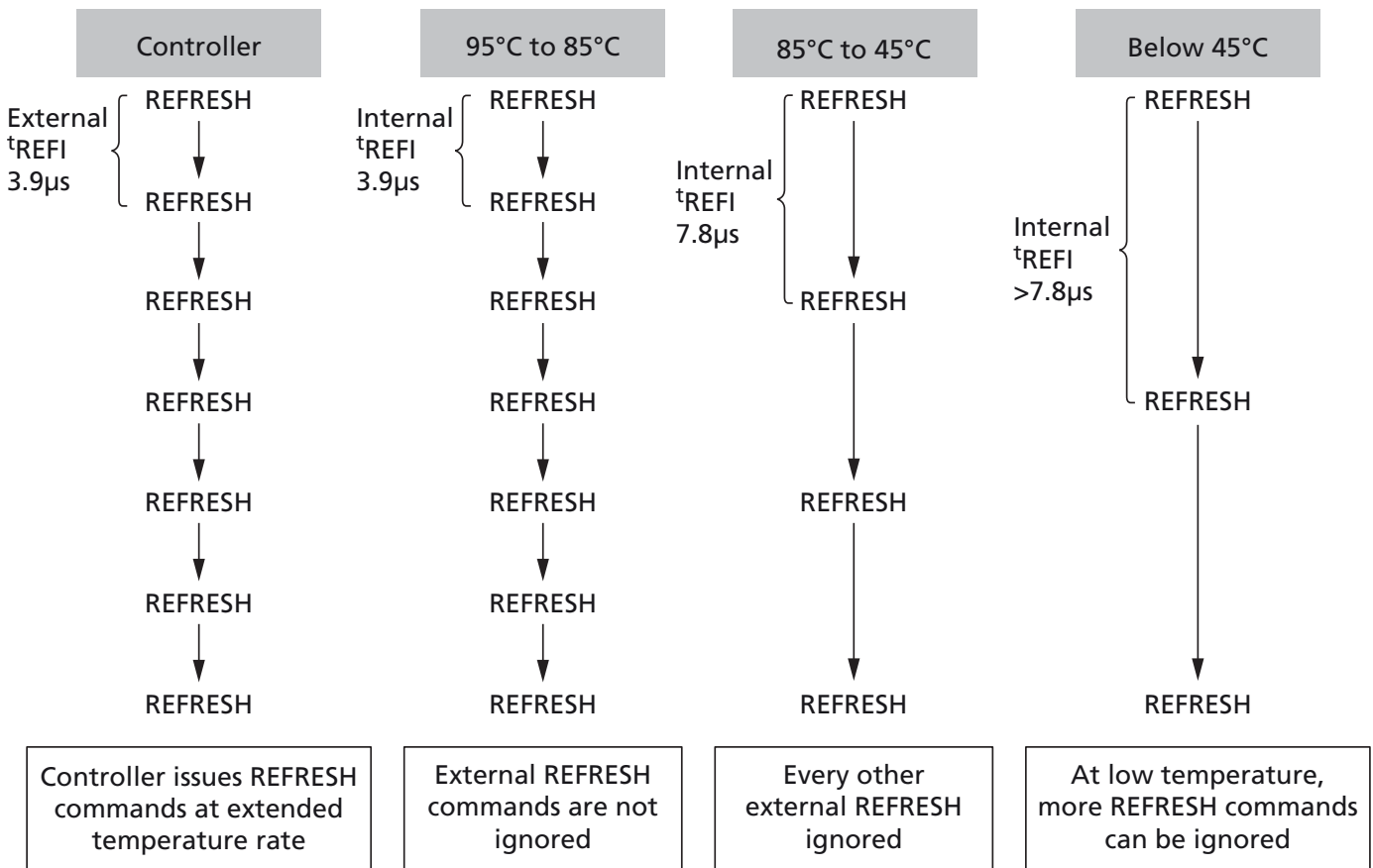
REFRESH commands should be issued to the device with the refresh period equal to or shorter than  $t_{REFI}$  of extended temperature range ( $85^\circ C$  to  $95^\circ C$ ). Even though the external refresh supports the extended temperature range, the device will adjust its internal refresh period to  $t_{REFI}$  of the normal temperature range by skipping external REFRESH commands with proper gear ratio when operating in the normal temperature range ( $0^\circ C$  to  $85^\circ C$ ). The device may adjust the internal refresh period to be longer than  $t_{REFI}$  of the normal temperature range by skipping external REFRESH commands with the proper gear ratio when  $T_C$  is below  $45^\circ C$ . The internal refresh period is automatically adjusted inside the DRAM, and the DRAM controller does not need to provide any additional control.

**Table 45: Normal  $t_{REFI}$  Refresh (TCR Enabled)**

Temperature	Normal Temperature Range		Extended Temperature Range	
	External Refresh Period	Internal Refresh Period	External Refresh Period	Internal Refresh Period
$T_C < 45^\circ\text{C}$	7.8 $\mu\text{s}$	$\gg 7.8\mu\text{s}$	3.9 $\mu\text{s}$ <sup>1</sup>	$\gg 7.8\mu\text{s}$
$45^\circ\text{C} \leq T_C < 85^\circ\text{C}$	7.8 $\mu\text{s}$	7.8 $\mu\text{s}$		7.8 $\mu\text{s}$
$85^\circ\text{C} \leq T_C < 95^\circ\text{C}$	N/A			3.9 $\mu\text{s}$

Note: 1. If the external refresh period is 7.8 $\mu\text{s}$ , the device will refresh internally at half the listed refresh rate and will violate refresh specifications.

**Figure 78: TCR Mode Example<sup>1</sup>**



Note: 1. TCR enabled with extended temperature range selected.

## Fine Granularity Refresh Mode

### Mode Register and Command Truth Table

The REFRESH cycle time ( $t_{RFC}$ ) and the average refresh interval ( $t_{REFI}$ ) can be programmed by the MRS command. The appropriate setting in the mode register will set a single set of REFRESH cycle times and average refresh interval for the device (fixed mode), or allow the dynamic selection of one of two sets of REFRESH cycle times and average refresh interval for the device (on-the-fly mode [OTF]). OTF mode must be enabled by MRS before any OTF REFRESH command can be issued.

**Table 46: MRS Definition**

MR3[8]	MR3[7]	MR3[6]	Refresh Rate Mode
0	0	0	Normal mode (fixed 1x)
0	0	1	Fixed 2x
0	1	0	Fixed 4x
0	1	1	Reserved
1	0	0	Reserved
1	0	1	On-the-fly 1x/2x
1	1	0	On-the-fly 1x/4x
1	1	1	Reserved

There are two types of OTF modes (1x/2x and 1x/4x modes) that are selectable by programming the appropriate values into the mode register. When either of the two OTF modes is selected, the device evaluates the BG0 bit when a REFRESH command is issued, and depending on the status of BG0, it dynamically switches its internal refresh configuration between 1x and 2x (or 1x and 4x) modes, and then executes the corresponding REFRESH operation.

**Table 47: REFRESH Command Truth Table**

Refresh	CS_n	ACT_n	RAS_n/A 15	CAS_n/A 14	WE_n/ A13	BG1	BG0	A10/ AP	A[9:0], A[12:11], A[20:16]	MR3[8:6 ]
Fixed rate	L	H	L	L	H	V	V	V	V	0vv
OTF: 1x	L	H	L	L	H	V	L	V	V	1vv
OTF: 2x	L	H	L	L	H	V	H	V	V	101
OTF: 4x	L	H	L	L	H	V	H	V	V	110

### $t_{REFI}$ and $t_{RFC}$ Parameters

The default refresh rate mode is fixed 1x mode where REFRESH commands should be issued with the normal rate; that is,  $t_{REFI1} = t_{REFI}(\text{base})$  (for  $T_C \leq 85^\circ\text{C}$ ), and the duration of each REFRESH command is the normal REFRESH cycle time ( $t_{RFC1}$ ). In 2x mode (either fixed 2x or OTF 2x mode), REFRESH commands should be issued to the device at the double frequency ( $t_{REFI2} = t_{REFI}(\text{base})/2$ ) of the normal refresh rate. In 4x mode, the REFRESH command rate should be quadrupled ( $t_{REFI4} = t_{REFI}(\text{base})/4$ ). Per

each mode and command type, the  $t_{RFC}$  parameter has different values as defined in the following table.

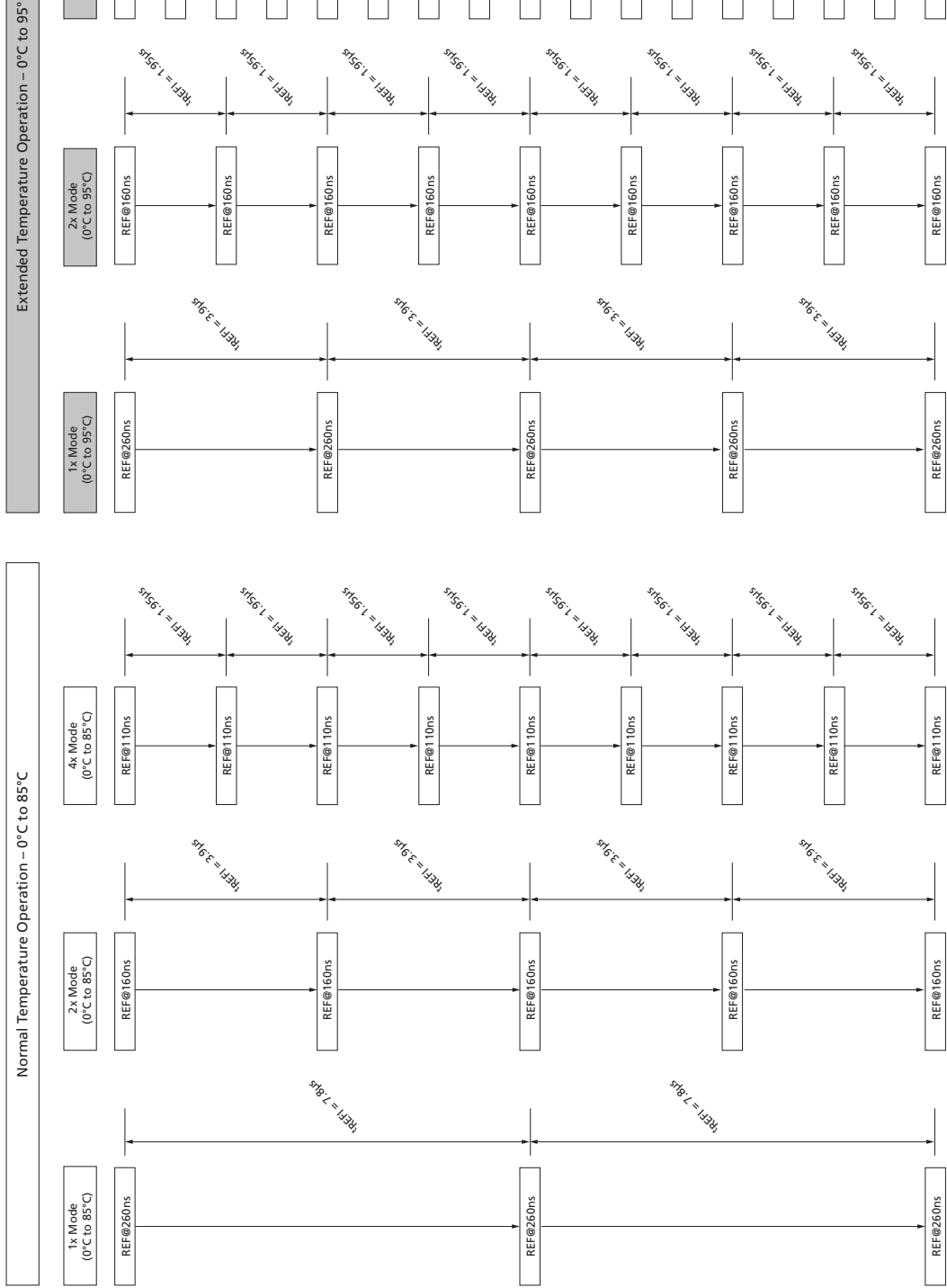
For discussion purposes, the REFRESH command that should be issued at the normal refresh rate and has the normal REFRESH cycle duration may be referred to as a REF1x command. The REFRESH command that should be issued at the double frequency ( $t_{REFI2} = t_{REFI(base)}/2$ ) may be referred to as a REF2x command. Finally, the REFRESH command that should be issued at the quadruple rate ( $t_{REFI4} = t_{REFI(base)}/4$ ) may be referred to as a REF4x command.

In the fixed 1x refresh rate mode, only REF1x commands are permitted. In the fixed 2x refresh rate mode, only REF2x commands are permitted. In the fixed 4x refresh rate mode, only REF4x commands are permitted. When the on-the-fly 1x/2x refresh rate mode is enabled, both REF1x and REF2x commands are permitted. When the OTF 1x/4x refresh rate mode is enabled, both REF1x and REF4x commands are permitted.

**Table 48:  $t_{REFI}$  and  $t_{RFC}$  Parameters**

Refresh Mode	Parameter		2Gb	4Gb	8Gb	16Gb	Units
	$t_{REFI}$ (base)		7.8	7.8	7.8	TBD	$\mu s$
1x mode	$t_{REFI1}$	$0^{\circ}C \leq T_C \leq 85^{\circ}C$	$t_{REFI(base)}$	$t_{REFI(base)}$	$t_{REFI(base)}$	$t_{REFI(base)}$	$\mu s$
		$85^{\circ}C \leq T_C \leq 95^{\circ}C$	$t_{REFI(base)}/2$	$t_{REFI(base)}/2$	$t_{REFI(base)}/2$	$t_{REFI(base)}/2$	$\mu s$
	$t_{RFC1}$		160	260	350	TBD	ns
2x mode	$t_{REFI2}$	$0^{\circ}C \leq T_C \leq 85^{\circ}C$	$t_{REFI(base)}/2$	$t_{REFI(base)}/2$	$t_{REFI(base)}/2$	$t_{REFI(base)}/2$	$\mu s$
		$85^{\circ}C \leq T_C \leq 95^{\circ}C$	$t_{REFI(base)}/4$	$t_{REFI(base)}/4$	$t_{REFI(base)}/4$	$t_{REFI(base)}/4$	$\mu s$
	$t_{RFC2}$		110	160	260	TBD	ns
4x mode	$t_{REFI4}$	$0^{\circ}C \leq T_C \leq 85^{\circ}C$	$t_{REFI(base)}/4$	$t_{REFI(base)}/4$	$t_{REFI(base)}/4$	$t_{REFI(base)}/4$	$\mu s$
		$85^{\circ}C \leq T_C \leq 95^{\circ}C$	$t_{REFI(base)}/8$	$t_{REFI(base)}/8$	$t_{REFI(base)}/8$	$t_{REFI(base)}/8$	$\mu s$
	$t_{RFC4}$		90	110	160	TBD	ns

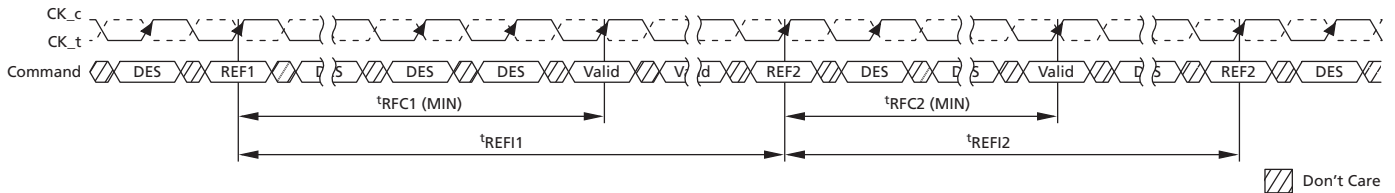
**Figure 79: 4Gb with Fine Granularity Refresh Mode Example**



## Changing Refresh Rate

If the refresh rate is changed by either MRS or OTF. New  $t_{REF1}$  and  $t_{RFC}$  parameters will be applied from the moment of the rate change. When the REF1x command is issued to the DRAM,  $t_{REF1}$  and  $t_{RFC1}$  are applied from the time that the command was issued; when the REF2x command is issued,  $t_{REF2}$  and  $t_{RFC2}$  should be satisfied.

**Figure 80: OTF REFRESH Command Timing**



The following conditions must be satisfied before the refresh rate can be changed. Otherwise, data retention cannot be guaranteed.

- In the fixed 2x refresh rate mode or the OTF 1x/2x refresh mode, an even number of REF2x commands must be issued because the last change of the refresh rate mode with an MRS command before the refresh rate can be changed by another MRS command.
- In the OTF 1x/2x refresh rate mode, an even number of REF2x commands must be issued between any two REF1x commands.
- In the fixed 4x refresh rate mode or the OTF 1x/4x refresh mode, a multiple-of-four number of REF4x commands must be issued because the last change of the refresh rate with an MRS command before the refresh rate can be changed by another MRS command.
- In the OTF 1x/4x refresh rate mode, a multiple-of-four number of REF4x commands must be issued between any two REF1x commands.

There are no special restrictions for the fixed 1x refresh rate mode. Switching between fixed and OTF modes keeping the same rate is not regarded as a refresh rate change.

## Usage with TCR Mode

If the temperature controlled refresh mode is enabled, only the normal mode (fixed 1x mode, MR3[8:6] = 000) is allowed. If any other refresh mode than the normal mode is selected, the temperature controlled refresh mode must be disabled.

## Self Refresh Entry and Exit

The device can enter self refresh mode anytime in 1x, 2x, and 4x mode without any restriction on the number of REFRESH commands that have been issued during the mode before the self refresh entry. However, upon self refresh exit, extra REFRESH command(s) may be required, depending on the condition of the self refresh entry.

The conditions and requirements for the extra REFRESH command(s) are defined as follows:

- In the fixed 2x refresh rate mode or the enable-OTF 1x/2x refresh rate mode, it is recommended there be an even number of REF2x commands before entry into self refresh after the last self refresh exit, REF1x command, or MRS command that set the

refresh mode. If this condition is met, no additional REFRESH commands are required upon self refresh exit. In the case that this condition is not met, either one extra REF1x command or two extra REF2x commands must be issued upon self refresh exit. These extra REFRESH commands are not counted toward the computation of the average refresh interval (<sup>t</sup>REFI).

- In the fixed 4x refresh rate mode or the enable-OTF 1x/4x refresh rate mode, it is recommended there be a multiple-of-four number of REF4x commands before entry into self refresh after the last self refresh exit, REF1x command, or MRS command that set the refresh mode. If this condition is met, no additional refresh commands are required upon self refresh exit. When this condition is not met, either one extra REF1x command or four extra REF4x commands must be issued upon self refresh exit. These extra REFRESH commands are not counted toward the computation of the average refresh interval (<sup>t</sup>REFI).

There are no special restrictions on the fixed 1x refresh rate mode.

This section does not change the requirement regarding postponed REFRESH commands. The requirement for the additional REFRESH command(s) described above is independent of the requirement for the postponed REFRESH commands.

## SELF REFRESH Operation

The SELF REFRESH command can be used to retain data in the device, even if the rest of the system is powered down. When in self refresh mode, the device retains data without external clocking. The device has a built-in timer to accommodate SELF REFRESH operation. The SELF REFRESH command is defined by having CS<sub>n</sub>, RAS<sub>n</sub>, CAS<sub>n</sub>, and CKE held LOW with WE<sub>n</sub> and ACT<sub>n</sub> HIGH at the rising edge of the clock.

Before issuing the SELF REFRESH ENTRY command, the device must be idle with all banks in the precharge state and <sup>t</sup>RP satisfied. Idle state is defined as: All banks are closed (<sup>t</sup>RP, <sup>t</sup>DAL, and so on, satisfied), no data bursts are in progress, CKE is HIGH, and all timings from previous operations are satisfied (<sup>t</sup>MRD, <sup>t</sup>MOD, <sup>t</sup>RFC, <sup>t</sup>ZQinit, <sup>t</sup>ZQoper, <sup>t</sup>ZQCS, and so on). After the SELF REFRESH ENTRY command is registered, CKE must be held LOW to keep the device in self refresh mode. The DRAM automatically disables ODT termination, regardless of the ODT pin, when it enters self refresh mode and automatically enables ODT upon exiting self refresh. During normal operation (DLL<sub>on</sub>), the DLL is automatically disabled upon entering self refresh and is automatically enabled (including a DLL reset) upon exiting self refresh.

When the device has entered self refresh mode, all of the external control signals, except CKE and RESET<sub>n</sub>, are “Don’t Care.” For proper SELF REFRESH operation, all power supply and reference pins (V<sub>DD</sub>, V<sub>DDQ</sub>, V<sub>SS</sub>, V<sub>SSQ</sub>, V<sub>PP</sub>, and V<sub>REFCA</sub>) must be at valid levels. The DRAM internal V<sub>REFDQ</sub> generator circuitry may remain on or be turned off depending on the MR<sub>x</sub> bit Y setting. If the internal V<sub>REFDQ</sub> circuit is on in self refresh, the first WRITE operation or first write-leveling activity may occur after <sup>t</sup>XS time after self refresh exit. If the DRAM internal V<sub>REFDQ</sub> circuitry is turned off in self refresh, it ensures that the V<sub>REFDQ</sub> generator circuitry is powered up and stable within the <sup>t</sup>XSDLL period when the DRAM exits the self refresh state. The first WRITE operation or first write-leveling activity may not occur earlier than <sup>t</sup>XSDLL after exiting self refresh. The device initiates a minimum of one REFRESH command internally within the <sup>t</sup>CKE period once it enters self refresh mode.

The clock is internally disabled during a SELF REFRESH operation to save power. The minimum time that the device must remain in self refresh mode is <sup>t</sup>CKESR/<sup>t</sup>CKESR<sub>PAR</sub>. The user may change the external clock frequency or halt the external clock <sup>t</sup>CKSRE/<sup>t</sup>CKSRE<sub>PAR</sub> after self refresh entry is registered; however, the clock must be restarted and <sup>t</sup>CKSRX must be stable before the device can exit SELF REFRESH operation.

The procedure for exiting self refresh requires a sequence of events. First, the clock must be stable prior to CKE going back HIGH. Once a SELF REFRESH EXIT command (SRX, combination of CKE going HIGH and DESELECT on the command bus) is registered, the following timing delay must be satisfied:

Commands that do not require locked DLL:

- <sup>t</sup>XS = ACT, PRE, PREA, REF, SRE, and PDE.
- <sup>t</sup>XS<sub>FAST</sub> = ZQCL, ZQCS, and MRS commands. For an MRS command, only DRAM CL, WR/RTP register, and DLL reset in MR0; R<sub>TT(NOM)</sub> register in MR1; the CWL and R<sub>TT(WR)</sub> registers in MR2; and gear-down mode register in MR3; WRITE and READ preamble registers in MR4; R<sub>TT(PARK)</sub> register in MR5; <sup>t</sup>CCD<sub>L</sub>/<sup>t</sup>DLLK and V<sub>REFDQ</sub> calibration value registers in MR6 may be accessed provided the DRAM is not in per-DRAM mode. Access to other DRAM mode registers must satisfy <sup>t</sup>XS timing. WRITE commands (WR, WRS4, WRS8, WRA, WRAS4, and WRAS8) that require synchronous ODT and dynamic ODT controlled by the WRITE command require a locked DLL.

Commands that require locked DLL in the normal operating range:

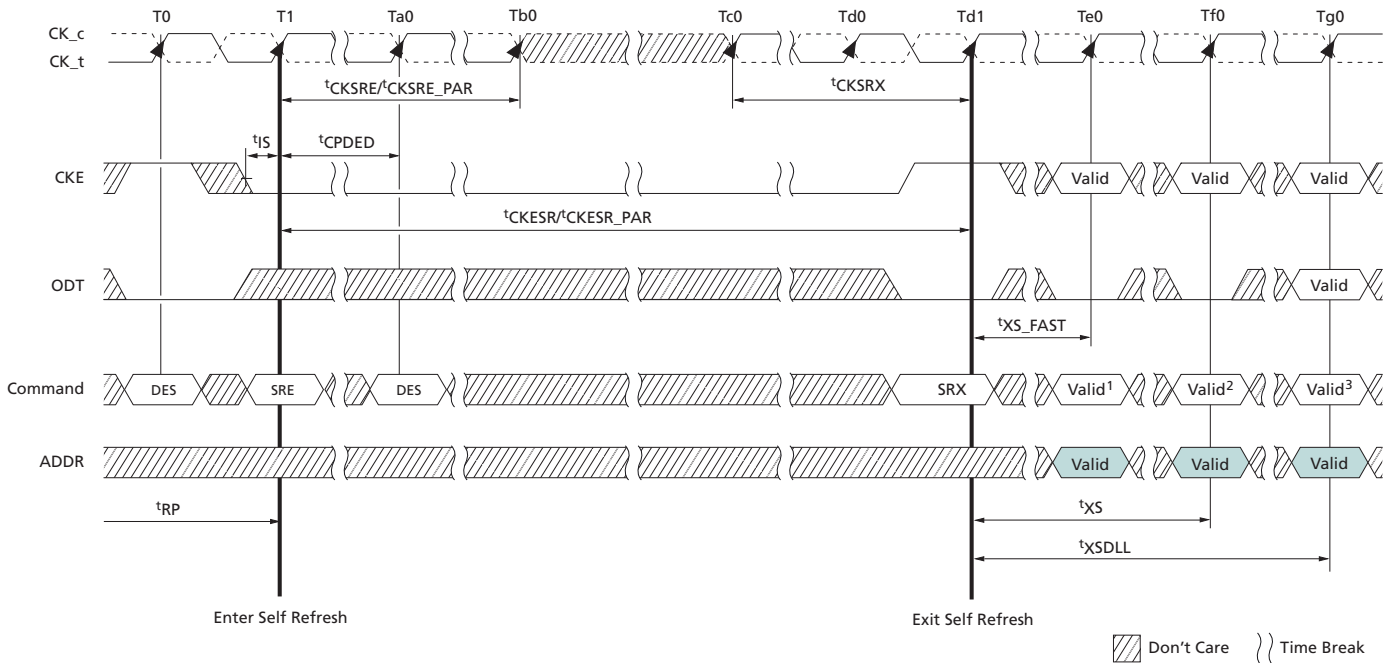
- $t_{XSDLL}$  – RD, RDS4, RDS8, RDA, RDAS4, and RDAS8 (unlike DDR3, WR, WRS4, WRS8, WRA, WRAS4, and WRAS8 because synchronous ODT is required).

Depending on the system environment and the amount of time spent in self refresh, ZQ CALIBRATION commands may be required to compensate for the voltage and temperature drift described in the ZQ CALIBRATION Commands section. To issue ZQ CALIBRATION commands, applicable timing requirements must be satisfied (see the ZQ Calibration Timing figure).

CKE must remain HIGH for the entire self refresh exit period  $t_{XSDLL}$  for proper operation except for self refresh re-entry. Upon exit from self refresh, the device can be put back into self refresh mode or power-down mode after waiting at least  $t_{XS}$  period and issuing one REFRESH command (refresh period of  $t_{RFC}$ ). The DESELECT command must be registered on each positive clock edge during the self refresh exit interval  $t_{XS}$ . ODT must be turned off during  $t_{XSDLL}$ .

The use of self refresh mode introduces the possibility that an internally timed refresh event can be missed when CKE is raised for exit from self refresh mode. Upon exit from self refresh, the device requires a minimum of one extra REFRESH command before it is put back into self refresh mode.

**Figure 81: Self Refresh Entry/Exit Timing**



- Notes:
1. Only MRS (limited to those described in the SELF REFRESH Operation section), ZQCS, or ZQCL commands are allowed.
  2. Valid commands not requiring a locked DLL.
  3. Valid commands requiring a locked DLL.

**Figure 82: Self Refresh Entry/Exit Timing with CAL Mode**

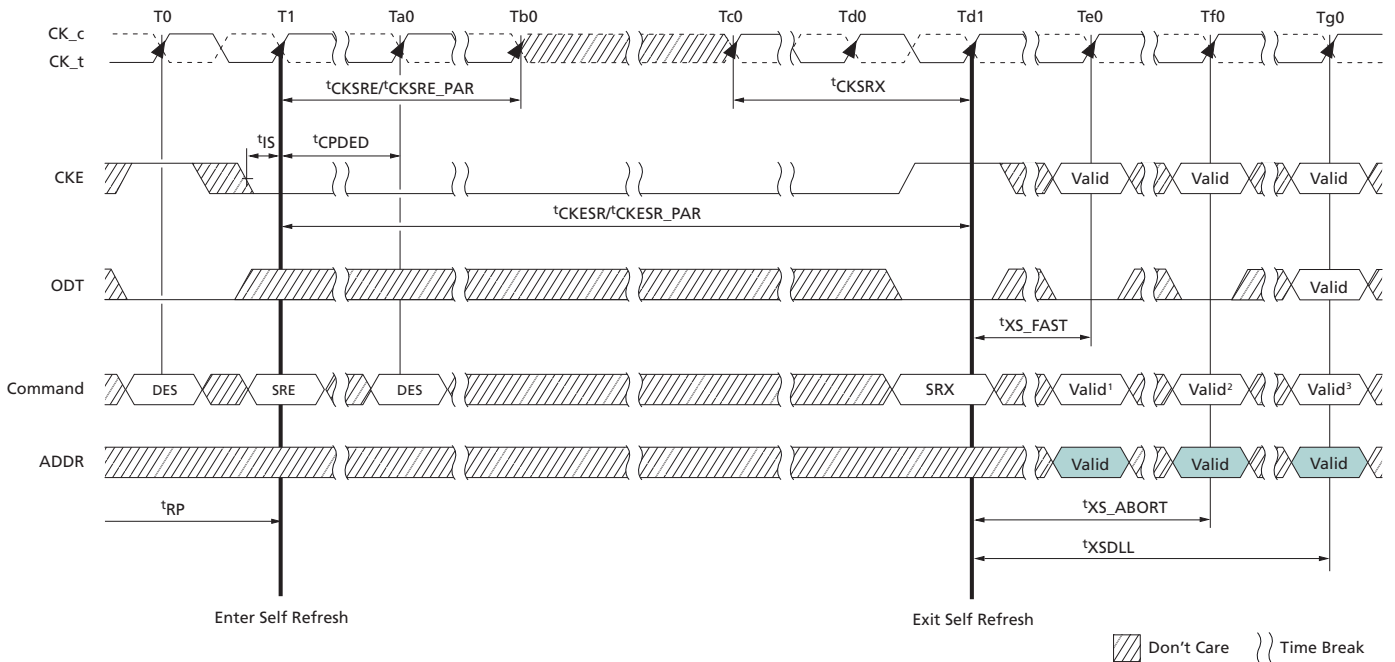
Reserved For Figure

- Notes:
1.  $t_{CAL} = 3nCK$ ,  $t_{CPDED} = 4nCK$ ,  $t_{CKSRE}/t_{CKSRE\_PAR} = 8nCK$ ,  $t_{CKSRX} = 8nCK$ ,  $t_{XS\_FAST} = t_{REFC4} (MIN) + 10ns$ .
  2. CS\_n = HIGH, ACT\_n = "Don't Care," RAS\_n/A16 = "Don't Care," CAS\_n/A15 = "Don't Care," WE\_n/A14 = "Don't Care."
  3. Only MRS (limited to those described in the SELF REFRESH Operations section), ZQCS, or ZQCL commands are allowed.

## Self Refresh Abort

The exit timing from self refresh exit to the first valid command not requiring a locked DLL is  $t_{XS}$ . The value of  $t_{XS}$  is ( $t_{RFC} + 10ns$ ). This delay allows any refreshes started by the device time to complete.  $t_{RFC}$  continues to grow with higher density devices, so  $t_{XS}$  will grow as well. An MRS bit enables the self refresh abort mode. If the bit is disabled, the controller uses  $t_{XS}$  timings (location MR4, bit 9). If the bit is enabled, the device aborts any ongoing refresh and does not increment the refresh counter. The controller can issue a valid command not requiring a locked DLL after a delay of  $t_{XS\_ABORT}$ . Upon exit from self refresh, the device requires a minimum of one extra REFRESH command before it is put back into self refresh mode. This requirement remains the same irrespective of the setting of the MRS bit for self refresh abort.

**Figure 83: Self Refresh Abort**



- Notes:
1. Only MRS (limited to those described in the SELF REFRESH Operation section), ZQCS, or ZQCL commands are allowed.
  2. Valid commands not requiring a locked DLL with self refresh abort mode enabled in the mode register.
  3. Valid commands requiring a locked DLL.

### Self Refresh Exit with NOP Command

Exiting self refresh mode using the NO OPERATION command (NOP) is allowed under a specific system application. This special use of NOP allows for a common command/address bus between active DRAM devices and DRAM(s) in maximum power saving mode. Self refresh mode may exit with NOP commands provided:

- The device entered self refresh mode with CA parity and CAL disabled.
- $t_{MPX\_S}$  and  $t_{MPX\_LH}$  are satisfied.
- NOP commands are only issued during  $t_{MPX\_LH}$  window.

No other command is allowed during the  $t_{MPX\_LH}$  window after an SELF REFRESH EXIT (SRX) command is issued.

**Figure 84: Self Refresh Exit with NOP Command**

Reserved For Figure

## Power-Down Mode

Power-down is synchronously entered when CKE is registered LOW (along with a DESELECT command). CKE is not allowed to go LOW when the following operations are in progress: MRS command, MPR operations, ZQCAL operations, DLL locking, or READ/WRITE operations. CKE is allowed to go LOW while any other operations, such as ROW ACTIVATION, PRECHARGE or auto precharge, or REFRESH, are in progress, but the power-down  $I_{DD}$  specification will not be applied until those operations are complete. The timing diagrams that follow illustrate power-down entry and exit.

For the fastest power-down exit timing, the DLL should be in a locked state when power-down is entered. If the DLL is not locked during power-down entry, the DLL must be reset after exiting power-down mode for proper READ operation and synchronous ODT operation. DRAM design provides all AC and DC timing and voltage specification as well as proper DLL operation with any CKE intensive operations as long as the controller complies with DRAM specifications.

During power-down, if all banks are closed after any in-progress commands are completed, the device will be in precharge power-down mode; if any bank is open after in-progress commands are completed, the device will be in active power-down mode.

Entering power-down deactivates the input and output buffers, excluding CK, CKE, and RESET\_n. In power-down mode, DRAM ODT input buffer deactivation is based on MRx bit Y. If it is configured to 0b, the ODT input buffer remains on and the ODT input signal must be at valid logic level. If it is configured to 1b, the ODT input buffer is deactivated and the DRAM ODT input signal may be floating and the device does not provide  $R_{TT(NOM)}$  termination. Note that the device continues to provide  $R_{TT(Park)}$  termination if it is enabled in the mode register MRa bit B. To protect internal delay on the CKE line to block the input signals, multiple DES commands are needed during the CKE switch off and on cycle(s); this timing period is defined as  $t_{CPDED}$ . CKE LOW will result in deactivation of command and address receivers after  $t_{CPDED}$  has expired.

**Table 49: Power-Down Entry Definitions**

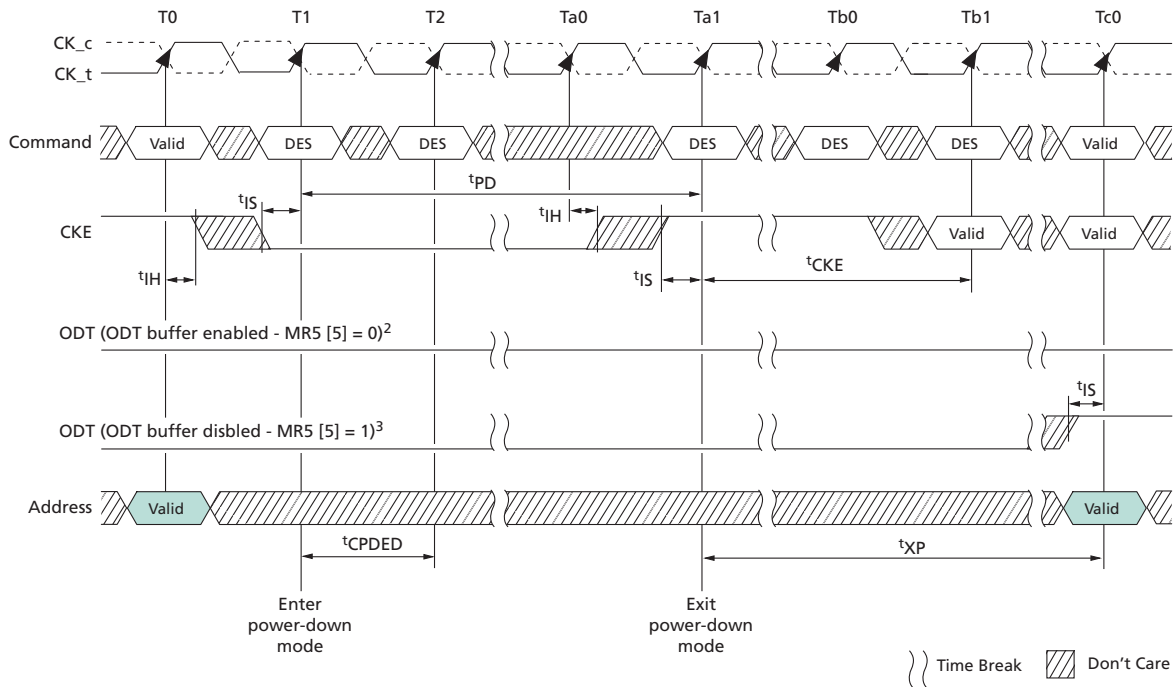
DRAM Status	DLL	Power-Down Exit	Relevant Parameters
Active (a bank or more open)	On	Fast	$t_{XP}$ to any valid command.
Precharged (all banks precharged)	On	Fast	$t_{XP}$ to any valid command.

The DLL is kept enabled during precharge power-down or active power-down. In power-down mode, CKE is LOW, RESET\_n is HIGH, and a stable clock signal must be maintained at the inputs of the device. ODT should be in a valid state, but all other input signals are "Don't Care." (If RESET\_n goes LOW during power-down, the device will be out of power-down mode and in the reset state.) CKE LOW must be maintained until  $t_{CKE}$  has been satisfied. Power-down duration is limited by  $9 \times t_{REFI}$ .

The power-down state is synchronously exited when CKE is registered HIGH (along with DES command). CKE HIGH must be maintained until  $t_{CKE}$  has been satisfied. The ODT input signal must be at a valid level when the device exits from power-down mode, independent of MRx bit Y if  $R_{TT(NOM)}$  is enabled in the mode register. If  $R_{TT(NOM)}$  is disabled, the ODT input signal may remain floating. A valid, executable command can be

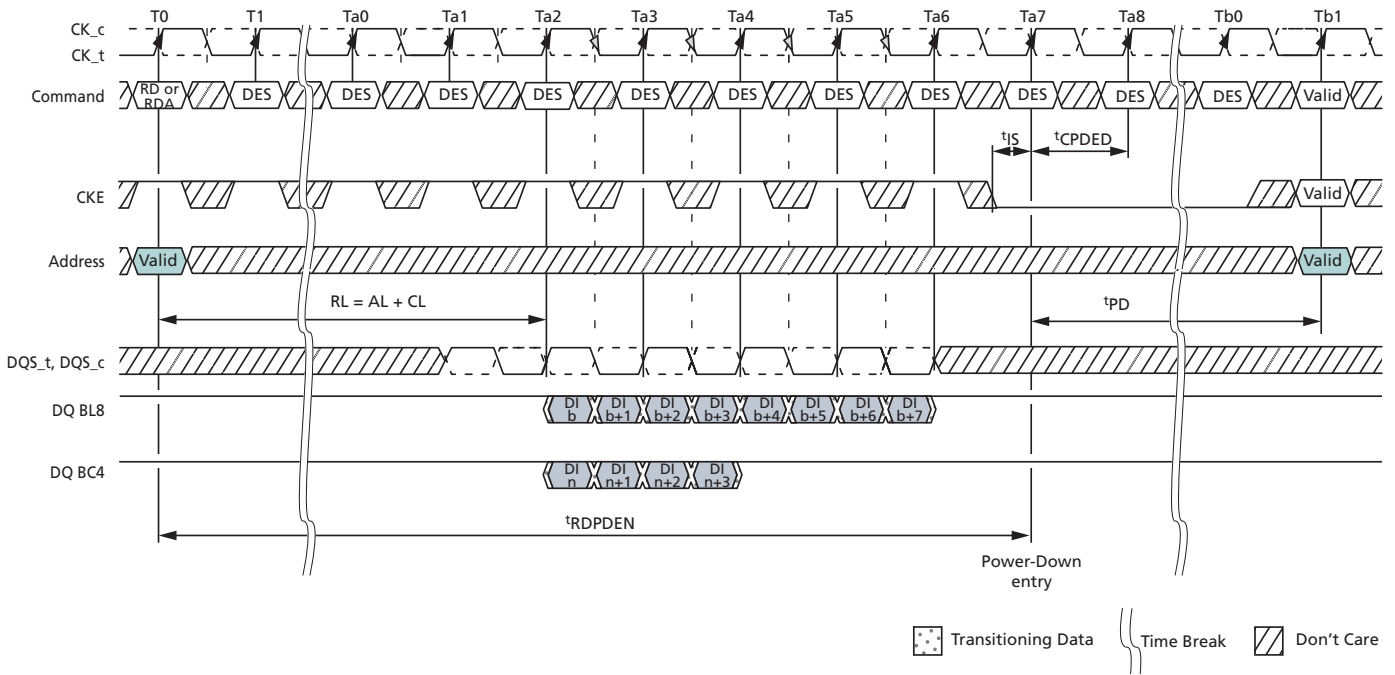
applied with power-down exit latency,  $t_{XP}$ , and/or  $t_{XPDLL}$  after CKE goes HIGH. Power-down exit latency is defined in the AC Specifications table.

**Figure 85: Active Power-Down Entry and Exit**



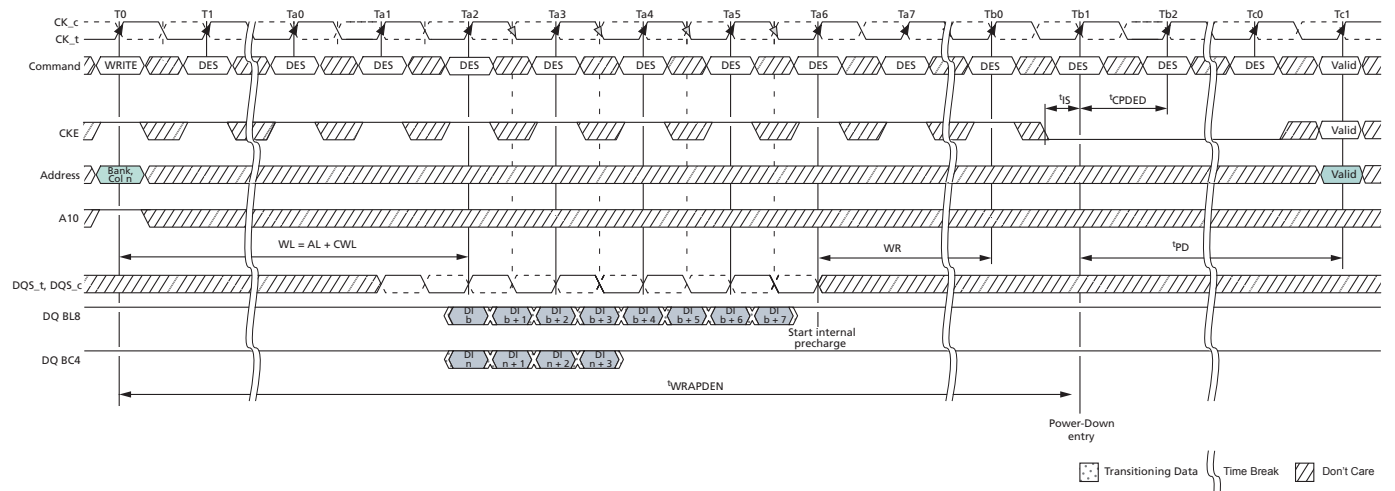
- Notes:
1. Valid commands at T0 are ACT, DES, or PRE with one bank remaining open after completion of the PRECHARGE command.
  2. ODT pin driven to a valid state; MR5[5] = 0 (normal setting).
  3. ODT pin driven to a valid state; MR5[5] = 1.

Figure 86: Power-Down Entry After Read and Read with Auto Precharge



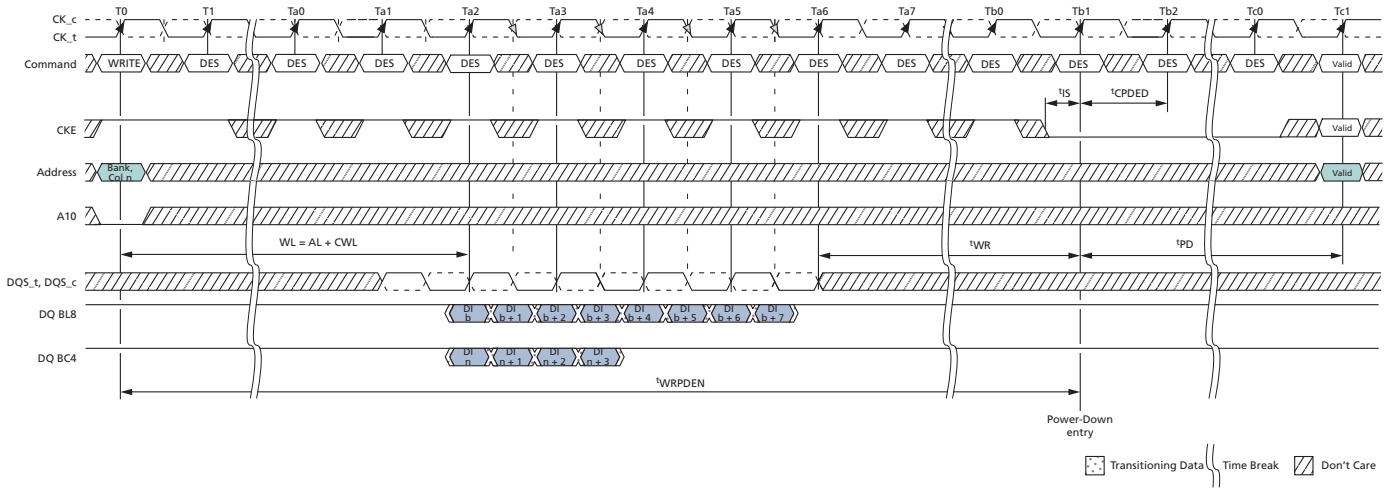
Note: 1. DI n (or b) = data-in from column n (or b).

Figure 87: Power-Down Entry After Write and Write with Auto Precharge



Notes: 1. DI n (or b) = data-in from column n (or b).  
2. Valid commands at T0 are ACT, DES, or PRE with one bank remaining open after completion of the PRECHARGE command.

Figure 88: Power-Down Entry After Write



Note: 1. DI n (or b) = data-in from column n (or b).

Figure 89: Precharge Power-Down Entry and Exit

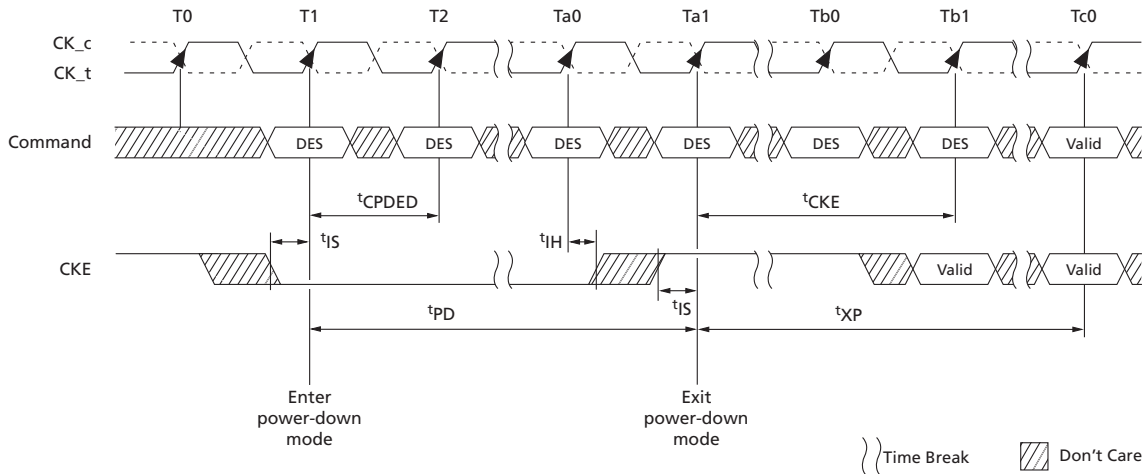


Figure 90: REFRESH Command to Power-Down Entry

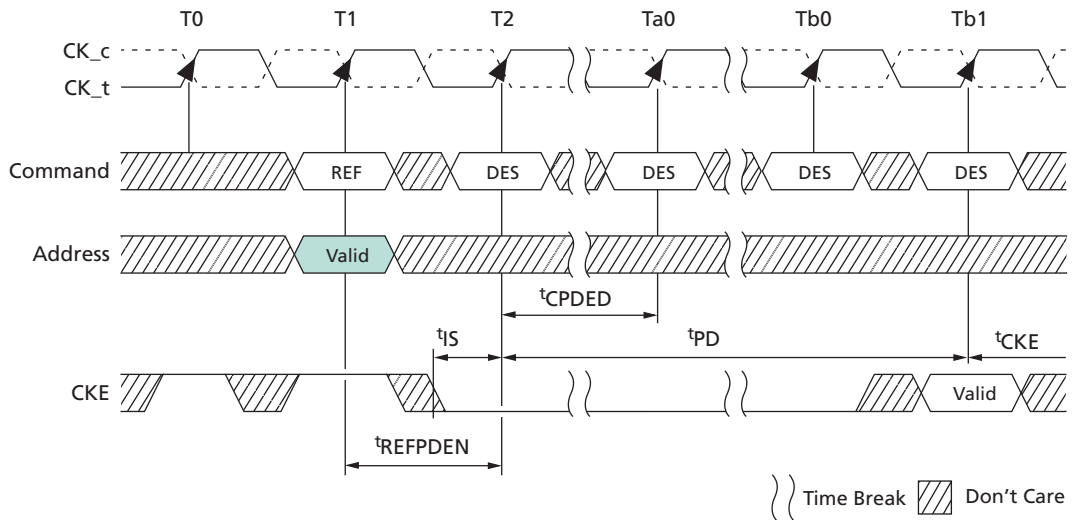


Figure 91: Active Command to Power-Down Entry

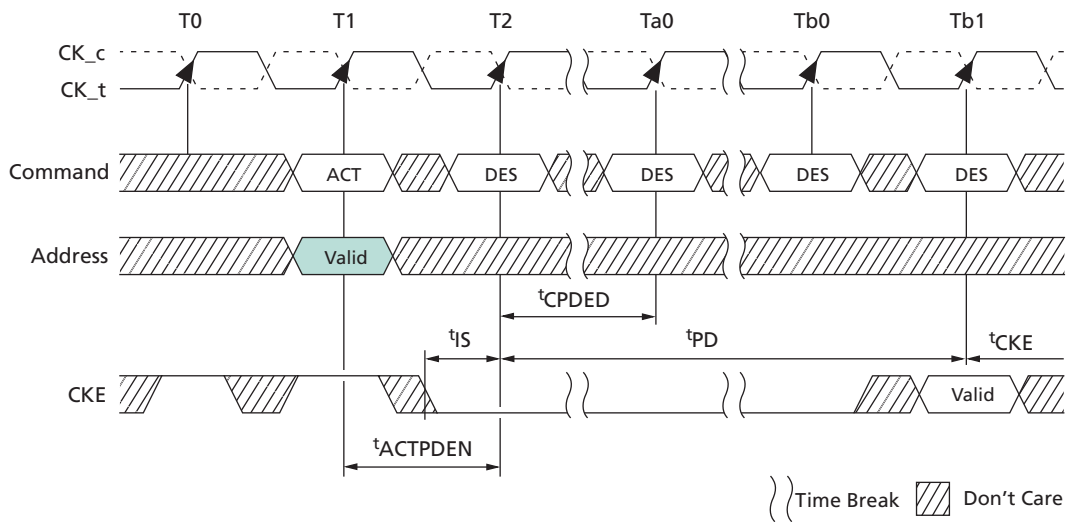


Figure 92: PRECHARGE/PRECHARGE ALL Command to Power-Down Entry

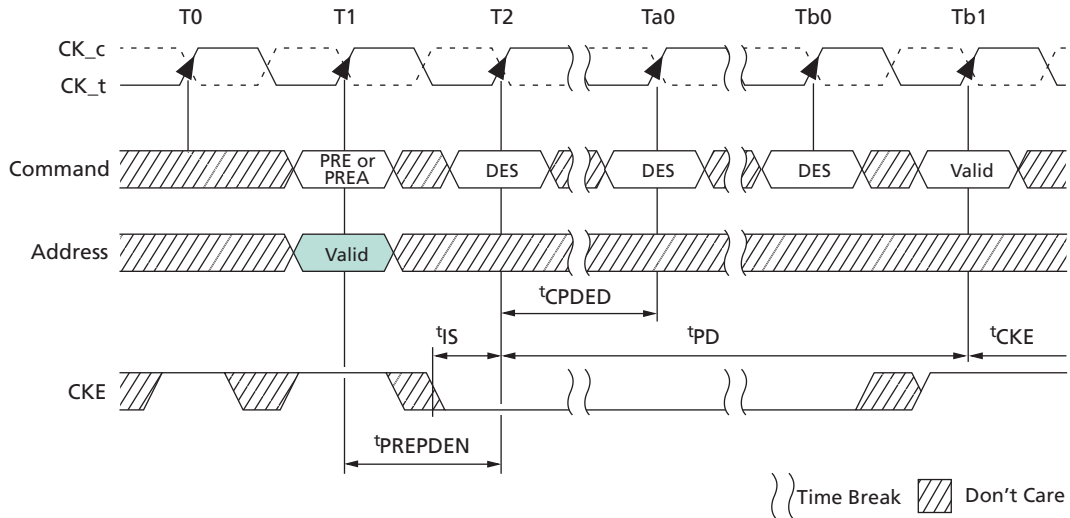
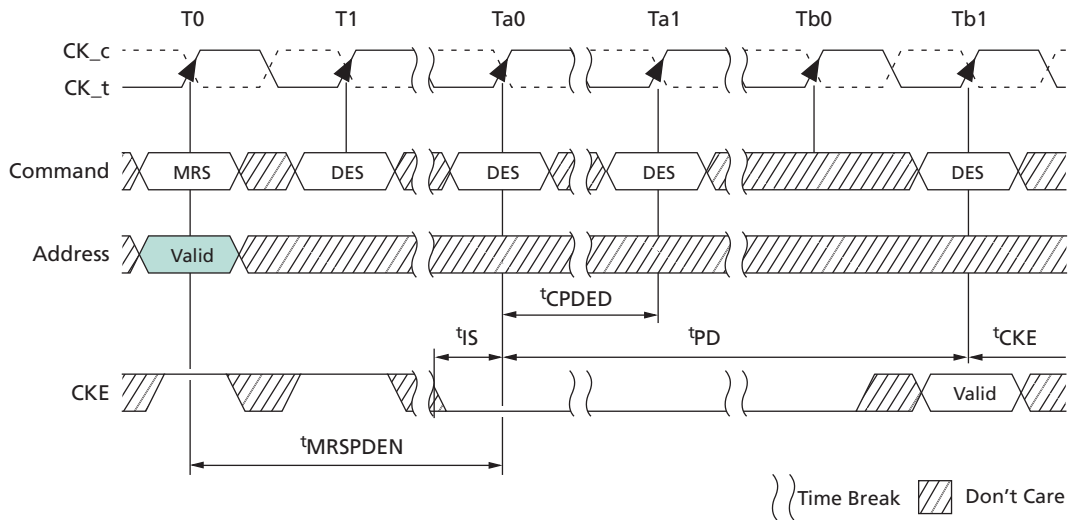


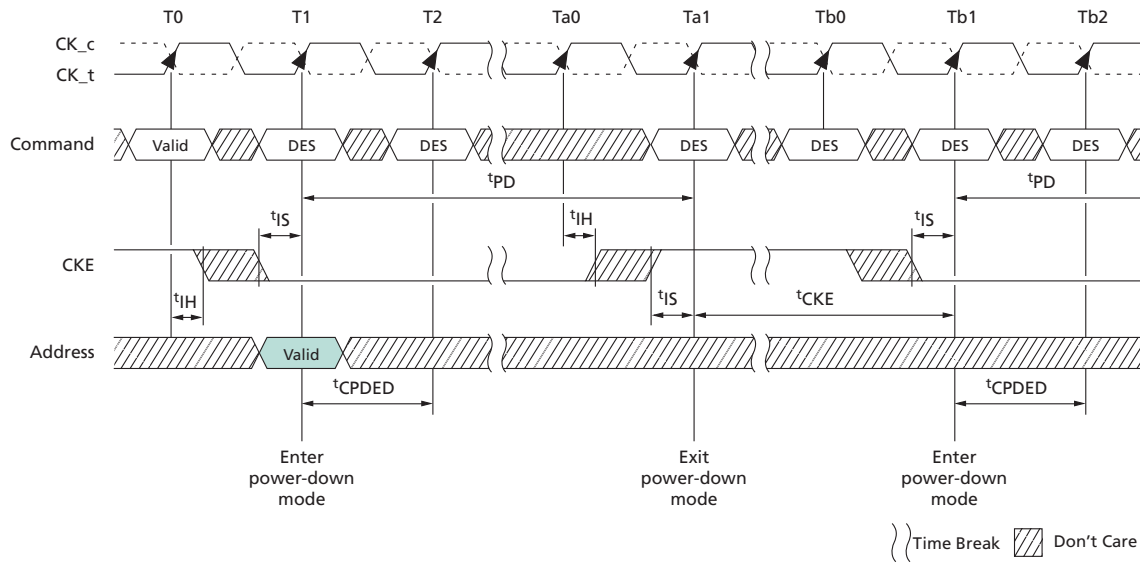
Figure 93: MRS Command to Power-Down Entry



### Power-Down Clarifications – Case 1

When CKE is registered LOW for power-down entry,  $t_{PD}$  (MIN) must be satisfied before CKE can be registered HIGH for power-down exit. The minimum value of parameter  $t_{PD}$  (MIN) is equal to the minimum value of parameter  $t_{CKE}$  (MIN) as shown in the Timing Parameters by Speed Bin table. A detailed example of Case 1 follows.

Figure 94: Power-Down Entry/Exit Clarifications – Case 1



### Power-Down Entry, Exit Timing with CAL

Command/Address latency is used and additional timing restrictions are required when entering power-down, as noted in the following figures.

Figure 95: Active Power-Down Entry and Exit Timing with CAL

Reserved For Figure

Figure 96: REFRESH Command to Power-Down Entry with CAL

Reserved For Figure

## ODT Input Buffer Disable Mode for Power-Down

ODT input buffer disable mode, when enabled via MR5[5], will prevent the device from providing  $R_{TT(NOM)}$  termination during power-down for additional power savings.

The internal delay on the CKE path to disable the ODT buffer and block the sampled output must be accounted for; therefore, ODT must be continuously driven to a valid level, either LOW or HIGH, when entering power-down. However, after  $t_{CPDED}$  (MIN) has been satisfied, the ODT signal may float.

When ODT input buffer disable mode is enabled,  $R_{TT(NOM)}$  termination corresponding to sampled ODT after CKE is first registered LOW (and  $t_{ANPD}$  before that) may not be provided.  $t_{ANPD}$  is equal to  $(WL - 1)$  and is counted backward from PDE, with CKE registered LOW.

Figure 97: ODT Power-Down Entry with ODT Buffer Disable Mode

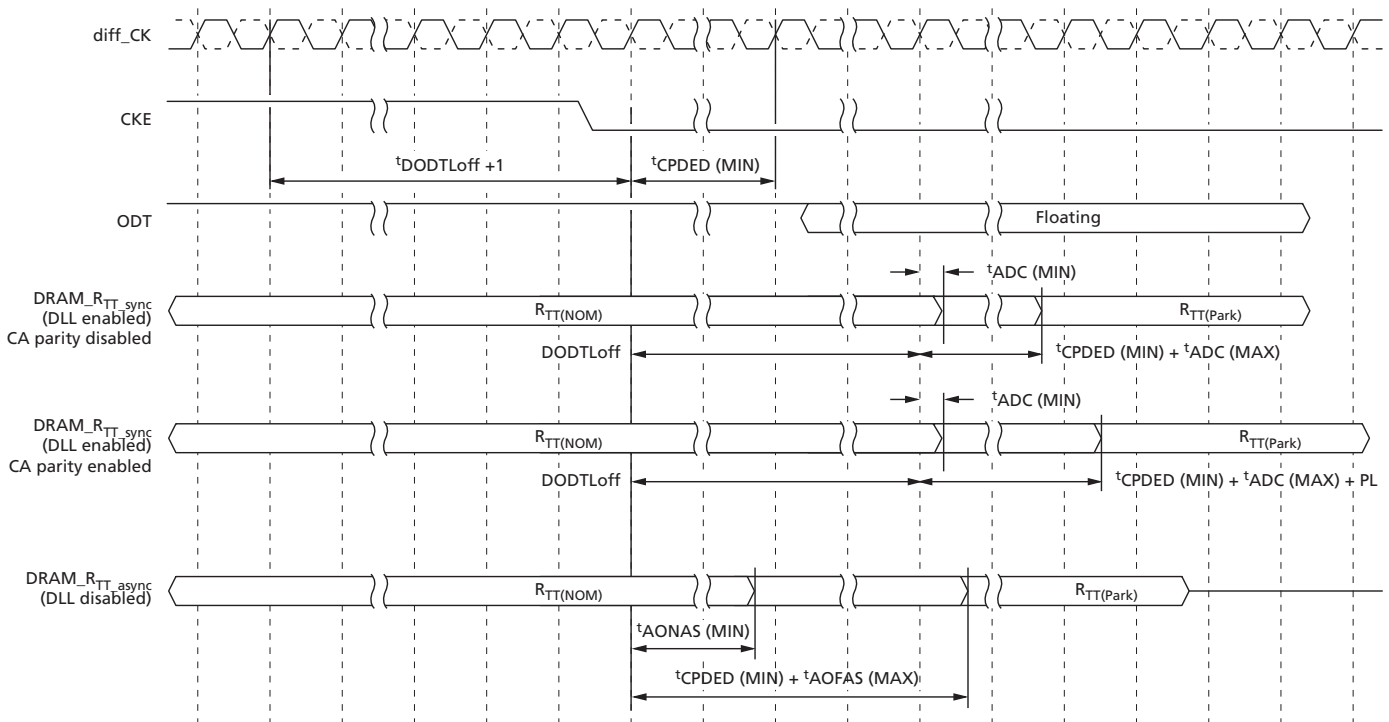
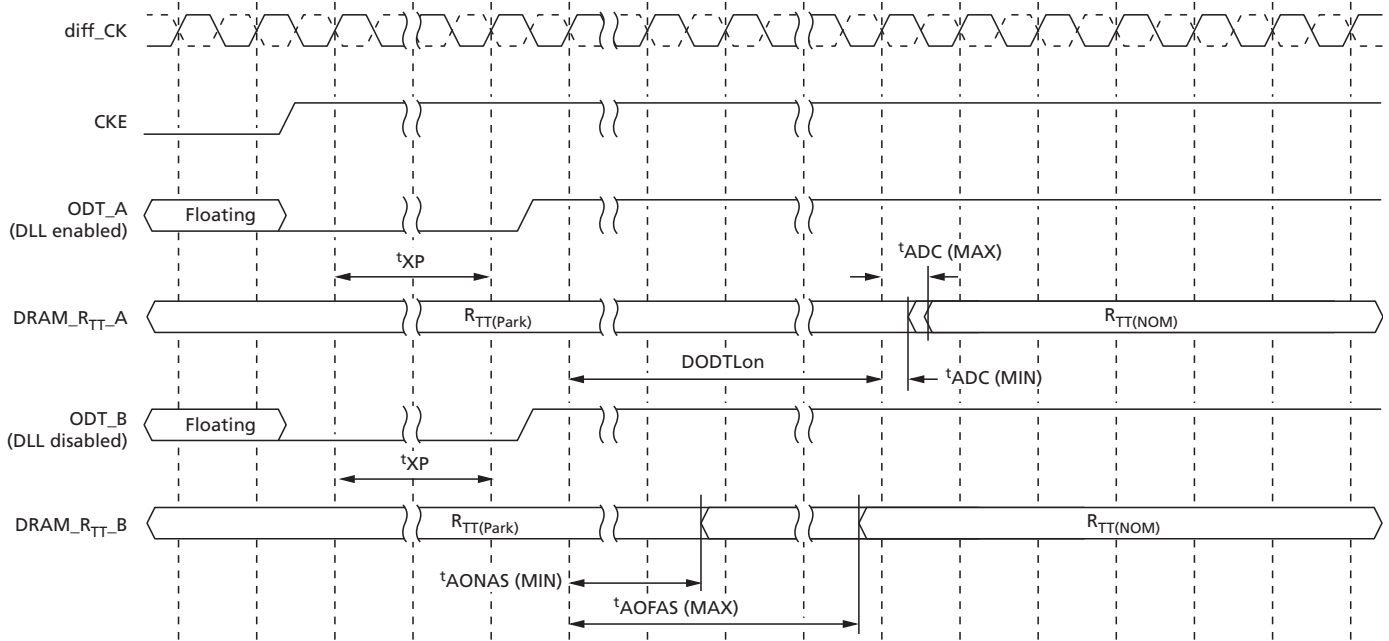


Figure 98: ODT Power-Down Exit with ODT Buffer Disable Mode

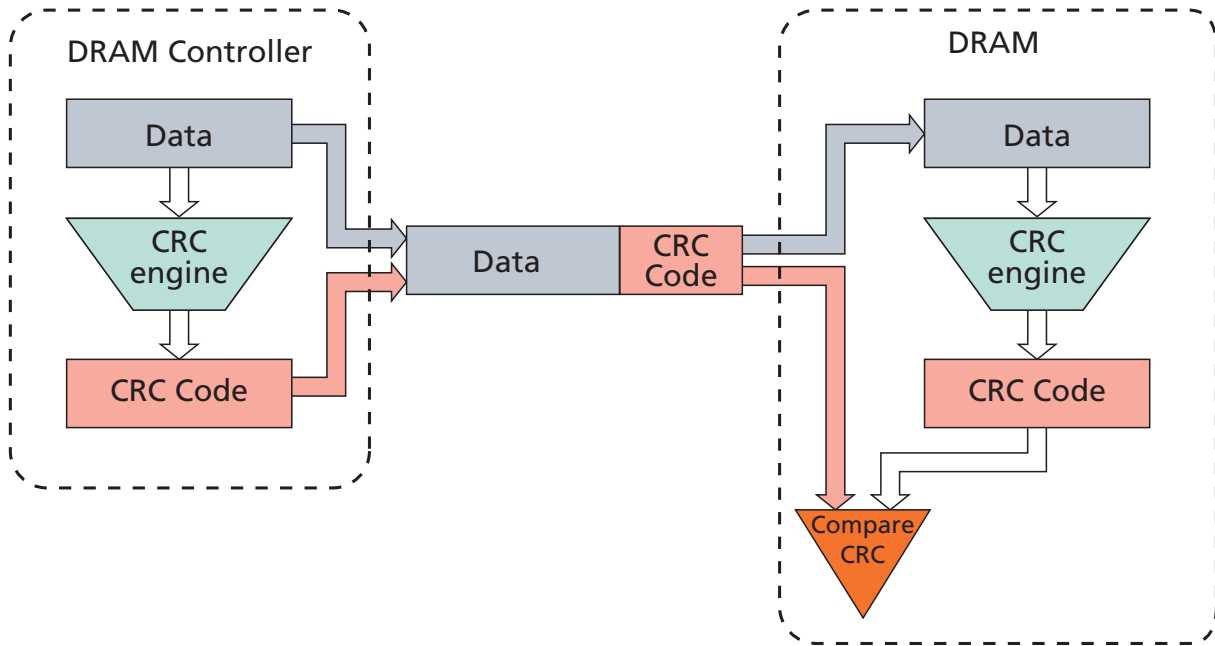


## CRC Write Data Feature

### CRC Write Data

The CRC write data feature takes the CRC generated data from the DRAM controller and compares it to the internally CRC generated data and determines whether the two match (no CRC error) or do not match (CRC error).

**Figure 99: CRC Write Data Operation**



### WRITE CRC DATA Operation

A DRAM controller generates a CRC checksum using a 72-bit CRC tree and forms the write data frames, as shown in the following CRC data mapping tables for the x4, x8, and x16 configurations. A x4 device has a CRC tree with 32 input data bits used, and the remaining upper 40 bits D[71:32] being 1s. A x8 device has a CRC tree with 64 input data bits used, and the remaining upper 8 bits dependant upon whether DM<sub>n</sub>/DBI<sub>n</sub> is used (1s are sent when not used). A x16 device has two identical CRC trees each, one for the lower byte and one for the upper byte, with 64 input data bits used by each, and the remaining upper 8 bits on each byte dependant upon whether DM<sub>n</sub>/DBI<sub>n</sub> is used (1s are sent when not used). For a x8 and x16 DRAMs, the DRAM memory controller must send 1s in transfer 9 location whether or not DM<sub>n</sub>/DBI<sub>n</sub> is used.

The DRAM checks for an error in a received code word D[71:0] by comparing the received checksum against the computed checksum and reports errors using the ALERT<sub>n</sub> signal if there is a mismatch. The DRAM can write data to the DRAM core without waiting for the CRC check for full writes when DM is disabled. If bad data is written to the DRAM core, the DRAM memory controller will try to overwrite the bad data with good data; this means the DRAM controller is responsible for data coherency when DM is disabled. However, in the case where both CRC and DM are enabled via

MRS (that is, persistent mode), the DRAM will not write bad data to the core when a CRC error is detected.

### DBI\_n and CRC Both Enabled

The DRAM computes the CRC for received written data D[71:0]. Data is not inverted back based on DBI before it is used for computing CRC. The data is inverted back based on DBI before it is written to the DRAM core.

### DM\_n and CRC Both Enabled

When both DM and write CRC are enabled in the DRAM mode register, the DRAM calculates CRC before sending the write data into the array. If there is a CRC error, the DRAM blocks the WRITE operation and discards the data. The *Nonconsecutive WRITE (BL8/BC4-OTF) with 2<sup>t</sup>CK Preamble and Write CRC in Same or Different Bank Group* and the *WRITE (BL8/BC4-OTF/Fixed) with 1<sup>t</sup>CK Preamble and Write CRC in Same or Different BankGroup* figures in the WRITE Operation section show timing differences when DM is enabled.

### DM\_n and DBI\_n Conflict During Writes with CRC Enabled

Both write DBI\_n and DM\_n can not be enabled at the same time; read DBI\_n and DM\_n can be enabled at the same time.

### CRC and Write Preamble Restrictions

When write CRC is enabled:

- And 1<sup>t</sup>CK WRITE preamble mode is enabled, a <sup>t</sup>CCD\_S or <sup>t</sup>CCD\_L of 4 clocks is not allowed.
- And 2<sup>t</sup>CK WRITE preamble mode is enabled, a <sup>t</sup>CCD\_S or <sup>t</sup>CCD\_L of 6 clocks is not allowed.

### CRC Simultaneous Operation Restrictions

When write CRC is enabled, neither MPR writes nor per-DRAM mode is allowed.

### CRC Polynomial

The CRC polynomial used by DDR4 is the ATM-8 HEC,  $X^8 + X^2 + X^1 + 1$ .

A combinatorial logic block implementation of this 8-bit CRC for 72 bits of data includes 272 two-input XOR gates contained in eight 6-XOR-gate-deep trees.

The CRC polynomial and combinatorial logic used by DDR4 is the same as used on GDDR5.

The error coverage from the DDR4 polynomial used is shown in the following table.

**Table 50: CRC Error Detection Coverage**

Error Type	Detection Capability
Random single-bit errors	100%
Random double-bit errors	100%

**Table 50: CRC Error Detection Coverage (Continued)**

Error Type	Detection Capability
Random odd count errors	100%
Random multibit UI vertical column error detection excluding DBI bits	100%

## CRC Combinatorial Logic Equations

```

module CRC8_D72;
// polynomial: (0 1 2 8)
// data width: 72
// convention: the first serial data bit is D[71]
//initial condition all 0 implied
// "^" = XOR
function [7:0]
nextCRC8_D72;
input [71:0] Data;
input [71:0] D;
reg [7:0] CRC;
begin
D = Data;

CRC[0] =
D[69]^D[68]^D[67]^D[66]^D[64]^D[63]^D[60]^D[56]^D[54]^D[53]^D[52]^D[50]^D[49]
]^D[48]^D[45]^D[43]^D[40]^D[39]^D[35]^D[34]^D[31]^D[30]^D[28]^D[23]^D[21]^D[1
9]^D[18]^D[16]^D[14]^D[12]^D[8]^D[7]^D[6]^D[0] ;

CRC[1] =
D[70]^D[66]^D[65]^D[63]^D[61]^D[60]^D[57]^D[56]^D[55]^D[52]^D[51]^D[48]^D[46]
]^D[45]^D[44]^D[43]^D[41]^D[39]^D[36]^D[34]^D[32]^D[30]^D[29]^D[28]^D[24]^D[2
3]^D[22]^D[21]^D[20]^D[18]^D[17]^D[16]^D[15]^D[14]^D[13]^D[12]^D[9]^D[6]^D[1
]^D[0];

CRC[2] =
D[71]^D[69]^D[68]^D[63]^D[62]^D[61]^D[60]^D[58]^D[57]^D[54]^D[50]^D[48]^D[47]
]^D[46]^D[44]^D[43]^D[42]^D[39]^D[37]^D[34]^D[33]^D[29]^D[28]^D[25]^D[24]^D[2
2]^D[17]^D[15]^D[13]^D[12]^D[10]^D[8]^D[6]^D[2]^D[1]^D[0];

CRC[3] =
D[70]^D[69]^D[64]^D[63]^D[62]^D[61]^D[59]^D[58]^D[55]^D[51]^D[49]^D[48]^D[47]
]^D[45]^D[44]^D[43]^D[40]^D[38]^D[35]^D[34]^D[30]^D[29]^D[26]^D[25]^D[23]^D[1
8]^D[16]^D[14]^D[13]^D[11]^D[9]^D[7]^D[3]^D[2]^D[1];

CRC[4] =
D[71]^D[70]^D[65]^D[64]^D[63]^D[62]^D[60]^D[59]^D[56]^D[52]^D[50]^D[49]^D[48]
]^D[46]^D[45]^D[44]^D[41]^D[39]^D[36]^D[35]^D[31]^D[30]^D[27]^D[26]^D[24]^D[1
9]^D[17]^D[15]^D[14]^D[12]^D[10]^D[8]^D[4]^D[3]^D[2];

CRC[5] =
D[71]^D[66]^D[65]^D[64]^D[63]^D[61]^D[60]^D[57]^D[53]^D[51]^D[50]^D[49]^D[47]
]^D[46]^D[45]^D[42]^D[40]^D[37]^D[36]^D[32]^D[31]^D[28]^D[27]^D[25]^D[20]^D[1
8]^D[16]^D[15]^D[13]^D[11]^D[9]^D[5]^D[4]^D[3];

```

$$\text{CRC}[6] = D[67] \wedge D[66] \wedge D[65] \wedge D[64] \wedge D[62] \wedge D[61] \wedge D[58] \wedge D[54] \wedge D[52] \wedge D[51] \wedge D[50] \wedge D[48] \wedge D[47] \wedge D[46] \wedge D[43] \wedge D[41] \wedge D[38] \wedge D[37] \wedge D[33] \wedge D[32] \wedge D[29] \wedge D[28] \wedge D[26] \wedge D[21] \wedge D[19] \wedge D[17] \wedge D[16] \wedge D[14] \wedge D[12] \wedge D[10] \wedge D[6] \wedge D[5] \wedge D[4];$$

$$\text{CRC}[7] = D[68] \wedge D[67] \wedge D[66] \wedge D[65] \wedge D[63] \wedge D[62] \wedge D[59] \wedge D[55] \wedge D[53] \wedge D[52] \wedge D[51] \wedge D[49] \wedge D[48] \wedge D[47] \wedge D[44] \wedge D[42] \wedge D[39] \wedge D[38] \wedge D[34] \wedge D[33] \wedge D[30] \wedge D[29] \wedge D[27] \wedge D[22] \wedge D[20] \wedge D[18] \wedge D[17] \wedge D[15] \wedge D[13] \wedge D[11] \wedge D[7] \wedge D[6] \wedge D[5];$$

$$\text{nextCRC8\_D72} = \text{CRC};$$

## Burst Ordering for BL8

DDR4 supports fixed WRITE burst ordering [A2:A1:A0 = 0:0:0] when write CRC is enabled in BL8 (fixed).

## CRC Data Bit Mapping

**Table 51: CRC Data Mapping for x4 Devices, BL8**

Function	Transfer									
	0	1	2	3	4	5	6	7	8	9
DQ0	D0	D1	D2	D3	D4	D5	D6	D7	CRC0	CRC4
DQ1	D8	D9	D10	D11	D12	D13	D14	D15	CRC1	CRC5
DQ2	D16	D17	D18	D19	D20	D21	D22	D23	CRC2	CRC6
DQ3	D24	D25	D26	D27	D28	D29	D30	D31	CRC3	CRC7

**Table 52: CRC Data Mapping for x8 Devices, BL8**

Function	Transfer									
	0	1	2	3	4	5	6	7	8	9
DQ0	D0	D1	D2	D3	D4	D5	D6	D7	CRC0	1
DQ1	D8	D9	D10	D11	D12	D13	D14	D15	CRC1	1
DQ2	D16	D17	D18	D19	D20	D21	D22	D23	CRC2	1
DQ3	D24	D25	D26	D27	D28	D29	D30	D31	CRC3	1
DQ4	D32	D33	D34	D35	D36	D37	D38	D39	CRC4	1
DQ5	D40	D41	D42	D43	D44	D45	D46	D47	CRC5	1
DQ6	D48	D49	D50	D51	D52	D53	D54	D55	CRC6	1
DQ7	D56	D57	D58	D59	D60	D61	D62	D63	CRC7	1
DM_n/ DBI_n	D64	D65	D66	D67	D68	D69	D70	D71	1	1

A x16 device is treated as two x8 devices; a x16 device will have two identical CRC trees implemented. CRC[7:0] covers data bits D[71:0], and CRC[15:8] covers data bits D[143:72].

**Table 53: CRC Data Mapping for x16 Devices, BL8**

Function	Transfer									
	0	1	2	3	4	5	6	7	8	9
DQ0	D0	D1	D2	D3	D4	D5	D6	D7	CRC0	1
DQ1	D8	D9	D10	D11	D12	D13	D14	D15	CRC1	1
DQ2	D16	D17	D18	D19	D20	D21	D22	D23	CRC2	1
DQ3	D24	D25	D26	D27	D28	D29	D30	D31	CRC3	1
DQ4	D32	D33	D34	D35	D36	D37	D38	D39	CRC4	1
DQ5	D40	D41	D42	D43	D44	D45	D46	D47	CRC5	1
DQ6	D48	D49	D50	D51	D52	D53	D54	D55	CRC6	1
DQ7	D56	D57	D58	D59	D60	D61	D62	D63	CRC7	1
LDM_n/ LDBI_n	D64	D65	D66	D67	D68	D69	D70	D71	1	1
DQ8	D72	D73	D74	D75	D76	D77	D78	D79	CRC8	1
DQ9	D80	D81	D82	D83	D84	D85	D86	D87	CRC9	1
DQ10	D88	D89	D90	D91	D92	D93	D94	D95	CRC10	1
DQ11	D96	D97	D98	D99	D100	D101	D102	D103	CRC11	1
DQ12	D104	D105	D106	D107	D108	D109	D110	D111	CRC12	1
DQ13	D112	D113	D114	D115	D116	D117	D118	D119	CRC13	1
DQ14	D120	D121	D122	D123	D124	D125	D126	D127	CRC14	1
DQ15	D128	D129	D130	D131	D132	D133	D134	D135	CRC15	1
UDM_n/ UDBI_n	D136	D137	D138	D139	D140	D141	D142	D143	1	1

### CRC Enabled With BC4

If CRC and BC4 are both enabled, then address bit A2 is used to transfer critical data first for BC4 writes.

### CRC with BC4 Data Bit Mapping

For a x4 device, the CRC tree inputs are 16 data bits, and the inputs for the remaining bits are 1.

When A2 = 1, data bits D[7:4] are used as inputs for D[3:0], D[15:12] are used as inputs to D[11:8], and so forth, for the CRC tree.

**Table 54: CRC Data Mapping for x4 Devices, BC4**

Function	Transfer									
	0	1	2	3	4	5	6	7	8	9
<b>A2 = 0</b>										
DQ0	D0	D1	D2	D3	1	1	1	1	CRC0	CRC4
DQ1	D8	D9	D10	D11	1	1	1	1	CRC1	CRC5
DQ2	D16	D17	D18	D19	1	1	1	1	CRC2	CRC6

**Table 54: CRC Data Mapping for x4 Devices, BC4 (Continued)**

Function	Transfer									
	0	1	2	3	4	5	6	7	8	9
DQ3	D24	D25	D26	D27	1	1	1	1	CRC3	CRC7
<b>A2 = 1</b>										
DQ0	D4	D5	D6	D7	1	1	1	1	CRC0	CRC4
DQ1	D12	D13	D14	D15	1	1	1	1	CRC1	CRC5
DQ2	D20	D21	D22	D23	1	1	1	1	CRC2	CRC6
DQ3	D28	D29	D30	D31	1	1	1	1	CRC3	CRC7

For a x8 device, the CRC tree inputs are 36 data bits.

When A2 = 0, the input bits D[67:64]) are used if DBI\_n or DM\_n functions are enabled; if DBI\_n and DM\_n are disabled, then D[67:64]) are 1.

When A2 = 1, data bits D[7:4] are used as inputs for D[3:0], D[15:12] are used as inputs to D[11:8], and so forth, for the CRC tree. The input bits D[71:68]) are used if DBI\_n or DM\_n functions are enabled; if DBI\_n and DM\_n are disabled, then D[71:68]) are 1.

**Table 55: CRC Data Mapping for x8 Devices, BC4**

Function	Transfer									
	0	1	2	3	4	5	6	7	8	9
<b>A2 = 0</b>										
DQ0	D0	D1	D2	D3	1	1	1	1	CRC0	1
DQ1	D8	D9	D10	D11	1	1	1	1	CRC1	1
DQ2	D16	D17	D18	D19	1	1	1	1	CRC2	1
DQ3	D24	D25	D26	D27	1	1	1	1	CRC3	1
DQ4	D32	D33	D34	D35	1	1	1	1	CRC4	1
DQ5	D40	D41	D42	D43	1	1	1	1	CRC5	1
DQ6	D48	D49	D50	D51	1	1	1	1	CRC6	1
DQ7	D56	D57	D58	D59	1	1	1	1	CRC7	1
DM_n/DBI_n	D64	D65	D66	D67	1	1	1	1	1	1
<b>A2 = 1</b>										
DQ0	D4	D5	D6	D7	1	1	1	1	CRC0	1
DQ1	D12	D13	D14	D15	1	1	1	1	CRC1	1
DQ2	D20	D21	D22	D23	1	1	1	1	CRC2	1
DQ3	D28	D29	D30	D31	1	1	1	1	CRC3	1
DQ4	D36	D37	D38	D39	1	1	1	1	CRC4	1
DQ5	D44	D45	D46	D47	1	1	1	1	CRC5	1
DQ6	D52	D53	D54	D55	1	1	1	1	CRC6	1
DQ7	D60	D61	D62	D63	1	1	1	1	CRC7	1
DM_n/DBI_n	D68	D69	D70	D71	1	1	1	1	1	1

There are two identical CRC trees for x16 devices, each have CRC tree inputs of 36 bits.

When A2 = 0, input bits D[67:64] are used if DBI\_n or DM\_n functions are enabled; if DBI\_n and DM\_n are disabled, then D[67:64] are 1s. The input bits D[139:136] are used if DBI\_n or DM\_n functions are enabled; if DBI\_n and DM\_n are disabled, then D[139:136] are 1s.

When A2 = 1, data bits D[7:4] are used as inputs for D[3:0], D[15:12] are used as inputs for D[11:8], and so forth, for the CRC tree. Input bits D[71:68] are used if DBI\_n or DM\_n functions are enabled; if DBI\_n and DM\_n are disabled, then D[71:68] are 1s. The input bits D[143:140] are used if DBI\_n or DM\_n functions are enabled; if DBI\_n and DM\_n are disabled, then D[143:140] are 1s.

**Table 56: CRC Data Mapping for x16 Devices, BC4**

Function	Transfer									
	0	1	2	3	4	5	6	7	8	9
<b>A2 = 0</b>										
DQ0	D0	D1	D2	D3	1	1	1	1	CRC0	1
DQ1	D8	D9	D10	D11	1	1	1	1	CRC1	1
DQ2	D16	D17	D18	D19	1	1	1	1	CRC2	1
DQ3	D24	D25	D26	D27	1	1	1	1	CRC3	1
DQ4	D32	D33	D34	D35	1	1	1	1	CRC4	1
DQ5	D40	D41	D42	D43	1	1	1	1	CRC5	1
DQ6	D48	D49	D50	D51	1	1	1	1	CRC6	1
DQ7	D56	D57	D58	D59	1	1	1	1	CRC7	1
LDM_n/LDBI_n	D64	D65	D66	D67	1	1	1	1	1	1
DQ8	D72	D73	D74	D75	1	1	1	1	CRC8	1
DQ9	D80	D81	D82	D83	1	1	1	1	CRC9	1
DQ10	D88	D89	D90	D91	1	1	1	1	CRC10	1
DQ11	D96	D97	D98	D99	1	1	1	1	CRC11	1
DQ12	D104	D105	D106	D107	1	1	1	1	CRC12	1
DQ13	D112	D113	D114	D115	1	1	1	1	CRC13	1
DQ14	D120	D121	D122	D123	1	1	1	1	CRC14	1
DQ15	D128	D129	D130	D131	1	1	1	1	CRC15	1
UDM_n/UDBI_n	D136	D137	D138	D139	1	1	1	1	1	1
<b>A2 = 1</b>										
DQ0	D4	D5	D6	D7	1	1	1	1	CRC0	1
DQ1	D12	D13	D14	D15	1	1	1	1	CRC1	1
DQ2	D20	D21	D22	D23	1	1	1	1	CRC2	1
DQ3	D28	D29	D30	D31	1	1	1	1	CRC3	1
DQ4	D36	D37	D38	D39	1	1	1	1	CRC4	1
DQ5	D44	D45	D46	D47	1	1	1	1	CRC5	1
DQ6	D52	D53	D54	D55	1	1	1	1	CRC6	1
DQ7	D60	D61	D62	D63	1	1	1	1	CRC7	1
LDM_n/LDBI_n	D68	D69	D70	D71	1	1	1	1	1	1

**Table 56: CRC Data Mapping for x16 Devices, BC4 (Continued)**

Function	Transfer									
	0	1	2	3	4	5	6	7	8	9
DQ8	D76	D77	D78	D79	1	1	1	1	CRC8	1
DQ9	D84	D85	D86	D87	1	1	1	1	CRC9	1
DQ10	D92	D93	D94	D95	1	1	1	1	CRC10	1
DQ11	D100	D101	D102	D103	1	1	1	1	CRC11	1
DQ12	D108	D109	D110	D111	1	1	1	1	CRC12	1
DQ13	D116	D117	D118	D119	1	1	1	1	CRC13	1
DQ14	D124	D125	D126	D127	1	1	1	1	CRC14	1
DQ15	D132	D133	D134	D135	1	1	1	1	CRC15	1
UDM_n/UDBI_n	D140	D141	D142	D143	1	1	1	1	1	1

**CRC Equations for x8 Device in BC4 Mode with A2 = 0 and A2 = 1**

The following example is of a CRC tree when x8 is used in BC4 mode (x4 and x16 CRC trees have similar differences).

**CRC[0], A2=0 =**

$$1 \wedge 1 \wedge D[67] \wedge D[66] \wedge D[64] \wedge 1 \wedge 1 \wedge D[56] \wedge 1 \wedge 1 \wedge 1 \wedge D[50] \wedge D[49] \wedge D[48] \wedge 1 \wedge D[43] \wedge D[40] \wedge 1 \wedge D[35] \wedge D[34] \wedge 1 \wedge 1 \wedge 1 \wedge 1 \wedge 1 \wedge D[19] \wedge D[18] \wedge D[16] \wedge 1 \wedge 1 \wedge 1 \wedge D[8] \wedge 1 \wedge 1 \wedge 1 \wedge D[0];$$

**CRC[0], A2=1 =**

$$1 \wedge 1 \wedge D[71] \wedge D[70] \wedge D[68] \wedge 1 \wedge 1 \wedge D[60] \wedge 1 \wedge 1 \wedge 1 \wedge D[54] \wedge D[53] \wedge D[52] \wedge 1 \wedge D[47] \wedge D[44] \wedge 1 \wedge D[39] \wedge D[38] \wedge 1 \wedge 1 \wedge 1 \wedge 1 \wedge 1 \wedge D[23] \wedge D[22] \wedge D[20] \wedge 1 \wedge 1 \wedge 1 \wedge D[12] \wedge 1 \wedge 1 \wedge 1 \wedge D[4];$$

**CRC[1], A2=0 =**

$$1 \wedge D[66] \wedge D[65] \wedge 1 \wedge 1 \wedge 1 \wedge D[57] \wedge D[56] \wedge 1 \wedge 1 \wedge D[51] \wedge D[48] \wedge 1 \wedge 1 \wedge 1 \wedge D[43] \wedge D[41] \wedge 1 \wedge 1 \wedge D[34] \wedge D[32] \wedge 1 \wedge 1 \wedge 1 \wedge D[24] \wedge 1 \wedge 1 \wedge 1 \wedge 1 \wedge D[18] \wedge D[17] \wedge D[16] \wedge 1 \wedge 1 \wedge 1 \wedge 1 \wedge D[9] \wedge 1 \wedge D[1] \wedge D[0];$$

**CRC[1], A2=1 =**

$$1 \wedge D[70] \wedge D[69] \wedge 1 \wedge 1 \wedge 1 \wedge D[61] \wedge D[60] \wedge 1 \wedge 1 \wedge D[55] \wedge D[52] \wedge 1 \wedge 1 \wedge 1 \wedge D[47] \wedge D[45] \wedge 1 \wedge 1 \wedge D[38] \wedge D[36] \wedge 1 \wedge 1 \wedge 1 \wedge 1 \wedge D[28] \wedge 1 \wedge 1 \wedge 1 \wedge 1 \wedge D[22] \wedge D[21] \wedge D[20] \wedge 1 \wedge 1 \wedge 1 \wedge 1 \wedge D[13] \wedge 1 \wedge D[5] \wedge D[4];$$

**CRC[2], A2=0 =**

$$1 \wedge 1 \wedge 1 \wedge 1 \wedge 1 \wedge 1 \wedge 1 \wedge D[58] \wedge D[57] \wedge 1 \wedge D[50] \wedge D[48] \wedge 1 \wedge 1 \wedge 1 \wedge D[43] \wedge D[42] \wedge 1 \wedge 1 \wedge D[34] \wedge D[33] \wedge 1 \wedge 1 \wedge D[25] \wedge D[24] \wedge 1 \wedge D[17] \wedge 1 \wedge 1 \wedge 1 \wedge 1 \wedge D[10] \wedge D[8] \wedge 1 \wedge D[2] \wedge D[1] \wedge D[0];$$

**CRC[2], A2=1 =**

$$1 \wedge 1 \wedge 1 \wedge 1 \wedge 1 \wedge 1 \wedge 1 \wedge D[62] \wedge D[61] \wedge 1 \wedge D[54] \wedge D[52] \wedge 1 \wedge 1 \wedge 1 \wedge D[47] \wedge D[46] \wedge 1 \wedge 1 \wedge D[38] \wedge D[37] \wedge 1 \wedge 1 \wedge D[29] \wedge D[28] \wedge 1 \wedge D[21] \wedge 1 \wedge 1 \wedge 1 \wedge 1 \wedge D[14] \wedge D[12] \wedge 1 \wedge D[6] \wedge D[5] \wedge D[4];$$

**CRC[3], A2=0 =**

$$1 \wedge 1 \wedge D[64] \wedge 1 \wedge 1 \wedge 1 \wedge D[59] \wedge D[58] \wedge 1 \wedge D[51] \wedge D[49] \wedge D[48] \wedge 1 \wedge 1 \wedge 1 \wedge D[43] \wedge D[40] \wedge 1 \wedge D[35] \wedge D[34] \wedge 1 \wedge 1 \wedge D[26] \wedge D[25] \wedge 1 \wedge D[18] \wedge D[16] \wedge 1 \wedge 1 \wedge D[11] \wedge D[9] \wedge 1 \wedge D[3] \wedge D[2] \wedge D[1];$$

**CRC[3], A2=1 =**

$$1 \wedge 1 \wedge D[68] \wedge 1 \wedge 1 \wedge 1 \wedge D[63] \wedge D[62] \wedge 1 \wedge D[55] \wedge D[53] \wedge D[52] \wedge 1 \wedge 1 \wedge 1 \wedge D[47] \wedge D[44] \wedge 1 \wedge D[39] \wedge D[38] \wedge 1 \wedge 1 \wedge D[30] \wedge D[29] \wedge 1 \wedge D[22] \wedge D[20] \wedge 1 \wedge 1 \wedge D[15] \wedge D[13] \wedge 1 \wedge D[7] \wedge D[6] \wedge D[5];$$

**CRC[4], A2=0 =**

$$1 \wedge D[65] \wedge D[64] \wedge 1 \wedge 1 \wedge 1 \wedge D[59] \wedge D[56] \wedge 1 \wedge D[50] \wedge D[49] \wedge D[48] \wedge 1 \wedge 1 \wedge 1 \wedge D[41] \wedge 1 \wedge 1 \wedge D[35] \wedge 1 \wedge 1 \wedge D[27] \wedge D[26] \wedge D[24] \wedge D[19] \wedge D[17] \wedge 1 \wedge 1 \wedge 1 \wedge D[10] \wedge D[8] \wedge 1 \wedge D[3] \wedge D[2];$$

**CRC[4], A2=1 =**

$$1 \wedge 1 \wedge D[69] \wedge D[68] \wedge 1 \wedge 1 \wedge 1 \wedge D[63] \wedge D[60] \wedge 1 \wedge D[54] \wedge D[53] \wedge D[52] \wedge 1 \wedge 1 \wedge 1 \wedge D[45] \wedge 1 \wedge 1 \wedge D[39] \wedge 1 \wedge 1 \wedge D[31] \wedge D[30] \wedge D[28] \wedge D[23] \wedge D[21] \wedge 1 \wedge 1 \wedge 1 \wedge D[14] \wedge D[12] \wedge 1 \wedge D[7] \wedge D[6];$$

**CRC[5], A2=0 =**

$$1 \wedge D[66] \wedge D[65] \wedge D[64] \wedge 1 \wedge 1 \wedge 1 \wedge D[57] \wedge 1 \wedge D[51] \wedge D[50] \wedge D[49] \wedge 1 \wedge 1 \wedge 1 \wedge D[42] \wedge D[40] \wedge 1 \wedge 1 \wedge D[32] \wedge 1 \wedge 1 \wedge D[27] \wedge D[25] \wedge 1 \wedge D[18] \wedge D[16] \wedge 1 \wedge 1 \wedge D[11] \wedge D[9] \wedge 1 \wedge 1 \wedge D[3];$$

**CRC[5], A2=1 =**

$$1 \wedge D[70] \wedge D[69] \wedge D[68] \wedge 1 \wedge 1 \wedge 1 \wedge D[61] \wedge 1 \wedge D[55] \wedge D[54] \wedge D[53] \wedge 1 \wedge 1 \wedge 1 \wedge D[46] \wedge D[44] \wedge 1 \wedge 1 \wedge D[36] \wedge 1 \wedge 1 \wedge D[31] \wedge D[29] \wedge 1 \wedge D[22] \wedge D[20] \wedge 1 \wedge 1 \wedge D[15] \wedge D[13] \wedge 1 \wedge 1 \wedge D[7];$$

**CRC[6], A2=0 =**

$$D[67] \wedge D[66] \wedge D[65] \wedge D[64] \wedge 1 \wedge 1 \wedge D[58] \wedge 1 \wedge 1 \wedge D[51] \wedge D[50] \wedge D[48] \wedge 1 \wedge 1 \wedge D[43] \wedge D[41] \wedge 1 \wedge 1 \wedge D[33] \wedge D[32] \wedge 1 \wedge 1 \wedge D[26] \wedge 1 \wedge D[19] \wedge D[17] \wedge D[16] \wedge 1 \wedge 1 \wedge D[10] \wedge 1 \wedge 1 \wedge 1;$$

**CRC[6], A2=1 =**

$$D[71] \wedge D[70] \wedge D[69] \wedge D[68] \wedge 1 \wedge 1 \wedge D[62] \wedge 1 \wedge 1 \wedge D[55] \wedge D[54] \wedge D[52] \wedge 1 \wedge 1 \wedge D[47] \wedge D[45] \wedge 1 \wedge 1 \wedge D[37] \wedge D[36] \wedge 1 \wedge 1 \wedge D[30] \wedge 1 \wedge D[23] \wedge D[21] \wedge D[20] \wedge 1 \wedge 1 \wedge D[14] \wedge 1 \wedge 1 \wedge 1;$$

**CRC[7], A2=0 =**

$$1 \wedge D[67] \wedge D[66] \wedge D[65] \wedge 1 \wedge 1 \wedge D[59] \wedge 1 \wedge 1 \wedge 1 \wedge D[51] \wedge D[49] \wedge D[48] \wedge 1 \wedge 1 \wedge D[42] \wedge 1 \wedge 1 \wedge D[34] \wedge D[33] \wedge 1 \wedge 1 \wedge D[27] \wedge 1 \wedge 1 \wedge D[18] \wedge D[17] \wedge 1 \wedge 1 \wedge D[11] \wedge 1 \wedge 1 \wedge 1;$$

**CRC[7], A2=1 =**

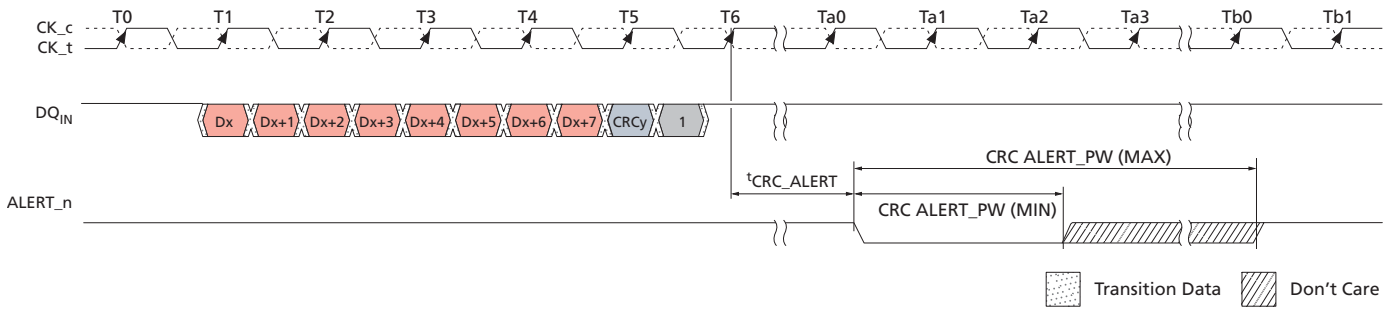
$$1 \wedge D[71] \wedge D[70] \wedge D[69] \wedge 1 \wedge 1 \wedge D[63] \wedge 1 \wedge 1 \wedge 1 \wedge D[55] \wedge D[53] \wedge D[52] \wedge 1 \wedge 1 \wedge D[46] \wedge 1 \wedge 1 \wedge D[38] \wedge D[37] \wedge 1 \wedge 1 \wedge D[31] \wedge 1 \wedge 1 \wedge D[22] \wedge D[21] \wedge 1 \wedge 1 \wedge D[15] \wedge 1 \wedge 1 \wedge 1;$$

## CRC Error Handling

The CRC error mechanism shares the same ALERT\_n signal as CA parity for reporting write errors to the DRAM. The controller has two ways to distinguish between CRC errors and CA parity errors: 1) Read DRAM mode/MPR registers, and 2) Measure time ALERT\_n is LOW. To speed up recovery for CRC errors, CRC errors are only sent back as a "short" pulse; the maximum pulse width is roughly ten clocks (unlike CA parity where ALERT\_n is LOW longer than 45 clocks). The ALERT\_n LOW could be longer than the maximum limit at the controller if there are multiple CRC errors as the ALERT\_n signals are connected by a daisy chain bus. The latency to ALERT\_n signal is defined as tCRC\_ALERT in the following figure.

The DRAM will set the error status bit located at MR5[3] to a 1 upon detecting a CRC error, which will subsequently set the CRC error status flag in the MPR error log HIGH (MPR Page1, MPR3[7]). The CRC error status bit (and CRC error status flag) remains set at 1 until the DRAM controller clears the CRC error status bit using an MRS command to set MR5[3] to a 0. The DRAM controller, upon seeing an error as a pulse width, will retry the write transactions. The controller should consider the worst-case delay for ALERT\_n (during initialization) and backup the transactions accordingly. The DRAM controller may also be made more intelligent and correlate the write CRC error to a specific rank or a transaction.

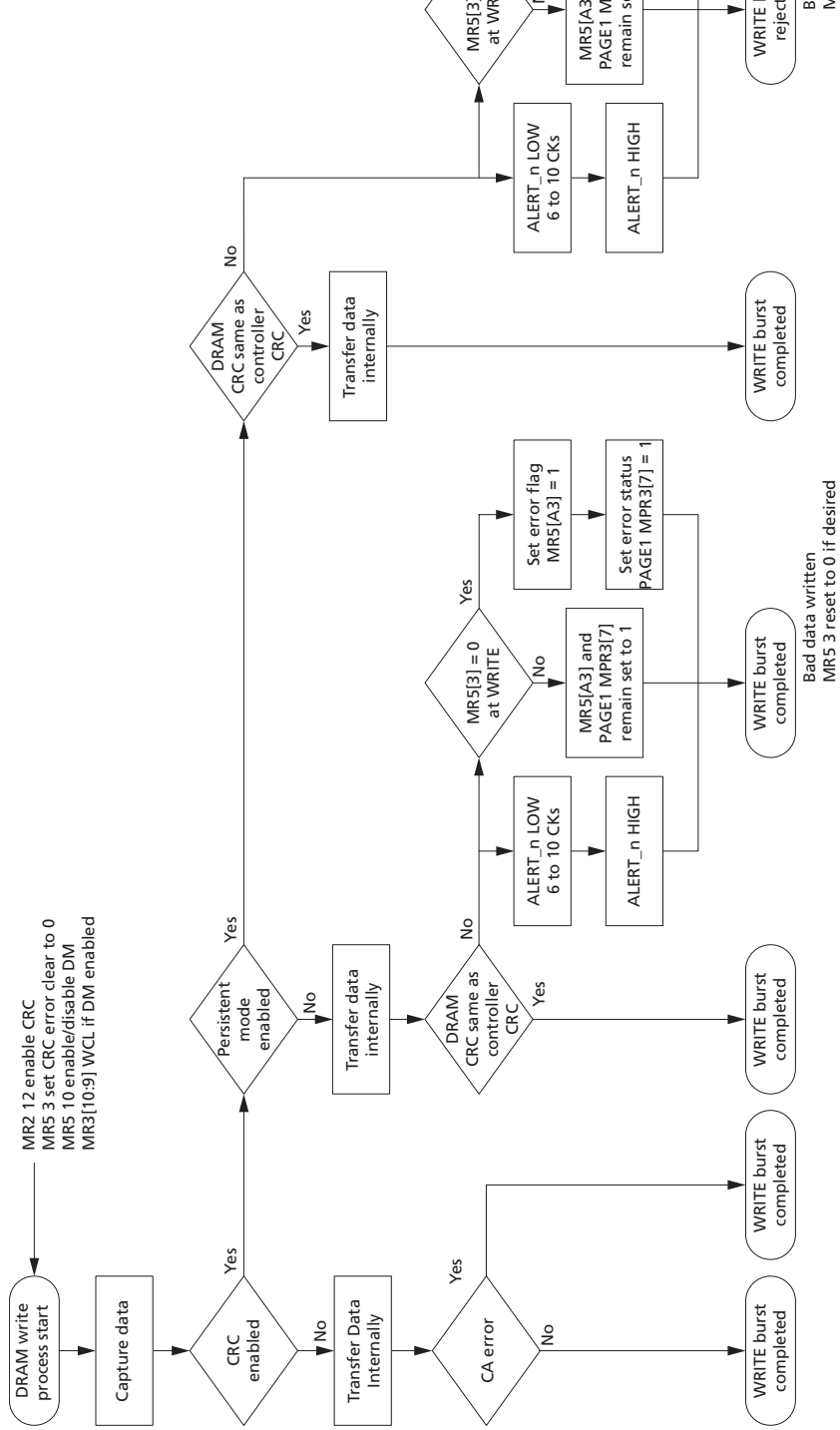
**Figure 100: CRC Error Reporting**



- Notes:
1. D[71:1] CRC computed by DRAM did not match CRC[7:0] at T5 and started error generating process at T6.
  2. CRC ALERT\_PW is specified from the point where the DRAM starts to drive the signal LOW to the point where the DRAM driver releases and the controller starts to pull the signal up.
  3. Timing diagram applies to x4, x8, and x16 devices.

# CRC Write Data Flow Diagram

## Figure 101: CA Parity Flow Diagram



## Data Bus Inversion

The DATA BUS INVERSION (DBI) function is supported only for x8 and x16 configurations (it is not supported on x4 devices). DBI opportunistically inverts data bits, and in conjunction with the DBI\_n I/O, less than half of the DQs will switch LOW for a given DQS strobe edge. The DBI function shares a common pin with the DATA MASK (DM) and TDQS functions. The DBI function applies to either or both READ and WRITE operations: Write DBI cannot be enabled at the same time the DM function is enabled, and DBI is not allowed during MPR READ operation. Valid configurations for TDQS, DM, and DBI functions are shown below.

**Table 57: DBI vs. DM vs. TDQS Function Matrix**

Read DBI	Write DBI	Data Mask (DM)	TDQS (x8 only)
<b>Enabled</b> (or Disabled)	Disabled	Disabled	Disabled
Enabled or Disabled	<b>Enabled</b>	Disabled	Disabled
Enabled or Disabled	Disabled	<b>Enabled</b>	Disabled
Disabled	Disabled	Disabled	<b>Enabled</b>

## DBI During a WRITE Operation

If DBI\_n is sampled LOW on a given byte lane during a WRITE operation, the DRAM inverts write data received on the DQ inputs prior to writing the internal memory array. If DBI\_n is sampled HIGH on a given byte lane, the DRAM leaves the data received on the DQ inputs noninverted. The write DQ frame format is shown below for x8 and x16 configurations (the x4 configuration does not support the DBI function).

**Table 58: DBI Write, DQ Frame Format (x8)**

Function	Transfer							
	0	1	2	3	4	5	6	7
DQ[7:0]	Byte 0	Byte 1	Byte 2	Byte 3	Byte 4	Byte 5	Byte 6	Byte 7
DM_n or DBI_n	DM0 or DBI0	DM1 or DBI1	DM2 or DBI2	DM3 or DBI3	DM4 or DBI4	DM5 or DBI5	DM6 or DBI6	DM7 or DBI7

**Table 59: DBI Write, DQ Frame Format (x16)**

Function	Transfer, Lower (L) and Upper(U)							
	0	1	2	3	4	5	6	7
DQ[7:0]	LByte 0	LByte 1	LByte 2	LByte 3	LByte 4	LByte 5	LByte 6	LByte 7
LDM_n or LDBI_n	LDM0 or LDBI0	LDM1 or LDBI1	LDM2 or LDBI2	LDM3 or LDBI3	LDM4 or LDBI4	LDM5 or LDBI5	LDM6 or LDBI6	LDM7 or LDBI7
DQ[15:8]	UByte 0	UByte 1	UByte 2	UByte 3	UByte 4	UByte 5	UByte 6	UByte 7
UDM_n or UDBI_n	UDM0 or UDBI0	UDM1 or UDBI1	UDM2 or UDBI2	UDM3 or UDBI3	UDM4 or UDBI4	UDM5 or UDBI5	UDM6 or UDBI6	UDM7 or UDBI7

## DBI During a READ Operation

If the number of 0 data bits within a given byte lane is greater than four during a READ operation, the DRAM inverts read data on its DQ outputs and drives the DBI\_n pin LOW; otherwise, the DRAM does not invert the read data and drives the DBI\_n pin HIGH. The read DQ frame format is shown below for x8 and x16 configurations (the x4 configuration does not support the DBI function).

**Table 60: DBI Read, DQ Frame Format (x8)**

Function	Transfer Byte							
	0	1	2	3	4	5	6	7
DQ[7:0]	Byte 0	Byte 1	Byte 2	Byte 3	Byte 4	Byte 5	Byte 6	Byte 7
DBI_n	DBI0	DBI1	DBI2	DBI3	DBI4	DBI5	DBI6	DBI7

**Table 61: DBI Read, DQ Frame Format (x16)**

Function	Transfer Byte, Lower (L) and Upper(U)							
	0	1	2	3	4	5	6	7
DQ[7:0]	LByte 0	LByte 1	LByte 2	LByte 3	LByte 4	LByte 5	LByte 6	LByte 7
LDBI_n	LDBI0	LDBI1	LDBI2	LDBI3	LDBI4	LDBI5	LDBI6	LDBI7
DQ[15:8]	UByte 0	UByte 1	UByte 2	UByte 3	UByte 4	UByte 5	UByte 6	UByte 7
UDBI_n	UDBI0	UDBI1	UDBI2	UDBI3	UDBI4	UDBI5	UDBI6	UDBI7

## Data Mask

The DATA MASK (DM) function, also described as PARTIAL WRITE, is supported only for x8 and x16 configurations (it is not supported on x4 devices). The DM function shares a common pin with the DBI\_n and TDQS functions. The DM function applies only to WRITE operations and cannot be enabled at the same time the WRITE DBI function is enabled. The valid configurations for the TDQS, DM, and DBI functions are shown here.

**Table 62: DM vs. TDQS vs. DBI Function Matrix**

Data Mask (DM)	TDQS (x8 only)	Write DBI	Read DBI
<b>Enabled</b>	Disabled	Disabled	Enabled or Disabled
Disabled	<b>Enabled</b>	Disabled	Disabled
	Disabled	<b>Enabled</b>	Enabled or Disabled
	Disabled	Disabled	<b>Enabled</b> (or Disabled)

When enabled, the DM function applies during a WRITE operation. If DM\_n is sampled LOW on a given byte lane, the DRAM masks the write data received on the DQ inputs. If DM\_n is sampled HIGH on a given byte lane, the DRAM does not mask the data and writes this data into the DRAM core. The DQ frame format for x8 and x16 configurations is shown below. If both CRC write and DM are enabled (via MRS), the CRC will be checked and valid prior to the DRAM writing data into the DRAM core. If a CRC error occurs while the DM feature is enabled, CRC write persistent mode will be enabled and data will not be written into the DRAM core. In the case of CRC write enabled and DM disabled (via MRS), that is, CRC write nonpersistent mode, data is written to the DRAM core even if a CRC error occurs.

**Table 63: Data Mask, DQ Frame Format (x8)**

Function	Transfer							
	0	1	2	3	4	5	6	7
DQ[7:0]	Byte 0	Byte 1	Byte 2	Byte 3	Byte 4	Byte 5	Byte 6	Byte 7
DM_n or DBI_n	DM0 or DBI0	DM1 or DBI1	DM2 or DBI2	DM3 or DBI3	DM4 or DBI4	DM5 or DBI5	DM6 or DBI6	DM7 or DBI7

**Table 64: Data Mask, DQ Frame Format (x16)**

Function	Transfer, Lower (L) and Upper (U)							
	0	1	2	3	4	5	6	7
DQ[7:0]	LByte 0	LByte 1	LByte 2	LByte 3	LByte 4	LByte 5	LByte 6	LByte 7
LDM_n or LDBI_n	LDM0 or LDBI0	LDM1 or LDBI1	LDM2 or LDBI2	LDM3 or LDBI3	LDM4 or LDBI4	LDM5 or LDBI5	LDM6 or LDBI6	LDM7 or LDBI7
DQ[15:8]	UByte 0	UByte 1	UByte 2	UByte 3	UByte 4	UByte 5	UByte 6	UByte 7
UDM_n or UDBI_n	UDM0 or UDBI0	UDM1 or UDBI1	UDM2 or UDBI2	UDM3 or UDBI3	UDM4 or UDBI4	UDM5 or UDBI5	UDM6 or UDBI6	UDM7 or UDBI7

## Programmable Preamble Modes and DQS Postambles

The device supports programmable WRITE and READ preamble modes, either the normal 1<sup>t</sup>CK preamble mode or special 2<sup>t</sup>CK preamble mode. The 2<sup>t</sup>CK preamble mode places special timing constraints on many operational features as well as being supported for data rates of DDR4-2400 and faster. The WRITE preamble 1<sup>t</sup>CK or 2<sup>t</sup>CK mode can be selected independently from READ preamble 1<sup>t</sup>CK or 2<sup>t</sup>CK mode.

READ preamble training is also supported; this mode can be used by the DRAM controller to train or "read level" the DQS receivers.

There are <sup>t</sup>CCD restrictions under some circumstances:

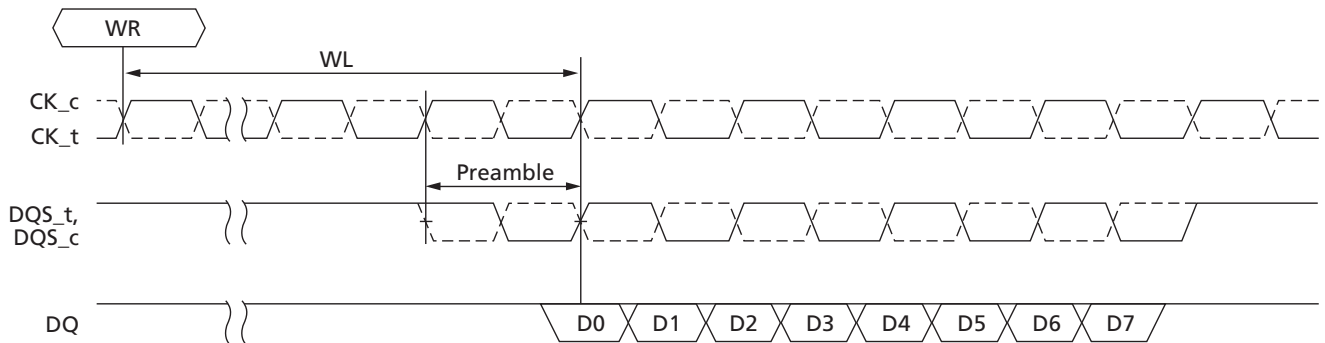
- When 2<sup>t</sup>CK READ preamble mode is enabled, a <sup>t</sup>CCD\_S or <sup>t</sup>CCD\_L of 5 clocks is not allowed.
- When 2<sup>t</sup>CK WRITE preamble mode is enabled and write CRC is *not* enabled, a <sup>t</sup>CCD\_S or <sup>t</sup>CCD\_L of 5 clocks is not allowed.
- When 2<sup>t</sup>CK WRITE preamble mode is enabled and write CRC is enabled, a <sup>t</sup>CCD\_S or <sup>t</sup>CCD\_L of 6 clocks is not allowed.

### WRITE Preamble Mode

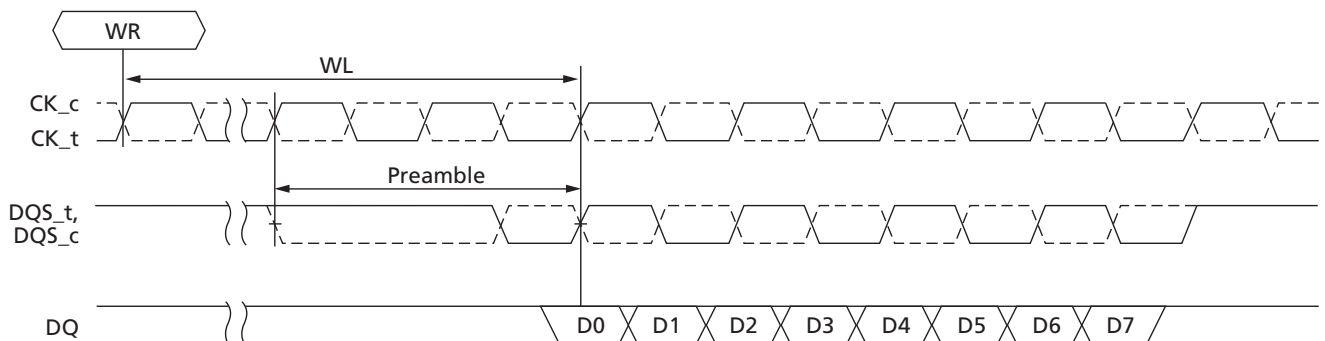
MR4[12] = 0 selects 1<sup>t</sup>CK WRITE preamble mode while MR4[12] = 1 selects 2<sup>t</sup>CK WRITE preamble mode. Examples are shown in the figures below.

Figure 102: 1<sup>t</sup>CK vs. 2<sup>t</sup>CK WRITE Preamble Mode

#### 1<sup>t</sup>CK Mode



#### 2<sup>t</sup>CK Mode



CWL has special considerations when in the 2<sup>t</sup>CK WRITE preamble mode. The CWL value selected in MR2[5:3], as seen in table below, requires at least one additional clock when the primary CWL value and 2<sup>t</sup>CK WRITE preamble mode are used; no additional clocks are required when the alternate CWL value and 2<sup>t</sup>CK WRITE preamble mode are used.

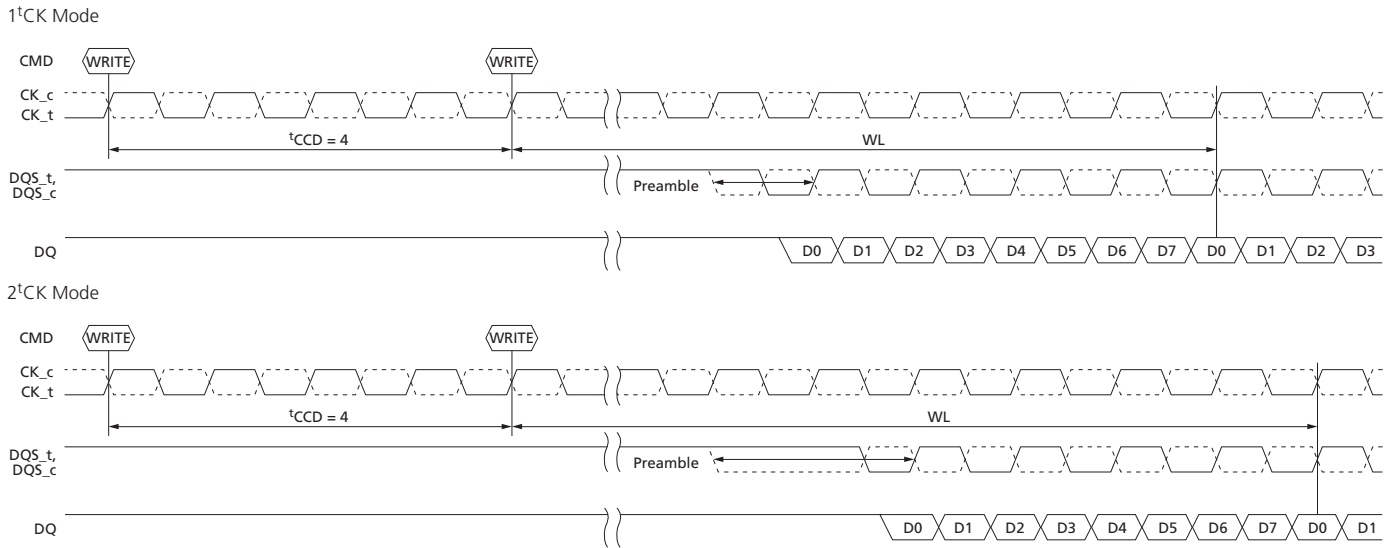
**Table 65: CWL Selection**

Speed Bin	CWL - Primary Choice		CWL - Alternate Choice	
	1 <sup>t</sup> CK Preamble	2 <sup>t</sup> CK Preamble	1 <sup>t</sup> CK Preamble	2 <sup>t</sup> CK Preamble
DDR4-1600	9	N/A	11	N/A
DDR4-1866	10	N/A	12	N/A
DDR4-2133	11	N/A	14	N/A
DDR4-2400	12	14	16	16
DDR4-2666	14	16	18	18
DDR4-2933	16	18	20	20
DDR4-3200	16	18	20	20

Note: 1. CWL programmable requirement for MR2[5:3].

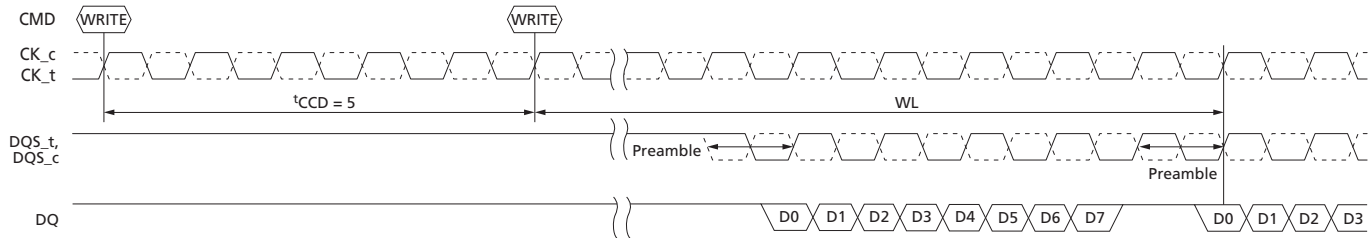
When operating in 2<sup>t</sup>CK WRITE preamble mode, <sup>t</sup>WTR (command based) and <sup>t</sup>WR (MR0[11:9]) must be programmed to a value 1 clock greater than the <sup>t</sup>WTR and <sup>t</sup>WR setting normally required for the applicable speed bin to be JEDEC compliant; however, Micron's DDR4 DRAMs do not require these additional <sup>t</sup>WTR and <sup>t</sup>WR clocks. The CAS<sub>n</sub>-to-CAS<sub>n</sub> command delay to either a different bank group (<sup>t</sup>CCD<sub>S</sub>) or the same bank group (<sup>t</sup>CCD<sub>L</sub>) have minimum timing requirements that must be satisfied between WRITE commands and are stated in the Timing Parameters by Speed Bin tables. When operating in 2<sup>t</sup>CK WRITE preamble mode, <sup>t</sup>CCD<sub>S</sub> and <sup>t</sup>CCD<sub>L</sub> must also be an even number of clocks. As an example, if the minimum timing specification requires only 5<sup>t</sup>CK, the 5<sup>t</sup>CK has to be rounded up to 6<sup>t</sup>CK when operating in 2<sup>t</sup>CK WRITE preamble mode, while 5<sup>t</sup>CK would be acceptable if operating in 1<sup>t</sup>CK WRITE preamble mode.

**Figure 103: 1<sup>t</sup>CK vs. 2<sup>t</sup>CK WRITE Preamble Mode, t<sub>CCD</sub> = 4**



**Figure 104: 1<sup>t</sup>CK vs. 2<sup>t</sup>CK WRITE Preamble Mode, t<sub>CCD</sub> = 5**

1<sup>t</sup>CK Mode

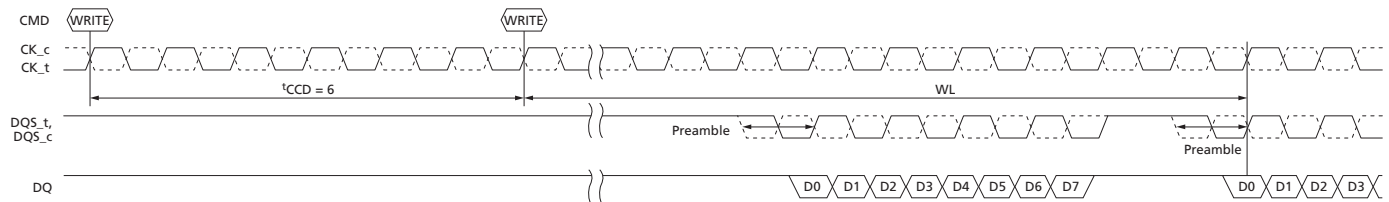


2<sup>t</sup>CK Mode: t<sub>CCD</sub> = 5 is not allowed in 2<sup>t</sup>CK mode.

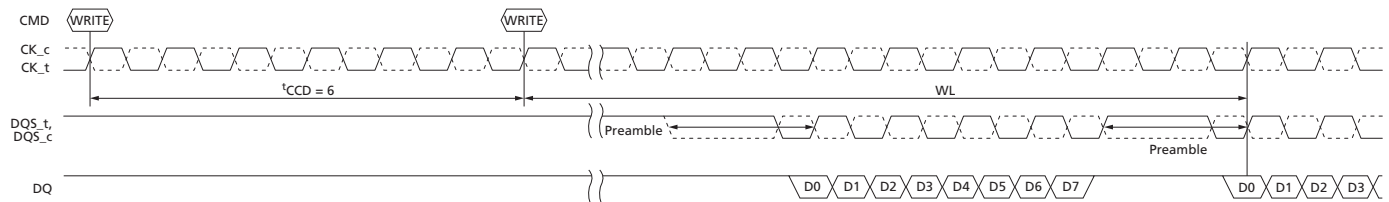
Note: 1. t<sub>CCD\_S</sub> and t<sub>CCD\_L</sub> = 5 t<sub>CK</sub>s is not allowed when in 2<sup>t</sup>CK WRITE preamble mode.

**Figure 105: 1<sup>t</sup>CK vs. 2<sup>t</sup>CK WRITE Preamble Mode, t<sub>CCD</sub> = 6**

1<sup>t</sup>CK Mode



2<sup>t</sup>CK Mode

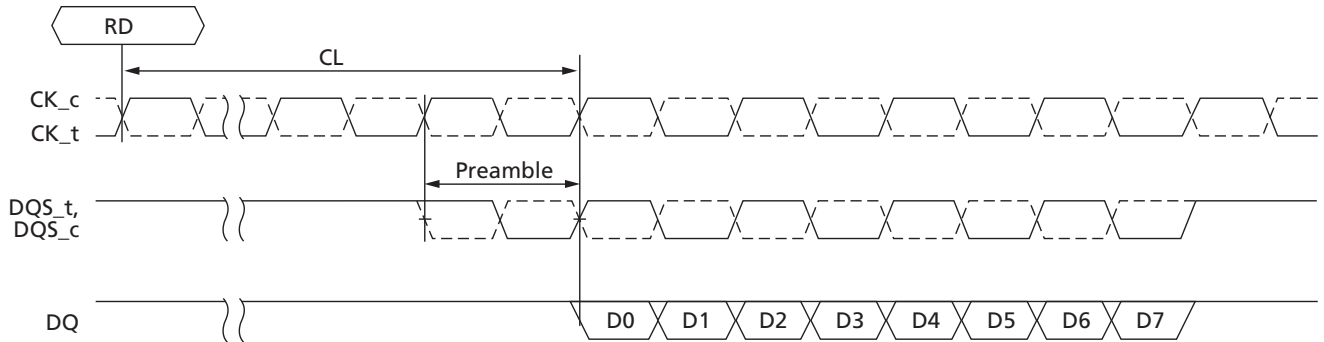


### READ Preamble Mode

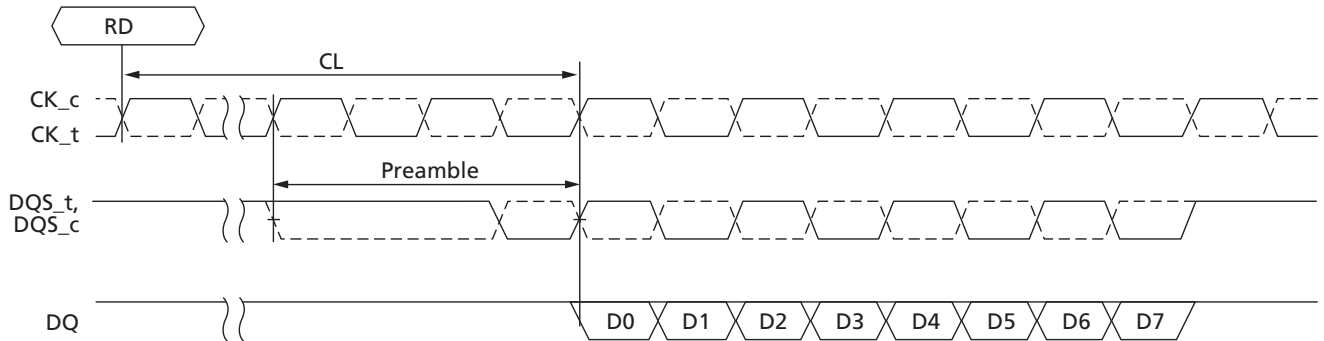
MR4[11] = 0 selects 1<sup>t</sup>CK READ preamble mode and MR4[12] = 1 selects 2<sup>t</sup>CK READ preamble mode. Examples are shown in the following figure.

**Figure 106: 1<sup>t</sup>CK vs. 2<sup>t</sup>CK READ Preamble Mode**

#### 1<sup>t</sup>CK Mode



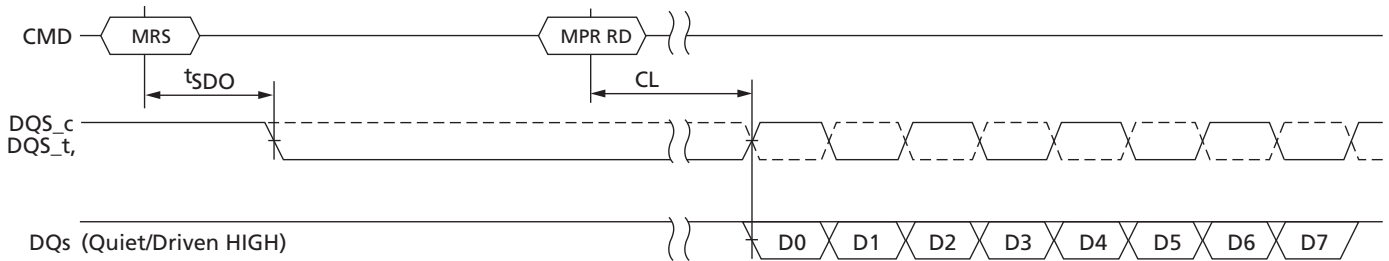
#### 2<sup>t</sup>CK Mode



### READ Preamble Training

DDR4 supports READ preamble training via MPR reads; that is, READ preamble training is allowed only when the DRAM is in the MPR access mode. The READ preamble training mode can be used by the DRAM controller to train or "read level" its DQS receivers. READ preamble training is entered via an MRS command (MR4[10] = 1 is enabled and MR4[10] = 0 is disabled). After the MRS command is issued to enable READ preamble training, the DRAM DQS signals are driven to a valid level by the time 'SDO is satisfied. During this time, the data bus DQ signals are held quiet, that is, driven HIGH. The DQS<sub>t</sub> signal remains driven LOW and the DQS<sub>c</sub> signal remains driven HIGH until an MPR Page0 READ command is issued (MPR0 through MPR3 determine which pattern is used), and when CAS latency (CL) has expired, the DQS signals will toggle normally depending on the burst length setting. To exit READ preamble training mode, an MRS command must be issued, MR4[10] = 0.

**Figure 107: READ Preamble Training**

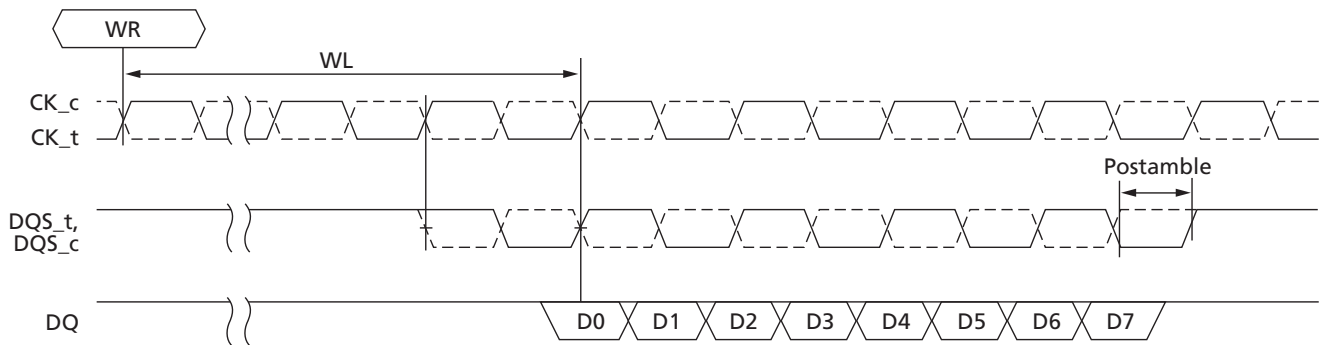


**WRITE Postamble**

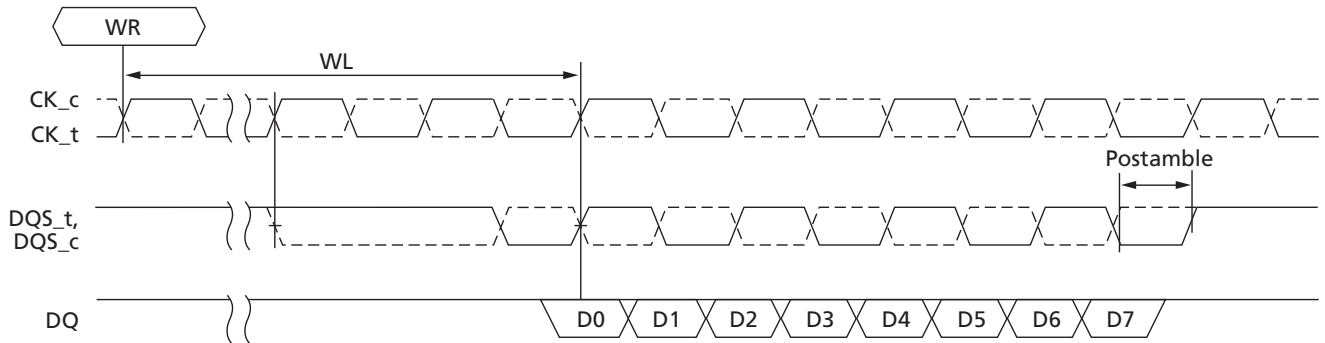
Whether the 1<sup>t</sup>CK or 2<sup>t</sup>CK WRITE preamble mode is selected, the WRITE postamble remains the same at ½<sup>t</sup>CK.

**Figure 108: WRITE Postamble**

**1<sup>t</sup>CK Mode**



**2<sup>t</sup>CK Mode**

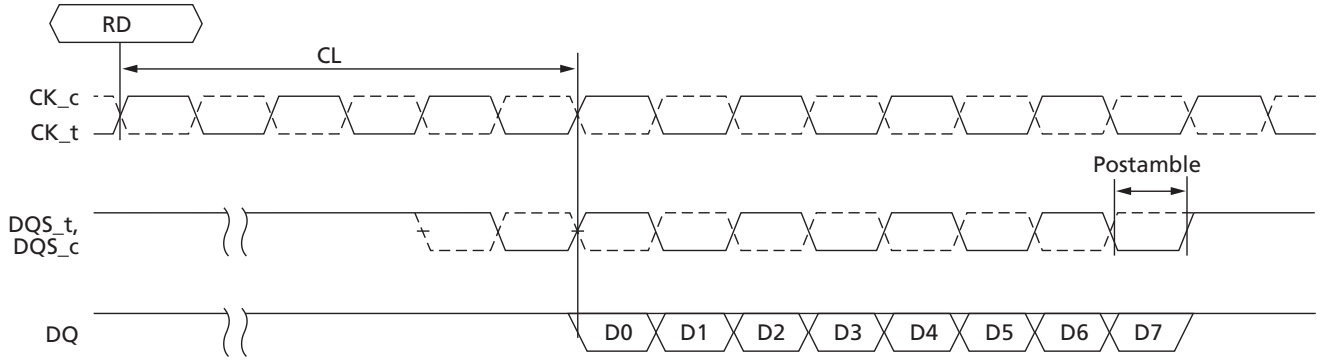


**READ Postamble**

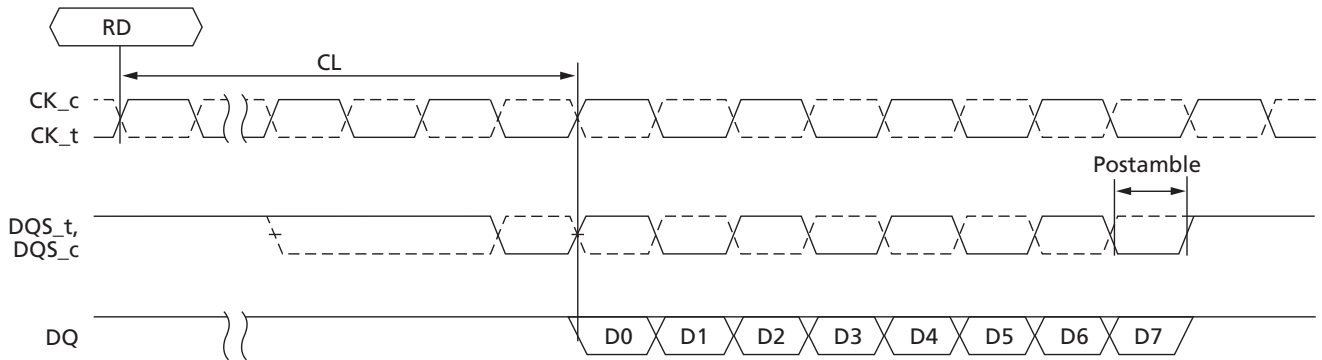
Whether the 1<sup>t</sup>CK or 2<sup>t</sup>CK READ preamble mode is selected, the READ postamble remains the same at ½<sup>t</sup>CK.

**Figure 109: READ Postamble**

**1<sup>t</sup>CK Mode**



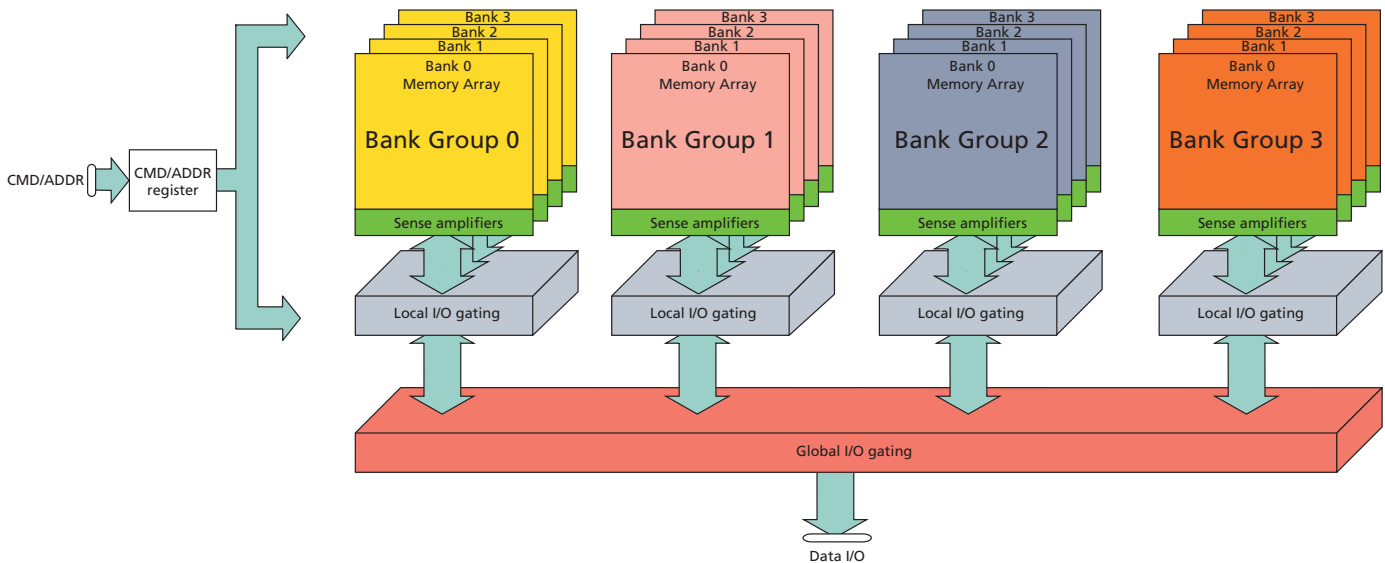
**2<sup>t</sup>CK Mode**



## Bank Access Operation

DDR4 supports bank grouping: x4/x8 DRAMs have four bank groups (BG[1:0]), and each bank group is comprised of four subbanks (BA[1:0]); x16 DRAMs have two bank groups (BG[0]), and each bank group is comprised of four subbanks. Bank accesses to different banks' groups require less time delay between accesses than bank accesses to within the same bank's group. Bank accesses to different bank groups require  $t_{CCD\_S}$  (or short) delay between commands while bank accesses within the same bank group require  $t_{CCD\_L}$  (or long) delay between commands.

**Figure 110: Bank Group x4/x8 Block Diagram**



- Notes: 1. Bank accesses to different bank groups require  $t_{CCD\_S}$ .  
2. Bank accesses within the same bank group require  $t_{CCD\_L}$ .

**Table 66: DDR4 Bank Group Timing Examples**

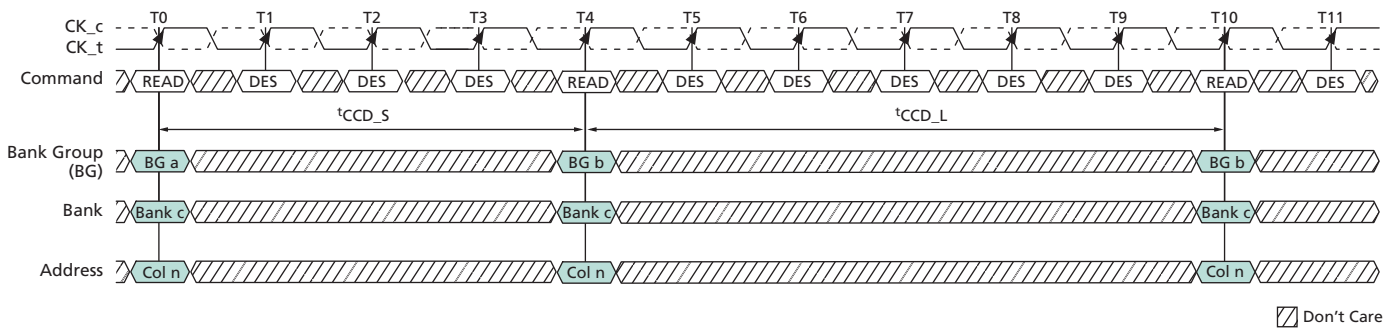
Parameter	DDR4-1600	DDR4-2133	DDR4-2400
$t_{CCD\_S}$	4nCK	4nCK	4nCK
$t_{CCD\_L}$	4nCK or 6.25ns	4nCK or 5.355ns	4nCK or 5ns
$t_{RRD\_S}$ (½K)	4nCK or 5ns	4nCK or 3.7ns	4nCK or 3.3ns
$t_{RRD\_L}$ (½K)	4nCK or 6ns	4nCK or 5.3ns	4nCK or 4.9ns
$t_{RRD\_S}$ (1K)	4nCK or 5ns	4nCK or 3.7ns	4nCK or 3.3ns
$t_{RRD\_L}$ (1K)	4nCK or 6ns	4nCK or 5.3ns	4nCK or 4.9ns
$t_{RRD\_S}$ (2K)	4nCK or 6ns	4nCK or 5.3ns	4nCK or 5.3ns
$t_{RRD\_L}$ (2K)	4nCK or 7.5ns	4nCK or 6.4ns	4nCK or 6.4ns

**Table 66: DDR4 Bank Group Timing Examples (Continued)**

Parameter	DDR4-1600	DDR4-2133	DDR4-2400
$t^{\text{WTR}}_{\text{S}}$	2nCK or 2.5ns	2nCK or 2.5ns	2nCK or 2.5ns
$t^{\text{WTR}}_{\text{L}}$	4nCK or 7.5ns	4nCK or 7.5ns	4nCK or 7.5ns

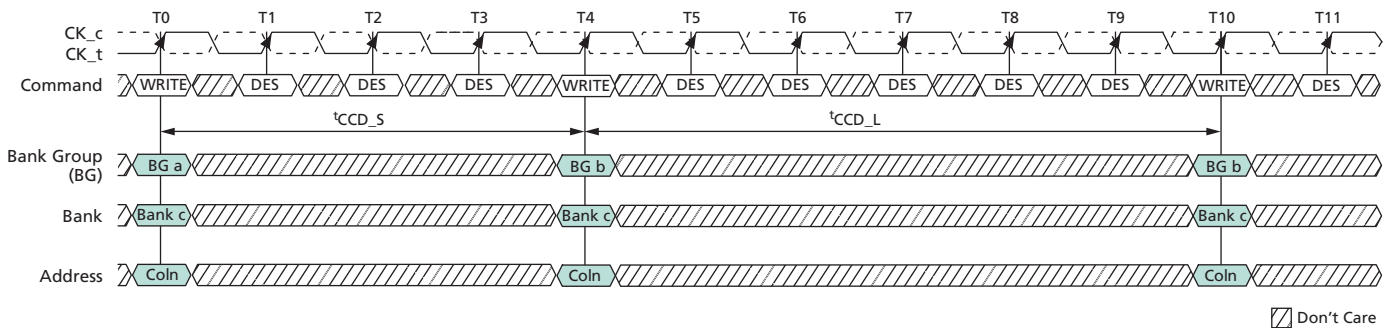
- Notes:
1. Refer to Timing Tables for actual specification values, these values are shown for reference only and are not verified for accuracy.
  2. Timings with both nCK and ns require both to be satisfied; that is, the larger time of the two cases must be satisfied.

**Figure 111: READ Burst  $t^{\text{CCD}}_{\text{S}}$  and  $t^{\text{CCD}}_{\text{L}}$  Examples**



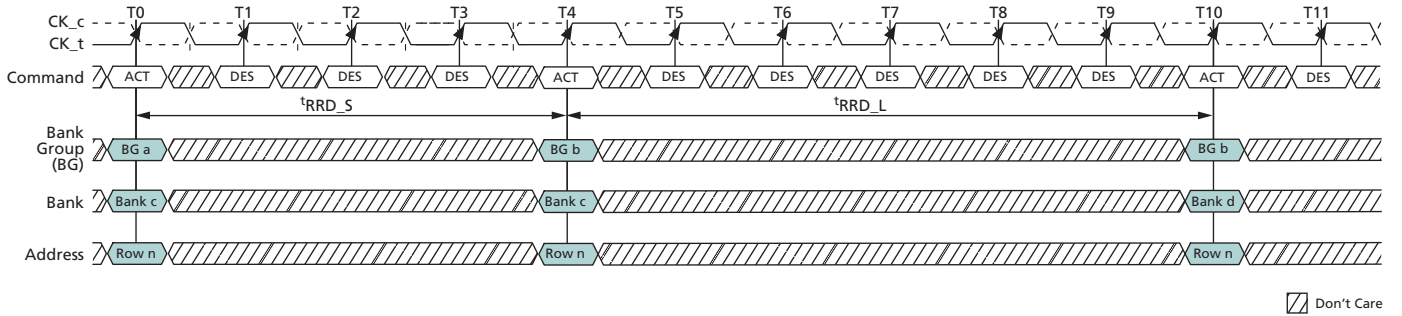
- Notes:
1.  $t^{\text{CCD}}_{\text{S}}$ ; CAS<sub>n</sub>-to-CAS<sub>n</sub> delay (short). Applies to consecutive CAS<sub>n</sub> to different bank groups (T0 to T4).
  2.  $t^{\text{CCD}}_{\text{L}}$ ; CAS<sub>n</sub>-to-CAS<sub>n</sub> delay (long). Applies to consecutive CAS<sub>n</sub> to the same bank group (T4 to T10).

**Figure 112: Write Burst  $t^{\text{CCD}}_{\text{S}}$  and  $t^{\text{CCD}}_{\text{L}}$  Examples**



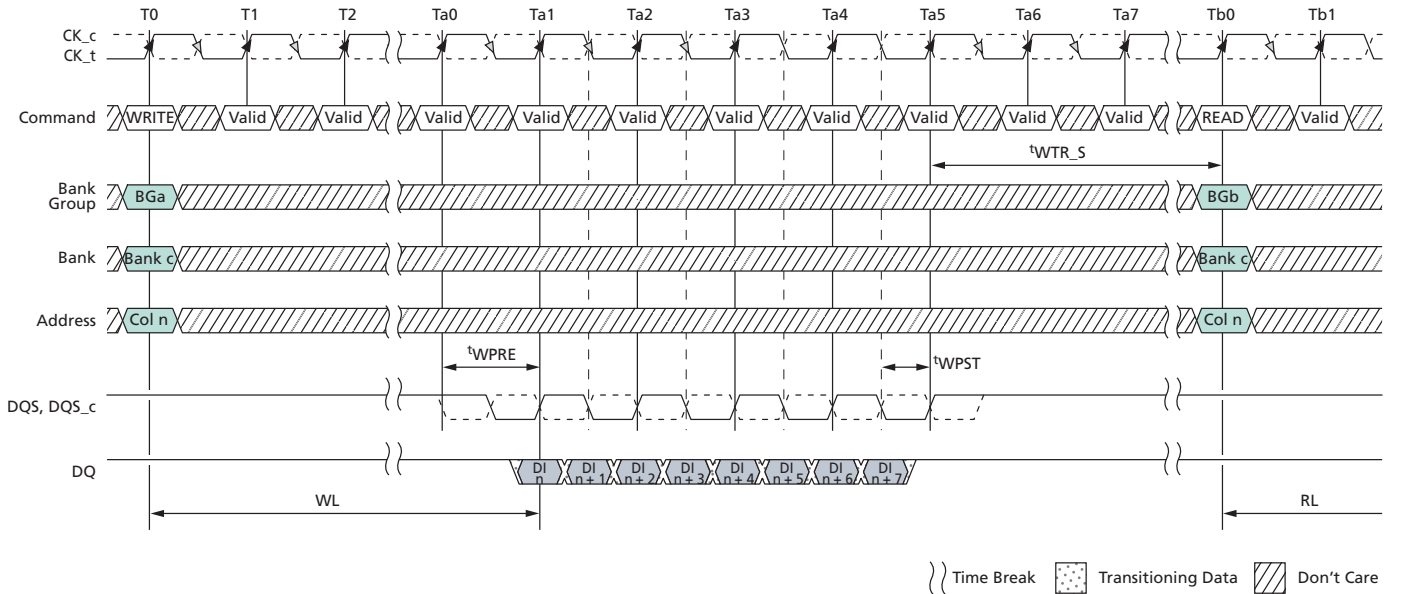
- Notes:
1.  $t^{\text{CCD}}_{\text{S}}$ ; CAS<sub>n</sub>-to-CAS<sub>n</sub> delay (short). Applies to consecutive CAS<sub>n</sub> to different bank groups (T0 to T4).
  2.  $t^{\text{CCD}}_{\text{L}}$ ; CAS<sub>n</sub>-to-CAS<sub>n</sub> delay (long). Applies to consecutive CAS<sub>n</sub> to the same bank group (T4 to T10).

**Figure 113:  $t_{RRD}$  Timing**



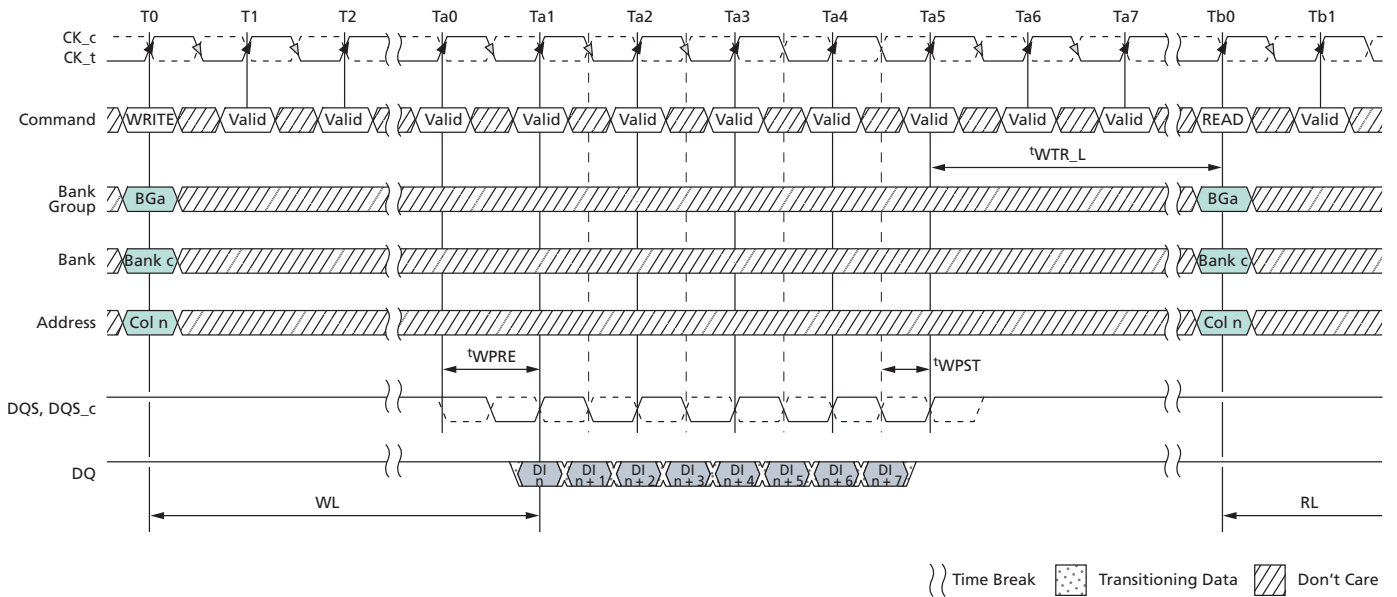
- Notes:
1.  $t_{RRD\_S}$ ; ACTIVATE-to-ACTIVATE command period (short); applies to consecutive ACTIVATE commands to different bank groups (T0 and T4).
  2.  $t_{RRD\_L}$ ; ACTIVATE-to-ACTIVATE command period (long); applies to consecutive ACTIVATE commands to the different banks in the same bank group (T4 and T10).

**Figure 114:  $t_{WTR\_S}$  Timing (WRITE-to-READ, Different Bank Group, CRC and DM Disabled)**



- Note:
1.  $t_{WTR\_S}$ : delay from start of internal write transaction to internal READ command to a different bank group.

**Figure 115:  $t_{WTR\_L}$  Timing (WRITE-to-READ, Same Bank Group, CRC and DM Disabled)**



Note: 1.  $t_{WTR\_L}$ : delay from start of internal write transaction to internal READ command to the same bank group.

## READ Operation

### Read Timing Definitions

The read timings shown below are applicable in normal operation mode, that is, when the DLL is enabled and locked.

**Note:**  $t_{DQSQ}$  = both rising/falling edges of DQS; no  $t_{AC}$  defined.

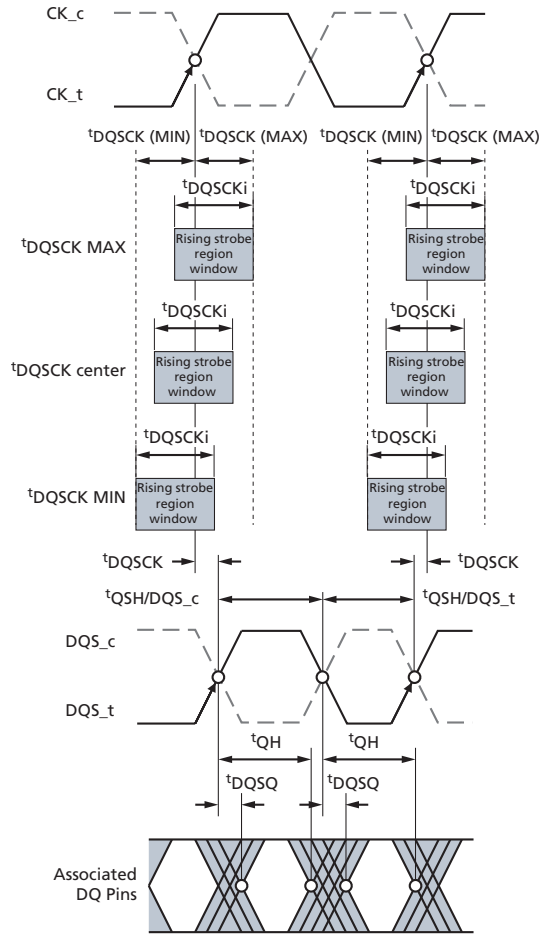
Rising data strobe edge parameters:

- $t_{DQSCK} (MIN)/(MAX)$  describes the allowed range for a rising data strobe edge relative to CK.
- $t_{DQSCK}$  is the actual position of a rising strobe edge relative to CK.
- $t_{QSH}$  describes the DQS differential output HIGH time.
- $t_{DQSQ}$  describes the latest valid transition of the associated DQ pins.
- $t_{QH}$  describes the earliest invalid transition of the associated DQ pins.

Falling data strobe edge parameters:

- $t_{QSL}$  describes the DQS differential output LOW time.
- $t_{DQSQ}$  describes the latest valid transition of the associated DQ pins.
- $t_{QH}$  describes the earliest invalid transition of the associated DQ pins.

Figure 116: Read Timing Definition



## Read Timing – Clock-to-Data Strobe Relationship

The clock-to-data strobe relationship shown below is applicable in normal operation mode, that is, when the DLL is enabled and locked.

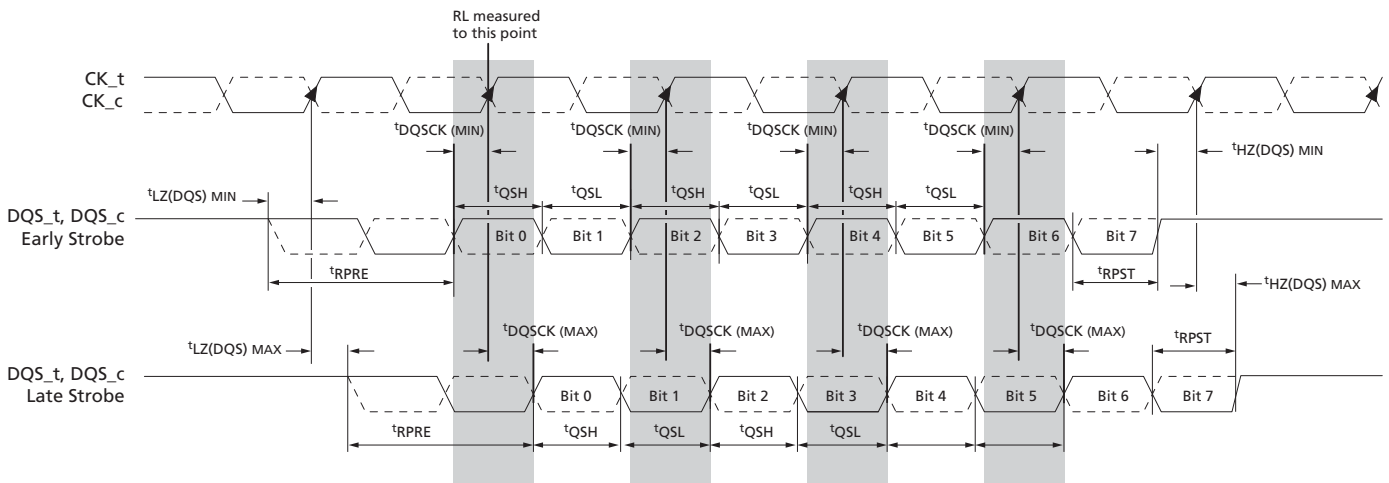
Rising data strobe edge parameters:

- t<sup>DQSK</sup> (MIN) / (MAX) describes the allowed range for a rising data strobe edge relative to CK.
- t<sup>DQSK</sup> is the actual position of a rising strobe edge relative to CK.
- t<sup>QSH</sup> describes the data strobe high pulse width.
- t<sup>HZ(DQS)</sup> DQS strobe going to high, nondrive level (shown in the postamble section of the figure below).

Falling data strobe edge parameters:

- t<sup>QSL</sup> describes the data strobe low pulse width.
- t<sup>LZ(DQS)</sup> DQS strobe going to low, initial drive level (shown in the preamble section of the figure below).

Figure 117: Clock-to-Data Strobe Relationship



Notes: 1. Within a burst, the rising strobe edge will vary within  $t_{DQSKj}$  while at the same voltage and temperature. However, when the device, voltage, and temperature variations are incorporated, the rising strobe edge variance window can shift between  $t_{DQSK} (MIN)$  and  $t_{DQSK} (MAX)$ .

A timing of this window's right edge (latest) from rising  $CK_t, CK_c$  is limited by a device's actual  $t_{DQSK} (MAX)$ . A timing of this window's left inside edge (earliest) from rising  $CK_t, CK_c$  is limited by  $t_{DQSK} (MIN)$ .

2. Notwithstanding Note 1, a rising strobe edge with  $t_{DQSK} (MAX)$  at  $T(n)$  can not be immediately followed by a rising strobe edge with  $t_{DQSK} (MIN)$  at  $T(n + 1)$  because other timing relationships ( $t_{QSH}, t_{QSL}$ ) exist: if  $t_{DQSK}(n + 1) < 0: t_{DQSK}(n) < 1.0 t_{CK} - (t_{QSH} (MIN) + t_{QSL} (MIN)) - |t_{DQSK}(n + 1)|$ .
3. The  $DQS_t, DQS_c$  differential output HIGH time is defined by  $t_{QSH}$ , and the  $DQS_t, DQS_c$  differential output LOW time is defined by  $t_{QSL}$ .
4.  $t_{LZ}(DQS) MIN$  and  $t_{HZ}(DQS) MIN$  are not tied to  $t_{DQSK} (MIN)$  (early strobe case), and  $t_{LZ}(DQS) MAX$  and  $t_{HZ}(DQS) MAX$  are not tied to  $t_{DQSK} (MAX)$  (late strobe case).
5. The minimum pulse width of READ preamble is defined by  $t_{RPRE} (MIN)$ .
6. The maximum READ postamble is bound by  $t_{DQSK} (MIN)$  plus  $t_{QSH} (MIN)$  on the left side and  $t_{HZDSQ} (MAX)$  on the right side.
7. The minimum pulse width of READ postamble is defined by  $t_{RPST} (MIN)$ .
8. The maximum READ preamble is bound by  $t_{LZDQS} (MIN)$  on the left side and  $t_{DQSK} (MAX)$  on the right side.

### Read Timing – Data Strobe-to-Data Relationship

The data strobe-to-data relationship is shown below and is applied when the DLL is enabled and locked.

Note:  $t_{DQSQ}$ : both rising/falling edges of DQS; no  $t_{AC}$  defined.

Rising data strobe edge parameters:

- $t_{DQSQ}$  describes the latest valid transition of the associated DQ pins.
- $t_{QH}$  describes the earliest invalid transition of the associated DQ pins.

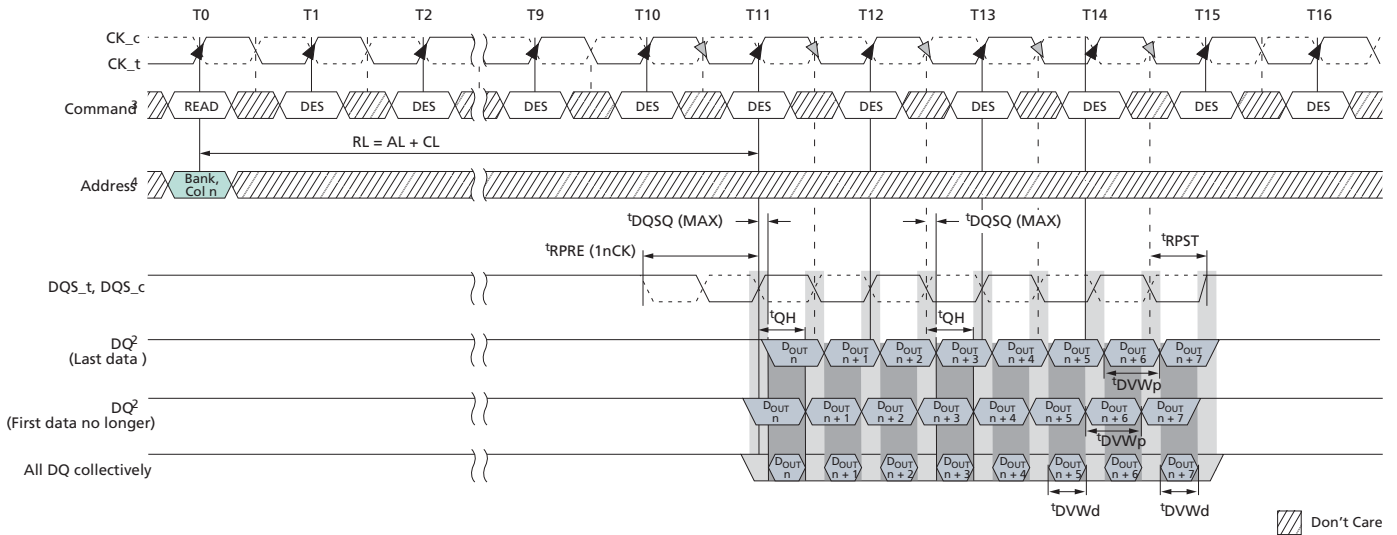
Falling data strobe edge parameters:

- $t_{DQSQ}$  describes the latest valid transition of the associated DQ pins.
- $t_{QH}$  describes the earliest invalid transition of the associated DQ pins.

Data valid window parameters:

- $t_{DVWd}$  is the Data Valid Window per device per UI and is derived from  $[t_{QH} - t_{DQSQ}]$  of each UI on a given DRAM
- $t_{DVWp}$  is the Data Valid Window per pin per UI and is derived  $[t_{QH} - t_{DQSQ}]$  of each UI on a pin of a given DRAM

**Figure 118: Data Strobe-to-Data Relationship**

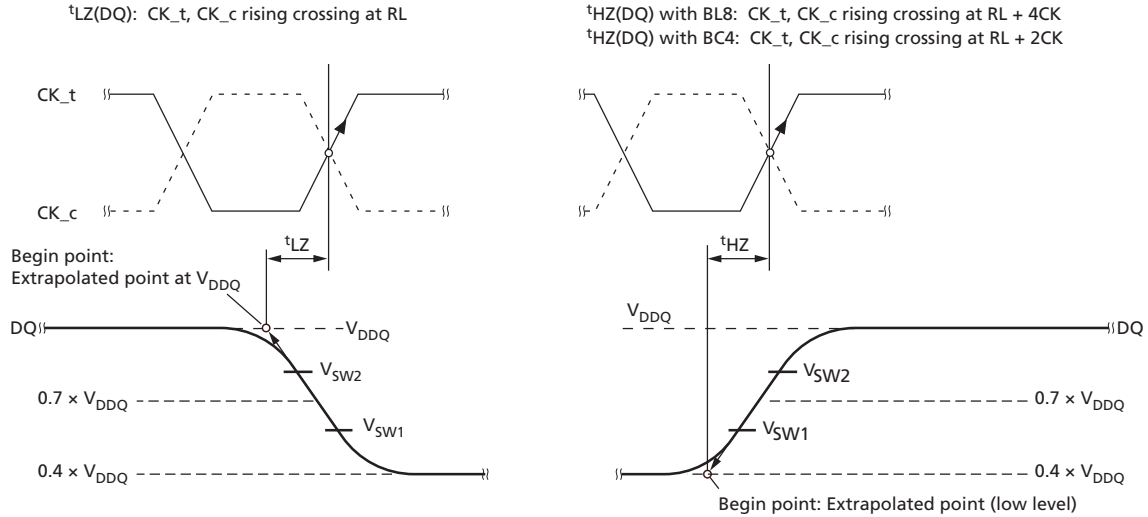


- Notes:
1. BL = 8, RL = 11 (AL = 0, CL = 1), Preamble =  $1t_{CK}$ .
  2.  $D_{OUTn}$  = data-out from column  $n$ .
  3. DES commands are shown for ease of illustration; other commands may be valid at these times.
  4. BL8 setting activated by either  $MR0[A1:0 = 00]$  or  $MR0[A1:0 = 01]$  and  $A12 = 1$  during READ commands at  $T0$ .
  5. Output timings are referenced to  $V_{DDQ}$ , and DLL on for locking.
  6.  $t_{DQSQ}$  defines the skew between DQS to data and does not define DQS to clock.
  7. Early data transitions may not always happen at the same DQ. Data transitions of a DQ can vary (either early or late) within a burst.

**$t_{LZ}(DQS)$ ,  $t_{LZ}(DQ)$ ,  $t_{HZ}(DQS)$ , and  $t_{HZ}(DQ)$  Calculations**

$t_{HZ}$  and  $t_{LZ}$  transitions occur in the same time window as valid data transitions. These parameters are referenced to a specific voltage level that specifies when the device output is no longer driving  $t_{HZ}(DQS)$  and  $t_{HZ}(DQ)$ , or begins driving  $t_{LZ}(DQS)$  and  $t_{LZ}(DQ)$ . The figure below shows a method to calculate the point when the device is no longer driving  $t_{HZ}(DQS)$  and  $t_{HZ}(DQ)$ , or begins driving  $t_{LZ}(DQS)$  and  $t_{LZ}(DQ)$ , by measuring the signal at two different voltages. The actual voltage measurement points are not critical as long as the calculation is consistent.  $t_{LZ}(DQS)$ ,  $t_{LZ}(DQ)$ ,  $t_{HZ}(DQS)$ , and  $t_{HZ}(DQ)$  are defined as singled-ended parameters.

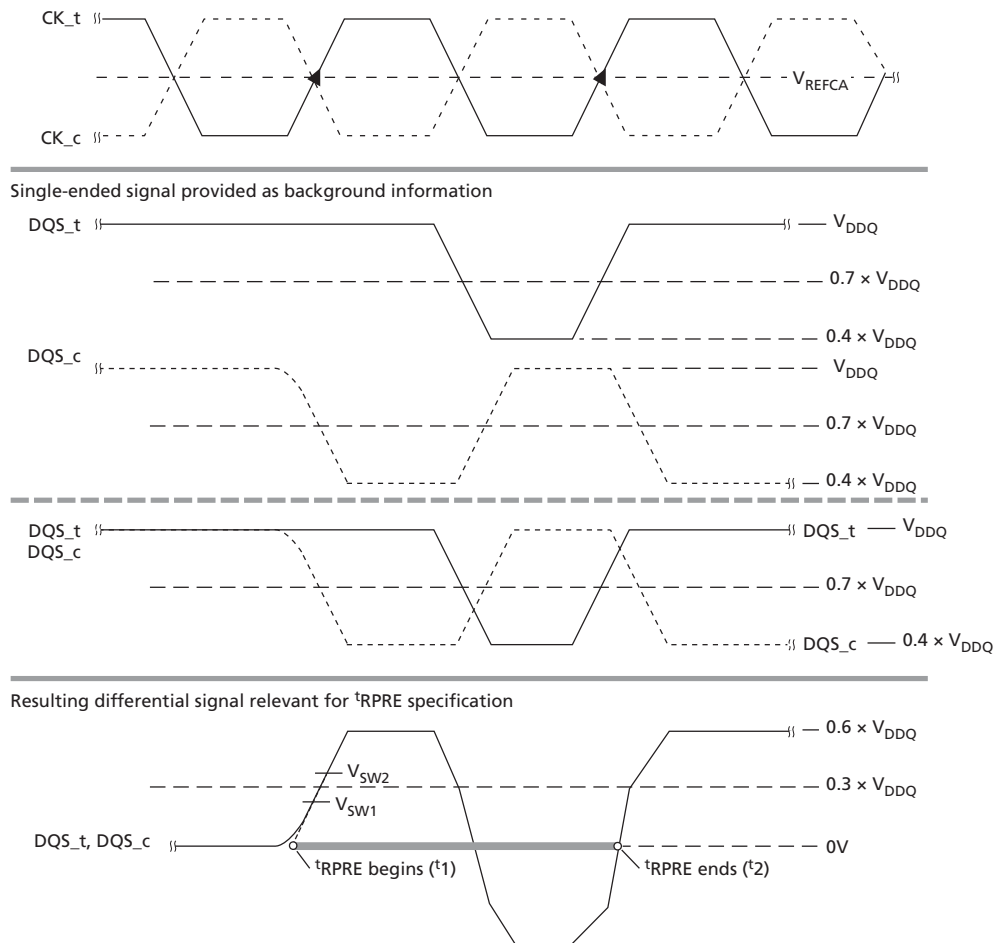
Figure 119:  $t_{LZ}$  and  $t_{HZ}$  Method for Calculating Transitions and Endpoints



- Notes:
- $V_{sw1} = (0.70 - 0.04) \times V_{DDQ}$  for both  $t_{LZ}$  and  $t_{HZ}$ .
  - $V_{sw2} = (0.70 + 0.04) \times V_{DDQ}$  for both  $t_{LZ}$  and  $t_{HZ}$ .
  - Extrapolated point (low level) =  $V_{DDQ}/(50 + 34) \times 34 = 0.4 \times V_{DDQ}$   
 Driver impedance =  $RZQ/7 = 34\Omega$   
 $V_{TT}$  test load =  $50\Omega$  to  $V_{DDQ}$ .

## $t_{\text{RPRE}}$ Calculation

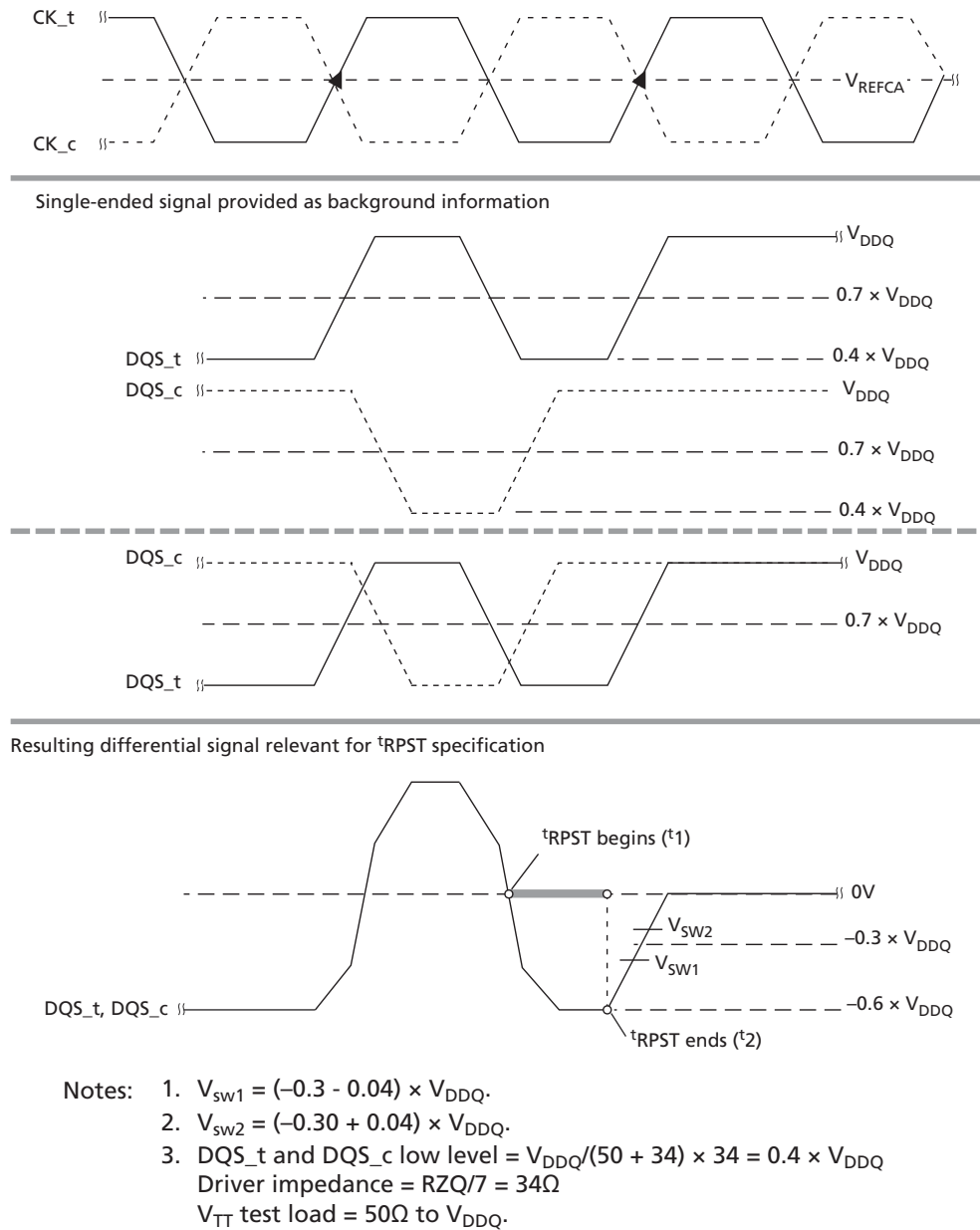
Figure 120:  $t_{\text{RPRE}}$  Method for Calculating Transitions and Endpoints



- Notes:
- $V_{\text{sw1}} = (0.3 - 0.04) \times V_{\text{DDQ}}$ .
  - $V_{\text{sw2}} = (0.30 + 0.04) \times V_{\text{DDQ}}$ .
  - $DQS_t$  and  $DQS_c$  low level =  $V_{\text{DDQ}} / (50 + 34) \times 34 = 0.4 \times V_{\text{DDQ}}$   
Driver impedance =  $RZQ / 7 = 34\Omega$   
 $V_{\text{TT}}$  test load =  $50\Omega$  to  $V_{\text{DDQ}}$ .

## t<sub>RPST</sub> Calculation

Figure 121: t<sub>RPST</sub> Method for Calculating Transitions and Endpoints



### READ Burst Operation

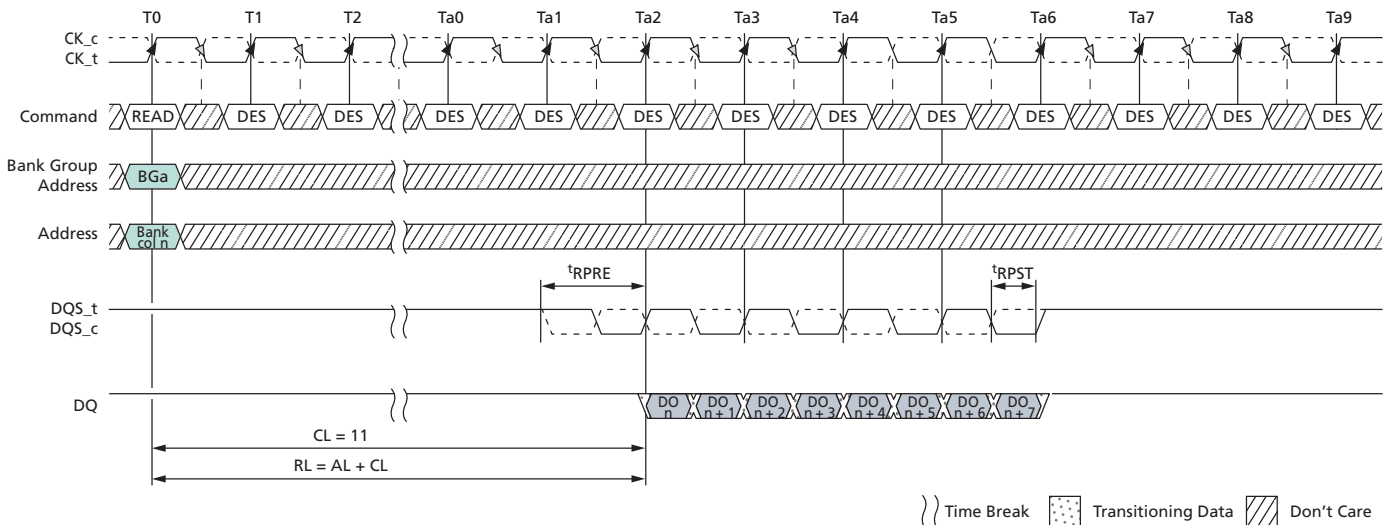
DDR4 READ commands support bursts of BL8 (fixed), BC4 (fixed), and BL8/BC4 on-the-fly (OTF); OTF uses address A12 to control OTF when OTF is enabled:

- A12 = 0, BC4 (BC4 = burst chop)
- A12 = 1, BL8

READ commands can issue precharge automatically with a READ with auto precharge command (RDA), and is enabled by A10 HIGH:

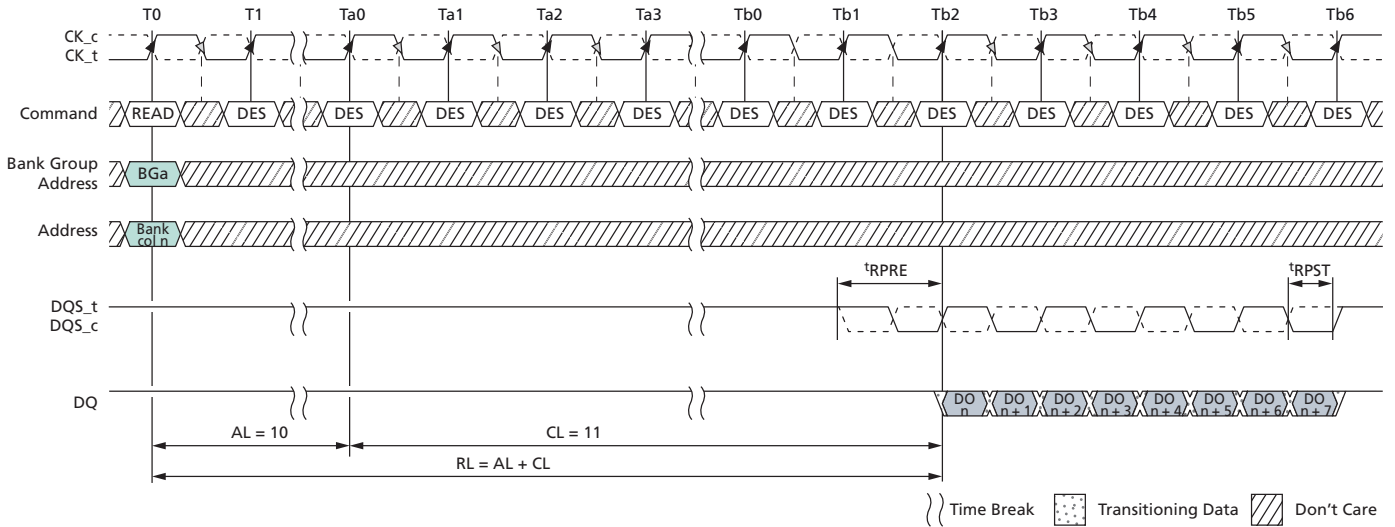
- READ command with A10 = 0 (RD) performs standard read, bank remains active after READ burst.
- READ command with A10 = 1 (RDA) performs read with auto precharge, bank goes in to precharge after READ burst.

**Figure 122: READ Burst Operation, RL = 11 (AL = 0, CL = 11, BL8)**



- Notes:
1. BL8, RL = 0, AL = 0, CL = 11, Preamble = 1<sup>t</sup>CK.
  2. DO *n* = data-out from column *n*.
  3. DES commands are shown for ease of illustration; other commands may be valid at these times.
  4. BL8 setting activated by either MR0[1:0] = 00 or MR0[1:0] = 01 and A12 = 1 during READ command at T0.
  5. CA parity = Disable, CS to CA latency = Disable, Read DBI = Disable.

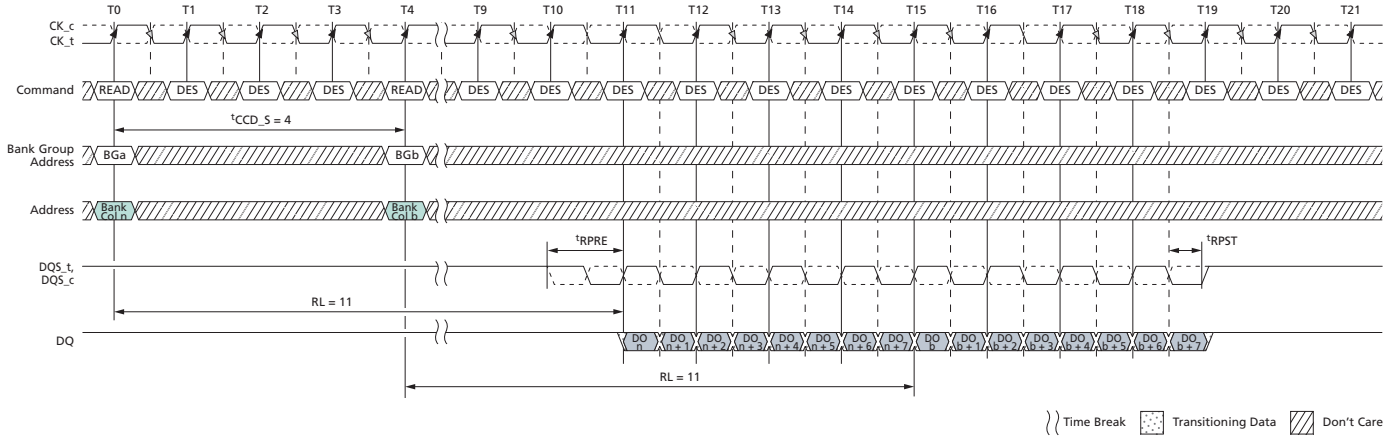
Figure 123: READ Burst Operation, RL = 21 (AL = 10, CL = 11, BL8)



- Notes:
1. BL8, RL = 21, AL = (CL - 1), CL = 11, Preamble = 1<sup>t</sup>CK.
  2. DO *n* = data-out from column *n*.
  3. DES commands are shown for ease of illustration; other commands may be valid at these times.
  4. BL8 setting activated by either MR0[1:0] = 00 or MR0[1:0] = 01 and A12 = 1 during READ command at T0.
  5. CA parity = Disable, CS to CA latency = Disable, Read DBI = Disable.

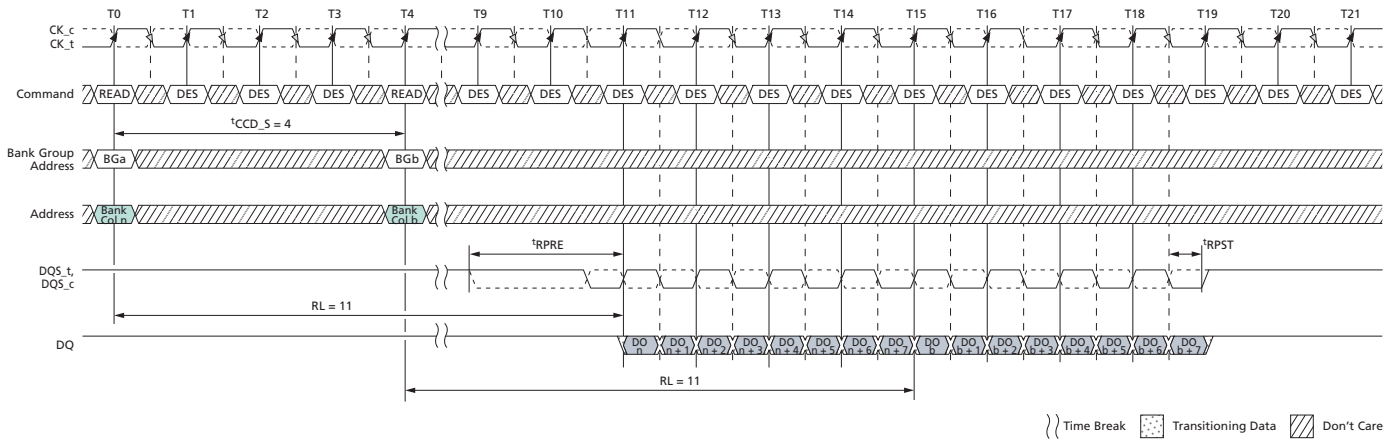
## READ Operation Followed by Another READ Operation

Figure 124: Consecutive READ (BL8) with 1<sup>t</sup>CK Preamble in Different Bank Group



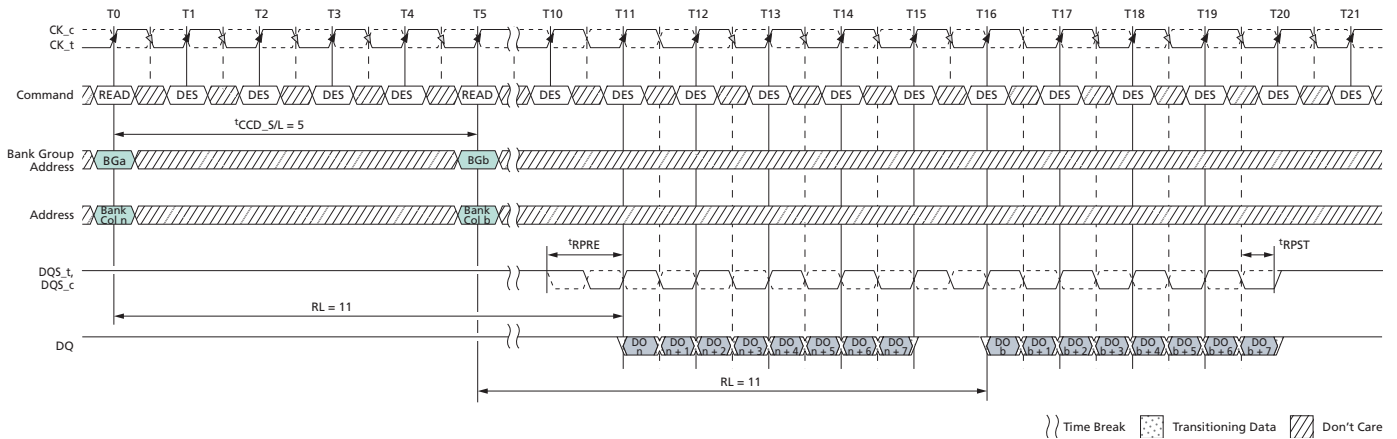
- Notes:
1. BL8, AL = 0, CL = 11, Preamble = 1<sup>t</sup>CK.
  2. DO *n* (or *b*) = data-out from column *n* (or column *b*).
  3. DES commands are shown for ease of illustration; other commands may be valid at these times.
  4. BL8 setting activated by either MR0[1:0] = 00 or MR0[1:0] = 01 and A12 = 1 during READ commands at T0 and T4.
  5. CA parity = Disable, CS to CA latency = Disable, Read DBI = Disable.

Figure 125: Consecutive READ (BL8) with 2<sup>t</sup>CK Preamble in Different Bank Group



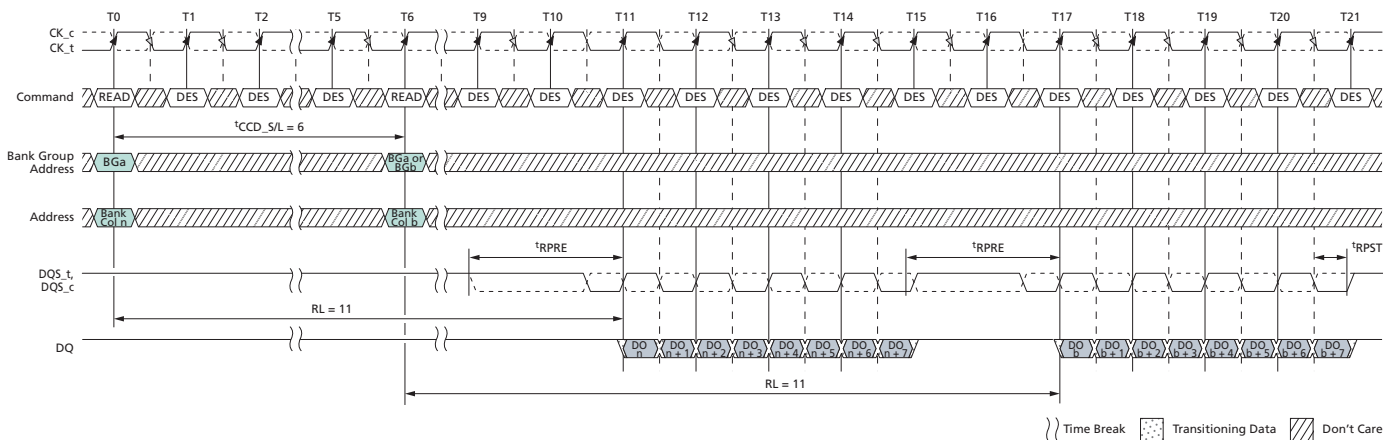
- Notes:
1. BL8, AL = 0, CL = 11, Preamble = 2<sup>t</sup>CK.
  2. DO *n* (or *b*) = data-out from column *n* (or column *b*).
  3. DES commands are shown for ease of illustration; other commands may be valid at these times.
  4. BL8 setting activated by either MR0[1:0] = 00 or MR0[1:0] = 01 and A12 = 1 during READ commands at T0 and T4.
  5. CA parity = Disable, CS to CA latency = Disable, Read DBI = Disable.

**Figure 126: Nonconsecutive READ (BL8) with 1<sup>t</sup>CK Preamble in Same or Different Bank Group**



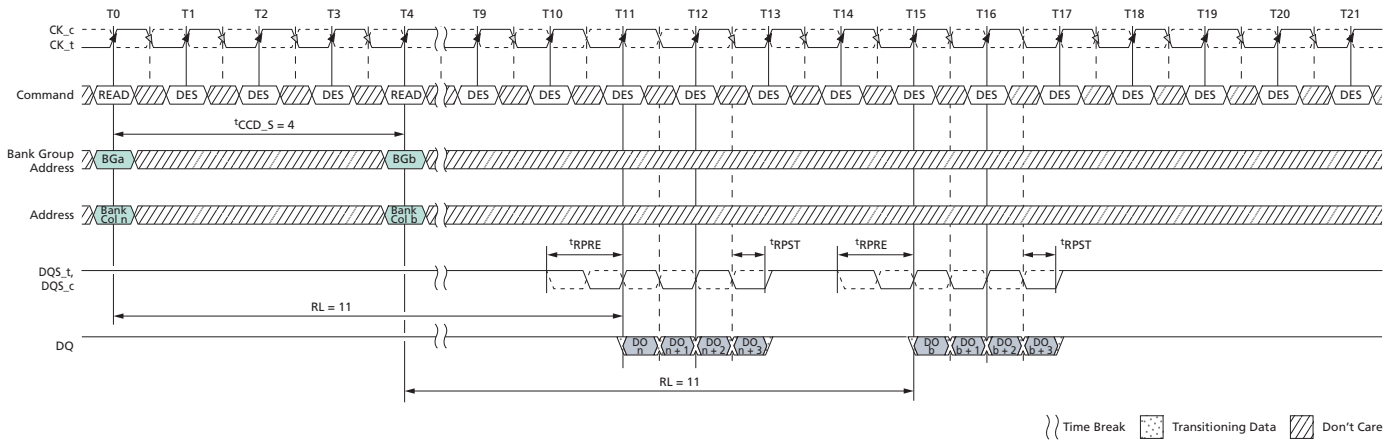
- Notes:
1. BL8, AL = 0, CL = 11, Preamble = 1<sup>t</sup>CK, t<sup>CCD\_S/L</sup> = 5.
  2. DO *n* (or *b*) = data-out from column *n* (or column *b*).
  3. DES commands are shown for ease of illustration; other commands may be valid at these times.
  4. BL8 setting activated by either MR0[1:0] = 00 or MR0[1:0] = 01 and A12 = 1 during READ commands at T0 and T5.
  5. CA parity = Disable, CS to CA latency = Disable, Read DBI = Disable.

**Figure 127: Nonconsecutive READ (BL8) with 2<sup>t</sup>CK Preamble in Same or Different Bank Group**



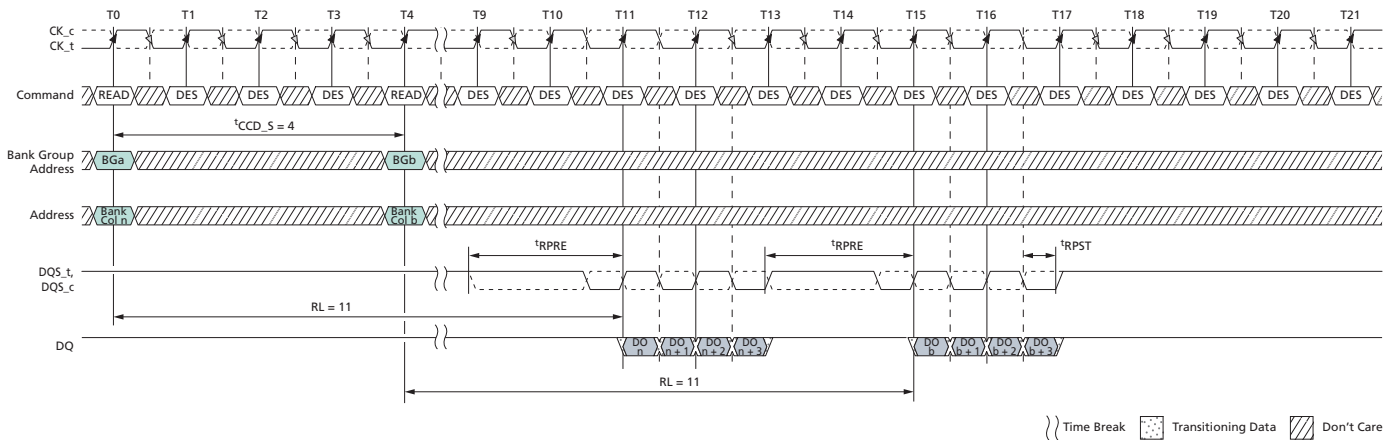
- Notes:
1. BL8, AL = 0, CL = 11, Preamble = 2<sup>t</sup>CK, t<sup>CCD\_S/L</sup> = 6.
  2. DO *n* (or *b*) = data-out from column *n* (or column *b*).
  3. DES commands are shown for ease of illustration; other commands may be valid at these times.
  4. BL8 setting activated by either MR0[A1:0] = 00 or MR0[A1:0] = 01 and A12 = 1 during READ commands at T0 and T6.
  5. CA parity = Disable, CS to CA latency = Disable, Read DBI = Disable.
  6. 6 t<sup>CCD\_S/L</sup> = 5 isn't allowed in 2<sup>t</sup>CK preamble mode.

**Figure 128: READ (BC4) to READ (BC4) with 1<sup>t</sup>CK Preamble in Different Bank Group**



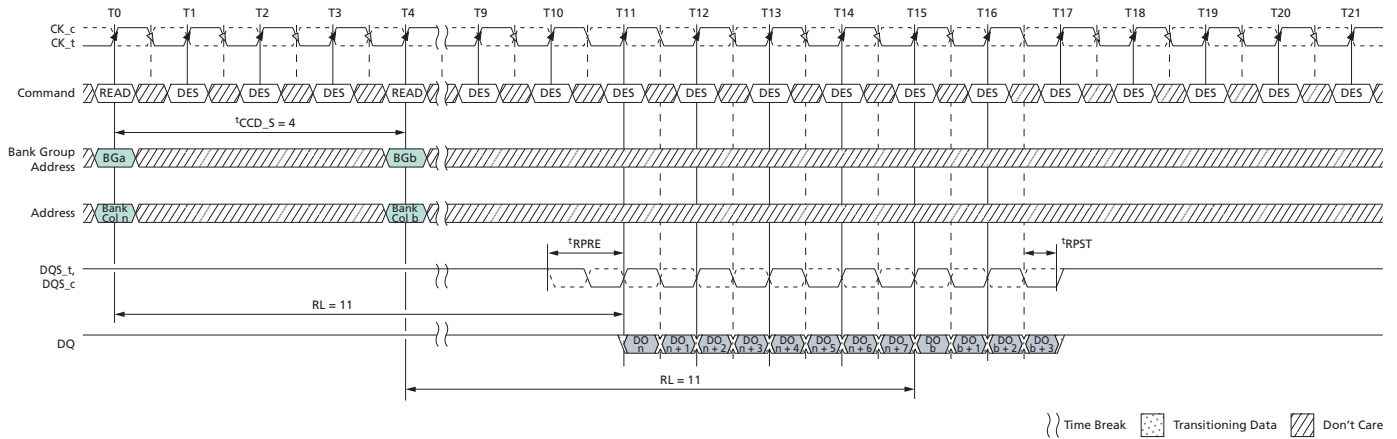
- Notes:
1. BL8, AL = 0, CL = 11, Preamble = 1<sup>t</sup>CK.
  2. DO *n* (or *b*) = data-out from column *n* (or column *b*).
  3. DES commands are shown for ease of illustration; other commands may be valid at these times.
  4. BC4 setting activated by either MR0[1:0] = 10 or MR0[1:0] = 01 and A12 = 0 during READ commands at T0 and T4.
  5. CA parity = Disable, CS to CA latency = Disable, Read DBI = Disable.

**Figure 129: READ (BC4) to READ (BC4) with 2<sup>t</sup>CK Preamble in Different Bank Group**



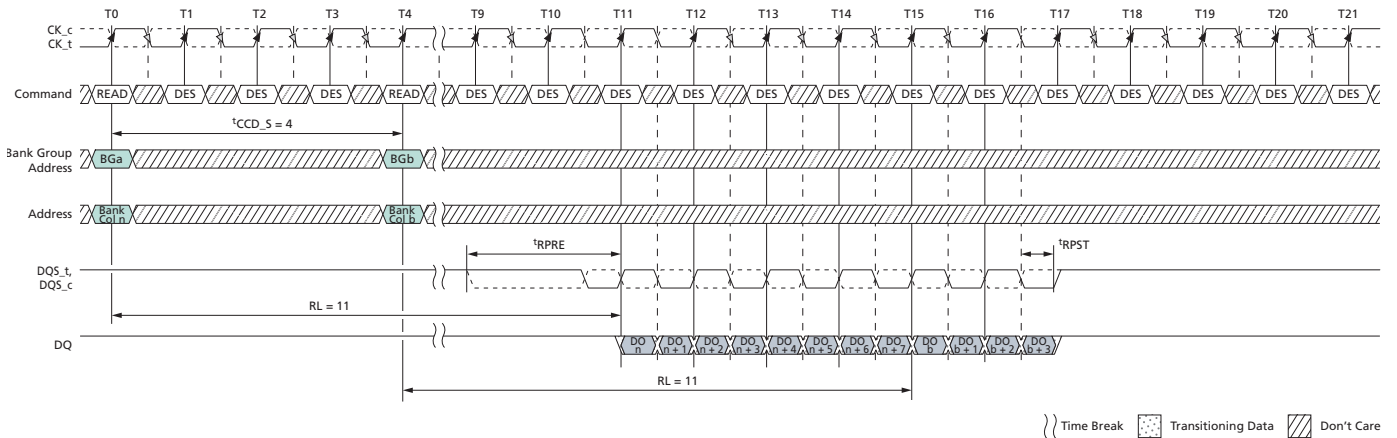
- Notes:
1. BL8, AL = 0, CL = 11, Preamble = 2<sup>t</sup>CK.
  2. DO *n* (or *b*) = data-out from column *n* (or column *b*).
  3. DES commands are shown for ease of illustration; other commands may be valid at these times.
  4. BC4 setting activated by either MR0[1:0] = 10 or MR0[1:0] = 01 and A12 = 0 during READ commands at T0 and T4.
  5. CA parity = Disable, CS to CA latency = Disable, Read DBI = Disable.

Figure 130: READ (BL8) to READ (BC4) OTF with 1<sup>t</sup>CK Preamble in Different Bank Group



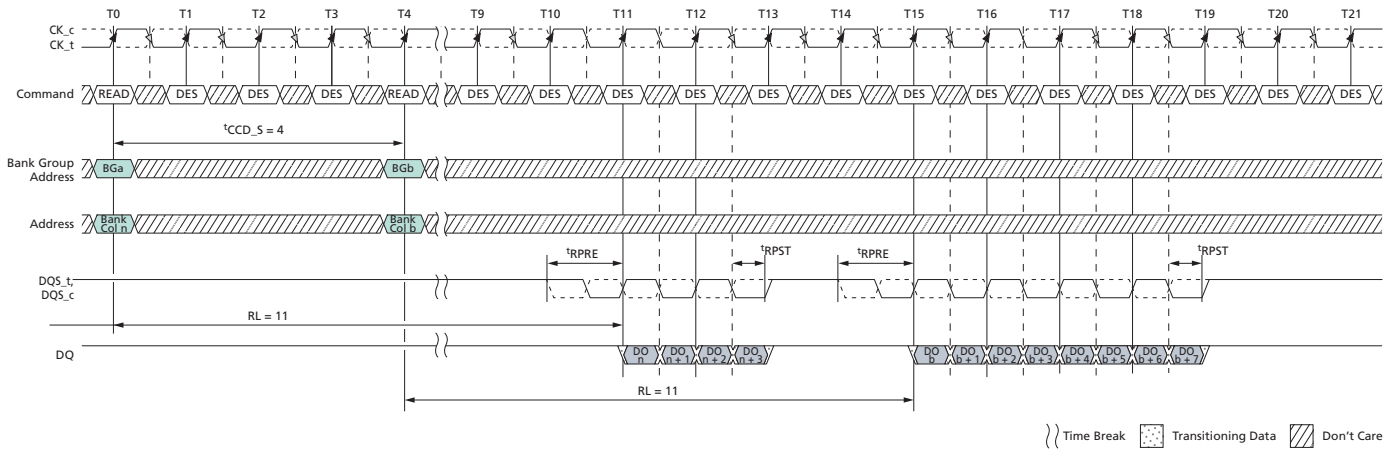
- Notes:
1. BL = 8, AL = 0, CL = 11, Preamble = 1<sup>t</sup>CK.
  2. DO *n* (or *b*) = data-out from column *n* (or column *b*).
  3. DES commands are shown for ease of illustration; other commands may be valid at these times.
  4. BL8 setting activated by MR0[1:0] = 01 and A12 = 1 during READ commands at T0. BC4 setting activated by MR0[1:0] = 01 and A12 = 0 during READ commands at T4.
  5. CA parity = Disable, CS to CA latency = Disable, Read DBI = Disable.

Figure 131: READ (BL8) to READ (BC4) OTF with 2<sup>t</sup>CK Preamble in Different Bank Group



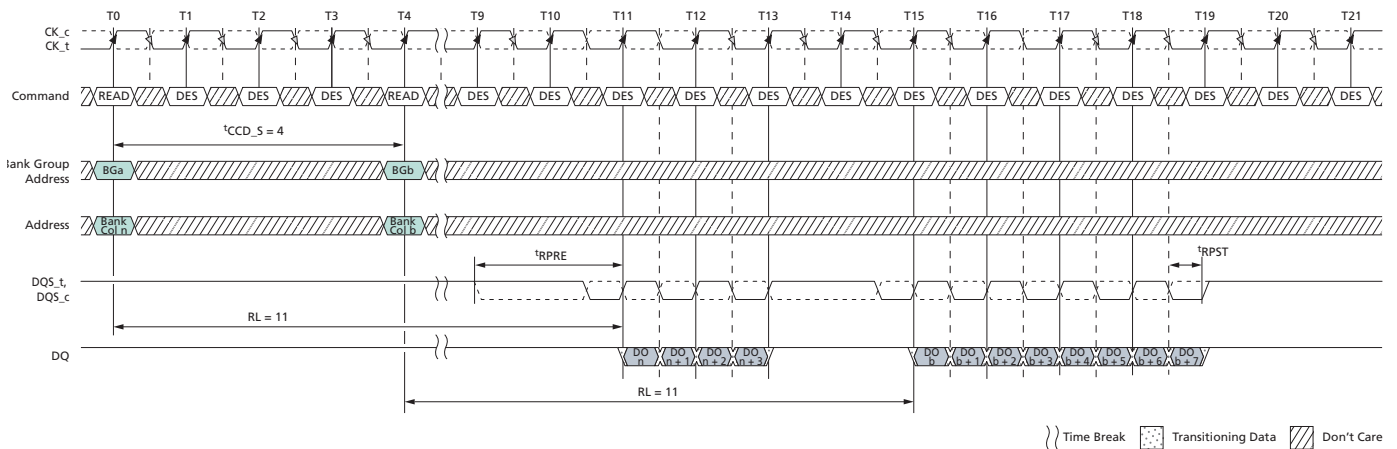
- Notes:
1. BL = 8, AL = 0, CL = 11, Preamble = 2<sup>t</sup>CK.
  2. DO *n* (or *b*) = data-out from column *n* (or column *b*).
  3. DES commands are shown for ease of illustration; other commands may be valid at these times.
  4. BL8 setting activated by MR0[1:0] = 01 and A12 = 1 during READ commands at T0. BC4 setting activated by MR0[1:0] = 01 and A12 = 0 during READ commands at T4.
  5. CA parity = Disable, CS to CA latency = Disable, Read DBI = Disable.

**Figure 132: READ (BC4) to READ (BL8) OTF with 1<sup>t</sup>CK Preamble in Different Bank Group**



- Notes:
1. BL = 8, AL = 0, CL = 11, Preamble = 1<sup>t</sup>CK.
  2. DO *n* (or *b*) = data-out from column *n* (or column *b*).
  3. DES commands are shown for ease of illustration; other commands may be valid at these times.
  4. BC4 setting activated by MR0[1:0] = 01 and A12 = 0 during READ commands at T0. BL8 setting activated by MR0[1:0] = 01 and A12 = 1 during READ commands at T4.
  5. CA parity = Disable, CS to CA latency = Disable, Read DBI = Disable.

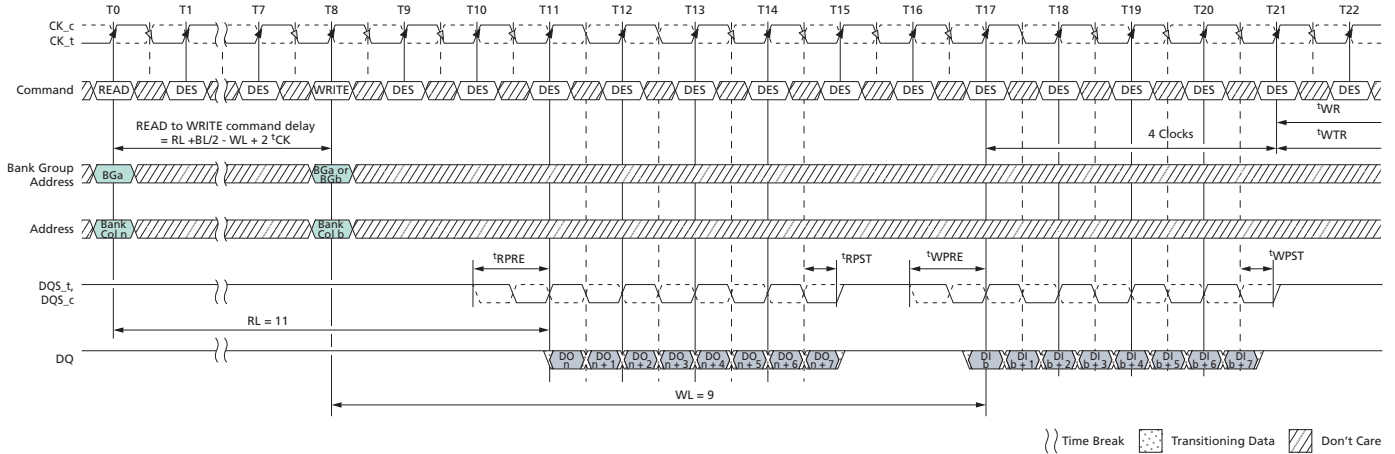
**Figure 133: READ (BC4) to READ (BL8) OTF with 2<sup>t</sup>CK Preamble in Different Bank Group**



- Notes:
1. BL = 8, AL = 0, CL = 11, Preamble = 2<sup>t</sup>CK.
  2. DO *n* (or *b*) = data-out from column *n* (or column *b*).
  3. DES commands are shown for ease of illustration; other commands may be valid at these times.
  4. BC4 setting activated by MR0[1:0] = 01 and A12 = 0 during READ commands at T0. BL8 setting activated by MR0[1:0] = 01 and A12 = 1 during READ commands at T4.
  5. CA parity = Disable, CS to CA latency = Disable, Read DBI = Disable.

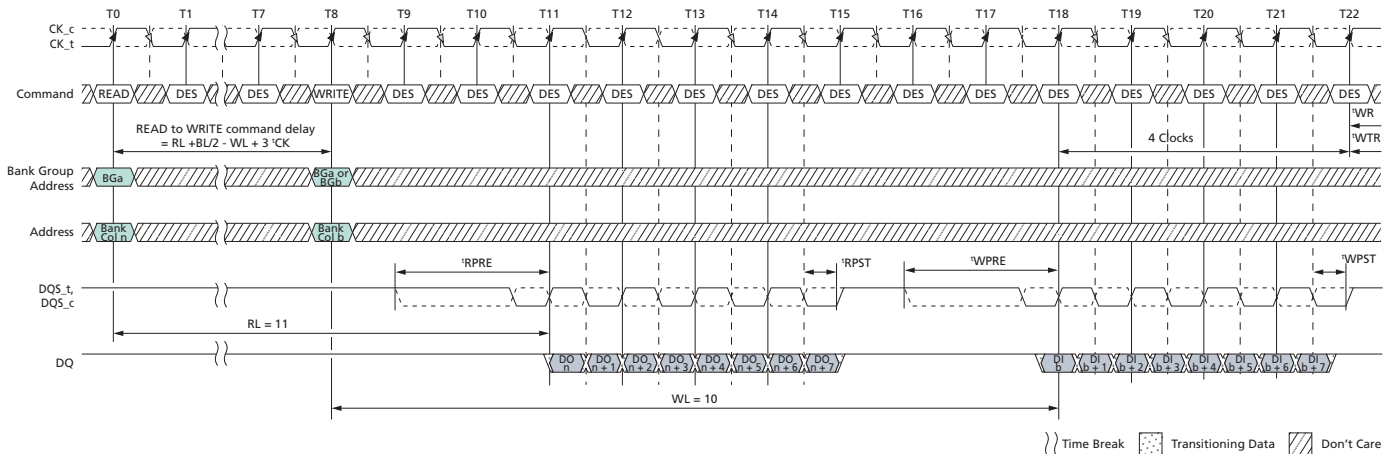
## READ Operation Followed by WRITE Operation

Figure 134: READ (BL8) to WRITE (BL8) with 1<sup>t</sup>CK Preamble in Same or Different Bank Group



- Notes:
1. BL = 8, RL = 11 (CL = 11, AL = 0), READ preamble = 1<sup>t</sup>CK, WL = 9 (CWL = 9, AL = 0), WRITE preamble = 1<sup>t</sup>CK.
  2. DO *n* = data-out from column *n*; DI *b* = data-in from column *b*.
  3. DES commands are shown for ease of illustration; other commands may be valid at these times.
  4. BL8 setting activated by either MR0[1:0] = 00 or MR0[1:0] = 01 and A12 = 1 during READ commands at T0 and WRITE commands at T8.
  5. CA parity = Disable, CS to CA latency = Disable, Read DBI = Disable, Write DBI = Disable, Write CRC = Disable.

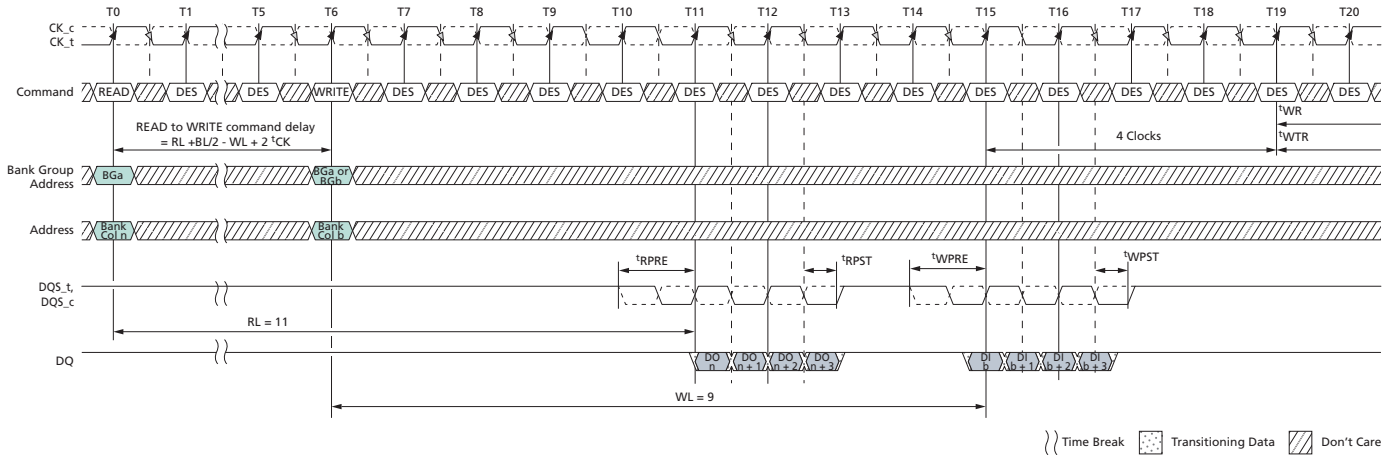
Figure 135: READ (BL8) to WRITE (BL8) with 2<sup>t</sup>CK Preamble in Same or Different Bank Group



- Notes:
1. BL = 8, RL = 11 (CL = 11, AL = 0), READ preamble = 2<sup>t</sup>CK, WL = 10 (CWL = 9+1 [see Note 5], AL = 0), WRITE preamble = 2<sup>t</sup>CK.
  2. DO *n* = data-out from column *n*; DI *b* = data-in from column *b*.
  3. DES commands are shown for ease of illustration; other commands may be valid at these times.

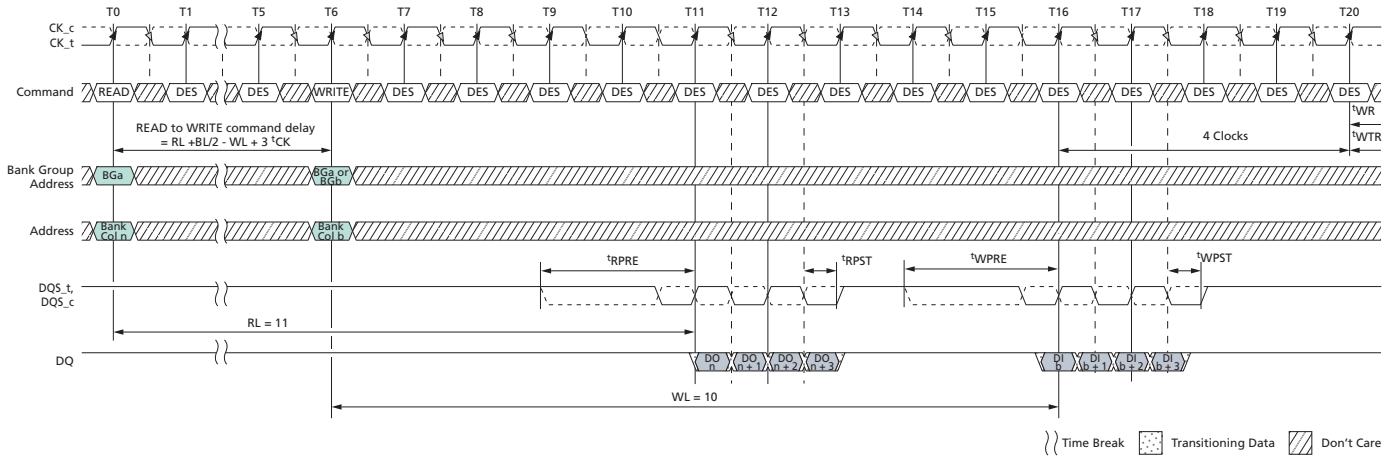
4. BL8 setting activated by either MR0[1:0] = 00 or MR0[1:0] = 01 and A12 = 1 during READ commands at T0 and WRITE commands at T8.
5. When operating in 2<sup>t</sup>CK WRITE preamble mode, CWL may need to be programmed to a value at least 1 clock greater than the lowest CWL setting.
6. CA parity = Disable, CS to CA latency = Disable, Read DBI = Disable, Write DBI = Disable, Write CRC = Disable.

**Figure 136: READ (BC4) OTF to WRITE (BC4) OTF with 1<sup>t</sup>CK Preamble in Same or Different Bank Group**



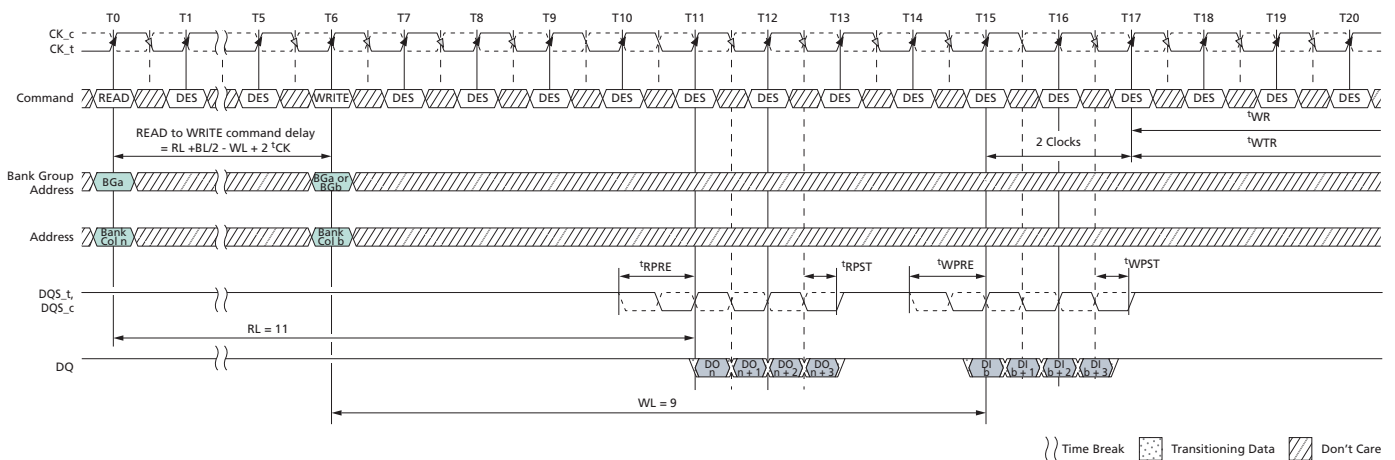
- Notes:
1. BC = 4, RL = 11 (CL = 11, AL = 0), READ preamble = 1<sup>t</sup>CK, WL = 9 (CWL = 9, AL = 0), WRITE preamble = 1<sup>t</sup>CK.
  2. DO *n* = data-out from column *n*; DI *b* = data-in from column *b*.
  3. DES commands are shown for ease of illustration; other commands may be valid at these times.
  4. BC4 (OTF) setting activated by MR0[1:0] = 01 and A12 = 0 during READ commands at T0 and WRITE commands at T6.
  5. CA parity = Disable, CS to CA latency = Disable, Read DBI = Disable, Write DBI = Disable, Write CRC = Disable.

**Figure 137: READ (BC4) OTF to WRITE (BC4) OTF with 2<sup>t</sup>CK Preamble in Same or Different Bank Group**



- Notes:
1. BC = 4, RL = 11 (CL = 11, AL = 0), READ preamble = 2<sup>t</sup>CK, WL = 10 (CWL = 9 + 1 [see Note 5], AL = 0), WRITE preamble = 2<sup>t</sup>CK.
  2. DO *n* = data-out from column *n*; DI *b* = data-in from column *b*.
  3. DES commands are shown for ease of illustration; other commands may be valid at these times.
  4. BC4 (OTF) setting activated by MR0[1:0] = 01 and A12 = 0 during READ commands at T0 and WRITE commands at T6.
  5. When operating in 2<sup>t</sup>CK WRITE preamble mode, CWL may need to be programmed to a value at least 1 clock greater than the lowest CWL setting.
  6. CA parity = Disable, CS to CA latency = Disable, Read DBI = Disable, Write DBI = Disable, Write CRC = Disable.

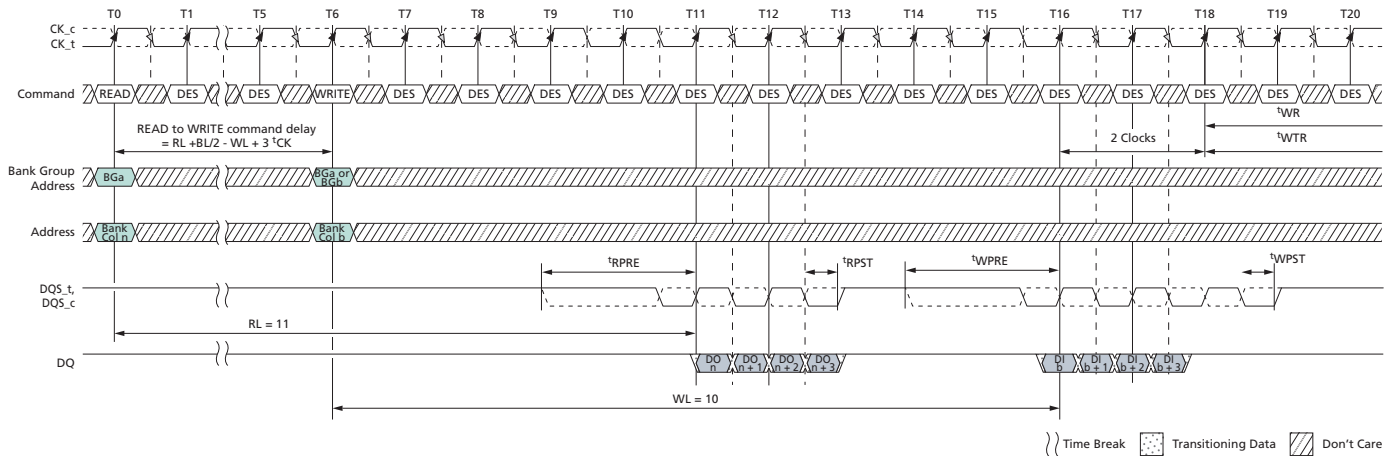
**Figure 138: READ (BC4) Fixed to WRITE (BC4) Fixed with 1<sup>t</sup>CK Preamble in Same or Different Bank Group**



- Notes:
1. BC = 4, RL = 11 (CL = 11, AL = 0), READ preamble = 1<sup>t</sup>CK, WL = 9 (CWL = 9, AL = 0), WRITE preamble = 1<sup>t</sup>CK.
  2. DO *n* = data-out from column *n*; DI *b* = data-in from column *b*.

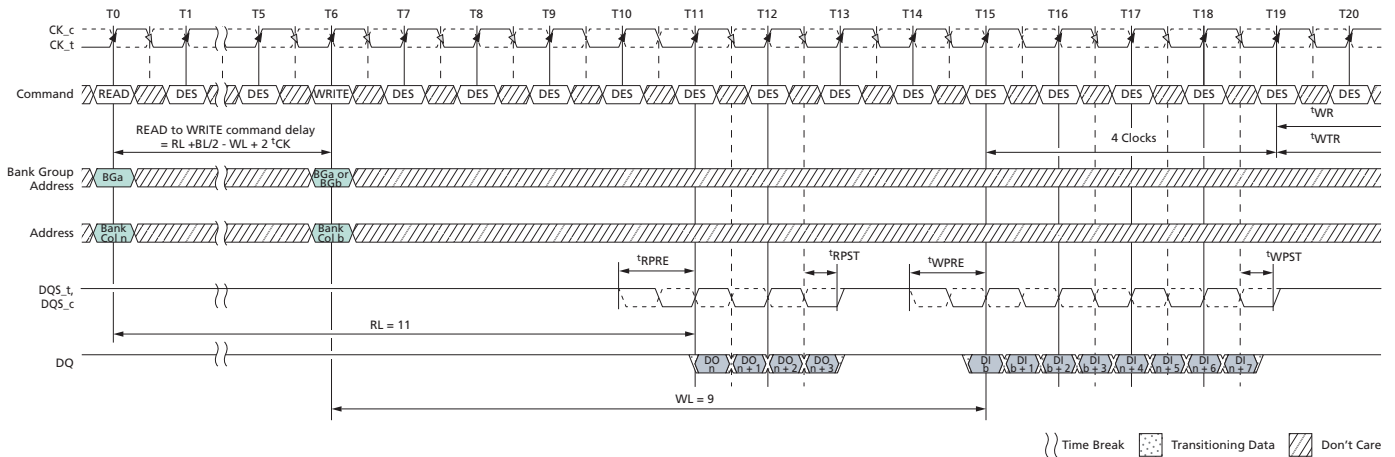
3. DES commands are shown for ease of illustration; other commands may be valid at these times.
4. BC4 (fixed) setting activated by MR0[1:0] = 01.
5. CA parity = Disable, CS to CA latency = Disable, Read DBI = Disable, Write DBI = Disable, Write CRC = Disable.

**Figure 139: READ (BC4) Fixed to WRITE (BC4) Fixed with 2<sup>t</sup>CK Preamble in Same or Different Bank Group**



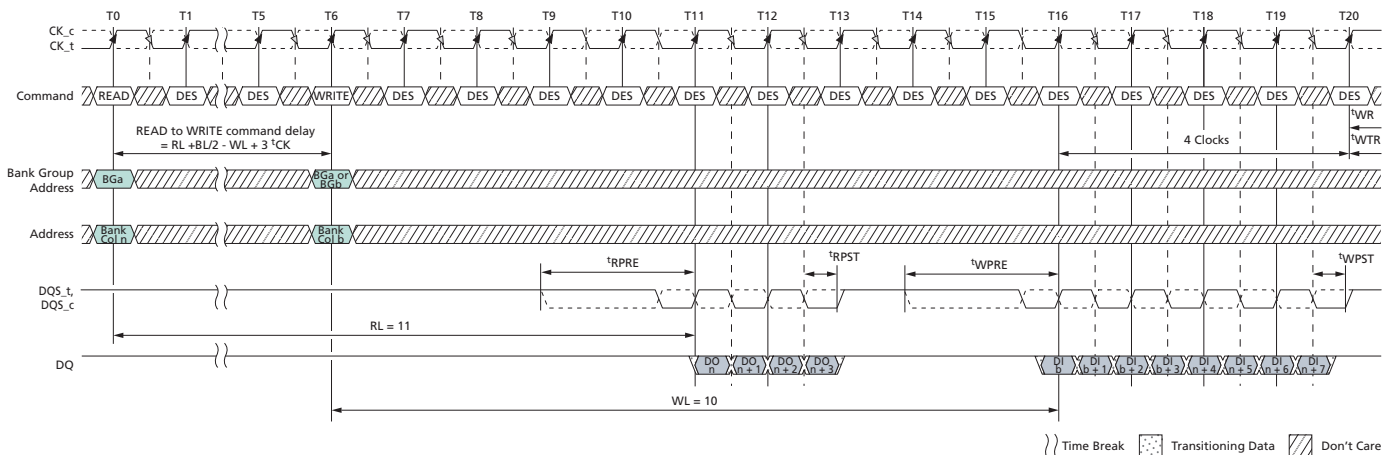
- Notes:
1. BC = 4, RL = 11 (CL = 11, AL = 0), READ preamble = 2<sup>t</sup>CK, WL = 9 (CWL = 9 + 1 [see Note 5], AL = 0), WRITE preamble = 2<sup>t</sup>CK.
  2. DO *n* = data-out from column *n*; DI *b* = data-in from column *b*.
  3. DES commands are shown for ease of illustration; other commands may be valid at these times.
  4. BC4 (fixed) setting activated by MR0[1:0] = 10.
  5. When operating in 2<sup>t</sup>CK WRITE preamble mode, CWL may need to be programmed to a value at least 1 clock greater than the lowest CWL setting.
  6. CA parity = Disable, CS to CA latency = Disable, Read DBI = Disable, Write DBI = Disable, Write CRC = Disable.

**Figure 140: READ (BC4) to WRITE (BL8) OTF with 1<sup>t</sup>CK Preamble in Same or Different Bank Group**



- Notes:
1. BL = 8, RL = 11 (CL = 11, AL = 0), READ preamble = 1<sup>t</sup>CK, WL = 9 (CWL = 9, AL = 0), WRITE preamble = 1<sup>t</sup>CK.
  2. DO *n* = data-out from column *n*; DI *b* = data-in from column *b*.
  3. DES commands are shown for ease of illustration; other commands may be valid at these times.
  4. BC4 setting activated by MR0[1:0] = 01 and A12 = 0 during WRITE commands at T0. BL8 setting activated by MR0[1:0] = 01 and A12 = 1 during READ commands at T6.
  5. CA parity = Disable, CS to CA latency = Disable, Read DBI = Disable, Write DBI = Disable, Write CRC = Disable.

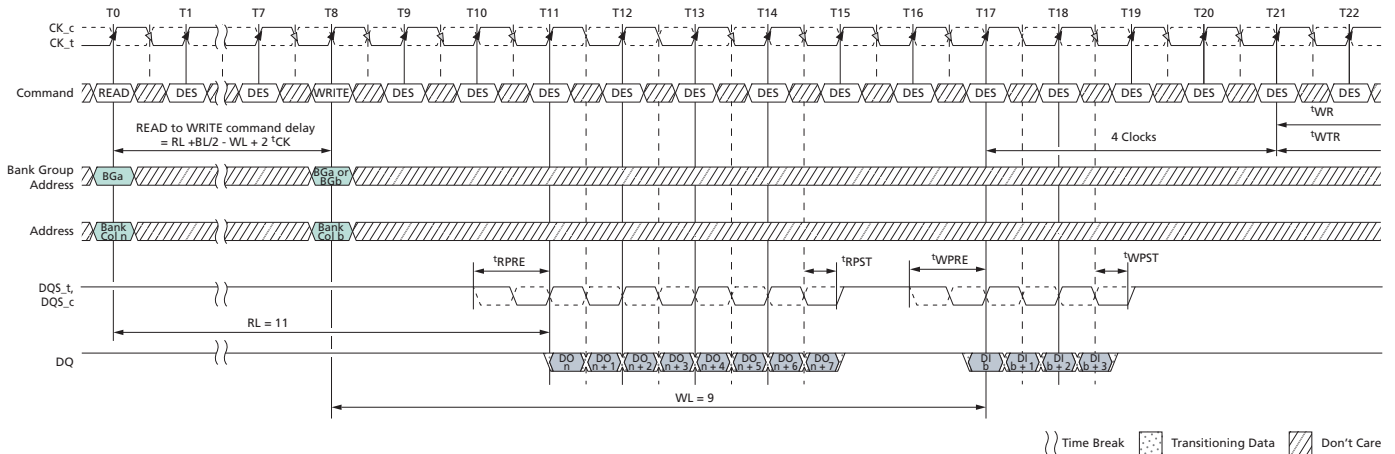
**Figure 141: READ (BC4) to WRITE (BL8) OTF with 2<sup>t</sup>CK Preamble in Same or Different Bank Group**



- Notes:
1. BL = 8, RL = 11 (CL = 11, AL = 0), READ preamble = 2<sup>t</sup>CK, WL = 10 (CWL = 9 + 1 [see Note 5], AL = 0), WRITE preamble = 2<sup>t</sup>CK.
  2. DO *n* = data-out from column *n*; DI *b* = data-in from column *b*.
  3. DES commands are shown for ease of illustration; other commands may be valid at these times.
  4. BC4 setting activated by MR0[1:0] = 01 and A12 = 0 during WRITE commands at T0. BL8 setting activated by MR0[1:0] = 01 and A12 = 1 during READ commands at T6.

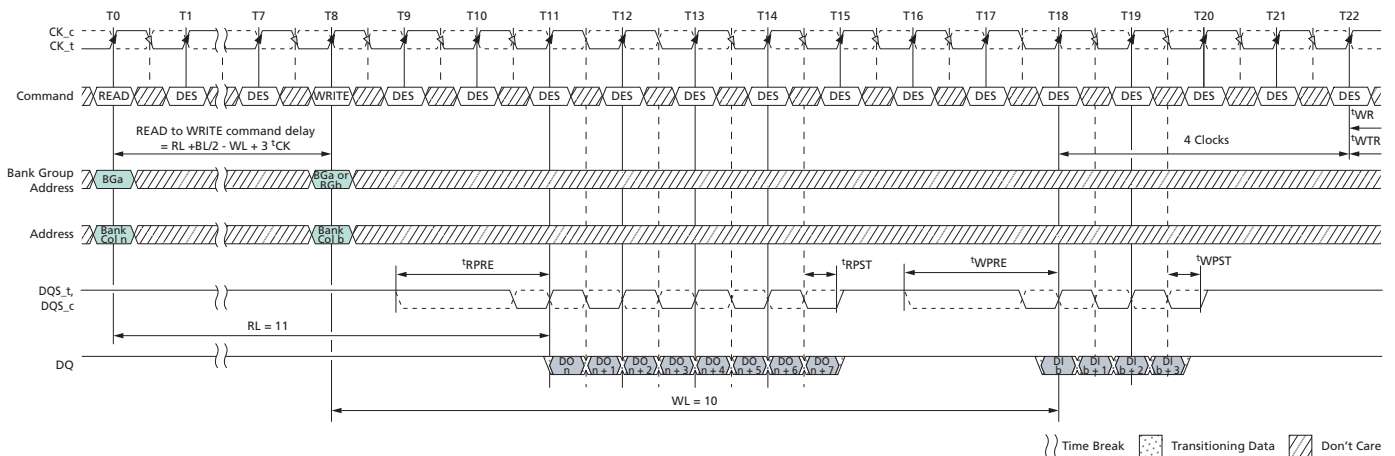
- CA parity = Disable, CS to CA latency = Disable, Read DBI = Disable, Write DBI = Disable, Write CRC = Disable.

**Figure 142: READ (BL8) to WRITE (BC4) OTF with 1<sup>t</sup>CK Preamble in Same or Different Bank Group**



- Notes:
- BL = 8, RL = 11 (CL = 11, AL = 0), READ preamble = 1<sup>t</sup>CK, WL = 9 (CWL = 9, AL = 0), WRITE preamble = 1<sup>t</sup>CK.
  - DO  $n$  = data-out from column  $n$ ; DI  $b$  = data-in from column  $b$ .
  - DES commands are shown for ease of illustration; other commands may be valid at these times.
  - BL8 setting activated by MR0[1:0] = 01 and A12 = 1 during READ commands at T0. BC4 setting activated by MR0[1:0] = 01 and A12 = 0 during WRITE commands at T8.
  - CA parity = Disable, CS to CA latency = Disable, Read DBI = Disable, Write DBI = Disable, Write CRC = Disable.

**Figure 143: READ (BL8) to WRITE (BC4) OTF with 2<sup>t</sup>CK Preamble in Same or Different Bank Group**



- Notes:
- BL = 8, RL = 11 (CL = 11, AL = 0), READ preamble = 2<sup>t</sup>CK, WL = 10 (CWL = 9 + 1 [see Note 5], AL = 0), WRITE preamble = 2<sup>t</sup>CK.
  - DO  $n$  = data-out from column  $n$ ; DI  $b$  = data-in from column  $b$ .
  - DES commands are shown for ease of illustration; other commands may be valid at these times.

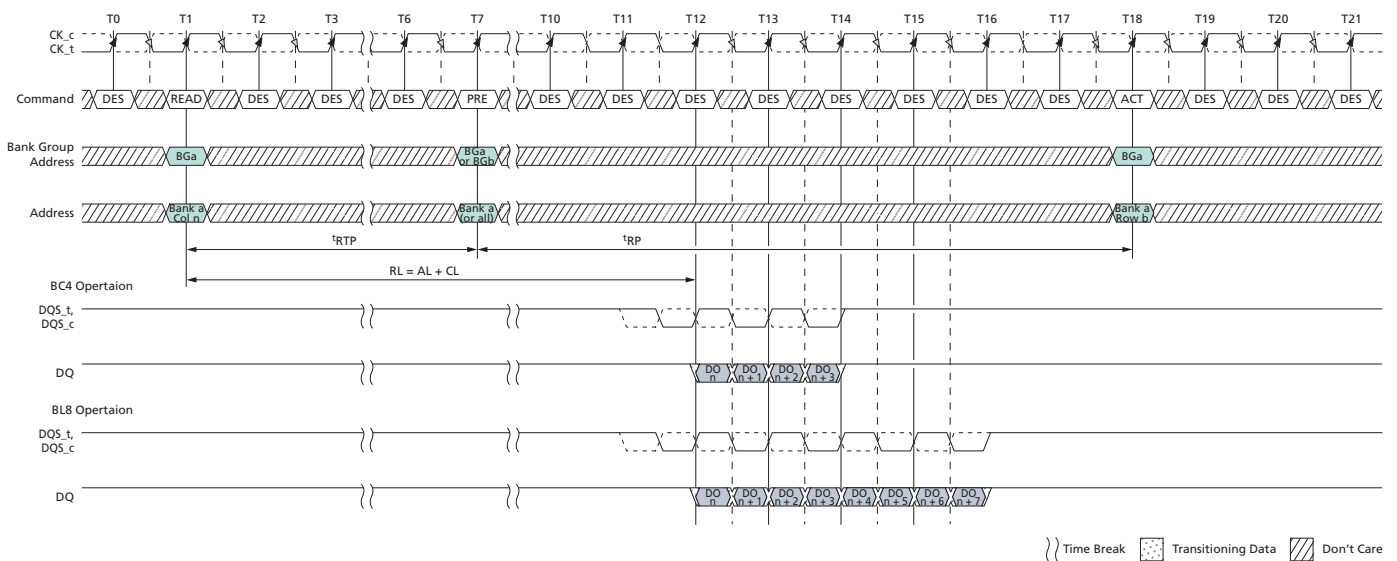
4. BL8 setting activated by MR0[1:0] = 01 and A12 = 1 during READ commands at T0.  
BC4 setting activated by MR0[1:0] = 01 and A12 = 0 during WRITE commands at T8.
5. CA parity = Disable, CS to CA latency = Disable, Read DBI = Disable, Write DBI = Disable,  
Write CRC = Disable.

**READ Operation Followed by PRECHARGE Operation**

The minimum external READ command to PRECHARGE command spacing to the same bank is equal to  $AL + {}^tRTP$  with  ${}^tRTP$  being the internal READ command to PRECHARGE command delay. Note that the minimum ACT to PRE timing,  ${}^tRAS$ , must be satisfied as well. The minimum value for the internal READ command to PRECHARGE command delay is given by  ${}^tRTP (MIN) = MAX(4 \times nCK, 7.5ns)$ . A new bank ACTIVATE command may be issued to the same bank if the following two conditions are satisfied simultaneously:

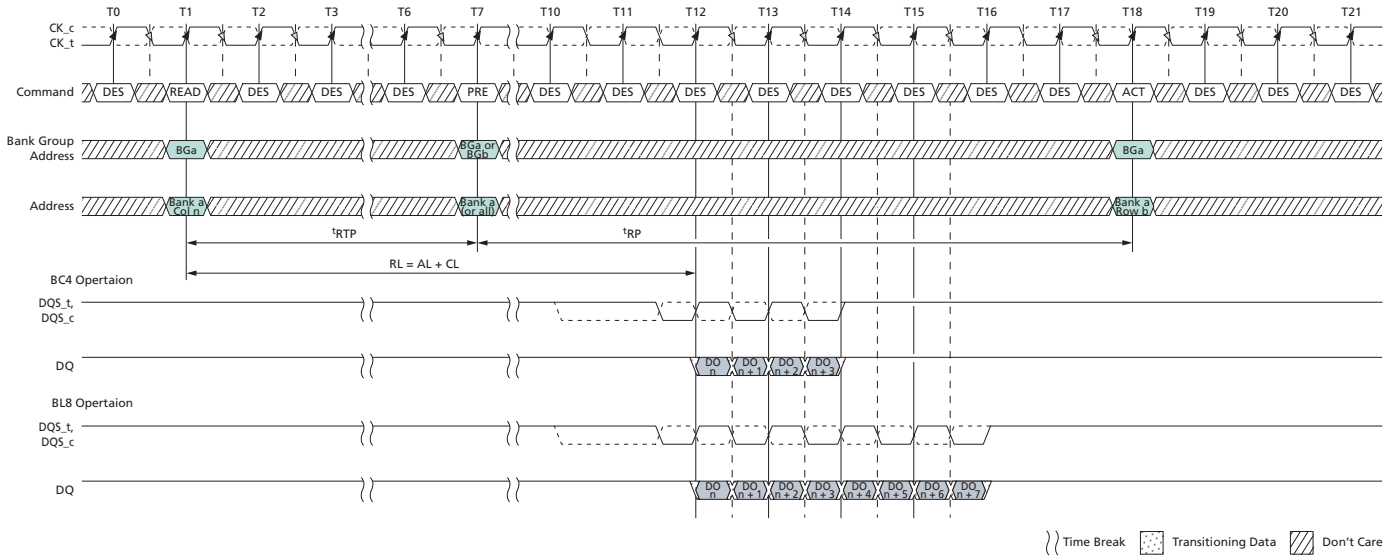
- The minimum RAS precharge time ( ${}^tRP [MIN]$ ) has been satisfied from the clock at which the precharge begins.
- The minimum RAS cycle time ( ${}^tRC [MIN]$ ) from the previous bank activation has been satisfied.

**Figure 144: READ to PRECHARGE with 1<sup>t</sup>CK Preamble**



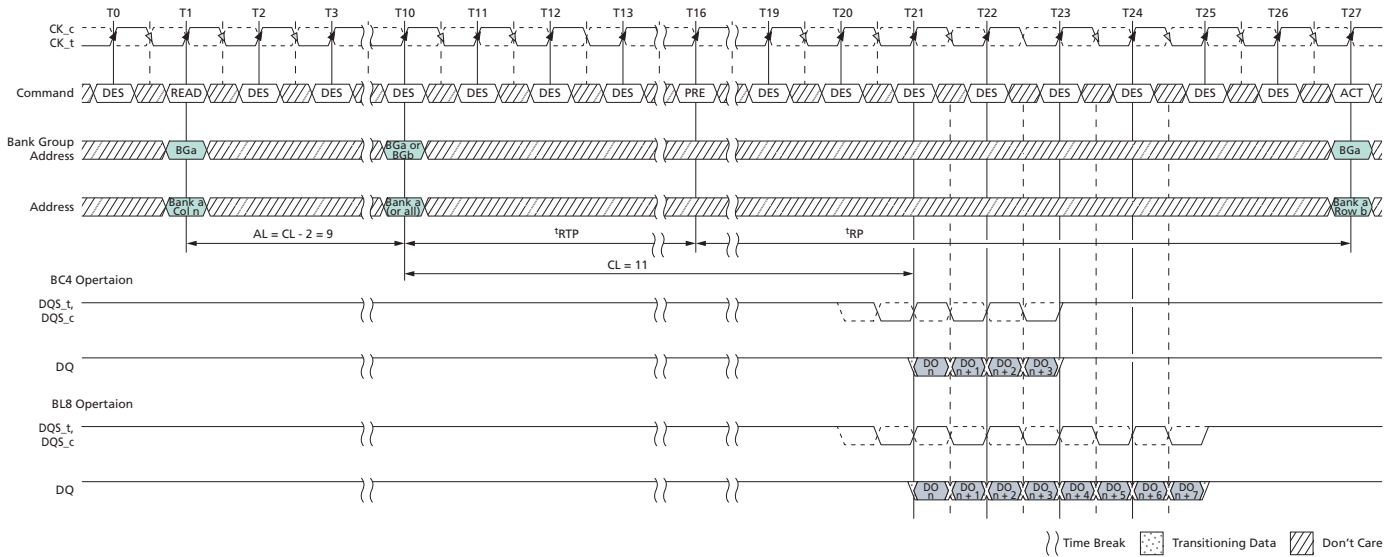
- Notes:
1.  $RL = 11$  ( $CL = 11, AL = 0$ ), Preamble = 1<sup>t</sup>CK,  ${}^tRTP = 6$ ,  ${}^tRP = 11$ .
  2.  $DO_n$  = data-out from column  $n$ .
  3. DES commands are shown for ease of illustration; other commands may be valid at these times.
  4. The example assumes that  ${}^tRAS (MIN)$  is satisfied at the PRECHARGE command time (T7) and that  ${}^tRC (MIN)$  is satisfied at the next ACTIVATE command time (T18).
  5. CA parity = Disable, CS to CA latency = Disable, Read DBI = Disable.

Figure 145: READ to PRECHARGE with 2<sup>t</sup>CK Preamble



- Notes:
1.  $RL = 11$  ( $CL = 11, AL = 0$ ), Preamble =  $2^tCK$ ,  ${}^tRTP = 6$ ,  ${}^tRP = 11$ .
  2.  $DO_n$  = data-out from column  $n$ .
  3. DES commands are shown for ease of illustration; other commands may be valid at these times.
  4. The example assumes that  ${}^tRAS$  (MIN) is satisfied at the PRECHARGE command time (T7) and that  ${}^tRC$  (MIN) is satisfied at the next ACTIVATE command time (T18).
  5. CA parity = Disable, CS to CA latency = Disable, Read DBI = Disable.

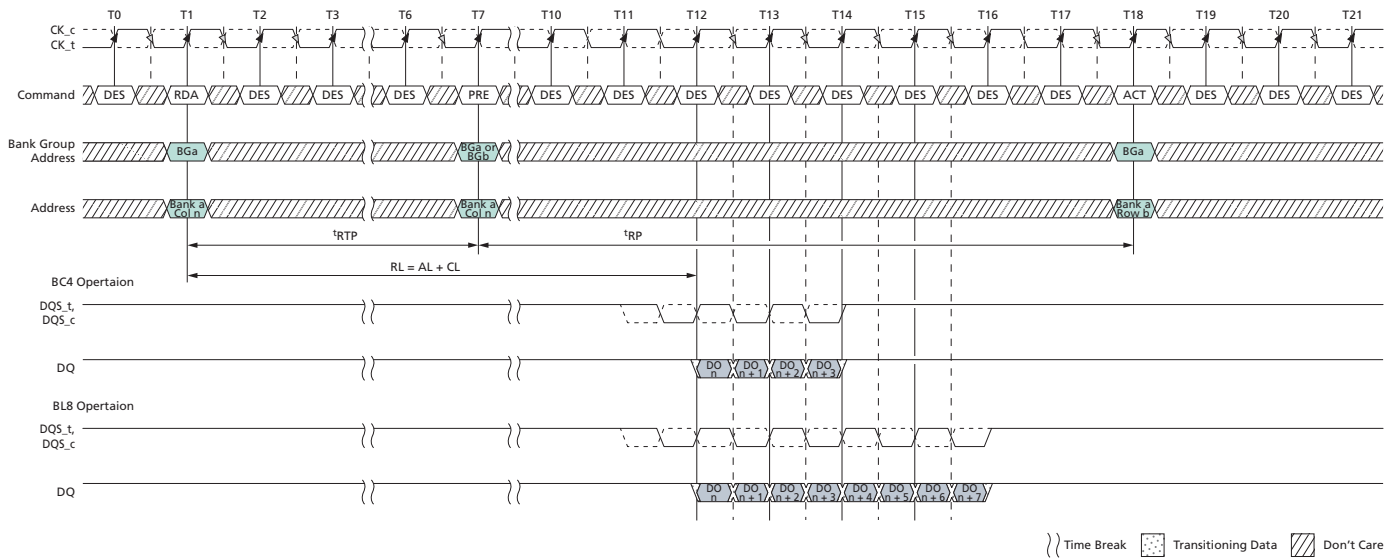
Figure 146: READ to PRECHARGE with Additive Latency and 1<sup>t</sup>CK Preamble



- Notes:
1.  $RL = 20$  ( $CL = 11, AL = CL - 2$ ), Preamble =  $1^tCK$ ,  ${}^tRTP = 6$ ,  ${}^tRP = 11$ .
  2.  $DO_n$  = data-out from column  $n$ .

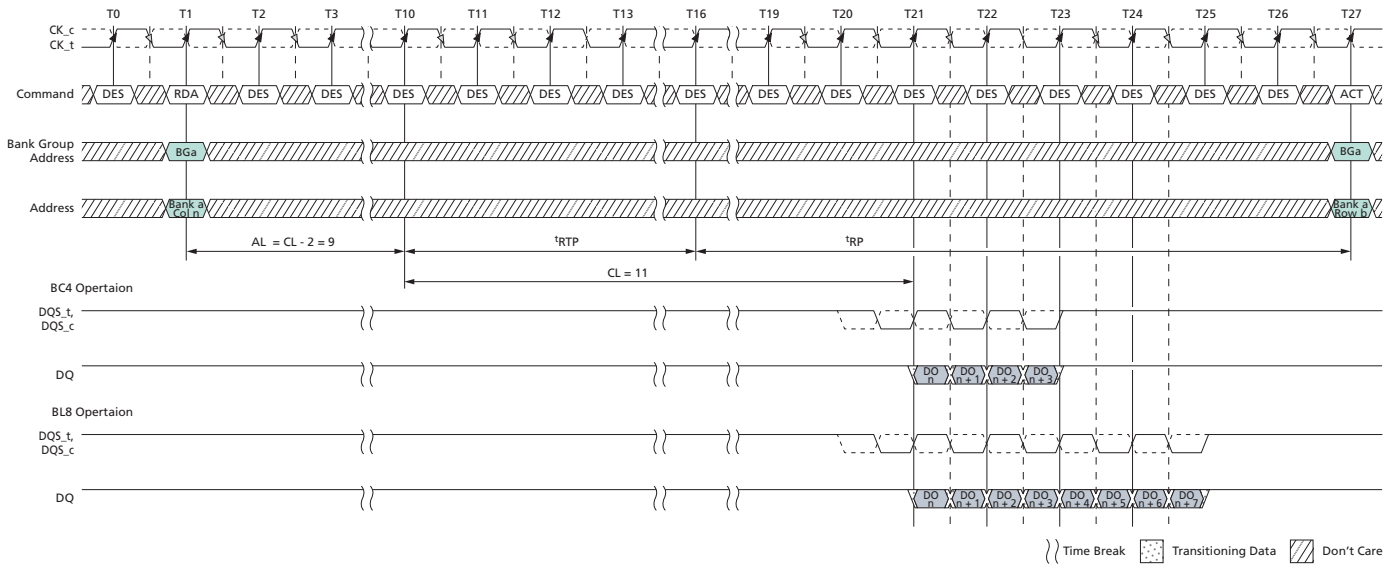
3. DES commands are shown for ease of illustration; other commands may be valid at these times.
4. The example assumes that  $t_{RAS}$  (MIN) is satisfied at the PRECHARGE command time (T16) and that  $t_{RC}$  (MIN) is satisfied at the next ACTIVATE command time (T27).
5. CA parity = Disable, CS to CA latency = Disable, Read DBI = Disable.

**Figure 147: READ with Auto Precharge and 1<sup>t</sup>CK Preamble**



- Notes:
1.  $RL = 11$  ( $CL = 11$ ,  $AL = 0$ ), Preamble =  $1t_{CK}$ ,  $t_{RTP} = 6$ ,  $t_{RP} = 11$ .
  2.  $DO_n$  = data-out from column  $n$ .
  3. DES commands are shown for ease of illustration; other commands may be valid at these times.
  4.  $t_{RTP} = 6$  setting activated by  $MRO[A11:9 = 001]$ .
  5. The example assumes that  $t_{RC}$  (MIN) is satisfied at the next ACTIVATE command time (T18).
  6. CA parity = Disable, CS to CA latency = Disable, Read DBI = Disable.

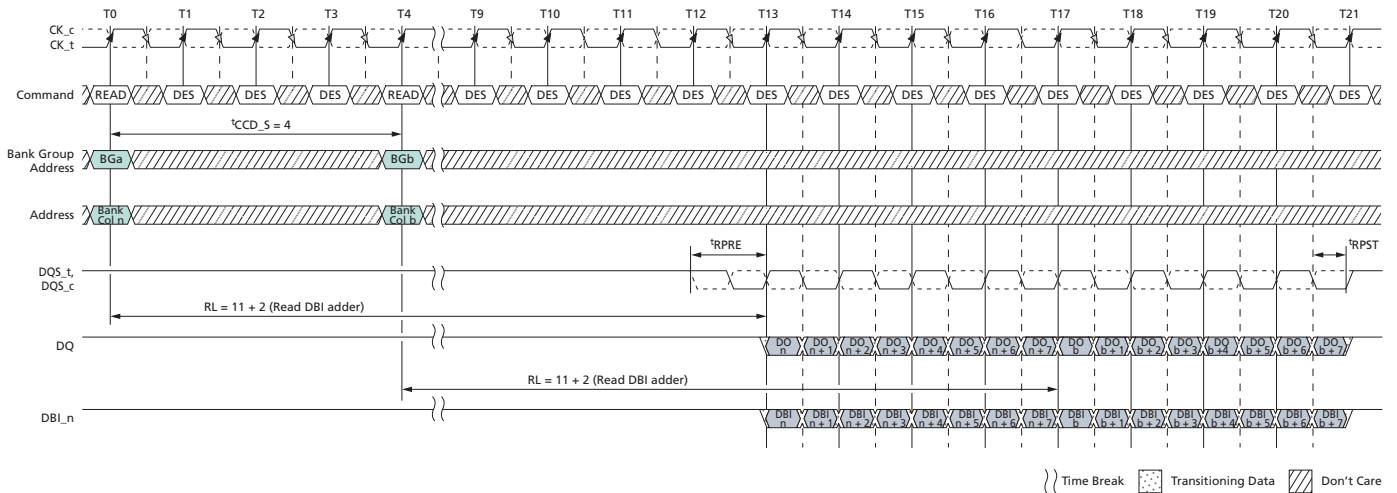
Figure 148: READ with Auto Precharge, Additive Latency, and 1<sup>t</sup>CK Preamble



- Notes:
1. RL = 20 (CL = 11, AL = CL - 2), Preamble = 1<sup>t</sup>CK, <sup>t</sup>RTP = 6, <sup>t</sup>RP = 11.
  2. DO *n* = data-out from column *n*.
  3. DES commands are shown for ease of illustration; other commands may be valid at these times.
  4. <sup>t</sup>RTP = 6 setting activated by MR0[11:9] = 001.
  5. The example assumes that <sup>t</sup>RC (MIN) is satisfied at the next ACTIVATE command time (T27).
  6. CA parity = Disable, CS to CA latency = Disable, Read DBI = Disable.

### READ Operation with Read Data Bus Inversion (DBI)

Figure 149: Consecutive READ (BL8) with 1<sup>t</sup>CK Preamble and DBI in Different Bank Group

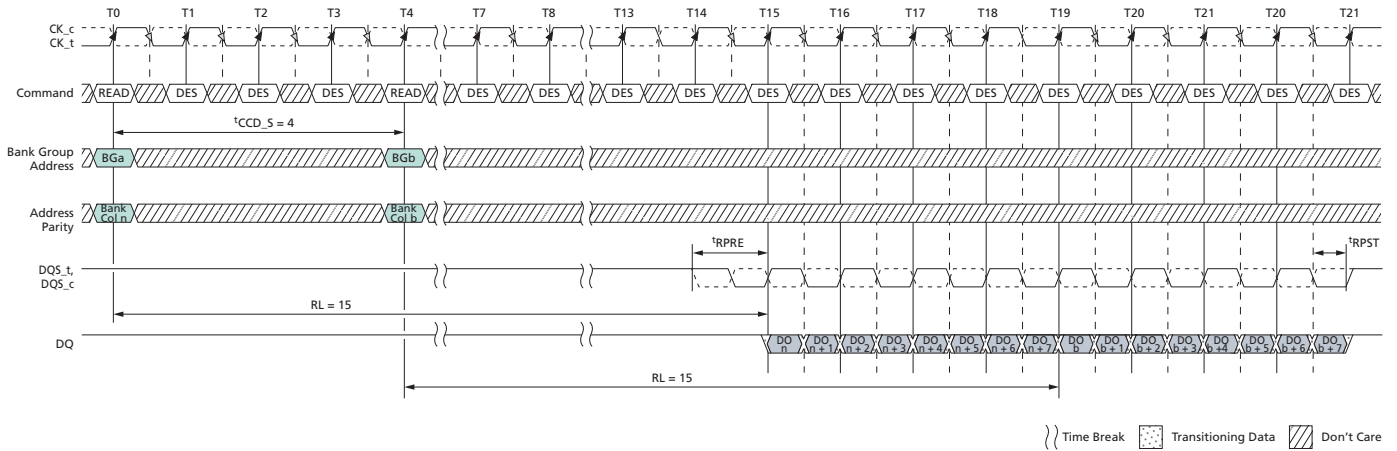


- Notes:
1. BL = 8, AL = 0, CL = 11, Preamble = 1<sup>t</sup>CK, RL = 11 + 2 (Read DBI adder).

- DO  $n$  (or  $b$ ) = data-out from column  $n$  (or  $b$ ); DBI  $n$  (or  $b$ ) = data bus inversion from column  $n$  (or  $b$ ).
- DES commands are shown for ease of illustration; other commands may be valid at these times.
- BL8 setting activated by either MR0[1:0] = 00 or MR0[1:0] = 01 and A12 = 1 during READ commands at T0 and T4.
- CA parity = Disable, CS to CA latency = Disable, Read DBI = Enable.

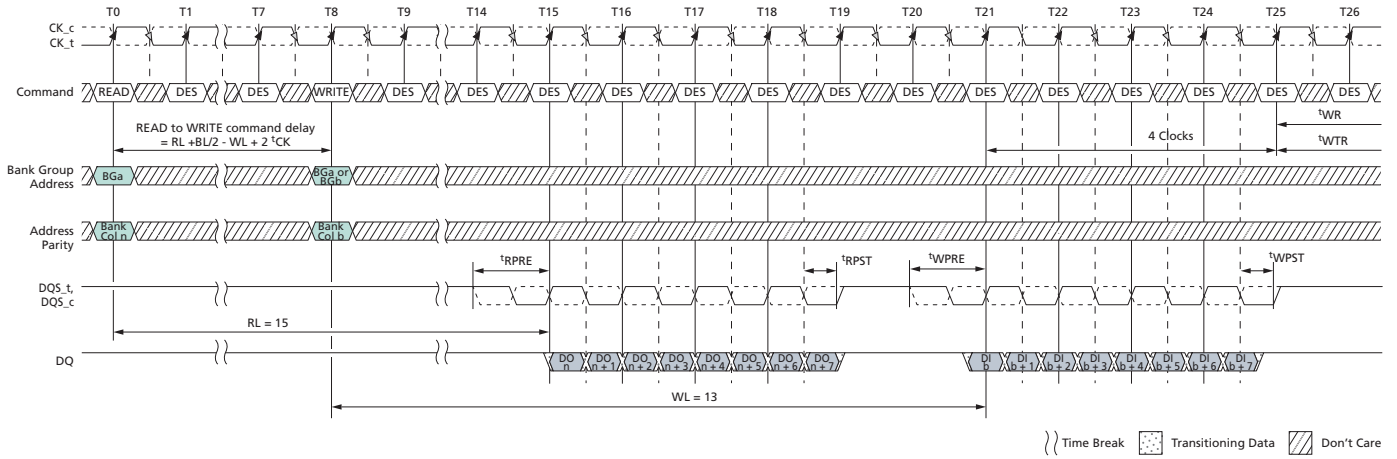
## READ Operation with Command/Address Parity (CA Parity)

**Figure 150: Consecutive READ (BL8) with 1<sup>t</sup>CK Preamble and CA Parity in Different Bank Group**



- Notes:
- BL = 8, AL = 0, CL = 11, PL = 4, (RL = CL + AL + PL = 15), Preamble = 1<sup>t</sup>CK.
  - DO  $n$  (or  $b$ ) = data-out from column  $n$  (or  $b$ ).
  - DES commands are shown for ease of illustration; other commands may be valid at these times.
  - BL8 setting activated by either MR0[A1:A0 = 00] or MR0[A1:A0 = 01] and A12 = 1 during READ commands at T0 and T4.
  - CA parity = Enable, CS to CA latency = Disable, Read DBI = Disable.

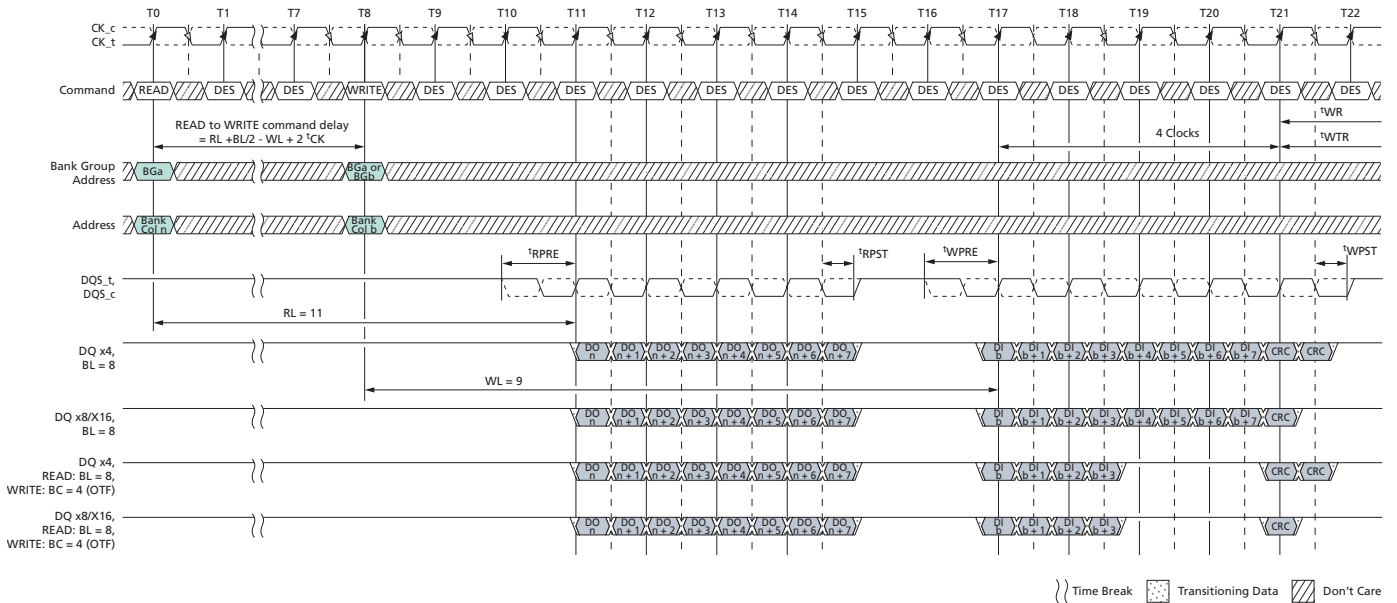
**Figure 151: READ (BL8) to WRITE (BL8) with 1<sup>t</sup>CK Preamble and CA Parity in Same or Different Bank Group**



- Notes:
1. BL = 8, AL = 0, CL = 11, PL = 4, (RL = CL + AL + PL = 15), READ preamble = 1<sup>t</sup>CK, CWL = 9, AL = 0, PL = 4, (WL = CL + AL + PL = 13), WRITE preamble = 1<sup>t</sup>CK.
  2. DO *n* = data-out from column *n*, DI *b* = data-in from column *b*.
  3. DES commands are shown for ease of illustration; other commands may be valid at these times.
  4. BL8 setting activated by either MR0[1:0] = 00 or MR0[1:0] = 01 and A12 = 1 during READ commands at T0 and WRITE command at T8.
  5. CA parity = Enable, CS to CA latency = Disable, Read DBI = Disable, Write DBI = Disable, Write CRC = Disable.

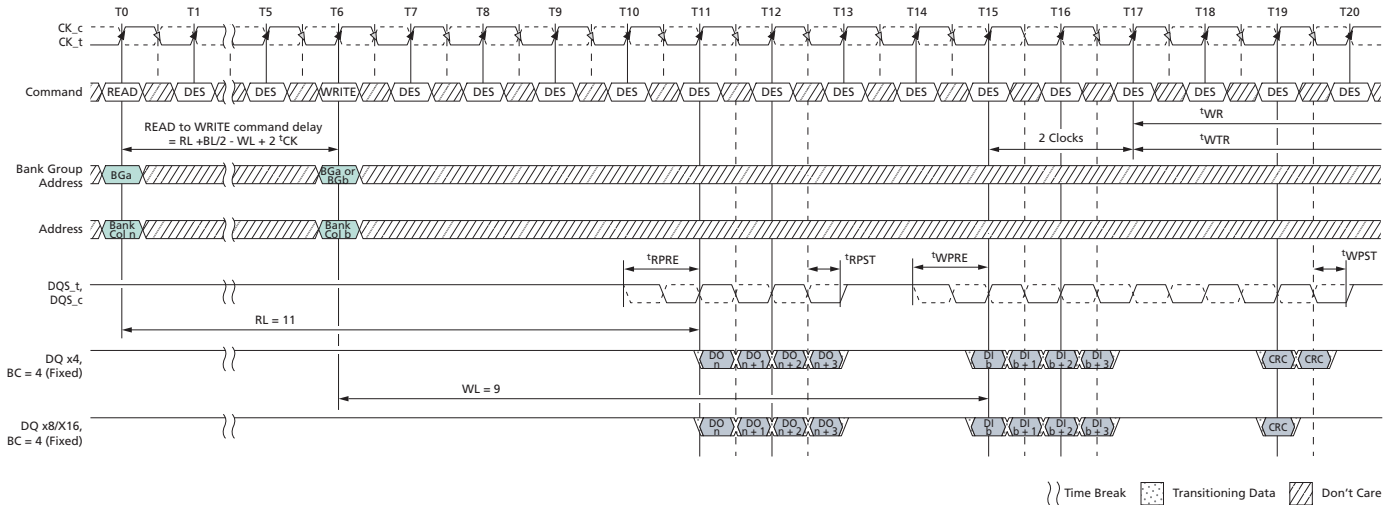
### READ Followed by WRITE with CRC Enabled

**Figure 152: READ (BL8) to WRITE (BL8 or BC4: OTF) with 1<sup>t</sup>CK Preamble and Write CRC in Same or Different Bank Group**



- Notes:
1. BL = 8 (or BC = 4: OTF for Write), RL = 11 (CL = 11, AL = 0), READ preamble = 1<sup>t</sup>CK, WL = 9 (CWL = 9, AL = 0), WRITE preamble = 1<sup>t</sup>CK.
  2. DO *n* = data-out from column *n*, DI *b* = data-in from column *b*.
  3. DES commands are shown for ease of illustration; other commands may be valid at these times.
  4. BL8 setting activated by either MR0[1:0] = 00 or MR0[1:0] = 01 and A12 = 1 during READ commands at T0 and WRITE commands at T8.
  5. BC4 setting activated by MR0[1:0] = 01 and A12 = 0 during WRITE commands at T8.
  6. CA parity = Disable, CS to CA latency = Disable, Read DBI = Disable, Write DBI = Disable, Write CRC = Enable.

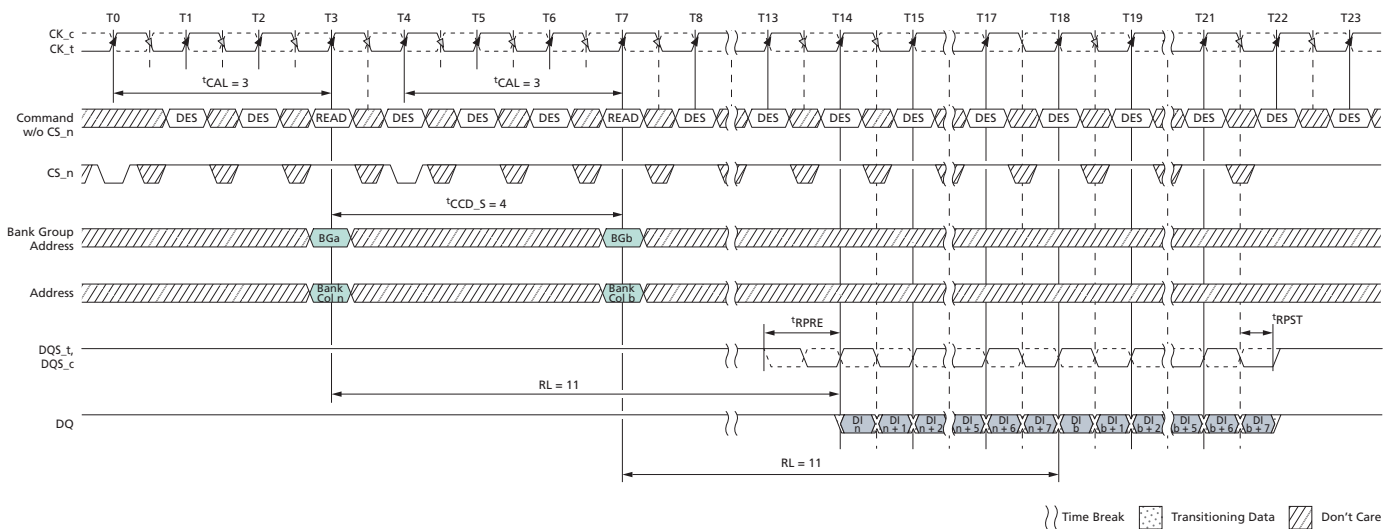
**Figure 153: READ (BC4: Fixed) to WRITE (BC4: Fixed) with 1<sup>t</sup>CK Preamble and Write CRC in Same or Different Bank Group**



- Notes:
1. BC = 4 (Fixed), RL = 11 (CL = 11, AL = 0), READ preamble = 1<sup>t</sup>CK, WL = 9 (CWL = 9, AL = 0), WRITE preamble = 1<sup>t</sup>CK.
  2. DO *n* = data-out from column *n*, DI *b* = data-in from column *b*.
  3. DES commands are shown for ease of illustration; other commands may be valid at these times.
  4. BC4 setting activated by MR0[1:0] = 10.
  5. CA parity = Disable, CS to CA latency = Disable, Read DBI = Disable, Write DBI = Disable, Write CRC = Enable.

### READ Operation with Command/Address Latency (CAL) Enabled

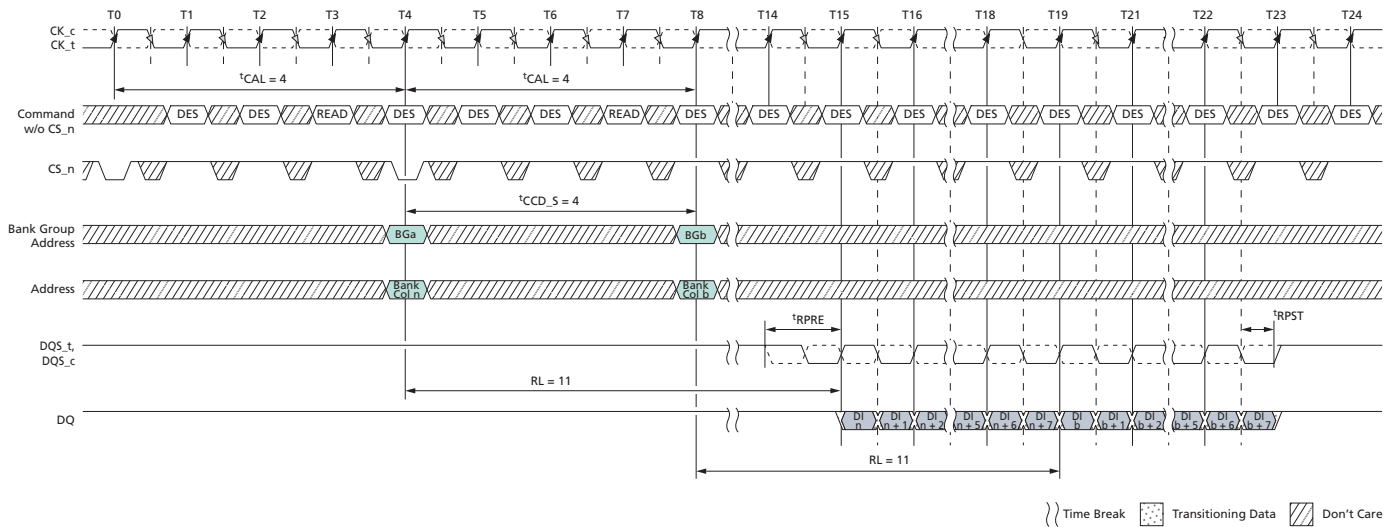
**Figure 154: Consecutive READ (BL8) with CAL (3<sup>t</sup>CK) and 1<sup>t</sup>CK Preamble in Different Bank Group**



- Notes:
1. BL = 8, RL = 11 (CL = 11, AL = 0), READ preamble = 1<sup>t</sup>CK.

2. DI  $n$  (or  $b$ ) = data-in from column  $n$  (or  $b$ ).
3. DES commands are shown for ease of illustration; other commands may be valid at these times.
4. BL8 setting activated by either MR0[1:0] = 00 or MR0[1:0] = 01 and A12 = 1 during READ commands at T3 and T7.
5. CA parity = Enable, CS to CA latency = Enable, Read DBI = Disable, Write DBI = Disable, Write CRC = Disable.
6. Enabling CAL mode does not impact ODT control timings. The same timing relationship relative to the command/address bus as when CAL is disabled should be maintained.

**Figure 155: Consecutive READ (BL8) with CAL (4<sup>t</sup>CK) and 1<sup>t</sup>CK Preamble in Different Bank Group**



- Notes:
1. BL = 8, RL = 11 (CL = 11, AL = 0), READ preamble = 1<sup>t</sup>CK.
  2. DI  $n$  (or  $b$ ) = data-in from column  $n$  (or  $b$ ).
  3. DES commands are shown for ease of illustration; other commands may be valid at these times.
  4. BL8 setting activated by either MR0[1:0] = 00 or MR0[1:0] = 01 and A12 = 1 during READ commands at T3 and T7.
  5. CA parity = Enable, CS to CA latency = Enable, Read DBI = Disable, Write DBI = Disable, Write CRC = Disable.
  6. Enabling CAL mode does not impact ODT control timings. The same timing relationship relative to the command/address bus as when CAL is disabled should be maintained.

## WRITE Operation

### Write Timing Definitions

The write timings shown in the following figures are applicable in normal operation mode, that is, when the DLL is enabled and locked.

### Write Timing – Clock-to-Data Strobe Relationship

The clock-to-data strobe relationship is shown below and is applicable in normal operation mode, that is, when the DLL is enabled and locked.

Rising data strobe edge parameters:

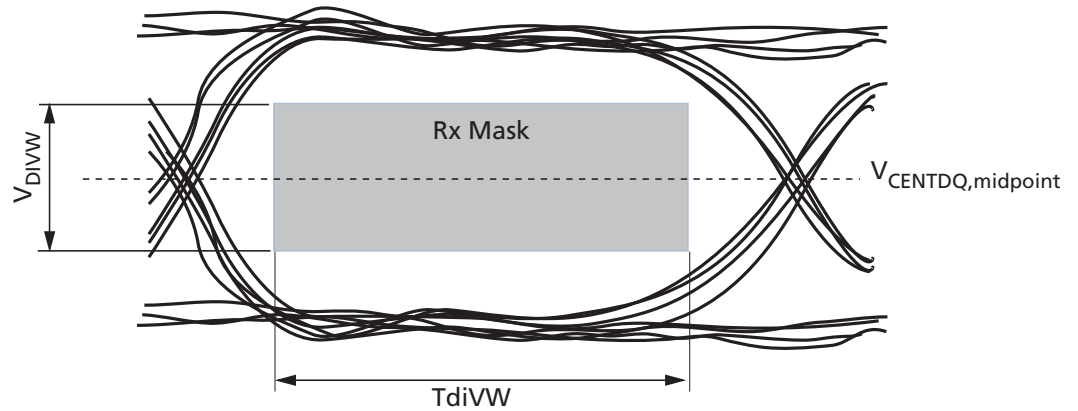
- $t^{\text{DQSS}}$  (MIN) to  $t^{\text{DQSS}}$  (MAX) describes the allowed range for a rising data strobe edge relative to CK.
- $t^{\text{DQSS}}$  is the actual position of a rising strobe edge relative to CK.
- $t^{\text{DQSH}}$  describes the data strobe high pulse width.
- $t^{\text{WPST}}$  strobe going to HIGH, nondrive level (shown in the postamble section of the graphic below).

Falling data strobe edge parameters:

- $t^{\text{DQSL}}$  describes the data strobe low pulse width.
- $t^{\text{WPRE}}$  strobe going to LOW, initial drive level (shown in the preamble section of the graphic below).

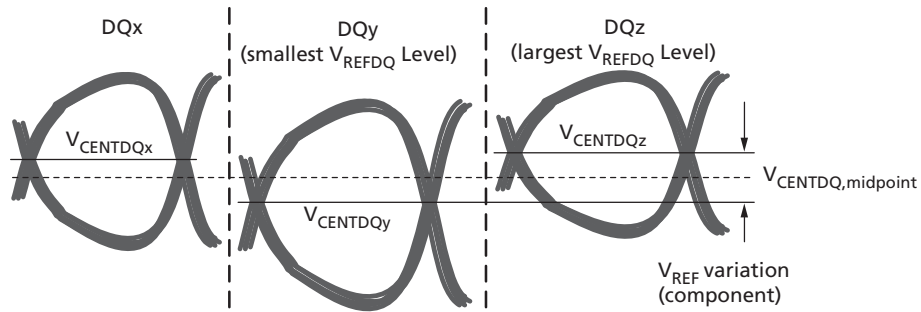


Figure 157: Rx Compliance Mask



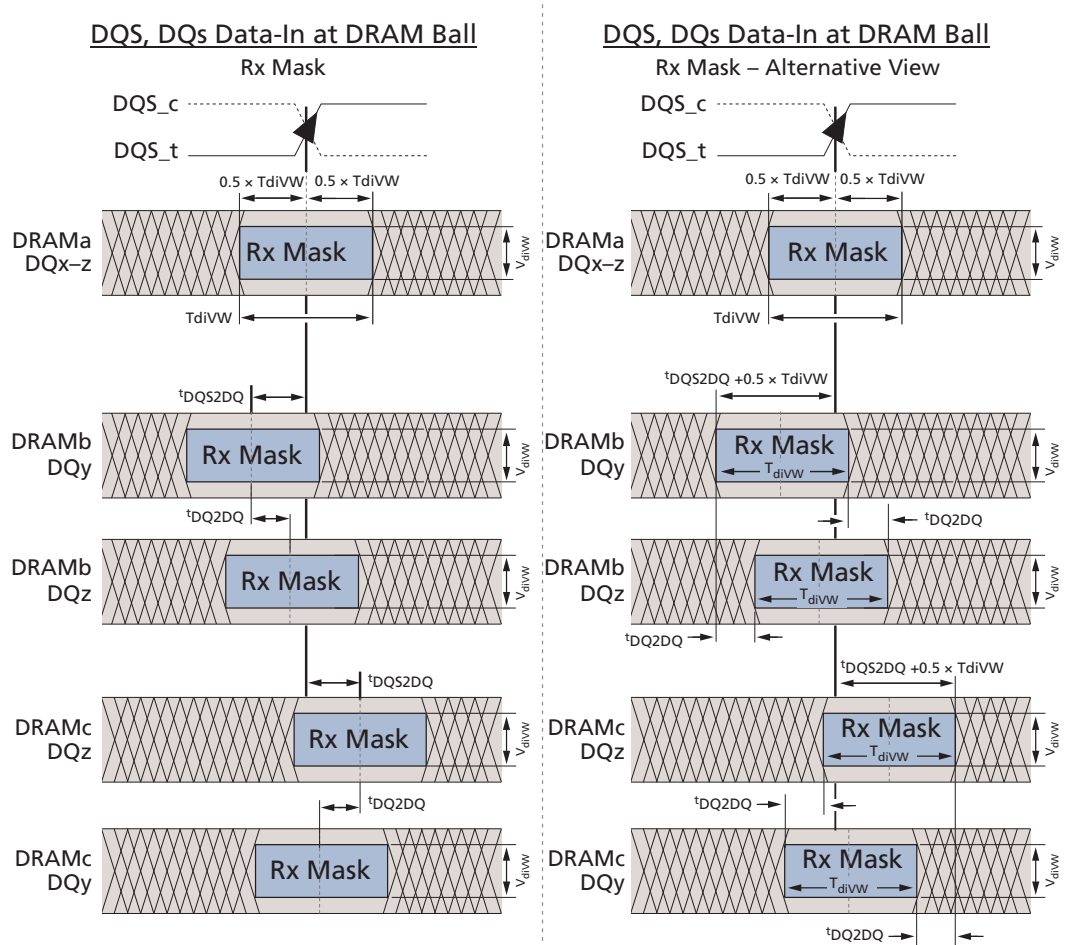
$V_{CENTDQ,midpoint}$  is defined as the midpoint between the largest  $V_{REFDQ}$  voltage level and the smallest  $V_{REFDQ}$  voltage level across all DQ pins for a given DRAM. Each DQ pin's  $V_{REFDQ}$  is defined by the center (widest opening) of the cumulative data input eye as depicted in the following figure. This means a DRAM's level variation is accounted for within the DRAM Rx mask. The DRAM  $V_{REFDQ}$  level will be set by the system to account for  $R_{ON}$  and ODT settings.

Figure 158:  $V_{CENT\_DQ}$   $V_{REFDQ}$  Voltage Variation



The following figure shows the Rx mask requirements both from a midpoint-to-midpoint reference (left side) and from an edge-to-edge reference. The intent is not to add any new requirement or specification between the two but rather how to convert the relationship between the two methodologies. The minimum data-eye shown in the composite view is not actually obtainable due to the minimum pulse width requirement.

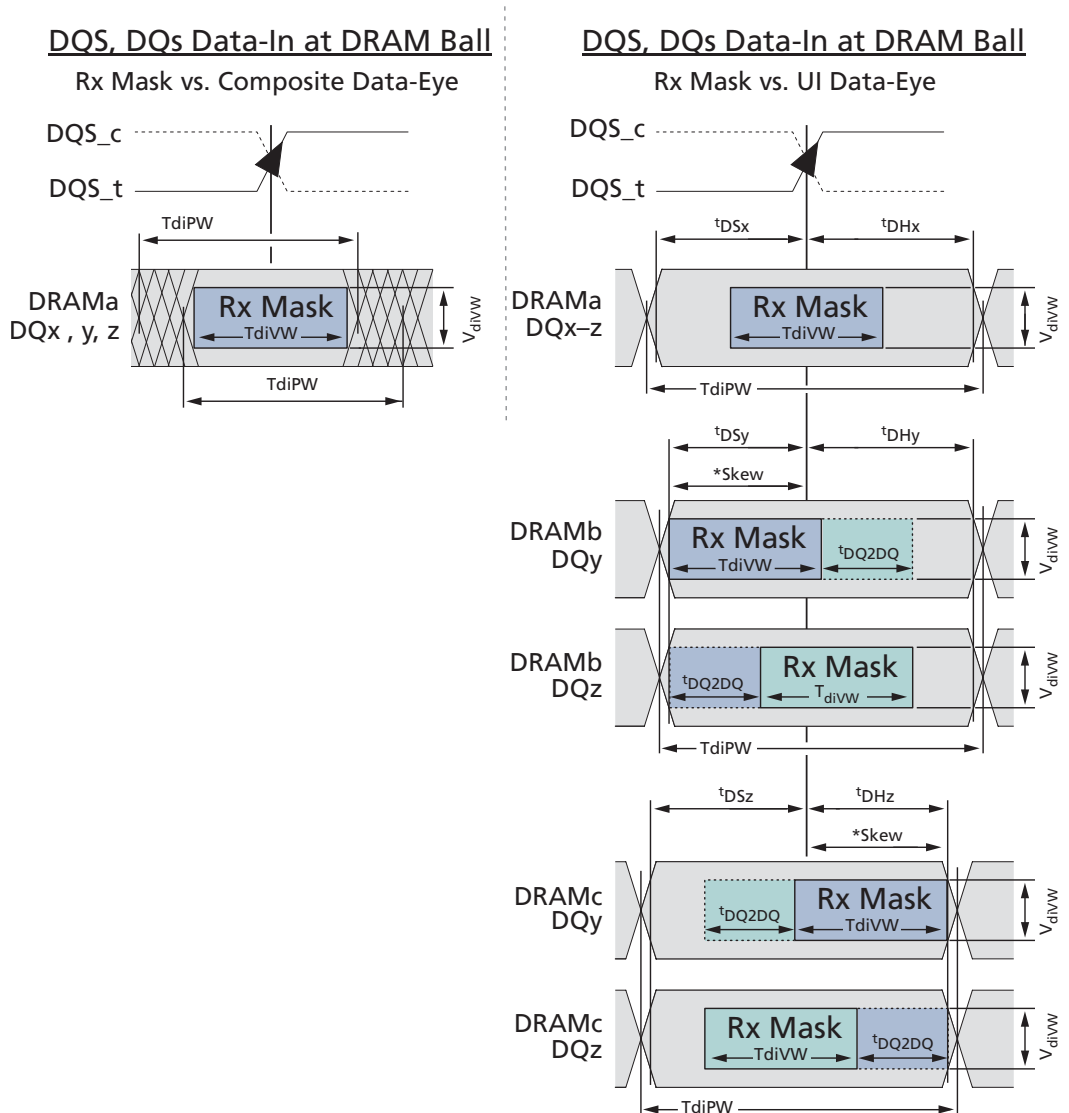
Figure 159: Rx Mask DQ-to-DQS Timings



- Notes:
1. DQx represents an optimally centered mask.  
DQy represents earliest valid mask.  
DQz represents latest valid mask.
  2. DRAMa represents a DRAM without any DQS/DQ skews.  
DRAMb represents a DRAM with early skews (negative  $t_{DQS2DQ}$ ).  
DRAMc represents a DRAM with delayed skews (positive  $t_{DQS2DQ}$ ).
  3. This figure shows the skew allowed between DRAM-to-DRAM and between DQ-to-DQ for a DRAM. Signals assume data is center-aligned at DRAM latch.  
 $T_{diPW}$  is not shown; composite data-eyes shown would violate  $T_{diPW}$ .  
 $V_{CENTDQ,midpoint}$  is not shown but is assumed to be midpoint of  $V_{diVW}$ .

The previous figure shows the basic Rx mask requirements. Converting the Rx mask requirements to a classical DQ-to-DQS relationship is shown in the following figure. It should become apparent that DRAM write training is required to take full advantage of the Rx mask.

**Figure 160: Rx Mask DQ-to-DQS DRAM-Based Timings**

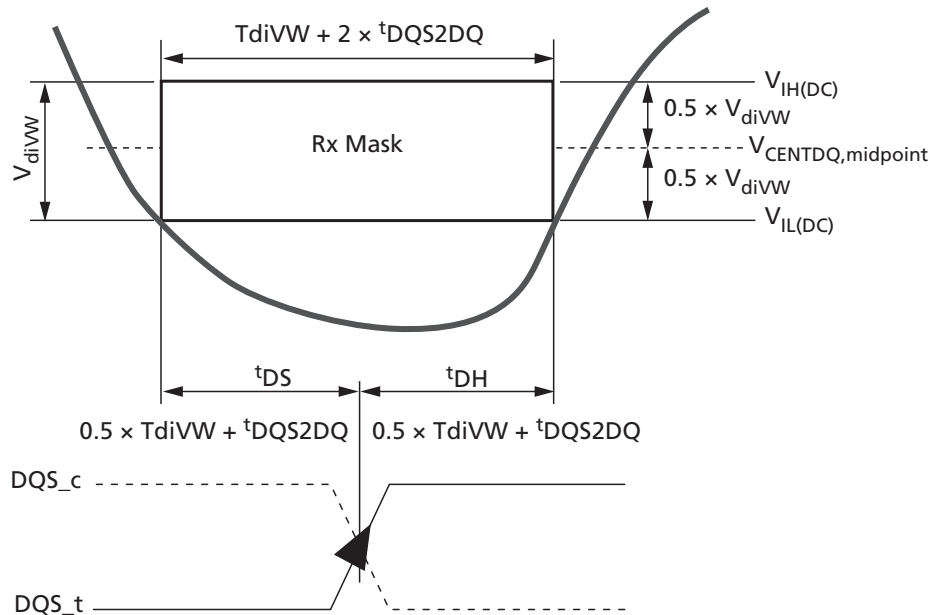


- Notes:
1. DQx represents an optimally centered mask.  
DQy represents earliest valid mask.  
DQz represents latest valid mask.
  2.  $*Skew = t_{DQS2DQ} + 0.5 \times T_{diVW}$   
DRAMa represents a DRAM without any DQS/DQ skews.  
DRAMb represents a DRAM with the earliest skews (negative  $t_{DQS2DQ}$ ,  $t_{DQSy} > *Skew$ ).  
DRAMc represents a DRAM with the latest skews (positive  $t_{DQS2DQ}$ ,  $t_{DQHz} > *Skew$ ).
  3.  $t_{DS}/t_{DH}$  are traditional data-eye setup/hold edges at DC levels.  
 $t_{DS}$  and  $t_{DH}$  are not specified;  $t_{DH}$  and  $t_{DS}$  may be any value provided the pulse width and Rx mask limits are not violated.  
 $t_{DH} (MIN) > T_{diVW} + t_{DS} (MIN) + t_{DQ2DQ}$ .

The DDR4 SDRAM's input receivers are expected to capture the input data with an Rx mask of  $T_{diVW}$  provided the minimum pulse width is satisfied. The DRAM controller will have to train the data input buffer to utilize the Rx mask specifications to this maxi-

imum benefit. If the DRAM controller does not train the data input buffers, then the worst case limits have to be used for the Rx mask ( $T_{diVW} + 2 \times t_{DQS2DQ}$ ), which will generally be the classical minimum ( $t_{DS}$  and  $t_{DH}$ ) and is required as well.

**Figure 161: Example of Data Input Requirements Without Training**



## WRITE Burst Operation

The following write timing diagrams are intended to help understand each write parameter's meaning and are only examples. Each parameter will be defined in detail separately. In these write timing diagrams, CK and DQS are shown aligned, and DQS and DQ are shown center-aligned for the purpose of illustration.

DDR4 WRITE command supports bursts of BL8 (fixed), BC4 (fixed), and BL8/BC4 on-the-fly (OTF); OTF uses address A12 to control OTF when OTF is enabled:

- A12 = 0, BC4 (BC4 = burst chop)
- A12 = 1, BL8

WRITE commands can issue precharge automatically with a WRITE with auto precharge (WRA) command, which is enabled by A10 HIGH.

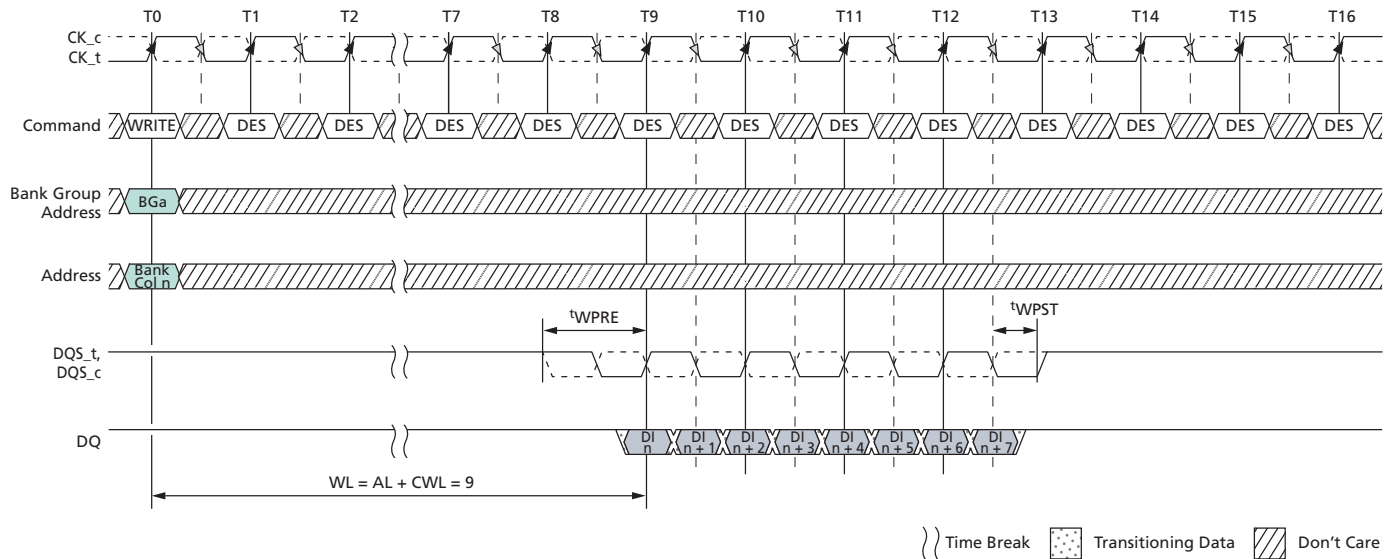
- WRITE command with A10 = 0 (WR) performs standard write, bank remains active after WRITE burst
- WRITE command with A10 = 1 (WRA) performs write with auto precharge, bank goes into precharge after WRITE burst

The DATA MASK (DM) function is supported for the x8 and x16 configurations only (the DM function is not supported on x4 devices). The DM function shares a common pin with the DBI\_n and TDQS functions. The DM function only applies to WRITE operations and cannot be enabled at the same time the DBI function is enabled.

- If DM\_n is sampled LOW on a given byte lane, the DRAM masks the write data received on the DQ inputs.

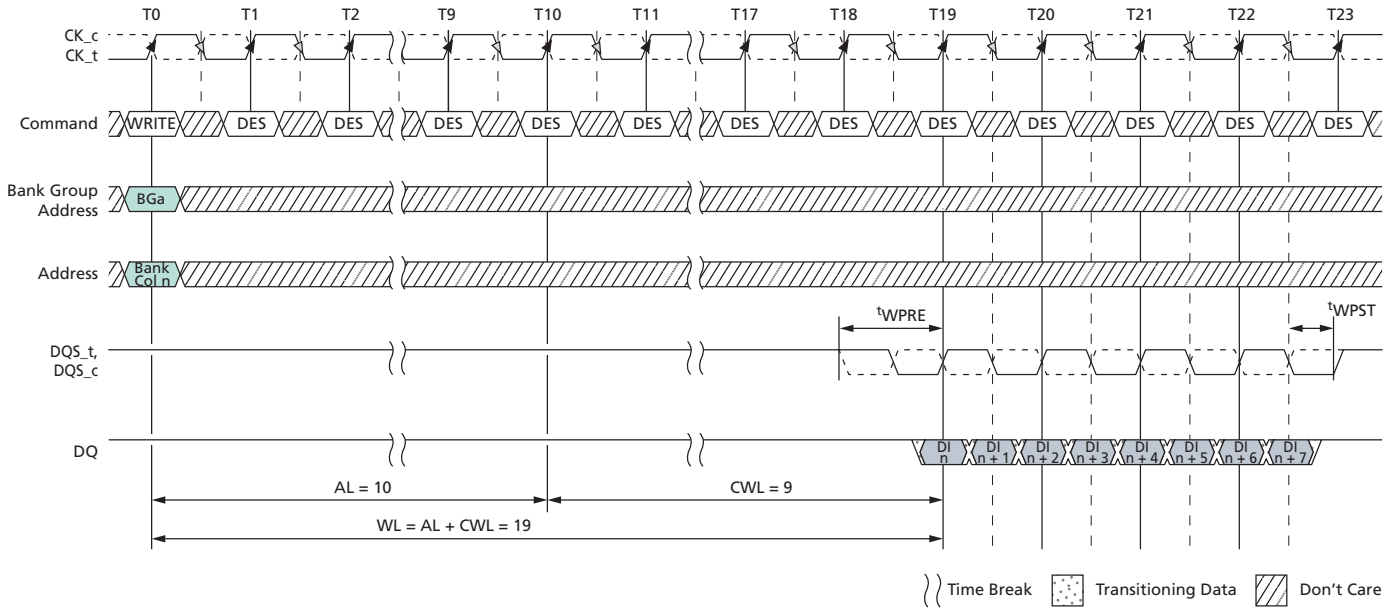
- If DM\_n is sampled HIGH on a given byte lane, the DRAM does not mask the data and writes this data into the DRAM core.
- If CRC write is enabled, then DM enabled (via MRS) will be selected between write CRC nonpersistent mode (DM disabled) and write CRC persistent mode (DM enabled).

**Figure 162: WRITE Burst Operation, WL = 9 (AL = 0, CWL = 9, BL8)**



- Notes:
1. BL8, WL = 0, AL = 0, CWL = 9, Preamble = 1<sup>t</sup>CK.
  2. DI n = Data-in from column n.
  3. DES commands are shown for ease of illustration; other commands may be valid at these times.
  4. BL8 setting activated by either MR0[1:0] = 00 or MR0[1:0] = 01 and A12 = 1 during WRITE command at T0.
  5. CA parity = Disable, CS to CA atency = Disable, Read DBI = Disable.

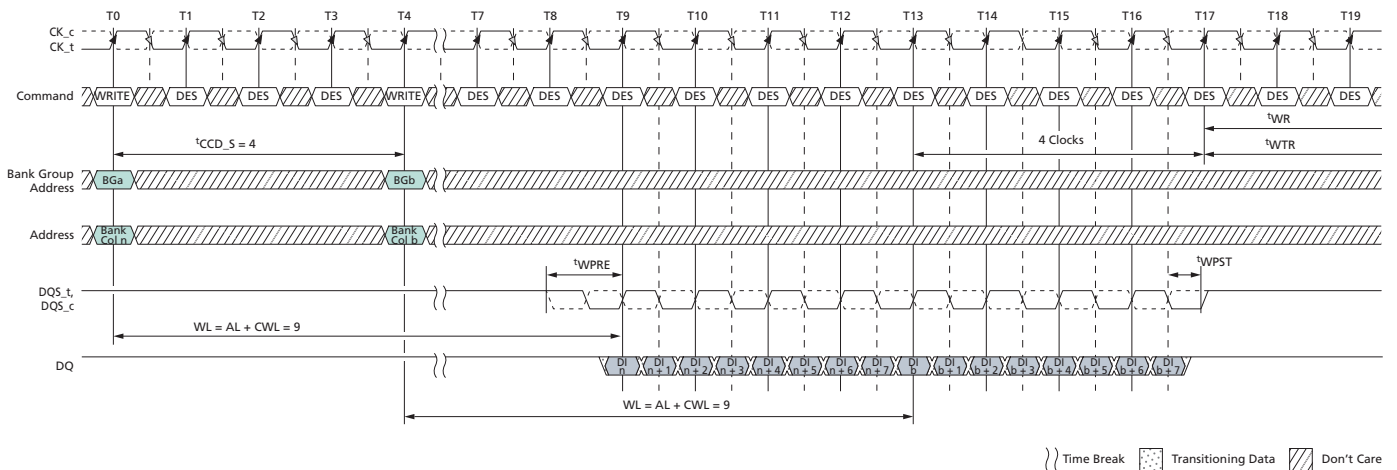
**Figure 163: WRITE Burst Operation, WL = 19 (AL = 10, CWL = 9, BL8)**



- Notes:
1. BL8, WL = 19, AL = 10 (CL - 1), CWL = 9, Preamble = 1<sup>t</sup>CK.
  2. DI *n* = data-in from column *n*.
  3. DES commands are shown for ease of illustration; other commands may be valid at these times.
  4. BL8 setting activated by either MR0[1:0] = 00 or MR0[1:0] = 01 and A12 = 1 during WRITE command at T0.
  5. CA parity = Disable, CS to CA latency = Disable, Read DBI = Disable.

## WRITE Operation Followed by Another WRITE Operation

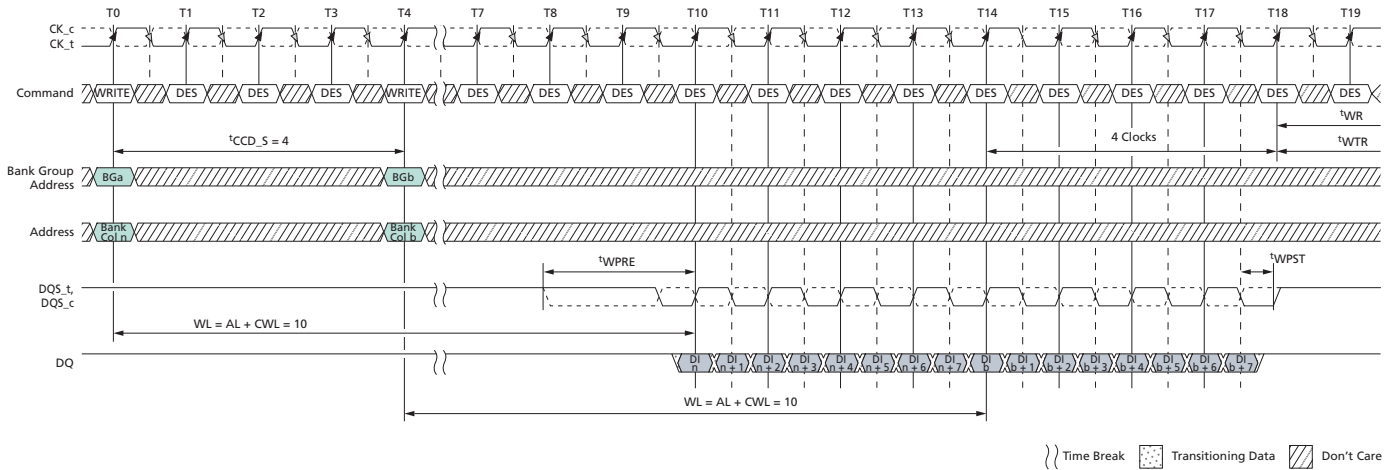
**Figure 164: Consecutive WRITE (BL8) with 1<sup>t</sup>CK Preamble in Different Bank Group**



- Notes:
1. BL8, AL = 0, CWL = 9, Preamble = 1<sup>t</sup>CK.
  2. DI *n* (or *b*) = data-in from column *n* (or column *b*).

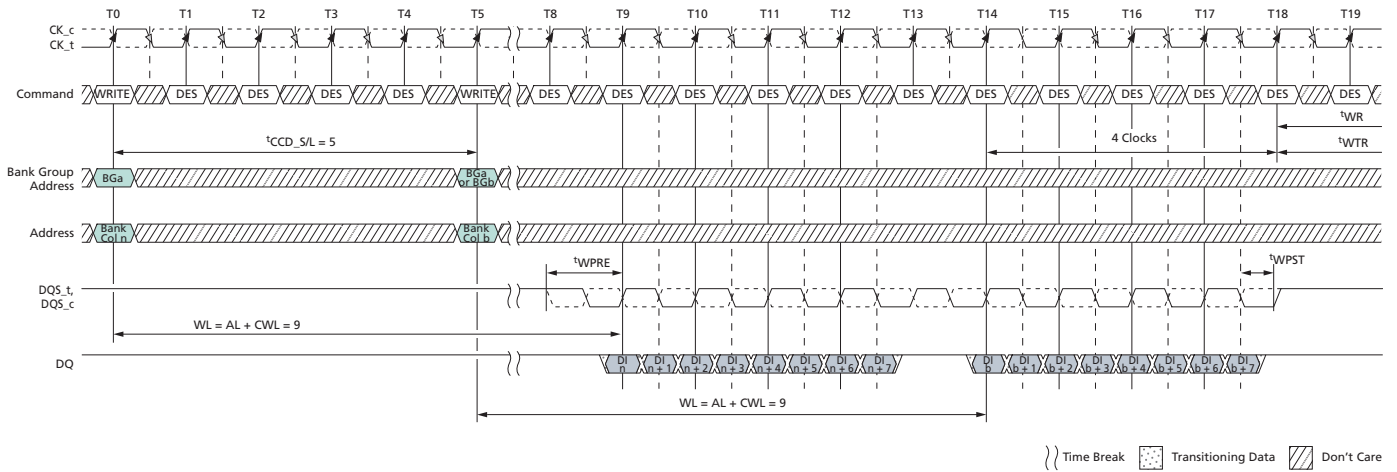
3. DES commands are shown for ease of illustration; other commands may be valid at these times.
4. BL8 setting activated by either MR0[1:0] = 00 or MR0[1:0] = 01 and A12 = 1 during WRITE commands at T0 and T4.
5. CA parity = Disable, CS to CA latency = Disable, Write DBI = Disable, Write CRC = Disable.
6. The write recovery time ( $t^{\text{WR}}$ ) and write timing parameter ( $t^{\text{WTR}}$ ) are referenced from the first rising clock edge after the last write data shown at T17.

**Figure 165: Consecutive WRITE (BL8) with  $2^{\text{tCK}}$  Preamble in Different Bank Group**



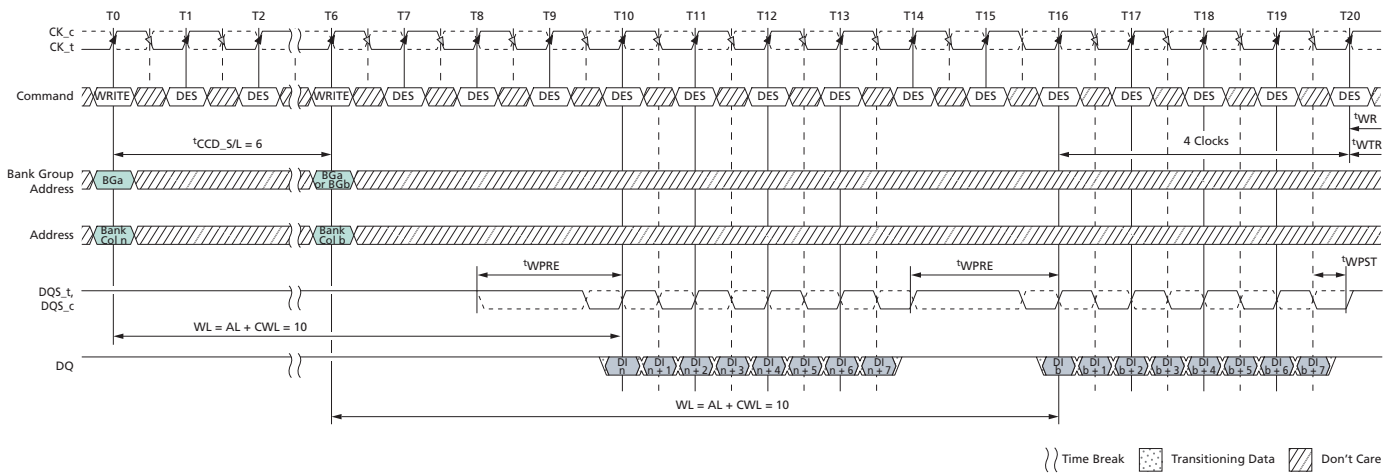
- Notes:
1. BL8, AL = 0, CWL = 9 + 1 = 10 (see Note 7), Preamble =  $2^{\text{tCK}}$ .
  2. DI  $n$  (or  $b$ ) = data-in from column  $n$  (or column  $b$ ).
  3. DES commands are shown for ease of illustration; other commands may be valid at these times.
  4. BL8 setting activated by either MR0[1:0] = 00 or MR0[1:0] = 01 and A12 = 1 during WRITE commands at T0 and T4.
  5. CA parity = Disable, CS to CA latency = Disable, Write DBI = Disable, Write CRC = Disable.
  6. The write recovery time ( $t^{\text{WR}}$ ) and write timing parameter ( $t^{\text{WTR}}$ ) are referenced from the first rising clock edge after the last write data shown at T17.
  7. When operating in  $2^{\text{tCK}}$  WRITE preamble mode, CWL may need to be programmed to a value at least 1 clock greater than the lowest CWL setting supported in the applicable  $^{\text{tCK}}$  range, which means CWL = 9 is not allowed when operating in  $2^{\text{tCK}}$  WRITE preamble mode.

**Figure 166: Nonconsecutive WRITE (BL8) with 1<sup>t</sup>CK Preamble in Same or Different Bank Group**



- Notes:
1. BL8, AL = 0, CWL = 9, Preamble = 1<sup>t</sup>CK, t<sub>CCD\_S/L</sub> = 5<sup>t</sup>CK.
  2. DI *n* (or *b*) = data-in from column *n* (or column *b*).
  3. DES commands are shown for ease of illustration; other commands may be valid at these times.
  4. BL8 setting activated by either MR0[1:0] = 00 or MR0[1:0] = 01 and A12 = 1 during WRITE commands at T0 and T5.
  5. CA parity = Disable, CS to CA latency = Disable, Write DBI = Disable, Write CRC = Disable.
  6. The write recovery time (t<sub>WR</sub>) and write timing parameter (t<sub>WTR</sub>) are referenced from the first rising clock edge after the last write data shown at T18.

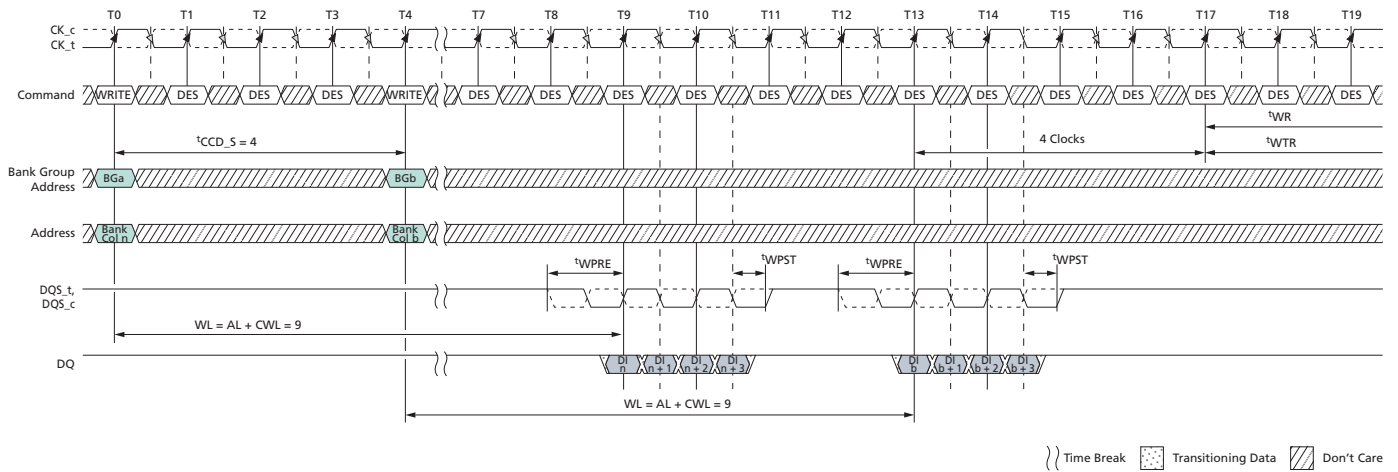
**Figure 167: Nonconsecutive WRITE (BL8) with 2<sup>t</sup>CK Preamble in Same or Different Bank Group**



- Notes:
1. BL8, AL = 0, CWL = 9 + 1 = 10 (see Note 8), Preamble = 2<sup>t</sup>CK, t<sub>CCD\_S/L</sub> = 6<sup>t</sup>CK.
  2. DI *n* (or *b*) = data-in from column *n* (or column *b*).
  3. DES commands are shown for ease of illustration; other commands may be valid at these times.
  4. BL8 setting activated by either MR0[1:0] = 00 or MR0[1:0] = 01 and A12 = 1 during WRITE commands at T0 and T6.

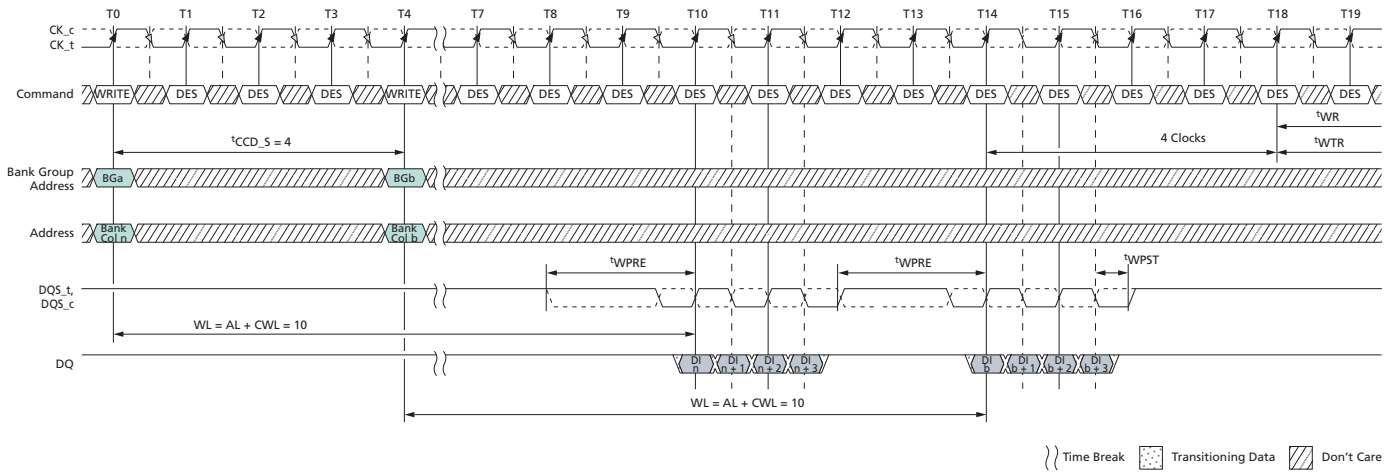
5. CA parity = Disable, CS to CA latency = Disable, Write DBI = Disable, Write CRC = Disable.
6.  $t_{CCD\_S/L} = 5$  isn't allowed in  $2^tCK$  preamble mode.
7. The write recovery time ( $t_{WR}$ ) and write timing parameter ( $t_{WTR}$ ) are referenced from the first rising clock edge after the last write data shown at T20.
8. When operating in  $2^tCK$  WRITE preamble mode, CWL may need to be programmed to a value at least 1 clock greater than the lowest CWL setting supported in the applicable  $tCK$  range, which means CWL = 9 is not allowed when operating in  $2^tCK$  WRITE preamble mode.

**Figure 168: WRITE (BC4) OTF to WRITE (BC4) OTF with  $1^tCK$  Preamble in Different Bank Group**



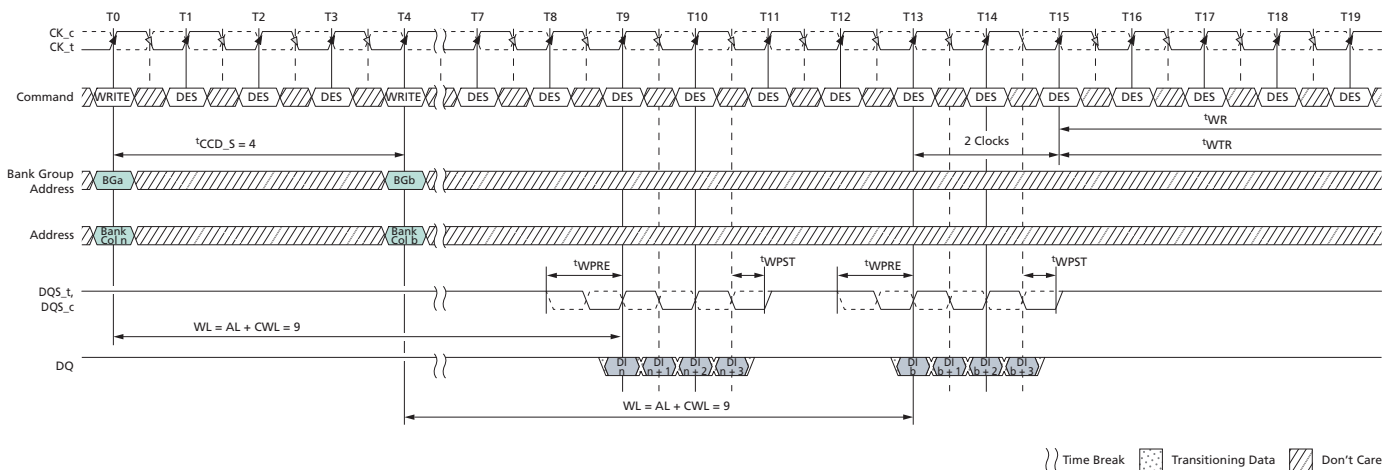
- Notes:
1. BC4, AL = 0, CWL = 9, Preamble =  $1^tCK$ .
  2. DI  $n$  (or  $b$ ) = data-in from column  $n$  (or column  $b$ ).
  3. DES commands are shown for ease of illustration; other commands may be valid at these times.
  4. BC4 setting activated by MR0[1:0] = 01 and A12 = 0 during WRITE commands at T0 and T4.
  5. CA parity = Disable, CS to CA latency = Disable, Write DBI = Disable, Write CRC = Disable.
  6. The write recovery time ( $t_{WR}$ ) and write timing parameter ( $t_{WTR}$ ) are referenced from the first rising clock edge after the last write data shown at T17.

**Figure 169: WRITE (BC4) OTF to WRITE (BC4) OTF with 2<sup>t</sup>CK Preamble in Different Bank Group**



- Notes:
1. BC4, AL = 0, CWL = 9 + 1 = 10 (see Note 7), Preamble = 2<sup>t</sup>CK.
  2. DI *n* (or *b*) = data-in from column *n* (or column *b*).
  3. DES commands are shown for ease of illustration; other commands may be valid at these times.
  4. BC4 setting activated by MR0[1:0] = 01 and A12 = 1 during WRITE commands at T0 and T4.
  5. CA parity = Disable, CS to CA latency = Disable, Write DBI = Disable, Write CRC = Disable.
  6. The write recovery time (t<sub>WR</sub>) and write timing parameter (t<sub>WTR</sub>) are referenced from the first rising clock edge after the last write data shown at T18.
  7. When operating in 2<sup>t</sup>CK WRITE preamble mode, CWL may need to be programmed to a value at least 1 clock greater than the lowest CWL setting supported in the applicable t<sup>t</sup>CK range, which means CWL = 9 is not allowed when operating in 2<sup>t</sup>CK WRITE preamble mode.

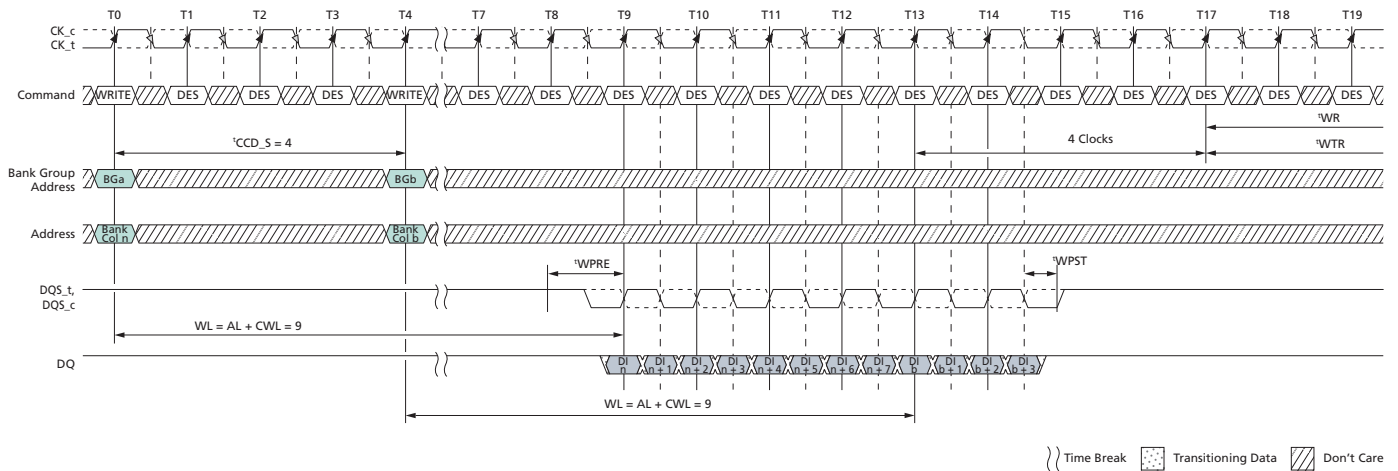
**Figure 170: WRITE (BC4) Fixed to WRITE (BC4) Fixed with 1<sup>t</sup>CK Preamble in Different Bank Group**



- Notes:
1. BC4, AL = 0, CWL = 9, Preamble = 1<sup>t</sup>CK.
  2. DI *n* (or *b*) = data-in from column *n* (or column *b*).

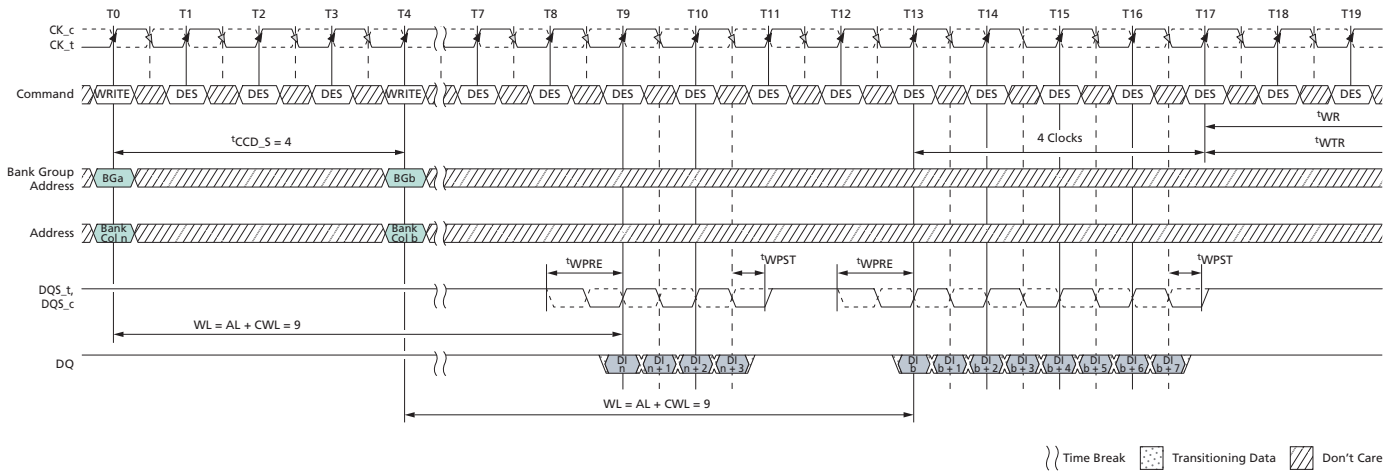
3. DES commands are shown for ease of illustration; other commands may be valid at these times.
4. BC4 (fixed) setting activated by MR0[1:0] = 10.
5. CA parity = Disable, CS to CA latency = Disable, Write DBI = Disable, Write CRC = Disable.
6. The write recovery time ( $t^{\text{WR}}$ ) and write timing parameter ( $t^{\text{WTR}}$ ) are referenced from the first rising clock edge after the last write data shown at T15.

**Figure 171: WRITE (BL8) to WRITE (BC4) OTF with 1<sup>t</sup>CK Preamble in Different Bank Group**



- Notes:
1. BL = 8/BC = 4, AL = 0, CL = 9, Preamble = 1<sup>t</sup>CK.
  2. DI *n* (or *b*) = data-in from column *n* (or column *b*).
  3. DES commands are shown for ease of illustration; other commands may be valid at these times.
  4. BL8 setting activated by MR0[1:0] = 01 and A12 = 1 during WRITE command at T0.  
BC4 setting activated by MR0[1:0] = 01 and A12 = 0 during WRITE command at T4.
  5. CA parity = Disable, CS to CA latency = Disable, Read DBI = Disable, Write CRC = Disable.
  6. The write recovery time ( $t^{\text{WR}}$ ) and write timing parameter ( $t^{\text{WTR}}$ ) are referenced from the first rising clock edge after the last write data shown at T17.

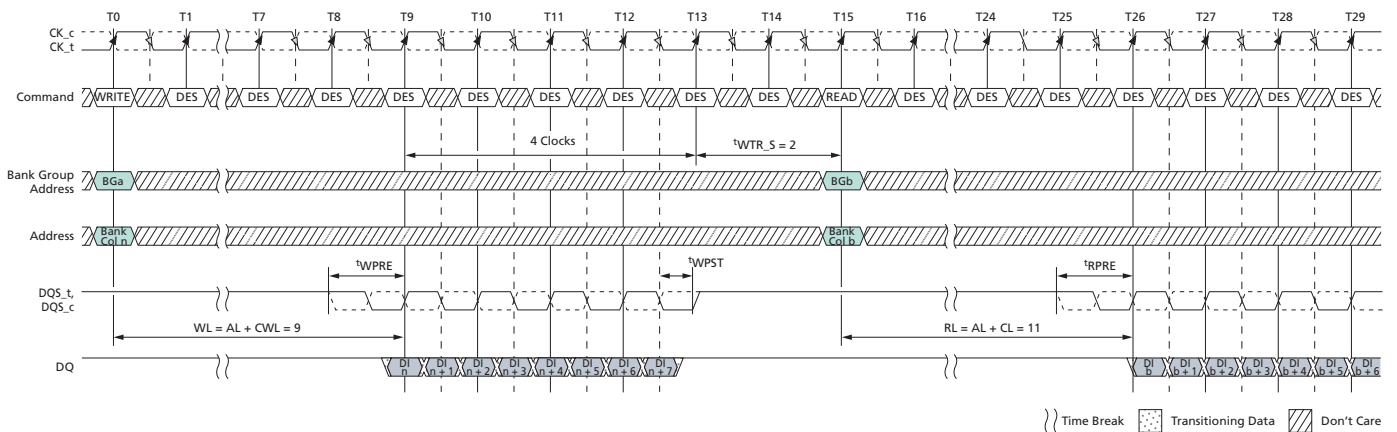
Figure 172: WRITE (BC4) OTF to WRITE (BL8) with 1<sup>t</sup>CK Preamble in Different Bank Group



- Notes:
1. BL = 8/BC = 4, AL = 0, CL = 9, Preamble = 1<sup>t</sup>CK.
  2. DI *n* (or *b*) = data-in from column *n* (or column *b*).
  3. DES commands are shown for ease of illustration; other commands may be valid at these times.
  4. BC4 setting activated by MR0[1:0] = 01 and A12 = 0 during WRITE command at T0.  
BL8 setting activated by MR0[1:0] = 01 and A12 = 1 during WRITE command at T4.
  5. CA parity = Disable, CS to CA latency = Disable, Read DBI = Disable, Write CRC = Disable.
  6. The write recovery time (t<sub>WR</sub>) and write timing parameter (t<sub>WTR</sub>) are referenced from the first rising clock edge after the last write data shown at T17.

## WRITE Operation Followed by READ Operation

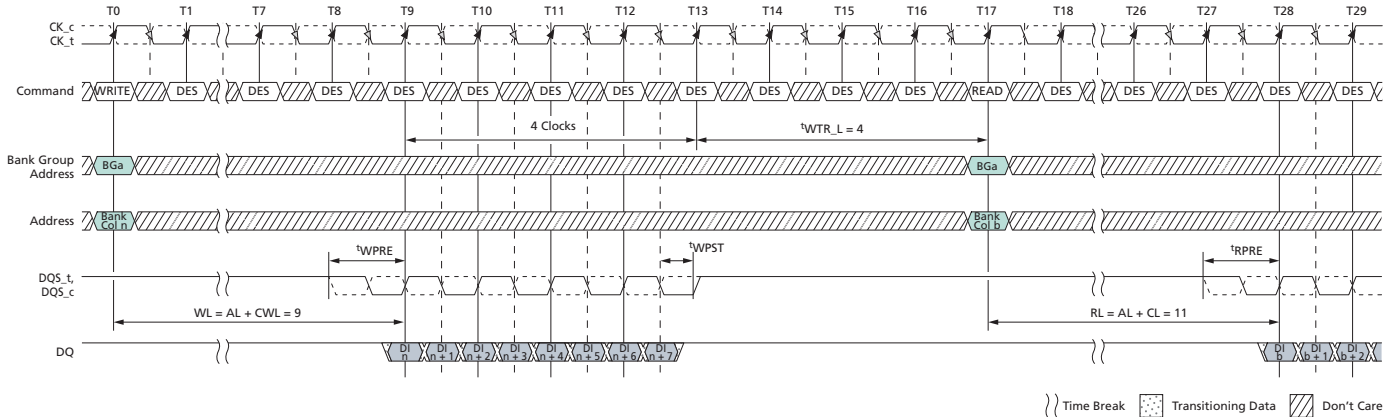
Figure 173: WRITE (BL8) to READ (BL8) with 1<sup>t</sup>CK Preamble in Different Bank Group



- Notes:
1. BL = 8, WL = 9 (CWL = 9, AL = 0), CL = 11, READ preamble = 1<sup>t</sup>CK, WRITE preamble = 1<sup>t</sup>CK.
  2. DI *b* = data-in from column *b*.
  3. DES commands are shown for ease of illustration; other commands may be valid at these times.

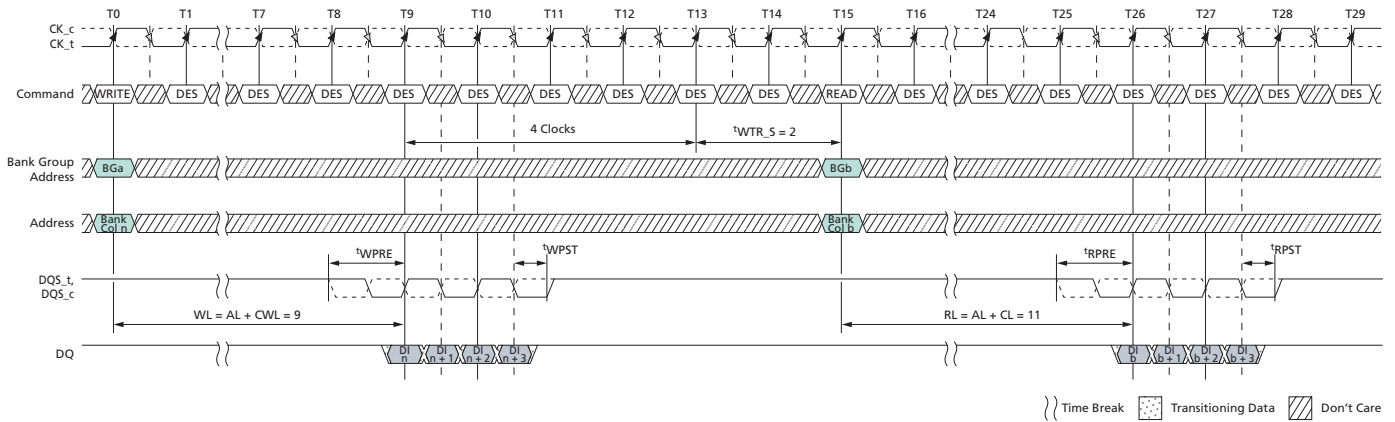
4. BL8 setting activated by either MR0[1:0] = 00 or MR0[1:0] = 01 and A12 = 1 during WRITE command at T0 and READ command at T15.
5. CA parity = Disable, CS to CA latency = Disable, Read DBI = Disable, Write DBI = Disable, Write CRC = Disable.
6. The write timing parameter ( $t^{\text{WTR}}_S$ ) is referenced from the first rising clock edge after the last write data shown at T13.

**Figure 174: WRITE (BL8) to READ (BL8) with 1<sup>t</sup>CK Preamble in Same Bank Group**



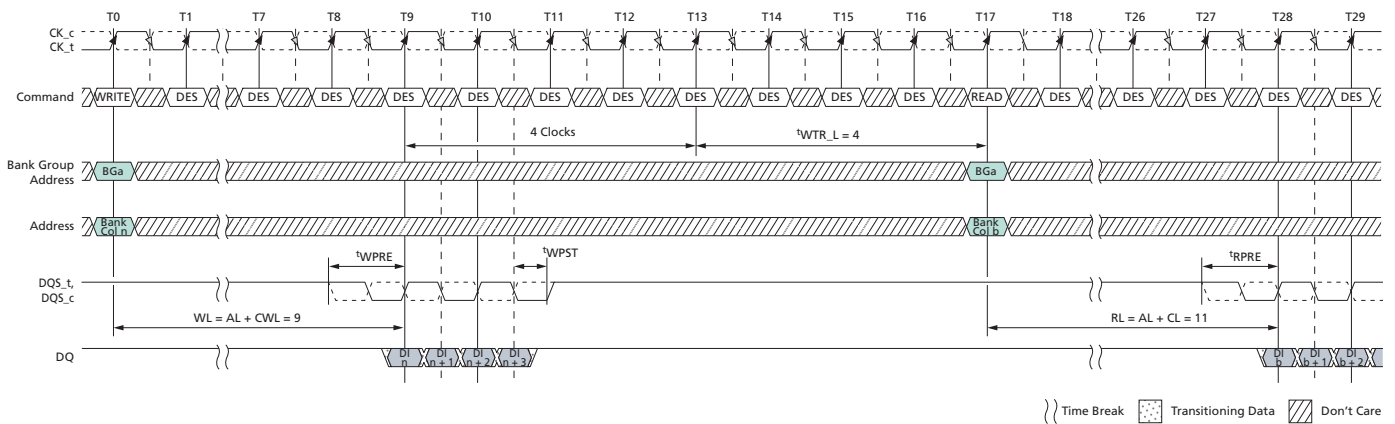
- Notes:
1. BL = 8, WL = 9 (CWL = 9, AL = 0), CL = 11, READ preamble = 1<sup>t</sup>CK, WRITE preamble = 1<sup>t</sup>CK.
  2. DI *b* = data-in from column *b*.
  3. DES commands are shown for ease of illustration; other commands may be valid at these times.
  4. BL8 setting activated by either MR0[1:0] = 00 or MR0[1:0] = 01 and A12 = 1 during WRITE command at T0 and READ command at T17.
  5. CA parity = Disable, CS to CA latency = Disable, Read DBI = Disable, Write DBI = Disable, Write CRC = Disable.
  6. The write timing parameter ( $t^{\text{WTR}}_L$ ) is referenced from the first rising clock edge after the last write data shown at T13.

**Figure 175: WRITE (BC4) OTF to READ (BC4) OTF with 1<sup>t</sup>CK Preamble in Different Bank Group**



- Notes:
1. BC = 4, WL = 9 (CWL = 9, AL = 0), CL = 11, READ preamble = 1<sup>t</sup>CK, WRITE preamble = 1<sup>t</sup>CK.
  2. DI *b* = data-in from column *b*.
  3. DES commands are shown for ease of illustration; other commands may be valid at these times.
  4. BC4 setting activated by MR0[1:0] = 01 and A12 = 0 during WRITE command at T0 and READ command at T15.
  5. CA parity = Disable, CS to CA latency = Disable, Read DBI = Disable, Write DBI = Disable, Write CRC = Disable.
  6. The write timing parameter (<sup>t</sup>WTR\_S) is referenced from the first rising clock edge after the last write data shown at T13.

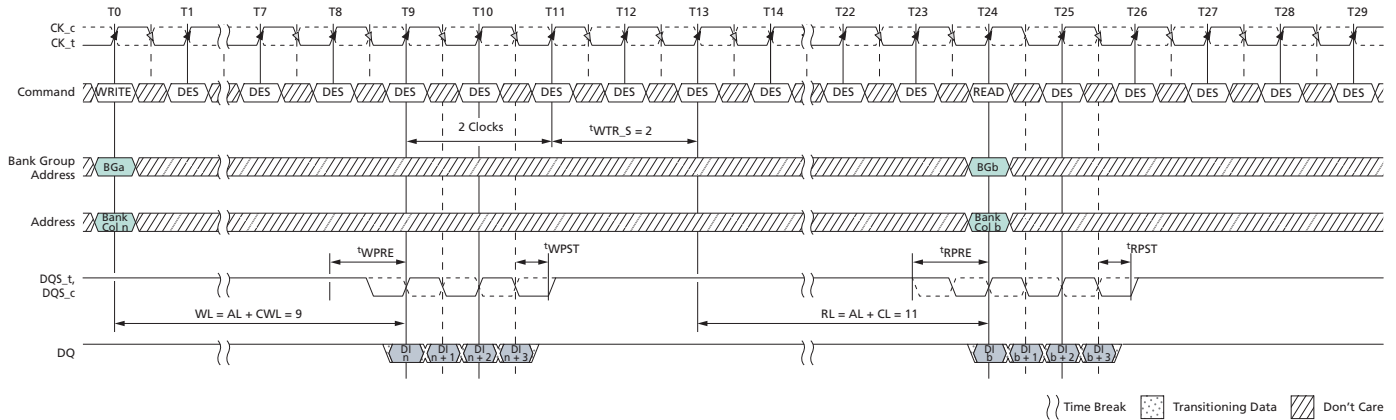
**Figure 176: WRITE (BC4) OTF to READ (BC4) OTF with 1<sup>t</sup>CK Preamble in Same Bank Group**



- Notes:
1. BC = 4, WL = 9 (CWL = 9, AL = 0), CL = 11, READ preamble = 1<sup>t</sup>CK, WRITE preamble = 1<sup>t</sup>CK.
  2. DI *b* = data-in from column *b*.
  3. DES commands are shown for ease of illustration; other commands may be valid at these times.
  4. BC4 setting activated by MR0[1:0] = 01 and A12 = 0 during WRITE command at T0 and READ command at T17.

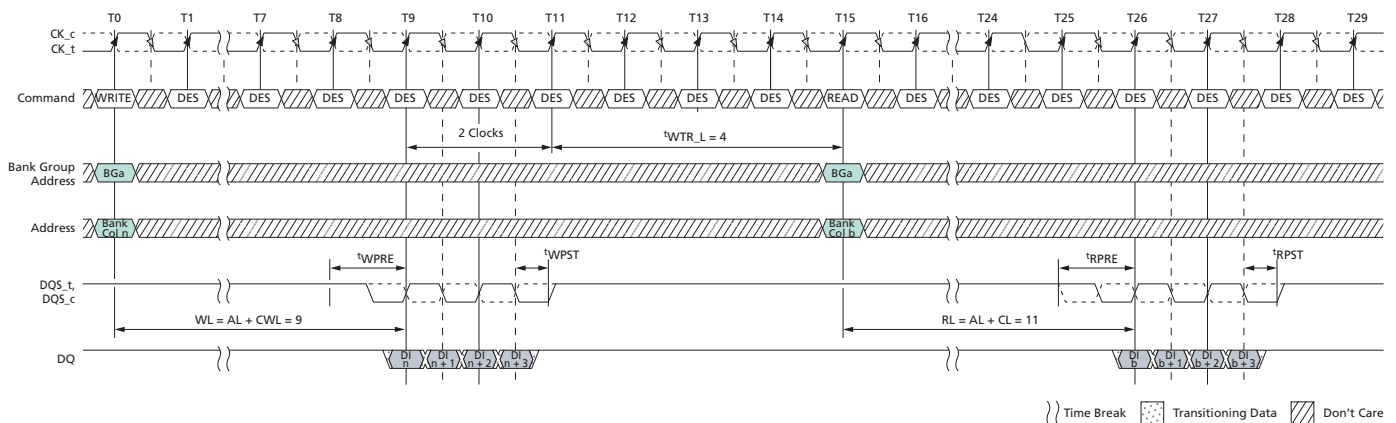
- CA parity = Disable, CS to CA latency = Disable, Read DBI = Disable, Write DBI = Disable, Write CRC = Disable.
- The write timing parameter ( $t^{\text{WTR\_L}}$ ) is referenced from the first rising clock edge after the last write data shown at T13.

**Figure 177: WRITE (BC4) Fixed to READ (BC4) Fixed with 1  $t^{\text{CK}}$  Preamble in Different Bank Group**



- Notes:
- BC = 4, WL = 9 (CWL = 9, AL = 0), CL = 11, READ preamble = 1  $t^{\text{CK}}$ , WRITE preamble = 1  $t^{\text{CK}}$ .
  - DI  $b$  = data-in from column  $b$ .
  - DES commands are shown for ease of illustration; other commands may be valid at these times.
  - BC4 setting activated by MR0[1:0] = 10.
  - CA parity = Disable, CS to CA latency = Disable, Read DBI = Disable, Write DBI = Disable, Write CRC = Disable.
  - The write timing parameter ( $t^{\text{WTR\_S}}$ ) is referenced from the first rising clock edge after the last write data shown at T11.

**Figure 178: WRITE (BC4) Fixed to READ (BC4) Fixed with 1  $t^{\text{CK}}$  Preamble in Same Bank Group**



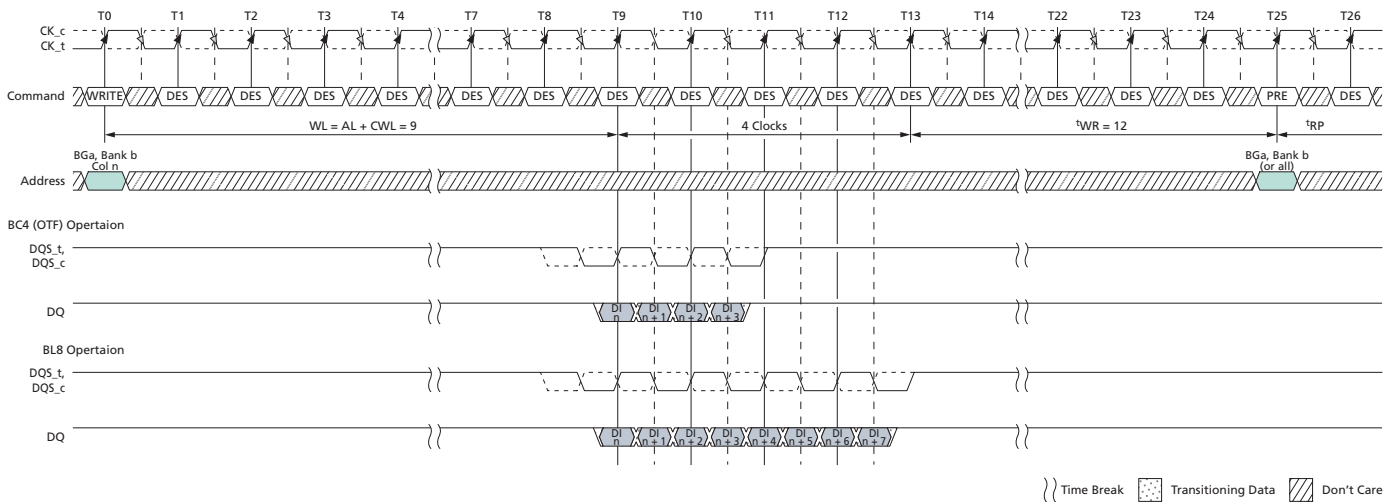
- Notes:
- BC = 4, WL = 9 (CWL = 9, AL = 0), CL = 11, READ preamble = 1  $t^{\text{CK}}$ , WRITE preamble = 1  $t^{\text{CK}}$ .
  - DI  $b$  = data-in from column  $b$ .

- DES commands are shown for ease of illustration; other commands may be valid at these times.
- BC4 setting activated by MR0[1:0] = 10.
- CA parity = Disable, CS to CA latency = Disable, Read DBI = Disable, Write DBI = Disable, Write CRC = Disable.
- The write timing parameter ( $t^{WR}_L$ ) is referenced from the first rising clock edge after the last write data shown at T11.

## WRITE Operation Followed by PRECHARGE Operation

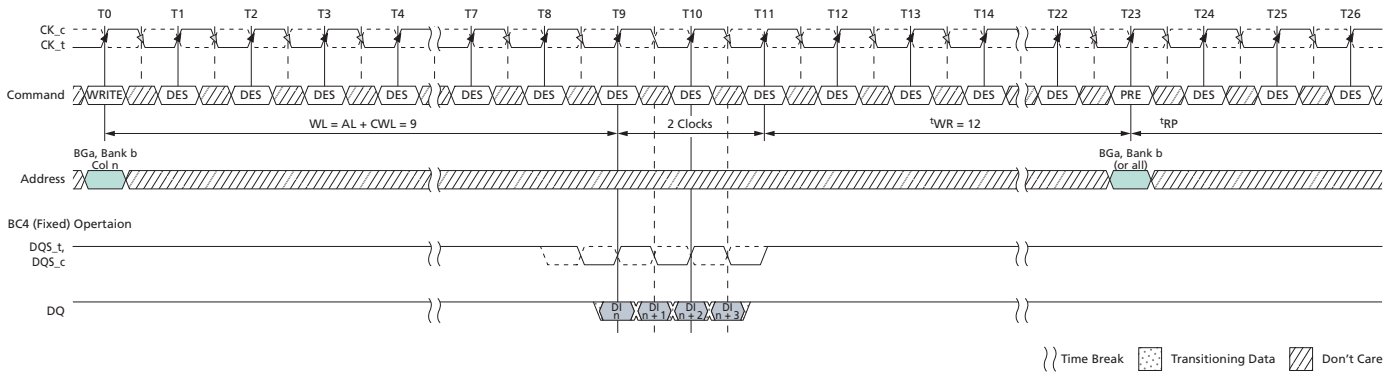
The minimum external WRITE command to PRECHARGE command spacing is equal to WL (AL + CWL) plus either  $4t^{CK}$  (BL8/BC4-OTF) or  $2t^{CK}$  (BC4-fixed) plus  $t^{WR}$ . The minimum ACT to PRE timing,  $t^{RAS}$ , must be satisfied as well.

**Figure 179: WRITE (BL8/BC4-OTF) to PRECHARGE with  $1t^{CK}$  Preamble**



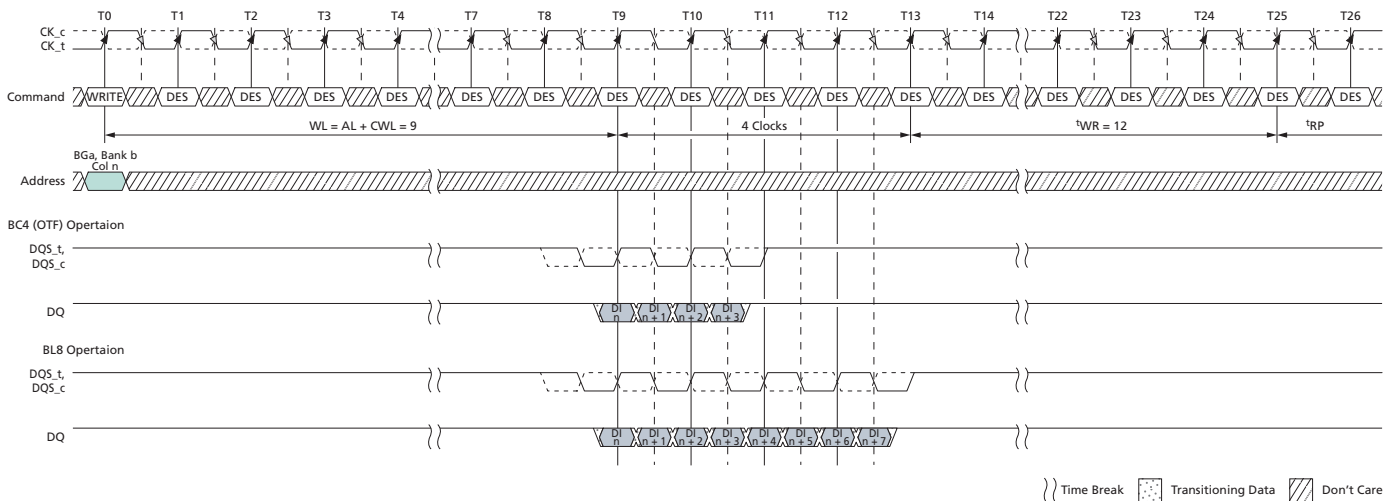
- Notes:
- BL = 8 with BC4-OTF, WL = 9 (CWL = 9, AL = 0), Preamble =  $1t^{CK}$ ,  $t^{WR} = 12$ .
  - DI  $n$  = data-in from column  $n$ .
  - DES commands are shown for ease of illustration; other commands may be valid at these times.
  - BC4 setting activated by MR0[1:0] = 01 and A12 = 0 during WRITE command at T0. BL8 setting activated by MR0[1:0] = 00 or MR0[1:0] = 01 and A12 = 1 during WRITE command at T0.
  - CA parity = Disable, CS to CA latency = Disable, Read DBI = Disable, CRC = Disable.
  - The write recovery time ( $t^{WR}$ ) is referenced from the first rising clock edge after the last write data shown at T13.  $t^{WR}$  specifies the last burst WRITE cycle until the PRECHARGE command can be issued to the same bank.

**Figure 180: WRITE (BC4-Fixed) to PRECHARGE with 1<sup>t</sup>CK Preamble**



- Notes:
1. BC4 = fixed, WL = 9 (CWL = 9, AL = 0), Preamble = 1<sup>t</sup>CK, <sup>t</sup>WR = 12.
  2. DI *n* = data-in from column *n*.
  3. DES commands are shown for ease of illustration; other commands may be valid at these times.
  4. BC4 setting activated by MR0[1:0] = 10.
  5. CA parity = Disable, CS to CA latency = Disable, Read DBI = Disable, CRC = Disable.
  6. The write recovery time (<sup>t</sup>WR) is referenced from the first rising clock edge after the last write data shown at T11. <sup>t</sup>WR specifies the last burst WRITE cycle until the PRECHARGE command can be issued to the same bank.

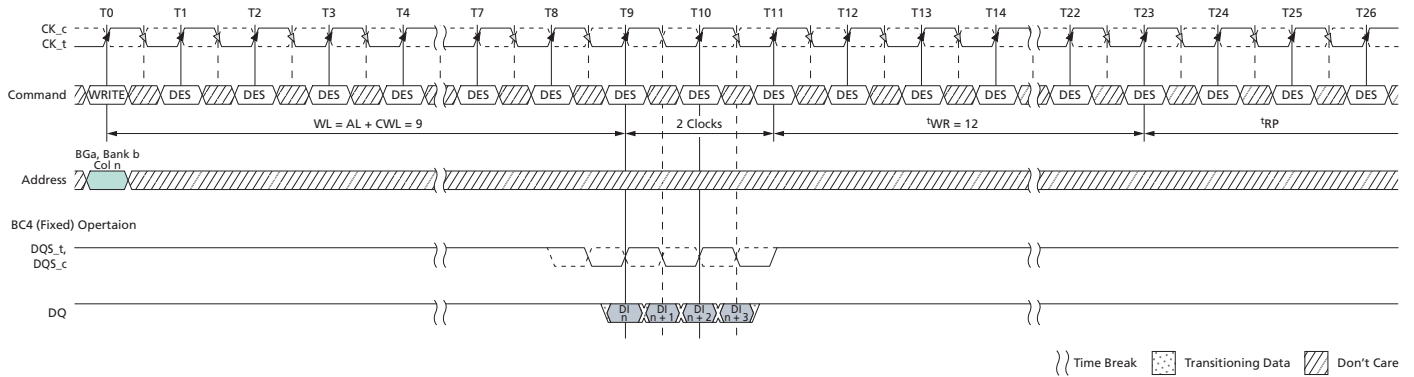
**Figure 181: WRITE (BL8/BC4-OTF) to Auto PRECHARGE with 1<sup>t</sup>CK Preamble**



- Notes:
1. BL = 8 with BC4-OTF, WL = 9 (CWL = 9, AL = 0), Preamble = 1<sup>t</sup>CK, <sup>t</sup>WR = 12.
  2. DI *n* = data-in from column *n*.
  3. DES commands are shown for ease of illustration; other commands may be valid at these times.
  4. BC4 setting activated by MR0[1:0] = 01 and A12 = 0 during WRITE command at T0. BL8 setting activated by MR0[1:0] = 00 or MR0[1:0] = 01 and A12 = 1 during WRITE command at T0.
  5. CA parity = Disable, CS to CA latency = Disable, Read DBI = Disable, CRC = Disable.

- The write recovery time ( $t_{WR}$ ) is referenced from the first rising clock edge after the last write data shown at T13.  $t_{WR}$  specifies the last burst WRITE cycle until the PRECHARGE command can be issued to the same bank.

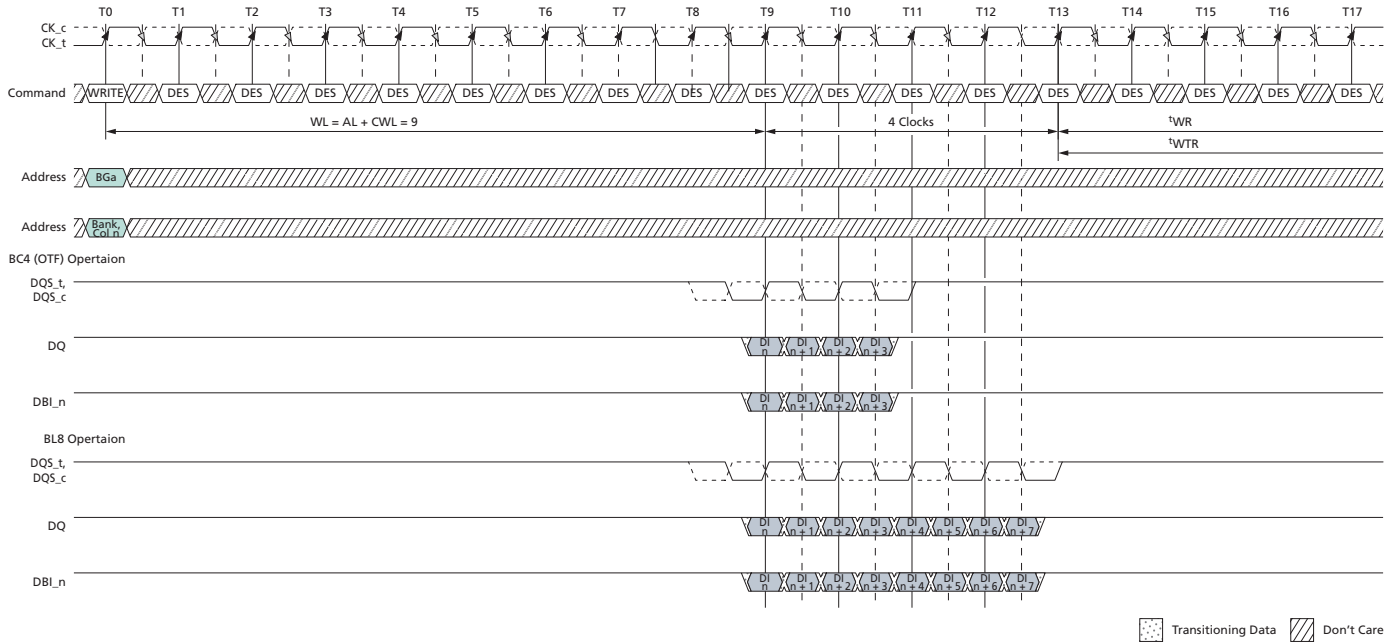
**Figure 182: WRITE (BC4-Fixed) to Auto PRECHARGE with  $1^t$ CK Preamble**



- Notes:
- BC4 = fixed, WL = 9 (CWL = 9, AL = 0), Preamble =  $1^t$ CK,  $t_{WR} = 12$ .
  - DI  $n$  = data-in from column  $n$ .
  - DES commands are shown for ease of illustration; other commands may be valid at these times.
  - BC4 setting activated by MR0[1:0] = 10.
  - CA parity = Disable, CS to CA latency = Disable, Read DBI = Disable, CRC = Disable.
  - The write recovery time ( $t_{WR}$ ) is referenced from the first rising clock edge after the last write data shown at T11.  $t_{WR}$  specifies the last burst WRITE cycle until the PRECHARGE command can be issued to the same bank.

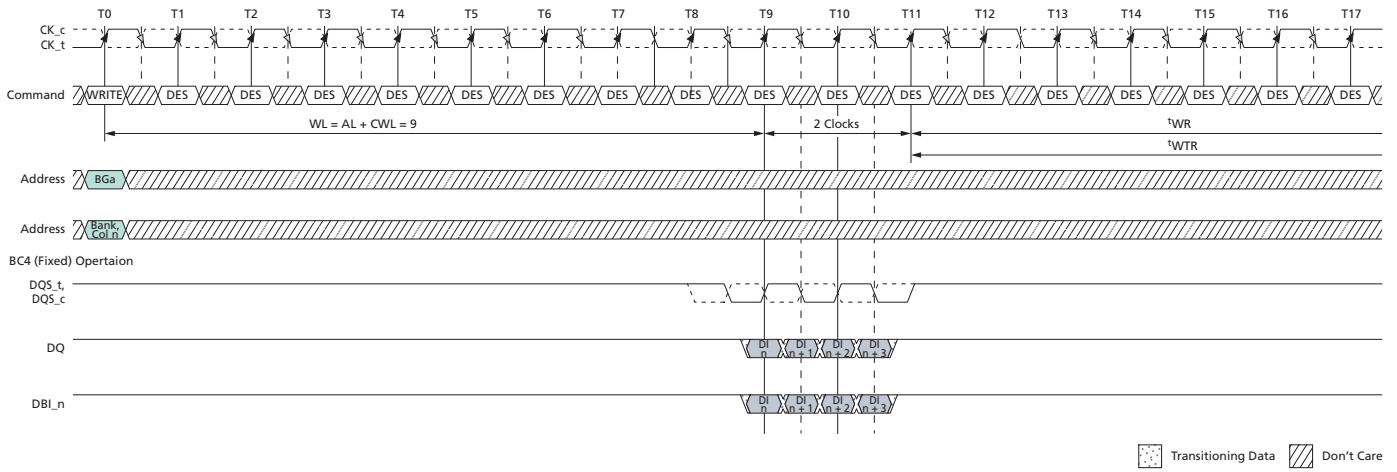
## WRITE Operation with WRITE DBI Enabled

Figure 183: WRITE (BL8/BC4-OTF) with 1<sup>t</sup>CK Preamble and DBI



- Notes:
1. BL = 8 with BC4-OTF, WL = 9 (CWL = 9, AL = 0), Preamble = 1<sup>t</sup>CK.
  2. DI  $n$  = data-in from column  $n$ .
  3. DES commands are shown for ease of illustration; other commands may be valid at these times.
  4. BC4 setting activated by MR0[1:0] = 01 and A12 = 0 during WRITE command at T0.  
BL8 setting activated by MR0[1:0] = 00 or MR0[1:0] = 01 and A12 = 1 during WRITE command at T0.
  5. CA parity = Disable, CS to CA latency = Disable, Write DBI = Enabled, Write CRC = Disabled.
  6. The write recovery time ( $t_{WR\_DBI}$ ) is referenced from the first rising clock edge after the last write data shown at T13.

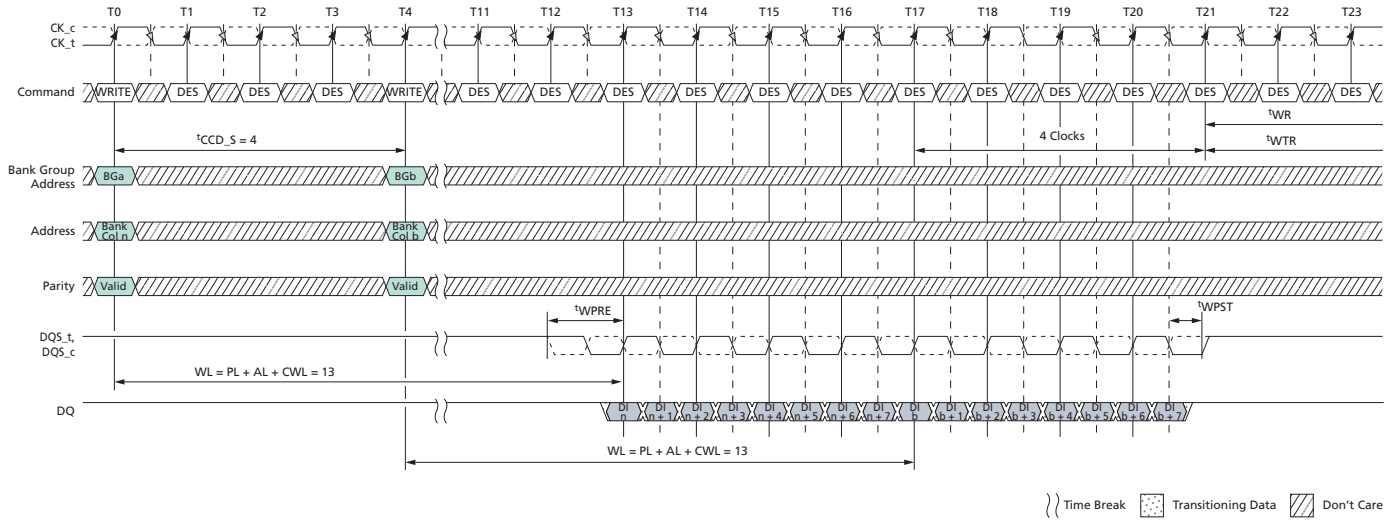
**Figure 184: WRITE (BC4-Fixed) with 1<sup>t</sup>CK Preamble and DBI**



- Notes:
1. BC4 = fixed, WL = 9 (CWL = 9, AL = 0), Preamble = 1<sup>t</sup>CK.
  2. DI *n* = data-in from column *n*.
  3. DES commands are shown for ease of illustration; other commands may be valid at these times.
  4. BC4 setting activated by MR0[1:0] = 10.
  5. CA parity = Disable, CS to CA latency = Disable, Write DBI = Enabled, Write CRC = Disabled.

WRITE Operation with CA Parity Enabled

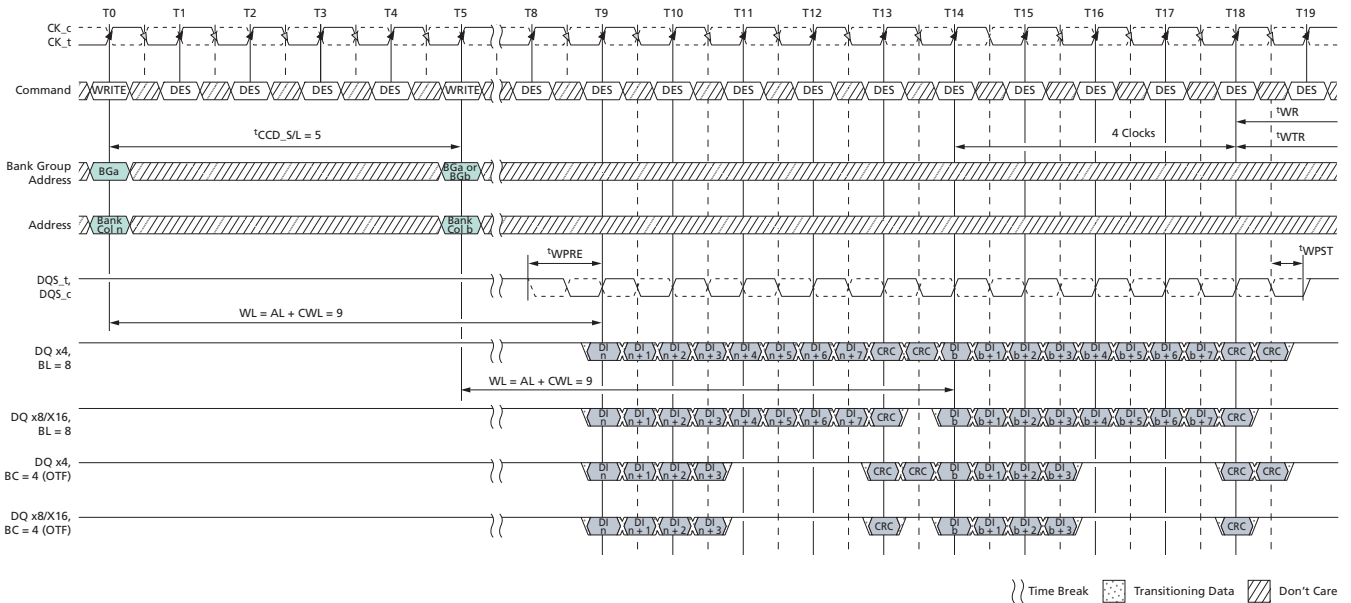
Figure 185: Consecutive Write (BL8) with 1<sup>t</sup>CK Preamble and CA Parity in Different Bank Group



- Notes:
1. BL = 8, WL = 9 (CWL = 13, AL = 0), Preamble = 1<sup>t</sup>CK.
  2. DI *n* = data-in from column *n*.
  3. DES commands are shown for ease of illustration; other commands may be valid at these times.
  4. BL8 setting activated by MR0[1:0] = 00 or MR0[1:0] = 01 and A12 = 1 during WRITE commands at T0 and T4.
  5. CA parity = Enable, CS to CA latency = Disable, Write DBI = Enabled, Write CRC = Disable.
  6. The write recovery time (t<sub>WTR</sub>) and write timing parameter (t<sub>WPST</sub>) are referenced from the first rising clock edge after the last write data shown at T21.

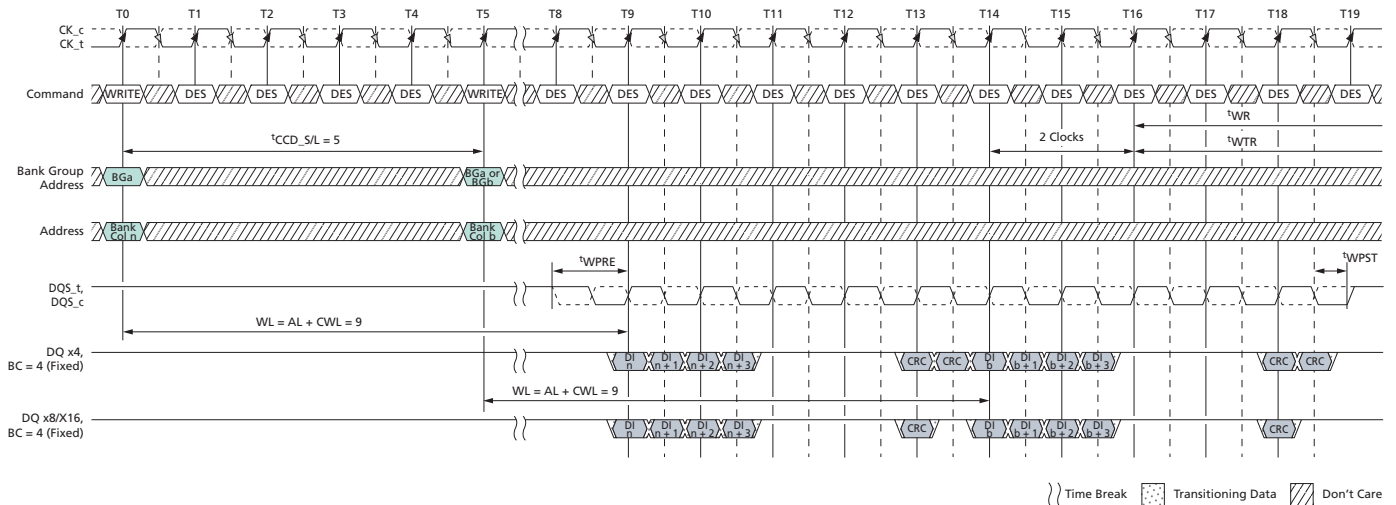
WRITE Operation with Write CRC Enabled

Figure 186: Consecutive WRITE (BL8/BC4-OTF) with 1<sup>t</sup>CK Preamble and Write CRC in Same or Different Bank Group



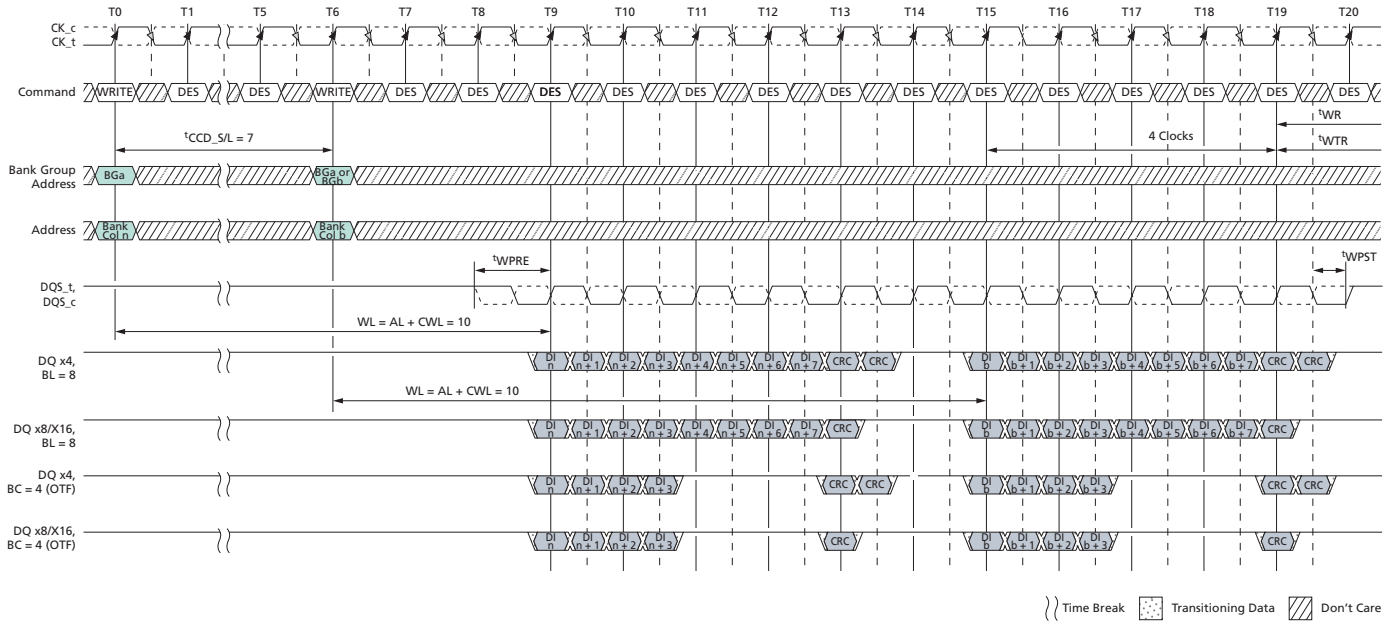
- Notes:
1. BL8/BC4-OTF, AL = 0, CWL = 9, Preamble = 1<sup>t</sup>CK, t<sup>CDD\_S/L</sup> = 5<sup>t</sup>CK.
  2. DI *n* (or *b*) = data-in from column *n* (or column *b*).
  3. DES commands are shown for ease of illustration; other commands may be valid at these times.
  4. BL8 setting activated by either MR0[1:0] = 00 or MR0[1:0] = 01 and A12 = 1 during WRITE commands at T0 and T5.
  5. BC4 setting activated by MR0[1:0] = 01 and A12 = 0 during WRITE commands at T0 and T5.
  6. CA parity = Disable, CS to CA latency = Disable, Read DBI = Disable, Write CRC = Enable.
  7. The write recovery time (t<sup>WR</sup>) and write timing parameter (t<sup>WTR</sup>) are referenced from the first rising clock edge after the last write data shown at T18.

**Figure 187: Consecutive WRITE (BC4-Fixed) with 1<sup>t</sup>CK Preamble and Write CRC in Same or Different Bank Group**



- Notes:
1. BC4-fixed, AL = 0, CWL = 9, Preamble = 1<sup>t</sup>CK, t<sup>CCD\_S/L</sup> = 5<sup>t</sup>CK.
  2. DI *n* (or *b*) = data-in from column *n* (or column *b*).
  3. DES commands are shown for ease of illustration; other commands may be valid at these times.
  4. BC4 setting activated by MR0[1:0] = 10 during WRITE commands at T0 and T5.
  5. CA parity = Disable, CS to CA latency = Disable, Read DBI = Disable, Write CRC = Enable, DM = Disable.
  6. The write recovery time (t<sup>WR</sup>) and write timing parameter (t<sup>WTR</sup>) are referenced from the first rising clock edge after the last write data shown at T16.

**Figure 188: Nonconsecutive WRITE (BL8/BC4-OTF) with 1<sup>st</sup>CK Preamble and Write CRC in Same or Different Bank Group**



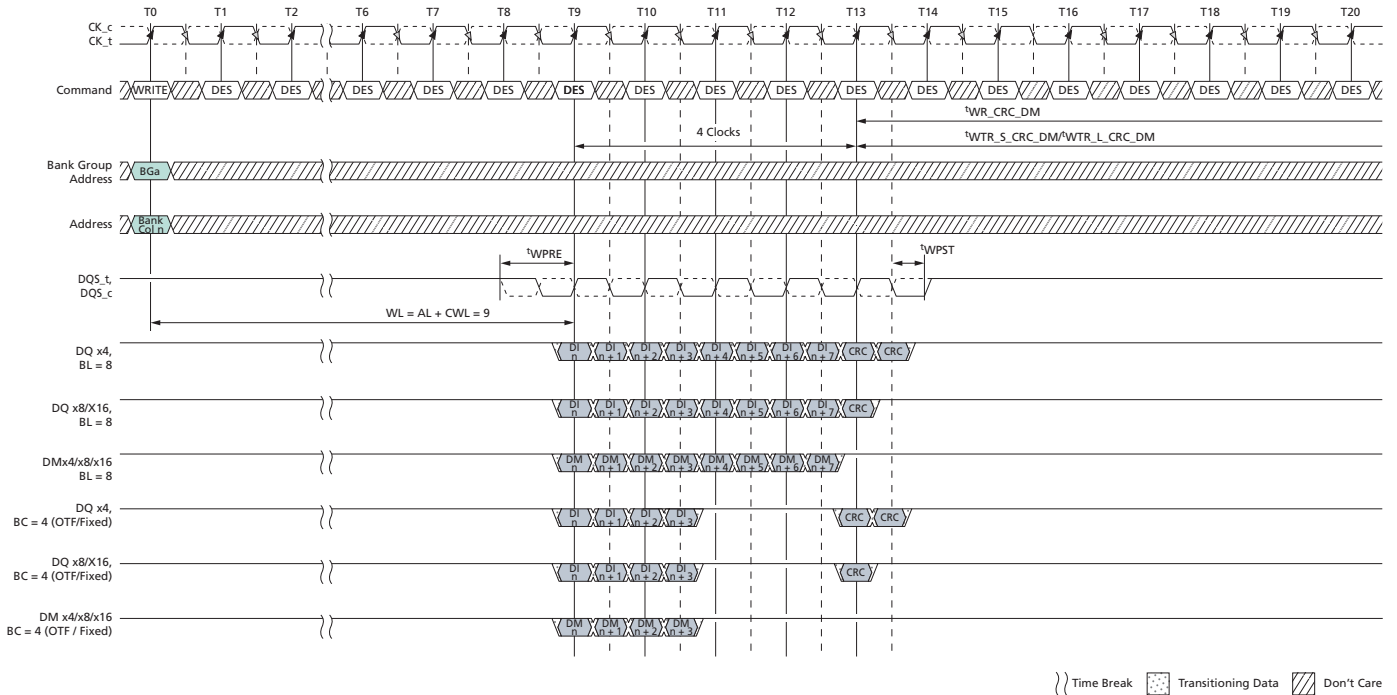
- Notes:
1. BL8/BC4-OTF, AL = 0, CWL = 9, Preamble = 1<sup>st</sup>CK, t<sup>CCD\_S/L</sup> = 6<sup>st</sup>CK.
  2. DI *n* (or *b*) = data-in from column *n* (or column *b*).
  3. DES commands are shown for ease of illustration; other commands may be valid at these times.
  4. BL8 setting activated by either MR0[1:0] = 00 or MR0[1:0] = 01 and A12 = 1 during WRITE commands at T0 and T6.
  5. BC4 setting activated by MR0[1:0] = 01 and A12 = 0 during WRITE commands at T0 and T6.
  6. CA parity = Disable, CS to CA latency = Disable, Read DBI = Disable, Write CRC = Enable, DM = Disable.
  7. The write recovery time (t<sup>WR</sup>) and write timing parameter (t<sup>WTR</sup>) are referenced from the first rising clock edge after the last write data shown at T19.

**Figure 189: Nonconsecutive WRITE (BL8/BC4-OTF) with 2<sup>t</sup>CK Preamble and Write CRC in Same or Different Bank Group**



- Notes:
1. BL8/BC4-OTF, AL = 0, CWL = 9 + 1 = 10 (see Note 9), Preamble = 2<sup>t</sup>CK, tCDD\_S/L = 7<sup>t</sup>CK (see Note 7).
  2. DI *n* (or *b*) = data-in from column *n* (or column *b*).
  3. DES commands are shown for ease of illustration; other commands may be valid at these times.
  4. BL8 setting activated by either MR0[1:0] = 00 or MR0[1:0] = 01 and A12 = 1 during WRITE commands at T0 and T7.
  5. BC4 setting activated by MR0[1:0] = 01 and A12 = 0 during WRITE commands at T0 and T7.
  6. CA parity = Disable, CS to CA latency = Disable, Read DBI = Disable, Write CRC = Enable, DM = Disable.
  7. tCDD\_S/L = 6<sup>t</sup>CK is not allowed in 2<sup>t</sup>CK preamble mode.
  8. The write recovery time (tWR) and write timing parameter (tWTR) are referenced from the first rising clock edge after the last write data shown at T21.
  9. When operating in 2<sup>t</sup>CK WRITE preamble mode, CWL may need to be programmed to a value at least 1 clock greater than the lowest CWL setting supported in the applicable tCK range. That means CWL = 9 is not allowed when operating in 2<sup>t</sup>CK WRITE preamble mode.

Figure 190: WRITE (BL8/BC4-OTF/Fixed) with 1<sup>t</sup>CK Preamble and Write CRC in Same or Different Bank Group



- Notes:
1. BL8/BC4, AL = 0, CWL = 9, Preamble = 1<sup>t</sup>CK.
  2. DI *n* (or *b*) = data-in from column *n* (or column *b*).
  3. DES commands are shown for ease of illustration; other commands may be valid at these times.
  4. BL8 setting activated by either MR0[1:0] = 00 or MR0[1:0] = 01 and A12 = 1 during WRITE command at T0.
  5. BC4 setting activated by either MR0[1:0] = 10 or MR0[1:0] = 01 and A12 = 0 during WRITE command at T0.
  6. CA parity = Disable, CS to CA latency = Disable, Read DBI = Disable, Write CRC = Enable, DM = Enable.
  7. The write recovery time ( $t_{WR\_CRC\_DM}$ ) and write timing parameter ( $t_{WTR\_S\_CRC\_DM}/t_{WTR\_L\_CRC\_DM}$ ) are referenced from the first rising clock edge after the last write data shown at T13.

## Write Timing Violations

### Motivation

Generally, if timing parameters are violated, a complete reset/initialization procedure has to be initiated to make sure that the device works properly. However, for certain minor violations, it is desirable that the device is guaranteed not to "hang up" and that errors are limited to that specific operation. A minor violation does not include a major timing violation (for example, when a DQS strobe misses in the  $t_{DQSCK}$  window).

For the following, it will be assumed that there are no timing violations with regard to the WRITE command itself (including ODT, and so on) and that it does satisfy all timing requirements not mentioned below.

### Data Setup and Hold Violations

If the data-to-strobe timing requirements ( $t_{DS}$ ,  $t_{DH}$ ) are violated, for any of the strobe edges associated with a WRITE burst, then wrong data might be written to the memory location addressed with this WRITE command.

In the example, the relevant strobe edges for WRITE Burst A are associated with the clock edges: T5, T5.5, T6, T6.5, T7, T7.5, T8, and T8.5.

Subsequent reads from that location might result in unpredictable read data; however, the device will work properly otherwise.

### Strobe-to-Strobe and Strobe-to-Clock Violations

If the strobe timing requirements ( $t_{DQSH}$ ,  $t_{DQSL}$ ,  $t_{WPRE}$ ,  $t_{WPST}$ ) or the strobe to clock timing requirements ( $t_{DSS}$ ,  $t_{DSH}$ ,  $t_{DQSS}$ ) are violated, for any of the strobe edges associated with a WRITE burst, then wrong data might be written to the memory location addressed with the offending WRITE command. Subsequent reads from that location might result in unpredictable read data; however, the device will work properly otherwise with the following constraints:

- Both write CRC and data burst OTF are disabled; timing specifications other than  $t_{DQSH}$ ,  $t_{DQSL}$ ,  $t_{WPRE}$ ,  $t_{WPST}$ ,  $t_{DSS}$ ,  $t_{DSH}$ ,  $t_{DQSS}$  are not violated.
- The offending write strobe (and preamble) arrive no earlier or later than six DQS transition edges from the WRITE latency position.
- A READ command following an offending WRITE command from any open bank is allowed.
- One or more subsequent WR or a subsequent WRA (to same bank as offending WR) may be issued  $t_{CCD\_L}$  later, but incorrect data could be written. Subsequent WR and WRA can be either offending or non-offending writes. Reads from these writes may provide incorrect data.
- One or more subsequent WR or a subsequent WRA (to a different bank group) may be issued  $t_{CCD\_S}$  later, but incorrect data could be written. Subsequent WR and WRA can be either offending or non-offending writes. Reads from these writes may provide incorrect data.
- After one or more precharge commands (PRE or PREA) are issued to the device after an offending WRITE command and all banks are in precharged state (idle state), a subsequent, non-offending WR or WRA to any open bank will be able to write correct data.

## ZQ CALIBRATION Commands

A ZQ CALIBRATION command is used to calibrate DRAM  $R_{ON}$  and ODT values. The device needs a longer time to calibrate the output driver and on-die termination circuits at initialization and a relatively smaller time to perform periodic calibrations.

The ZQCL command is used to perform the initial calibration during the power-up initialization sequence. This command may be issued at any time by the controller depending on the system environment. The ZQCL command triggers the calibration engine inside the DRAM and, after calibration is achieved, the calibrated values are transferred from the calibration engine to DRAM I/O, which is reflected as an updated output driver and ODT values.

The first ZQCL command issued after reset is allowed a timing period of  $t_{ZQinit}$  to perform the full calibration and the transfer of values. All other ZQCL commands except the first ZQCL command issued after reset are allowed a timing period of  $t_{ZQoper}$ .

The ZQCS command is used to perform periodic calibrations to account for voltage and temperature variations. A shorter timing window is provided to perform the calibration and transfer of values as defined by timing parameter  $t_{ZQCS}$ . One ZQCS command can effectively correct a minimum of 0.5 % (ZQ correction) of  $R_{ON}$  and  $R_{TT}$  impedance error within  $64 nCK$  for all speed bins assuming the maximum sensitivities specified in the Output Driver and ODT Voltage and Temperature Sensitivity tables. The appropriate interval between ZQCS commands can be determined from these tables and other application-specific parameters. One method for calculating the interval between ZQCS commands, given the temperature ( $T_{driftrate}$ ) and voltage ( $V_{driftrate}$ ) drift rates that the device is subjected to in the application, is illustrated. The interval could be defined by the following formula:

$$\frac{ZQ_{correction}}{R(T_{sens} \times T_{driftrate}) + (V_{sens} \times V_{driftrate})}$$

Where  $T_{sens} = \text{MAX}(dR_{TT}dT, dR_{ON}dTM)$  and  $V_{sens} = \text{MAX}(dR_{TT}dV, dR_{ON}dVM)$  define the temperature and voltage sensitivities.

For example, if  $T_{sens} = 1.5\%/^{\circ}C$ ,  $V_{sens} = 0.15\%/mV$ ,  $T_{driftrate} = 1^{\circ}C/sec$  and  $V_{driftrate} = 15 mV/sec$ , then the interval between ZQCS commands is calculated as:

$$\frac{0.5}{(1.5 \times 1) + (0.15 \times 15)} = 0.133 \approx 128ms$$

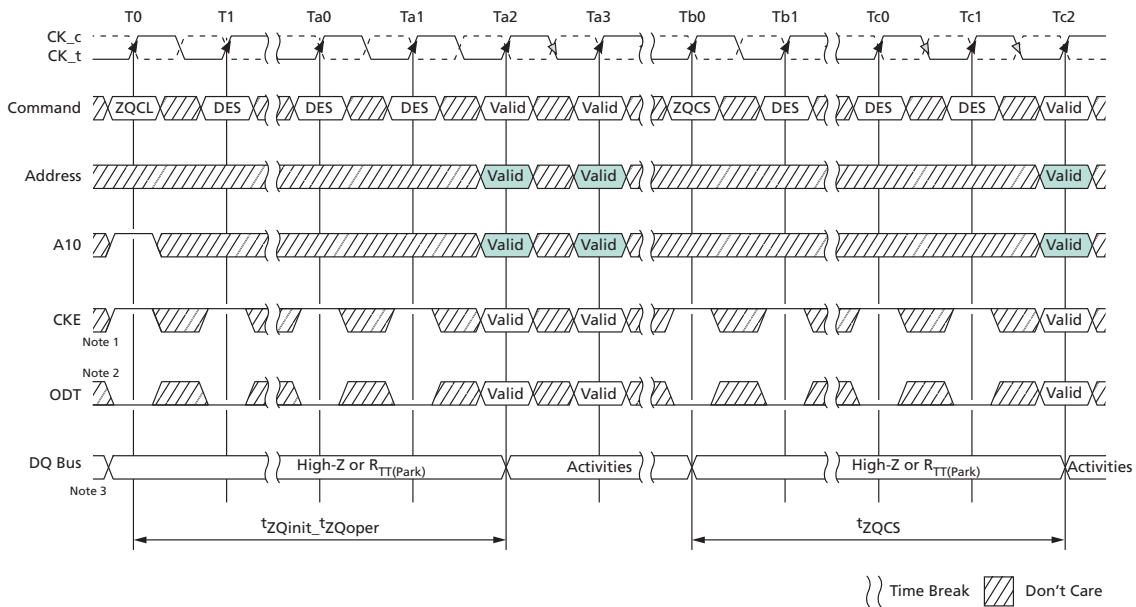
No other activities should be performed on the DRAM channel by the controller for the duration of  $t_{ZQinit}$ ,  $t_{ZQoper}$ , or  $t_{ZQCS}$ . The quiet time on the DRAM channel allows accurate calibration of output driver and on-die termination values. After DRAM calibration is achieved, the device should disable the ZQ current consumption path to reduce power.

All banks must be precharged and  $t_{RP}$  met before ZQCL or ZQCS commands are issued by the controller.

ZQ CALIBRATION commands can also be issued in parallel to DLL lock time when coming out of self refresh. Upon self refresh exit, the device will not perform an I/O calibration without an explicit ZQ CALIBRATION command. The earliest possible time for a ZQ CALIBRATION command (short or long) after self refresh exit is  $t^{\text{XSE}}$ .

In systems that share the ZQ resistor between devices, the controller must not allow any overlap of  $t^{\text{ZQoper}}$ ,  $t^{\text{ZQinit}}$ , or  $t^{\text{ZQCS}}$  between the devices.

**Figure 191: ZQ Calibration Timing**



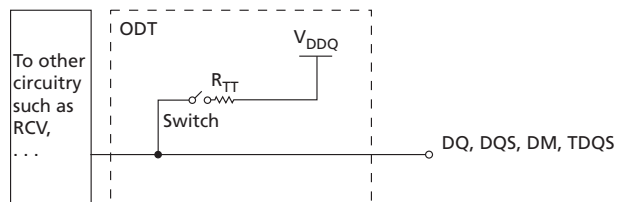
- Notes:
1. CKE must be continuously registered HIGH during the calibration procedure.
  2. On-die termination must be disabled via the ODT signal or MRS during the calibration procedure or the DRAM will automatically disable  $R_{\text{TT1}}$ .
  3. All devices connected to the DQ bus should be High-Z during the calibration procedure.

## On-Die Termination

On-die termination (ODT) is a feature that enables the device to change termination resistance for each DQ, DQS, and DM\_n signal for x4 and x8 configurations (and TDQS for the x8 configuration, when enabled via A11 = 1 in MR1) via the ODT control pin, WRITE command, or default parking value with MR setting. For the x16 configuration, ODT is applied to each DQU, DQL, DQSU, DQSL, DMU\_n, and DML\_n signal. The ODT feature is designed to improve the signal integrity of the memory channel by allowing the DRAM controller to independently change termination resistance for any or all DRAM devices. More details about ODT control modes and ODT timing modes can be found further along in this document.

The ODT feature is turned off and not supported in self refresh mode.

**Figure 192: Functional Representation of ODT**



The switch is enabled by the internal ODT control logic, which uses the external ODT pin and other control information. The value of  $R_{TT}$  is determined by the settings of mode register bits (see Mode Register). The ODT pin will be ignored if the mode register MR1 is programmed to disable  $R_{TT(NOM)}$  [MR1[9,6,2] = 0,0,0] and in self refresh mode.

## ODT Mode Register and ODT State Table

The ODT mode of the DDR4 device has four states: data termination disable,  $R_{TT(NOM)}$ ,  $R_{TT(WR)}$ , and  $R_{TT(Park)}$ . The ODT mode is enabled if any of MR1[10:8] ( $R_{TT(NOM)}$ ), MR2[11:9] ( $R_{TT(WR)}$ ), or MR5[8:6] ( $R_{TT(Park)}$ ) are non-zero. When enabled, the value of  $R_{TT}$  is determined by the settings of these bits.

$R_{TT}$  control of each  $R_{TT}$  condition is possible with a WR or RD command and ODT pin.

- $R_{TT(WR)}$ : The DRAM (rank) that is being written to provide termination regardless of ODT pin status (either HIGH or LOW).
- $R_{TT(NOM)}$ : DRAM turns ON  $R_{TT(NOM)}$  if it sees ODT asserted HIGH (except when ODT is disabled by MR1).
- $R_{TT(Park)}$ : Default parked value set via MR5 to be enabled and  $R_{TT(NOM)}$  is not turned on.
- The Termination State Table that follows shows various interactions.

The  $R_{TT}$  values have the following priority:

- Data termination disable
- $R_{TT(WR)}$
- $R_{TT(NOM)}$
- $R_{TT(Park)}$

**Table 67: Termination State Table**

Case	R <sub>TT(Park)</sub>	R <sub>TT(NOM)</sub> <sup>1</sup>	R <sub>TT(WR)</sub> <sup>2</sup>	ODT Pin	ODT READS <sup>3</sup>	ODT Standby	ODT WRITES
A <sup>4</sup>	Disabled	Disabled	Disabled	Don't Care	Off (High-Z)	Off (High-Z)	Off (High-Z)
			Enabled	Don't Care	Off (High-Z)	Off (High-Z)	R <sub>TT(WR)</sub>
B <sup>5</sup>	Enabled	Disabled	Disabled	Don't Care	Off (High-Z)	R <sub>TT(Park)</sub>	R <sub>TT(Park)</sub>
			Enabled	Don't Care	Off (High-Z)	R <sub>TT(Park)</sub>	R <sub>TT(WR)</sub>
C <sup>6</sup>	Disabled	Enabled	Disabled	Low	Off (High-Z)	Off (High-Z)	Off (High-Z)
				High	Off (High-Z)	R <sub>TT(NOM)</sub>	R <sub>TT(NOM)</sub>
			Enabled	Low	Off (High-Z)	Off (High-Z)	R <sub>TT(WR)</sub>
				High	Off (High-Z)	R <sub>TT(NOM)</sub>	R <sub>TT(WR)</sub>
D <sup>6</sup>	Enabled	Enabled	Disabled	Low	Off (High-Z)	R <sub>TT(Park)</sub>	R <sub>TT(Park)</sub>
				High	Off (High-Z)	R <sub>TT(NOM)</sub>	R <sub>TT(NOM)</sub>
			Enabled	Low	Off (High-Z)	R <sub>TT(Park)</sub>	R <sub>TT(WR)</sub>
				High	Off (High-Z)	R <sub>TT(NOM)</sub>	R <sub>TT(WR)</sub>

- Notes:
1. If R<sub>TT(NOM)</sub> MR is disabled, power to the ODT receiver will be turned off to save power.
  2. If R<sub>TT(WR)</sub> is enabled, R<sub>TT(WR)</sub> will be activated by a WRITE command for a defined period time independent of the ODT pin and MR setting of R<sub>TT(Park)</sub>/R<sub>TT(NOM)</sub>. This is described in the Dynamic ODT section.
  3. When a READ command is executed, the DRAM termination state will be High-Z for a defined period independent of the ODT pin and MR setting of R<sub>TT(Park)</sub>/R<sub>TT(NOM)</sub>. This is described in the ODT During Read section.
  4. Case A is generally best for single-rank memories.
  5. Case B is generally best for dual-rank, single-slotted memories.
  6. Case C and Case D are generally best for multi-slotted memories.

### ODT Read Disable State Table

Upon receiving a READ command, the DRAM driving data disables ODT after RL - (2 or 3) clock cycles, where 2 = 1<sup>t</sup>CK preamble mode and 3 = 2<sup>t</sup>CK preamble mode. ODT stays off for a duration of BL/2 + (2 or 3) + (0 or 1) clock cycles, where 2 = 1<sup>t</sup>CK preamble mode, 3 = 2<sup>t</sup>CK preamble mode, 0 = CRC disabled, and 1 = CRC enabled.

**Table 68: Read Termination Disable Window**

Preamble	CRC	Start ODT Disable After Read	Duration of ODT Disable
1 <sup>t</sup> CK	Disabled	RL - 2	BL/2 + 2
	Enabled	RL - 2	BL/2 + 3
2 <sup>t</sup> CK	Disabled	RL - 3	BL/2 + 3
	Enabled	RL - 3	BL/2 + 4

## Synchronous ODT Mode

Synchronous ODT mode is selected whenever the DLL is turned on and locked. Based on the power-down definition, these modes include the following:

- Any bank active with CKE HIGH
- Refresh with CKE HIGH
- Idle mode with CKE HIGH
- Active power-down mode (regardless of MR1 bit A10)
- Precharge power-down mode

In synchronous ODT mode,  $R_{TT(NOM)}$  will be turned on DODTLon clock cycles after ODT is sampled HIGH by a rising clock edge and turned off DODTLoFF clock cycles after ODT is registered LOW by a rising clock edge. The ODT latency is determined by the programmed values for: CAS WRITE latency (CWL), additive latency (AL), and parity latency (PL), as well as the programmed state of the preamble.

## ODT Latency and Posted ODT

The ODT latencies for synchronous ODT mode are summarized in the table below. For details, refer to the latency definitions.

**Table 69: ODT Latency at DDR4-1600/-1866/-2133/-2400/-2666/-3200**

Applicable when write CRC is disabled

Symbol	Parameter	1 <sup>t</sup> CK Preamble	2 <sup>t</sup> CK Preamble	Unit
DODTLon	Direct ODT turn-on latency	CWL + AL + PL - 2	CWL + AL + PL - 3	tCK
DODTLoFF	Direct ODT turn-off latency	CWL + AL + PL - 2	CWL + AL + PL - 3	
RODTLoFF	READ command to internal ODT turn-off latency	CL + AL + PL - 2	CL + AL + PL - 3	
RODTLon4	READ command to $R_{TT(Park)}$ turn-on latency in BC4-fixed	RODTLoFF + 4	RODTLoFF + 5	
RODTLon8	READ command to $R_{TT(Park)}$ turn-on latency in BL8/BC4-OTF	RODTLoFF + 6	RODTLoFF + 7	
ODTH4	ODT Assertion time, BC4 mode	4	5	
ODTH8	ODT Assertion time, BL8 mode	6	7	

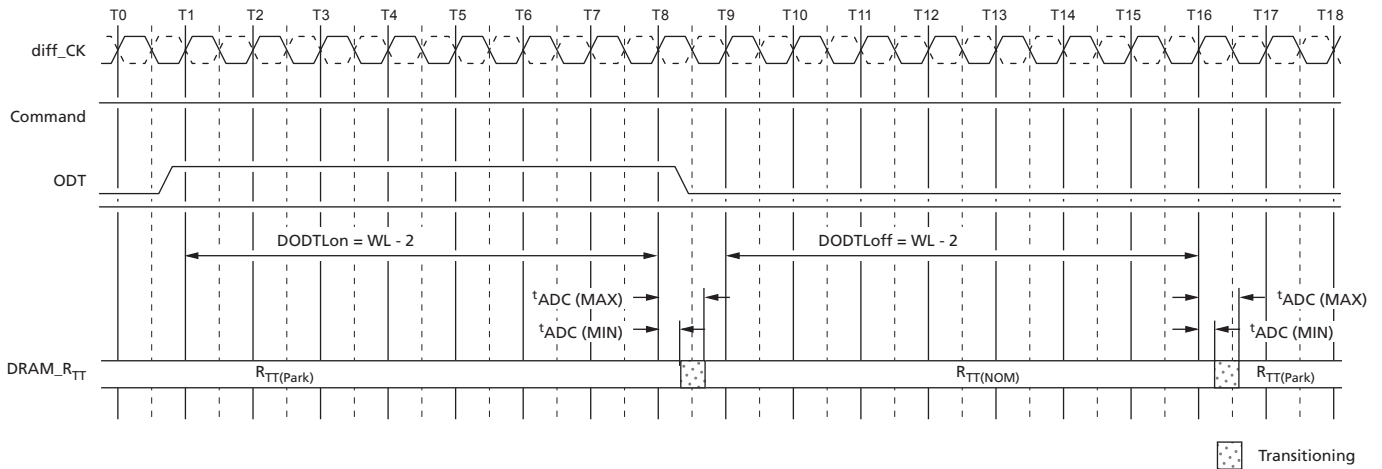
## Timing Parameters

In synchronous ODT mode, the following parameters apply:

- DODTLon, DODTLoFF, RODTLoFF, RODTLon4, RODTLon8, and <sup>t</sup>ADC (MIN)/(MAX).
- <sup>t</sup>ADC (MIN) and <sup>t</sup>ADC (MAX) are minimum and maximum  $R_{TT}$  change timing skew between different termination values. These timing parameters apply to both the synchronous ODT mode and the data termination disable mode.

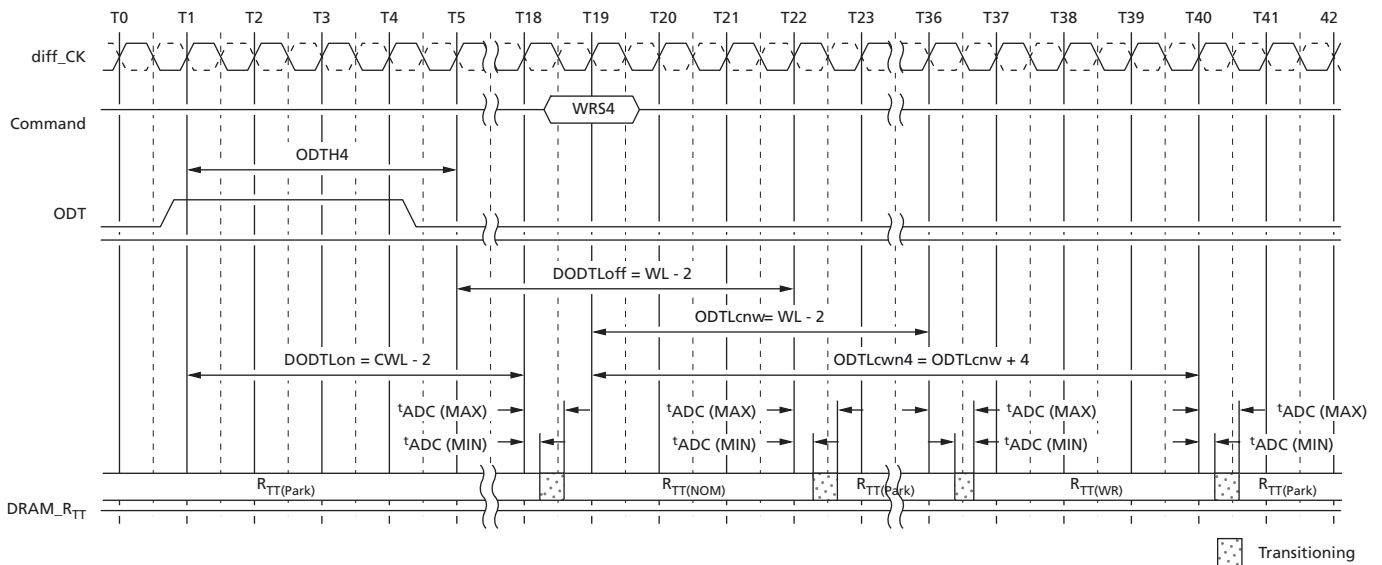
When ODT is asserted, it must remain HIGH until minimum ODTH4 (BC = 4) or ODTH8 (BL = 8) is satisfied. If write CRC mode or 2<sup>t</sup>CK preamble mode is enabled, ODTH should be adjusted to account for it. ODTH<sub>x</sub> is measured from ODT first registered HIGH to ODT first registered LOW or from the registration of a WRITE command.

Figure 193: Synchronous ODT Timing with BL8



- Notes: 1. Example for CWL = 9, AL = 0, PL = 0; DODTLon = AL + PL + CWL - 2 = 7; DODTLoFF = AL + PL + CWL - 2 = 7.  
2. ODT must be held HIGH for at least ODTH8 after assertion (T1).

Figure 194: Synchronous ODT with BC4



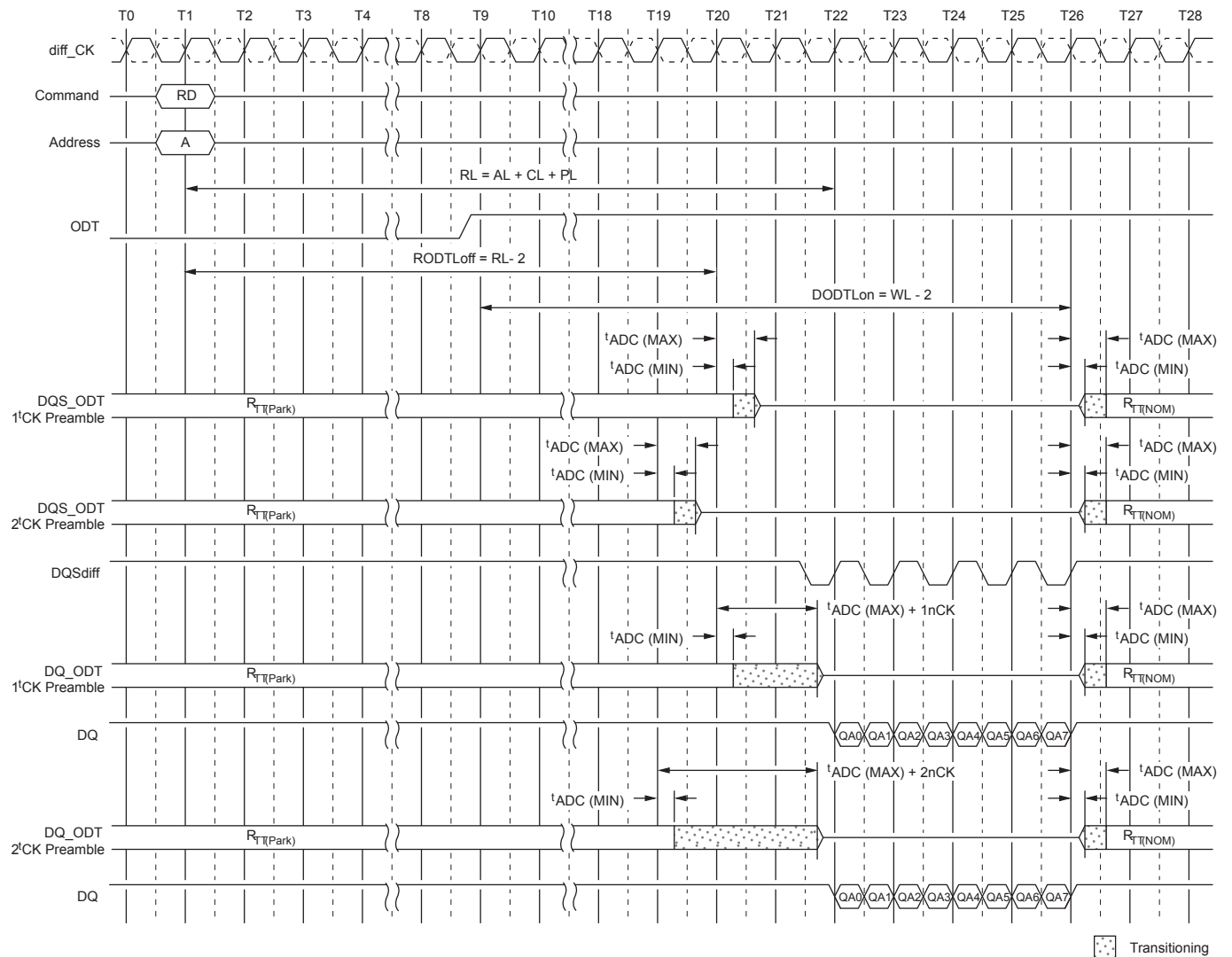
- Notes: 1. Example for CWL = 9, AL = 10, PL = 0; DODTLon/off = AL + PL + CWL - 2 = 17; ODTLcwn = AL + PL + CWL - 2 = 17.  
2. ODT must be held HIGH for at least ODTH4 after assertion (T1).

**ODT During Reads**

Because the DRAM cannot terminate with  $R_{TT}$  and drive with  $R_{ON}$  at the same time,  $R_{TT}$  may nominally not be enabled until the end of the postamble as shown in the example below. At cycle T25 the device turns on the termination when it stops driving, which is determined by  $t_{HZ}$ . If the DRAM stops driving early (that is,  $t_{HZ}$  is early), then  $t_{ADC}$  (MIN) timing may apply. If the DRAM stops driving late (that is,  $t_{HZ}$  is late), then the DRAM complies with  $t_{ADC}$  (MAX) timing.

Using  $CL = 11$  as an example for the figure below:  $PL = 0$ ,  $AL = CL - 1 = 10$ ,  $RL = PL + AL + CL = 21$ ,  $CWL = 9$ ;  $RODTL_{off} = RL - 2 = 19$ ,  $DODTL_{on} = PL + AL + CWL - 2 = 17$ ,  $1^{t}CK$  preamble.

**Figure 195: ODT During Reads**



## Dynamic ODT

In certain application cases and to further enhance signal integrity on the data bus, it is desirable that the termination strength of the device can be changed without issuing an MRS command. This requirement is supported by the dynamic ODT feature.

### Functional Description

Dynamic ODT mode is enabled if bit A9 or A10 of MR2 is set to 1.

- Three  $R_{TT}$  values are available:  $R_{TT(NOM)}$ ,  $R_{TT(WR)}$ , and  $R_{TT(Park)}$ .
  - The value for  $R_{TT(NOM)}$  is preselected via bits MR1[10:8].
  - The value for  $R_{TT(WR)}$  is preselected via bits MR2[11:9].
  - The value for  $R_{TT(Park)}$  is preselected via bits MR5[8:6].
- During operation without WRITE commands, the termination is controlled as follows:
  - Nominal termination strength  $R_{TT(NOM)}$  or  $R_{TT(Park)}$  is selected.
  - $R_{TT(NOM)}$  on/off timing is controlled via ODT pin and latencies DODTLon and DODTLoff, and  $R_{TT(Park)}$  is on when ODT is LOW.
- When a WRITE command (WR, WRA, WRS4, WRS8, WRAS4, and WRAS8) is registered, and if dynamic ODT is enabled, the termination is controlled as follows:
  - Latency ODTLcnw after the WRITE command, termination strength  $R_{TT(WR)}$  is selected.
  - Latency ODTLcwn8 (for BL8, fixed by MRS or selected OTF) or ODTLcwn4 (for BC4, fixed by MRS or selected OTF) after the WRITE command, termination strength  $R_{TT(WR)}$  is de-selected.

One or two clocks will be added into or subtracted from ODTLcwn8 and ODTLcwn4, depending on write CRC mode and/or  $2^tCK$  preamble enablement.

The following table shows latencies and timing parameters relevant to the on-die termination control in dynamic ODT mode. The dynamic ODT feature is not supported in DLL-off mode. An MRS command must be used to set  $R_{TT(WR)}$  to disable dynamic ODT externally (MR2[11:9] = 000).

**Table 70: Dynamic ODT Latencies and Timing (1<sup>t</sup>CK Preamble Mode and CRC Disabled)**

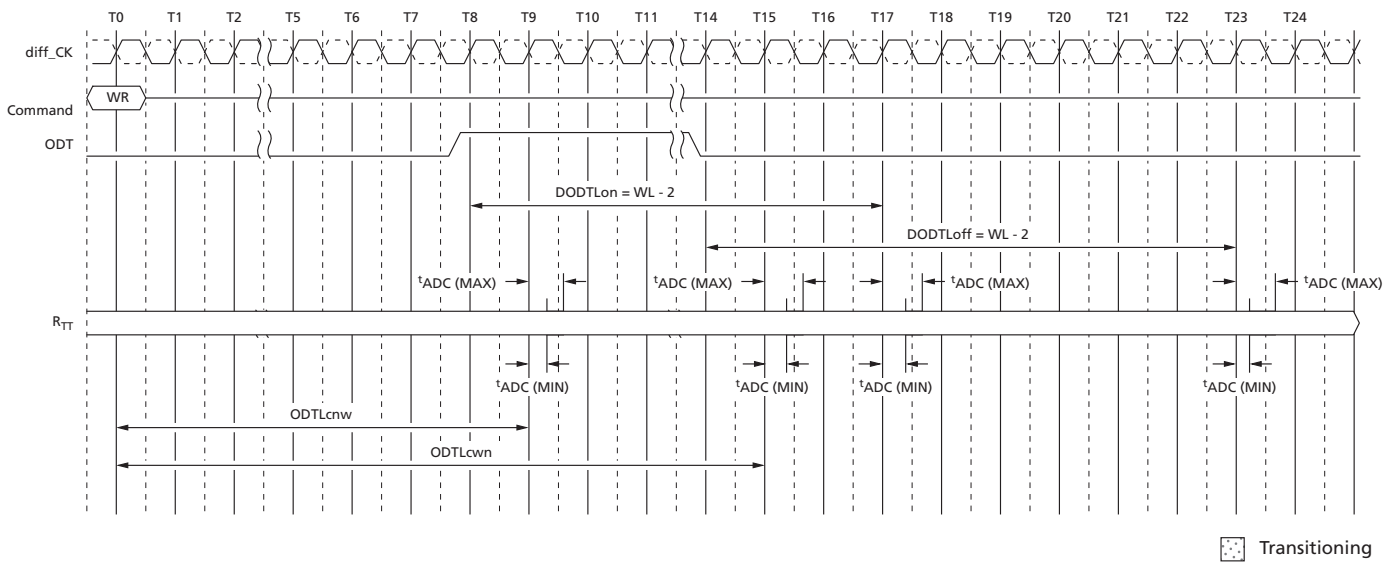
Name and Description	Abbr.	Defined from	Defined to	Definition for All DDR4 Speed Bins	Unit
ODT latency for change from $R_{TT(Park)}/R_{TT(NOM)}$ to $R_{TT(WR)}$	ODTLcnw	Registering external WRITE command	Change $R_{TT}$ strength from $R_{TT(Park)}/R_{TT(NOM)}$ to $R_{TT(WR)}$	ODTLcnw = WL - 2	<sup>t</sup> CK
ODT latency for change from $R_{TT(WR)}$ to $R_{TT(Park)}/R_{TT(NOM)}$ (BC = 4)	ODTLcwn4	Registering external WRITE command	Change $R_{TT}$ strength from $R_{TT(WR)}$ to $R_{TT(Park)}/R_{TT(NOM)}$	ODTLcwn4 = 4 + ODTLcnw	<sup>t</sup> CK
ODT latency for change from $R_{TT(WR)}$ to $R_{TT(Park)}/R_{TT(NOM)}$ (BL = 8)	ODTLcwn8	Registering external WRITE command	Change $R_{TT}$ strength from $R_{TT(NOM)}$ to $R_{TT(WR)}$	ODTLcwn8 = 6 + ODTLcnw	<sup>t</sup> CK (AVG)
$R_{TT}$ change skew	<sup>t</sup> ADC	ODTLcnw ODTLcwn	$R_{TT}$ valid	<sup>t</sup> ADC (MIN) = 0.3 <sup>t</sup> ADC (MAX) = 0.7	<sup>t</sup> CK (AVG)

**Table 71: Dynamic ODT Latencies and Timing with Preamble Mode and CRC Mode Matrix**

Symbol	1 <sup>t</sup> CK Parameter		2 <sup>t</sup> CK Parameter		Unit
	CRC Off	CRC On	CRC Off	CRC On	
ODTLcnw <sup>1</sup>	WL - 2	WL - 2	WL - 3	WL - 3	t <sup>t</sup> CK
ODTLcwn4	ODTLcnw + 4	ODTLcnw + 7	ODTLcnw + 5	ODTLcnw + 8	
ODTLcwn8	ODTLcnw + 6	ODTLcnw + 7	ODTLcnw + 7	ODTLcnw + 8	

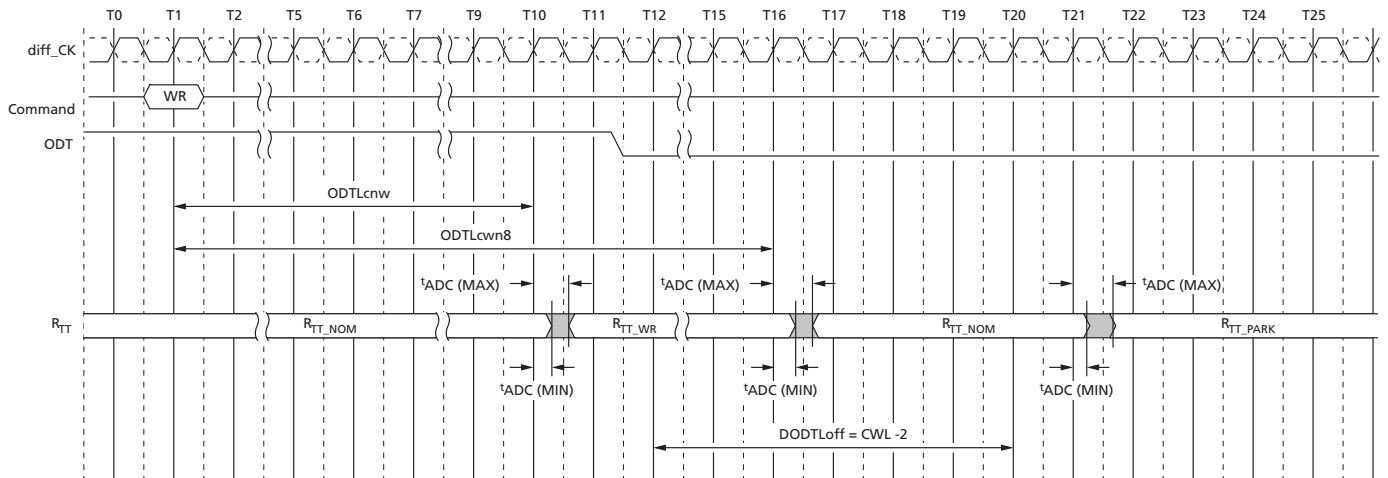
Note: 1. ODTLcnw = WL - 2 (1<sup>t</sup>CK preamble) or WL - 3 (2<sup>t</sup>CK preamble).

**Figure 196: Dynamic ODT (1<sup>t</sup> CK Preamble; CL = 14, CWL = 11, BL = 8, AL = 0, CRC Disabled)**



- Notes:
1. ODTLcnw = WL - 2 (1<sup>t</sup>CK preamble) or WL - 3 (2<sup>t</sup>CK preamble).
  2. If BC4, then ODTLcwn = WL + 4 if CRC disabled or WL + 5 if CRC enabled; If BL8, then ODTLcwn = WL + 6 if CRC disabled or WL + 7 if CRC enabled.

**Figure 197: Dynamic ODT Overlapped with  $R_{TT(NOM)}$  (CL = 14, CWL = 11, BL = 8, AL = 0, CRC Disabled)**



Note: 1. Behavior with WR command issued while ODT is registered HIGH.

## Asynchronous ODT Mode

Asynchronous ODT mode is selected when the DRAM runs in DLL-off mode. In asynchronous ODT timing mode, the internal ODT command is *not* delayed by either additive latency (AL) or the parity latency (PL) relative to the external ODT signal ( $R_{TT(NOM)}$ ). In asynchronous ODT mode, two timing parameters apply:  $t_{AONAS}$  (MIN/MAX), and  $t_{AOFAS}$  (MIN/MAX).

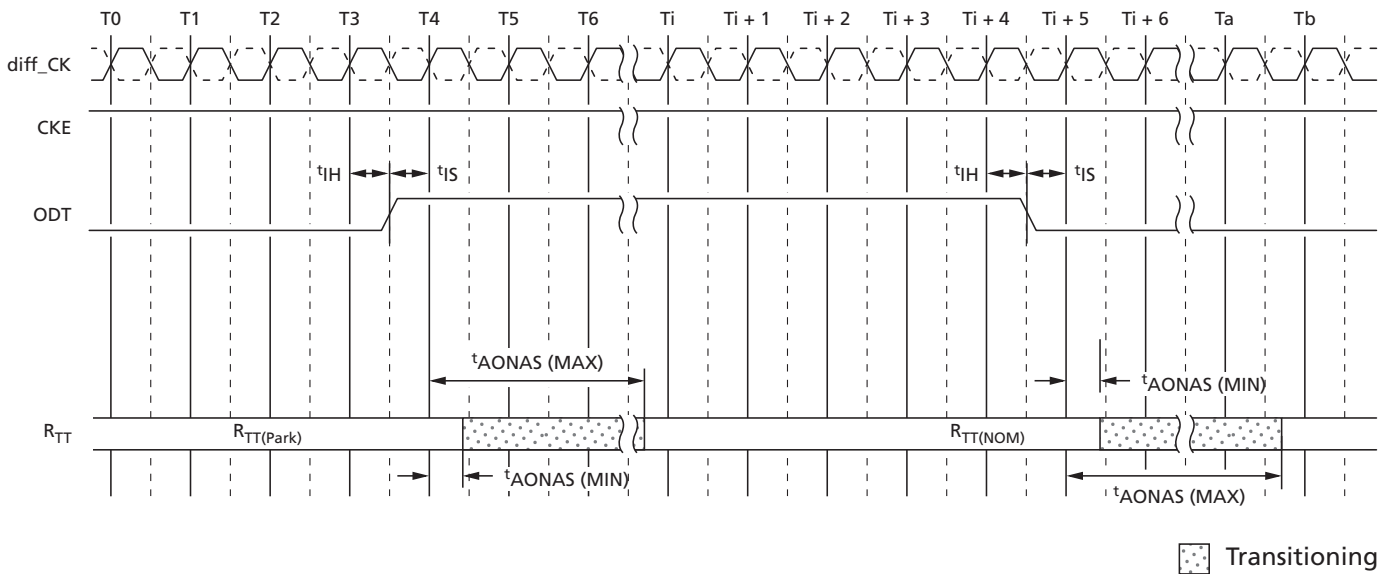
### $R_{TT(NOM)}$ Turn-on Time

- Minimum  $R_{TT(NOM)}$  turn-on time ( $t_{AONAS}$  [MIN]) is when the device termination circuit leaves  $R_{TT(Park)}$  and ODT resistance begins to turn on.
- Maximum  $R_{TT(NOM)}$  turn-on time ( $t_{AONAS}$  [MAX]) is when the ODT resistance has reached  $R_{TT(NOM)}$ .
- $t_{AONAS}$  (MIN) and  $t_{AONAS}$  (MAX) are measured from ODT being sampled HIGH.

### $R_{TT(NOM)}$ Turn-off Time

- Minimum  $R_{TT(NOM)}$  turn-off time ( $t_{AOFAS}$  [MIN]) is when the device's termination circuit starts to leave  $R_{TT(NOM)}$ .
- Maximum  $R_{TT(NOM)}$  turn-off time ( $t_{AOFAS}$  [MAX]) is when the on-die termination has reached  $R_{TT(Park)}$ .
- $t_{AOFAS}$  (MIN) and  $t_{AOFAS}$  (MAX) are measured from ODT being sampled LOW.

**Figure 198: Asynchronous ODT Timings with DLL Off**



## Electrical Specifications

### Absolute Ratings

Stresses greater than those listed may cause permanent damage to the device. This is a stress rating only, and functional operation of the device at these or any other conditions outside those indicated in the operational sections of this specification is not implied. Exposure to absolute maximum rating conditions for extended periods may adversely affect reliability. Although "unlimited" row accesses to the same row is allowed within the refresh period; excessive row accesses to the same row over a long term can result in degraded operation.

**Table 72: Absolute Maximum Ratings**

Symbol	Parameter	Min	Max	Unit	Notes
$V_{DD}$	Voltage on $V_{DD}$ pin relative to $V_{SS}$	-0.4	1.5	V	1
$V_{DDQ}$	Voltage on $V_{DDQ}$ pin relative to $V_{SS}$	-0.4	1.5	V	1
$V_{PP}$	Voltage on $V_{PP}$ pin relative to $V_{SS}$	-0.4	3.0	V	3
$V_{IN}, V_{OUT}$	Voltage on any pin relative to $V_{SS}$	-0.4	1.5	V	
$T_{STG}$	Storage temperature	-55	150	°C	2

- Notes:
- $V_{DD}$  and  $V_{DDQ}$  must be within 300mV of each other at all times, and  $V_{REF}$  must not be greater than  $0.6 \times V_{DDQ}$ . When  $V_{DD}$  and  $V_{DDQ}$  are <500mV,  $V_{REF}$  can be  $\leq 300$ mV.
  - Storage temperature is the case surface temperature on the center/top side of the DRAM. For the measurement conditions, please refer to the JESD51-2 standard.
  - $V_{PP}$  must be equal to or greater than  $V_{DD}/V_{DDQ}$  at all times when powered.

### DRAM Component Operating Temperature Range

Operating temperature,  $T_{OPER}$ , is the case surface temperature on the center/top side of the DRAM. For measurement conditions, refer to the JEDEC document JESD51-2.

**Table 73: Temperature Range**

Symbol	Parameter	Min	Max	Unit	Notes
$T_{OPER}$	Normal operating temperature range	0	85	°C	1
	Extended temperature range (optional)	>85	95	°C	2

- Notes:
- The normal temperature range specifies the temperatures at which all DRAM specifications will be supported. During operation, the DRAM case temperature must be maintained between 0°C to 85°C under all operating conditions for the commercial offering; The industrial temperature offering allows the case temperature to go below 0°C to -40°C.
  - Some applications require operation of the commercial and industrial temperature DRAMs in the extended temperature range (between 85°C and 95°C case temperature). Full specifications are supported in this range, but the following additional conditions apply:
    - REFRESH commands must be doubled in frequency, reducing the refresh interval  $t_{REFI}$  to 3.9 $\mu$ s. It is also possible to specify a component with 1X refresh ( $t_{REFI}$  to 7.8 $\mu$ s) in the extended temperature range.

- If SELF REFRESH operation is required in the extended temperature range, it is mandatory to use either the manual self refresh mode with extended temperature range capability (MR2[6] = 0 and MR2 [7] = 1) or enable the optional auto self refresh mode (MR2 [6] = 1 and MR2 [7] = 1).

## Electrical Characteristics – AC and DC Operating Conditions

### Supply Operating Conditions

**Table 74: Recommended Supply Operating Conditions**

Symbol	Parameter	Rating			Unit	Notes
		Min	Typ	Max		
V <sub>DD</sub>	Supply voltage	1.14	1.2	1.26	V	1, 2, 3, 4, 5
V <sub>DDQ</sub>	Supply voltage for output	1.14	1.2	1.26	V	1, 2, 6
V <sub>PP</sub>	Wordline supply voltage	2.375	2.5	2.750	V	7

- Notes:
1. Under all conditions V<sub>DDQ</sub> must be less than or equal to V<sub>DD</sub>.
  2. V<sub>DDQ</sub> tracks with V<sub>DD</sub>. AC parameters are measured with V<sub>DD</sub> and V<sub>DDQ</sub> tied together.
  3. V<sub>DD</sub> slew rate between 300mV and 80% of V<sub>DD,min</sub> shall be between 0.004 V/ms and 600 V/ms, 20 MHz band-limited measurement.
  4. V<sub>DD</sub> ramp time from 300mV to V<sub>DD,min</sub> shall be no longer than 200ms.
  5. A stable valid V<sub>DD</sub> level is a set DC level (0 Hz to 250 KHz) and must be no less than V<sub>DD,min</sub> and no greater than V<sub>DD,max</sub>. If the set DC level is altered anytime after initialization, the DLL reset and calibrations must be performed again after the new set DC level is final. AC noise of ±60mV (greater than 250 KHz) is allowed on V<sub>DD</sub> provided the noise doesn't alter V<sub>DD</sub> to less than V<sub>DD,min</sub> or greater than V<sub>DD,max</sub>.
  6. A stable valid V<sub>DDQ</sub> level is a set DC level (0 Hz to 250 KHz) and must be no less than V<sub>DDQ,min</sub> and no greater than V<sub>DDQ,max</sub>. If the set DC level is altered anytime after initialization, the DLL reset and calibrations must be performed again after the new set DC level is final. AC noise of ±60mV (greater than 250 KHz) is allowed on V<sub>DDQ</sub> provided the noise doesn't alter V<sub>DDQ</sub> to less than V<sub>DDQ,min</sub> or greater than V<sub>DDQ,max</sub>.
  7. A stable valid V<sub>PP</sub> level is a set DC level (0 Hz to 250 KHz) and must be no less than V<sub>PP,min</sub> and no greater than V<sub>PP,max</sub>. If the set DC level is altered anytime after initialization, the DLL reset and calibrations must be performed again after the new set DC level is final. AC noise of ±120mV (greater than 250 KHz) is allowed on V<sub>PP</sub> provided the noise doesn't alter V<sub>PP</sub> to less than V<sub>PP,min</sub> or greater than V<sub>PP,max</sub>.

**Table 75: V<sub>DD</sub> Slew Rate**

Symbol	Min	Max	Unit	Notes
V <sub>DD_sl</sub>	0.004	600	V/ms	1, 2
V <sub>DD_on</sub>	–	200	ms	3

- Notes:
1. Measurement made between 300mV and 80% V<sub>DD</sub> (minimum level).
  2. The DC bandwidth is limited to 20 MHz.
  3. Maximum time to ramp V<sub>DD</sub> from 300 mV to V<sub>DD</sub> minimum.

### Leakages

**Table 76: Leakages**

Condition	Symbol	Min	Max	Unit	Notes
Input leakage (excluding ZQ and TEN)	$I_{IN}$	-2	2	$\mu A$	1
ZQ leakage	$I_{ZQ}$	-3	3	$\mu A$	1
TEN leakage	$I_{TEN}$	-6	10	$\mu A$	1, 2
$V_{REFCA}$ leakage	$I_{VREFCA}$	-2	2	$\mu A$	3
Output leakage: $V_{OUT} = V_{DDQ}$	$I_{OZpd}$	-	5	$\mu A$	4
Output leakage: $V_{OUT} = V_{SSQ}$	$I_{OZpu}$	-50	-	$\mu A$	4, 5

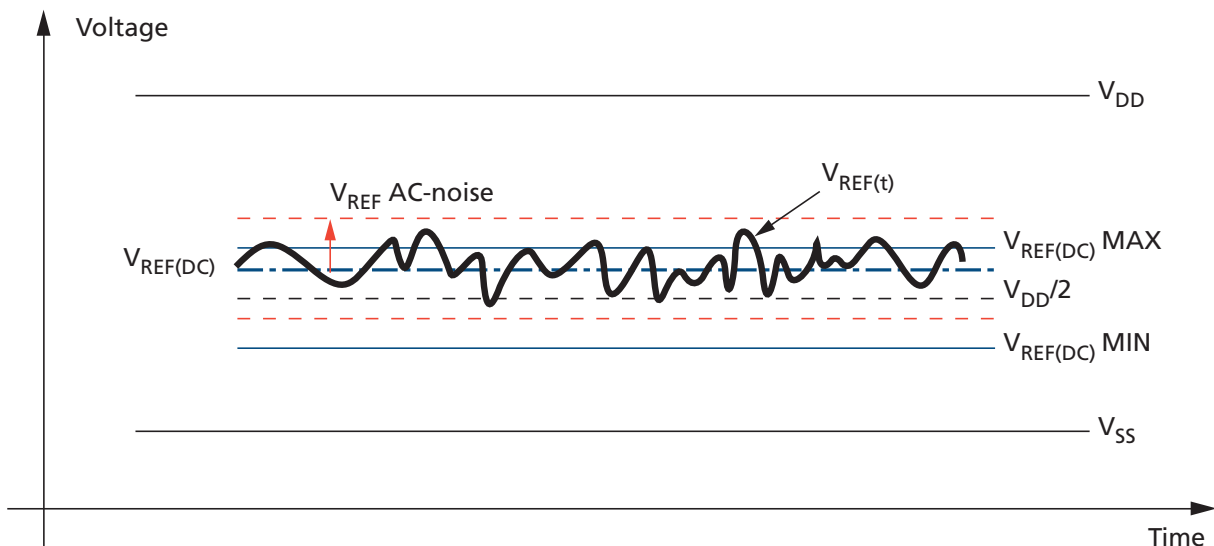
- Notes:
1. Input under test  $0V < V_{IN} < 1.1V$ .
  2. Additional leakage due to weak pull-down.
  3.  $V_{REFCA} = V_{DD}/2$ ,  $V_{DD}$  at valid level after initialization.
  4. DQs are disabled.
  5. ODT is disabled with the ODT input HIGH.

### $V_{REFCA}$ Supply

$V_{REFCA}$  is to be supplied to the DRAM and equal to  $V_{DD}/2$ . The  $V_{REFCA}$  is a reference supply input and therefore does not draw biasing current.

The DC-tolerance limits and AC-noise limits for the reference voltages  $V_{REFCA}$  are illustrated in the figure below. The figure shows a valid reference voltage  $V_{REF(t)}$  as a function of time ( $V_{REF}$  stands for  $V_{REFCA}$ ).  $V_{REF(DC)}$  is the linear average of  $V_{REF(t)}$  over a very long period of time (1 second). This average has to meet the MIN/MAX requirements. Furthermore,  $V_{REF(t)}$  may temporarily deviate from  $V_{REF(DC)}$  by no more than  $\pm 1\% V_{DD}$  for the AC-noise limit.

**Figure 199:  $V_{REFDQ}$  Voltage Range**



The voltage levels for setup and hold time measurements are dependent on  $V_{REF}$ .  $V_{REF}$  is understood as  $V_{REF(DC)}$ , as defined in the above figure. This clarifies that DC-variations of  $V_{REF}$  affect the absolute voltage a signal has to reach to achieve a valid HIGH or LOW level, and therefore, the time to which setup and hold is measured. System timing and voltage budgets need to account for  $V_{REF(DC)}$  deviations from the optimum position within the data-eye of the input signals. This also clarifies that the DRAM setup/hold specification and derating values need to include time and voltage associated with  $V_{REF}$  AC-noise. Timing and voltage effects due to AC-noise on  $V_{REF}$  up to the specified limit ( $\pm 1\%$  of  $V_{DD}$ ) are included in DRAM timings and their associated deratings.

### $V_{REFDQ}$ Supply and Calibration Ranges

The device internally generates its own  $V_{REFDQ}$ . DRAM internal  $V_{REFDQ}$  specification parameters: voltage range, step size,  $V_{REF}$  step time,  $V_{REF}$  full step time, and  $V_{REF}$  valid level are used to help provide estimated values for the internal  $V_{REFDQ}$  and are not pass/fail limits. The voltage operating range specifies the minimum required range for DDR4 SDRAM devices. The minimum range is defined by  $V_{REFDQ,min}$  and  $V_{REFDQ,max}$ . A calibration sequence should be performed by the DRAM controller to adjust  $V_{REFDQ}$  and optimize the timing and voltage margin of the DRAM data input receivers.

**Table 77:  $V_{REFDQ}$  Specification**

Parameter	Symbol	Min	Typ	Max	Unit	Notes
Range 1 $V_{REFDQ}$ operating points	$V_{REFDQ}$ R1	60%	–	92%	$V_{DDQ}$	1, 2
Range 2 $V_{REFDQ}$ operating points	$V_{REFDQ}$ R2	45%	–	77%	$V_{DDQ}$	1, 2
$V_{REF}$ step size	$V_{REF,step}$	0.5%	0.65%	0.8%	$V_{DDQ}$	3
$V_{REF}$ set tolerance	$V_{REF,set\_tol}$	–1.625%	0%	1.625%	$V_{DDQ}$	4, 5, 6
		–0.15%	0%	0.15%	$V_{DDQ}$	4, 7, 8
$V_{REF}$ step time	$V_{REF,time}$	–	–	150	ns	9, 10, 11
$V_{REF}$ valid tolerance	$V_{REF,val\_tol}$	–0.15%	0%	0.15%	$V_{DDQ}$	12

- Notes:
- $V_{REF(DC)}$  voltage is referenced to  $V_{DDQ(DC)}$ .  $V_{DDQ(DC)}$  is 1.2V.
  - DRAM range 1 or range 2 is set by the MRS6[6]6.
  - $V_{REF}$  step size increment/decrement range.  $V_{REF}$  at DC level.
  - $V_{REF,new} = V_{REF,old} \pm n \times V_{REF,step}$ ;  $n$  = number of steps. If increment, use "+," if decrement, use "-."
  - For  $n > 4$ , the minimum value of  $V_{REF}$  setting tolerance =  $V_{REF,new} - 1.625\% \times V_{DDQ}$ . The maximum value of  $V_{REF}$  setting tolerance =  $V_{REF,new} + 1.625\% \times V_{DDQ}$ .
  - Measured by recording the MIN and MAX values of the  $V_{REF}$  output over the range, drawing a straight line between those points, and comparing all other  $V_{REF}$  output settings to that line.
  - For  $n \leq 4$ , the minimum value of  $V_{REF}$  setting tolerance =  $V_{REF,new} - 0.15\% \times V_{DDQ}$ . The maximum value of  $V_{REF}$  setting tolerance =  $V_{REF,new} + 0.15\% \times V_{DDQ}$ .
  - Measured by recording the MIN and MAX values of the  $V_{REF}$  output across four consecutive steps ( $n = 4$ ), drawing a straight line between those points, and comparing all  $V_{REF}$  output settings to that line.
  - Time from MRS command to increment or decrement one step size for  $V_{REF}$ .
  - Time from MRS command to increment or decrement more than one step size up to the full range of  $V_{REF}$ .
  - If the  $V_{REF}$  monitor is enabled,  $V_{REF}$  must be derated by +10ns if DQ bus load is 0pF and an additional +15 ns/pF of DQ bus loading.
  - Only applicable for DRAM component-level test/characterization purposes. Not applicable for normal mode of operation.  $V_{REF}$  valid qualifies the step times, which will be characterized at the component level.

## $V_{REFDQ}$ Ranges

MR6[6] selects range 1 (60% to 92.5% of  $V_{DDQ}$ ) or range 2 (45% to 77.5% of  $V_{DDQ}$ ), and MR6[5:0] sets the  $V_{REFDQ}$  level, as listed in the following table. The values in MR6[6:0] will update the  $V_{DDQ}$  range and level independent of MR6[7] setting. It is recommended MR6[7] be enabled when changing the settings in MR6[6:0], and it is highly recommended MR6[7] be enabled when changing the settings in MR6[6:0] multiple times during a calibration routine.



**Table 78: V<sub>REFDQ</sub> Range and Levels**

MR6[5:0]	MR6[6] 0 = Range 1	MR6[6] 1 = Range 2	MR6[5:0]	MR6[6] 0 = Range 1	MR6[6] 1 = Range 2
00 0000	60.00%	45.00%	01 1010	76.90%	61.90%
00 0001	60.65%	45.65%	01 1011	77.55%	62.55%
00 0010	61.30%	46.30%	01 1100	78.20%	63.20%
00 0011	61.95%	46.95%	01 1101	78.85%	63.85%
00 0100	62.60%	47.60%	01 1110	79.50%	64.50%
00 0101	63.25%	48.25%	01 1111	80.15%	65.15%
00 0110	63.90%	48.90%	10 0000	80.80%	65.80%
00 0111	64.55%	49.55%	10 0001	81.45%	66.45%
00 1000	65.20%	50.20%	10 0010	82.10%	67.10%
00 1001	65.85%	50.85%	10 0011	82.75%	67.75%
00 1010	66.50%	51.50%	10 0100	83.40%	68.40%
00 1011	67.15%	52.15%	10 0101	84.05%	69.05%
00 1100	67.80%	52.80%	10 0110	84.70%	69.70%
00 1101	68.45%	53.45%	10 0111	85.35%	70.35%
00 1110	69.10%	54.10%	10 1000	86.00%	71.00%
00 1111	69.75%	54.75%	10 1001	86.65%	71.65%
01 0000	70.40%	55.40%	10 1010	87.30%	72.30%
01 0001	71.05%	56.05%	10 1011	87.95%	72.95%
01 0010	71.70%	56.70%	10 1100	88.60%	73.60%
01 0011	72.35%	57.35%	10 1101	89.25%	74.25%
01 0100	73.00%	58.00%	10 1110	89.90%	74.90%
01 0101	73.65%	58.65%	10 1111	90.55%	75.55%
01 0110	74.30%	59.30%	11 0000	91.20%	76.20%
01 0111	74.95%	59.95%	11 0001	91.85%	76.85%
01 1000	75.60%	60.60%	11 0010	92.50%	77.50%
01 1001	76.25%	61.25%	11 0011 to 11 1111 are reserved		

## Electrical Characteristics – AC and DC Single-Ended Input Measurement Levels

### RESET<sub>n</sub> Input Levels

**Table 79: RESET<sub>n</sub> Input Levels (CMOS)**

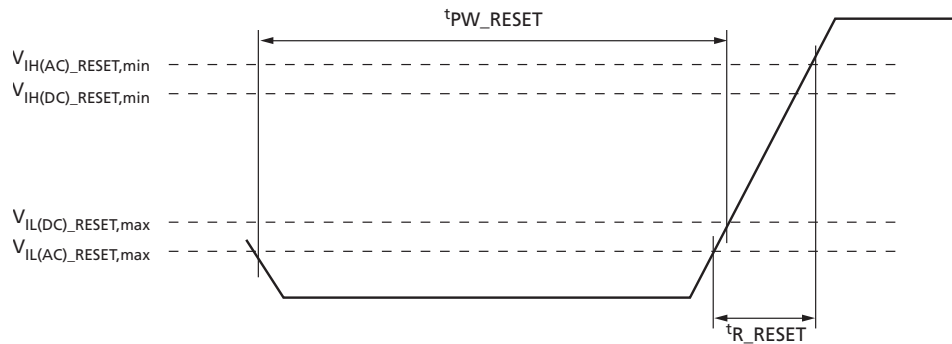
Parameter	Symbol	Min	Max	Unit	Note
AC input high voltage	V <sub>IH(AC)_RESET</sub>	0.8 × V <sub>DD</sub>	V <sub>DD</sub>	V	1
DC input high voltage	V <sub>IH(DC)_RESET</sub>	0.7 × V <sub>DD</sub>	V <sub>DD</sub>	V	2
DC input low voltage	V <sub>IL(DC)_RESET</sub>	V <sub>SS</sub>	0.3 × V <sub>DD</sub>	V	3

**Table 79: RESET\_n Input Levels (CMOS) (Continued)**

Parameter	Symbol	Min	Max	Unit	Note
AC input low voltage	$V_{IL(AC\_RESET)}$	$V_{SS}$	$0.2 \times V_{DD}$	V	4
Rising time	$t^R_{RESET}$	–	1	$\mu s$	5
RESET pulse width after power-up	$t^{PW}_{RESET\_S}$	1	–	$\mu s$	6, 7
RESET pulse width during power-up	$t^{PW}_{RESET\_L}$	200	–	$\mu s$	6

- Notes:
- Overshoot should not exceed the  $V_{IN}$  shown in the Absolute Maximum Ratings table.
  - After RESET\_n is registered HIGH, the RESET\_n level must be maintained above  $V_{IH(DC\_RESET)}$ , otherwise operation will be uncertain until it is reset by asserting RESET\_n signal LOW.
  - After RESET\_n is registered LOW, the RESET\_n level must be maintained below  $V_{IL(DC\_RESET)}$  during  $t^{PW}_{RESET}$ , otherwise the DRAM may not be reset.
  - Undershoot should not exceed the  $V_{IN}$  shown in the Absolute Maximum Ratings table.
  - Slope reversal (ring-back) during this level transition from LOW to HIGH should be mitigated as much as possible.
  - RESET is destructive to data contents.
  - See RESET Procedure at Power Stable Condition figure.

**Figure 200: RESET\_n Input Slew Rate Definition**



## Command/Address Input Levels

**Table 80: Command and Address Input Levels: DDR4-1600 Through DDR4-2400**

Parameter	Symbol	Min	Max	Unit	Note
AC input high voltage	$V_{IH(AC)}$	$V_{REF} + 100$	$V_{DD5}$	mV	1, 2, 3
DC input high voltage	$V_{IH(DC)}$	$V_{REF} + 75$	$V_{DD}$	mV	1, 2
DC input low voltage	$V_{IL(DC)}$	$V_{SS}$	$V_{REF} - 75$	mV	1, 2
AC input low voltage	$V_{IL(AC)}$	$V_{SS5}$	$V_{REF} - 100$	mV	1, 2, 3
Reference voltage for CMD/ADDR inputs	$V_{REFCA(DC)}$	$0.49 \times V_{DD}$	$0.51 \times V_{DD}$	V	4

- Notes:
- For input except RESET\_n.  $V_{REF} = V_{REFCA(DC)}$ .
  - $V_{REF} = V_{REFCA(DC)}$ .
  - Input signal must meet  $V_{IL}/V_{IH(AC)}$  to meet  $t^IS$  timings and  $V_{IL}/V_{IH(DC)}$  to meet  $t^IH$  timings.
  - The AC peak noise on  $V_{REF}$  may not allow  $V_{REF}$  to deviate from  $V_{REFCA(DC)}$  by more than  $\pm 1\% V_{DD}$  (for reference: approximately  $\pm 12mV$ ).

5. Refer to “Overshoot and Undershoot Specifications.”

**Table 81: Command and Address Input Levels: DDR4-2666**

Parameter	Symbol	Min	Max	Unit	Note
AC input high voltage	$V_{IH(AC)}$	$V_{REF} + 90$	$V_{DD5}$	mV	1, 2, 3
DC input high voltage	$V_{IH(DC)}$	$V_{REF} + 65$	$V_{DD}$	mV	1, 2
DC input low voltage	$V_{IL(DC)}$	$V_{SS}$	$V_{REF} - 65$	mV	1, 2
AC input low voltage	$V_{IL(AC)}$	$V_{SS5}$	$V_{REF} - 90$	mV	1, 2, 3
Reference voltage for CMD/ADDR inputs	$V_{REFCA(DC)}$	$0.49 \times V_{DD}$	$0.49 \times V_{DD}$	V	4

- Notes:
1. For input except RESET\_n.  $V_{REF} = V_{REFCA(DC)}$ .
  2.  $V_{REF} = V_{REFCA(DC)}$ .
  3. Input signal must meet  $V_{IL}/V_{IH(AC)}$  to meet  $t_{IS}$  timings and  $V_{IL}/V_{IH(DC)}$  to meet  $t_{IH}$  timings.
  4. The AC peak noise on  $V_{REF}$  may not allow  $V_{REF}$  to deviate from  $V_{REFCA(DC)}$  by more than  $\pm 1\% V_{DD}$  (for reference: approximately  $\pm 12mV$ ).
  5. Refer to “Overshoot and Undershoot Specifications.”

**Table 82: Command and Address Input Levels: DDR4-2933 and DDR4-3200**

Parameter	Symbol	Min	Max	Unit	Note
AC input high voltage	$V_{IH(AC)}$	$V_{REF} + 90$	$V_{DD5}$	mV	1, 2, 3
DC input high voltage	$V_{IH(DC)}$	$V_{REF} + 65$	$V_{DD}$	mV	1, 2
DC input low voltage	$V_{IL(DC)}$	$V_{SS}$	$V_{REF} - 65$	mV	1, 2
AC input low voltage	$V_{IL(AC)}$	$V_{SS5}$	$V_{REF} - 90$	mV	1, 2, 3
Reference voltage for CMD/ADDR inputs	$V_{REFCA(DC)}$	$0.49 \times V_{DD}$	$0.49 \times V_{DD}$	V	4

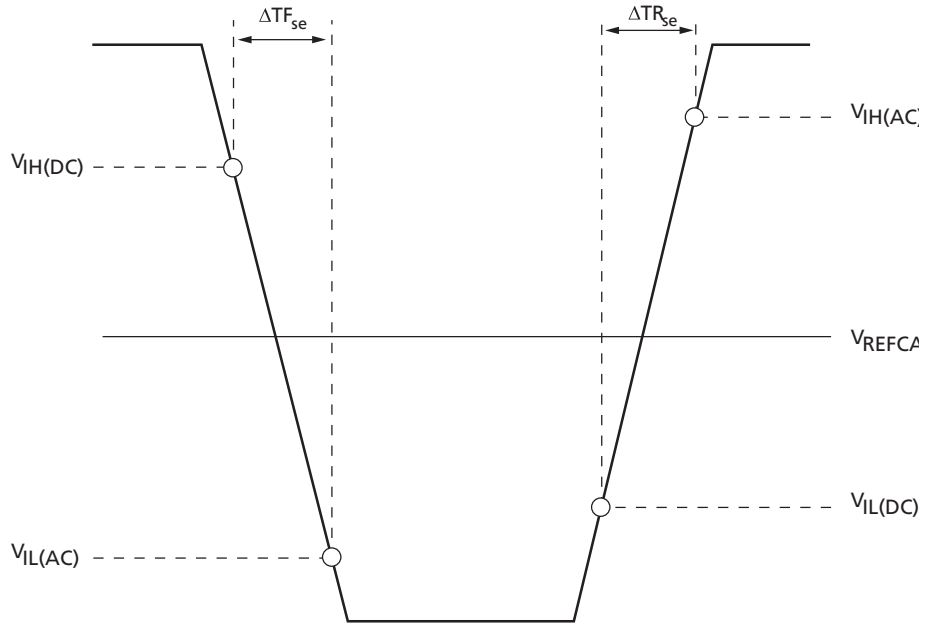
- Notes:
1. For input except RESET\_n.  $V_{REF} = V_{REFCA(DC)}$ .
  2.  $V_{REF} = V_{REFCA(DC)}$ .
  3. Input signal must meet  $V_{IL}/V_{IH(AC)}$  to meet  $t_{IS}$  timings and  $V_{IL}/V_{IH(DC)}$  to meet  $t_{IH}$  timings.
  4. The AC peak noise on  $V_{REF}$  may not allow  $V_{REF}$  to deviate from  $V_{REFCA(DC)}$  by more than  $\pm 1\% V_{DD}$  (for reference: approximately  $\pm 12mV$ ).
  5. Refer to “Overshoot and Undershoot Specifications.”

**Table 83: Single-Ended Input Slew Rates**

Parameter	Symbol	Min	Max	Unit	Note
Single-ended input slew rate – CA	$SR_{CA}$	1.0	7.0	V/ns	1, 2, 3, 4

- Notes:
1. For input except RESET\_n.
  2.  $V_{REF} = V_{REFCA(DC)}$ .
  3.  $t_{IS}/t_{IH}$  timings assume  $SR_{CA} = 1V/ns$ .
  4. Measured between  $V_{IH(AC)}$  and  $V_{IL(AC)}$  for falling edges and between  $V_{IL(AC)}$  and  $V_{IH(AC)}$  for rising edges

**Figure 201: Single-Ended Input Slew Rate Definition**



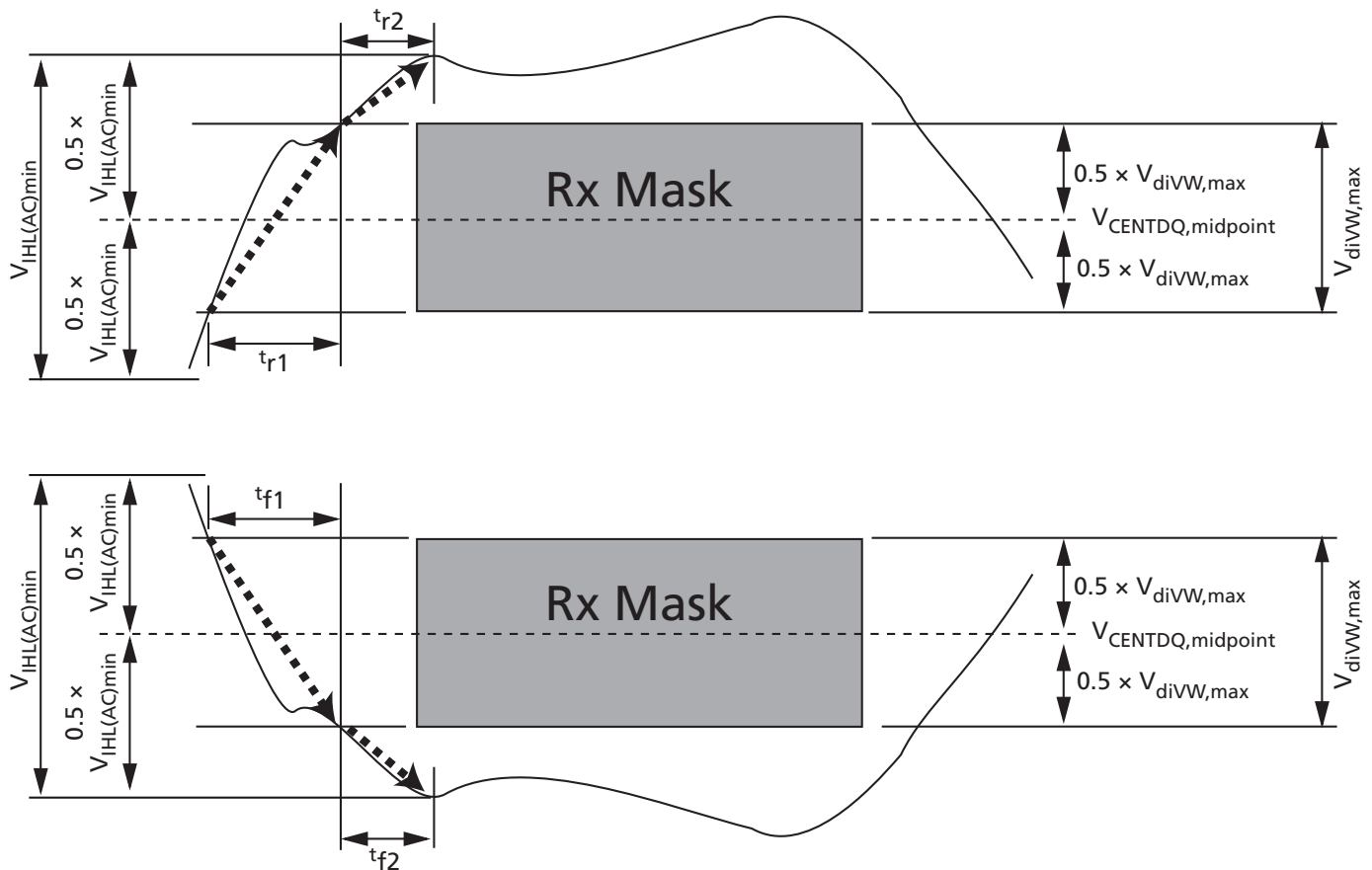
### Data Receiver Input Requirements

The following parameters apply to the data receiver Rx MASK operation detailed in the Write Timing section, Data Strobe-to-Data Relationship.

The rising edge slew rates are defined by  $srr1$  and  $srr2$ . The slew rate measurement points for a rising edge are shown in the figure below. A LOW-to-HIGH transition time,  $t_{r1}$ , is measured from  $0.5 \times V_{diVW,max}$  below  $V_{CENTDQ,midpoint}$  to the last transition through  $0.5 \times V_{diVW,max}$  above  $V_{CENTDQ,midpoint}$ ;  $t_{r2}$  is measured from the last transition through  $0.5 \times V_{diVW,max}$  above  $V_{CENTDQ,midpoint}$  to the first transition through the  $0.5 \times V_{IHL(AC)min}$  above  $V_{CENTDQ,midpoint}$ .

The falling edge slew rates are defined by  $srf1$  and  $srf2$ . The slew rate measurement points for a falling edge are shown in the figure below. A HIGH-to-LOW transition time,  $t_{f1}$ , is measured from  $0.5 \times V_{diVW,max}$  above  $V_{CENTDQ,midpoint}$  to the last transition through  $0.5 \times V_{diVW,max}$  below  $V_{CENTDQ,midpoint}$ ;  $t_{f2}$  is measured from the last transition through  $0.5 \times V_{diVW,max}$  below  $V_{CENTDQ,midpoint}$  to the first transition through the  $0.5 \times V_{IHL(AC)min}$  below  $V_{CENTDQ,midpoint}$ .

Figure 202: DQ Slew Rate Definitions



- Notes:
1. Rising edge slew rate equation  $srr1 = V_{diVW,max} / (t_{r1})$ .
  2. Rising edge slew rate equation  $srr2 = (V_{IHL(AC)min} - V_{diVW,max}) / (2 \times t_{r2})$ .
  3. Falling edge slew rate equation  $srf1 = V_{diVW,max} / (t_{f1})$ .

4. Falling edge slew rate equation  $srf2 = (V_{IHL(AC)min} - V_{diVW,max}) / (2 \times t_{f2})$ .

**Table 84: DQ Input Receiver Specifications**

Note 1 applies to the entire table

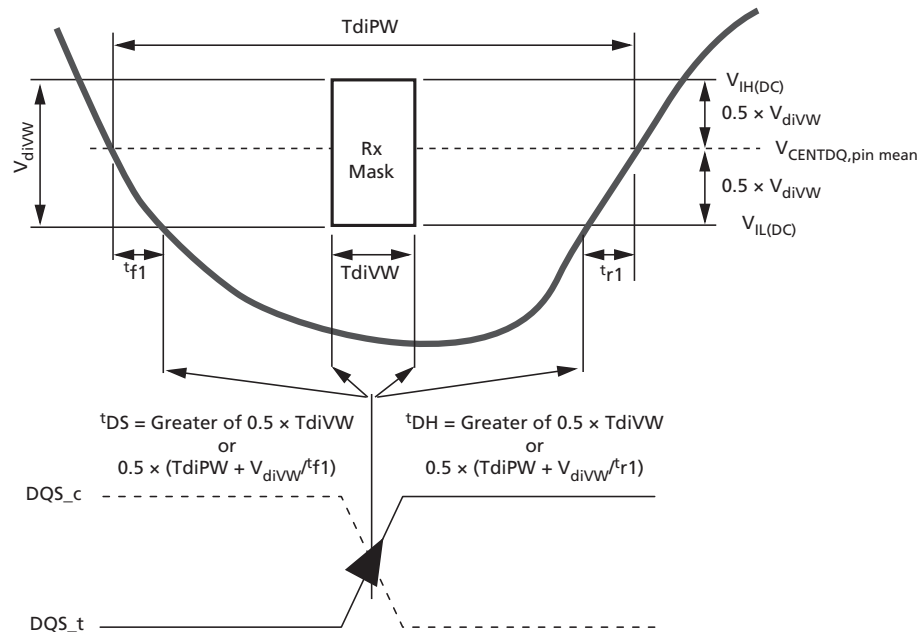
Parameter	Symbol	DDR4-1600, 1866, 2133		DDR4-2400		DDR4-2666		DDR4-2933		DDR4-3200		Unit	Notes
		Min	Max	Min	Max	Min	Max	Min	Max	Min	Max		
V <sub>IN</sub> Rx mask input peak-to-peak	V <sub>diVW</sub>	–	136	–	130	–	120	–	115	–	110	mV	2, 3
DQ Rx input timing window	TdiVW	–	0.2	–	0.2	–	0.22	–	0.23	–	0.23	UI	2, 3
DQ AC input swing peak-to-peak	V <sub>IHL(AC)</sub>	186	–	160	–	150	–	145	–	140	–	mV	4, 5
DQ input pulse width	TdiPW	0.58	–	0.58	–	0.58	–	0.58	–	0.58	–	UI	6
DQS-to-DQ Rx mask offset	<sup>t</sup> DQS2D Q	–0.17	0.17	–0.17	0.17	–0.19	0.19	–0.22	0.22	–0.22	0.22	UI	7
DQ-to-DQ Rx mask offset	<sup>t</sup> DQ2DQ	–	0.1	–	0.1	–	0.105	–	0.115	–	0.125	UI	8
Input slew rate over V <sub>diVW</sub> if <sup>t</sup> CK ≥ 0.925ns	srr1, srf1	1	9	1	9	1	9	1	9	1	9	V/ns	9
Input slew rate over V <sub>diVW</sub> if 0.935ns > <sup>t</sup> CK ≥ 0.625ns	srr1, srf1	–	–	1.25	9	1.25	9	1.25	9	1.25	9	V/ns	9
Rising input slew rate over 1/2 V <sub>IHL(AC)</sub>	srr2	0.2 × srr1	9	0.2 × srr1	9	0.2 × srr1	9	0.2 × srr1	9	0.2 × srr1	9	V/ns	10
Falling input slew rate over 1/2 V <sub>IHL(AC)</sub>	srf2	0.2 × srf1	9	0.2 × srf1	9	0.2 × srf1	9	0.2 × srf1	9	0.2 × srf1	9	V/ns	10

- Notes:
- All Rx mask specifications must be satisfied for each UI. For example, if the minimum input pulse width is violated when satisfying TdiVW (MIN), V<sub>diVW,max</sub>, and minimum slew rate limits, then either TdiVW (MIN) or minimum slew rates would have to be increased to the point where the minimum input pulse width would no longer be violated.
  - Data Rx mask voltage and timing total input valid window where V<sub>diVW</sub> is centered around V<sub>CENTDQ,midpoint</sub> after V<sub>REFDQ</sub> training is completed. The data Rx mask is applied per bit and should include voltage and temperature drift terms. The input buffer design specification is to achieve at least a BER = 1<sup>e-16</sup> when the Rx mask is not violated.
  - Defined over the DQ internal V<sub>REF</sub> range 1.
  - Overshoot and undershoot specifications apply.
  - DQ input pulse signal swing into the receiver must meet or exceed V<sub>IHL(AC)min</sub>. V<sub>IHL(AC)min</sub> is to be achieved on an UI basis when a rising and falling edge occur in the same UI (a valid TdiPW).
  - DQ minimum input pulse width defined at the V<sub>CENTDQ,midpoint</sub>.

7. DQS-to-DQ Rx mask offset is skew between DQS and DQ within a nibble (x4) or word (x8, x16 [for x16, the upper and lower bytes are treated as separate x8s]) at the SDRAM balls over process, voltage, and temperature.
8. DQ-to-DQ Rx mask offset is skew between DQs within a nibble (x4) or word (x8, x16) at the SDRAM balls for a given component over process, voltage, and temperature.
9. Input slew rate over  $V_{diVW}$  mask centered at  $V_{CENTDQ, midpoint}$ . Slowest DQ slew rate to fastest DQ slew rate per transition edge must be within 1.7V/ns of each other.
10. Input slew rate between  $V_{diVW}$  mask edge and  $V_{IHL(AC)min}$  points.

The following figure shows the Rx mask relationship to the input timing specifications relative to system  $t^{\prime}DS$  and  $t^{\prime}DH$ . The classical definition for  $t^{\prime}DS/t^{\prime}DH$  required a DQ rising and falling edges to not violate  $t^{\prime}DS$  and  $t^{\prime}DH$  relative to the DQS strobe at any time; however, with the Rx mask  $t^{\prime}DS$  and  $t^{\prime}DH$  can shift relative to the DQS strobe provided the input pulse width specification is satisfied and the Rx mask is not violated.

**Figure 203: Rx Mask Relative to  $t^{\prime}DS/t^{\prime}DH$**



The following figure and table show an example of the worst case Rx mask required if the DQS and DQ pins do not have DRAM controller to DRAM write DQ training. The figure and table show that without DRAM write DQ training, the Rx mask would increase from 0.2UI to essentially 0.54UI. This would also be the minimum  $t^{\prime}DS$  and  $t^{\prime}DH$  required as well.

Figure 204: Rx Mask Without Write Training

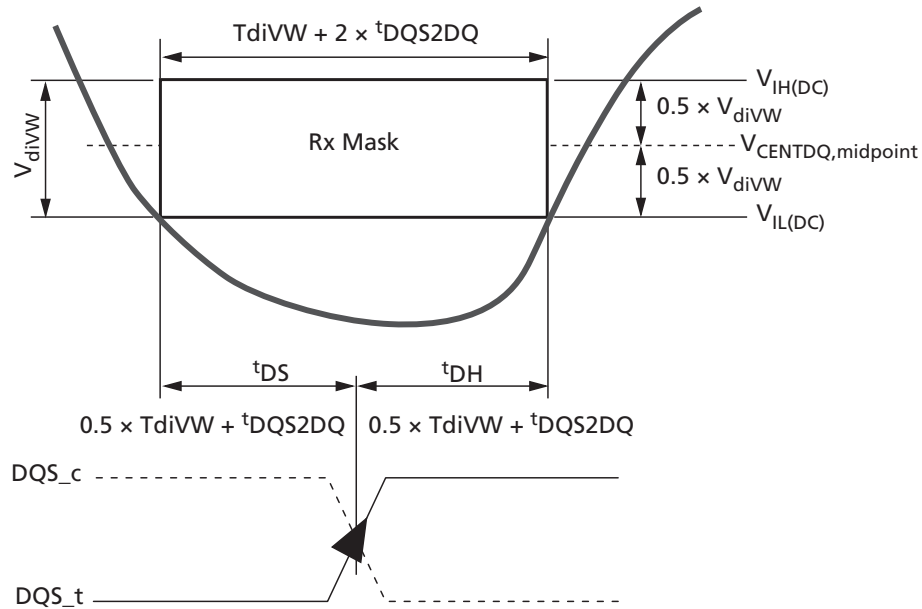


Table 85: Rx Mask and  $t_{DS}/t_{DH}$  Without Write Training

DDR4	$V_{IHL(AC)}$ (mV)	$T_{diPW}$ (UI)	$V_{diVW}$ (mV)	$T_{diVW}$ (UI)	$t_{DQS2DQ}$ (UI)	$t_{DQ2DQ}$ (UI)	Rx Mask (ps)	$t_{DS}/t_{DH}$ No Training (ps)
1600	186	0.58	136	0.2	$\pm 0.17$	0.1	125	338
1866	186	0.58	136	0.2	$\pm 0.17$	0.1	107.1	289
2133	186	0.58	136	0.2	$\pm 0.17$	0.1	3.84	253
2400	160	0.58	130	0.2	$\pm 0.17$	0.1	83.3	225
2666	150	0.58	120	0.22	$\pm 0.19$	0.105	82.5	225
2933	145	0.58	115	0.23	$\pm 0.22$	0.115	78.4	228
3200	140	0.58	110	0.23	$\pm 0.22$	0.125	71.8	209

Note: 1.  $V_{IHL(AC)}$ ,  $V_{diVW}$ , and  $V_{ILH(DC)}$  referenced to  $V_{CENTDQ,midpoint}$ .

## Connectivity Test (CT) Mode Input Levels

Table 86: TEN Input Levels (CMOS)

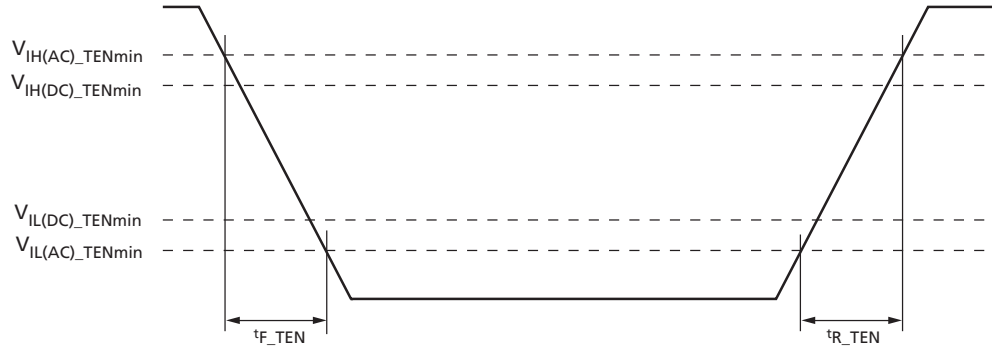
Parameter	Symbol	Min	Max	Unit	Note
TEN AC input high voltage	$V_{IH(AC)_TEN}$	$0.8 \times V_{DD}$	$V_{DD}$	V	1
TEN DC input high voltage	$V_{IH(DC)_TEN}$	$0.7 \times V_{DD}$	$V_{DD}$	V	
TEN DC input low voltage	$V_{IL(DC)_TEN}$	$V_{SS}$	$0.3 \times V_{DD}$	V	
TEN AC input low voltage	$V_{IL(AC)_TEN}$	$V_{SS}$	$0.2 \times V_{DD}$	V	2
TEN falling time	$t_{F\_TEN}$	–	10	ns	

**Table 86: TEN Input Levels (CMOS) (Continued)**

Parameter	Symbol	Min	Max	Unit	Note
TEN rising time	$t_{R\_TEN}$	–	10	ns	

- Notes: 1. Overshoot should not exceed the  $V_{IN}$  values in the Absolute Maximum Ratings table.  
 2. Undershoot should not exceed the  $V_{IN}$  values in the Absolute Maximum Ratings table.

**Figure 205: TEN Input Slew Rate Definition**

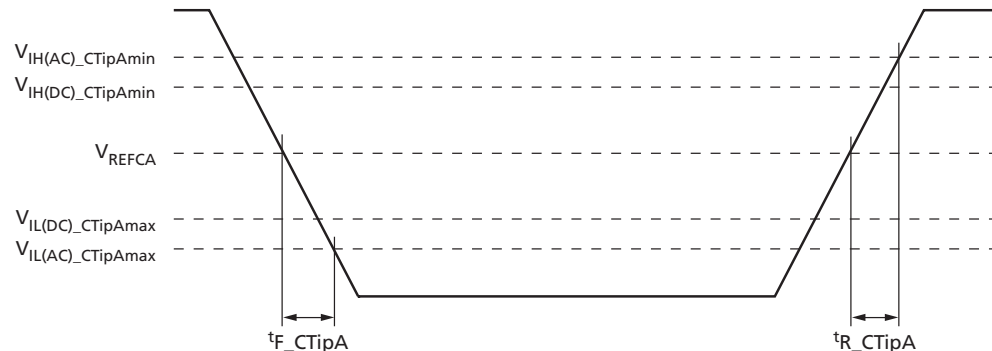


**Table 87: CT Type-A Input Levels**

Parameter	Symbol	Min	Max	Unit	Note
CTipA AC input high voltage	$V_{IH(AC)}$	$V_{REF} + 200$	$V_{DD1}^1$	V	2, 3
CTipA DC input high voltage	$V_{IH(DC)}$	$V_{REF} + 150$	$V_{DD}$	V	2, 3
CTipA DC input low voltage	$V_{IL(DC)}$	$V_{SS}$	$V_{REF} - 150$	V	2, 3
CTipA AC input low voltage	$V_{IL(AC)}$	$V_{SS1}^1$	$V_{REF} - 200$	V	2, 3
CTipA falling time	$t_{F\_CTipA}$	–	5	ns	2
CTipA rising time	$t_{R\_CTipA}$	–	5	ns	2

- Notes: 1. Refer to Overshoot and Undershoot Specifications.  
 2. CT Type-A inputs: CS<sub>n</sub>, BG[1:0], BA[1:0], A[9:0], A10/AP, A11, A12/BC<sub>n</sub>, A13, WE<sub>n</sub>/A14, CAS<sub>n</sub>/A15, RAS<sub>n</sub>/A16, CKE, ACT<sub>n</sub>, ODT, CLK<sub>t</sub>, CLK<sub>C</sub>, PAR.  
 3.  $V_{REFCA} = 0.5 \times V_{DD}$ .

**Figure 206: CT Type-A Input Slew Rate Definition**

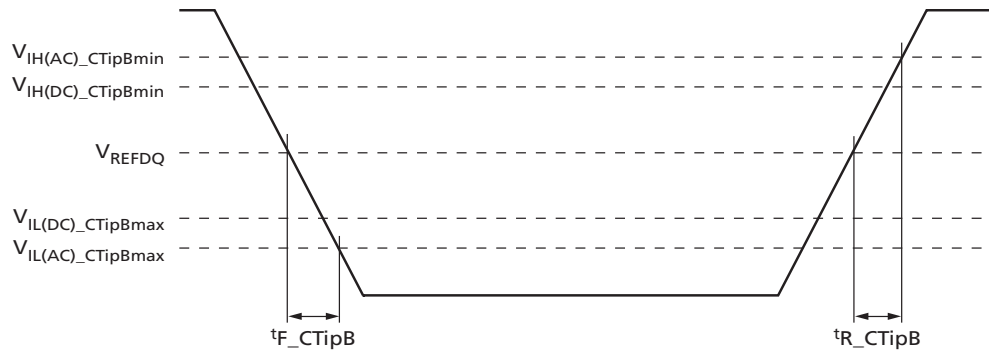


**Table 88: CT Type-B Input Levels**

Parameter	Symbol	Min	Max	Unit	Note
CTipB AC input high voltage	$V_{IH(AC)}$	$V_{REF} + 300$	$V_{DD1}^1$	V	2, 3
CTipB DC input high voltage	$V_{IH(DC)}$	$V_{REF} + 200$	$V_{DD}$	V	2, 3
CTipB DC input low voltage	$V_{IL(DC)}$	$V_{SS}$	$V_{REF} - 200$	V	2, 3
CTipB AC input low voltage	$V_{IL(AC)}$	$V_{SS1}^1$	$V_{REF} - 300$	V	2, 3
CTipB falling time	$t^*_F\_CTipB$	–	5	ns	2
CTipB rising time	$t^*_R\_CTipB$	–	5	ns	2

- Notes: 1. Refer to Overshoot and Undershoot Specifications.  
2. CT Type-B inputs: DML\_n/DBIL\_n, DMU\_n/DBIU\_n and DM\_n/DBI\_n.  
3.  $V_{REFDQ}$  should be  $0.5 \times V_{DD}$

**Figure 207: CT Type-B Input Slew Rate Definition**

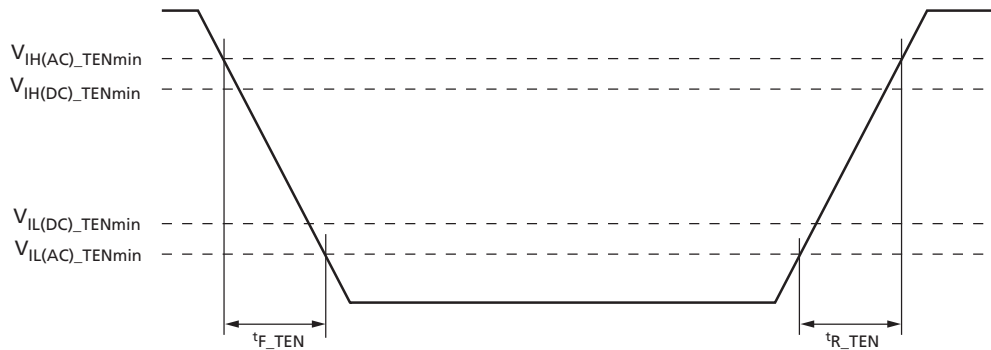


**Table 89: CT Type-C Input Levels (CMOS)**

Parameter	Symbol	Min	Max	Unit	Note
CTipC AC input high voltage	$V_{IH(AC)\_CTipC}$	$0.8 \times V_{DD}$	$V_{DD}^1$	V	2
CTipC DC input high voltage	$V_{IH(DC)\_CTipC}$	$0.7 \times V_{DD}$	$V_{DD}$	V	2
CTipC DC input low voltage	$V_{IL(DC)\_CTipC}$	$V_{SS}$	$0.3 \times V_{DD}$	V	2
CTipC AC input low voltage	$V_{IL(AC)\_CTipC}$	$V_{SS}^1$	$0.2 \times V_{DD}$	V	2
CTipC falling time	$t^*_F\_CTipC$	–	10	ns	2
CTipC rising time	$t^*_R\_CTipC$	–	10	ns	2

- Notes: 1. Refer to Overshoot and Undershoot Specifications.  
2. CT Type-C inputs: Alert\_n.

**Figure 208: CT Type-C Input Slew Rate Definition**

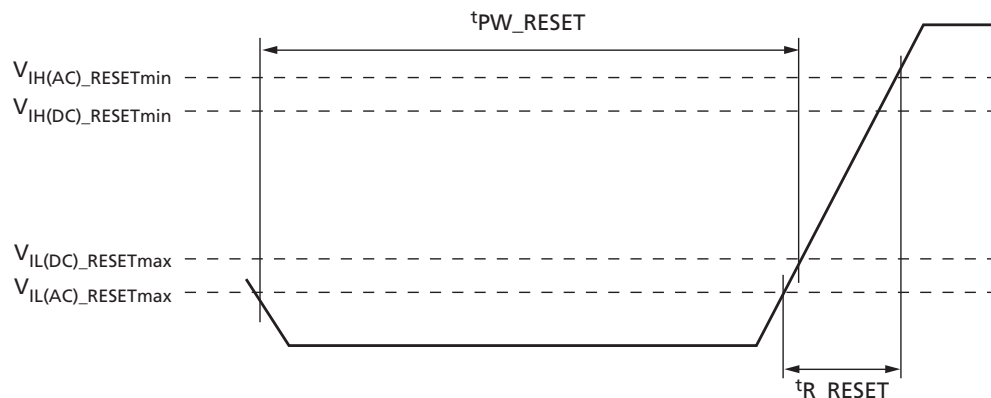


**Table 90: CT Type-D Input Levels**

Parameter	Symbol	Min	Max	Unit	Note
CTipD AC input high voltage	$V_{IH(AC\_CTipD)}$	$0.8 \times V_{DD}$	$V_{DD}$	V	4
CTipD DC input high voltage	$V_{IH(DC\_CTipD)}$	$0.7 \times V_{DD}$	$V_{DD}$	V	2
CTipD DC input low voltage	$V_{IL(DC\_CTipD)}$	$V_{SS}$	$0.3 \times V_{DD}$	V	1
CTipD AC input low voltage	$V_{IL(AC\_CTipD)}$	$V_{SS}$	$0.2 \times V_{DD}$	V	5
Rising time	$t^R_{RESET}$	–	1	$\mu s$	3
RESET pulse width - after power-up	$t^{PW}_{RESET\_S}$	1	–	$\mu s$	
RESET pulse width - during power-up	$t^{PW}_{RESET\_L}$	200	–	$\mu s$	

- Notes:
1. After RESET\_n is registered LOW, the RESET\_n level must be maintained below  $V_{IL(DC\_RESET)}$  during  $t^{PW}_{RESET}$ , otherwise, the DRAM may not be reset.
  2. After RESET\_n is registered HIGH, the RESET\_n level must be maintained above  $V_{IH(DC\_RESET)}$ , otherwise, operation will be uncertain until it is reset by asserting RESET\_n signal LOW.
  3. Slope reversal (ring-back) during this level transition from LOW to HIGH should be mitigated as much as possible.
  4. Overshoot should not exceed the  $V_{IN}$  values in the Absolute Maximum Ratings table.
  5. Undershoot should not exceed the  $V_{IN}$  values in the Absolute Maximum Ratings table.
  6. CT Type-D inputs: RESET\_n; same requirements as in normal mode.

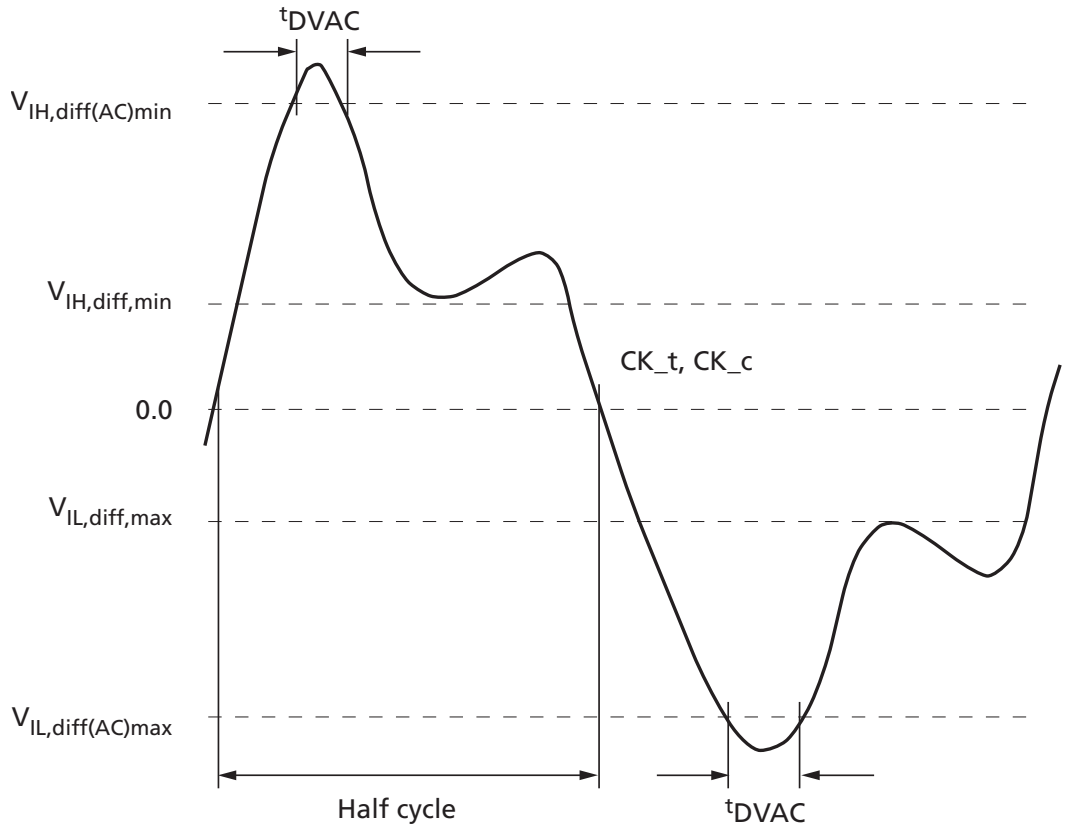
**Figure 209: CT Type-D Input Slew Rate Definition**



## Electrical Characteristics – AC and DC Differential Input Measurement Levels

### Differential Inputs

Figure 210: Differential AC Swing and “Time Exceeding AC-Level”  $t_{DVAC}$



- Notes: 1. Differential signal rising edge from  $V_{IL,diff,max}$  to  $V_{IH,diff(AC)min}$  must be monotonic slope.  
 2. Differential signal falling edge from  $V_{IH,diff,min}$  to  $V_{IL,diff(AC)max}$  must be monotonic slope.

Table 91: Differential Input Swing Requirements for CK<sub>t</sub>, CK<sub>c</sub>

Parameter	Symbol	DDR4-1600 / 1866 / 2133 / 2400		DDR4-2666 / 2933 / 3200		Unit	Notes
		Min	Max	Min	Max		
Differential input high	$V_{IHdiff}$	0.150	Note 3	0.120	Note 3	V	1
Differential input low	$V_{ILDdiff}$	Note 3	-0.150	Note 3	-0.120	V	1
Differential input high (AC)	$V_{IHdiff(AC)}$	$2 \times (V_{IH(AC)} - V_{REF})$	Note 3	$2 \times (V_{IH(AC)} - V_{REF})$	Note 3	V	2
Differential input low (AC)	$V_{ILDdiff(AC)}$	Note 3	$2 \times (V_{IL(AC)} - V_{REF})$	Note 3	$2 \times (V_{IL(AC)} - V_{REF})$	V	2

- Notes: 1. Used to define a differential signal slew-rate.  
 2. For CK<sub>t</sub>, CK<sub>c</sub> use  $V_{IH(AC)}$  and  $V_{IL(AC)}$  of ADD/CMD and  $V_{REFCA}$ .

3. These values are not defined; however, the differential signals (CK\_t, CK\_c) need to be within the respective limits,  $V_{IH(DC)max}$  and  $V_{IL(DC)min}$  for single-ended signals as well as the limitations for overshoot and undershoot.

**Table 92: Minimum Time AC Time  $t_{DVAC}$  for CK**

Slew Rate (V/ns)	$t_{DVAC}$ (ps) at $ V_{IH,diff(AC)} \text{ to } V_{IL,diff(AC)} $	
	200mV	TBDmV
>4.0	120	TBD
4.0	115	TBD
3.0	110	TBD
2.0	105	TBD
1.9	100	TBD
1.6	95	TBD
1.4	90	TBD
1.2	85	TBD
1.0	80	TBD
<1.0	80	TBD

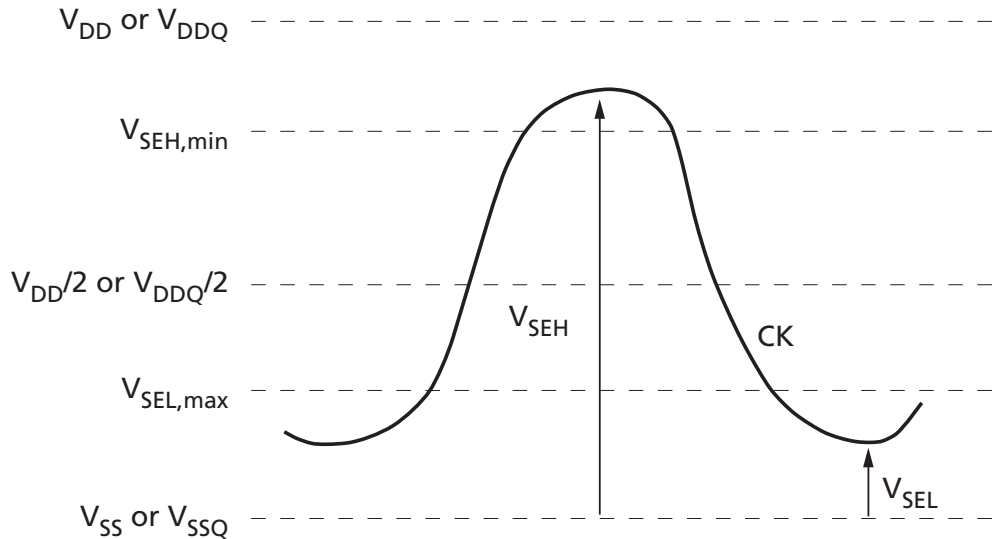
Note: 1. Below  $V_{IL(AC)}$ .

### Single-Ended Requirements for CK Differential Signals

Each individual component of a differential signal (CK\_t, CK\_c) has to comply with certain requirements for single-ended signals. CK\_t and CK\_c have to reach approximately  $V_{SEHmin}/V_{SEL,max}$ , which are approximately equal to the AC levels  $V_{IH(AC)}$  and  $V_{IL(AC)}$  for ADD/CMD signals in every half-cycle. The applicable AC levels for ADD/CMD might differ per speed-bin, and so on. For example, if a value other than 100mV is used for ADD/CMD  $V_{IH(AC)}$  and  $V_{IL(AC)}$  signals, then these AC levels also apply for the single-ended signals CK\_t and CK\_c.

While ADD/CMD signal requirements are with respect to  $V_{REFCA}$ , the single-ended components of differential signals have a requirement with respect to  $V_{DD}/2$ ; this is nominally the same. The transition of single-ended signals through the AC levels is used to measure setup time. For single-ended components of differential signals the requirement to reach  $V_{SEL,max}/V_{SEH,min}$  has no bearing on timing, but adds a restriction on the common mode characteristics of these signals.

**Figure 211: Single-Ended Requirements for CK**



**Table 93: Single-Ended Requirements for CK**

Parameter	Symbol	DDR4-1600 / 1866 / 2133 / 2400		DDR4-2666 / 2933 / 3200		Unit	Notes
		Min	Max	Min	Max		
Single-ended high level for CK_t, CK_c	$V_{SEH}$	$V_{DD}/2 + 0.100$	Note 3	$V_{DD}/2 + 0.90$	Note 3	V	1, 2
Single-ended low level for CK_t, CK_c	$V_{SEL}$	Note 3	$V_{DD}/2 - 0.100$	Note 3	$V_{DD}/2 - 0.90$	V	1, 2

- Notes:
1. For CK\_t, CK\_c use  $V_{IH(AC)}$  and  $V_{IL(AC)}$  of ADD/CMD and  $V_{REFCA}$ .
  2. ADDR/CMD  $V_{IH(AC)}$  and  $V_{IL(AC)}$  based on  $V_{REFCA}$ .
  3. These values are not defined; however, the differential signal (CK\_t, CK\_c) need to be within the respective limits,  $V_{IH(DC)max}$  and  $V_{IL(DC)min}$  for single-ended signals as well as the limitations for overshoot and undershoot.

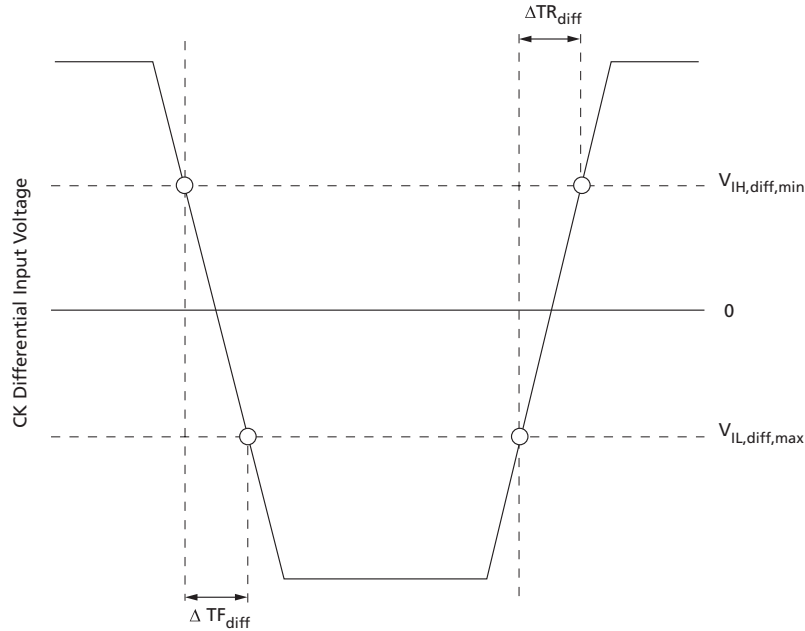
### Slew Rate Definitions for CK Differential Input Signals

**Table 94: CK Differential Input Slew Rate Definition**

Description	Measured		Defined by
	From	To	
Differential input slew rate for rising edge	$V_{IL,diff,max}$	$V_{IH,diff,min}$	$ V_{IH,diff,min} - V_{IL,diff,max} /\Delta T_{R,diff}$
Differential input slew rate for falling edge	$V_{IH,diff,min}$	$V_{IL,diff,max}$	$ V_{IH,diff,min} - V_{IL,diff,max} /\Delta T_{F,diff}$

- Note: 1. The differential signal CK\_t, CK\_c must be monotonic between these thresholds.

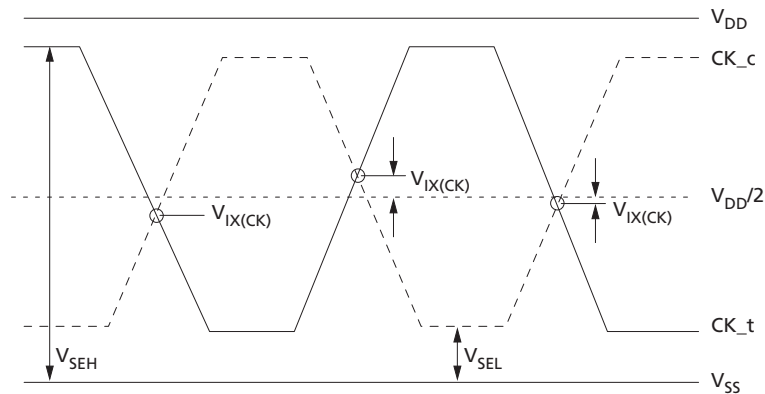
Figure 212: Differential Input Slew Rate Definition for CK\_t, CK\_c



### CK Differential Input Cross Point Voltage

To guarantee tight setup and hold times as well as output skew parameters with respect to clock and strobe, each cross point voltage of differential input signal CK\_t, CK\_c must meet the requirements shown below. The differential input cross point voltage  $V_{IX(CK)}$  is measured from the actual cross point of true and complement signals to the midlevel between  $V_{DD}$  and  $V_{SS}$ .

Figure 213:  $V_{IX(CK)}$  Definition



**Table 95: Cross Point Voltage For CK Differential Input Signals at DDR4-1600 through DDR4-2400**

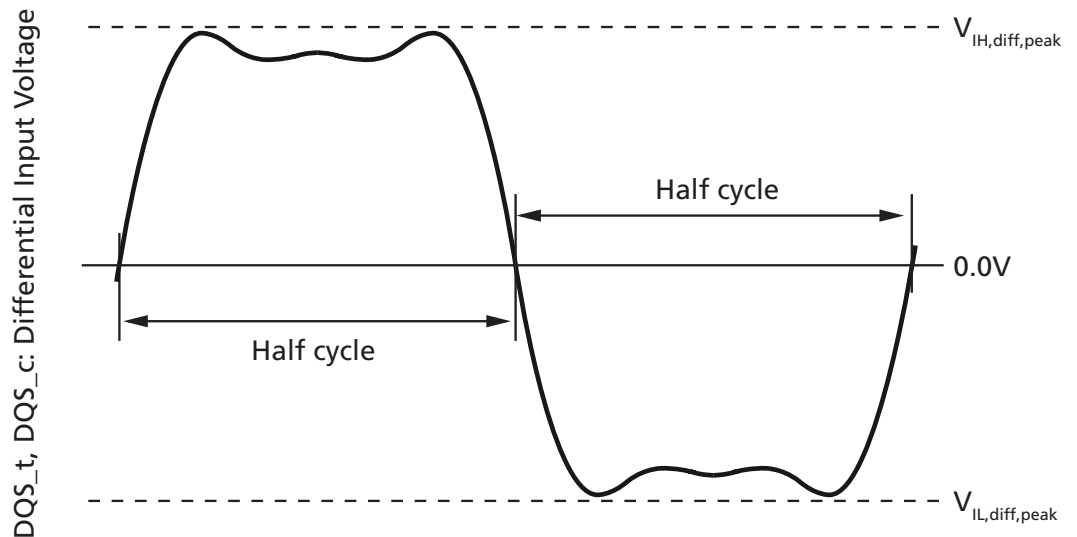
Parameter	Sym	Input Level	DDR4-1600, 1866, 2133		DDR4-2400	
			Min	Max	Min	Max
Differential input cross point voltage relative to $V_{DD}/2$ for CK_t, CK_c	$V_{IX(CK)}$	$V_{SEH} > V_{DD}/2 + 145\text{mV}$	N/A	120mV	N/A	120mV
		$V_{DD}/2 + 100\text{mV} \leq V_{SEH} \leq V_{DD}/2 + 145\text{mV}$	N/A	$(V_{SEH} - V_{DD}/2) - 25\text{mV}$	N/A	$(V_{SEH} - V_{DD}/2) - 25\text{mV}$
		$V_{DD}/2 - 145\text{mV} \leq V_{SEL} \leq V_{DD}/2 - 100\text{mV}$	$-(V_{DD}/2 - V_{SEL}) + 25\text{mV}$	N/A	$-(V_{DD}/2 - V_{SEL}) + 25\text{mV}$	N/A
		$V_{SEL} \leq V_{DD}/2 - 145\text{mV}$	-120mV	N/A	-120mV	N/A

**Table 96: Cross Point Voltage For CK Differential Input Signals at DDR4-2666 through DDR4-3200**

Parameter	Sym	Input Level	DDR4-2666		DDR4-2933, 3200	
			Min	Max	Min	Max
Differential input cross point voltage relative to $V_{DD}/2$ for CK_t, CK_c	$V_{IX(CK)}$	$V_{SEH} > V_{DD}/2 + 135\text{mV}$	N/A	110mV	N/A	110mV
		$V_{DD}/2 + 90\text{mV} \leq V_{SEH} \leq V_{DD}/2 + 135\text{mV}$	N/A	$(V_{SEH} - V_{DD}/2) - 30\text{mV}$	N/A	$(V_{SEH} - V_{DD}/2) - 30\text{mV}$
		$V_{DD}/2 - 135\text{mV} \leq V_{SEL} \leq V_{DD}/2 - 90\text{mV}$	$-(V_{DD}/2 - V_{SEL}) + 30\text{mV}$	N/A	$-(V_{DD}/2 - V_{SEL}) + 30\text{mV}$	N/A
		$V_{SEL} \leq V_{DD}/2 - 135\text{mV}$	-110mV	N/A	-110mV	N/A

### DQS Differential Input Signal Definition and Swing Requirements

**Figure 214: Differential Input Signal Definition for DQS\_t, DQS\_c**



**Table 97: DDR4-1600 through DDR4-2400 Differential Input Swing Requirements for DQS\_t, DQS\_c**

Parameter	Symbol	DDR4-1600, 1866, 2133		DDR4-2400		Unit	Notes
		Min	Max	Min	Max		
Peak differential input high voltage	$V_{IH,diff,peak}$	186	$V_{DDQ}$	160	$V_{DDQ}$	mV	1, 2
Peak differential input low voltage	$V_{IL,diff,peak}$	$V_{SSQ}$	-186	$V_{SSQ}$	-160	mV	1, 2

- Notes: 1. Minimum and maximum limits are relative to single-ended portion and can be exceeded within allowed overshoot and undershoot limits.  
 2. Minimum value point is used to determine differential signal slew-rate.

**Table 98: DDR4-2633 through DDR4-3200 Differential Input Swing Requirements for DQS\_t, DQS\_c**

Parameter	Symbol	DDR4-2666		DDR4-2933		DDR4-3200		Unit	Notes
		Min	Max	Min	Max	Min	Max		
Peak differential input high voltage	$V_{IH,diff,peak}$	150	$V_{DDQ}$	145	$V_{DDQ}$	140	$V_{DDQ}$	mV	1, 2
Peak differential input low voltage	$V_{IL,diff,peak}$	$V_{SSQ}$	-150	$V_{SSQ}$	-145	$V_{SSQ}$	-140	mV	1, 2

- Notes: 1. Minimum and maximum limits are relative to single-ended portion and can be exceeded within allowed overshoot and undershoot limits.  
 2. Minimum value point is used to determine differential signal slew-rate.

The peak voltage of the DQS signals are calculated using the following equations:

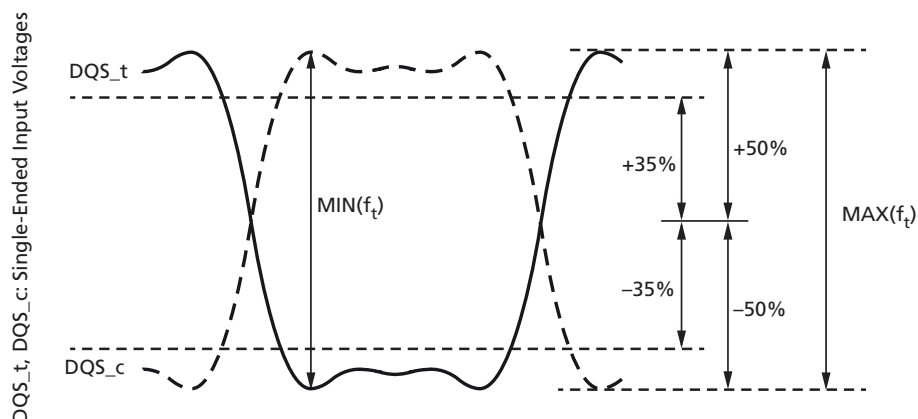
$$V_{IH,dif,Peak} \text{ voltage} = \text{MAX}(f_t)$$

$$V_{IL,dif,Peak} \text{ voltage} = \text{MIN}(f_t)$$

$$(f_t) = \text{DQS}_t, \text{DQS}_c.$$

The MAX(f(t)) or MIN(f(t)) used to determine the midpoint from which to reference the ±35% window of the exempt non-monotonic signaling shall be the smallest peak voltage observed in all UIs.

**Figure 215: DQS\_t, DQS\_c Input Peak Voltage Calculation and Range of Exempt non-Monotonic Signaling**



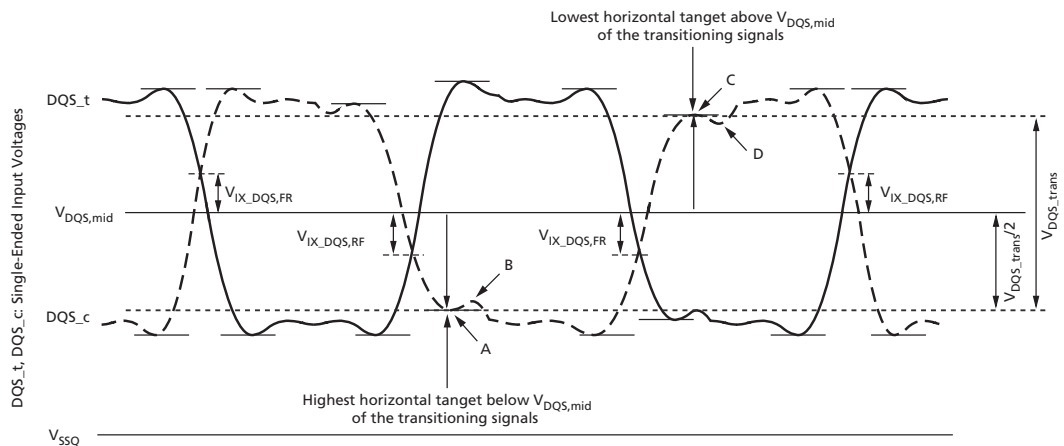
### DQS Differential Input Cross Point Voltage

To achieve tight RxMask input requirements as well as output skew parameters with respect to strobe, the cross point voltage of differential input signals (DQS\_t, DQS\_c) must meet  $V_{IX\_DQS, ratio}$  in the table below. The differential input cross point voltage  $V_{IX\_DQS}$  ( $V_{IX\_DQS\_FR}$  and  $V_{IX\_DQS\_RF}$ ) is measured from the actual cross point of DQS\_t, DQS\_c relative to the  $V_{DQS, mid}$  of the DQS\_t and DQS\_c signals.

$V_{DQS, mid}$  is the midpoint of the minimum levels achieved by the transitioning DQS\_t and DQS\_c signals, and noted by  $V_{DQS\_trans}$ .  $V_{DQS\_trans}$  is the difference between the lowest horizontal tangent above  $V_{DQS, mid}$  of the transitioning DQS signals and the highest horizontal tangent below  $V_{DQS, mid}$  of the transitioning DQS signals. A non-monotonic transitioning signal's ledge is exempt or not used in determination of a horizontal tangent provided the said ledge occurs within  $\pm 35\%$  of the midpoint of either  $V_{IH, DIFF, Peak}$  voltage (DQS\_t rising) or  $V_{IL, DIFF, Peak}$  voltage (DQS\_c rising), as shown in the figure below.

A secondary horizontal tangent resulting from a ring-back transition is also exempt in determination of a horizontal tangent. That is, a falling transition's horizontal tangent is derived from its negative slope to zero slope transition (point A in the figure below), and a ring-back's horizontal tangent is derived from its positive slope to zero slope transition (point B in the figure below) and is not a valid horizontal tangent; a rising transition's horizontal tangent is derived from its positive slope to zero slope transition (point C in the figure below), and a ring-back's horizontal tangent derived from its negative slope to zero slope transition (point D in the figure below) and is not a valid horizontal tangent.

**Figure 216:  $V_{IXDQS}$  Definition**



**Table 99: Cross Point Voltage For Differential Input Signals DQS**

Parameter	Symbol	DDR4-1600, 1866, 2133, 2400, 2666, 2933, 3200		Unit	Notes
		Min	Max		
DQS_t and DQS_c crossing relative to the midpoint of the DQS_t and DQS_c signal swings	$V_{IX\_DQS, ratio}$	–	25	%	1, 2

**Table 99: Cross Point Voltage For Differential Input Signals DQS (Continued)**

Parameter	Symbol	DDR4-1600, 1866, 2133, 2400, 2666, 2933, 3200		Unit	Notes
		Min	Max		
$V_{DQS,mid}$ to $V_{cent(midpoint)}$ offset	$V_{DQS,mid\_to\_Vcent}$	–	Note 3	mV	2

- Notes:
- $V_{IX\_DQS,ratio}$  is DQS  $V_{IX}$  crossing ( $V_{IX\_DQS,FR}$  or  $V_{IX\_DQS,RF}$ ) divided by  $V_{DQS\_trans}$ .  $V_{DQS\_trans}$  is the difference between the lowest horizontal tangent above  $V_{DQS,mid}$  of the transitioning DQS signals and the highest horizontal tangent below  $V_{DQS,mid}$  of the transitioning DQS signals.
  - $V_{DQS,mid}$  will be similar to the  $V_{REFDQ}$  internal setting value ( $V_{cent(midpoint)}$  offset) obtained during  $V_{REF}$  Training if the DQS and DQs drivers and paths are matched.
  - The maximum limit shall not exceed the smaller of  $V_{IH,diff,DQS}$  minimum limit or 50mV.

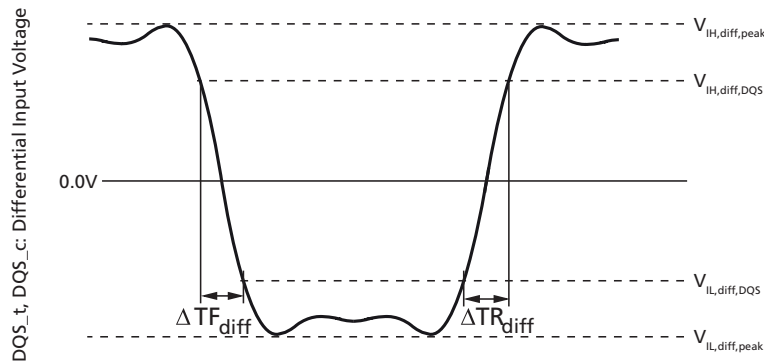
### Slew Rate Definitions for DQS Differential Input Signals

**Table 100: DQS Differential Input Slew Rate Definition**

Description	Measured		Defined by
	From	To	
Differential input slew rate for rising edge	$V_{IL,diff,DQS}$	$V_{IH,diff,DQS}$	$ V_{IH,diff,DQS} - V_{IL,diff,DQS}  / \Delta TR_{diff}$
Differential input slew rate for falling edge	$V_{IH,diff,DQS}$	$V_{IL,diff,DQS}$	$ V_{IH,diff,DQS} - V_{IL,diff,DQS}  / \Delta TF_{diff}$

- Note: 1. The differential signal DQS\_t, DQS\_c must be monotonic between these thresholds.

**Figure 217: Differential Input Slew Rate and Input Level Definition for DQS\_t, DQS\_c**



**Table 101: DDR4-1600 through DDR4-2400 Differential Input Slew Rate and Input Levels for DQS\_t, DQS\_c**

Parameter	Symbol	DDR4-1600, 1866, 2133		DDR4-2400		Unit	Notes
		Min	Max	Min	Max		
Peak differential input high voltage	$V_{IH,diff,peak}$	186	$V_{DDQ}$	160	$V_{DDQ}$	mV	1
Differential input high voltage	$V_{IH,diff,DQS}$	136	–	130	–	mV	2, 3
Differential input low voltage	$V_{IL,diff,DQS}$	–	–136	–	–130	mV	2, 3

**Table 101: DDR4-1600 through DDR4-2400 Differential Input Slew Rate and Input Levels for DQS\_t, DQS\_c (Continued)**

Parameter	Symbol	DDR4-1600, 1866, 2133		DDR4-2400		Unit	Notes
		Min	Max	Min	Max		
Peak differential input low voltage	$V_{IL,diff,peak}$	$V_{SSQ}$	-186	$V_{SSQ}$	-160	mV	1
DQS differential input slew rate	SRIdiff	3.0	18	3.0	18	V/ns	4, 5

- Notes:
1. Minimum and maximum limits are relative to single-ended portion and can be exceeded within allowed overshoot and undershoot limits.
  2. Differential signal rising edge from  $V_{IL,diff,DQS}$  to  $V_{IH,diff,DQS}$  must be monotonic slope.
  3. Differential signal falling edge from  $V_{IH,diff,DQS}$  to  $V_{IL,diff,DQS}$  must be monotonic slope.
  4. Differential input slew rate for rising edge from  $V_{IL,diff,DQS}$  to  $V_{IH,diff,DQS}$  is defined by  $|V_{IL,diff,min} - V_{IH,diff,max}|/\Delta TR_{diff}$ .
  5. Differential input slew rate for falling edge from  $V_{IH,diff,DQS}$  to  $V_{IL,diff,DQS}$  is defined by  $|V_{IL,diff,min} - V_{IH,diff,max}|/\Delta TF_{diff}$ .

**Table 102: DDR4-2666 through DDR4-3200 Differential Input Slew Rate and Input Levels for DQS\_t, DQS\_c**

Parameter	Symbol	DDR4-2666		DDR4-2933		DDR4-3200		Unit	Notes
		Min	Max	Min	Max	Min	Max		
Peak differential input high voltage	$V_{IH,diff,peak}$	150	$V_{DDQ}$	145	$V_{DDQ}$	140	$V_{DDQ}$	mV	1
Differential input high voltage	$V_{IH,diff,DQS}$	120	-	115	-	110	-	mV	2, 3
Differential input low voltage	$V_{IL,diff,DQS}$	-	-120	-	-115	-	-110	mV	2, 3
Peak differential input low voltage	$V_{IL,diff,peak}$	$V_{SSQ}$	-150	$V_{SSQ}$	-145	$V_{SSQ}$	-140	mV	1
DQS differential input slew rate	SRIdiff	3.0	18	3.0	18	3.0	18	V/ns	4, 5

- Notes:
1. Minimum and maximum limits are relative to single-ended portion and can be exceeded within allowed overshoot and undershoot limits.
  2. Differential signal rising edge from  $V_{IL,diff,DQS}$  to  $V_{IH,diff,DQS}$  must be monotonic slope.
  3. Differential signal falling edge from  $V_{IH,diff,DQS}$  to  $V_{IL,diff,DQS}$  must be monotonic slope.
  4. Differential input slew rate for rising edge from  $V_{IL,diff,DQS}$  to  $V_{IH,diff,DQS}$  is defined by  $|V_{IL,diff,min} - V_{IH,diff,max}|/\Delta TR_{diff}$ .
  5. Differential input slew rate for falling edge from  $V_{IH,diff,DQS}$  to  $V_{IL,diff,DQS}$  is defined by  $|V_{IL,diff,min} - V_{IH,diff,max}|/\Delta TF_{diff}$ .

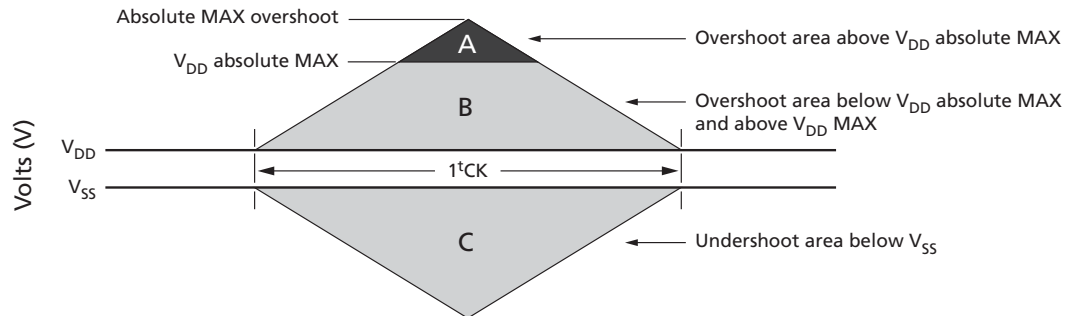
## Electrical Characteristics – Overshoot and Undershoot Specifications

### Address, Command, and Control Overshoot and Undershoot Specifications

**Table 103: ADDR, CMD, CNTL Overshoot and Undershoot/Specifications**

Description	DDR4-1600	DDR4-1866	DDR4-2133	DDR4-2400	DDR4-2666	DDR4-3200	Unit
<b>Address and control pins (A[17:0], BG[1:0], BA[1:0], CS_n, RAS_n, CAS_n, WE_n, CKE, ODT, C2-0)</b>							
Area A: Maximum peak amplitude above $V_{DD}$ absolute MAX	0.06	0.06	0.06	0.06	TBD	TBD	V
Area B: Amplitude allowed between $V_{DD}$ and $V_{DD}$ absolute MAX	0.24	0.24	0.24	0.24	TBD	TBD	V
Area C: Maximum peak amplitude allowed for undershoot below $V_{SS}$	0.30	0.30	0.30	0.30	TBD	TBD	V
Area A maximum overshoot area per $1^tCK$	0.0083	0.0071	0.0062	0.0055	TBD	TBD	V/ns
Area B maximum overshoot area per $1^tCK$	0.2550	0.2185	0.1914	0.1699	TBD	TBD	V/ns
Area C maximum undershoot area per $1^tCK$	0.2644	0.2265	0.1984	0.1762	TBD	TBD	V/ns

**Figure 218: ADDR, CMD, CNTL Overshoot and Undershoot Definition**

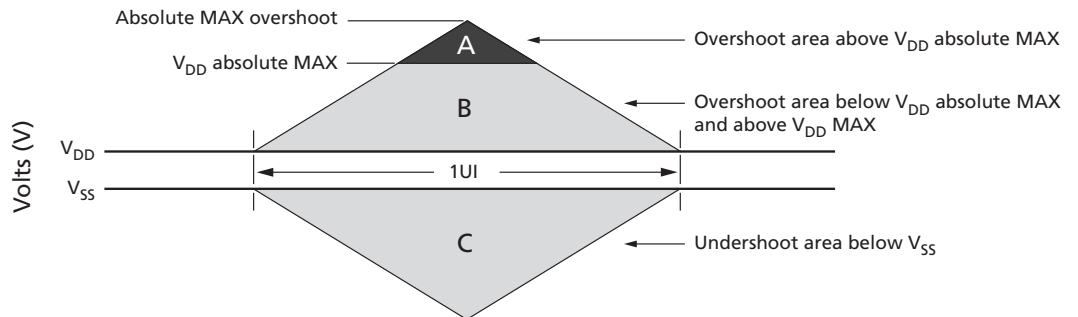


### Clock Overshoot and Undershoot Specifications

**Table 104: CK Overshoot and Undershoot/ Specifications**

Description	DDR4-1600	DDR4-1866	DDR4-2133	DDR4-2400	DDR4-2666	DDR4-3200	Unit
<b>CK<sub>t</sub>, CK<sub>c</sub></b>							
Area A: Maximum peak amplitude above V <sub>DD</sub> absolute MAX	0.06	0.06	0.06	0.06	TBD	TBD	V
Area B: Amplitude allowed between V <sub>DD</sub> and V <sub>DD</sub> absolute MAX	0.24	0.24	0.24	0.24	TBD	TBD	V
Area C: Maximum peak amplitude allowed for undershoot below V <sub>SS</sub>	0.30	0.30	0.30	0.30	TBD	TBD	V
Area A maximum overshoot area per 1UI	0.0038	0.0032	0.0028	0.0025	TBD	TBD	V/ns
Area B maximum overshoot area per 1UI	0.1125	0.0964	0.0844	0.0750	TBD	TBD	V/ns
Area C maximum undershoot area per 1UI	0.1144	0.0980	0.0858	0.0762	TBD	TBD	V/ns

**Figure 219: CK Overshoot and Undershoot Definition**

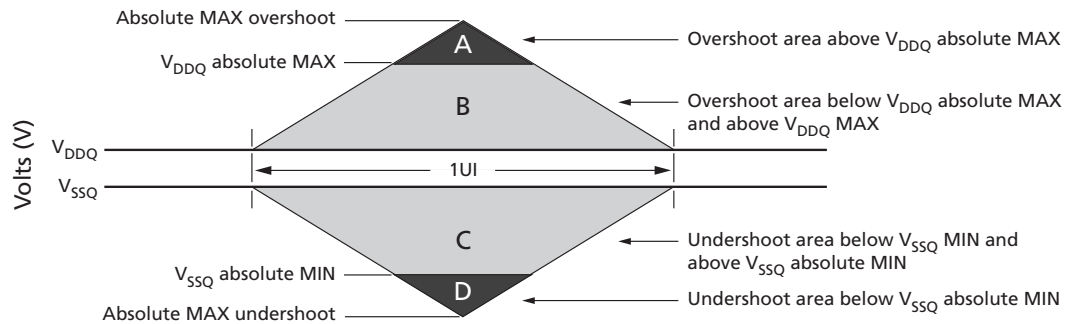


## Data, Strobe, and Mask Overshoot and Undershoot Specifications

**Table 105: Data, Strobe, and Mask Overshoot and Undershoot/ Specifications**

Description	DDR4-1600	DDR4-1866	DDR4-2133	DDR4-2400	DDR4-2666	DDR4-3200	Unit
<b>Data, Strobe, and Mask</b>							
Area A: Maximum peak amplitude above $V_{DDQ}$ absolute MAX	0.16	0.16	0.16	0.16	TBD	TBD	V
Area B: Amplitude allowed between $V_{DDQ}$ and $V_{DDQ}$ absolute MAX	0.24	0.24	0.24	0.24	TBD	TBD	V
Area C: Maximum peak amplitude allowed for undershoot below $V_{SSQ}$	0.30	0.30	0.30	0.30	TBD	TBD	V
Area D: Maximum peak amplitude below $V_{SSQ}$ absolute MIN	0.10	0.10	0.10	0.10	TBD	TBD	V
Area A maximum overshoot area per 1UI	0.0150	0.0129	0.0113	0.0100	TBD	TBD	V/ns
Area B maximum overshoot area per 1UI	0.1050	0.0900	0.0788	0.0700	TBD	TBD	V/ns
Area C maximum undershoot area per 1UI	0.1050	0.0900	0.0788	0.0700	TBD	TBD	V/ns
Area D maximum undershoot area per 1UI	0.0150	0.0129	0.0113	0.0100	TBD	TBD	V/ns

**Figure 220: Data, Strobe, and Mask Overshoot and Undershoot Definition**



## Electrical Characteristics – AC and DC Output Measurement Levels

### Single-Ended Outputs

**Table 106: Single-Ended Output Levels**

Parameter	Symbol	DDR4-1600 to DDR4-3200	Unit
DC output high measurement level (for IV curve linearity)	$V_{OH(DC)}$	$1.1 \times V_{DDQ}$	V
DC output mid measurement level (for IV curve linearity)	$V_{OM(DC)}$	$0.8 \times V_{DDQ}$	V
DC output low measurement level (for IV curve linearity)	$V_{OL(DC)}$	$0.5 \times V_{DDQ}$	V
AC output high measurement level (for output slew rate)	$V_{OH(AC)}$	$(0.7 + 0.15) \times V_{DDQ}$	V

**Table 106: Single-Ended Output Levels (Continued)**

Parameter	Symbol	DDR4-1600 to DDR4-3200	Unit
AC output low measurement level (for output slew rate)	$V_{OL(AC)}$	$(0.7 - 0.15) \times V_{DDQ}$	V

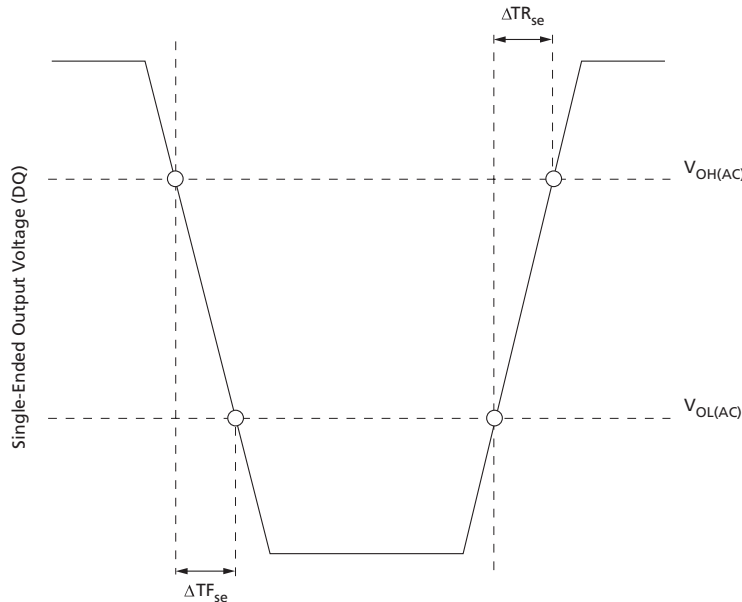
Note: 1. The swing of  $\pm 0.15 \times V_{DDQ}$  is based on approximately 50% of the static single-ended output peak-to-peak swing with a driver impedance of  $RZQ/7$  and an effective test load of  $50\Omega$  to  $V_{TT} = V_{DDQ}$ .

Using the same reference load used for timing measurements, output slew rate for falling and rising edges is defined and measured between  $V_{OL(AC)}$  and  $V_{OH(AC)}$  for single-ended signals.

**Table 107: Single-Ended Output Slew Rate Definition**

Description	Measured		Defined by
	From	To	
Single-ended output slew rate for rising edge	$V_{OL(AC)}$	$V_{OH(AC)}$	$[V_{OH(AC)} - V_{OL(AC)}] / \Delta TR_{se}$
Single-ended output slew rate for falling edge	$V_{OH(AC)}$	$V_{OL(AC)}$	$[V_{OH(AC)} - V_{OL(AC)}] / \Delta TF_{se}$

**Figure 221: Single-ended Output Slew Rate Definition**



**Table 108: Single-Ended Output Slew Rate**

For  $R_{ON} = R_{ZQ}/7$

Parameter	Symbol	DDR4-1333 / 1866 / 2133 / 2400		DDR4-2666		DDR4-2933 / 3200		Unit
		Min	Max	Min	Max	Min	Max	
Single-ended output slew rate	$SR_{Q_{se}}$	4	9	4	9	4	9	V/ns

- Notes:
- SR = slew rate; Q = query output; se = single-ended signals
  - In two cases a maximum slew rate of 12V/ns applies for a single DQ signal within a byte lane:
    - Case 1 is defined for a single DQ signal within a byte lane that is switching into a certain direction (either from HIGH-to-LOW or LOW-to-HIGH) while all remaining DQ signals in the same byte lane are static (they stay at either HIGH or LOW).
    - Case 2 is defined for a single DQ signal within a byte lane that is switching into a certain direction (either from HIGH-to-LOW or LOW-to-HIGH) while all remaining DQ signals in the same byte lane are switching into the opposite direction (from LOW-to-HIGH or HIGH-to-LOW, respectively). For the remaining DQ signal switching into the opposite direction, the standard maximum limit of 9 V/ns applies.

## Differential Outputs

**Table 109: Differential Output Levels**

Parameter	Symbol	DDR4-1600 to DDR4-3200	Unit
AC differential output high measurement level (for output slew rate)	$V_{OH,diff(AC)}$	$0.3 \times V_{DDQ}$	V
AC differential output low measurement level (for output slew rate)	$V_{OL,diff(AC)}$	$-0.3 \times V_{DDQ}$	V

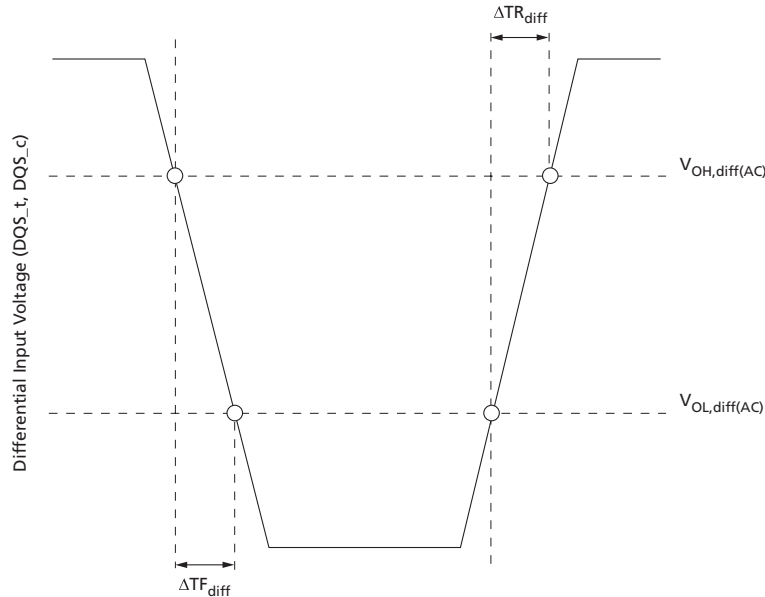
Note: 1. The swing of  $\pm 0.3 \times V_{DDQ}$  is based on approximately 50% of the static single-ended output peak-to-peak swing with a driver impedance of  $R_{ZQ}/7$  and an effective test load of  $50\Omega$  to  $V_{TT} = V_{DDQ}$  at each differential output.

Using the same reference load used for timing measurements, output slew rate for falling and rising edges is defined and measured between  $V_{OL,diff(AC)}$  and  $V_{OH,diff(AC)}$  for differential signals.

**Table 110: Differential Output Slew Rate Definition**

Description	Measured		Defined by
	From	To	
Differential output slew rate for rising edge	$V_{OL,diff(AC)}$	$V_{OH,diff(AC)}$	$[V_{OH,diff(AC)} - V_{OL,diff(AC)}] / \Delta TR_{diff}$
Differential output slew rate for falling edge	$V_{OH,diff(AC)}$	$V_{OL,diff(AC)}$	$[V_{OH,diff(AC)} - V_{OL,diff(AC)}] / \Delta TF_{diff}$

**Figure 222: Differential Output Slew Rate Definition**



**Table 111: Differential Output Slew Rate**

For  $R_{ON} = R_{ZQ}/7$

Parameter	Symbol	DDR4-1333 / 1866 / 2133 / 2400		DDR4-2666		DDR4-2933 / 3200		Unit
		Min	Max	Min	Max	Min	Max	
Differential output slew rate	$SRQ_{diff}$	8	18	8	18	8	18	V/ns

Note: 1. SR = slew rate; Q = query output; diff = differential signals.

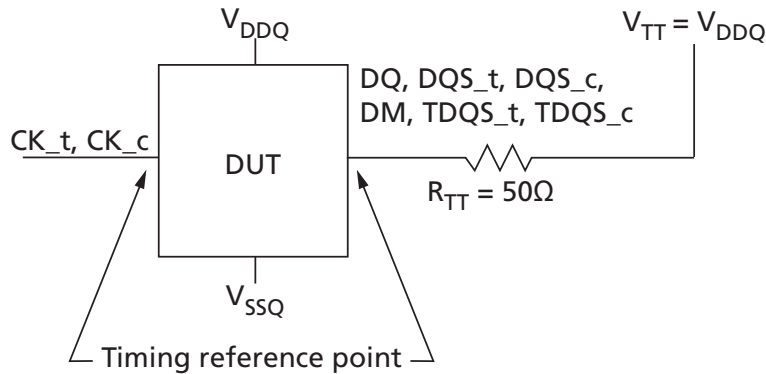
### Reference Load for AC Timing and Output Slew Rate

The effective reference load of  $50\Omega$  to  $V_{TT} = V_{DDQ}$  and driver impedance of  $R_{ZQ}/7$  for each output was used in defining the relevant AC timing parameters of the device as well as output slew rate measurements.

Ron nominal of DQ, DQS<sub>t</sub> and DQS<sub>c</sub> drivers uses 34 ohms to specify the relevant AC timing parameter values of the device. The maximum DC High level of Output signal =  $1.0 * V_{DDQ}$ , the minimum DC Low level of Output signal =  $\{ 34 / ( 34 + 50 ) \} * V_{DDQ} = 0.4 * V_{DDQ}$

The nominal reference level of an Output signal can be approximated by the following: The center of maximum DC High and minimum DC Low =  $\{ ( 1 + 0.4 ) / 2 \} * V_{DDQ} = 0.7 * V_{DDQ}$ . The actual reference level of Output signal might vary with driver Ron and reference load tolerances. Thus, the actual reference level or midpoint of an output signal is at the widest part of the output signal's eye.

**Figure 223: Reference Load For AC Timing and Output Slew Rate**



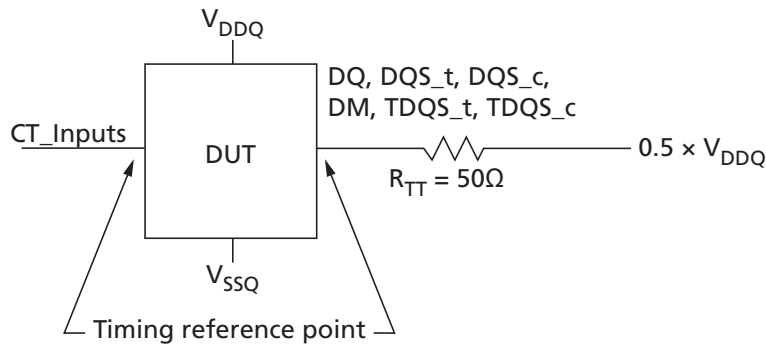
### Connectivity Test Mode Output Levels

**Table 112: Connectivity Test Mode Output Levels**

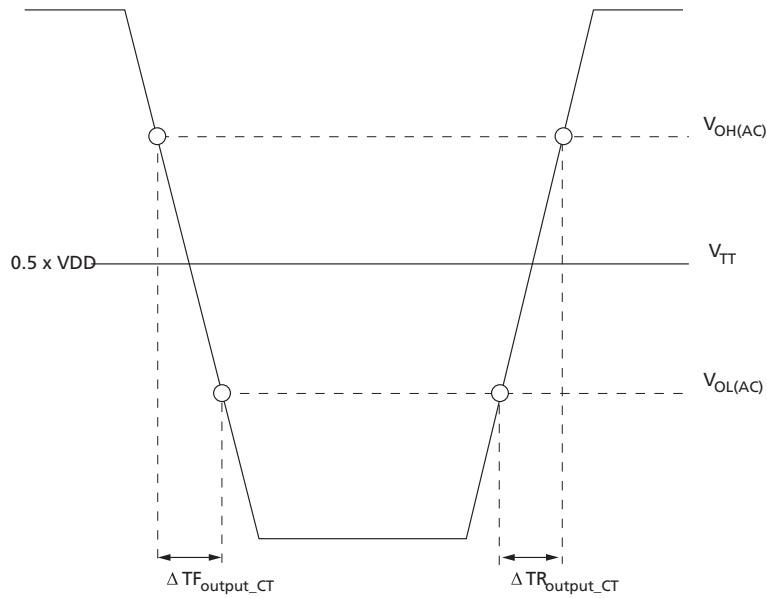
Parameter	Symbol	DDR4-1600 to DDR4-3200	Unit
DC output high measurement level (for IV curve linearity)	$V_{OH(DC)}$	$1.1 \times V_{DDQ}$	V
DC output mid measurement level (for IV curve linearity)	$V_{OM(DC)}$	$0.8 \times V_{DDQ}$	V
DC output low measurement level (for IV curve linearity)	$V_{OL(DC)}$	$0.5 \times V_{DDQ}$	V
DC output below measurement level (for IV curve linearity)	$V_{OB(DC)}$	$0.2 \times V_{DDQ}$	V
AC output high measurement level (for output slew rate)	$V_{OH(AC)}$	$V_{TT} + (0.1 \times V_{DDQ})$	V
AC output low measurement level (for output slew rate)	$V_{OL(AC)}$	$V_{TT} - (0.1 \times V_{DDQ})$	V

Note: 1. Driver impedance of  $R_{ZQ}/7$  and an effective test load of  $50\Omega$  to  $V_{TT} = V_{DDQ}$ .

**Figure 224: Connectivity Test Mode Reference Test Load**



**Figure 225: Connectivity Test Mode Output Slew Rate Definition**



**Table 113: Connectivity Test Mode Output Slew Rate**

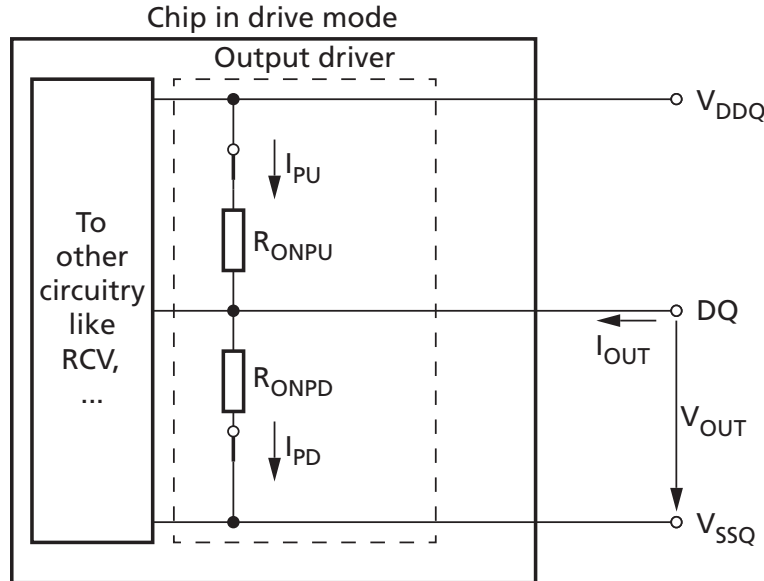
Parameter	Symbol	DDR4-1333 / 1866 / 2133 / 2400		DDR4-2666		DDR4-2933 / 3200		Unit
		Min	Max	Min	Max	Min	Max	
Output signal falling time	TF_output_CT	–	10	–	10	–	10	ns/V
Output signal rising time	TR_output_CT	–	10	–	10	–	10	ns/V

## Electrical Characteristics – AC and DC Output Driver Characteristics

### Output Driver Electrical Characteristics

The DDR4 driver supports two  $R_{ON}$  values. These  $R_{ON}$  values are referred to as strong mode (low  $R_{ON}$ : 34Ω) and weak mode (high  $R_{ON}$ : 48Ω). A functional representation of the output driver is shown in the figure below.

Figure 226: Output Driver: Definition of Voltages and Currents



The output driver impedance,  $R_{ON}$ , is determined by the value of the external reference resistor  $R_{ZQ}$  as follows:  $R_{ON(34)} = R_{ZQ}/7$ , or  $R_{ON(48)} = R_{ZQ}/5$ . This provides either a nominal  $34.3\Omega \pm 10\%$  or  $48\Omega \pm 10\%$  with nominal  $R_{ZQ} = 240\Omega$ .

The individual pull-up and pull-down resistors ( $R_{ONPU}$  and  $R_{ONPD}$ ) are defined as follows:

$R_{ONPU}$  when  $R_{ONPD}$  is off:

$$R_{ONPU} = \frac{V_{DDQ} - V_{OUT}}{|I_{OUT}|}$$

$R_{ONPD}$  when  $R_{ONPU}$  is off:

$$R_{ONPD} = \frac{V_{OUT}}{|I_{OUT}|}$$

**Table 114: Strong Mode (34Ω) Output Driver Electrical Characteristics**

Assumes  $R_{ZQ} = 240\Omega$ ; Entire operating temperature range after proper ZQ calibration

$R_{ON,nom}$	Resistor	$V_{OUT}$	Min	Nim	Max	Unit	Notes
34Ω	$R_{ON34PD}$	$V_{OL(DC)} = 0.5 \times V_{DDQ}$	0.8	1.0	1.1	$R_{ZQ}/7$	1, 2, 3
		$V_{OM(DC)} = 0.8 \times V_{DDQ}$	0.9	1.0	1.1	$R_{ZQ}/7$	1, 2, 3
		$V_{OH(DC)} = 1.1 \times V_{DDQ}$	0.9	1.0	1.25	$R_{ZQ}/7$	1, 2, 3
	$R_{ON34PU}$	$V_{OL(DC)} = 0.5 \times V_{DDQ}$	0.9	1.0	1.25	$R_{ZQ}/7$	1, 2, 3
		$V_{OM(DC)} = 0.8 \times V_{DDQ}$	0.9	1.0	1.1	$R_{ZQ}/7$	1, 2, 3
		$V_{OH(DC)} = 1.1 \times V_{DDQ}$	0.8	1.0	1.1	$R_{ZQ}/7$	1, 2, 3
Mismatch between DQ to DQ within byte variation pull-up, $MM_{PUdd}$	$V_{OM(DC)} = 0.8 \times V_{DDQ}$	-10	-	10	%	1, 2, 3, 4, 5	
Mismatch between DQ to DQ within byte variation pull-down, $MM_{PDdd}$	$V_{OM(DC)} = 0.8 \times V_{DDQ}$	-	-	10	%	1, 2, 3, 4, 6, 7	
Mismatch between pull-up and pull-down, $MM_{PUPD}$	$V_{OM(DC)} = 0.8 \times V_{DDQ}$	-	-	10	%	1, 2, 3, 4, 6, 7	

- Notes:
- The tolerance limits are specified after calibration with stable voltage and temperature. For the behavior of the tolerance limits if temperature or voltage changes after calibration, see following section on voltage and temperature sensitivity.
  - The tolerance limits are specified under the condition that  $V_{DDQ} = V_{DD}$  and that  $V_{SSQ} = V_{SS}$ .
  - Micron recommends calibrating pull-down and pull-up output driver impedances at  $0.8 \times V_{DDQ}$ . Other calibration schemes may be used to achieve the linearity specification shown above; for example, calibration at  $0.5 \times V_{DDQ}$  and  $1.1 \times V_{DDQ}$ .
  - DQ-to-DQ mismatch within byte variation for a given component including  $DQS\_t$  and  $DQS\_c$  (characterized).
  - Measurement definition for mismatch between pull-up and pull-down,  $MM_{PUPD}$ : Measure both  $R_{ONPU}$  and  $R_{ONPD}$  at  $0.8 \times V_{DDQ}$  separately;  $R_{ON,nom}$  is the nominal  $R_{ON}$  value:

$$MM_{PUPD} = \frac{R_{ONPU} - R_{ONPD}}{R_{ON,nom}} \times 100$$

- $R_{ON}$  variance range ratio to  $R_{ON}$  nominal value in a given component, including  $DQS\_t$  and  $DQS\_c$ :

$$MM_{PUDD} = \frac{R_{ONPU,max} - R_{ONPU,min}}{R_{ON,nom}} \times 100$$

$$MM_{PDDD} = \frac{R_{ONPD,max} - R_{ONPD,min}}{R_{ON,nom}} \times 100$$

- The lower and upper bytes of a x16 are each treated on a per byte basis.
- For IT and AT devices, the minimum values are derated by 9% when the device operates between  $-40^{\circ}\text{C}$  and  $0^{\circ}\text{C}$  (TC).

**Table 115: Weak Mode (48Ω) Output Driver Electrical Characteristics**

Assumes  $R_{ZQ} = 240\Omega$ ; Entire operating temperature range after proper ZQ calibration

$R_{ON,nom}$	Resistor	$V_{OUT}$	Min	Nim	Max	Unit	Notes
48Ω	$R_{ON34PD}$	$V_{OL(DC)} = 0.5 \times V_{DDQ}$	0.8	1.0	1.1	$R_{ZQ}/5$	1, 2, 3
		$V_{OM(DC)} = 0.8 \times V_{DDQ}$	0.9	1.0	1.1	$R_{ZQ}/5$	1, 2, 3
		$V_{OH(DC)} = 1.1 \times V_{DDQ}$	0.9	1.0	1.25	$R_{ZQ}/5$	1, 2, 3
	$R_{ON34PU}$	$V_{OL(DC)} = 0.5 \times V_{DDQ}$	0.9	1.0	1.25	$R_{ZQ}/5$	1, 2, 3
		$V_{OM(DC)} = 0.8 \times V_{DDQ}$	0.9	1.0	1.1	$R_{ZQ}/5$	1, 2, 3
		$V_{OH(DC)} = 1.1 \times V_{DDQ}$	0.8	1.0	1.1	$R_{ZQ}/5$	1, 2, 3
Mismatch between DQ to DQ within byte variation pull-up, $MM_{PUdd}$		$V_{OM(DC)} = 0.8 \times V_{DDQ}$	-10	-	10	%	1, 2, 3, 4, 5
Mismatch between DQ to DQ within byte variation pull-down, $MM_{PDdd}$		$V_{OM(DC)} = 0.8 \times V_{DDQ}$	-	-	10	%	1, 2, 3, 4, 6, 7
Mismatch between pull-up and pull-down, $MM_{PUPD}$		$V_{OM(DC)} = 0.8 \times V_{DDQ}$	-	-	10	%	1, 2, 3, 4, 6, 7

- Notes:
- The tolerance limits are specified after calibration with stable voltage and temperature. For the behavior of the tolerance limits if temperature or voltage changes after calibration, see following section on voltage and temperature sensitivity.
  - The tolerance limits are specified under the condition that  $V_{DDQ} = V_{DD}$  and that  $V_{SSQ} = V_{SS}$ .
  - Micron recommends calibrating pull-down and pull-up output driver impedances at  $0.8 \times V_{DDQ}$ . Other calibration schemes may be used to achieve the linearity specification shown above; for example, calibration at  $0.5 \times V_{DDQ}$  and  $1.1 \times V_{DDQ}$ .
  - DQ-to-DQ mismatch within byte variation for a given component including  $DQS\_t$  and  $DQS\_c$  (characterized).
  - Measurement definition for mismatch between pull-up and pull-down,  $MM_{PUPD}$ : Measure both  $R_{ONPU}$  and  $R_{ONPD}$  at  $0.8 \times V_{DDQ}$  separately;  $R_{ON,nom}$  is the nominal  $R_{ON}$  value:

$$MM_{PUPD} = \frac{R_{ONPU} - R_{ONPD}}{R_{ON,nom}} \times 100$$

- $R_{ON}$  variance range ratio to  $R_{ON}$  nominal value in a given component, including  $DQS\_t$  and  $DQS\_c$ :

$$MM_{PUDD} = \frac{R_{ONPU,max} - R_{ONPU,min}}{R_{ON,nom}} \times 100$$

$$MM_{PDDD} = \frac{R_{ONPD,max} - R_{ONPD,min}}{R_{ON,nom}} \times 100$$

- The lower and upper bytes of a x16 are each treated on a per byte basis.
- For IT and AT devices, the minimum values are derated by 9% when the device operates between  $-40^{\circ}\text{C}$  and  $0^{\circ}\text{C}$  (TC).

### Output Driver Temperature and Voltage Sensitivity

If temperature and/or voltage change after calibration, the tolerance limits widen according to the equations and tables below.

$$\Delta T = T - T(@\text{calibration}); \Delta V = V_{DDQ} - V_{DDQ}(@ \text{calibration}); V_{DD} = V_{DDQ}$$

**Table 116: Output Driver Sensitivity Definitions**

Symbol	Min	Max	Unit
$R_{ONPU} @ V_{OH(DC)}$	$0.6 - dR_{ONdTH} \times  \Delta T  - dR_{ONdVH} \times  \Delta V $	$1.1 - dR_{ONdTH} \times  \Delta T  + dR_{ONdVH} \times  \Delta V $	$R_{ZQ}/6$
$R_{ON} @ V_{OM(DC)}$	$0.9 - dR_{ONdTM} \times  \Delta T  - dR_{ONdVM} \times  \Delta V $	$1.1 + dR_{ONdTM} \times  \Delta T  + dR_{ONdVM} \times  \Delta V $	$R_{ZQ}/6$
$R_{ONPD} @ V_{OL(DC)}$	$0.6 - dR_{ONdTL} \times  \Delta T  - dR_{ONdVL} \times  \Delta V $	$1.1 + dR_{ONdTL} \times  \Delta T  + dR_{ONdVL} \times  \Delta V $	$R_{ZQ}/6$

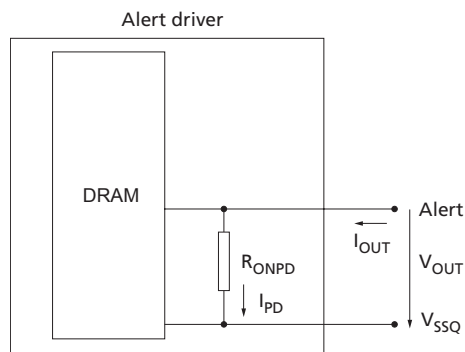
**Table 117: Output Driver Voltage and Temperature Sensitivity**

Symbol	Voltage and Temperature Range		Unit
	Min	Max	
$dR_{ONdTM}$	0	1.5	$\%/^{\circ}\text{C}$
$dR_{ONdVM}$	0	0.15	$\%/mV$
$dR_{ONdTL}$	0	1.5	$\%/^{\circ}\text{C}$
$dR_{ONdVL}$	0	0.15	$\%/mV$
$dR_{ONdTH}$	0	1.5	$\%/^{\circ}\text{C}$
$dR_{ONdVM}$	0	0.15	$\%/mV$

### Alert Driver

A functional representation of the alert output buffer is shown in the figure below. Output driver impedance,  $R_{ON}$ , is defined as follows.

**Figure 227: Alert Driver**



$R_{ONPD}$  when  $R_{ONPU}$  is off:

$$R_{ONPD} = \frac{V_{OUT}}{|I_{OUT}|}$$

**Table 118: Alert Driver Voltage**

R <sub>ON,nom</sub>	Register	V <sub>OUT</sub>	Min	Nom	Max	Unit
N/A	R <sub>ONPD</sub>	V <sub>OL(DC)</sub> = 0.1 × V <sub>DDQ</sub>	0.3	N/A	1.2	R <sub>ZQ</sub> /7
		V <sub>OM(DC)</sub> = 0.8 × V <sub>DDQ</sub>	0.4	N/A	1.12	R <sub>ZQ</sub> /7
		V <sub>OH(DC)</sub> = 1.1 × V <sub>DDQ</sub>	0.4	N/A	1.4	R <sub>ZQ</sub> /7

Note: 1. V<sub>DDQ</sub> voltage is at V<sub>DDQ(DC)</sub>.

## Electrical Characteristics – On-Die Termination Characteristics

### ODT Levels and I-V Characteristics

On-die termination (ODT) effective resistance settings are defined and can be selected by any or all of the following options:

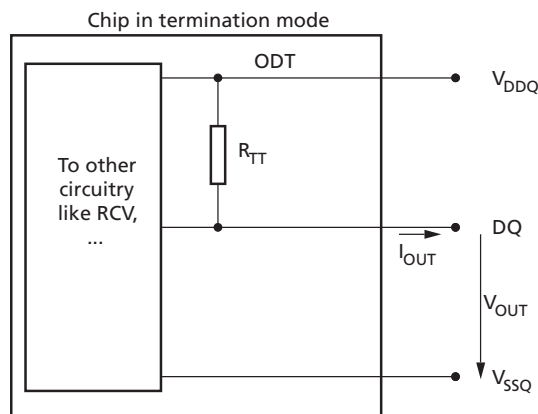
- MR1[10:8] (R<sub>TT(NOM)</sub>): Disable, 240 ohms, 120 ohms, 80 ohms, 60 ohms, 48 ohms, 40 ohms, and 34 ohms.
- MR2[11:9] (R<sub>TT(WR)</sub>): Disable, 240 ohms, 120 ohms, and 80 ohms.
- MR5[8:6] (R<sub>TT(Park)</sub>): Disable, 240 ohms, 120 ohms, 80 ohms, 60 ohms, 48 ohms, 40 ohms, and 34 ohms.

ODT is applied to the following inputs:

- x4: DQ, DM<sub>n</sub>, DQS<sub>t</sub>, and DQS<sub>c</sub> inputs.
- x8: DQ, DM<sub>n</sub>, DQS<sub>t</sub>, DQS<sub>c</sub>, TDQS<sub>t</sub>, and TDQS<sub>c</sub> inputs.
- x16: DQ, LDM<sub>n</sub>, UDM<sub>n</sub>, LDQS<sub>t</sub>, LDQS<sub>c</sub>, UDQS<sub>t</sub>, and UDQS<sub>c</sub> inputs.

A functional representation of ODT is shown in the figure below.

**Figure 228: ODT Definition of Voltages and Currents**



**Table 119: ODT DC Characteristics**

$R_{TT}$	$V_{OUT}$	Min	Nom	Max	Unit	Notes
240 ohm	$V_{OL(DC)} = 0.5 \times V_{DDQ}$	0.9	1	1.25	$R_{ZQ}$	1, 2, 3
	$V_{OM(DC)} = 0.8 \times V_{DDQ}$	0.9	1	1.1	$R_{ZQ}$	1, 2, 3
	$V_{OH(DC)} = 1.1 \times V_{DDQ}$	0.8	1	1.1	$R_{ZQ}$	1, 2, 3
120 ohm	$V_{OL(DC)} = 0.5 \times V_{DDQ}$	0.9	1	1.25	$R_{ZQ}/2$	1, 2, 3
	$V_{OM(DC)} = 0.8 \times V_{DDQ}$	0.9	1	1.1	$R_{ZQ}/2$	1, 2, 3
	$V_{OH(DC)} = 1.1 \times V_{DDQ}$	0.8	1	1.1	$R_{ZQ}/2$	1, 2, 3
80 ohm	$V_{OL(DC)} = 0.5 \times V_{DDQ}$	0.9	1	1.25	$R_{ZQ}/3$	1, 2, 3
	$V_{OM(DC)} = 0.8 \times V_{DDQ}$	0.9	1	1.1	$R_{ZQ}/3$	1, 2, 3
	$V_{OH(DC)} = 1.1 \times V_{DDQ}$	0.8	1	1.1	$R_{ZQ}/3$	1, 2, 3
60 ohm	$V_{OL(DC)} = 0.5 \times V_{DDQ}$	0.9	1	1.25	$R_{ZQ}/4$	1, 2, 3
	$V_{OM(DC)} = 0.8 \times V_{DDQ}$	0.9	1	1.1	$R_{ZQ}/4$	1, 2, 3
	$V_{OH(DC)} = 1.1 \times V_{DDQ}$	0.8	1	1.1	$R_{ZQ}/4$	1, 2, 3
48 ohm	$V_{OL(DC)} = 0.5 \times V_{DDQ}$	0.9	1	1.25	$R_{ZQ}/5$	1, 2, 3
	$V_{OM(DC)} = 0.8 \times V_{DDQ}$	0.9	1	1.1	$R_{ZQ}/5$	1, 2, 3
	$V_{OH(DC)} = 1.1 \times V_{DDQ}$	0.8	1	1.1	$R_{ZQ}/5$	1, 2, 3
40 ohm	$V_{OL(DC)} = 0.5 \times V_{DDQ}$	0.9	1	1.25	$R_{ZQ}/6$	1, 2, 3
	$V_{OM(DC)} = 0.8 \times V_{DDQ}$	0.9	1	1.1	$R_{ZQ}/6$	1, 2, 3
	$V_{OH(DC)} = 1.1 \times V_{DDQ}$	0.8	1	1.1	$R_{ZQ}/6$	1, 2, 3
34 ohm	$V_{OL(DC)} = 0.5 \times V_{DDQ}$	0.9	1	1.25	$R_{ZQ}/7$	1, 2, 3
	$V_{OM(DC)} = 0.8 \times V_{DDQ}$	0.9	1	1.1	$R_{ZQ}/7$	1, 2, 3
	$V_{OH(DC)} = 1.1 \times V_{DDQ}$	0.8	1	1.1	$R_{ZQ}/7$	1, 2, 3
DQ-to-DQ mismatch within byte	$V_{OM(DC)} = 0.8 \times V_{DDQ}$	0	–	10	%	1, 2, 4, 5, 6

- Notes:
1. The tolerance limits are specified after calibration to 240 ohm  $\pm 1\%$  resistor with stable voltage and temperature. For the behavior of the tolerance limits if temperature or voltage changes after calibration, see ODT Temperature and Voltage Sensitivity.
  2. Micron recommends calibrating pull-up ODT resistors at  $0.8 \times V_{DDQ}$ . Other calibration schemes may be used to achieve the linearity specification shown here.
  3. The tolerance limits are specified under the condition that  $V_{DDQ} = V_{DD}$  and  $V_{SSQ} = V_{SS}$ .
  4. The DQ-to-DQ mismatch within byte variation for a given component including DQS<sub>t</sub> and DQS<sub>c</sub>.
  5.  $R_{TT}$  variance range ratio to  $R_{TT}$  nominal value in a given component, including DQS<sub>t</sub> and DQS<sub>c</sub>.

$$\text{DQ-to-DQ mismatch} = \frac{R_{TT(\text{MAX})} - R_{TT(\text{MIN})}}{R_{TT(\text{NOM})}} \times 100$$

6. DQ-to-DQ mismatch for a x16 device is treated as two separate bytes.
7. For IT and AT devices, the minimum values are derated by 9% when the device operates between  $-40^{\circ}\text{C}$  and  $0^{\circ}\text{C}$  (TC).

### ODT Temperature and Voltage Sensitivity

If temperature and/or voltage change after calibration, the tolerance limits widen according to the following equations and tables.

$$\Delta T = T - T(@ \text{ calibration}); \Delta V = V_{DDQ} - V_{DDQ}(@ \text{ calibration}); V_{DD} = V_{DDQ}$$

**Table 120: ODT Sensitivity Definitions**

Parameter	Min	Max	Unit
$R_{TT@}$	$0.9 - dR_{TTdT} \times  \Delta T  - dR_{TTdV} \times  \Delta V $	$1.6 + dR_{TTdTH} \times  \Delta T  + dR_{TTdVH} \times  \Delta V $	$R_{ZQ}/n$

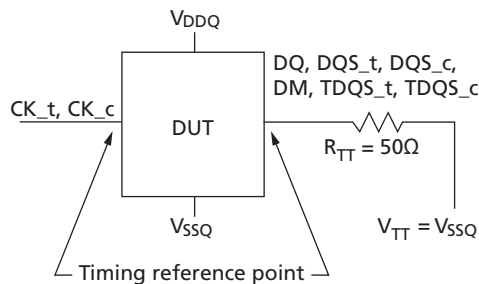
**Table 121: ODT Voltage and Temperature Sensitivity**

Parameter	Min	Max	Unit
$dR_{TTdT}$	0	1.5	%/°C
$dR_{TTdV}$	0	0.15	%/mV

### ODT Timing Definitions

The reference load for ODT timings is different than the reference load used for timing measurements.

**Figure 229: ODT Timing Reference Load**



### ODT Timing Definitions and Waveforms

Definitions for  $t_{ADC}$ ,  $t_{AONAS}$ , and  $t_{AOFAS}$  are provided in the Table 122 (page 292) and shown in Figure 230 (page 293) and Figure 232 (page 294). Measurement reference settings are provided in the subsequent Table 123 (page 292).

The  $t_{ADC}$  for the dynamic ODT case and read disable ODT cases are represented by  $t_{ADC}$  of Direct ODT Control case.

**Table 122: ODT Timing Definitions**

Parameter	Begin Point Definition	End Point Definition	Figure
<sup>t</sup> ADC	Rising edge of CK_t, CK_c defined by the end point of DODTLoFF	Extrapolated point at $V_{RTT,nom}$	Figure 230 (page 293)
	Rising edge of CK_t, CK_c defined by the end point of DODTLon	Extrapolated point at $V_{SSQ}$	Figure 230 (page 293)
	Rising edge of CK_t, CK_c defined by the end point of ODTLcnw	Extrapolated point at $V_{RTT,nom}$	Figure 231 (page 293)
	Rising edge of CK_t, CK_c defined by the end point of ODTLcwn4 or ODTLcwn8	Extrapolated point at $V_{SSQ}$	Figure 231 (page 293)
<sup>t</sup> AONAS	Rising edge of CK_t, CK_c with ODT being first registered HIGH	Extrapolated point at $V_{SSQ}$	Figure 232 (page 294)
<sup>t</sup> AOFAS	Rising edge of CK_t, CK_c with ODT being first registered LOW	Extrapolated point at $V_{RTT,nom}$	Figure 232 (page 294)

**Table 123: Reference Settings for ODT Timing Measurements**

Measure Parameter	$R_{TT(Park)}$	$R_{TT(NOM)}$	$R_{TT(WR)}$	VSW1	VSW2	Note
<sup>t</sup> ADC	Disable	$R_{ZQ}/7$ (34Ω)	–	0.20V	0.40V	1, 2, 4
	–	$R_{ZQ}/7$ (34Ω)	High-Z	0.20V	0.40V	1, 3, 5
<sup>t</sup> AONAS	Disable	$R_{ZQ}/7$ (34Ω)	–	0.20V	0.40V	1, 2, 6
<sup>t</sup> AOFAS	Disable	$R_{ZQ}/7$ (34Ω)	–	0.20V	0.40V	1, 2, 6

- Notes:
1. MR settings are as follows: MR1 has A10 = 1, A9 = 1, A8 = 1 for  $R_{TT(NOM)}$  setting; MR5 has A8 = 0, A7 = 0, A6 = 0 for  $R_{TT(Park)}$  setting; and MR2 has A11 = 0, A10 = 1, A9 = 1 for  $R_{TT(WR)}$  setting.
  2. ODT state change is controlled by ODT pin.
  3. ODT state change is controlled by a WRITE command.
  4. Refer to Figure 230 (page 293).
  5. Refer to Figure 231 (page 293).
  6. Refer to Figure 232 (page 294).

Figure 230:  $t_{ADC}$  Definition with Direct ODT Control

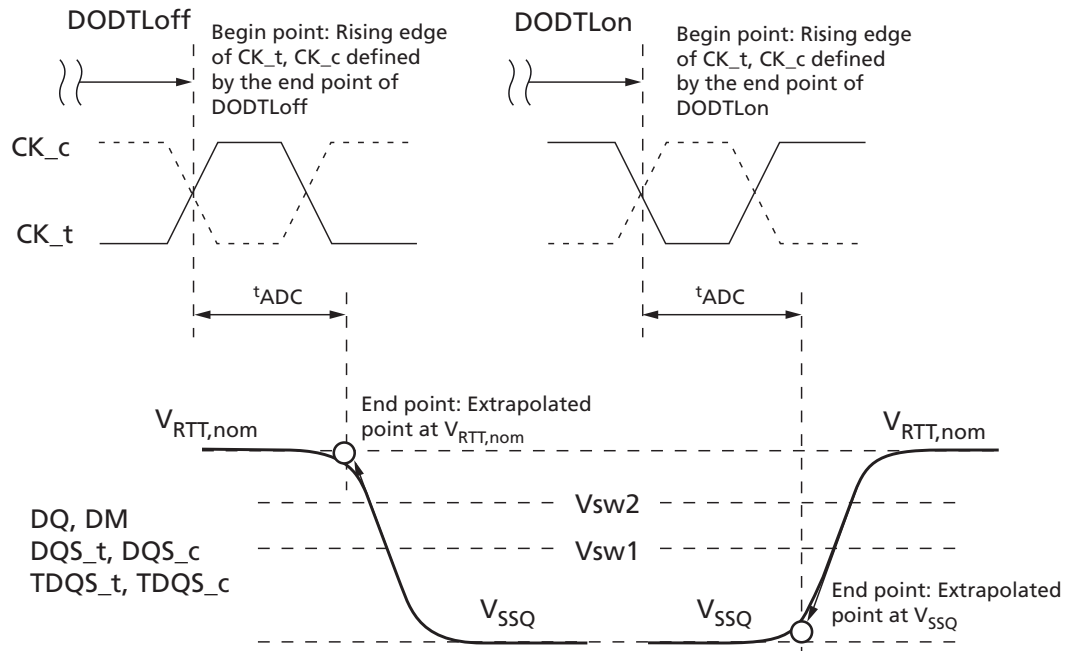


Figure 231:  $t_{ADC}$  Definition with Dynamic ODT Control

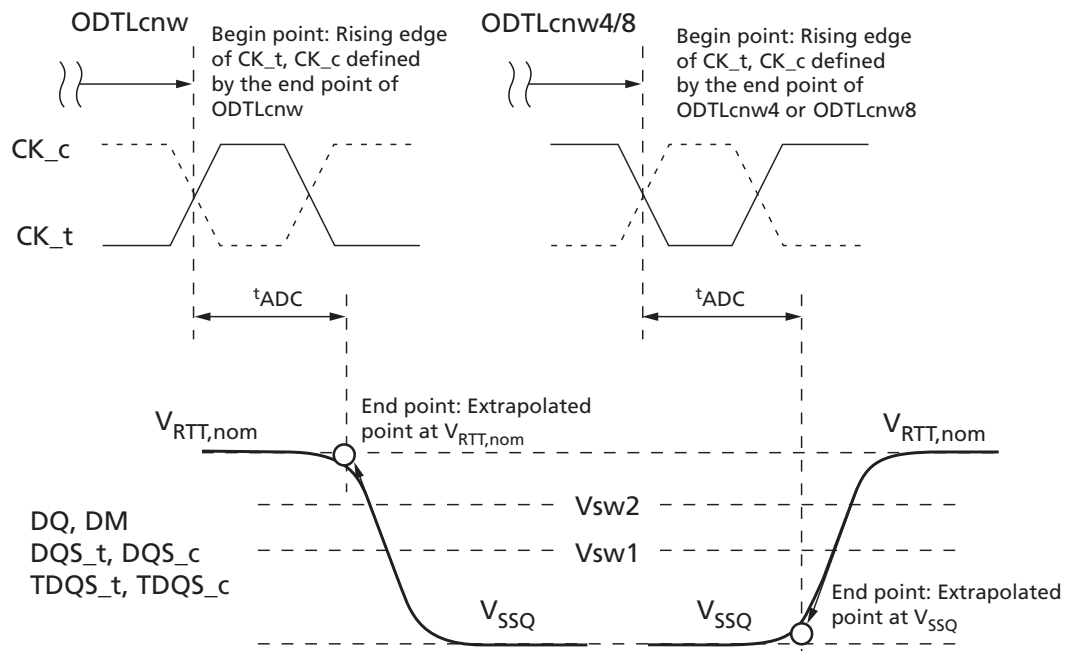
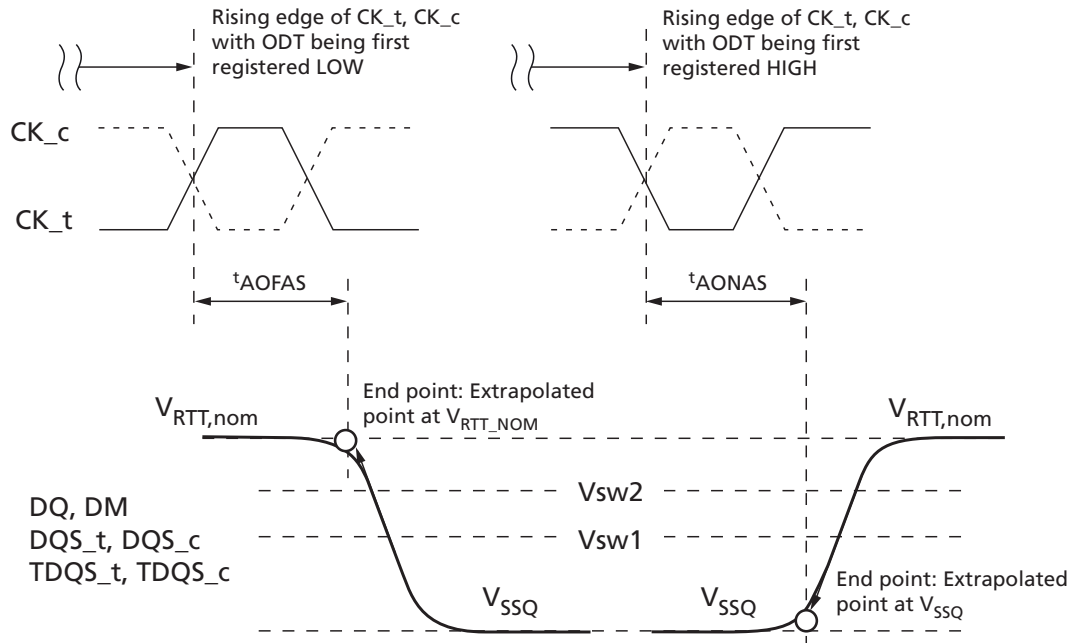


Figure 232:  $t_{AOFAS}$  and  $t_{AONAS}$  Definitions



## DRAM Package Electrical Specifications

**Table 124: DRAM Package Electrical Specifications for x4 and x8 Devices**

Parameter		Symbol	1600, 1866		2133, 2400		2666, 3200		Unit	Notes
			Min	Max	Min	Max	Min	Max		
Input/output	Zpkg	$Z_{IO}$	45	85	45	85	TBD	TBD	ohm	1, 2, 4
	Package delay	$Td_{IO}$	14	42	14	42	TBD	TBD	ps	1, 3, 4
	Lpkg	$L_{IO}$	–	3.3	–	3.3	TBD	TBD	nH	
	Cpkg	$C_{IO}$	–	0.78	–	0.78	TBD	TBD	pF	
DQS_t, DQS_c	Zpkg	$Z_{IO\ DQS}$	45	85	45	85	TBD	TBD	ohm	1, 2
	Package delay	$Td_{IO\ DQS}$	14	42	14	42	TBD	TBD	ps	1, 3
	Delta Zpkg	$DZ_{IO\ DQS}$	–	10	–	10	TBD	TBD	ohm	1, 2, 6
	Delta delay	$DTd_{IO\ DQS}$	–	5	–	5	TBD	TBD	ps	1, 3, 6
	Lpkg	$L_{IO\ DQS}$	–	3.3	–	3.3	TBD	TBD	nH	
	Cpkg	$C_{IO\ DQS}$	–	0.78	–	0.78	TBD	TBD	pF	
Input CTRL pins	Zpkg	$Z_{I\ CTRL}$	50	90	50	90	TBD	TBD	ohm	1, 2, 8
	Package delay	$Td_{I\ CTRL}$	14	42	14	42	TBD	TBD	ps	1, 3, 8
	Lpkg	$L_{I\ CTRL}$	–	3.4	–	3.4	TBD	TBD	nH	
	Cpkg	$C_{I\ CTRL}$	–	0.7	–	0.7	TBD	TBD	pF	
Input CMD ADD pins	Zpkg	$Z_{I\ ADD\ CMD}$	50	90	50	90	TBD	TBD	ohm	1, 2, 7
	Package delay	$Td_{I\ ADD\ CMD}$	14	45	14	45	TBD	TBD	ps	1, 3, 7
	Lpkg	$L_{I\ ADD\ CMD}$	–	3.6	–	3.6	TBD	TBD	nH	
	Cpkg	$C_{I\ ADD\ CMD}$	–	0.74	–	0.74	TBD	TBD	pF	
CK_t, CK_c	Zpkg	$Z_{CK}$	50	90	50	90	TBD	TBD	ohm	1, 2
	Package delay	$Td_{CK}$	14	42	14	42	TBD	TBD	ps	1, 3
	Delta Zpkg	$DZ_{DCK}$	–	10	–	10	TBD	TBD	ohm	1, 2, 5
	Delta delay	$DTd_{DCK}$	–	5	–	5	TBD	TBD	ps	1, 3, 5
	Lpkg	$L_{I\ CLK}$	–	3.4	–	3.4	TBD	TBD	nH	
	Cpkg	$C_{I\ CLK}$	–	0.7	–	0.7	TBD	TBD	pF	
ZQ Zpkg	$Z_{O\ ZQ}$	40	100	40	100	TBD	TBD	ohm	1, 2	
ZQ delay	$Td_{O\ ZQ}$	20	55	20	55	TBD	TBD	ps	1, 3	
ALERT Zpkg	$Z_{O\ ALERT}$	40	100	40	100	TBD	TBD	ohm	1, 2	
ALERT delay	$Td_{O\ ALERT}$	20	55	20	55	TBD	TBD	ps	1, 3	

- Notes:
1. The package parasitic (L and C) are validated using package only samples. The capacitance is measured with  $V_{DD}$ ,  $V_{DDQ}$ ,  $V_{SS}$ , and  $V_{SSQ}$  shorted with all other signal pins floating. The inductance is measured with  $V_{DD}$ ,  $V_{DDQ}$ ,  $V_{SS}$ , and  $V_{SSQ}$  shorted and all other signal pins shorted at the die, not pin, side.
  2. Package-only impedance (Zpkg) is calculated based on the Lpkg and Cpkg total for a given pin where: Zpkg (total per pin) =  $\sqrt{Lpkg/Cpkg}$ .
  3. Package-only delay (Tpkg) is calculated based on Lpkg and Cpkg total for a given pin where: Tdpkg (total per pin) =  $\sqrt{Lpkg \times Cpkg}$ .
  4.  $Z_{IO}$  and  $Td_{IO}$  apply to DQ, DM, DQS\_c, DQS\_t, TDQS\_t, and TDQS\_c.



## 4Gb: x4, x8, x16 DDR4 SDRAM DRAM Package Electrical Specifications

5. Absolute value of ZCK\_t, ZCK\_c for impedance (Z) or absolute value of TdCK\_t, TdCK\_c for delay (Td).
6. Absolute value of ZIO (DQS\_t), ZIO (DQS\_c) for impedance (Z) or absolute value of TdIO (DQS\_t), TdIO (DQS\_c) for delay (Td).
7. Z<sub>I ADD CMD</sub> and Td<sub>I ADD CMD</sub> apply to A[17:0], BA[1:0], BG[1:0], RAS\_n CAS\_n, and WE\_n.
8. Z<sub>I CTRL</sub> and Td<sub>I CTRL</sub> apply to ODT, CS\_n, and CKE.
9. Package implementations will meet specification if the Zpkg and package delay fall within the ranges shown, and the maximum Lpkg and Cpkg do not exceed the maximum values shown.
10. It is assumed that Lpkg can be approximated as  $L_{pkg} = Z_O \times Td$ .
11. It is assumed that Cpkg can be approximated as  $C_{pkg} = Td/Z_O$ .

**Table 125: DRAM Package Electrical Specifications for x16 Devices**

Parameter		Symbol	1600, 1866		2133, 2400		2666, 3200		Unit	Notes
			Min	Max	Min	Max	Min	Max		
Input/ output	Zpkg	Z <sub>IO</sub>	45	85	45	85	TBD	TBD	ohm	1, 2, 4
	Package delay	Td <sub>IO</sub>	14	45	14	45	TBD	TBD	ps	1, 3, 4
	Lpkg	L <sub>IO</sub>	–	3.4	–	3.4	TBD	TBD	nH	
	Cpkg	C <sub>IO</sub>	–	0.82	–	0.82	TBD	TBD	pF	
DQSL_t/ DQSL_c/ DQSU_t/ DQSU_c	Zpkg	Z <sub>IO DQS</sub>	45	85	45	85	TBD	TBD	ohm	1, 2
	Package delay	Td <sub>IO DQS</sub>	14	45	14	45	TBD	TBD	ps	1, 3
	Lpkg	L <sub>IO DQS</sub>	–	3.4	–	3.4	TBD	TBD	nH	
	Cpkg	C <sub>IO DQS</sub>	–	0.82	–	0.82	TBD	TBD	pF	
DQSL_t/ DQSL_c, DQSU_t/ DQSU_c,	Delta Zpkg	DZ <sub>IO DQS</sub>	–	10	–	10	TBD	TBD	ohm	1, 2, 6
	Delta delay	DTd <sub>IO DQS</sub>	–	5	–	5	TBD	TBD	ps	1, 3, 6
Input CTRL pins	Zpkg	Z <sub>I CTRL</sub>	50	90	50	90	TBD	TBD	ohm	1, 2, 8
	Package delay	Td <sub>I CTRL</sub>	14	42	14	42	TBD	TBD	ps	1, 3, 8
	Lpkg	L <sub>I CTRL</sub>	–	3.4	–	3.4	TBD	TBD	nH	
	Cpkg	C <sub>I CTRL</sub>	–	0.7	–	0.7	TBD	TBD	pF	
Input CMD ADD pins	Zpkg	Z <sub>I ADD CMD</sub>	50	90	50	90	TBD	TBD	ohm	1, 2, 7
	Package delay	Td <sub>I ADD CMD</sub>	14	52	14	52	TBD	TBD	ps	1, 3, 7
	Lpkg	L <sub>I ADD CMD</sub>	–	3.9	–	3.9	TBD	TBD	nH	
	Cpkg	C <sub>I ADD CMD</sub>	–	0.86	–	0.86	TBD	TBD	pF	
CK_t, CK_c	Zpkg	Z <sub>CK</sub>	50	90	50	90	TBD	TBD	ohm	1, 2
	Package delay	Td <sub>CK</sub>	14	42	14	42	TBD	TBD	ps	1, 3
	Delta Zpkg	DZ <sub>DCK</sub>	–	10	–	10	TBD	TBD	ohm	1, 2, 5
	Delta delay	DTd <sub>DCK</sub>	–	5	–	5	TBD	TBD	ps	1, 3, 5
Input CLK	Lpkg	L <sub>I CLK</sub>	–	3.4	–	3.4	TBD	TBD	nH	
	Cpkg	C <sub>I CLK</sub>	–	0.7	–	0.7	TBD	TBD	pF	
ZQ Zpkg	Z <sub>O ZQ</sub>	40	100	40	100	TBD	TBD	ohm	1, 2	
ZQ delay	Td <sub>O ZQ</sub>	20	90	20	90	TBD	TBD	ps	1, 3	
ALERT Zpkg	Z <sub>O ALERT</sub>	40	100	40	100	TBD	TBD	ohm	1, 2	

**Table 125: DRAM Package Electrical Specifications for x16 Devices (Continued)**

Parameter	Symbol	1600, 1866		2133, 2400		2666, 3200		Unit	Notes
		Min	Max	Min	Max	Min	Max		
ALERT delay	Td <sub>O ALERT</sub>	20	55	20	55	TBD	TBD	ps	1, 3

- Notes:
1. The package parasitic (L and C) are validated using package only samples. The capacitance is measured with V<sub>DD</sub>, V<sub>DDQ</sub>, V<sub>SS</sub>, and V<sub>SSQ</sub> shorted with all other signal pins floating. The inductance is measured with V<sub>DD</sub>, V<sub>DDQ</sub>, V<sub>SS</sub>, and V<sub>SSQ</sub> shorted and all other signal pins shorted at the die, not pin, side.
  2. Package-only impedance (Z<sub>pkg</sub>) is calculated based on the L<sub>pkg</sub> and C<sub>pkg</sub> total for a given pin where: Z<sub>pkg</sub> (total per pin) = SQRT (L<sub>pkg</sub>/C<sub>pkg</sub>).
  3. Package-only delay (T<sub>pkg</sub>) is calculated based on L<sub>pkg</sub> and C<sub>pkg</sub> total for a given pin where: T<sub>pkg</sub> (total per pin) = SQRT (L<sub>pkg</sub> × C<sub>pkg</sub>).
  4. Z<sub>IO</sub> and Td<sub>IO</sub> apply to DQ, DM, DQS<sub>c</sub>, DQS<sub>t</sub>, TDQS<sub>t</sub>, and TDQS<sub>c</sub>.
  5. Absolute value of ZCK<sub>t</sub>, ZCK<sub>c</sub> for impedance (Z) or absolute value of TdCK<sub>t</sub>, TdCK<sub>c</sub> for delay (Td).
  6. Absolute value of ZIO (DQS<sub>t</sub>), ZIO (DQS<sub>c</sub>) for impedance (Z) or absolute value of TdIO (DQS<sub>t</sub>), TdIO (DQS<sub>c</sub>) for delay (Td).
  7. Z<sub>I ADD CMD</sub> and Td<sub>I ADD CMD</sub> apply to A[17:0], BA[1:0], BG[1:0], RAS<sub>n</sub> CAS<sub>n</sub>, and WE<sub>n</sub>.
  8. Z<sub>I CTRL</sub> and Td<sub>I CTRL</sub> apply to ODT, CS<sub>n</sub>, and CKE.
  9. Package implementations will meet specification if the Z<sub>pkg</sub> and package delay fall within the ranges shown, and the maximum L<sub>pkg</sub> and C<sub>pkg</sub> do not exceed the maximum values shown.
  10. It is assumed that L<sub>pkg</sub> can be approximated as L<sub>pkg</sub> = Z<sub>O</sub> × Td.
  11. It is assumed that C<sub>pkg</sub> can be approximated as C<sub>pkg</sub> = Td/Z<sub>O</sub>.

**Table 126: Pad Input/Output Capacitance**

Parameter	Symbol	DDR4-1600, 1866, 2133		DDR4-2400, 2666		DDR4-3200		Unit	Notes
		Min	Max	Min	Max	Min	Max		
Input/output capacitance: DQ, DM, DQS_t, DQS_c, TDQS_t, TDQS_c	C <sub>IO</sub>	0.55	1.4	0.55	1.15	0.55	1.15	pF	1, 2, 3
Input capacitance: CK_t and CK_c	C <sub>CK</sub>	0.2	0.8	0.2	0.7	0.2	0.7	pF	1, 2, 3, 4
Input capacitance delta: CK_t and CK_c	C <sub>DCK</sub>	0	0.05	0	0.05	0	0.05	pF	1, 2, 3, 5
Input/output capacitance delta: DQS_t and DQS_c	C <sub>DDQS</sub>	0	0.05	0	0.05	0	0.05	pF	1, 3
Input capacitance: CTRL, ADD, CMD input-only pins	C <sub>I</sub>	0.2	0.8	0.2	0.7	0.2	0.7	pF	1, 3, 6
Input capacitance delta: All CTRL input-only pins	C <sub>DI_CTRL</sub>	-0.1	0.1	-0.1	0.1	-0.1	0.1	pF	1, 3, 7
Input capacitance delta: All ADD/CMD input-only pins	C <sub>DI_ADD_CMD</sub>	-0.1	0.1	-0.1	0.1	-0.1	0.1	pF	1, 3, 8, 9
Input/output capacitance delta: DQ, DM, DQS_t, DQS_c, TDQS_t, TDQS_c	C <sub>DIO</sub>	-0.1	0.1	-0.1	0.1	-0.1	0.1	pF	1, 2, 10, 11
Input/output capacitance: ALERT pin	C <sub>ALERT</sub>	0.5	1.5	0.5	1.5	0.5	1.5	pF	1, 3
Input/output capacitance: ZQ pin	C <sub>ZQ</sub>	0.5	2.3	0.5	2.3	0.5	2.3	pF	1, 3, 12
Input/output capacitance: TEN pin	C <sub>TEN</sub>	0.2	2.3	0.2	2.3	0.2	2.3	pF	1, 3, 13

- Notes:
1. Although the DM, TDQS\_t, and TDQS\_c pins have different functions, the loading matches DQ and DQS.
  2. This parameter is not subject to a production test; it is verified by design and characterization. The capacitance is measured according to the JEP147 specification, "Procedure for Measuring Input Capacitance Using a Vector Network Analyzer (VNA)," with V<sub>DD</sub>, V<sub>DDQ</sub>, V<sub>SS</sub>, and V<sub>SSQ</sub> applied and all other pins floating (except the pin under test, CKE, RESET\_n and ODT, as necessary). V<sub>DD</sub> = V<sub>DDQ</sub> = 1.5V, V<sub>BIAS</sub> = V<sub>DD</sub>/2 and on-die termination off.
  3. This parameter applies to monolithic die, obtained by de-embedding the package L and C parasitics.
  4. C<sub>DIO</sub> = C<sub>IO</sub>(DQ, DM) - 0.5 × (C<sub>IO</sub>(DQS\_t) + C<sub>IO</sub>(DQS\_c)).
  5. Absolute value of C<sub>IO</sub> (DQS\_t), C<sub>IO</sub> (DQS\_c)
  6. Absolute value of CCK\_t, CCK\_c
  7. C<sub>I</sub> applies to ODT, CS\_n, CKE, A[15:0], BA[1:0], RAS\_n, CAS\_n, and WE\_n.
  8. C<sub>DI\_CTRL</sub> applies to ODT, CS\_n, and CKE.
  9. C<sub>DI\_CTRL</sub> = C<sub>I</sub>(CTRL) - 0.5 × (C<sub>I</sub>(CLK\_t) + C<sub>I</sub>(CLK\_c)).
  10. C<sub>DI\_ADD\_CMD</sub> applies to A[15:0], BA[1:0], RAS\_n, CAS\_n and WE\_n.
  11. C<sub>DI\_ADD\_CMD</sub> = C<sub>I</sub>(ADD\_CMD) - 0.5 × (C<sub>I</sub>(CLK\_t) + C<sub>I</sub>(CLK\_c)).

- 12. Maximum external load capacitance on ZQ pin: 5pF.
- 13. Only applicable if TEN pin does not have an internal pull-up.

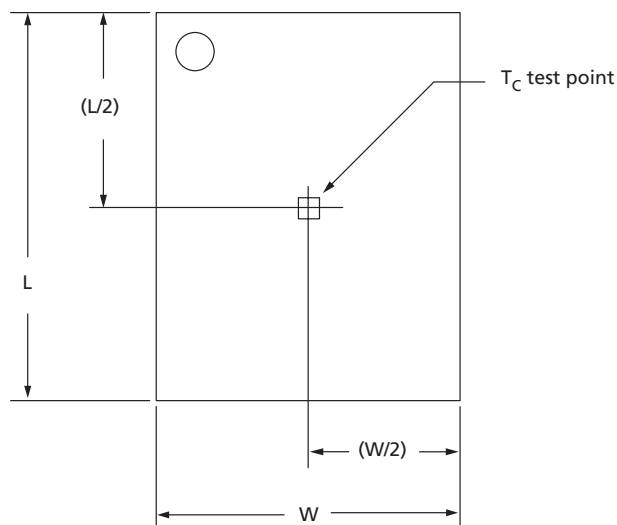
## Thermal Characteristics

**Table 127: Thermal Characteristics**

Parameter/Condition		Value	Units	Symbol	Notes
Operating case temperature: Commercial		0 to 85	°C	$T_C$	1, 2, 3
		0 to 95	°C	$T_C$	1, 2, 3, 4
Operating case temperature: Industrial		-40 to 85	°C	$T_C$	1, 2, 3
		-40 to 95	°C	$T_C$	1, 2, 3, 4
Operating case temperature: Automotive		-40 to 85	°C	$T_C$	1, 2, 3
		-40 to 105	°C	$T_C$	1, 2, 3, 4
Junction-to-case (TOP) Die Rev A	78-ball "HX"	4.4	°C/W	$\Theta_{JC}$	5
	96-ball "HA"	3.6			
Junction-to-case (TOP) Die Rev B	78-ball "RH"	TBD	°C/W	$\Theta_{JC}$	5
	96-ball "GE"	TBD			

- Notes:
- 1. MAX operating case temperature.  $T_C$  is measured in the center of the package.
  - 2. A thermal solution must be designed to ensure the DRAM device does not exceed the maximum  $T_C$  during operation.
  - 3. Device functionality is not guaranteed if the DRAM device exceeds the maximum  $T_C$  during operation.
  - 4. If  $T_C$  exceeds 85°C, the DRAM must be refreshed externally at 2x refresh, which is a 3.9µs interval refresh rate.
  - 5. The thermal resistance data is based off of a number of samples from multiple lots and should be viewed as a typical number.

**Figure 233: Thermal Measurement Point**



## Current Specifications – Measurement Conditions

### $I_{DD}$ , $I_{PP}$ , and $I_{DDQ}$ Measurement Conditions

$I_{DD}$ ,  $I_{PP}$ , and  $I_{DDQ}$  measurement conditions, such as test load and patterns, are defined in this section.

- $I_{DD}$  currents ( $I_{DD0}$ ,  $I_{DD1}$ ,  $I_{DD2N}$ ,  $I_{DD2NT}$ ,  $I_{DD2P}$ ,  $I_{DD2Q}$ ,  $I_{DD3N}$ ,  $I_{DD3P}$ ,  $I_{DD4R}$ ,  $I_{DD4W}$ ,  $I_{DD5B}$ ,  $I_{DD6N}$ ,  $I_{DD6E}$ ,  $I_{DD6R}$ ,  $I_{DD7}$ , and  $I_{DD8}$ ) are measured as time-averaged currents with all  $V_{DD}$  balls of the device under test grouped together.  $I_{PP}$  and  $I_{DDQ}$  currents are not included in  $I_{DD}$  currents.
- $I_{PP}$  currents are  $I_{PPSB}$  for standby cases ( $I_{DD2N}$ ,  $I_{DD2NT}$ ,  $I_{DD2P}$ ,  $I_{DD2Q}$ ,  $I_{DD3N}$ ,  $I_{DD3P}$ ,  $I_{DD8}$ );  $I_{PP0}$  for active cases ( $I_{DD0}$ ,  $I_{DD1}$ ,  $I_{DD4R}$ ,  $I_{DD4W}$ );  $I_{PP5B}$  and  $I_{PP6N}$  for self refresh cases ( $I_{DD6N}$ ,  $I_{DD6E}$ ,  $I_{DD6R}$ ), and  $I_{PP7}$ . These have the same definitions as the  $I_{DD}$  currents referenced but are measured on the  $V_{PP}$  supply.
- $I_{DDQ}$  currents ( $I_{DDQ2NT}$  and  $I_{DDQ4R}$ ) are measured as time-averaged currents with  $V_{DDQ}$  balls of the device under test grouped together.  $I_{DD}$  current is not included in  $I_{DDQ}$  currents.

**Note:**  $I_{DDQ}$  values cannot be directly used to calculate the I/O power of the device. They can be used to support correlation of simulated I/O power to actual I/O power. In DRAM module application,  $I_{DDQ}$  cannot be measured separately because  $V_{DD}$  and  $V_{DDQ}$  are using a merged-power layer in the module PCB.

The following definitions apply for  $I_{DD}$ ,  $I_{DDP}$  and  $I_{DDQ}$  measurements.

- “0” and “LOW” are defined as  $V_{IN} \leq V_{IL(AC)max}$
- “1” and “HIGH” are defined as  $V_{IN} \geq V_{IH(AC)min}$
- “Midlevel” is defined as inputs  $V_{REF} = V_{DD}/2$
- Timings used for  $I_{DD}$ ,  $I_{DDP}$  and  $I_{DDQ}$  measurement-loop patterns are provided in the Current Test Definition and Patterns section.
- Basic  $I_{DD}$ ,  $I_{PP}$ , and  $I_{DDQ}$  measurement conditions are described in the Current Test Definition and Patterns section.
- Detailed  $I_{DD}$ ,  $I_{PP}$ , and  $I_{DDQ}$  measurement-loop patterns are described in the Current Test Definition and Patterns section.
- Current measurements are done after properly initializing the device. This includes, but is not limited to, setting:
  - $R_{ON} = R_{ZQ}/7$  (34 ohm in MR1);
  - Qoff = 0B (output buffer enabled in MR1);
  - $R_{TT(NOM)} = R_{ZQ}/6$  (40 ohm in MR1);
  - $R_{TT(WR)} = R_{ZQ}/2$  (120 ohm in MR2);
  - $R_{TT(Park)}$  = disabled;
  - TDQS feature disabled in MR1; CRC disabled in MR2; CA parity feature disabled in MR3; Gear-down mode disabled in MR3; Read/Write DBI disabled in MR5; DM disabled in MR5
- Define D = {CS\_n, RAS\_n, CAS\_n, WE\_n}: = {HIGH, LOW, LOW, LOW}; apply BG/BA changes when directed.
- Define D\_n = {CS\_n, RAS\_n, CAS\_n, WE\_n}: = {HIGH, HIGH, HIGH, HIGH}; apply invert of BG/BA changes when directed above.

**Note:** The measurement-loop patterns must be executed at least once before actual current measurements can be taken.

Figure 234: Measurement Setup and Test Load for  $I_{DDx}$ ,  $I_{DDPx}$ , and  $I_{DDQx}$

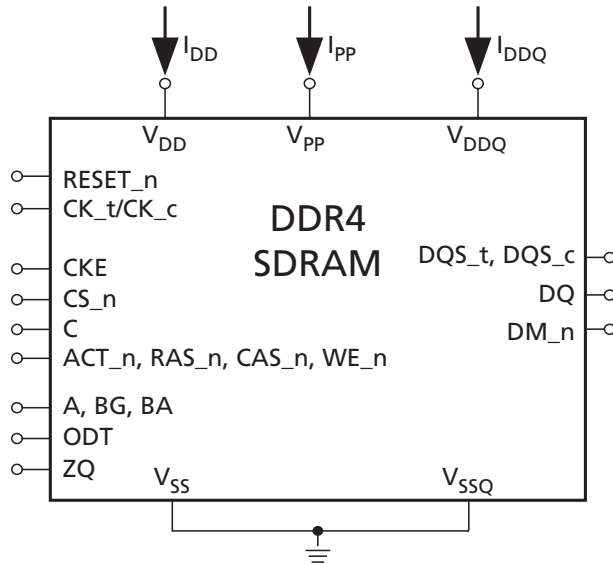
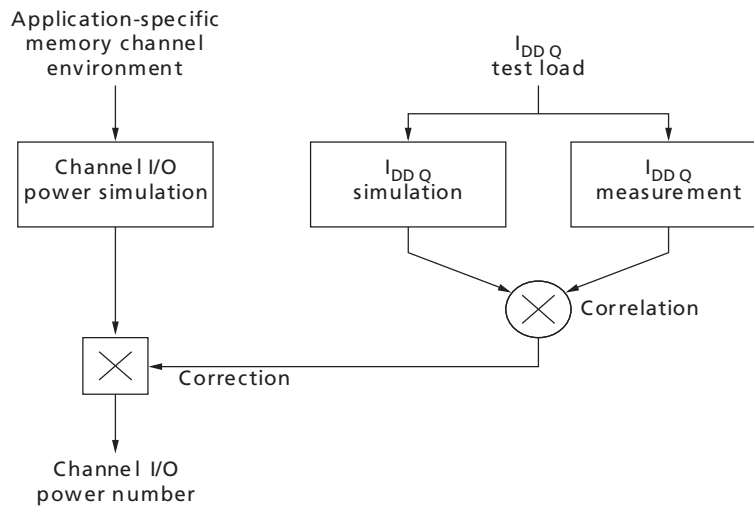


Figure 235: Correlation: Simulated Channel I/O Power to Actual Channel I/O Power



Note: 1. Supported by  $I_{DDQ}$  measurement.

## $I_{DD}$ Definitions

Table 128: Basic  $I_{DD}$ ,  $I_{PP}$ , and  $I_{DDQ}$  Measurement Conditions

Symbol	Description
$I_{DD0}$	<p><b>Operating One Bank Active-Precharge Current (AL = 0)</b>            CKE: HIGH; External clock: On; <math>t_{CK}</math>, <math>nRC</math>, <math>nRAS</math>, CL: see the previous table; BL: 8;<sup>1</sup> AL: 0; CS<sub>n</sub>: HIGH between ACT and PRE; Command, address, bank group address, bank address inputs: partially toggling according to the next table; Data I/O: <math>V_{DDQ}</math>; DM<sub>n</sub>: stable at 0; Bank activity: cycling with one bank active at a time: 0, 0, 1, 1, 2, 2, ... (see the <math>I_{DD0}</math> Measurement-Loop Pattern table); Output buffer and <math>R_{TT}</math>: enabled in mode registers;<sup>2</sup> ODT signal: stable at 0; Pattern details: see the <math>I_{DD0}</math> Measurement-Loop Pattern table</p>

**Table 128: Basic  $I_{DD}$ ,  $I_{PP}$ , and  $I_{DDQ}$  Measurement Conditions (Continued)**

Symbol	Description
$I_{PP0}$	<b>Operating One Bank Active-Precharge <math>I_{PP}</math> Current (AL = 0)</b> Same conditions as $I_{DD0}$ above
$I_{DD1}$	<b>Operating One Bank Active-Read-Precharge Current (AL = 0)</b> CKE: HIGH; External clock: on; $^tCK$ , $nRC$ , $nRAS$ , $nRCD$ , CL: see the previous table; BL: 8; <sup>1, 5</sup> AL: 0; CS <sub>n</sub> : HIGH between ACT, RD, and PRE; Command, address, bank group address, bank address inputs, Data I/O: partially toggling according to the $I_{DD1}$ Measurement-Loop Pattern table; DM <sub>n</sub> : stable at 0; Bank activity: cycling with one bank active at a time: 0, 0, 1, 1, 2, 2, ... (see the following table); Output buffer and R <sub>TT</sub> : enabled in mode registers; <sup>2</sup> ODT Signal: stable at 0; Pattern details: see the $I_{DD1}$ Measurement-Loop Pattern table
$I_{DD2N}$	<b>Precharge Standby Current (AL = 0)</b> CKE: HIGH; External clock: On; $^tCK$ , CL: see the previous table; BL: 8; <sup>1</sup> AL: 0; CS <sub>n</sub> : stable at 1; Command, address, bank group address, bank address inputs: partially toggling according to the $I_{DD2N}$ and $I_{DD3N}$ Measurement-Loop Pattern table; Data I/O: $V_{DDQ}$ ; DM <sub>n</sub> : stable at 1; Bank activity: all banks closed; Output buffer and R <sub>TT</sub> : enabled in mode registers; <sup>2</sup> ODT signal: stable at 0; Pattern details: see the $I_{DD2N}$ and $I_{DD3N}$ Measurement-Loop Pattern table
$I_{DD2NT}$	<b>Precharge Standby ODT Current</b> CKE: HIGH; External clock: on; $^tCK$ , CL: see the previous table; BL: 8; <sup>1</sup> AL: 0; CS <sub>n</sub> : stable at 1; Command, address, bank group address, bank address inputs: partially toggling according to the $I_{DD2NT}$ and $I_{DDQ2NT}$ Measurement-Loop Pattern table; Data I/O: $V_{SSQ}$ ; DM <sub>n</sub> : stable at 1; Bank activity: all banks closed; Output buffer and R <sub>TT</sub> : enabled in mode registers; <sup>2</sup> ODT signal: toggling according to the $I_{DD2NT}$ and $I_{DDQ2NT}$ Measurement-Loop Pattern table; Pattern details: see the $I_{DD2NT}$ and $I_{DDQ2NT}$ Measurement-Loop Pattern table
$I_{DDQ2NT}$	<b>Precharge Standby ODT <math>I_{DDQ}</math> Current</b> Has the same definition as $I_{DD2NT}$ above, with the exception of measuring $I_{DDQ}$ current instead of $I_{DD}$ current
$I_{DD2P}$	<b>Precharge Power-Down Current</b> CKE: LOW; External clock: on; $^tCK$ , CL: see the previous table; BL: 8; <sup>1</sup> AL: 0; CS <sub>n</sub> : stable at 1; Command, address, bank group address, bank address inputs: stable at 0; Data I/O: $V_{DDQ}$ ; DM <sub>n</sub> : stable at 1; Bank activity: all banks closed; Output buffer and R <sub>TT</sub> : Enabled in mode registers; <sup>2</sup> ODT signal: stable at 0
$I_{DD2Q}$	<b>Precharge Quiet Standby Current</b> CKE: HIGH; External clock: on; $^tCK$ , CL: see the previous table; BL: 8; <sup>1</sup> AL: 0; CS <sub>n</sub> : stable at 1; Command, address, bank group address, bank address inputs: stable at 0; Data I/O: $V_{DDQ}$ ; DM <sub>n</sub> : stable at 1; Bank activity: all banks closed; Output buffer and R <sub>TT</sub> : Enabled in mode registers; <sup>2</sup> ODT signal: stable at 0
$I_{DD3N}$	<b>Active Standby Current (AL = 0)</b> CKE: HIGH; External clock: on; $^tCK$ , CL: see the previous table; BL: 8; <sup>1</sup> AL: 0; CS <sub>n</sub> : stable at 1; Command, address, bank group address, bank address inputs: partially toggling according to the $I_{DD2N}$ and $I_{DD3N}$ Measurement-Loop Pattern table; Data I/O: $V_{DDQ}$ ; DM <sub>n</sub> : stable at 1; Bank activity: all banks open; Output buffer and R <sub>TT</sub> : Enabled in mode registers; <sup>2</sup> ODT signal: stable at 0; Pattern details: see the $I_{DD2N}$ and $I_{DD3N}$ Measurement-Loop Pattern table
$I_{PPSB}$	<b>Active Standby <math>I_{PPSB}</math> Current (AL = 0)</b> Same conditions as $I_{DD3N}$ above
$I_{DD3P}$	<b>Active Power-Down Current (AL = 0)</b> CKE: LOW; External clock: on; $^tCK$ , CL: see the previous table; BL: 8; <sup>1</sup> AL: 0; CS <sub>n</sub> : stable at 1; Command, address, bank group address, bank address inputs: stable at 1; Data I/O: $V_{DDQ}$ ; DM <sub>n</sub> : stable at 1; Bank activity: all banks open; Output buffer and R <sub>TT</sub> : Enabled in mode registers; <sup>2</sup> ODT signal: stable at 0

**Table 128: Basic I<sub>DD</sub>, I<sub>PP</sub>, and I<sub>DDQ</sub> Measurement Conditions (Continued)**

Symbol	Description
I <sub>DD4R</sub>	<b>Operating Burst Read Current (AL = 0)</b> CKE: HIGH; External clock: on; <sup>t</sup> CK, CL: see the previous table; BL: 8; <sup>15</sup> AL: 0; CS_n: HIGH between RD; Command, address, bank group address, bank address inputs: partially toggling according to the I <sub>DD4R</sub> and I <sub>DDQ4R</sub> Measurement-Loop Pattern table; Data I/O: seamless read data burst with different data between one burst and the next one according to the I <sub>DD4R</sub> and I <sub>DDQ4R</sub> Measurement-Loop Pattern table; DM_n: stable at 1; Bank activity: all banks open, RD commands cycling through banks: 0, 0, 1, 1, 2, 2, ... (see the I <sub>DD4R</sub> and I <sub>DDQ4R</sub> Measurement-Loop Pattern table); Output buffer and R <sub>TT</sub> : Enabled in mode registers; <sup>2</sup> ODT signal: stable at 0; Pattern details: see the I <sub>DD4R</sub> and I <sub>DDQ4R</sub> Measurement-Loop Pattern table
I <sub>DDQ4R</sub>	<b>Operating Burst Read I<sub>DDQ</sub> Current</b> Has the same definition as I <sub>DD4R</sub> , with the exception of measuring I <sub>DDQ</sub> current instead of I <sub>DD</sub> current
I <sub>DD4W</sub>	<b>Operating Burst Write Current (AL = 0)</b> CKE: HIGH; External clock: on; <sup>t</sup> CK, CL: see the previous table; BL: 8; <sup>1</sup> AL: 0; CS_n: HIGH between WR; Command, address, bank group address, bank address inputs: partially toggling according to the I <sub>DD4W</sub> Measurement-Loop Pattern table; Data I/O: seamless write data burst with different data between one burst and the next one according to the I <sub>DD4W</sub> Measurement-Loop Pattern table; DM: stable at 0; Bank activity: all banks open, WR commands cycling through banks: 0, 0, 1, 1, 2, 2, ... (see I <sub>DD4W</sub> Measurement-Loop Pattern table); Output buffer and R <sub>TT</sub> : enabled in mode registers (see note2); ODT signal: stable at HIGH; Pattern details: see the I <sub>DD4W</sub> Measurement-Loop Pattern table
I <sub>DD5B</sub>	<b>Burst Refresh Current (1X REF)</b> CKE: HIGH; External clock: on; <sup>t</sup> CK, CL, nRFC: see the previous table; BL: 8; <sup>1</sup> AL: 0; CS_n: HIGH between REF; Command, address, bank group address, bank address inputs: partially toggling according to the I <sub>DD5B</sub> Measurement-Loop Pattern table; Data I/O: V <sub>DDQ</sub> ; DM_n: stable at 1; Bank activity: REF command every nRFC (see the I <sub>DD5B</sub> Measurement-Loop Pattern table); Output buffer and R <sub>TT</sub> : enabled in mode registers <sup>2</sup> ; ODT signal: stable at 0; Pattern details: see the I <sub>DD5B</sub> Measurement-Loop Pattern table
I <sub>PP5B</sub>	<b>Burst Refresh Current (1X REF)</b> Same conditions as I <sub>DD5B</sub> above
I <sub>DD6N</sub>	<b>Self Refresh Current: Normal Temperature Range</b> T <sub>C</sub> : 0–85°C; Auto self refresh (ASR): disabled; <sup>3</sup> Self refresh temperature range (SRT): normal; <sup>4</sup> CKE: LOW; External clock: off; CK_t and CK_c: LOW; CL: see the table above; BL: 8; <sup>1</sup> AL: 0; CS_n, command, address, bank group address, bank address, data I/O: V <sub>DDQ</sub> ; DM_n: stable at 1; Bank activity: SELF REFRESH operation; Output buffer and R <sub>TT</sub> : enabled in mode registers; <sup>2</sup> ODT signal: midlevel
I <sub>PP6N</sub>	<b>Self Refresh I<sub>PP</sub> Current: Normal Temperature Range</b> Same conditions as I <sub>DD6N</sub> above
I <sub>DD6E</sub>	<b>Self Refresh Current: Extended Temperature Range <sup>4</sup></b> T <sub>C</sub> : 0–95°C; Auto self refresh (ASR): disabled <sup>4</sup> ; Self refresh temperature range (SRT): extended; <sup>4</sup> CKE: LOW; External clock: off; CK_t and CK_c: LOW; CL: see the previous table; BL: 8; <sup>1</sup> AL: 0; CS_n, command, address, group bank address, bank address, data I/O: V <sub>DDQ</sub> ; DM_n: stable at 1; Bank activity: EXTENDED TEMPERATURE SELF REFRESH operation; Output buffer and R <sub>TT</sub> : enabled in mode registers; <sup>2</sup> ODT signal: midlevel
I <sub>DD6R</sub>	<b>Self Refresh Current: Reduced Temperature Range</b> T <sub>C</sub> : 0–45°C; Auto self refresh (ASR): disabled; Self refresh temperature range (SRT): reduced; <sup>4</sup> CKE: LOW; External clock: off; CK_t and CK_c: LOW; CL: see the previous table; BL: 8; <sup>1</sup> AL: 0; CS_n, command, address, bank group address, bank address, data I/O: V <sub>DDQ</sub> ; DM_n: stable at 1; Bank activity: EXTENDED TEMPERATURE SELF REFRESH operation; Output buffer and R <sub>TT</sub> : enabled in mode registers; <sup>2</sup> ODT signal: midlevel

**Table 128: Basic  $I_{DD}$ ,  $I_{PP}$ , and  $I_{DDQ}$  Measurement Conditions (Continued)**

Symbol	Description
$I_{DD7}$	<b>Operating Bank Interleave Read Current</b> CKE: HIGH; External clock: on; $t^*CK$ , $nRC$ , $nRAS$ , $nRCD$ , $nRRD$ , $nFAW$ , CL: see the previous table; BL: 8; <sup>15</sup> AL: CL - 1; CS_n: HIGH between ACT and RDA; Command, address, group bank address, bank address inputs: partially toggling according to the $I_{DD7}$ Measurement-Loop Pattern table; Data I/O: read data bursts with different data between one burst and the next one according to the $I_{DD7}$ Measurement-Loop Pattern table; DM: stable at 1; Bank activity: two times interleaved cycling through banks (0, 1, ...7) with different addressing, see the $I_{DD7}$ Measurement-Loop Pattern table; Output buffer and $R_{TT}$ : enabled in mode registers; <sup>2</sup> ODT signal: stable at 0; Pattern details: see the $I_{DD7}$ Measurement-Loop Pattern table
$I_{PP7}$	<b>Operating Bank Interleave Read <math>I_{PP}</math> Current</b> Same conditions as $I_{DD7}$ above
$I_{DD8}$	<b>Maximum Power Down Current</b> Place DRAM in MPSM then CKE: HIGH; External clock: on; $t^*CK$ , CL: see the previous table; BL: 8; <sup>1</sup> AL: 0; CS_n: stable at 1; Command, address, bank group address, bank address inputs: stable at 0; Data I/O: $V_{DDQ}$ ; DM_n: stable at 1; Bank activity: all banks closed; Output buffer and $R_{TT}$ : Enabled in mode registers; <sup>2</sup> ODT signal: stable at 0

- Notes:
1. Burst length: BL8 fixed by MRS: set MR0[1:0] 00.
  2. Output buffer enable: set MR1[12] 0 (output buffer enabled); set MR1[2:1] 00 ( $R_{ON} = R_{ZQ}/7$ );  $R_{TT(NOM)}$  enable: set MR1[10:8] 011 ( $R_{ZQ}/6$ );  $R_{TT(WR)}$  enable: set MR2[11:9] 001 ( $R_{ZQ}/2$ ), and  $R_{TT(Park)}$  enable: set MR5[8:6] 000 (disabled).
  3. Auto self refresh (ASR): set MR2[6] 0 to disable or MR2[6] 1 to enable feature.
  4. Self refresh temperature range (SRT): set MR2[7] 0 for normal or MR2[7] 1 for extended temperature range.
  5. READ burst type: Nibble sequential, set MR0[3] 0.

## Current Specifications – Patterns and Test Conditions

### Current Test Definitions and Patterns

Table 129: I<sub>DDQ</sub> and I<sub>PP0</sub> Measurement-Loop Pattern<sup>1</sup>

CK_t, CK_c	CKE	Sub-Loop	Cycle Number	Command	CS_n	ACT_n	RAS_n/A16	CAS_n/A15	WE_n/A14	ODT	BG[1:0] <sup>2</sup>	BA[1:0]	A12/BC_n	A[17,13,11]	A[10]/AP	A[9:7]	A[6:3]	A[2:0]	Data <sup>3</sup>		
Toggling	Static High	0	0	ACT	0	0	0	0	0	0	0	0	0	0	0	0	0	0	0	-	
			1, 2	D, D	1	0	0	0	0	0	0	0	0	0	0	0	0	0	0	0	-
			3, 4	D_n, D_n	1	1	1	1	1	0	3	3	0	0	0	7	F	0	0	-	
			...	Repeat pattern 1...4 until nRAS - 1; truncate if necessary																	
			nRAS	PRE	0	1	0	1	0	0	0	0	0	0	0	0	0	0	0	0	-
			...	Repeat pattern 1...4 until nRC - 1; truncate if necessary																	
		1	1 × nRC	Repeat sub-loop 0, use BG[1:0] = 1, use BA[1:0] = 1 instead																	
		2	2 × nRC	Repeat sub-loop 0, use BG[1:0] = 0, use BA[1:0] = 2 instead																	
		3	3 × nRC	Repeat sub-loop 0, use BG[1:0] = 1, use BA[1:0] = 3 instead																	
		4	4 × nRC	Repeat sub-loop 0, use BG[1:0] = 0, use BA[1:0] = 1 instead																	
		5	5 × nRC	Repeat sub-loop 0, use BG[1:0] = 1, use BA[1:0] = 2 instead																	
		6	6 × nRC	Repeat sub-loop 0, use BG[1:0] = 0, use BA[1:0] = 3 instead																	
		7	7 × nRC	Repeat sub-loop 0, use BG[1:0] = 1, use BA[1:0] = 0 instead																	
		8	8 × nRC	Repeat sub-loop 0, use BG[1:0] = 2, use BA[1:0] = 0 instead <sup>4</sup>																	
		9	9 × nRC	Repeat sub-loop 0, use BG[1:0] = 3, use BA[1:0] = 1 instead <sup>4</sup>																	
		10	10 × nRC	Repeat sub-loop 0, use BG[1:0] = 2, use BA[1:0] = 2 instead <sup>4</sup>																	
11	11 × nRC	Repeat sub-loop 0, use BG[1:0] = 3, use BA[1:0] = 3 instead <sup>4</sup>																			
12	12 × nRC	Repeat sub-loop 0, use BG[1:0] = 2, use BA[1:0] = 1 instead <sup>4</sup>																			
13	13 × nRC	Repeat sub-loop 0, use BG[1:0] = 3, use BA[1:0] = 2 instead <sup>4</sup>																			
14	14 × nRC	Repeat sub-loop 0, use BG[1:0] = 2, use BA[1:0] = 3 instead <sup>4</sup>																			
15	15 × nRC	Repeat sub-loop 0, use BG[1:0] = 3, use BA[1:0] = 0 instead <sup>4</sup>																			

- Notes:
1. DQS\_t, DQS\_c are V<sub>DDQ</sub>.
  2. BG1 is a "Don't Care" for x16 devices.
  3. DQ signals are V<sub>DDQ</sub>.
  4. For x4 and x8 only.

Table 130: I<sub>DD1</sub> Measurement-Loop Pattern<sup>1</sup>

CK_c, CK_t,	CKE	Sub-Loop	Cycle Number	Command	CS_n	ACT_n	RAS_n/A16	CAS_n/A15	WE_n/A14	ODT	BG[1:0] <sup>2</sup>	BA[1:0]	A12/BC_n	A[17,13,11]	A[10]/AP	A[9:7]	A[6:3]	A[2:0]	Data <sup>3</sup>			
Toggling	Static High	0	0	ACT	0	0	0	0	0	0	0	0	0	0	0	0	0	0	0	–		
			1, 2	D, D	1	0	0	0	0	0	0	0	0	0	0	0	0	0	0	0	–	
			3, 4	D_n, D_n	1	1	1	1	1	1	0	3	3	0	0	0	7	F	0	–		
			...	Repeat pattern 1...4 until nRCD - AL - 1; truncate if necessary																		
			nRCD - AL	RD	0	1	1	0	1	0	0	0	0	0	0	0	0	0	0	0	0	D0 = 00, D1 = FF, D2 = FF, D3 = 00, D4 = FF, D5 = 00, D5 = 00, D7 = FF
			...	Repeat pattern 1...4 until nRAS - 1; truncate if necessary																		
			nRAS	PRE	0	1	0	1	0	0	0	0	0	0	0	0	0	0	0	0	0	
		...	Repeat pattern 1...4 until nRC - 1; truncate if necessary																			
		1	1 × nRC + 0	ACT	0	0	0	1	1	0	1	1	0	0	0	0	0	0	0	0	–	
			1 × nRC + 1, 2	D, D	1	0	0	0	0	0	0	0	0	0	0	0	0	0	0	0	–	
			1 × nRC + 3, 4	D_n, D_n	1	1	1	1	1	0	3	3	0	0	0	7	F	0	–			
			...	Repeat pattern nRC + 1...4 until 1 × nRC + nRAS - 1; truncate if necessary																		
			1 × nRC + nRCD - AL	RD	0	1	1	0	1	0	1	1	0	0	0	0	0	0	0	0	0	D0 = FF, D1 = 00, D2 = 00, D3 = FF, D4 = 00, D5 = FF, D5 = FF, D7 = 00
			...	Repeat pattern 1...4 until nRAS - 1; truncate if necessary																		
			1 × nRC + nRAS	PRE	0	1	0	1	0	0	1	1	0	0	0	0	0	0	0	0	0	
		...	Repeat pattern nRC + 1...4 until 2 × nRC - 1; truncate if necessary																			
		2	2 × nRC	Repeat sub-loop 0, use BG[1:0] = 0, use BA[1:0] = 2 instead																		
		3	3 × nRC	Repeat sub-loop 0, use BG[1:0] = 1, use BA[1:0] = 3 instead																		
		4	4 × nRC	Repeat sub-loop 0, use BG[1:0] = 0, use BA[1:0] = 1 instead																		
		5	5 × nRC	Repeat sub-loop 0, use BG[1:0] = 1, use BA[1:0] = 2 instead																		
		6	6 × nRC	Repeat sub-loop 0, use BG[1:0] = 0, use BA[1:0] = 3 instead																		
		7	7 × nRC	Repeat sub-loop 0, use BG[1:0] = 1, use BA[1:0] = 0 instead																		
		8	9 × nRC	Repeat sub-loop 0, use BG[1:0] = 2, use BA[1:0] = 0 instead <sup>4</sup>																		
		9	10 × nRC	Repeat sub-loop 0, use BG[1:0] = 3, use BA[1:0] = 1 instead <sup>4</sup>																		
		10	11 × nRC	Repeat sub-loop 0, use BG[1:0] = 2, use BA[1:0] = 2 instead <sup>4</sup>																		
		11	12 × nRC	Repeat sub-loop 0, use BG[1:0] = 3, use BA[1:0] = 3 instead <sup>4</sup>																		
		12	13 × nRC	Repeat sub-loop 0, use BG[1:0] = 2, use BA[1:0] = 1 instead <sup>4</sup>																		
		13	14 × nRC	Repeat sub-loop 0, use BG[1:0] = 3, use BA[1:0] = 2 instead <sup>4</sup>																		
		14	15 × nRC	Repeat sub-loop 0, use BG[1:0] = 2, use BA[1:0] = 3 instead <sup>4</sup>																		
		15	16 × nRC	Repeat sub-loop 0, use BG[1:0] = 3, use BA[1:0] = 0 instead <sup>4</sup>																		

Notes: 1. DQS\_t, DQS\_c are V<sub>DDQ</sub> when not toggling.

2. BG1 is a "Don't Care" for x16 devices.
3. DQ signals are  $V_{DDQ}$  except when burst sequence drives each DQ signal by a READ command.
4. For x4 and x8 only.

**Table 131:  $I_{DD2N}$ ,  $I_{DD3N}$ , and  $I_{pp3p}$  Measurement-Loop Pattern<sup>1</sup>**

CK_c, CK_t	CKE	Sub-Loop	Cycle Number	Command	CS_n	ACT_n	RAS_n/A16	CAS_n/A15	WE_n/A14	ODT	BG[1:0] <sup>2</sup>	BA[1:0]	A12/BC_n	A[17,13,11]	A[10]/AP	A[9:7]	A[6:3]	A[2:0]	Data <sup>3</sup>		
Toggling	Static High	0	0	D	1	0	0	0	0	0	0	0	0	0	0	0	0	0	0	-	
			1	D	1	0	0	0	0	0	0	0	0	0	0	0	0	0	0	0	-
			2	D_n	1	1	1	1	1	1	0	3	3	0	0	0	7	F	0	0	-
			3	D_n	1	1	1	1	1	1	0	3	3	0	0	0	7	F	0	0	-
		1	4–7	Repeat sub-loop 0, use BG[1:0] = 1, use BA[1:0] = 1 instead																	
		2	8–11	Repeat sub-loop 0, use BG[1:0] = 0, use BA[1:0] = 2 instead																	
		3	12–15	Repeat sub-loop 0, use BG[1:0] = 1, use BA[1:0] = 3 instead																	
		4	16–19	Repeat sub-loop 0, use BG[1:0] = 0, use BA[1:0] = 1 instead																	
		5	20–23	Repeat sub-loop 0, use BG[1:0] = 1, use BA[1:0] = 2 instead																	
		6	24–27	Repeat sub-loop 0, use BG[1:0] = 0, use BA[1:0] = 3 instead																	
		7	28–31	Repeat sub-loop 0, use BG[1:0] = 1, use BA[1:0] = 0 instead																	
		8	32–35	Repeat sub-loop 0, use BG[1:0] = 2, use BA[1:0] = 0 instead <sup>4</sup>																	
		9	36–39	Repeat sub-loop 0, use BG[1:0] = 3, use BA[1:0] = 1 instead <sup>4</sup>																	
		10	40–43	Repeat sub-loop 0, use BG[1:0] = 2, use BA[1:0] = 2 instead <sup>4</sup>																	
		11	44–47	Repeat sub-loop 0, use BG[1:0] = 3, use BA[1:0] = 3 instead <sup>4</sup>																	
		12	48–51	Repeat sub-loop 0, use BG[1:0] = 2, use BA[1:0] = 1 instead <sup>4</sup>																	
13	52–55	Repeat sub-loop 0, use BG[1:0] = 3, use BA[1:0] = 2 instead <sup>4</sup>																			
14	56–59	Repeat sub-loop 0, use BG[1:0] = 2, use BA[1:0] = 3 instead <sup>4</sup>																			
15	60–63	Repeat sub-loop 0, use BG[1:0] = 3, use BA[1:0] = 0 instead <sup>4</sup>																			

- Notes:
1. DQS\_t, DQS\_c are  $V_{DDQ}$ .
  2. BG1 is a "Don't Care" for x16 devices.
  3. DQ signals are  $V_{DDQ}$ .
  4. For x4 and x8 only.

Table 132: I<sub>DD2NT</sub> and I<sub>DDQ2NT</sub> Measurement-Loop Pattern<sup>1</sup>

CK_c, CK_t,	CKE	Sub-Loop	Cycle Number	Command	CS_n	ACT_n	RAS_n/A16	CAS_n/A15	WE_n/A14	ODT	BG[1:0] <sup>2</sup>	BA[1:0]	A12/BC_n	A[17,13,11]	A[10]/AP	A[9:7]	A[6:3]	A[2:0]	Data <sup>3</sup>		
Toggling	Static High	0	0	D	1	0	0	0	0	0	0	0	0	0	0	0	0	0	0	-	
			1	D	1	0	0	0	0	0	0	0	0	0	0	0	0	0	0	0	-
			2	D_n	1	1	1	1	1	1	0	3	3	0	0	0	7	F	0	0	-
			3	D_n	1	1	1	1	1	1	0	3	3	0	0	0	7	F	0	0	-
		1	4–7	Repeat sub-loop 0 with ODT = 1, use BG[1:0] = 1, use BA[1:0] = 1 instead																	
		2	8–11	Repeat sub-loop 0 with ODT = 0, use BG[1:0] = 0, use BA[1:0] = 2 instead																	
		3	12–15	Repeat sub-loop 0 with ODT = 1, use BG[1:0] = 1, use BA[1:0] = 3 instead																	
		4	16–19	Repeat sub-loop 0 with ODT = 0, use BG[1:0] = 0, use BA[1:0] = 1 instead																	
		5	20–23	Repeat sub-loop 0 with ODT = 1, use BG[1:0] = 1, use BA[1:0] = 2 instead																	
		6	24–27	Repeat sub-loop 0 with ODT = 0, use BG[1:0] = 0, use BA[1:0] = 3 instead																	
		7	28–31	Repeat sub-loop 0 with ODT = 1, use BG[1:0] = 1, use BA[1:0] = 0 instead																	
		8	32–35	Repeat sub-loop 0 with ODT = 0, use BG[1:0] = 2, use BA[1:0] = 0 instead <sup>4</sup>																	
		9	36–39	Repeat sub-loop 0 with ODT = 1, use BG[1:0] = 3, use BA[1:0] = 1 instead <sup>4</sup>																	
		10	40–43	Repeat sub-loop 0 with ODT = 0, use BG[1:0] = 2, use BA[1:0] = 2 instead <sup>4</sup>																	
		11	44–47	Repeat sub-loop 0 with ODT = 1, use BG[1:0] = 3, use BA[1:0] = 3 instead <sup>4</sup>																	
		12	48–51	Repeat sub-loop 0 with ODT = 0, use BG[1:0] = 2, use BA[1:0] = 1 instead <sup>4</sup>																	
13	52–55	Repeat sub-loop 0 with ODT = 1, use BG[1:0] = 3, use BA[1:0] = 2 instead <sup>4</sup>																			
14	56–59	Repeat sub-loop 0 with ODT = 0, use BG[1:0] = 2, use BA[1:0] = 3 instead <sup>4</sup>																			
15	60–63	Repeat sub-loop 0 with ODT = 1, use BG[1:0] = 3, use BA[1:0] = 0 instead <sup>4</sup>																			

- Notes:
1. DQS\_t, DQS\_c are V<sub>SSQ</sub>.
  2. BG1 is a "Don't Care" for x16 devices.
  3. DQ signals are V<sub>SSQ</sub>.
  4. For x4 and x8 only.

**Table 133: I<sub>DD4R</sub> and I<sub>DDQ4R</sub> Measurement-Loop Pattern<sup>1</sup>**

CK_c, CK_t,	CKE	Sub-Loop	Cycle Number	Command	CS_n	ACT_n	RAS_n/A16	CAS_n/A15	WE_n/A14	ODT	BG[1:0] <sup>2</sup>	BA[1:0]	A12/BC_n	A[17,13,11]	A[10]/AP	A[9:7]	A[6:3]	A[2:0]	Data <sup>3</sup>		
Toggling	Static High	0	0	RD	0	1	1	0	1	0	0	0	0	0	0	0	0	0	0	D0 = 00, D1 = FF, D2 = FF, D3 = 00, D4 = FF, D5 = 00, D5 = 00, D7 = FF	
			1	D	1	0	0	0	0	0	0	0	0	0	0	0	0	0	0		
			2, 3	D_n, D_n	1	1	1	1	1	1	0	3	3	0	0	0	7	F	0		
		1	4	RD	0	1	1	0	1	0	1	0	1	1	0	0	0	7	F	0	D0 = FF, D1 = 00 D2 = 00, D3 = FF D4 = 00, D5 = FF D5 = FF, D7 = 00
			5	D	1	0	0	0	0	0	0	0	0	0	0	0	0	0	0	0	
			6, 7	D_n, D_n	1	1	1	1	1	1	0	3	3	0	0	0	7	F	0		
		2	8–11	Repeat sub-loop 0, use BG[1:0] = 0, use BA[1:0] = 2 instead																	
		3	12–15	Repeat sub-loop 1, use BG[1:0] = 1, use BA[1:0] = 3 instead																	
		4	16–19	Repeat sub-loop 0, use BG[1:0] = 0, use BA[1:0] = 1 instead																	
		5	20–23	Repeat sub-loop 1, use BG[1:0] = 1, use BA[1:0] = 2 instead																	
		6	24–27	Repeat sub-loop 0, use BG[1:0] = 0, use BA[1:0] = 3 instead																	
		7	28–31	Repeat sub-loop 1, use BG[1:0] = 1, use BA[1:0] = 0 instead																	
		8	32–35	Repeat sub-loop 0, use BG[1:0] = 2, use BA[1:0] = 0 instead <sup>4</sup>																	
		9	36–39	Repeat sub-loop 1, use BG[1:0] = 3, use BA[1:0] = 1 instead <sup>4</sup>																	
		10	40–43	Repeat sub-loop 0, use BG[1:0] = 2, use BA[1:0] = 2 instead <sup>4</sup>																	
11	44–47	Repeat sub-loop 1, use BG[1:0] = 3, use BA[1:0] = 3 instead <sup>4</sup>																			
12	48–51	Repeat sub-loop 0, use BG[1:0] = 2, use BA[1:0] = 1 instead <sup>4</sup>																			
13	52–55	Repeat sub-loop 1, use BG[1:0] = 3, use BA[1:0] = 2 instead <sup>4</sup>																			
14	56–59	Repeat sub-loop 0, use BG[1:0] = 2, use BA[1:0] = 3 instead <sup>4</sup>																			
15	60–63	Repeat sub-loop 1, use BG[1:0] = 3, use BA[1:0] = 0 instead <sup>4</sup>																			

- Notes:
1. DQS\_t, DQS\_c are V<sub>DDQ</sub> when not toggling.
  2. BG1 is a "Don't Care" for x16 devices.
  3. Burst sequence driven on each DQ signal by a READ command. Outside burst operation, DQ signals are V<sub>DDQ</sub>.
  4. For x4 and x8 only.

Table 134: I<sub>DD4W</sub> Measurement-Loop Pattern<sup>1</sup>

CK <sub>c</sub> , CK <sub>t</sub>	CKE	Sub-Loop	Cycle Number	Com- mand	CS <sub>n</sub>	ACT <sub>n</sub>	RAS <sub>n</sub> /A1 6	CAS <sub>n</sub> /A1 5	WE <sub>n</sub> /A14	ODT	BG[1:0] <sup>2</sup>	BA[1:0]	A12/BC <sub>n</sub>	A[17,13,1 1]	A[10]/AP	A[9:7]	A[6:3]	A[2:0]	Data <sup>3</sup>	
Toggling	Static High	0	0	WR	0	1	1	0	0	1	0	0	0	0	0	0	0	0	D0 = 00, D1 = FF,	
			1	D	1	0	0	0	0	1	0	0	0	0	0	0	0	0	D2 = FF, D3 = 00,	
			2, 3	D <sub>n</sub> , D <sub>n</sub>	1	1	1	1	0	1	3	3	0	0	0	7	F	0	D4 = FF, D5 = 00, D5 = 00, D7 = FF	
		1	4	WR	0	1	1	0	0	0	1	1	1	0	0	0	7	F	0	D0 = FF, D1 = 00
			5	D	1	0	0	0	0	0	1	0	0	0	0	0	0	0	0	D2 = 00, D3 = FF
			6, 7	D <sub>n</sub> , D <sub>n</sub>	1	1	1	1	0	1	3	3	0	0	0	7	F	0	D4 = 00, D5 = FF D5 = FF, D7 = 00	
		2	8–11	Repeat sub-loop 0, use BG[1:0] = 0, use BA[1:0] = 2 instead																
		3	12–15	Repeat sub-loop 1, use BG[1:0] = 1, use BA[1:0] = 3 instead																
		4	16–19	Repeat sub-loop 0, use BG[1:0] = 0, use BA[1:0] = 1 instead																
		5	20–23	Repeat sub-loop 1, use BG[1:0] = 1, use BA[1:0] = 2 instead																
		6	24–27	Repeat sub-loop 0, use BG[1:0] = 0, use BA[1:0] = 3 instead																
		7	28–31	Repeat sub-loop 1, use BG[1:0] = 1, use BA[1:0] = 0 instead																
		8	32–35	Repeat sub-loop 0, use BG[1:0] = 2, use BA[1:0] = 0 instead <sup>4</sup>																
		9	36–39	Repeat sub-loop 1, use BG[1:0] = 3, use BA[1:0] = 1 instead <sup>4</sup>																
		10	40–43	Repeat sub-loop 0, use BG[1:0] = 2, use BA[1:0] = 2 instead <sup>4</sup>																
11	44–47	Repeat sub-loop 1, use BG[1:0] = 3, use BA[1:0] = 3 instead <sup>4</sup>																		
12	48–51	Repeat sub-loop 0, use BG[1:0] = 2, use BA[1:0] = 1 instead <sup>4</sup>																		
13	52–55	Repeat sub-loop 1, use BG[1:0] = 3, use BA[1:0] = 2 instead <sup>4</sup>																		
14	56–59	Repeat sub-loop 0, use BG[1:0] = 2, use BA[1:0] = 3 instead <sup>4</sup>																		
15	60–63	Repeat sub-loop 1, use BG[1:0] = 3, use BA[1:0] = 0 instead <sup>4</sup>																		

- Notes:
1. DQS<sub>t</sub>, DQS<sub>c</sub> are V<sub>DDQ</sub> when not toggling.
  2. BG1 is a "Don't Care" for x16 devices.
  3. Burst sequence driven on each DQ signal by WRITE command. Outside burst operation, DQ signals are V<sub>DDQ</sub>.
  4. For x4 and x8 only.

Table 135: I<sub>DD4Wc</sub> Measurement-Loop Pattern<sup>1</sup>

CK_c, CK_t,	CKE	Sub-Loop	Cycle Number	Command	CS_n	ACT_n	RAS_n/A16	CAS_n/A15	WE_n/A14	ODT	BG[1:0] <sup>3</sup>	BA[1:0]	A12/BC_n	A[17,13,11]	A[10]/AP	A[9:7]	A[6:3]	A[2:0]	Data <sup>4</sup>	
Toggling	Static High	0	0	WR	0	1	1	0	0	1	0	0	0	0	0	0	0	0	0	D0 = 00, D1 = FF, D2 = FF, D3 = 00, D4 = FF, D5 = 00, D8 = CRC
			1, 2	D, D	1	0	0	0	0	1	0	0	0	0	0	0	0	0	0	
			3, 4	D_n, D_n	1	1	1	1	0	1	3	3	0	0	0	7	F	0		
		1	5	WR	0	1	1	0	0	0	1	1	1	0	0	0	7	F	0	D0 = FF, D1 = 00, D2 = 00, D3 = FF, D4 = 00, D5 = FF, D5 = FF, D7 = 00 D8 = CRC
			6, 7	D, D	1	0	0	0	0	1	0	0	0	0	0	0	0	0	0	
			8, 9	D_n, D_n	1	1	1	1	0	1	3	3	0	0	0	7	F	0		
		2	10–14	Repeat sub-loop 0, use BG[1:0] = 0, use BA[1:0] = 2 instead																
		3	15–19	Repeat sub-loop 1, use BG[1:0] = 1, use BA[1:0] = 3 instead																
		4	20–24	Repeat sub-loop 0, use BG[1:0] = 0, use BA[1:0] = 1 instead																
		5	25–29	Repeat sub-loop 1, use BG[1:0] = 1, use BA[1:0] = 2 instead																
		6	30–34	Repeat sub-loop 0, use BG[1:0] = 0, use BA[1:0] = 3 instead																
		7	35–39	Repeat sub-loop 1, use BG[1:0] = 1, use BA[1:0] = 0 instead																
		8	40–44	Repeat sub-loop 0, use BG[1:0] = 2, use BA[1:0] = 0 instead <sup>4</sup>																
		9	45–49	Repeat sub-loop 1, use BG[1:0] = 3, use BA[1:0] = 1 instead <sup>4</sup>																
		10	50–54	Repeat sub-loop 0, use BG[1:0] = 2, use BA[1:0] = 2 instead <sup>4</sup>																
11	55–59	Repeat sub-loop 1, use BG[1:0] = 3, use BA[1:0] = 3 instead <sup>4</sup>																		
12	60–64	Repeat sub-loop 0, use BG[1:0] = 2, use BA[1:0] = 1 instead <sup>4</sup>																		
13	65–69	Repeat sub-loop 1, use BG[1:0] = 3, use BA[1:0] = 2 instead <sup>4</sup>																		
14	70–74	Repeat sub-loop 0, use BG[1:0] = 2, use BA[1:0] = 3 instead <sup>4</sup>																		
15	75–79	Repeat sub-loop 1, use BG[1:0] = 3, use BA[1:0] = 0 instead <sup>4</sup>																		

- Notes:
1. Pattern provided for reference only.
  2. DQS\_t, DQS\_c are V<sub>DDQ</sub> when not toggling.
  3. BG1 is a "Don't Care" for x16 devices.
  4. Burst sequence driven on each DQ signal by WRITE command. Outside burst operation, DQ signals are V<sub>DDQ</sub>.
  5. For x4 and x8 only.

Table 136: I<sub>DD5b</sub> Measurement-Loop Pattern<sup>1</sup>

CK_c, CK_t,	CKE	Sub-Loop	Cycle Number	Command	CS_n	ACT_n	RAS_n/A16	CAS_n/A15	WE_n/A14	ODT	BG[1:0] <sup>2</sup>	BA[1:0]	A12/BC_n	A[17,13,11]	A[10]/AP	A[9:7]	A[6:3]	A[2:0]	Data <sup>3</sup>			
Toggling	Static High	0	0	REF	0	1	0	0	1	0	0	0	0	0	0	0	0	0	0	–		
		1	1	D	1	0	0	0	0	0	0	0	0	0	0	0	0	0	0	0	–	
			2	D	1	0	0	0	0	0	0	0	0	0	0	0	0	0	0	0	0	–
			3	D_n	1	1	1	1	1	1	0	3	3	0	0	0	7	F	0	0	0	–
			4	D_n	1	1	1	1	1	1	0	3	3	0	0	0	7	F	0	0	0	–
			5–8	Repeat pattern 1...4, use BG[1:0] = 1, use BA[1:0] = 1 instead																		
			9–12	Repeat pattern 1...4, use BG[1:0] = 0, use BA[1:0] = 2 instead																		
			13–16	Repeat pattern 1...4, use BG[1:0] = 1, use BA[1:0] = 3 instead																		
			17–20	Repeat pattern 1...4, use BG[1:0] = 0, use BA[1:0] = 1 instead																		
			21–24	Repeat pattern 1...4, use BG[1:0] = 1, use BA[1:0] = 2 instead																		
			25–28	Repeat pattern 1...4, use BG[1:0] = 0, use BA[1:0] = 3 instead																		
			29–32	Repeat pattern 1...4, use BG[1:0] = 1, use BA[1:0] = 0 instead																		
			33–36	Repeat pattern 1...4, use BG[1:0] = 2, use BA[1:0] = 0 instead <sup>4</sup>																		
			37–40	Repeat pattern 1...4, use BG[1:0] = 3, use BA[1:0] = 1 instead <sup>4</sup>																		
			41–44	Repeat pattern 1...4, use BG[1:0] = 2, use BA[1:0] = 2 instead <sup>4</sup>																		
			45–48	Repeat pattern 1...4, use BG[1:0] = 3, use BA[1:0] = 3 instead <sup>4</sup>																		
			49–52	Repeat pattern 1...4, use BG[1:0] = 2, use BA[1:0] = 1 instead <sup>4</sup>																		
			53–56	Repeat pattern 1...4, use BG[1:0] = 3, use BA[1:0] = 2 instead <sup>4</sup>																		
			57–60	Repeat pattern 1...4, use BG[1:0] = 2, use BA[1:0] = 3 instead <sup>4</sup>																		
			61–64	Repeat pattern 1...4, use BG[1:0] = 3, use BA[1:0] = 0 instead <sup>4</sup>																		
	2	65...nRFC - 1	Repeat sub-loop 1; truncate if necessary																			

- Notes:
1. DQS\_t, DQS\_c are V<sub>DDQ</sub>.
  2. BG1 is a "Don't Care" for x16 devices.
  3. DQ signals are V<sub>DDQ</sub>.
  4. For x4 and x8 only.

Table 137: I<sub>DD7</sub> Measurement-Loop Pattern<sup>1</sup>

CK_t, CK_c	CKE	Sub-Loop	Cycle Number	Command	CS_n	ACT_n	RAS_n/A16	CAS_n/A15	WE_n/A14	ODT	BG[1:0] <sup>2</sup>	BA[1:0]	A12/BC_n	A[17,13,11]	A[10]/AP	A[9:7]	A[6:3]	A[2:0]	Data <sup>3</sup>			
Toggling	Static High	0	0	ACT	0	0	0	0	0	0	0	0	0	0	0	0	0	0	0	-		
			1	RDA	0	1	1	0	1	0	0	0	0	0	0	1	0	0	0	0		
			2	D	1	0	0	0	0	0	0	0	0	0	0	0	0	0	0	0	-	
			3	D_n	1	1	1	1	1	1	0	3	3	0	0	0	7	F	0	0	-	
		... Repeat pattern 2...3 until nRRD - 1, if nRRD > 4. Truncate if necessary																				
		1	nRRD	ACT	0	0	0	0	0	0	0	1	1	0	0	0	0	0	0	0	0	-
			nRRD+1	RDA	0	1	1	0	1	0	1	1	1	0	0	1	0	0	0	0	0	
			... Repeat pattern 2...3 until 2 × nRRD - 1, if nRRD > 4. Truncate if necessary																			
		2	2 × nRRD	Repeat sub-loop 0, use BG[1:0] = 0, use BA[1:0] = 2 instead																		
		3	3 × nRRD	Repeat sub-loop 1, use BG[1:0] = 1, use BA[1:0] = 3 instead																		
		4	4 × nRRD	Repeat pattern 2...3 until nFAW - 1, if nFAW > 4 × nRRD. Truncate if necessary																		
		5	nFAW	Repeat sub-loop 0, use BG[1:0] = 0, use BA[1:0] = 1 instead																		
		6	nFAW + nRRD	Repeat sub-loop 1, use BG[1:0] = 1, use BA[1:0] = 2 instead																		
		7	nFAW + 2 × nRRD	Repeat sub-loop 0, use BG[1:0] = 0, use BA[1:0] = 3 instead																		
		8	nFAW + 3 × nRRD	Repeat sub-loop 1, use BG[1:0] = 1, use BA[1:0] = 0 instead																		
		9	nFAW + 4 × nRRD	Repeat sub-loop 4																		
		10	2 × nFAW	Repeat sub-loop 0, use BG[1:0] = 2, use BA[1:0] = 0 instead																		
		11	2 × nFAW + nRRD	Repeat sub-loop 1, use BG[1:0] = 3, use BA[1:0] = 1 instead																		
		12	2 × nFAW + 2 × nRRD	Repeat sub-loop 0, use BG[1:0] = 2, use BA[1:0] = 2 instead																		
		13	2 × nFAW + 3 × nRRD	Repeat sub-loop 1, use BG[1:0] = 3, use BA[1:0] = 3 instead																		
14	2 × nFAW + 4 × nRRD	Repeat sub-loop 4																				
15	3 × nFAW	Repeat sub-loop 0, use BG[1:0] = 2, use BA[1:0] = 1 instead																				
16	3 × nFAW + nRRD	Repeat sub-loop 1, use BG[1:0] = 3, use BA[1:0] = 2 instead																				
17	3 × nFAW + 2 × nRRD	Repeat sub-loop 0, use BG[1:0] = 2, use BA[1:0] = 3 instead																				
18	3 × nFAW + 3 × nRRD	Repeat sub-loop 1, use BG[1:0] = 3, use BA[1:0] = 0 instead																				
19	3 × nFAW + 4 × nRRD	Repeat sub-loop 4																				
20	4 × nFAW	Repeat pattern 2...3 until nRC - 1, if nRC > 4 × nFAW. Truncate if necessary																				

- Notes: 1. DQS\_t, DQS\_c are V<sub>DDQ</sub>.  
 2. BG1 is a "Don't Care" for x16 devices.  
 3. DQ signals are V<sub>DDQ</sub> except when burst sequence drives each DQ signal by a READ command.



4. For x4 and x8 only.

## I<sub>DD</sub> Specifications

Table 138: Timings used for I<sub>DD</sub>, I<sub>PP</sub>, and I<sub>DDQ</sub> Measurement-Loop Patterns

Symbol	DDR4-1600			DDR4-1866			DDR4-2133			DDR4-2400			DDR4-2666			DDR4-3200			Unit	
	10-10-10	11-11-11	12-12-12	12-12-12	13-13-13	14-14-14	14-14-14	15-15-15	16-16-16	15-15-15	16-16-16	17-17-17	17-17-17	18-18-18	19-19-19	20-20-20	22-22-22	24-24-24		
t <sub>CK</sub>	1.25			1.071			0.937			0.833			0.75			0.625			ns	
CL	10	11	12	12	13	14	14	15	16	15	16	17	17	18	19	20	22	24	CK	
CWL	9	11	11	10	12	12	11	14	14	12	16	16	14	18	18	16	20	20	CK	
nRCD	10	11	12	12	13	14	14	15	16	15	16	17	17	18	19	20	22	24	CK	
nRC	38	39	40	44	45	46	50	51	52	54	55	57	60	61	62	72	74	76	CK	
nRP	10	11	12	12	13	14	14	15	16	15	16	17	17	18	19	20	22	24	CK	
nRAS	28			32			36			39			43			52			CK	
nFAW	x4 <sup>1</sup>	16			16			16			16			16			16			CK
	x8	20			22			23			26			28			34			CK
	x16	28			28			32			36			40			48			CK
nRRD <sub>S</sub>	x4	4			4			4			4			4			4			CK
	x8	4			4			4			4			4			4			CK
	x16	5			5			6			7			7			9			CK
nRRD <sub>L</sub>	x4	5			5			6			6			7			8			CK
	x8	5			5			6			6			7			8			CK
	x16	6			6			7			8			9			11			CK
nCCD <sub>S</sub>	4			4			4			4			4			4			CK	
nCCD <sub>L</sub>	5			5			6			6			7			8			CK	
nWTR <sub>S</sub>	2			3			3			3			4			4			CK	
nWTR <sub>L</sub>	6			7			8			9			10			12			CK	
nRFC 2Gb	128			150			171			193			214			256			CK	
nRFC 4Gb	208			243			278			313			347			416			CK	
nRFC 8Gb	280			327			374			421			467			560			CK	
nRFC 16Gb	440			514			587			660			733			880			CK	

Note: 1. 1KB based x4 use same numbers of clocks for nFAW as the x8.

## Current Specifications – Limits

**Table 139: I<sub>DD</sub>, I<sub>PP</sub>, and I<sub>DDQ</sub> Current Limits – Rev. A**

Symbol	Width	DDR4-1600	DDR4-1866	DDR4-2133	DDR4-2400	Unit
I <sub>DD0</sub> : One bank ACTIVATE-to-PRE-CHARGE current	x4, x8	58	58	60	64	mA
	x16	66	66	68	70	mA
I <sub>PP0</sub> : One bank ACTIVATE-to-PRECHARGE I <sub>PP</sub> current	x4, x8	4	4	4	4	mA
	x16	4.6	4.6	4.6	4.6	mA
I <sub>DD1</sub> : One bank ACTIVATE-to-READ-to-PRECHARGE current	x4, x8	63	63	65	68	mA
	x16	78	78	80	83	mA
I <sub>DD2N</sub> : Precharge standby current	ALL	44	44	46	50	mA
I <sub>DD2NT</sub> : Precharge standby ODT current	x4, x8	50	50	54	58	mA
	x16	60	60	64	68	mA
I <sub>DD2P</sub> : Precharge power-down current	ALL	30	30	30	32	mA
I <sub>DD2Q</sub> : Precharge quiet standby current	ALL	39	39	39	41	mA
I <sub>DD3N</sub> : Active standby current	ALL	61	61	63	67	mA
I <sub>PP3N</sub> : Active standby I <sub>PP</sub> current	ALL	3	3	3	3	mA
I <sub>DD3P</sub> : Active power-down current	ALL	44	44	44	44	mA
I <sub>DD4R</sub> : Burst read current	x4, x8	140	140	150	160	mA
	x16	200	200	215	230	mA
I <sub>DD4W</sub> : Burst write current	x4, x8	156	156	176	196	mA
	x16	246	246	276	314	mA
I <sub>DD5B</sub> : Burst refresh current (1X REF)	x4, x8	190	190	190	192	mA
	x16	190	190	190	192	mA
I <sub>PP5B</sub> : Burst refresh I <sub>PP</sub> current (1X REF)	x4, x8	22	22	22	22	mA
	x16	22	22	22	22	mA
I <sub>DD6N</sub> : Self refresh current; 0–85°C <sup>1</sup>	ALL	20	20	20	20	mA
I <sub>DD6E</sub> : Self refresh current; 0–95°C <sup>2</sup>	ALL	27	27	27	27	mA
I <sub>DD6R</sub> : Self refresh current; 0–45°C <sup>3, 4</sup>	ALL	10	10	10	10	mA
I <sub>DD6A</sub> : Auto self refresh current (25°C) <sup>4</sup>	ALL	9	9	9	9	mA
I <sub>DD6A</sub> : Auto self refresh current (45°C) <sup>4</sup>	ALL	10	10	10	10	mA
I <sub>DD6A</sub> : Auto self refresh current (75°C) <sup>4</sup>	ALL	16	16	16	16	mA
I <sub>DD7</sub> : Bank interleave read current	x4, x8	160	160	185	210	mA
	x16	230	230	240	250	mA
I <sub>PP7</sub> : Bank interleave read I <sub>PP</sub> current	x4, x8	10	10	12	14	mA
	x16	12	12	14	16	mA
I <sub>DD8</sub> : Maximum power-down current	ALL	18	18	18	18	mA

- Notes: 1. Applicable for MR2 settings A7 = 0 and A6 = 0; manual mode with normal temperature range of operation (0–85°C).  
2. Applicable for MR2 settings A7 = 1 and A7 = 0; manual mode with extended temperature range of operation (0–95°C).

3. Applicable for MR2 settings A7 = 0 and A7 = 1; manual mode with reduced temperature range of operation (0–45°C).
4.  $I_{DD6R}$  and  $I_{DD6A}$  values are typical.
5. When additive latency is enabled for  $I_{DD0}$ , current changes by approximately 0%.
6. When additive latency is enabled for  $I_{DD1}$ , current changes by approximately +5% (x4/x8), +4% (x16).
7. When additive latency is enabled for  $I_{DD2N}$ , current changes by approximately +0.6%.
8. When DLL is disabled for  $I_{DD2N}$ , current changes by approximately 0%.
9. When CAL is enabled for  $I_{DD2N}$ , current changes by approximately –44%.
10. When gear-down is enabled for  $I_{DD2N}$ , current changes by approximately 0%.
11. When CA parity is enabled for  $I_{DD2N}$ , current changes by approximately +14%.
12. When additive latency is enabled for  $I_{DD3N}$ , current changes by approximately +0.6%.
13. When additive latency is enabled for  $I_{DD4R}$ , current changes by approximately +5%.
14. When read DBI is enabled for  $I_{DD4R}$ , current changes by approximately 0%.
15. When read DBI is enabled for  $I_{DDQ4R}$ , current changes by approximately –48% (x4/8), –35% (x16).
16. When additive latency is enabled for  $I_{DD4W}$ , current changes by approximately +1.6% (x4/8), +1% (x16).
17. When write DBI is enabled for  $I_{DD4W}$ , current changes by approximately 0%.
18. When write CRC is enabled for  $I_{DD4W}$ , current changes by approximately –8% (2133/2400), –5% (1600/1866).
19. When CA parity is enabled for  $I_{DD4W}$ , current changes by approximately +14% (x8), +8% (x16).
20. When 2X REF is enabled for  $I_{DD5B}$ , current changes by approximately –14%.
21. When 4X REF is enabled for  $I_{DD5B}$ , current changes by approximately –33%.
22.  $I_{PP0}$  test and limit is applicable for  $I_{DD0}$  and  $I_{DD1}$  conditions.
23.  $I_{PP3N}$  test and limit is applicable for all  $I_{DD2x}$ ,  $I_{DD3x}$ ,  $I_{DD4x}$ ,  $I_{DD6}$ , and  $I_{DD8}$  conditions; that is, testing  $I_{PP3N}$  should satisfy the  $I_{PPs}$  for the noted  $I_{DD}$  tests.

**Table 140:  $I_{DD}$ ,  $I_{PP}$ , and  $I_{DDQ}$  Current Limits – Rev. B**

Symbol	Width	DDR4-1866	DDR4-2133	DDR4-2400	DDR4-2666	Unit
$I_{DD0}$ : One bank ACTIVATE-to-PRECHARGE current	x4, x8	50	55	60	65	mA
	x16	60	65	65	70	
$I_{PP0}$ : One bank ACTIVATE-to-PRECHARGE $I_{PP}$ current	x4, x8	3	3	3	3	mA
	x16	3.6	3.6	3.6	3.6	
$I_{DD1}$ : One bank ACTIVATE-to-READ-to-PRECHARGE current	x4, x8	55	60	65	70	mA
	x16	70	75	75	80	
$I_{DD2N}$ : Precharge standby current	ALL	40	42	45	50	mA
$I_{DD2NT}$ : Precharge standby ODT current	x4, x8	45	50	50	55	mA
	x16	55	60	60	70	
$I_{DD2P}$ : Precharge power-down current	ALL	27	27	29	34	mA
$I_{DD2Q}$ : Precharge quiet standby current	ALL	35	35	37	40	mA
$I_{DD3N}$ : Active standby current	ALL	55	55	60	65	mA
$I_{PP3N}$ : Active standby $I_{PP}$ current	ALL	3	3	3	3	mA
$I_{DD3P}$ : Active power-down current	ALL	40	40	40	40	mA

**Table 140: I<sub>DD</sub>, I<sub>pp</sub>, and I<sub>DDQ</sub> Current Limits – Rev. B (Continued)**

Symbol	Width	DDR4-1866	DDR4-2133	DDR4-2400	DDR4-2666	Unit
I <sub>DD4R</sub> : Burst read current	x4, x8	125	135	145	170	mA
	x16	180	195	205	225	mA
I <sub>DD4W</sub> : Burst write current	x4, x8	140	155	175	195	mA
	x16	220	250	285	310	mA
I <sub>DD5B</sub> : Burst refresh current (1X REF)	x4, x8	170	170	175	175	mA
	x16	170	170	175	175	mA
I <sub>pp5B</sub> : Burst refresh I <sub>pp</sub> current (1X REF)	x4, x8	22	22	22	22	mA
	x16	25	25	25	25	mA
I <sub>DD6N</sub> : Self refresh current; 0–85°C <sup>1</sup>	ALL	18	18	18	18	mA
I <sub>DD6E</sub> : Self refresh current; 0–95°C <sup>2</sup>	ALL	24	24	24	24	mA
I <sub>DD6R</sub> : Self refresh current; 0–45°C <sup>3, 4</sup>	ALL	12	12	12	12	mA
I <sub>DD6A</sub> : Auto self refresh current (25°C) <sup>4</sup>	ALL	9	9	9	9	mA
I <sub>DD6A</sub> : Auto self refresh current (45°C) <sup>4</sup>	ALL	12	12	12	12	mA
I <sub>DD6A</sub> : Auto self refresh current (75°C) <sup>4</sup>	ALL	18	18	18	18	mA
I <sub>DD7</sub> : Bank interleave read current	x4, x8	145	165	190	200	mA
	x16	205	215	225	235	mA
I <sub>pp7</sub> : Bank interleave read I <sub>pp</sub> current	x4, x8	10	12	14	16	mA
	x16	12	14	16	16	mA
I <sub>DD8</sub> : Maximum power-down current	ALL	16	16	16	16	mA

- Notes:
1. Applicable for MR2 settings A7 = 0 and A6 = 0; manual mode with normal temperature range of operation (0–85°C).
  2. Applicable for MR2 settings A7 = 1 and A7 = 0; manual mode with extended temperature range of operation (0–95°C).
  3. Applicable for MR2 settings A7 = 0 and A7 = 1; manual mode with reduced temperature range of operation (0–45°C).
  4. I<sub>DD6R</sub> and I<sub>DD6A</sub> values are typical.
  5. When additive latency is enabled for I<sub>DD0</sub>, current changes by approximately 0%.
  6. When additive latency is enabled for I<sub>DD1</sub>, current changes by approximately +5% (x4/x8), +4% (x16).
  7. When additive latency is enabled for I<sub>DD2N</sub>, current changes by approximately +0.6%.
  8. When DLL is disabled for I<sub>DD2N</sub>, current changes by approximately 0%.
  9. When CAL is enabled for I<sub>DD2N</sub>, current changes by approximately –44%.
  10. When gear-down is enabled for I<sub>DD2N</sub>, current changes by approximately 0%.
  11. When CA parity is enabled for I<sub>DD2N</sub>, current changes by approximately +14%.
  12. When additive latency is enabled for I<sub>DD3N</sub>, current changes by approximately +0.6%.
  13. When additive latency is enabled for I<sub>DD4R</sub>, current changes by approximately +5%.
  14. When read DBI is enabled for I<sub>DD4R</sub>, current changes by approximately 0%.
  15. When read DBI is enabled for I<sub>DDQ4R</sub>, current changes by approximately –48% (x4/8), –35% (x16).
  16. When additive latency is enabled for I<sub>DD4W</sub>, current changes by approximately +1.6% (x4/8), +1% (x16).

17. When write DBI is enabled for  $I_{DD4W}$ , current changes by approximately 0%.
18. When write CRC is enabled for  $I_{DD4W}$ , current changes by approximately -8% (2133/2400), -5% (1600/1866).
19. When CA parity is enabled for  $I_{DD4W}$ , current changes by approximately +14% (x8), +8% (x16).
20. When 2X REF is enabled for  $I_{DD5B}$ , current changes by approximately -14%.
21. When 4X REF is enabled for  $I_{DD5B}$ , current changes by approximately -33%.
22.  $I_{PP0}$  test and limit is applicable for  $I_{DD0}$  and  $I_{DD1}$  conditions.
23.  $I_{PP3N}$  test and limit is applicable for all  $I_{DD2x}$ ,  $I_{DD3x}$ ,  $I_{DD4x}$ ,  $I_{DD6}$ , and  $I_{DD8}$  conditions; that is, testing  $I_{PP3N}$  should satisfy the  $I_{PPS}$  for the noted  $I_{DD}$  tests.

## Speed Bin Tables

**Table 141: DDR4-1600 Speed Bins and Operating Conditions**

DDR4-1600 Speed Bin			-125F		-125E		-125		Unit	
CL-nRCD-nRP			10-10-10		11-11-11		12-12-12			
Parameter	Symbol		Min	Max	Min	Max	Min	Max		
Internal READ command to first data	$t_{AA}$		12.50	18.00	13.75 <sup>5</sup>	18.00	15.00	18.00	ns	
Internal READ command to first data with read DBI enabled	$t_{AA\_DBI}$		$t_{AA}$ (MIN) + $2nCK$	–	$t_{AA}$ (MIN) + $2nCK$	–	–	$t_{AA}$ (MAX) + $2nCK$	ns	
ACTIVATE to internal READ or WRITE delay time	$t_{RCD}$		12.50	–	13.75 <sup>5</sup>	–	15.00	–	ns	
PRECHARGE command period	$t_{RP}$		12.50	–	13.75 <sup>5</sup>	–	15.00	–	ns	
ACTIVATE-to-PRECHARGE command period	$t_{RAS}$		35	$9 \times t_{REFI}$	35	$9 \times t_{REFI}$	35	$9 \times t_{REFI}$	ns	
ACTIVATE-to-ACTIVATE or REFRESH command period	$t_{RC}$		$t_{RAS} + t_{RP}$	–	$t_{RAS} + t_{RP}$	–	$t_{RAS} + t_{RP}$	–	ns	
READ: non-DBI	READ: DBI	WRITE	Symbol	Min	Max	Min	Max	Min	Max	Unit
CL = 9	CL = 11	CWL = 9	$t_{CK}^4$	1.5	1.9	1.5	1.9	Reserved		ns
CL = 10	CL = 12	CWL = 9	$t_{CK}^4$	1.5	1.6	Reserved		1.5	1.6	ns
CL = 10	CL = 12	CWL = 9, 11	$t_{CK}^4$	1.25	<1.5	Reserved		Reserved		ns
CL = 11	CL = 13	CWL = 9, 11	$t_{CK}^4$	1.25	<1.5	1.25	<1.5	Reserved		ns
CL = 12	CL = 14	CWL = 9, 11	$t_{CK}^4$	1.25	<1.5	1.25	<1.5	1.25	<1.5	ns
Supported CL settings				9–12		9, 11, 12		10, 12		nCK
Supported CL settings with read DBI				11–14		11, 13, 14		12, 14		nCK
Supported CWL settings				9, 11		9, 11		9, 11		nCK

- Notes:
- Speed Bin table is only valid with DLL enabled and gear-down mode disabled.
  - When operating in  $2t_{CK}$  WRITE preamble mode, CWL must be programmed to a value at least 1 clock greater than the lowest CWL setting supported in the applicable  $t_{CK}$  range.
  - The programmed value of CWL must be less than or equal to programmed value of CL.
  - $t_{CK}^{(AVG)}$  MIN.
  - The DRAM supports 13.5ns with CL9 operation at defined clock rates.

**Table 142: DDR4-1866 Speed Bins and Operating Conditions**

DDR4-1866 Speed Bin			-107F		-107E		-107		Unit	
CL-nRCD-nRP			12-12-12		13-13-13		14-14-14			
Parameter	Symbol		Min	Max	Min	Max	Min	Max		
Internal READ command to first data	$t_{AA}$		12.85	18.00	13.92 <sup>7</sup>	18.00	15.00	18.00	ns	
Internal READ command to first data with read DBI enabled	$t_{AA\_DBI}$		$t_{AA}$ (MIN) + $2nCK$	–	$t_{AA}$ (MIN) + $2nCK$	–	$t_{AA}$ (MIN) + $2nCK$	–	ns	
ACTIVATE to internal READ or WRITE delay time	$t_{RCD}$		12.85	–	13.92 <sup>7</sup>	–	15.00	–	ns	
PRECHARGE command period	$t_{RP}$		12.85	–	13.92 <sup>7</sup>	–	15.00	–	ns	
ACTIVATE-to-PRECHARGE command period	$t_{RAS}$		34	$9 \times t_{REFI}$	34	$9 \times t_{REFI}$	34	$9 \times t_{REFI}$	ns	
ACTIVATE-to-ACTIVATE or REFRESH command period	$t_{RC}$		$t_{RAS} + t_{RP}$	–	$t_{RAS} + t_{RP}$	–	$t_{RAS} + t_{RP}$	–	ns	
READ: nonDBI	READ: DBI	WRITE	Symbol	Min	Max	Min	Max	Min	Max	Unit
CL = 9	CL = 11	CWL = 9	$t_{CK}^6$	1.5	1.9	1.5	1.9	Reserved		ns
CL = 10	CL = 12	CWL = 9	$t_{CK}^6$	1.5	1.6	Reserved		1.5	1.6	ns
CL = 10	CL = 12	CWL = 11	$t_{CK}^6$	Reserved		Reserved		Reserved		ns
CL = 11	CL = 13	CWL = 9, 11	$t_{CK}^6$	Reserved		1.25	<1.5	Reserved		ns
CL = 12	CL = 14	CWL = 9, 11	$t_{CK}^6$	1.25	<1.5	1.25	<1.5	1.25	<1.5	ns
CL = 12	CL = 14	CWL = 10, 12	$t_{CK}^6$	1.071	<1.25	Reserved		Reserved		ns
CL = 13	CL = 15	CWL = 10, 12	$t_{CK}^6$	1.071	<1.25	1.071	<1.25	Reserved		ns
CL = 14	CL = 16	CWL = 10, 12	$t_{CK}^6$	1.071	<1.25	1.071	<1.25	1.071	<1.25	ns
Supported CL settings				9, 10, 12–14		9, 11–14		10, 12, 14		nCK
Supported CL settings with read DBI				11,12,14-16		11, 13–16		12, 14, 16		nCK
Supported CWL settings				9–12		9–12		9–12		nCK

- Notes:
- Speed Bin table is only valid with DLL enabled and gear-down mode disabled.
  - When operating in  $2t_{CK}$  WRITE preamble mode, CWL must be programmed to a value at least 1 clock greater than the lowest CWL setting supported in the applicable  $t_{CK}$  range.
  - The programmed value of CWL must be less than or equal to programmed value of CL.
  - 12.85ns is the minimum value of  $t_{AA}$  and  $t_{RP}$  when operating at DDR4-1866 at  $t_{CK}(AVG)$  MIN = 1.071ns and is only a reference that does not consider the down binning strategy that 12.5ns supports.
  - 13.92ns is the minimum value of  $t_{AA}$  and  $t_{RP}$  when operating at DDR4-1866 at  $t_{CK}(AVG)$  MIN = 1.071ns and is only a reference that does not consider the down binning strategy that 13.75ns supports.
  - $t_{CK}(AVG)$  MIN.
  - The DRAM supports 13.5ns with CL9 operation and 13.75ns with CL11 operation at defined clock rates.

**Table 143: DDR4-2133 Speed Bins and Operating Conditions**

DDR4-2133 Speed Bin			-093F		-093E		-093		Unit	
CL-nRCD-nRP			14-14-14		15-15-15		16-16-16			
Parameter	Symbol		Min	Max	Min	Max	Min	Max		
Internal READ command to first data	$t_{AA}$		13.13	18.00	14.06 <sup>5</sup>	18.00	15.00	18.00	ns	
Internal READ command to first data with read DBI enabled	$t_{AA\_DBI}$		$t_{AA(MIN)} + 3nCK$	–	$t_{AA(MIN)} + 3nCK$	–	$t_{AA(MIN)} + 3nCK$	–	ns	
ACTIVATE to internal READ or WRITE delay time	$t_{RCD}$		13.13	–	14.06 <sup>5</sup>	–	15.00	–	ns	
PRECHARGE command period	$t_{RP}$		13.13	–	14.06 <sup>5</sup>	–	15.00	–	ns	
ACTIVATE-to-PRECHARGE command period	$t_{RAS}$		33	$9 \times t_{REFI}$	33	$9 \times t_{REFI}$	33	$9 \times t_{REFI}$	ns	
ACTIVATE-to-ACTIVATE or REFRESH command period	$t_{RC}$		$t_{RAS} + t_{RP}$	–	$t_{RAS} + t_{RP}$	–	$t_{RAS} + t_{RP}$	–	ns	
READ: nonDBI	READ: DBI	WRITE	Symbol	Min	Max	Min	Max	Min	Max	Unit
CL = 9	CL = 11	CWL = 9	$t_{CK}^4$	1.5	1.9	1.5	1.9	Reserved		ns
CL = 10	CL = 12	CWL = 9	$t_{CK}^4$	1.5	1.6	Reserved		1.5	1.6	
CL = 11	CL = 13	CWL = 9, 11	$t_{CK}^4$	Reserved		1.25	<1.5	Reserved		ns
CL = 12	CL = 14	CWL = 9, 11	$t_{CK}^4$	1.25	<1.5	1.25	<1.5	1.25	<1.5	ns
CL = 13	CL = 15	CWL = 10, 12	$t_{CK}^4$	Reserved		1.071	<1.25	Reserved		ns
CL = 14	CL = 16	CWL = 10, 12	$t_{CK}^4$	1.071	<1.25	1.071	<1.25	1.071	<1.25	ns
CL = 14	CL = 17	CWL = 11, 14	$t_{CK}^4$	0.937 <sup>6</sup>	<1.071	Reserved		Reserved		ns
CL = 15	CL = 18	CWL = 11, 14	$t_{CK}^4$	0.937	<1.071	0.937	<1.071	Reserved		ns
CL = 16	CL = 19	CWL = 11, 14	$t_{CK}^4$	0.937	<1.071	0.937	<1.071	0.937	<1.071	ns
Supported CL settings				9, 10, 12, 14–16		9, 11–16		10, 12, 14, 16		nCK
Supported CL settings with read DBI				11, 12, 14, 16–19		11, 13–16, 18, 19		12, 14, 16, 19		nCK
Supported CWL settings				9, 10, 11, 12, 14		9, 10, 11, 12, 14		9, 10, 11, 12, 14		nCK

- Notes:
- Speed Bin table is only valid with DLL enabled and gear-down mode disabled.
  - When operating in  $2t_{CK}$  WRITE preamble mode, CWL must be programmed to a value at least 1 clock greater than the lowest CWL setting supported in the applicable  $t_{CK}$  range.
  - The programmed value of CWL must be less than or equal to programmed value of CL.
  - $t_{CK(AVG)}$  MIN.
  - The DRAM supports 13.5ns with CL9 operation and 13.75ns with CL11 operation 13.92ns with CL13 operation at defined clock rates.
  - If the clock period is less than 0.938ns and greater than or equal to 0.937ns, timing parameters that are derived off the clock will use 0.938ns as its reference. For example, if  $t_{CK(MIN)} = 0.938ns$  and  $t_{RP} = 14.06ns$ , then  $t_{RP}$  would require 15nCKs ( $14.06ns / 0.938ns$ ), but if  $t_{CK(MIN)} = 0.937ns$  and  $t_{RP} = 14.06ns$ , then  $t_{RP}$  would still require 15nCKs ( $14.06ns / 0.938ns$ ) and not 16nCKs ( $14.06ns / 0.937ns$ ).

**Table 144: DDR4-2400 Speed Bins and Operating Conditions**

DDR4-2400 Speed Bin				-083F		-083E		-083		Unit
CL-nRCD-nRP				15-15-15		16-16-16		17-17-17		
Parameter			Symbol	Min	Max	Min	Max	Min	Max	Unit
Internal READ command to first data			$t_{AA}$	12.5	18.00	13.32	18.00	14.16	18.00	ns
Internal READ command to first data with read DBI enabled			$t_{AA\_DBI}$	$t_{AA(MIN)} + 3nCK$	–	$t_{AA(MIN)} + 3nCK$	–	$t_{AA(MIN)} + 3nCK$	–	ns
ACTIVATE to internal READ or WRITE delay time			$t_{RCD}$	12.5	–	13.32	–	14.16	–	ns
PRECHARGE command period			$t_{RP}$	12.5	–	13.32	–	14.16	–	ns
ACTIVATE-to-PRECHARGE command period			$t_{RAS}$	32	$9 \times t_{REFI}$	32	$9 \times t_{REFI}$	32	$9 \times t_{REFI}$	ns
ACTIVATE-to-ACTIVATE or REFRESH command period			$t_{RC}$	$t_{RAS} + t_{RP}$	–	$t_{RAS} + t_{RP}$	–	$t_{RAS} + t_{RP}$	–	ns
READ: nonDBI	READ: DBI	WRITE	Symbol	Min	Max	Min	Max	Min	Max	Unit
CL = 9	CL = 11	CWL = 9	$t_{CK}^4$	1.5	1.9	1.5	1.9	Reserved		ns
CL = 10	CL = 12	CWL = 9	$t_{CK}^4$	1.5	1.6	Reserved		1.5	1.6	ns
CL = 10	CL = 12	CWL = 9, 11	$t_{CK}^4$	Reserved		Reserved		Reserved		ns
CL = 11	CL = 13	CWL = 9, 11	$t_{CK}^4$	Reserved		1.25	<1.5	1.25	<1.5	ns
CL = 12	CL = 14	CWL = 9, 11	$t_{CK}^4$	1.25	<1.5	1.25	<1.5	1.25	<1.5	ns
CL = 12	CL = 14	CWL = 10, 12	$t_{CK}^4$	Reserved		Reserved		Reserved		ns
CL = 13	CL = 15	CWL = 10, 12	$t_{CK}^4$	Reserved		1.071	<1.25	1.071	<1.25	ns
CL = 14	CL = 16	CWL = 10, 12	$t_{CK}^4$	1.071	<1.25	1.071	<1.25	1.071	<1.25	ns
CL = 14	CL = 17	CWL = 11, 14	$t_{CK}^4$	Reserved		Reserved		Reserved		ns
CL = 15	CL = 18	CWL = 11, 14	$t_{CK}^4$	Reserved		0.937 <sup>5</sup>	<1.071	0.937	<1.071	ns
CL = 16	CL = 19	CWL = 11, 14	$t_{CK}^4$	0.937	<1.071	0.937	<1.071	0.937	<1.071	ns
CL = 15	CL = 18	CWL = 12, 16	$t_{CK}^4$	0.833	<0.937	Reserved		Reserved		ns
CL = 16	CL = 19	CWL = 12, 16	$t_{CK}^4$	0.833	<0.937	0.833	<0.937	Reserved		ns
CL = 17	CL = 20	CWL = 12, 16	$t_{CK}^4$	0.833	<0.937	0.833	<0.937	0.833	<0.937	ns
CL = 18	CL = 21	CWL = 12, 16	$t_{CK}^4$	0.833	<0.937	0.833	<0.937	0.833	<0.937	ns
Supported CL settings				9, 10, 12, 14–18		9, 11–18		10–18		nCK
Supported CL settings with read DBI				11, 12, 14, 16, 18–21		11, 13–16, 18–21		12–16, 18–21		nCK
Supported CWL settings				9, 10, 11, 12, 14, 16		9, 10, 11, 12, 14, 16		9, 10, 11, 12, 14, 16		nCK

- Notes:
- Speed Bin table is only valid with DLL enabled and gear-down mode disabled.
  - When operating in  $2t_{CK}$  WRITE preamble mode, CWL must be programmed to a value at least 1 clock greater than the lowest CWL setting supported in the applicable  $t_{CK}$  range.
  - The programmed value of CWL must be less than or equal to programmed value of CL.
  - $t_{CK(AVG)}$  MIN.
  - If the clock period is less than 0.938ns and greater than or equal to 0.937ns, timing parameters that are derived off the clock will use 0.938ns as its reference. For example, if



## 4Gb: x4, x8, x16 DDR4 SDRAM Speed Bin Tables

$t_{CK} (MIN) = 0.938ns$  and  $t_{RP} = 14.06ns$ , then  $t_{RP}$  would require  $15nCKs$  ( $14.06ns/0.938ns$ ), but if  $t_{CK} (MIN) = 0.937ns$  and  $t_{RP} = 14.06ns$ , then  $t_{RP}$  would still require  $15nCKs$  ( $14.06ns/0.938ns$ ) and not  $16nCKs$  ( $14.06ns/0.937ns$ ).

**Table 145: DDR4-2666 Speed Bins and Operating Conditions**

DDR4-2666 Speed Bin				-075F		-075E		-075		Unit
CL-nRCD-nRP				17-17-17		18-18-18		19-19-19		
Parameter		Symbol		Min	Max	Min	Max	Min	Max	
Internal READ command to first data		$t_{AA}$		12.75	18.00	13.5	18.00	14.25 <sup>5</sup>	18.00	ns
Internal READ command to first data with read DBI enabled		$t_{AA\_DBI}$		$t_{AA}(MIN) + 3nCK$	–	$t_{AA}(MIN) + 3nCK$	–	$t_{AA}(MIN) + 3nCK$	–	ns
ACTIVATE to internal READ or WRITE delay time		$t_{RCD}$		12.75	–	13.5	–	14.16	–	ns
PRECHARGE command period		$t_{RP}$		12.75	–	13.5	–	14.16	–	ns
ACTIVATE-to-PRECHARGE command period		$t_{RAS}$		32	$9 \times t_{REFI}$	32	$9 \times t_{REFI}$	32	$9 \times t_{REFI}$	ns
ACTIVATE-to-ACTIVATE or REFRESH command period		$t_{RC}$		$t_{RAS} + t_{RP}$	–	$t_{RAS} + t_{RP}$	–	$t_{RAS} + t_{RP}$	–	ns
READ: nonDBI	READ: DBI	WRITE	Symbol	Min	Max	Min	Max	Min	Max	Unit
CL = 9	CL = 11	CWL = 9	$t_{CK}^4$	1.5	1.9	1.5	1.9	Reserved		ns
CL = 10	CL = 12	CWL = 9	$t_{CK}^4$	1.5	1.6	1.5	1.6	1.5	1.6	ns
CL = 10	CL = 12	CWL = 9, 11	$t_{CK}^4$	Reserved		Reserved		Reserved		ns
CL = 11	CL = 13	CWL = 9, 11	$t_{CK}^4$	1.25	<1.5	1.25	<1.5	Reserved		ns
CL = 12	CL = 14	CWL = 9, 11	$t_{CK}^4$	1.25	<1.5	1.25	<1.5	1.25	<1.5	ns
CL = 12	CL = 14	CWL = 10, 12	$t_{CK}^4$	Reserved		Reserved		Reserved		ns
CL = 13	CL = 15	CWL = 10, 12	$t_{CK}^4$	1.071	<1.25	1.071	<1.25	1.071	<1.25	ns
CL = 14	CL = 16	CWL = 10, 12	$t_{CK}^4$	1.071	<1.25	1.071	<1.25	1.071	<1.25	ns
CL = 14	CL = 17	CWL = 11, 14	$t_{CK}^4$	Reserved		Reserved		Reserved		ns
CL = 15	CL = 18	CWL = 11, 14	$t_{CK}^4$	0.937 <sup>6</sup>	<1.071	0.937	<1.071	0.937	<1.071	ns
CL = 16	CL = 19	CWL = 11, 14	$t_{CK}^4$	0.937	<1.071	0.937	<1.071	0.937	<1.071	ns
CL = 15	CL = 18	CWL = 12, 16	$t_{CK}^4$	Reserved		Reserved		Reserved		ns
CL = 16	CL = 19	CWL = 12, 16	$t_{CK}^4$	0.833	<0.937	Reserved		Reserved		ns
CL = 17	CL = 20	CWL = 12, 16	$t_{CK}^4$	0.833	<0.937	0.833	<0.937	0.833	<0.937	ns
CL = 18	CL = 21	CWL = 12, 16	$t_{CK}^4$	0.833	<0.937	0.833	<0.937	0.833	<0.937	ns
CL = 17	CL = 20	CWL = 14, 18	$t_{CK}^4$	0.750	<0.833	Reserved		Reserved		ns
CL = 18	CL = 21	CWL = 14, 18	$t_{CK}^4$	0.750	<0.833	0.750	<0.833	Reserved		ns
CL = 19	CL = 22	CWL = 14, 18	$t_{CK}^4$	0.750	<0.833	0.750	<0.833	0.750	<0.833	ns
CL = 20	CL = 23	CWL = 14, 18	$t_{CK}^4$	0.750	<0.833	0.750	<0.833	0.750	<0.833	ns
Supported CL settings				9–20		9–20		10,12–20		nCK
Supported CL settings with read DBI				11, 12, 14–16, 18–23		11, 12, 14–16, 18–23		12, 14–16, 18–23		nCK

**Table 145: DDR4-2666 Speed Bins and Operating Conditions (Continued)**

DDR4-2666 Speed Bin			-075F		-075E		-075		Unit
CL-nRCD-nRP			17-17-17		18-18-18		19-19-19		
Parameter	Symbol		Min	Max	Min	Max	Min	Max	
Supported CWL settings			9, 10, 11, 12, 14, 16, 18		9, 10, 11, 12, 14, 16, 18		9, 10, 11, 12, 14, 16, 18		nCK

- Notes:
- Speed Bin table is only valid with DLL enabled and gear-down mode disabled.
  - When operating in 2<sup>t</sup>CK WRITE preamble mode, CWL must be programmed to a value at least 1 clock greater than the lowest CWL setting supported in the applicable <sup>t</sup>CK range.
  - The programmed value of CWL must be less than or equal to programmed value of CL.
  - <sup>t</sup>CK(AVG) MIN.
  - The DRAM supports 13.92ns with CL13 operation, 14.07ns with CL15 operation, and 14.16ns with CL17 operation at defined clock rates.
  - If the clock period is less than 0.938ns and greater than or equal to 0.937ns, timing parameters that are derived off the clock will use 0.938ns as its reference. For example, if <sup>t</sup>CK (MIN) = 0.938ns and <sup>t</sup>RP = 14.06ns, then <sup>t</sup>RP would require 15nCKs (14.06ns/ 0.938ns), but if <sup>t</sup>CK (MIN) = 0.937ns and <sup>t</sup>RP = 14.06ns, then <sup>t</sup>RP would still require 15nCKs (14.06ns/ 0.938ns) and not 16nCKs (14.06ns/ 0.937ns).

**Table 146: DDR4-2933 Speed Bins and Operating Conditions**

DDR4-2933 Speed Bin			-068E		-068		-068D		Unit	
CL-nRCD-nRP			20-20-20		21-21-21		22-22-22			
Parameter	Symbol		Min	Max	Min	Max	Min	Max		
Internal READ command to first data	<sup>t</sup> AA		13.64 <sup>5</sup>	18.00	14.32 <sup>5</sup>	18.00	15	18.00	ns	
Internal READ command to first data with read DBI enabled	<sup>t</sup> AA_DBI		<sup>t</sup> AA(MIN) + 4nCK	–	<sup>t</sup> AA(MIN) + 4nCK	–	<sup>t</sup> AA(MIN) + 4nCK	–	ns	
ACTIVATE to internal READ or WRITE delay time	<sup>t</sup> RCD		13.64	–	14.32 <sup>5</sup>	–	15	–	ns	
PRECHARGE command period	<sup>t</sup> RP		13.64	–	14.32 <sup>5</sup>	–	15	–	ns	
ACTIVATE-to-PRECHARGE command period	<sup>t</sup> RAS		32	9 × <sup>t</sup> REFI	32	9 × <sup>t</sup> REFI	32	9 × <sup>t</sup> REFI	ns	
ACTIVATE-to-ACTIVATE or REFRESH command period	<sup>t</sup> RC		<sup>t</sup> RAS + <sup>t</sup> RP	–	<sup>t</sup> RAS + <sup>t</sup> RP	–	<sup>t</sup> RAS + <sup>t</sup> RP	–	ns	
READ: nonDBI	READ: DBI	WRITE	Symbol	Min	Max	Min	Max	Min	Max	Unit
CL = 9	CL = 11	CWL = 9	<sup>t</sup> CK <sup>4</sup>	1.5	1.9	Reserved		Reserved		ns
CL = 10	CL = 12	CWL = 9	<sup>t</sup> CK <sup>4</sup>	1.5	1.6	1.5	1.6	1.5	1.6	ns
CL = 10	CL = 12	CWL = 9, 11	<sup>t</sup> CK <sup>4</sup>	Reserved		Reserved		Reserved		ns
CL = 11	CL = 13	CWL = 9, 11	<sup>t</sup> CK <sup>4</sup>	1.25	<1.5	1.25	<1.5	Reserved		ns
CL = 12	CL = 14	CWL = 9, 11	<sup>t</sup> CK <sup>4</sup>	1.25	<1.5	1.25	<1.5	1.25	<1.5	ns
CL = 12	CL = 14	CWL = 10, 12	<sup>t</sup> CK <sup>4</sup>	Reserved		Reserved		Reserved		ns
CL = 13	CL = 15	CWL = 10, 12	<sup>t</sup> CK <sup>4</sup>	1.071	<1.25	1.071	<1.25	Reserved		ns

**Table 146: DDR4-2933 Speed Bins and Operating Conditions (Continued)**

DDR4-2933 Speed Bin			-068E		-068		-068D		Unit	
CL-nRCD-nRP			20-20-20		21-21-21		22-22-22			
Parameter		Symbol	Min	Max	Min	Max	Min	Max		
CL = 14	CL = 16	CWL = 10, 12	$t_{CK}^4$	1.071	<1.25	1.071	<1.25	1.071	<1.25	ns
CL = 14	CL = 17	CWL = 11, 14	$t_{CK}^4$	Reserved		Reserved		Reserved		ns
CL = 15	CL = 18	CWL = 11, 14	$t_{CK}^4$	0.937 <sup>6</sup>	<1.071	0.937	<1.071	Reserved		ns
CL = 16	CL = 19	CWL = 11, 14	$t_{CK}^4$	0.937	<1.071	0.937	<1.071	0.937	<1.071	ns
CL = 15	CL = 18	CWL = 12, 16	$t_{CK}^4$	Reserved		Reserved		Reserved		ns
CL = 16	CL = 19	CWL = 12, 16	$t_{CK}^4$	Reserved		Reserved		Reserved		ns
CL = 17	CL = 20	CWL = 12, 16	$t_{CK}^4$	0.833	<0.937	0.833	<0.937	Reserved		ns
CL = 18	CL = 21	CWL = 12, 16	$t_{CK}^4$	0.833	<0.937	0.833	<0.937	0.833	<0.937	ns
CL = 17	CL = 20	CWL = 14, 18	$t_{CK}^4$	Reserved		Reserved		Reserved		ns
CL = 18	CL = 21	CWL = 14, 18	$t_{CK}^4$	Reserved		Reserved		Reserved		ns
CL = 19	CL = 22	CWL = 14, 18	$t_{CK}^4$	0.750	<0.833	0.750	<0.833	0.750	<0.833	ns
CL = 20	CL = 23	CWL = 14, 18	$t_{CK}^4$	0.750	<0.833	0.750	<0.833	0.750	<0.833	ns
CL = 19	CL = 23	CWL = 16, 20	$t_{CK}^4$	Reserved		Reserved		Reserved		ns
CL = 20	CL = 24	CWL = 16, 20	$t_{CK}^4$	0.682	<0.750	Reserved		Reserved		ns
CL = 21	CL = 26	CWL = 16, 20	$t_{CK}^4$	0.682	<0.750	0.682	<0.750	Reserved		ns
CL = 22	CL = 26	CWL = 16, 20	$t_{CK}^4$	0.682	<0.750	0.682	<0.750	0.682	<0.750	ns
Supported CL settings			9-22		10-22		10, 12, 14, 16, 18, 20		nCK	
Supported CL settings with read DBI			11-24, 26		12-24, 26		12, 14, 16, 19, 21, 23, 26		nCK	
Supported CWL settings			9, 10, 11, 12, 14, 16, 18, 20		9, 10, 11, 12, 14, 15, 16, 18, 20		9, 10, 11, 12, 14, 15, 16, 18, 20		nCK	

- Notes:
1. Speed Bin table is only valid with DLL enabled and gear-down mode disabled.
  2. When operating in 2 $t_{CK}$  WRITE preamble mode, CWL must be programmed to a value at least 1 clock greater than the lowest CWL setting supported in the applicable  $t_{CK}$  range.
  3. The programmed value of CWL must be less than or equal to programmed value of CL.
  4.  $t_{CK}(AVG)$  MIN.
  5. The DRAM supports 13.5ns with CL9 operation.
  6. If the clock period is less than 0.938ns and greater than or equal to 0.937ns, timing parameters that are derived off the clock will use 0.938ns as its reference. For example, if  $t_{CK} (MIN) = 0.938ns$  and  $t_{RP} = 14.06ns$ , then  $t_{RP}$  would require 15nCKs (14.06ns/0.938ns), but if  $t_{CK} (MIN) = 0.937ns$  and  $t_{RP} = 14.06ns$ , then  $t_{RP}$  would still require 15nCKs (14.06ns/0.938ns) and not 16nCKs (14.06ns/0.937ns).



Table 147: DDR4-3200 Speed Bins and Operating Conditions

DDR4-3200 Speed Bin					-062F		-062E		-062		Unit
CL-nRCD-nRP			20-20-20		22-22-22		24-24-24				
Parameter		Symbol	Min	Max	Min	Max	Min	Max	Min	Max	Unit
Internal READ command to first data		$t_{AA}$	12.5	18.00	13.75 <sup>5</sup>	18.00	15	18.00			ns
Internal READ command to first data with read DBI enabled		$t_{AA\_DBI}$	$t_{AA(MIN)} + 4nCK$	–	$t_{AA(MIN)} + 4nCK$	–	$t_{AA(MIN)} + 4nCK$	–			ns
ACTIVATE to internal READ or WRITE delay time		$t_{RCD}$	12.5	–	13.75 <sup>5</sup>	–	15	–			ns
PRECHARGE command period		$t_{RP}$	12.5	–	13.75 <sup>5</sup>	–	15	–			ns
ACTIVATE-to-PRECHARGE command period		$t_{RAS}$	32	$9 \times t_{REFI}$	32	$9 \times t_{REFI}$	32	$9 \times t_{REFI}$			ns
ACTIVATE-to-ACTIVATE or REFRESH command period		$t_{RC}$	$t_{RAS} + t_{RP}$	–	$t_{RAS} + t_{RP}$	–	$t_{RAS} + t_{RP}$	–			ns
READ: nonDBI	READ: DBI	WRITE	Symbol	Min	Max	Min	Max	Min	Max	Unit	
CL = 9	CL = 11	CWL = 9	$t_{CK}^4$	1.5	1.9	Reserved		Reserved		ns	
CL = 10	CL = 12	CWL = 9	$t_{CK}^4$	1.5	1.6	1.5	1.6	1.5	1.6	ns	
CL = 10	CL = 12	CWL = 9, 11	$t_{CK}^4$	Reserved		Reserved		Reserved		ns	
CL = 11	CL = 13	CWL = 9, 11	$t_{CK}^4$	1.25	<1.5	1.25	<1.5	Reserved		ns	
CL = 12	CL = 14	CWL = 9, 11	$t_{CK}^4$	1.25	<1.5	1.25	<1.5	1.25	<1.5	ns	
CL = 12	CL = 14	CWL = 10, 12	$t_{CK}^4$	Reserved		Reserved		Reserved		ns	
CL = 13	CL = 15	CWL = 10, 12	$t_{CK}^4$	1.071	<1.25	1.071	<1.25	Reserved		ns	
CL = 14	CL = 16	CWL = 10, 12	$t_{CK}^4$	1.071	<1.25	1.071	<1.25	1.071	<1.25	ns	
CL = 14	CL = 17	CWL = 11, 14	$t_{CK}^4$	Reserved		Reserved		Reserved		ns	
CL = 15	CL = 18	CWL = 11, 14	$t_{CK}^4$	0.937 <sup>6</sup>	<1.071	0.937	<1.071	Reserved		ns	
CL = 16	CL = 19	CWL = 11, 14	$t_{CK}^4$	0.937	<1.071	0.937	<1.071	0.937	<1.071	ns	
CL = 15	CL = 18	CWL = 12, 16	$t_{CK}^4$	Reserved		Reserved		Reserved		ns	
CL = 16	CL = 19	CWL = 12, 16	$t_{CK}^4$	0.833	<0.937	Reserved		Reserved		ns	
CL = 17	CL = 20	CWL = 12, 16	$t_{CK}^4$	0.833	<0.937	0.833	<0.937	Reserved		ns	
CL = 18	CL = 21	CWL = 12, 16	$t_{CK}^4$	0.833	<0.937	0.833	<0.937	0.833	<0.937	ns	
CL = 17	CL = 20	CWL = 14, 18	$t_{CK}^4$	Reserved		Reserved		Reserved		ns	
CL = 18	CL = 21	CWL = 14, 18	$t_{CK}^4$	0.750	<0.833	0.750	<0.833	Reserved		ns	
CL = 19	CL = 22	CWL = 14, 18	$t_{CK}^4$	0.750	<0.833	0.750	<0.833	0.750	<0.833	ns	
CL = 20	CL = 23	CWL = 14, 18	$t_{CK}^4$	0.750	<0.833	0.750	<0.833	0.750	<0.833	ns	
CL = 20	CL = 24	CWL = 16, 20	$t_{CK}^4$	0.625	<0.750	Reserved		Reserved		ns	
CL = 22	CL = 26	CWL = 16, 20	$t_{CK}^4$	0.625	<0.750	0.625	<0.750	Reserved		ns	
CL = 24	CL = 28	CWL = 16, 20	$t_{CK}^4$	0.625	<0.750	0.625	<0.750	0.625	<0.750	ns	
Supported CL settings			9–20, 22, 24		10–20, 22, 24		9–20, 22, 24				nCK
Supported CL settings with read DBI			11–24, 26, 28		12–16, 18–24, 26, 28		12, 14, 16, 19, 21, 23, 28				nCK

**Table 147: DDR4-3200 Speed Bins and Operating Conditions (Continued)**

DDR4-3200 Speed Bin		-062F		-062E		-062		Unit
CL- <i>n</i> RCD- <i>n</i> RP		20-20-20		22-22-22		24-24-24		
Parameter	Symbol	Min	Max	Min	Max	Min	Max	
Supported CWL settings		9, 10, 11, 12, 14, 16, 18, 20		9, 10, 11, 12, 14, 16, 18, 20		9, 10, 11, 12, 14, 16, 18, 20		<i>n</i> CK

- Notes:
1. Speed Bin table is only valid with DLL enabled and gear-down mode disabled.
  2. When operating in 2<sup>t</sup>CK WRITE preamble mode, CWL must be programmed to a value at least 1 clock greater than the lowest CWL setting supported in the applicable <sup>t</sup>CK range.
  3. The programmed value of CWL must be less than or equal to programmed value of CL.
  4. <sup>t</sup>CK(AVG) MIN.
  5. The DRAM supports 13.5ns with CL9 operation.
  6. If the clock period is less than 0.938ns and greater than or equal to 0.937ns, timing parameters that are derived off the clock will use 0.938ns as its reference. For example, if <sup>t</sup>CK (MIN) = 0.938ns and <sup>t</sup>RP = 14.06ns, then <sup>t</sup>RP would require 15*n*CKs (14.06ns/ 0.938ns), but if <sup>t</sup>CK (MIN) = 0.937ns and <sup>t</sup>RP = 14.06ns, then <sup>t</sup>RP would still require 15*n*CKs (14.06ns/ 0.938ns) and not 16*n*CKs (14.06ns/ 0.937ns).



## Refresh Parameters By Device Density

Table 148: Refresh Parameters by Device Density

Parameter	Symbol	2Gb	4Gb	8Gb	16Gb	Unit	Notes	
REF command to ACT or REF command time	$t_{RFC}$ (All bank groups)	160	260	350	550	ns		
Average periodic refresh interval	$t_{REFI}$	$0^{\circ}\text{C} \leq T_C \leq 85^{\circ}\text{C}$	7.8	7.8	7.8	3.9	$\mu\text{s}$	
		$0^{\circ}\text{C} < T_C \leq 95^{\circ}\text{C}$	3.9	3.9	3.9	1.95	$\mu\text{s}$	1

Note: 1. Users should refer to the DRAM supplier data sheet and/or the DIMM SPD to determine if the devices support these options or requirements.

# Electrical Characteristics and AC Timing Parameters

**Table 149: Electrical Characteristics and AC Timing Parameters: DDR4-1600 through DDR4-2400**

Parameter	Symbol	Clock Timing							
		DDR4-1600		DDR4-1866		DDR4-2133		DDR4-2400	
		Min	Max	Min	Max	Min	Max	Min	Max
Clock period average (DLL off mode)	t <sub>CK (DLL_OFF)</sub>	8	20	8	20	8	20	8	20
Clock period average	t <sub>CK (AVG, DLL_ON)</sub>	1.25	1.6	1.071	1.6	0.937	1.6	0.833	1.6
High pulse width average	t <sub>CH (AVG)</sub>	0.48	0.52	0.48	0.52	0.48	0.52	0.48	0.52
Low pulse width average	t <sub>CL (AVG)</sub>	0.48	0.52	0.48	0.52	0.48	0.52	0.48	0.52
Clock period jitter	Total	-63	63	-54	54	-47	47	-42	42
	Deterministic	-31	31	-27	27	-23	23	-21	21
	DLL locking	-50	50	-43	43	-38	38	-33	33
Clock absolute period	t <sub>CK (ABS)</sub>	MIN = t <sub>CK (AVG)</sub> MIN + t <sub>JITper_tot</sub> MIN; MAX = t <sub>CK (AVG)</sub> MAX + t <sub>JITper_tot</sub> MAX							
Clock absolute high pulse width (includes duty cycle jitter)	t <sub>CH (ABS)</sub>	0.45	-	0.45	-	0.45	-	0.45	-
Clock absolute low pulse width (includes duty cycle jitter)	t <sub>CL (ABS)</sub>	0.45	-	0.45	-	0.45	-	0.45	-
Cycle-to-cycle jitter	Total	125	107	94	83	94	83	94	83
	Deterministic	63	54	47	42	47	42	47	42
	DLL locking	100	86	75	67	75	67	75	67

**Table 149: Electrical Characteristics and AC Timing Parameters: DDR4-1600 through DDR4-2400 (Continued)**

Parameter	Symbol	DDR4-1600		DDR4-1866		DDR4-2133		DDR4-2400	
		Min	Max	Min	Max	Min	Max	Min	Max
Cumulative error across	2 cycles	-92	92	-79	79	-69	69	-61	61
	3 cycles	-109	109	-94	94	-82	82	-73	73
	4 cycles	-121	121	-104	104	-91	91	-81	81
	5 cycles	-131	131	-112	112	-98	98	-87	87
	6 cycles	-139	139	-119	119	-104	104	-92	92
	7 cycles	-145	145	-124	124	-109	109	-97	97
	8 cycles	-151	151	-129	129	-113	113	-101	101
	9 cycles	-156	156	-134	134	-120	120	-104	104
	10 cycles	-160	160	-137	137	-123	123	-107	107
	11 cycles	-164	164	-141	141	-126	126	-110	110
	12 cycles	-168	168	-144	144	-129	129	-112	112
	$n = 13, 14 \dots 49,$ 50 cycles	$t_{ERRnper}$	$t_{ERRnper} \text{ MIN} = (1 + 0.68 \ln[n]) \times t_{JITper} \text{ MIN}$ $t_{ERRnper} \text{ MAX} = (1 + 0.68 \ln[n]) \times t_{JITper} \text{ MAX}$						
DQ Input Timing									
Data setup time to DQS_t, DQS_c	Base (calibrated $V_{REF}$ )	$t_{DS}$	Refer to DQ Input Receiver Specification section (approximately 0.15°C to 0.28°C)						
	Noncalibrated $V_{REF}$	$t_{PDA\_S}$	minimum of 0.5IU						
Data hold time from DQS_t, DQS_c	Base (calibrated $V_{REF}$ )	$t_{DH}$	Refer to DQ Input Receiver Specification section (approximately 0.15°C to 0.28°C)						
	Noncalibrated $V_{REF}$	$t_{PDA\_H}$	minimum of 0.5IU						
DQ and DM minimum data pulse width for each input		$t_{DIPW}$	0.58	-	0.58	-	0.58	-	0.58
DQ Output Timing (DLL enabled)									
DQS_t, DQS_c to DQ skew, per group, per access		$t_{DQSQ}$	-	0.16	-	0.16	-	0.16	-
DQ output hold time from DQS_t, DQS_c		$t_{QH}$	0.76	-	0.76	-	0.76	-	0.74
Data Valid Window per device: $t_{QH} -$ $t_{DQSQ}$ each device's output per UI		$t_{DVW_d}$	0.63		0.63		0.64		0.64
Data Valid Window per device, per pin: $t_{QH} - t_{DQSQ}$ each device's output per UI		$t_{DVW_p}$	0.66	-	0.66	-	0.69	-	0.72

**Table 149: Electrical Characteristics and AC Timing Parameters: DDR4-1600 through DDR4-2400 (Continued)**

Parameter	Symbol	DDR4-1600		DDR4-1866		DDR4-2133		DDR4-2400	
		Min	Max	Min	Max	Min	Max	Min	Max
DQ Low-Z time from CK <sub>t</sub> , CK <sub>c</sub>	<sup>t</sup> LZDQ	-450	225	-390	195	-360	180	-300	150
DQ High-Z time from CK <sub>t</sub> , CK <sub>c</sub>	<sup>t</sup> HZDQ	-	225	-	195	-	180	-	150
<b>DQ Strobe Input Timing</b>									
DQS <sub>t</sub> , DQS <sub>c</sub> rising edge to CK <sub>t</sub> , CK <sub>c</sub> rising edge	<sup>t</sup> DQSS	-0.27	0.27	-0.27	0.27	-0.27	0.27	-0.27	0.27
DQS <sub>t</sub> , DQS <sub>c</sub> differential input low pulse width	<sup>t</sup> DQSL	0.46	0.54	0.46	0.54	0.46	0.54	0.46	0.54
DQS <sub>t</sub> , DQS <sub>c</sub> differential input high pulse width	<sup>t</sup> DQSH	0.46	0.54	0.46	0.54	0.46	0.54	0.46	0.54
DQS <sub>t</sub> , DQS <sub>c</sub> falling edge setup to CK <sub>t</sub> , CK <sub>c</sub> rising edge	<sup>t</sup> DSS	0.18	-	0.18	-	0.18	-	0.18	-
DQS <sub>t</sub> , DQS <sub>c</sub> falling edge hold from CK <sub>t</sub> , CK <sub>c</sub> rising edge	<sup>t</sup> DSH	0.18	-	0.18	-	0.18	-	0.18	-
DQS <sub>t</sub> , DQS <sub>c</sub> differential WRITE preamble	<sup>t</sup> WPRE	0.9	-	0.9	-	0.9	-	0.9	-
DQS <sub>t</sub> , DQS <sub>c</sub> differential WRITE postamble	<sup>t</sup> WPST	0.33	-	0.33	-	0.33	-	0.33	-
<b>DQS Strobe Output Timing (DLL enabled)</b>									
DQS <sub>t</sub> , DQS <sub>c</sub> rising edge output access time from rising CK <sub>t</sub> , CK <sub>c</sub>	<sup>t</sup> DQSCK	-225	225	-195	195	-180	180	-175	175
DQS <sub>t</sub> , DQS <sub>c</sub> rising edge output variance window per DRAM	<sup>t</sup> DQSCKi	-	370	-	330	-	310	-	290
DQS <sub>t</sub> , DQS <sub>c</sub> differential output high time	<sup>t</sup> QSH	0.38	-	0.38	-	0.38	-	0.38	-
DQS <sub>t</sub> , DQS <sub>c</sub> differential output low time	<sup>t</sup> QSL	0.38	-	0.38	-	0.38	-	0.38	-
DQS <sub>t</sub> , DQS <sub>c</sub> Low-Z time (RL - 1)	<sup>t</sup> LZDQS	-450	225	-390	195	-360	180	-300	150
DQS <sub>t</sub> , DQS <sub>c</sub> High-Z time (RL + BL/2)	<sup>t</sup> HZDQS	-	225	-	195	-	180	-	150
DQS <sub>t</sub> , DQS <sub>c</sub> differential READ preamble	<sup>t</sup> RPRE	0.9	-	0.9	-	0.9	-	0.9	-
DQS <sub>t</sub> , DQS <sub>c</sub> differential READ postamble	<sup>t</sup> RPST	0.33	-	0.33	-	0.33	-	0.33	-
<b>Command and Address Timing</b>									

**Table 149: Electrical Characteristics and AC Timing Parameters: DDR4-1600 through DDR4-2400 (Continued)**

Parameter	Symbol	DDR4-1600		DDR4-1866		DDR4-2133		DDR4-2400	
		Min	Max	Min	Max	Min	Max	Min	Max
DLL locking time	<sup>t</sup> DLLK	597	-	597	-	768	-	768	-
CMD, ADDR setup time to CK <sub>t</sub> , CK <sub>c</sub> Base referenced to V <sub>IH(AC)</sub> and V <sub>IL(AC)</sub> levels	Base	115	-	100	-	80	-	62	-
	V <sub>REFCA</sub>	215	-	200	-	180	-	162	-
CMD, ADDR hold time to CK <sub>t</sub> , CK <sub>c</sub> Base referenced to V <sub>IH(DC)</sub> and V <sub>IL(DC)</sub> levels	Base	140	-	125	-	105	-	87	-
	V <sub>REFCA</sub>	215	-	200	-	180	-	162	-
CTRL, ADDR pulse width for each input	<sup>t</sup> IPW	600	-	525	-	460	-	410	-
ACTIVATE to internal READ or WRITE delay	<sup>t</sup> RCD	See Speed Bin Tables for <sup>t</sup> RCD							
PRECHARGE command period	<sup>t</sup> RP	See Speed Bin Tables for <sup>t</sup> RP							
ACTIVATE-to-PRECHARGE command period	<sup>t</sup> RAS	See Speed Bin Tables for <sup>t</sup> RAS							
ACTIVATE-to-ACTIVATE or REF command period	<sup>t</sup> RC	See Speed Bin Tables for <sup>t</sup> RC							
ACTIVATE-to-ACTIVATE command period to different bank groups for 1/2KB page size	<sup>t</sup> RRD_S (1/2KB)	MIN = greater of 4CK or 5ns	MIN = greater of 4CK or 4.2ns	MIN = greater of 4CK or 3.7ns	MIN = greater of 4CK or 3.7ns	MIN = greater of 4CK or 3.7ns	MIN = greater of 4CK or 3.7ns	MIN = greater of 4CK or 3.7ns	MIN = greater of 4CK or 3.7ns
ACTIVATE-to-ACTIVATE command period to different bank groups for 1KB page size	<sup>t</sup> RRD_S (1KB)	MIN = greater of 4CK or 5ns	MIN = greater of 4CK or 4.2ns	MIN = greater of 4CK or 3.7ns	MIN = greater of 4CK or 3.7ns	MIN = greater of 4CK or 3.7ns	MIN = greater of 4CK or 3.7ns	MIN = greater of 4CK or 3.7ns	MIN = greater of 4CK or 3.7ns
ACTIVATE-to-ACTIVATE command period to different bank groups for 2KB page size	<sup>t</sup> RRD_S (2KB)	MIN = greater of 4CK or 6ns	MIN = greater of 4CK or 5.3ns	MIN = greater of 4CK or 5.3ns	MIN = greater of 4CK or 5.3ns	MIN = greater of 4CK or 5.3ns	MIN = greater of 4CK or 5.3ns	MIN = greater of 4CK or 5.3ns	MIN = greater of 4CK or 5.3ns
ACTIVATE-to-ACTIVATE command period to same bank groups for 1/2KB page size	<sup>t</sup> RRD_L (1/2KB)	MIN = greater of 4CK or 6ns	MIN = greater of 4CK or 5.3ns	MIN = greater of 4CK or 5.3ns	MIN = greater of 4CK or 5.3ns	MIN = greater of 4CK or 5.3ns	MIN = greater of 4CK or 5.3ns	MIN = greater of 4CK or 5.3ns	MIN = greater of 4CK or 5.3ns
ACTIVATE-to-ACTIVATE command period to same bank groups for 1KB page size	<sup>t</sup> RRD_L (1KB)	MIN = greater of 4CK or 6ns	MIN = greater of 4CK or 5.3ns	MIN = greater of 4CK or 5.3ns	MIN = greater of 4CK or 5.3ns	MIN = greater of 4CK or 5.3ns	MIN = greater of 4CK or 5.3ns	MIN = greater of 4CK or 5.3ns	MIN = greater of 4CK or 5.3ns
ACTIVATE-to-ACTIVATE command period to same bank groups for 2KB page size	<sup>t</sup> RRD_L (2KB)	MIN = greater of 4CK or 7.5ns	MIN = greater of 4CK or 6.4ns	MIN = greater of 4CK or 6.4ns	MIN = greater of 4CK or 6.4ns	MIN = greater of 4CK or 6.4ns	MIN = greater of 4CK or 6.4ns	MIN = greater of 4CK or 6.4ns	MIN = greater of 4CK or 6.4ns
Four ACTIVATE windows for 1/2KB page size	<sup>t</sup> FAW (1/2KB)	MIN = greater of 16CK or 20ns	MIN = greater of 16CK or 17ns	MIN = greater of 16CK or 15ns	MIN = greater of 16CK or 15ns	MIN = greater of 16CK or 15ns	MIN = greater of 16CK or 15ns	MIN = greater of 16CK or 15ns	MIN = greater of 16CK or 15ns

**Table 149: Electrical Characteristics and AC Timing Parameters: DDR4-1600 through DDR4-2400 (Continued)**

Parameter	Symbol	DDR4-1600		DDR4-1866		DDR4-2133		DDR4-2400	
		Min	Max	Min	Max	Min	Max	Min	Max
Four ACTIVATE windows for 1KB page size	<sup>t</sup> FAW (1KB)	MIN = greater of 20CK or 25ns	MIN = greater of 20CK or 25ns	MIN = greater of 20CK or 23ns	MIN = greater of 20CK or 21ns	MIN = greater of 20CK or 21ns	MIN = greater of 20CK or 21ns	MIN = greater of 20CK or 21ns	MIN = greater of 20CK or 21ns
Four ACTIVATE windows for 2KB page size	<sup>t</sup> FAW (2KB)	MIN = greater of 28CK or 35ns	MIN = greater of 28CK or 35ns	MIN = greater of 28CK or 30ns	MIN = greater of 28CK or 30ns	MIN = greater of 28CK or 30ns	MIN = greater of 28CK or 30ns	MIN = greater of 28CK or 30ns	MIN = greater of 28CK or 30ns
WRITE recovery time	<sup>t</sup> WR	MIN = 15ns							
WRITE recovery time when CRC and DM are both enabled	<sup>t</sup> WR <sub>2</sub>	MIN = 1CK + <sup>t</sup> WR							
Delay from start of internal WRITE transaction to internal READ command – Same bank group	<sup>t</sup> WR_CRC_DM	MIN = <sup>t</sup> WR_L + greater of (4CK or 3.75ns)	MIN = <sup>t</sup> WR_L + greater of (5CK or 3.75ns)	MIN = 1CK + <sup>t</sup> WR_CRC_DM					
Delay from start of internal WRITE transaction to internal READ command – Same bank group	<sup>t</sup> WR_CRC_DM <sub>2</sub>	MIN = 1CK + <sup>t</sup> WR_CRC_DM							
Delay from start of internal WRITE transaction to internal READ command – Different bank group	<sup>t</sup> WTR_L	MIN = greater of 4CK or 7.5ns							
Delay from start of internal WRITE transaction to internal READ command – Different bank group	<sup>t</sup> WTR_L <sub>2</sub>	MIN = 1CK + <sup>t</sup> WTR_L							
Delay from start of internal WRITE transaction to internal READ command – Different bank group	<sup>t</sup> WTR_L_CRC_DM	MIN = <sup>t</sup> WR_S + greater of (4CK or 3.75ns)	MIN = <sup>t</sup> WR_S + greater of (4CK or 3.75ns)	MIN = <sup>t</sup> WR_S + greater of (5CK or 3.75ns)					
Delay from start of internal WRITE transaction to internal READ command – Different bank group	<sup>t</sup> WTR_L_CRC_DM <sub>2</sub>	MIN = 1CK + <sup>t</sup> WTR_L_CRC_DM							
Delay from start of internal WRITE transaction to internal READ command – Different bank group	<sup>t</sup> WTR_S	MIN = greater of (2CK or 2.5ns)							
Delay from start of internal WRITE transaction to internal READ command – Different bank group	<sup>t</sup> WTR_S <sub>2</sub>	MIN = 1CK + <sup>t</sup> WTR_S							
Delay from start of internal WRITE transaction to internal READ command – Different bank group	<sup>t</sup> WTR_S_CRC_DM	MIN = <sup>t</sup> WR + greater of (4CK or 3.75ns)	MIN = <sup>t</sup> WR + greater of (4CK or 3.75ns)	MIN = <sup>t</sup> WR + greater of (5CK or 3.75ns)					
Delay from start of internal WRITE transaction to internal READ command – Different bank group	<sup>t</sup> WTR_S_CRC_DM <sub>2</sub>	MIN = 1CK + <sup>t</sup> WTR_S_CRC_DM							
READ-to-PRECHARGE time	<sup>t</sup> rTP	MIN = greater of 4CK or 7.5ns							
CAS <sub>n</sub> -to-CAS <sub>n</sub> command delay to different bank group	<sup>t</sup> CCD_S	4	-	4	-	4	-	4	-

**Table 149: Electrical Characteristics and AC Timing Parameters: DDR4-1600 through DDR4-2400 (Continued)**

Parameter	Symbol	DDR4-1600		DDR4-1866		DDR4-2133		DDR4-2400	
		Min	Max	Min	Max	Min	Max	Min	Max
CAS_n-to-CAS_n command delay to same bank group	$t_{CCD\_L}$	MIN = greater of 4CK or 6.25ns	-	MIN = greater of 4CK or 5.355ns	-	MIN = greater of 4CK or 5.355ns	-	MIN = greater of 4CK or 5ns	-
Auto precharge write recovery + pre-charge time	$t_{DAL}$ (MIN)	MIN = WR + ROUNDUP $t_{RP}/f_{CK}$ (AVG); MAX = N/A							
<b>MRS Command Timing</b>									
MRS command cycle time	$t_{MRD}$	8	-	8	-	8	-	8	-
MRS command cycle time in PDA mode	$t_{MRD\_PDA}$	MIN = greater of (16nCK, 10ns)							
MRS command cycle time in CAL mode	$t_{MRD\_CAL}$	MIN = $t_{MOD} + {}^tCAL$							
MRS command update delay in PDA mode	$t_{MOD}$	MIN = greater of (24nCK, 15ns)							
MRS command update delay	$t_{MOD\_PDA}$	MIN = $t_{MOD}$							
MRS command update delay in CAL mode	$t_{MOD\_CAL}$	MIN = $t_{MOD} + {}^tCAL$							
MRS command to DQS drive in preamble training	$t_{SDO}$	MIN = $t_{MOD} + 9ns$							
<b>MPR Command Timing</b>									
Multipurpose register recovery time	$t_{MPRR}$	MIN = 1CK							
Multipurpose register write recovery time	$t_{WR\_MPRR}$	MIN = $t_{MOD} + AL + PL$							
<b>CRC Error Reporting Timing</b>									
CRC error to ALERT_n latency	$t_{CRC\_ALERT}$	3	13	3	13	3	13	3	13
CRC ALERT_n pulse width	$t_{CRC\_ALERT\_PW}$	6	10	6	10	6	10	6	10
<b>CA Parity Timing</b>									
Parity latency	PL	4	-	4	-	4	-	5	-
Commands uncertain to be executed during this time	$t_{PAR\_UNKNOWN}$	-	PL	-	PL	-	PL	-	PL
Delay from errant command to ALERT_n assertion	$t_{PAR\_ALERT\_ON}$	-	PL + 6ns	-	PL + 6ns	-	PL + 6ns	-	PL + 6ns
Pulse width of ALERT_n signal when asserted	$t_{PAR\_ALERT\_PW}$	48	96	56	112	64	128	72	144

**Table 149: Electrical Characteristics and AC Timing Parameters: DDR4-1600 through DDR4-2400 (Continued)**

Parameter	Symbol	DDR4-1600		DDR4-1866		DDR4-2133		DDR4-2400	
		Min	Max	Min	Max	Min	Max	Min	Max
Time from alert asserted until DES commands required in persistent CA parity mode	$t_{PAR\_ALERT\_RS\_P}$	-	43	-	50	-	57	-	64
<b>CAL Timing</b>									
CS_n to command address latency	$t_{CAL}$	3	-	4	-	4	-	5	-
CS_n to command address latency in gear-down mode	$t_{CALg}$	N/A	-	N/A	-	N/A	-	N/A	-
<b>MPSM Timing</b>									
Command path disable delay upopn MPSM entry	$t_{MPED}$	MIN = $t_{MOD}$ (MIN) + $t_{CPDED}$ (MIN)							
Valid clock requirement after MPSM entry	$t_{CKMPE}$	MIN = $t_{MOD}$ (MIN) + $t_{CPDED}$ (MIN)							
Valid clock requirement before MPSM exit	$t_{CKMPX}$	MIN = $t_{CK} - t_{SRX}$ (MIN)							
Exit MPSM to commands not requiring a locked DLL	$t_{XMP}$	$t_{XS}$ (MIN)							
Exit MPSM to commands requiring a locked DLL	$t_{XMPDLL}$	MIN = $t_{XMP}$ (MIN) + $t_{XSDLL}$ (MIN)							
CS setup time to CKE	$t_{MPX\_S}$	MIN = $t_{IS}$ (MIN) + $t_{IH}$ (MIN)							
CS_n HIGH hold time to CKE rising edge	$t_{MPX\_HH}$	MIN = $t_{XP}$							
CS_n LOW hold time to CKE rising edge	$t_{MPX\_LH}$	12	$t_{XMP-1}$ Ons	12	$t_{XMP-1}$ Ons	12	$t_{XMP-1}$ Ons	12	$t_{XMP}$ Ons
<b>Connectivity Test Timing</b>									
TEN pin HIGH to CS_n LOW – Enter CT mode	$t_{CT\_Enable}$	200	-	200	-	200	-	200	-
CS_n LOW and valid input to valid output	$t_{CT\_Valid}$	-	200	-	200	-	200	-	200
CK_t, CK_c valid and CKE HIGH after TEN goes HIGH	$t_{CTECT\_Valid}$	10	-	10	-	10	-	10	-
<b>Calibration and V<sub>REFDQ</sub> Train Timing</b>									
ZQCL command: Long calibration time	POWER-UP and RESET operation Normal operation	$t_{ZQinit}$	-	1024	-	1024	-	1024	-
		$t_{ZQoper}$	512	-	512	-	512	-	512

**Table 149: Electrical Characteristics and AC Timing Parameters: DDR4-1600 through DDR4-2400 (Continued)**

Parameter	Symbol	DDR4-1600		DDR4-1866		DDR4-2133		DDR4-2400	
		Min	Max	Min	Max	Min	Max	Min	Max
ZQCS command: Short calibration time	<sup>t</sup> ZQCS	128	-	128	-	128	-	128	-
The V <sub>REF</sub> increment/decrement step time	V <sub>REF_time</sub>	MIN = 150ns							
Enter V <sub>REFDQ</sub> training mode to the first write or V <sub>REFDQ</sub> MRS command delay	<sup>t</sup> VREFDQE	MIN = 150ns							
Exit V <sub>REFDQ</sub> training mode to the first WRITE command delay	<sup>t</sup> VREFDQX	MIN = 150ns							
<b>Initialization and Reset Timing</b>									
Exit reset from CKE HIGH to a valid command	<sup>t</sup> XPR	MIN = greater of 5CK or <sup>t</sup> RFC (MIN) + 10ns							
RESET_L pulse low after power stable	<sup>t</sup> PW_REST_S	0.1	-	0.1	-	0.1	-	0.1	-
RESET_L pulse low at power-up	<sup>t</sup> PW_REST_L	200	-	200	-	200	-	200	-
Begin power supply ramp to power supplies stable	<sup>t</sup> VDDPR	MIN = N/A; MAX = 200							
RESET_n LOW to power supplies stable	<sup>t</sup> RPS	MIN = 0; MAX = 0							
RESET_n LOW to I/O and R <sub>TT</sub> High-Z	<sup>t</sup> IOZ	MIN = N/A; MAX = undefined							
<b>Refresh Timing</b>									
REFRESH-to-ACTIVATE or REFRESH command period (all bank groups)	<sup>t</sup> RFC1	MIN = 260							
	<sup>t</sup> RFC2	MIN = 160							
	<sup>t</sup> RFC4	MIN = 110							
8Glb	<sup>t</sup> RFC1	MIN = 350							
	<sup>t</sup> RFC2	MIN = 260							
	<sup>t</sup> RFC4	MIN = 160							
16Glb	<sup>t</sup> RFC1	MIN = 550							
	<sup>t</sup> RFC2	MIN = 405							
	<sup>t</sup> RFC4	MIN = 250							
Average periodic refresh interval	<sup>t</sup> REFI	MIN = N/A; MAX = 7.8							
	<sup>t</sup> REFI	MIN = N/A; MAX = 3.9							
<b>Self Refresh Timing</b>									
Exit self refresh to commands not requiring a locked DLL SRX to commands not requiring a locked DLL in self refresh abort	<sup>t</sup> XS	MIN = <sup>t</sup> RFC + 10ns							
	<sup>t</sup> XS_ABORT	MIN = <sup>t</sup> RFC4 + 10ns							

**Table 149: Electrical Characteristics and AC Timing Parameters: DDR4-1600 through DDR4-2400 (Continued)**

Parameter	Symbol	DDR4-1600		DDR4-1866		DDR4-2133		DDR4-2400	
		Min	Max	Min	Max	Min	Max	Min	Max
Exit self refresh to ZQCL, ZQCS and MRS (CL, CWL, WR, RTP and gear-down)	$t_{XS\_FAST}$	MIN = $t_{RFC4} + 10ns$							
Exit self refresh to commands requiring a locked DLL	$t_{XSDLL}$	MIN = $t_{DLLK}$ (MIN)							
Minimum CKE low pulse width for self refresh entry to self refresh exit timing	$t_{CKESR}$	MIN = $t_{CKE}$ (MIN) + 1nCK							
Minimum CKE low pulse width for self refresh entry to self refresh exit timing when CA parity is enabled	$t_{CKESR\_PAR}$	MIN = $t_{CKE}$ (MIN) + 1nCK + PL							
Valid clocks after self refresh entry (SRE) or power-down entry (PDE)	$t_{CKSRE}$	MIN = greater of (5CK, 10ns)							
Valid clock requirement after self refresh entry or power-down when CA parity is enabled	$t_{CKSRE\_PAR}$	MIN = greater of (5CK, 10ns) + PL							
Valid clocks before self refresh exit (SRX) or power-down exit (PDX), or reset exit	$t_{CKSRX}$	MIN = greater of (5CK, 10ns)							
<b>Power-Down Timing</b>									
Exit power-down with DLL on to any valid command	$t_{XP}$	MIN = greater of 4CK or 6ns							
Exit precharge power-down with DLL frozen to commands not requiring a locked DLL when CA Parity is enabled.	$t_{XP\_PAR}$	MIN = (greater of 4CK or 6ns) + PL							
CKE MIN pulse width	$t_{CKE}$ (MIN)	MIN = greater of 3CK or 5ns							
Command pass disable delay	$t_{CPDED}$	4	-	4	-	4	-	4	-
Power-down entry to power-down exit timing	$t_{PD}$	MIN = $t_{CKE}$ (MIN); MAX = 9 x $t_{REFI}$							
Begin power-down period prior to CKE registered HIGH	$t_{ANPD}$	WL - 1CK							
Power-down entry period: ODT either synchronous or asynchronous	PDE	Greater of $t_{ANPD}$ or $t_{RFC}$ - REFRESH command to CKE LOW time							
Power-down exit period: ODT either synchronous or asynchronous	PDX	$t_{ANPD} + t_{XSDLL}$							
<b>Power-Down Entry Minimum Timing</b>									

**Table 149: Electrical Characteristics and AC Timing Parameters: DDR4-1600 through DDR4-2400 (Continued)**

Parameter	Symbol	DDR4-1600		DDR4-1866		DDR4-2133		DDR4-2400	
		Min	Max	Min	Max	Min	Max	Min	Max
ACTIVATE command to power-down entry	<sup>t</sup> ACTPDEN	1	-	1	-	2	-	2	-
PRECHARGE/PRECHARGE ALL command to power-down entry	<sup>t</sup> PRPDEN	1	-	1	-	2	-	2	-
REFRESH command to power-down entry	<sup>t</sup> REFPDEN	1	-	1	-	2	-	2	-
MRS command to power-down entry	<sup>t</sup> MRSPDEN	MIN = <sup>t</sup> MOD (MIN)							
READ/READ with auto precharge command to power-down entry	<sup>t</sup> RDPDEN	MIN = RL + 4 + 1							
WRITE command to power-down entry (BL8OTF, BL8MRS, BC4OTF)	<sup>t</sup> WRPDEN	MIN = WL + 4 + <sup>t</sup> WR/ <sup>t</sup> CK(AVG)							
WRITE command to power-down entry (BC4MRS)	<sup>t</sup> WRPBC4DEN	MIN = WL + 2 + <sup>t</sup> WR/ <sup>t</sup> CK(AVG) CK							
WRITE with auto precharge command to power-down entry (BL8OTF, BL8MRS, BC4OTF)	<sup>t</sup> WRAPDEN	MIN = WL + 4 + WR + 1							
WRITE with auto precharge command to power-down entry (BC4MRS)	<sup>t</sup> WRAPBC4DEN	MIN = WL + 2 + WR + 1							
<b>ODT Timing</b>									
Direct ODT turn-on latency	DODTLon	WL - 2 = CWL + AL + PL - 2							
Direct ODT turn-off latency	DODTLoff	WL - 2 = CWL + AL + PL - 2							
R <sub>TT</sub> dynamic change skew	<sup>t</sup> ADC	0.3	0.7	0.3	0.7	0.3	0.7	0.3	0.7
Asynchronous R <sub>TT(NOM)</sub> turn-on delay (DLL off)	<sup>t</sup> AONAS	1	9	1	9	1	9	1	9
Asynchronous R <sub>TT(NOM)</sub> turn-off delay (DLL off)	<sup>t</sup> AOFAS	1	9	1	9	1	9	1	9
ODT HIGH time with WRITE command and BL8	ODTH8 1 <sup>t</sup> CK	6	-	6	-	6	-	6	-
	ODTH8 2 <sup>t</sup> CK	7	-	7	-	7	-	7	-
ODT HIGH time without WRITE command or with WRITE command and BC4	ODTH4 1 <sup>t</sup> CK	4	-	4	-	4	-	4	-
	ODTH4 2 <sup>t</sup> CK	5	-	5	-	5	-	5	-
<b>Write Leveling Timing</b>									
First DQS <sub>t</sub> , DQS <sub>c</sub> rising edge after write leveling mode is programmed	<sup>t</sup> WLMRD	40	-	40	-	40	-	40	-

**Table 149: Electrical Characteristics and AC Timing Parameters: DDR4-1600 through DDR4-2400 (Continued)**

Parameter	Symbol	DDR4-1600		DDR4-1866		DDR4-2133		DDR4-2400	
		Min	Max	Min	Max	Min	Max	Min	Max
DQS <sub>t</sub> , DQS <sub>c</sub> delay after write leveling mode is programmed	<sup>t</sup> WLDQSEN	25	–	25	–	25	–	25	–
Write leveling setup from rising CK <sub>t</sub> , CK <sub>c</sub> crossing to rising DQS <sub>t</sub> , DQS <sub>c</sub> crossing	<sup>t</sup> WLS	0.13	–	0.13	–	0.13	–	0.13	–
Write leveling hold from rising DQS <sub>t</sub> , DQS <sub>c</sub> crossing to rising CK <sub>t</sub> , CK <sub>c</sub> crossing	<sup>t</sup> WLH	0.13	–	0.13	–	0.13	–	0.13	–
Write leveling output delay	<sup>t</sup> WLO	0	9.5	0	9.5	0	9.5	0	9.5
Write leveling output error	<sup>t</sup> WLOE	0	2	0	2	0	2	0	2
<b>Gear-Down Timing (Not Supported Below DDR4-2666)</b>									
Exit reset from CKE HIGH to a valid MRS gear-down	<sup>t</sup> XPR_GEAR	N/A	N/A	N/A	N/A	N/A	N/A	N/A	N/A
CKE HIGH assert to gear-down enable (time)	<sup>t</sup> XS_GEAR	N/A	N/A	N/A	N/A	N/A	N/A	N/A	N/A
MRS command to sync pulse time	<sup>t</sup> SYNC_GEAR	N/A	N/A	N/A	N/A	N/A	N/A	N/A	N/A
Sync pulse to first valid command	<sup>t</sup> CMD_GEAR	N/A	N/A	N/A	N/A	N/A	N/A	N/A	N/A
Gear-down setup time	<sup>t</sup> GEAR_setup	N/A	–	N/A	–	N/A	–	N/A	–
Gear-down hold time	<sup>t</sup> GEAR_hold	N/A	–	N/A	–	N/A	–	N/A	–

- Notes:
1. Maximum limit not applicable.
  2.  $t_{CCD\_L}$  and  $t_{DLLK}$  should be programmed according to the value defined per operating frequency.
  3. Although unlimited row accesses to the same row is allowed within the refresh period, excessive row accesses to the same row over a long term can result in degraded operation.
  4. Data rate is less than or equal to 1333 Mb/s.
  5. Data rate is less than or equal to TBD.
  6. WRITE-to-READ when CRC and DM are both not enabled.
  7. WRITE-to-READ delay when CRC and DM are both enabled.
  8. The start of internal write transactions is defined as follows:
    - For BL8 (fixed by MRS and on-the-fly): rising clock edge four clock cycles after WL
    - For BC4 (on-the-fly): rising clock edge four clock cycles after WL
    - For BC4 (fixed by MRS): rising clock edge two clock cycles after WL
  9. For these parameters, the device supports  $t_{nPARAM} [nCK] = RU\{t_{PARAM} [ns]/t_{CK}(AVG) [ns]\}$ , in clock cycles, assuming all input clock jitter specifications are satisfied.
  10. When operating in  $1^{tCK}$  WRITE preamble mode.
  11. When operating in  $2^{tCK}$  WRITE preamble mode.
  12. When CA parity mode is selected and the DLLoff mode is used, each REF command requires an additional "PL" added to  $t_{RFC}$  refresh time.
  13. DRAM devices should be evenly addressed when being accessed. Disproportionate accesses to a particular row address may result in reduction of the product lifetime and/or reduction in data retention ability.
  14. Applicable from  $t_{CK} (AVG) MIN$  to  $t_{CK} (AVG) MAX$  as stated in the Speed Bin tables.
  15. JEDEC specifies a minimum of five clocks.

# Electrical Characteristics and AC Timing Parameters: 2666 Through 3200

**Table 150: Electrical Characteristics and AC Timing Parameters**

Parameter	Symbol	Clock Timing						Reserved		
		DDR4-2666		DDR4-2933		DDR4-3200		Min	Max	
Clock period average (DLL off mode)	t <sub>CK (DLL_OFF)</sub>	8	20	8	8	20	8	20		
Clock period average	t <sub>CK (AVG, DLL_ON)</sub>	0.75	1.6	0.682	1.6	0.625	1.6	1.6		
High pulse width average	t <sub>CH (AVG)</sub>	0.48	0.52	0.48	0.52	0.48	0.52	0.52		
Low pulse width average	t <sub>CL (AVG)</sub>	0.48	0.52	0.48	0.52	0.48	0.52	0.52		
Clock period jitter	Total	-38	38	-34	34	-31	31	31		
	Deterministic	-19	19	-17	17	-16	16	16		
	DLL locking	-30	30	-27	27	-25	25	25		
Clock absolute period	t <sub>CK (ABS)</sub>	MIN = t <sub>CK (AVG)</sub> MIN + t <sub>JITper_tot</sub> MIN; MAX = t <sub>CK (AVG)</sub> MAX + t <sub>JITper_tot</sub> MAX								
Clock absolute high pulse width (includes duty cycle jitter)	t <sub>CH (ABS)</sub>	0.45	-	0.45	-	0.45	-	0.45	-	
Clock absolute low pulse width (includes duty cycle jitter)	t <sub>CL (ABS)</sub>	0.45	-	0.45	-	0.45	-	0.45	-	
Cycle-to-cycle jitter	Total	75		-68		63				
	Deterministic	38		-34		31				
	DLL locking	60		-68		50				

**Table 150: Electrical Characteristics and AC Timing Parameters (Continued)**

Parameter	Symbol	DDR4-2666		DDR4-2933		DDR4-3200		Reserved	
		Min	Max	Min	Max	Min	Max	Min	Max
Cumulative error across	2 cycles	-55	55	-50	50	-46	46		
	3 cycles	-66	66	-59	59	-55	55		
	4 cycles	-73	73	-66	66	-61	61		
	5 cycles	-79	79	-71	71	-65	65		
	6 cycles	-83	83	-75	75	-69	69		
	7 cycles	-87	87	-79	79	-73	73		
	8 cycles	-91	91	-82	82	-75	75		
	9 cycles	-94	94	-85	85	-78	78		
	10 cycles	-96	96	-87	87	-80	80		
	11 cycles	-99	99	-89	89	-82	82		
	12 cycles	-101	101	-91	91	-84	84		
	$n = 13, 14 \dots 49,$ 50 cycles	$t_{ERRnper}$	$t_{ERRnper} MIN = (1 + 0.68 \ln[n]) \times t_{JITper} MIN$ $t_{ERRnper} MAX = (1 + 0.68 \ln[n]) \times t_{JITper} MAX$						
<b>DQ Input Timing</b>									
Data setup time to DQS_t, DQS_c	Base (calibrated $V_{REF}$ )	$t_{DS}$	Refer to DQ Input Receiver Specification section (approximately 0.15°C to 0.28°C)						
	Non-calibrated $V_{REF}$	$t_{PDA\_S}$	minimum of 0.5ui						
Data hold time from DQS_t, DQS_c	Base (calibrated $V_{REF}$ )	$t_{DH}$	Refer to DQ Input Receiver Specification section (approximately 0.15°C to 0.28°C)						
	Non-calibrated $V_{REF}$	$t_{PDA\_H}$	minimum of 0.5UI						
DQ and DM minimum data pulse width for each input		$t_{DIPW}$	0.58	-	0.58	-	0.58	-	-
<b>DQ Output Timing (DLL enabled)</b>									
DQS_t, DQS_c to DQ skew, per group, per access		$t_{DQSQ}$	-	0.18	-	0.18	-	0.18	-
DQ output hold time from DQS_t, DQS_c		$t_{QH}$	0.74	-	0.74	-	0.74	-	-
Data Valid Window per device: $t_{QH} -$ $t_{DQSQ}$ each device's output per IU		$t_{DVW_d}$	0.64	-	0.64	-	0.64	-	-
Data Valid Window per device, per pin: $t_{QH} - t_{DQSQ}$ each device's output per IU		$t_{DVW_p}$	0.72	-	0.72	-	0.72	-	-
DQ Low-Z time from CK_t, CK_c		$t_{LZDQ}$	-340	140	-330	135	-320	130	

**Table 150: Electrical Characteristics and AC Timing Parameters (Continued)**

Parameter	Symbol	DDR4-2666		DDR4-2933		DDR4-3200		Reserved	
		Min	Max	Min	Max	Min	Max	Min	Max
DQ High-Z time from CK_t, CK_c	<sup>t</sup> HZDQ	-	140	-	135	-	130	-	-
<b>DQ Strobe Input Timing</b>									
DQS_t, DQS_c rising edge to CK_t, CK_c rising edge for 1 <sup>t</sup> CKpreamble	<sup>t</sup> DQSS <sub>1ck</sub>	-0.27	0.27	-0.27	0.27	-0.27	0.27	-0.27	0.27
DQS_t, DQS_c rising edge to CK_t, CK_c rising edge for 2 <sup>t</sup> CKpreamble	<sup>t</sup> DQSS <sub>2ck</sub>	-0.5	0.5	-0.5	0.5	-0.5	0.5	-0.5	0.5
DQS_t, DQS_c differential input low pulse width	<sup>t</sup> DQSL	0.46	0.54	0.46	0.54	0.46	0.54	0.46	0.54
DQS_t, DQS_c differential input high pulse width	<sup>t</sup> DQSH	0.46	0.54	0.46	0.54	0.46	0.54	0.46	0.54
DQS_t, DQS_c falling edge setup to CK_t, CK_c rising edge	<sup>t</sup> DSS	0.18	-	0.18	-	0.18	-	0.18	-
DQS_t, DQS_c falling edge hold from CK_t, CK_c rising edge	<sup>t</sup> DSH	0.18	-	0.18	-	0.18	-	0.18	-
DQS_t, DQS_c differential WRITE preamble	<sup>t</sup> WPRE	0.9	-	0.9	-	0.9	-	0.9	-
DQS_t, DQS_c differential WRITE postamble	<sup>t</sup> WPST	0.33	-	0.33	-	0.33	-	0.33	-
<b>DQS Strobe Output Timing (DLL enabled)</b>									
DQS_t, DQS_c rising edge output access time from rising CK_t, CK_c	<sup>t</sup> DQSCK	-170	170	-165	165	-160	160	-160	160
DQS_t, DQS_c rising edge output variance window per DRAM	<sup>t</sup> DQSCKi	-	270	-	265	-	260	-	260
DQS_t, DQS_c differential output high time	<sup>t</sup> QSH	0.40	-	0.40	-	0.40	-	0.40	-
DQS_t, DQS_c differential output low time	<sup>t</sup> QSL	0.40	-	0.40	-	0.40	-	0.40	-
DQS_t, DQS_c Low-Z time (RL - 1)	<sup>t</sup> LZDQS	-340	140	-330	130	-320	130	-320	130
DQS_t, DQS_c High-Z time (RL + BL/2)	<sup>t</sup> HZDQS	-	140	-	135	-	130	-	130
DQS_t, DQS_c differential READ preamble	<sup>t</sup> RPRE	0.9	-	0.9	-	0.9	-	0.9	-
DQS_t, DQS_c differential READ postamble	<sup>t</sup> RPST	0.33	-	0.33	-	0.33	-	0.33	-

**Table 150: Electrical Characteristics and AC Timing Parameters (Continued)**

Parameter	Symbol	Command and Address Timing				Reserved	
		Min	Max	Min	Max	Min	Max
DLL locking time	t <sup>DLLK</sup>	854	–	940	–	1024	–
CMD, ADDR setup time	t <sup>IS</sup>	55	–	48	–	40	–
to CK <sub>t</sub> , CK <sub>c</sub> referenced to V <sub>IH(AC)</sub> and V <sub>IL(AC)</sub> levels	t <sup>ISVREF</sup>	145	–	138	–	130	–
CMD, ADDR hold time	t <sup>IH</sup>	80	–	73	–	65	–
to CK <sub>t</sub> , CK <sub>c</sub> referenced to V <sub>IH(DC)</sub> and V <sub>IL(DC)</sub> levels	t <sup>IHVREF</sup>	145	–	138	–	130	–
CTRL, ADDR pulse width for each input	t <sup>IPW</sup>	385	–	365	–	350	–
ACTIVATE to internal READ or WRITE delay	t <sup>RCD</sup>	See Speed Bin Tables for t <sup>RCD</sup>					
PRECHARGE command period	t <sup>RP</sup>	See Speed Bin Tables for t <sup>RP</sup>					
ACTIVATE-to-PRECHARGE command period	t <sup>RAS</sup>	See Speed Bin Tables for t <sup>RAS</sup>					
ACTIVATE-to-ACTIVATE or REF command period	t <sup>RC</sup>	See Speed Bin Tables for t <sup>RC</sup>					
ACTIVATE-to-ACTIVATE command period to different bank groups for 1/2KB page size	t <sup>RRD_S</sup> (1/2KB)	MIN = greater of 4CK or 3.0ns	MIN = greater of 4CK or 3.0ns	MIN = greater of 4CK or 3.0ns	MIN = greater of 4CK or 3.0ns	MIN = greater of 4CK or 3.0ns	MIN = greater of 4CK or 3.0ns
ACTIVATE-to-ACTIVATE command period to different bank groups for 1KB page size	t <sup>RRD_S</sup> (1KB)	MIN = greater of 4CK or 3.0ns	MIN = greater of 4CK or 3.0ns	MIN = greater of 4CK or 3.0ns	MIN = greater of 4CK or 3.0ns	MIN = greater of 4CK or 3.0ns	MIN = greater of 4CK or 3.0ns
ACTIVATE-to-ACTIVATE command period to different bank groups for 2KB page size	t <sup>RRD_S</sup> (2KB)	MIN = greater of 4CK or 5.3ns	MIN = greater of 4CK or 5.3ns	MIN = greater of 4CK or 5.3ns	MIN = greater of 4CK or 5.3ns	MIN = greater of 4CK or 5.3ns	MIN = greater of 4CK or 5.3ns
ACTIVATE-to-ACTIVATE command period to same bank groups for 1/2KB page size	t <sup>RRD_L</sup> (1/2KB)	MIN = greater of 4CK or 4.9ns	MIN = greater of 4CK or 4.9ns	MIN = greater of 4CK or 4.9ns	MIN = greater of 4CK or 4.9ns	MIN = greater of 4CK or 4.9ns	MIN = greater of 4CK or 4.9ns
ACTIVATE-to-ACTIVATE command period to same bank groups for 1KB page size	t <sup>RRD_L</sup> (1KB)	MIN = greater of 4CK or 4.9ns	MIN = greater of 4CK or 4.9ns	MIN = greater of 4CK or 4.9ns	MIN = greater of 4CK or 4.9ns	MIN = greater of 4CK or 4.9ns	MIN = greater of 4CK or 4.9ns
ACTIVATE-to-ACTIVATE command period to same bank groups for 2KB page size	t <sup>RRD_L</sup> (2KB)	MIN = greater of 4CK or 6.4ns	MIN = greater of 4CK or 6.4ns	MIN = greater of 4CK or 6.4ns	MIN = greater of 4CK or 6.4ns	MIN = greater of 4CK or 6.4ns	MIN = greater of 4CK or 6.4ns

**Table 150: Electrical Characteristics and AC Timing Parameters (Continued)**

Parameter	Symbol	DDR4-2666		DDR4-2933		DDR4-3200		Reserved	
		Min	Max	Min	Max	Min	Max	Min	Max
Four ACTIVATE windows for 1/2KB page size	<sup>t</sup> FAW (1/2KB)	MIN = greater of 16CK or 12ns		MIN = greater of 16CK or 12ns		MIN = greater of 16CK or 11.9ns			
Four ACTIVATE windows for 1KB page size	<sup>t</sup> FAW (1KB)	MIN = greater of 20CK or 21ns		MIN = greater of 20CK or 21ns		MIN = greater of 20CK or 21ns			
Four ACTIVATE windows for 2KB page size	<sup>t</sup> FAW (2KB)	MIN = greater of 28CK or 30ns		MIN = greater of 28CK or 30ns		MIN = greater of 28CK or 30ns			
WRITE recovery time	<sup>t</sup> WR	MIN = 15ns							
WRITE recovery time when CRC and DM are both enabled	<sup>t</sup> WR <sub>2</sub>	MIN = 1CK + <sup>t</sup> WR							
WRITE recovery time when CRC and DM are both enabled	<sup>t</sup> WR_CRC_DM	MIN = <sup>t</sup> WR + greater of (5CK or 3.75ns)							
Delay from start of internal WRITE transaction to internal READ command – Same bank group	<sup>t</sup> WR_CRC_DM <sub>2</sub>	MIN = 1CK + <sup>t</sup> WR_CRC_DM							
Delay from start of internal WRITE transaction to internal READ command – Different bank group	<sup>t</sup> WTR_L	MIN = greater of 4CK or 7.5ns							
Delay from start of internal WRITE transaction to internal READ command – Different bank group	<sup>t</sup> WTR_L <sub>2</sub>	MIN = 1CK + <sup>t</sup> WTR_L							
Delay from start of internal WRITE transaction to internal READ command – Different bank group	<sup>t</sup> WTR_L_CRC_D M	MIN = <sup>t</sup> WTR_L + greater of (5CK or 3.75ns)							
Delay from start of internal WRITE transaction to internal READ command – Different bank group	<sup>t</sup> WTR_L_CRC_D M <sub>2</sub>	MIN = 1CK + <sup>t</sup> WTR_L_CRC_DM							
Delay from start of internal WRITE transaction to internal READ command – Different bank group	<sup>t</sup> WTR_S	MIN = greater of (2CK or 2.5ns)							
Delay from start of internal WRITE transaction to internal READ command – Different bank group	<sup>t</sup> WTR_S <sub>2</sub>	MIN = 1CK + <sup>t</sup> WTR_S							
Delay from start of internal WRITE transaction to internal READ command – Different bank group	<sup>t</sup> WTR_S_CRC_D M	MIN = <sup>t</sup> WTR_S + greater of (5CK or 3.75ns)							
Delay from start of internal WRITE transaction to internal READ command – Different bank group	<sup>t</sup> WTR_S_CRC_D M <sub>2</sub>	MIN = 1CK + <sup>t</sup> WTR_S_CRC_DM							
READ-to-PRECHARGE time	<sup>t</sup> RTP	MIN = greater of 4CK or 7.5ns							
CAS <sub>n</sub> -to-CAS <sub>n</sub> command delay to different bank group	<sup>t</sup> CCD_S	4	-	4	-	4	-	-	-

**Table 150: Electrical Characteristics and AC Timing Parameters (Continued)**

Parameter	Symbol	DDR4-2666		DDR4-2933		DDR4-3200		Reserved	
		Min	Max	Min	Max	Min	Max	Min	Max
CAS_n-to-CAS_n command delay to same bank group	$t_{CCD\_L}$	MIN = greater of 4CK or 5ns	-	MIN = greater of 4CK or 5ns	-	MIN = greater of 4CK or 5ns	-		
Auto precharge write recovery + pre-charge time	$t_{DAL}$ (MIN)	MIN = WR + ROUNDUP $t_{RP}/f_{CK}$ (AVG); MAX = N/A							
<b>MRS Command Timing</b>									
MRS command cycle time	$t_{MRD}$	9	-	10	-	10	-		
MRS command cycle time in PDA mode	$t_{MRD\_PDA}$	MIN = greater of (16nCK, 10ns)							
MRS command cycle time in CAL mode	$t_{MRD\_CAL}$	MIN = $t_{MOD} + t_{CAL}$							
MRS command update delay in PDA mode	$t_{MOD}$	MIN = greater of (24nCK, 15ns)							
MRS command update delay	$t_{MOD\_PDA}$	MIN = $t_{MOD}$							
MRS command update delay in CAL mode	$t_{MOD\_CAL}$	MIN = $t_{MOD} + t_{CAL}$							
MRS command to DQS drive in preamble training	$t_{SDO}$	MIN = $t_{MOD} + 9ns$							
<b>MPR Command Timing</b>									
Multipurpose register recovery time	$t_{MPRR}$	MIN = 1nCK							
Multipurpose register write recovery time	$t_{WR\_MPRR}$	MIN = $t_{MOD} + AL + PL$							
<b>CRC Error Reporting Timing</b>									
CRC error to ALERT_n latency	$t_{CRC\_ALERT}$	3	13	3	13	3	13		
CRC ALERT_n pulse width	$t_{CRC\_ALERT\_PW}$	6	10	6	10	6	10		
<b>CA Parity Timing</b>									
Parity latency	PL	6	-	8	-	8	-		
Commands uncertain to be executed during this time	$t_{PAR\_UNKNOWN}$	-	PL	-	PL	-	PL		
Delay from errant command to ALERT_n assertion	$t_{PAR\_ALERT\_ON}$	-	PL + 6ns	-	PL + 6ns	-	PL + 6ns		
Pulse width of ALERT_n signal when asserted	$t_{PAR\_ALERT\_PW}$	80	160	88	176	96	192		

**Table 150: Electrical Characteristics and AC Timing Parameters (Continued)**

Parameter	Symbol	DDR4-2666		DDR4-2933		DDR4-3200		Reserved	
		Min	Max	Min	Max	Min	Max	Min	Max
Time from alert asserted until DES commands required in persistent CA parity mode	t <sub>PAR_ALERT_RS</sub> P	-	71	-	78	-	85		
<b>CAL Timing</b>									
CS_n to command address latency	t <sub>CAL</sub>	5	-	6	-	6	-		
CS_n to command address latency in gear-down mode	t <sub>CALg</sub>	6	-	8	-	8	-		
<b>MPSM Timing</b>									
Command path disable delay upopn MPSM entry	t <sub>MPED</sub>	MIN = t <sub>MOD</sub> (MIN) + t <sub>CPDED</sub> (MIN)							
Valid clock requirement after MPSM entry	t <sub>CKMPE</sub>	MIN = t <sub>MOD</sub> (MIN) + t <sub>CPDED</sub> (MIN)							
Valid clock requirement before MPSM exit	t <sub>CKMPX</sub>	MIN = t <sub>CK</sub> - t <sub>SRX</sub> (MIN)							
Exit MPSM to commands not requiring a locked DLL	t <sub>XMP</sub>	t <sub>XS</sub> (MIN)							
Exit MPSM to commands requiring a locked DLL	t <sub>XMPDLL</sub>	MIN = t <sub>XMP</sub> (MIN) + t <sub>XSDLL</sub> (MIN)							
CS setup time to CKE	t <sub>MPX_S</sub>	MIN = t <sub>IS</sub> (MIN) + t <sub>IH</sub> (MIN)							
CS_n HIGH hold time to CKE rising edge	t <sub>MPX_HH</sub>	MIN = t <sub>XP</sub>							
CS_n LOW hold time to CKE rising edge	t <sub>MPX_LH</sub>	12	t <sub>XMP-1</sub> Ons	12	t <sub>XMP-1</sub> Ons	12	t <sub>XMP-1</sub> Ons		
<b>Connectivity Test Timing</b>									
TEN pin HIGH to CS_n LOW – Enter CT mode	t <sub>CT_Enable</sub>	200	-	200	-	200	-		
CS_n LOW and valid input to valid output	t <sub>CT_Valid</sub>	-	200	-	200	-	200		
CK_t, CK_c valid and CKE HIGH after TEN goes HIGH	t <sub>CTECT_Valid</sub>	10	-	10	-	10	-		
<b>Calibration and V<sub>REFDQ</sub> Train Timing</b>									
ZQCL command: Long calibration time	POWER-UP and RESET operation Normal operation	t <sub>ZQinit</sub>	-	1024	-	1024	-		
		t <sub>ZQoper</sub>	512	-	512	-	512	-	

**Table 150: Electrical Characteristics and AC Timing Parameters (Continued)**

Parameter	Symbol	DDR4-2666		DDR4-2933		DDR4-3200		Reserved	
		Min	Max	Min	Max	Min	Max	Min	Max
ZQCS command: Short calibration time	<sup>t</sup> ZQCS	128	-	128	-	128	-		
The V <sub>REF</sub> increment/decrement step time	V <sub>REF_time</sub>	MIN = 150ns							
Enter V <sub>REFDQ</sub> training mode to the first write or V <sub>REFDQ</sub> MRS command delay	<sup>t</sup> VREFDQE	MIN = 150ns							
Exit V <sub>REFDQ</sub> training mode to the first WRITE command delay	<sup>t</sup> VREFDQX	MIN = 150ns							
<b>Initialization and Reset Timing</b>									
Exit reset from CKE HIGH to a valid command	<sup>t</sup> XPR	MIN = greater of 5CK or <sup>t</sup> RFC (MIN) + 10ns							
RESET_L pulse low after power stable	<sup>t</sup> PW_REST_S	0.1	-	0.1	-	0.1	-		
RESET_L pulse low at power-up	<sup>t</sup> PW_REST_L	200	-	200	-	200	-		
Begin power supply ramp to power supplies stable	<sup>t</sup> VDDPR	MIN = N/A; MAX = 200							
RESET_n LOW to power supplies stable	<sup>t</sup> RPS	MIN = 0; MAX = 0							
RESET_n LOW to I/O and R <sub>TT</sub> High-Z	<sup>t</sup> IOZ	MIN = N/A; MAX = undefined							
<b>Refresh Timing</b>									
REFRESH-to-ACTIVATE or REFRESH command period (all bank groups)	<sup>t</sup> RFC1	MIN = 260							
	<sup>t</sup> RFC2	MIN = 160							
	<sup>t</sup> RFC4	MIN = 110							
	<sup>t</sup> RFC1	MIN = 350							
8Glb	<sup>t</sup> RFC2	MIN = 260							
	<sup>t</sup> RFC4	MIN = 160							
	<sup>t</sup> RFC1	MIN = 550							
16Glb	<sup>t</sup> RFC2	MIN = 405							
	<sup>t</sup> RFC4	MIN = 250							
	<sup>t</sup> REFI	MIN = N/A; MAX = 7.8							
Average periodic refresh interval	<sup>t</sup> REFI	MIN = N/A; MAX = 3.9							
	<sup>t</sup> REFI								
<b>Self Refresh Timing</b>									
Exit self refresh to commands not requiring a locked DLL SRX to commands not requiring a locked DLL in self refresh abort	<sup>t</sup> XS	MIN = <sup>t</sup> RFC + 10ns							
	<sup>t</sup> XS_ABORT	MIN = <sup>t</sup> RFC4 + 10ns							

**Table 150: Electrical Characteristics and AC Timing Parameters (Continued)**

Parameter	Symbol	DDR4-2666		DDR4-2933		DDR4-3200		Reserved	
		Min	Max	Min	Max	Min	Max	Min	Max
Exit self refresh to ZQCL, ZQCS and MRS (CL, CWL, WR, RTP and gear-down)	$t_{XS\_FAST}$	MIN = $t_{RFC4} + 10ns$							
Exit self refresh to commands requiring a locked DLL	$t_{XSDLL}$	MIN = $t_{DLLK}$ (MIN)							
Minimum CKE low pulse width for self refresh entry to self refresh exit timing	$t_{CKESR}$	MIN = $t_{CKE}$ (MIN) + 1nCK							
Minimum CKE low pulse width for self refresh entry to self refresh exit timing when CA parity is enabled	$t_{CKESR\_par}$	MIN = $t_{CKE}$ (MIN) + 1nCK + PL							
Valid clocks after self refresh entry (SRE) or power-down entry (PDE)	$t_{CKSRE}$	MIN = greater of (5CK, 10ns)							
Valid clock requirement after self refresh entry or power-down when CA parity is enabled	$t_{CKSRE\_par}$	MIN = greater of (5CK, 10ns) + PL							
Valid clocks before self refresh exit (SRX) or power-down exit (PDX), or reset exit	$t_{CKSRX}$	MIN = greater of (5CK, 10ns)							
<b>Power-Down Timing</b>									
Exit power-down with DLL on to any valid command	$t_{XP}$	MIN = greater of 4CK or 6ns							
Exit precharge power-down with DLL frozen to commands not requiring a locked DLL when CA Parity is enabled.	$t_{XP\_PAR}$	MIN = (greater of 4CK or 6ns) + PL							
CKE MIN pulse width	$t_{CKE}$ (MIN)	MIN = greater of 3CK or 5ns							
Command pass disable delay	$t_{CPDED}$	5	-	5	-	6	-		
Power-down entry to power-down exit timing	$t_{PD}$	MIN = $t_{CKE}$ (MIN); MAX = 9 x $t_{REFI}$							
Begin power-down period prior to CKE registered HIGH	$t_{ANPD}$	WL - 1CK							
Power-down entry period: ODT either synchronous or asynchronous	PDE	Greater of $t_{ANPD}$ or $t_{RFC}$ - REFRESH command to CKE LOW time							
Power-down exit period: ODT either synchronous or asynchronous	PDX	$t_{ANPD} + t_{XSDLL}$							
<b>Power-Down Entry Minimum Timing</b>									

**Table 150: Electrical Characteristics and AC Timing Parameters (Continued)**

Parameter	Symbol	DDR4-2666		DDR4-2933		DDR4-3200		Reserved	
		Min	Max	Min	Max	Min	Max	Min	Max
ACTIVATE command to power-down entry	<sup>t</sup> ACTPDEN	2	-	2	-	2	-		
PRECHARGE/PRECHARGE ALL command to power-down entry	<sup>t</sup> PRPDEN	2	-	2	-	2	-		
REFRESH command to power-down entry	<sup>t</sup> REFPDEN	2	-	2	-	2	-		
MRS command to power-down entry	<sup>t</sup> MRSPDEN	MIN = <sup>t</sup> MOD (MIN)							
READ/READ with auto precharge command to power-down entry	<sup>t</sup> RDPDEN	MIN = RL + 4 + 1							
WRITE command to power-down entry (BL8OTF, BL8MRS, BC4OTF)	<sup>t</sup> WRPDEN	MIN = WL + 4 + <sup>t</sup> WR/ <sup>t</sup> CK(AVG)							
WRITE command to power-down entry (BC4MRS)	<sup>t</sup> WRPBC4DEN	MIN = WL + 2 + <sup>t</sup> WR/ <sup>t</sup> CK(AVG) CK							
WRITE with auto precharge command to power-down entry (BL8OTF, BL8MRS, BC4OTF)	<sup>t</sup> WRAPDEN	MIN = WL + 4 + WR + 1							
WRITE with auto precharge command to power-down entry (BC4MRS)	<sup>t</sup> WRAPBC4DEN	MIN = WL + 2 + WR + 1							
<b>ODT Timing</b>									
Direct ODT turn-on latency	DODTLon	WL - 2 = CWL + AL + PL - 2							
Direct ODT turn-off latency	DODTLoff	WL - 2 = CWL + AL + PL - 2							
R <sub>TT</sub> dynamic change skew	<sup>t</sup> ADC	0.3	0.7	0.3	0.7	0.3	0.7		
Asynchronous R <sub>TT(NOM)</sub> turn-on delay (DLL off)	<sup>t</sup> AONAS	1	9	1	9	1	9		
Asynchronous R <sub>TT(NOM)</sub> turn-off delay (DLL off)	<sup>t</sup> AOFAS	1	9	1	9	1	9		
ODT HIGH time with WRITE command and BL8	ODTH8 1 <sup>t</sup> CK	6	-	6	-	6	-		
	ODTH8 2 <sup>t</sup> CK	7	-	7	-	7	-		
ODT HIGH time without WRITE command or with WRITE command and BC4	ODTH4 1 <sup>t</sup> CK	4	-	4	-	4	-		
	ODTH4 2 <sup>t</sup> CK	5	-	5	-	5	-		
<b>Write Leveling Timing</b>									
First DQS <sub>t</sub> , DQS <sub>c</sub> rising edge after write leveling mode is programmed	<sup>t</sup> WLMRD	40	-	40	-	40	-		

**Table 150: Electrical Characteristics and AC Timing Parameters (Continued)**

Parameter	Symbol	DDR4-2666		DDR4-2933		DDR4-3200		Reserved	
		Min	Max	Min	Max	Min	Max	Min	Max
DQS <sub>t</sub> , DQS <sub>c</sub> delay after write leveling mode is programmed	<sup>t</sup> WLDQSEN	25	–	25	–	25	–		
Write leveling setup from rising CK <sub>t</sub> , CK <sub>c</sub> crossing to rising DQS <sub>t</sub> , DQS <sub>c</sub> crossing	<sup>t</sup> WLS	0.13	–	0.13	–	0.13	–		
Write leveling hold from rising DQS <sub>t</sub> , DQS <sub>c</sub> crossing to rising CK <sub>t</sub> , CK <sub>c</sub> crossing	<sup>t</sup> WLH	0.13	–	0.13	–	0.13	–		
Write leveling output delay	<sup>t</sup> WLO	0	9.5	0	9.5	0	9.5		
Write leveling output error	<sup>t</sup> WLOE	0	2	0	2	0	2		
<b>Gear-Down Timing</b>									
Exit reset from CKE HIGH to a valid MRS gear-down	<sup>t</sup> XPR_GEAR	<sup>t</sup> XPR		<sup>t</sup> XPR		<sup>t</sup> XPR		<sup>t</sup> XPR	
CKE HIGH assert to gear-down enable (time)	<sup>t</sup> XS_GEAR	<sup>t</sup> XS		<sup>t</sup> XS		<sup>t</sup> XS		<sup>t</sup> XS	
MRS command to sync pulse time	<sup>t</sup> SYNC_GEAR	<sup>t</sup> MOD + 4CK		<sup>t</sup> MOD + 4CK		<sup>t</sup> MOD + 4CK		<sup>t</sup> MOD + 4CK	
Sync pulse to first valid command	<sup>t</sup> CMD_GEAR	<sup>t</sup> MOD		<sup>t</sup> MOD		<sup>t</sup> MOD		<sup>t</sup> MOD	
Gear-down setup time	<sup>t</sup> GEAR_setup	2CK	–	2CK	–	2CK	–	2CK	–
Gear-down hold time	<sup>t</sup> GEAR_hold	2CK	–	2CK	–	2CK	–	2CK	–

- Notes:
1. Maximum limit not applicable.
  2.  $t_{CCD\_L}$  and  $t_{DLLK}$  should be programmed according to the value defined per operating frequency.
  3. Data rate is less than or equal to 1333 Mb/s.
  4. Data rate is less than or equal to TBD.
  5. WRITE-to-READ when CRC and DM are both not enabled.
  6. WRITE-to-READ delay when CRC and DM are both enabled.
  7. The start of internal write transactions is defined as follows:
    - For BL8 (fixed by MRS and on-the-fly): rising clock edge four clock cycles after WL
    - For BC4 (on-the-fly): rising clock edge four clock cycles after WL
    - For BC4 (fixed by MRS): rising clock edge two clock cycles after WL
  8. For these parameters, the device supports  $t_{nPARAM} [nCK] = RU\{t_{PARAM} [ns]/t_{CK}(AVG) [ns]\}$ , in clock cycles, assuming all input clock jitter specifications are satisfied.
  9. Although unlimited row accesses to the same row is allowed within the refresh period, excessive row accesses to the same row over a long term can result in degraded operation.
  10. When operating in  $1t_{CK}$  WRITE preamble mode.
  11. When operating in  $2t_{CK}$  WRITE preamble mode.
  12. When CA parity mode is selected and the DLLoff mode is used, each REF command requires an additional "PL" added to  $t_{RFC}$  refresh time.
  13. DRAM devices should be evenly addressed when being accessed. Disproportionate accesses to a particular row address may result in reduction of the product lifetime and/or reduction in data retention ability.
  14. Applicable from  $t_{CK} (AVG) MIN$  to  $t_{CK} (AVG) MAX$  as stated in the Speed Bin tables.
  15. JEDEC specifies a minimum of five clocks.
  16. The maximum read postamble is bound by  $t_{DQSCK}(MIN)$  plus  $t_{QSH}(MIN)$  on the left side and  $t_{HZ}(DQS)MAX$  on the right side.
  17. The reference level of DQ output signal is specified with a midpoint as a widest part of output signal eye, which should be approximately  $0.7 \times V_{DDQ}$  as a center level of the static single-ended output peak-to-peak swing with a driver impedance of 34 ohms and an effective test load of 50 ohms to  $V_{TT} = V_{DDQ}$ .

## EDY4016 Option and Exception Lists

### Mode Register Settings

The EDY4016 has certain features not supported as might be suggested in the datasheet. The datasheet states features and operations that are speed bin dependant may not be supported or available on die if not required for that speed bin, however, the following list some of these as well.

- MR0 [13,11:9] 0111 = Reserved (WR/RTP of 22/11 Clocks not available)
- MR0 [13,11:9] 1000 = Reserved (WR/RTP of 26/13 Clocks not available)
- MR0 [12,6:4,2] 01100 = Reserved (CL23 not supported)
- MR0 [12,6:4,2] 1XXXX = Reserved (CL25 through CL32 not available)
- MR1 [2:1] 10 = Reserved (40 ohm ODI not available)
- MR4 [4] 1 = Reserved (sPPR not available)
- MR4 [13] 1 = Reserved (PPR not available)

### Options Tables

**Table 151: Die Revision Options**

Function	Acronym	Rev. A
Write leveling	WL	Yes
Temperature controlled refresh	TCR	Yes
Low-power auto self refresh	LPASR	Yes
Fine granularity refresh	FGR	Yes
Multipurpose register	MR	Yes
Data mask	DM	Yes
Data bus inversion	DBI	Yes
TDQS	–	Yes
ZQ calibration	ZQ CAL	Yes
V <sub>REFDQ</sub> calibration	–	Yes
Per-DRAM addressability	Per DRAM	Yes
Mode register readout	–	Yes
Command/Address latency	CAL	Yes
Write CRC	CRC	Yes
CA parity	–	Yes
Gear-down mode	–	N/A
Programmable preamble	–	Pending
Maximum power-down mode	–	Yes
Connectivity test mode	CT	Yes
Additive latency	AL	Yes
Target row refresh mode	TRR	N/A
Post package repair mode	PPR	Pending

**Table 151: Die Revision Options (Continued)**

Function	Acronym	Rev. A
Soft post package repair mode	sPPR	Pending

**Table 152: Speed Options**

Function	Acronym	Data Rate					
		1600	1866	2133	2400	2666	3200
Write leveling	WL	Yes	Yes	Yes	Yes	Yes	Yes
Temperature controlled refresh	TCR	Yes	Yes	Yes	Yes	Yes	Yes
Low-power auto self refresh	LPASR	Yes	Yes	Yes	Yes	Yes	Yes
Fine granularity refresh	FGR	Yes	Yes	Yes	Yes	Yes	Yes
Multipurpose register	MR	Yes	Yes	Yes	Yes	Yes	Yes
Data mask	DM	Yes	Yes	Yes	Yes	Yes	Yes
Data bus inversion	DBI	Yes	Yes	Yes	Yes	Yes	Yes
TDQS	–	Yes	Yes	Yes	Yes	Yes	Yes
ZQ calibration	ZQ CAL	Yes	Yes	Yes	Yes	Yes	Yes
V <sub>REFDQ</sub> calibration	–	Yes	Yes	Yes	Yes	Yes	Yes
Per-DRAM addressability	Per DRAM	Yes	Yes	Yes	Yes	Yes	Yes
Mode register readout	–	Yes	Yes	Yes	Yes	Yes	Yes
Command/Address latency	CAL	Yes	Yes	Yes	Yes	Yes	Yes
Write CRC	CRC	Yes	Yes	Yes	Yes	Yes	Yes
CA parity	–	Yes	Yes	Yes	Yes	Yes	Yes
Gear-down mode	–	No	No	No	No	Yes	Yes
Programmable preamble	–	No	No	No	Yes	Yes	Yes
Maximum power-down mode	–	Yes	Yes	Yes	Yes	Yes	Yes
Connectivity test mode	CT	Yes	Yes	Yes	Yes	Yes	Yes
Additive latency	AL	Yes	Yes	Yes	Yes	Yes	Yes
Target row refresh mode	TRR	Yes	Yes	Yes	Yes	Yes	Yes
Post package repair mode	PPR	Yes	Yes	Yes	Yes	Yes	Yes
Soft post package repair mode	sPPR	Yes	Yes	Yes	Yes	Yes	Yes

**Table 153: Width Options**

Function	Acronym	Width			Density			
		x4	x8	x16	4Gb	8Gb	12Gb	16Gb
Write leveling	WL	Yes	Yes	Yes	Yes	Yes	Yes	Yes
Temperature controlled refresh	TCR	Yes	Yes	Yes	Yes	Yes	Yes	Yes
Low-power auto self refresh	LPASR	Yes	Yes	Yes	Yes	Yes	Yes	Yes
Fine granularity refresh	FGR	Yes	Yes	Yes	Yes	Yes	Yes	Yes
Multipurpose register	MR	Yes	Yes	Yes	Yes	Yes	Yes	Yes

**Table 153: Width Options (Continued)**

Function	Acronym	Width			Density			
		x4	x8	x16	4Gb	8Gb	12Gb	16Gb
Data mask	DM	No	Yes	Yes	Yes	Yes	Yes	Yes
Data bus inversion	DBI	No	Yes	Yes	Yes	Yes	Yes	Yes
TDQS	–	No	Yes	No	Yes	Yes	Yes	Yes
ZQ calibration	ZQ CAL	Yes	Yes	Yes	Yes	Yes	Yes	Yes
V <sub>REFDQ</sub> calibration	–	Yes	Yes	Yes	Yes	Yes	Yes	Yes
Per-DRAM addressability	Per DRAM	Yes	Yes	Yes	Yes	Yes	Yes	Yes
Mode register readout	–	Yes	Yes	Yes	Yes	Yes	Yes	Yes
Command/Address latency	CAL	Yes	Yes	Yes	Yes	Yes	Yes	Yes
Write CRC	CRC	Yes	Yes	Yes	Yes	Yes	Yes	Yes
CA parity	–	Yes	Yes	Yes	Yes	Yes	Yes	Yes
Gear-down mode	–	Yes	Yes	Yes	Yes	Yes	Yes	Yes
Programmable preamble	–	Yes	Yes	Yes	Yes	Yes	Yes	Yes
Maximum power-down mode	–	Yes	Yes	No	Yes	Yes	Yes	Yes
Connectivity test mode	CT	Yes	Yes	Yes	Optional	Yes	Yes	Yes
Additive latency	AL	Yes	Yes	Yes	Yes	Yes	Yes	Yes
Target row refresh mode	TRR	Yes	Yes	Yes	Yes	Yes	Yes	Yes
Post package repair mode	PPR	Yes	Yes	Yes	Optional	Yes	Yes	Yes
Soft post package repair mode	sPPR	Yes	Yes	Yes	Optional	Optional	Yes	Yes

8000 S. Federal Way, P.O. Box 6, Boise, ID 83707-0006, Tel: 208-368-4000

[www.micron.com/products/support](http://www.micron.com/products/support) Sales inquiries: 800-932-4992



Micron and the Micron logo are trademarks of Micron Technology, Inc.

All other trademarks are the property of their respective owners.

This data sheet contains minimum and maximum limits specified over the power supply and temperature range set forth herein. Although considered final, these specifications are subject to change, as further product development and data characterization sometimes occur.

## Looking for pricing, stock, or lifecycle information?

Click below to explore more details on WIN SOURCE:

-  [View MT40A256M16LY-062E IT:F TR on WIN SOURCE](#)
-  [Micron Technology Inc. Information](#)

## Optimize Your Supply Chain with WIN SOURCE Solutions

-  Global Sourcing Solution
-  Obsolete Management
-  Cost Control Management
-  Shortage Management
-  Alternative Solution
-  Excess Inventory Management