



# MAX16841

## Controller IC for Dimmable Offline LED Lamps

### General Description

The MAX16841 is an LED driver for AC line (100V, 120V, 220V, and 230V AC) input lamps. It features proprietary control of the input current that allows lamps to dim smoothly from full to zero light intensity, while providing active power factor correction (PFC). It is a very flexible product that can be used in isolated (e.g., flyback) and nonisolated (e.g., buck) configurations. The conventional use of an optocoupler in isolated configurations can be avoided in MAX16841-based designs.

The constant frequency-control technique of the device allows maximization of the conversion efficiency at both low and high AC line by operating at the conduction mode that minimizes total conduction and switching losses.

The device can be configured for universal input (90V to 264V AC) dimmable applications, allowing the design of an LED lamp that can be operated and dimmed worldwide.

This device can be used without electrolytic capacitors, thus maximizing the lamp lifetime. In this case, the LED current is a rectified sinusoid with a frequency that is twice the AC line frequency.

The device also features thermal shutdown, current limit, open LED protection, and  $V_{CC}$  undervoltage lockout. The MAX16841 is available in an 8-pin SO package and operates over the  $-40^{\circ}\text{C}$  to  $+125^{\circ}\text{C}$  temperature range.

### Applications

Retrofit LED Lamps with Triac Dimming  
Universal Input LED Retrofit Lamps  
Industrial and Commercial Lighting  
Residential LED Lighting

### Features

- ◆ Smooth Dimming with Leading-Edge (Triac) and Trailing-Edge Dimmers
- ◆ Active Power Factor Correction
- ◆ Nonisolated (e.g., Buck) and Isolated (e.g., Flyback) Topologies
- ◆ Universal 90V to 264V AC Input Range
- ◆ Constant Frequency-Control Scheme Maximizes Efficiency at High and Low AC Line Voltage
- ◆ Constant Power Control with No Need for Optocouplers
- ◆ Very-Low Quiescent Current
- ◆ Output Open and Short Protection
- ◆ Thermal Shutdown
- ◆ Available in an 8-Pin SO Package

*[Ordering Information](#) appears at end of data sheet.*

*[Typical Operating Circuits](#) appear at end of data sheet.*

*For related parts and recommended products to use with this part, refer to [www.maximintegrated.com/MAX16841.related](http://www.maximintegrated.com/MAX16841.related).*

## Controller IC for Dimmable Offline LED Lamps

### ABSOLUTE MAXIMUM RATINGS

IN to GND.....	-0.3V to +26V	Operating Temperature Range.....	-40°C to +125°C
NDRV, $\overline{\text{DIMOUT}}$ to GND .....	-0.3V to ( $V_{\text{IN}} + 0.3\text{V}$ )	Junction Temperature .....	+150°C
All Other Pins to GND .....	-0.3V to +6V	Storage Temperature Range.....	-65°C to +150°C
NDRV Continuous Current .....	$\pm 10\text{mA}$	Lead Temperature (soldering, 10s) .....	+300°C
$\overline{\text{DIMOUT}}$ Continuous Current .....	$\pm 2\text{mA}$	Soldering Temperature (reflow) .....	+260°C
Continuous Power Dissipation ( $T_{\text{A}} = +70^{\circ}\text{C}$ )			
8 SO (derate 7mW/°C above +70°C) .....	588.2mW		

Stresses beyond those listed under "Absolute Maximum Ratings" may cause permanent damage to the device. These are stress ratings only, and functional operation of the device at these or any other conditions beyond those indicated in the operational sections of the specifications is not implied. Exposure to absolute maximum rating conditions for extended periods may affect device reliability.

### PACKAGE THERMAL CHARACTERISTICS (Note 1)

8 SO			
Junction-to-Ambient Thermal Resistance ( $\theta_{\text{JA}}$ ) (based on S8+2) .....	136°C/W	Junction-to-Case Thermal Resistance ( $\theta_{\text{JC}}$ ) (based on S8+2) .....	38°C/W

**Note 1:** Package thermal resistances were obtained using the method described in JEDEC specification JESD51-7, using a four-layer board. For detailed information on package thermal considerations, refer to [www.maximintegrated.com/thermal-tutorial](http://www.maximintegrated.com/thermal-tutorial).

### ELECTRICAL CHARACTERISTICS

( $V_{\text{IN}} = 12\text{V}$ ,  $T_{\text{A}} = T_{\text{J}} = -40^{\circ}\text{C}$  to  $+125^{\circ}\text{C}$ , unless otherwise noted. Typical values are at  $T_{\text{A}} = +25^{\circ}\text{C}$ .) (Note 2)

PARAMETER	SYMBOL	CONDITIONS	MIN	TYP	MAX	UNITS
IN Operating Range	$V_{\text{IN}}$		11		20	V
IN Undervoltage Threshold	UVLORIN	$V_{\text{IN}}$ rising, $V_{\text{HYST}} = 1\text{V}$	9.5	10	10.5	V
IN Overvoltage Threshold	OVLORIN	$V_{\text{IN}}$ rising, $V_{\text{HYST}} = 1.8\text{V}$	21	22	23	V
IN Input Supply Current	I <sub>IN</sub>	NDRV not switching, $V_{\text{TH}} = 0\text{V}$	0.7	1.3	2.6	mA
		NDRV switching, 177.5k $\Omega$ /330pF on NDRV, $V_{\text{TH}} = 5\text{V}$ , $V_{\text{COMP}} = 2\text{V}$ , $V_{\text{CS}} = 0\text{V}$ , $V_{\text{REFI}} = 2.35\text{V}$	1.7	2.7	4.2	
		$V_{\text{IN}} = 8\text{V}$		1.6		
<b>TH</b>						
TH Operating Range			0		4	V
TH Threshold Voltage	$V_{\text{TH}}$	$V_{\text{TH}}$ rising, hysteresis = 150mV	1.17	1.215	1.26	V
TH Input Supply Current		$V_{\text{TH}} = 0\text{V}$		0.16	0.3	$\mu\text{A}$
<b>REFI</b>						
REFI Operating Range	$V_{\text{REFI}}$		0.5		3.25	V
REFI Input Supply Current		$V_{\text{REFI}} = 2\text{V}$	48.5	50	51.5	$\mu\text{A}$
<b><math>\overline{\text{DIMOUT}}</math></b>						
$\overline{\text{DIMOUT}}$ On-Resistance		$\overline{\text{DIMOUT}} = \text{IN}$		20	40	$\Omega$
		$\overline{\text{DIMOUT}} = \text{GND}$		20	40	
TH to $\overline{\text{DIMOUT}}$ Propagation Delay		$V_{\text{TH}}$ rising		40	80	ns
		$V_{\text{TH}}$ falling		40	80	
<b>INTERNAL OSCILLATOR</b>						
Oscillator Frequency		$R_{\text{T}} = 47.5\text{k}\Omega$		50		kHz
		$R_{\text{T}} = 177.5\text{k}\Omega$	160	180	200	
		$R_{\text{T}} = 297.5\text{k}\Omega$	270	300	330	

# MAX16841

## Controller IC for Dimmable Offline LED Lamps

### ELECTRICAL CHARACTERISTICS (continued)

( $V_{IN} = 12V$ ,  $T_A = T_J = -40^{\circ}C$  to  $+125^{\circ}C$ , unless otherwise noted. Typical values are at  $T_A = +25^{\circ}C$ .) (Note 2)

PARAMETER	SYMBOL	CONDITIONS	MIN	TYP	MAX	UNITS
RT Resistance Range			47.5		297.5	k $\Omega$
Oscillator Decode Resolution				6		Bits
Dither Frequency Range		45kHz to 330kHz		1.875		%
Frequency Dither Ramping DAC				7		Bits
Dither Frequency				1.5		kHz
<b>CURRENT SENSE</b>						
CS Input Bias Current		VCS = 2V, VCOMP = 4V	-1	0	+1	$\mu$ A
		VCS = 2V, VCOMP = 0.7V	60	90	130	
CS Voltage at Current Limit	VCS_LIMIT		2.1	2.2	2.3	V
CS Voltage at Current Limit Soft-Start				10		ms
CS Voltage at Hiccup Current Limit			2.6	2.7	2.8	V
CS Hiccup Shutdown		CS > hiccup		1.2		s
Hiccup Detection Cycles				3		Times
CS Regulation Voltage		VCOMP = 2V, VREFI = 2.35V, VCS = 0.45V	448	450	462	mV
<b>TRANSCONDUCTANCE AMPLIFIER</b>						
Transconductance	Gm	VCOMP = 2.2V, VREFI = 2.35V, VCS = 0.45V $\pm$ 0.05V	95	135	175	$\mu$ S
COMP Sink Current	ISINK	VCOMP = 2V, VREFI = 2.35V, VCS = 0V	45	65	85	$\mu$ A
COMP Source Current	ISOURCE	VCOMP = 2V, VREFI = 2.35V, VCS = 0.9V	45	65	85	$\mu$ A
<b>NDRV</b>						
NDRV Operating Range			0		V <sub>IN</sub>	V
NDRV On-Resistance		INDRV = 50mA to 100mA		2	5.0	$\Omega$
		INDRV = -50mA to -100mA		1.25	2.5	
NDRV Dead Time		Rising or falling		5		Ns
NDRV Rise Time		NDRV = 1nF, 10% to 90%		15		ns
NDRV Fall Time		NDRV = 1nF, 90% to 10%		15		ns
NDRV Reference Current		Startup only	7.5	8	8.5	$\mu$ A
<b>THERMAL SHUTDOWN</b>						
Thermal-Shutdown Threshold		T <sub>J</sub> rising		164		$^{\circ}C$
Thermal Hysteresis				20		$^{\circ}C$

**Note 2:** All parameters are tested at  $T_A = +25^{\circ}C$  only. Limits over temperature are guaranteed by design.

# MAX16841

## Controller IC for Dimmable Offline LED Lamps

### Typical Operating Characteristics

( $T_A = T_J = +25^\circ\text{C}$ , 12 series LED load.)

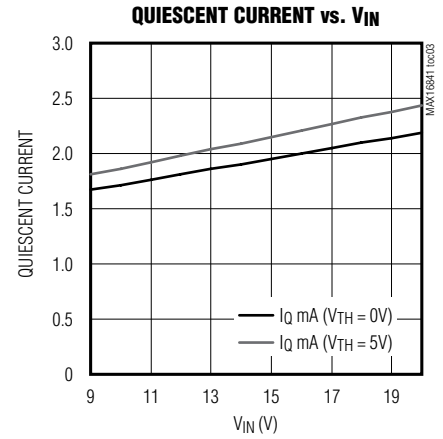
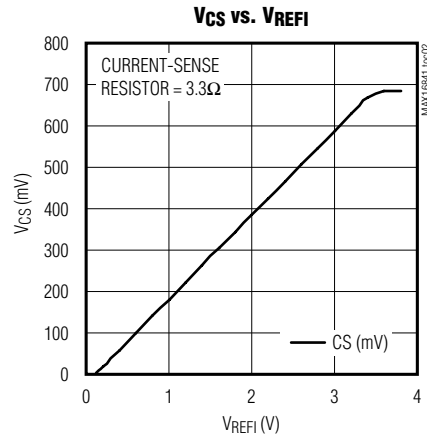
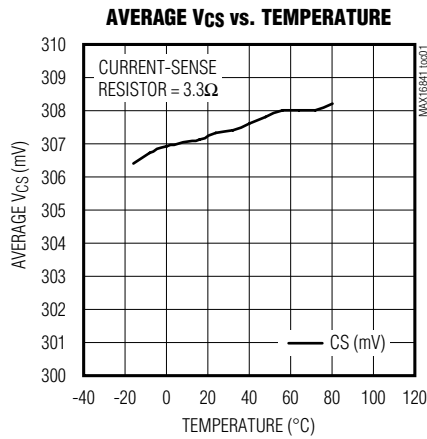

# MAX16841

## Controller IC for Dimmable Offline LED Lamps

### Pin Configuration

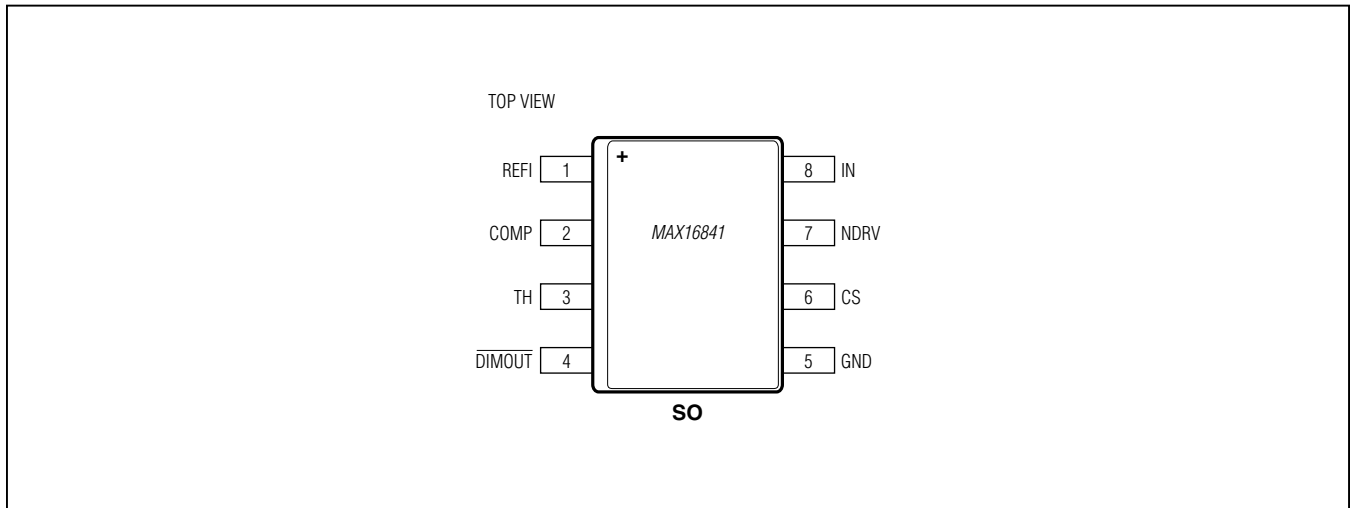

### Pin Description

PIN	NAME	FUNCTION
1	REFI	Current Reference Input. The IC sources 50 $\mu$ A current out of this pin. Connect a resistor from REFI to GND to set the input-current reference.
2	COMP	Compensation Component Connection for the Switching Stage. Connect a suitable RC network to ground. This is the output of the $G_m$ amplifier.
3	TH	Sets the Voltage Threshold on the Input at Which Switching Starts. This threshold is set at 1.24V. Connect a resistor-divider from the bridge rectifier output, TH, and GND.
4	$\overline{\text{DIMOUT}}$	$\overline{\text{DIMOUT}}$ Drives an External FET to Provide a Resistive Path for the Triac when Input is Low. $\overline{\text{DIMOUT}}$ is also used to drive an external FET that sets the programmed current to zero when the input voltage is low.
5	GND	Ground
6	CS	Switch Current-Sense Input
7	NDRV	Gate Drive for the Switching MOSFET. Connect a resistor across NDRV and GND to set the switching frequency.
8	IN	Input. Bypass with a 0.1 $\mu$ F or a higher value ceramic capacitor to ground.

# MAX16841

## Controller IC for Dimmable Offline LED Lamps

### Functional Diagram

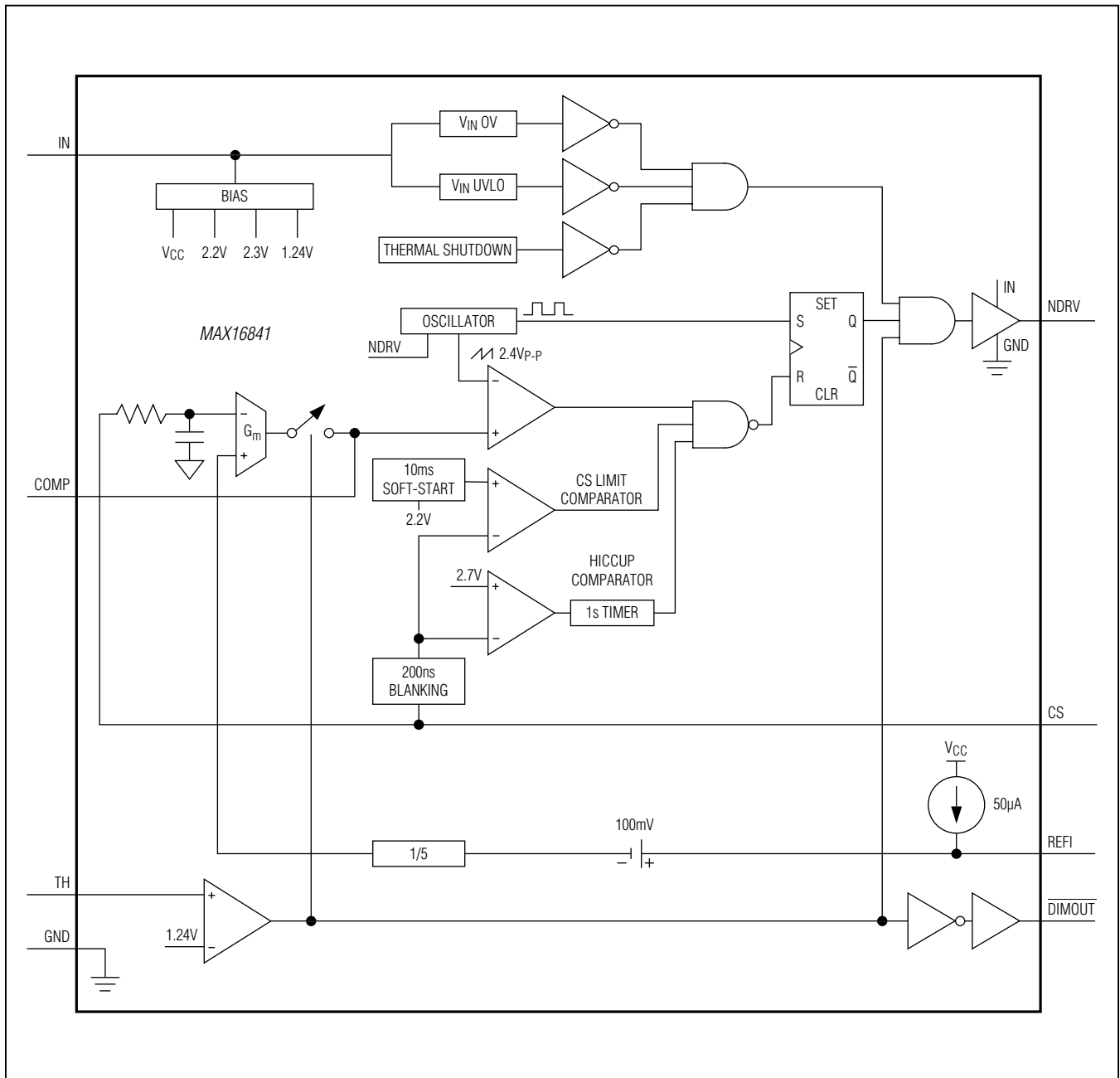

## Controller IC for Dimmable Offline LED Lamps

### **Detailed Description**

### **DIMOUT**

The MAX16841 is a fixed-frequency offline LED driver IC that is compatible with both leading-edge triac dimmers and trailing-edge transistor dimmers. The device uses a fixed-frequency average current-mode control scheme to control the switching current in the MOSFET. In addition, a peak-limit comparator is used to limit the peak switching current during overload and transient conditions. The peak-limit comparator has a threshold of 2.2V. For the active PFC, the device uses a proprietary current-control scheme where the averaged switch current on a cycle-by-cycle basis is set to a programmed DC value. This maximizes the efficiency of the converter by operating in continuous-conduction mode (CCM) at low AC line voltage (100V to 120V) and in discontinuous-conduction mode (DCM) at high AC line voltage (220V to 240V). Switching is initiated when the voltage on the TH pin exceeds a threshold of 1.24V. In the case of the buck configuration, the  $V_{TH}$  falling threshold should be set in such a way so that the input voltage exceeds the maximum forward voltage of the LED string. In the case of the buck-boost or flyback configuration, this threshold can be set lower.

The device also uses a proprietary current-sense scheme to regulate the LED current.

The device switching frequency is adjustable from 50kHz to 300kHz using a single resistor from NDRV to ground. The device operates over a wide 11V to 20V supply voltage. The device's switching MOSFET gate driver sources and sinks up to 1A, making it capable of driving high-voltage MOSFETs in offline LED driver applications for power ranges up to 25W. The device allows for dimming with leading-edge and trailing-edge dimmers.

Additional features include thermal shutdown and overvoltage protection.

### **IN**

The device is powered up by the voltage at IN. All the internal regulators derive power from IN. The operational voltage is between 11V and 20V.

### **TH**

TH sets the threshold for switching. Switching is initiated once TH crosses 1.24V. The TH comparator has a 150mV hysteresis. In a buck configuration, the  $V_{TH}$  falling threshold should be set in such a way so that the input voltage exceeds the maximum forward voltage of the LED string. In a buck-boost configuration, the  $V_{TH}$  falling threshold can be set to a lower level.

For proper operation with triac dimmers, the load connected to the dimmer should draw at least the startup current when the dimmer is in the off state. For proper operation of the timing circuit of the dimmer, there should always be a close-current path. To ensure this, a bleeder resistor is connected across IN and GND with the help of an external FET. DIMOUT drives this external FET on when  $V_{TH}$  goes below the falling threshold. The bleeder resistor is disconnected when  $V_{TH}$  crosses its rising threshold, resulting in better performance and efficiency.

### **Internal Oscillator**

The internal oscillator of the device is programmable from 50kHz to 300kHz. Connect a single resistor from NDRV to GND to set the oscillator frequency. Upon power-up, an 8 $\mu$ A of current sinks into this resistor. An internal ramp is then compared against the voltage on NDRV to determine the oscillator frequency.

### **Frequency Dithering**

The device incorporates a frequency-dithering feature. This feature helps to reduce EMI.

### **n-Channel MOSFET Switch Driver (NDRV)**

The NDRV driver drives the gate of an external n-channel switching MOSFET. NDRV switches between IN and GND. NDRV is capable of sourcing/sinking 1A of peak current, allowing the device to switch MOSFETs in an offline LED driver application. The average current drawn from the supply to drive the external MOSFET depends on the MOSFET gate charge and switching frequency. Use the following equation to calculate the MOSFET driver supply current:

$$I_{NDRV} = Q_G \times f_{SW}$$

### **Switching MOSFET Current Sense (CS)**

The switching MOSFET current-sense resistor should be connected to the CS pin of the device. The device controls the average of the CS signal to a level determined by the REF1 voltage. Internal leading-edge blanking of 200ns (typ) is provided to avoid premature turn-off of the switching MOSFET in each switching cycle. A peak-limit comparator is used to limit the peak switch current during overload and transient conditions. The peak-limit comparator has a threshold of 2.2V (typ).

## Controller IC for Dimmable Offline LED Lamps

### **Input-Current Setting (REFI)**

REFI is the external reference for programming the input current of the LED driver. The input current is proportional to the REFI voltage. The IC sources 50 $\mu$ A current out of this pin and the voltage at the REFI pin can also be set by connecting a resistor from REFI to GND. Internally, the REFI signal is downshifted by 100mV and then attenuated by a factor of 5. The attenuated signal is applied to the positive terminal of the internal error amplifier and this signal sets the reference for the controller.

### **Error-Amplifier Output (COMP)**

The device includes an internal transconductance current error amplifier with a typical  $G_m$  of 150 $\mu$ S. The output of the error amplifier is controlled by the TH comparator output. When the TH comparator is high, the output of the error amplifier connects to COMP. When the TH comparator is low, the error amplifier is disconnected from COMP, preserving the charge on the compensation capacitor. COMP is connected to the positive terminal of the PWM comparator.

The device incorporates an average current-mode control scheme to regulate the input current. The control loop regulates the average of the CS signal to a level determined by the REFI voltage. The control loop consists of the current-sense resistor ( $R_{CS}$ ) connected across CS and GND, the transconductance current error amplifier, an oscillator providing a 2.4V ramp at switching frequency, the control voltage on the positive input of the  $G_m$  amplifier, and the PWM comparator.

### **Overvoltage-Protection Input (OVP)**

This is the protection feature in a flyback converter during an open LED condition. The IN pin is connected to the auxiliary winding of the flyback transformer. During an open LED condition, the IN voltage increases and NDRV is disabled once the IN voltage reaches 22.5V (typ). When the IN voltage drops by 2V, NDRV is enabled.

### **Short-Circuit Protection**

During an output short condition, the inductor current keeps increasing with input voltage as there is no negative voltage across the inductor during the off period of the switching cycle. During this condition, the CS voltage signal peak is at a higher level because the inductor current is at a higher level than during the normal condition. Once the CS signal exceeds the hiccup threshold of 2.7V (typ), the internal hiccup block gets activated. Switching is disabled for 1s (typ) if CS exceeds 2.7V (typ) for three times.

### **Thermal Protection**

The device enters into thermal-shutdown mode when junction temperature exceeds +160°C. During thermal shutdown, NDRV is disabled. The device recovers from thermal-shutdown mode once the junction temperature drops by 20°C.

### **Applications Information**

Figure 1 shows a MAX16841-based, triac-dimmable, PFC, nonisolated-buck offline LED driver. Components L1, L2, L3, and C1 provide EMI filtering. During the turn-on instant of triac dimming, there would be significant ringing due to high inrush current to charge the input capacitor (C9). The ringing could cause the line current to fall to zero and this would turn off the triac. R3, R22, and C14 act as a damper and help to limit the inrush current and ringing. Due to R3, the efficiency of the supply decreases. The damper circuit can be omitted in nondimming applications. The circuit, consisting of D4, R5, C2, D3, R6, R4, and Q5, bypasses R3 with Q1 after 1ms of dimming instant, thereby reducing the power dissipation in R3 and improving efficiency. During the turn-on instant, capacitor C2 is charged by a constant-current source formed by D3, R6, R4, and Q5. Within 1ms time, sufficient voltage develops across C2 to fire the SCR Q1. Diode D4 provides fast discharge of C2. Resistors R8, R9, and R10 program the switching threshold. The rising threshold should be set at a voltage higher than the maximum LED string voltage. When the input voltage is below the falling threshold,  $\overline{\text{DIMOUT}}$  drives the Q3 FET on, connecting R7 across the diode-bridge positive and GND. Thus, a close circuit is formed for the timing circuit of the triac. Diode D2 blocks capacitors C9 and C14 to discharge through R7. This helps to reduce the inrush current during the triac turn-on instant.

The circuit consisting of R23, R24, D6, and Q2 is a linear regulator and provides bias to the device.

The buck-converter circuit is formed by C9, LED+, LED-, C10, L5, Q4, D10, D11, and R20. Capacitor C9 provides a path for the switching frequency currents. Maximum value of this capacitor is limited by the input power-factor requirements. The higher the value of C9, the lower the input power factor.

Since the input-voltage waveform to the buck converter is a rectified sinusoid at line frequency, the LED current has a ripple at double-line frequency. Electrolytic capacitors C11 and C12 filter this double-line frequency ripple.



## Controller IC for Dimmable Offline LED Lamps

### Resistors R16 and R20

The average current in resistor R16 is the average input current of the buck converter.

If  $P_{OUT}$  is the output power, then the input power is given by:

$$P_{IN} = \frac{P_{OUT}}{\eta}$$

$$I_{IN} = \frac{P_{IN} \times \pi}{2 \times V_M}$$

$$V_M = \sqrt{2} \times V_{INrms}$$

$$R16 = \frac{I_{IN} \times R20 + 0.1V}{10\mu A}$$

$$R_{CS} = \frac{V_{CS} \times 80\%}{I_{LP}}$$

$$I_{LP} = I_{IN} + 0.5 \times \Delta I_{Lmax}$$

$I_{LP}$  is the switch peak current. Maximum peak in the switch current occurs at the peak level of the highest input voltage.

$V_{CS}$  is 2.2V. Allow 80% margin for tolerances.

### Inductor Selection

For optimum efficiency, inductor L5 must be operated in continuous-conduction mode.

The current in the inductor would be at its maximum level at peak of the highest input voltage. LED string voltage is assumed constant. Calculate the duty cycle at peak of the highest input voltage.

$$D = \frac{V_{LED}}{\sqrt{2} \times V_{INmax}}$$

The percentage peak-to-peak ripple is considered between 30% and 60% of the inductor current. Assuming 60% peak-to-peak inductor current ripple, the maximum inductor current is given by:

$$I_{Lmax} = \frac{P_{OUT} \times \pi}{2 \times V_{LED}}$$

The minimum value of the inductor is given by:

$$L_{min} = \frac{(\sqrt{2} \times V_{INmax} - V_{LED}) \times D}{0.6 \times I_{Lmax} \times f_{SW}}$$

Figure 2 shows a PFC triac, dimmable, isolated (flyback topology) offline LED driver.

Here the current through the Q4 MOSFET is controlled. Current through Q4 is the same as the input current of the flyback converter. The input-side circuitry is the same as in the nonisolated buck LED driver that was previously described. During startup, the device is powered up from Q2, R10, R11, and D8. Bootstrap from the bias winding on the transformer turns off the Q2 MOSFET, thus saving power from high-voltage line. Here the switching threshold programmed by R15, R16, and R18 can be lower than the LED string voltage.

Output-side electrolytic capacitors C8 and C9 are used for filtering the double-line frequency current ripple in LED current.

During an open LED condition, the voltage across the output capacitors increases and is reflected on the bias-winding side.

Once the bias-winding voltage goes above 22.5V (typ), NDRV is disabled and the Q4 MOSFET turns off.

Choose the transformer turns ratio based on the voltage rating of the MOSFET. Use the following expression to calculate primary-secondary turns ratio:

$$N_{PS} = \frac{0.8 \times V_{DSmax} - V_{INmax}}{V_{LEDmax}}$$

where:

$N_{PS}$  is the primary-secondary turns ratio

$V_{DSmax}$  is the voltage rating of the Q4 MOSFET

$V_{INmax}$  is the maximum peak input voltage

$V_{LEDmax}$  is the maximum voltage of the LED string

Factor 0.8 is taken into account for the voltage spikes, due to transformer-leakage inductance.

Use the following equation to calculate bias-secondary turns ratio:

$$N_{AS} = \frac{18V}{V_{LEDmax}}$$

where  $N_{AS}$  is the bias-secondary turns ratio and 18V is the bias voltage for the device.



## Controller IC for Dimmable Offline LED Lamps

Choose the transformer's magnetizing inductance ( $L_m$ ) in such a way so that the transformer operates in DCM above 120V AC input. DCM operation at higher voltages reduces switching losses in the Q4 MOSFET. Use the following equation to calculate  $L_m$ :

$$L_m = \frac{170V \times D^2}{I_{IN} \times f_{SW} \times 2}$$

$$I_{IN} = \frac{P_{IN} \times \pi}{340V}$$

where  $D$  is the switching duty cycle at 170V DC and  $f_{SW}$  is the switching frequency.

In DCM conditions, the peak current in  $L_m$  can be calculated with the help of the following equation:

$$I_P = \sqrt{\frac{2 \times I_{IN} \times V_{INmax}}{L_m \times f_{SW}}}$$

where  $V_{INmax}$  is the maximum peak input voltage.

### **Feedback Compensation** **Loop Compensation for Nonisolated Buck (R17, C3, C4)**

The switching converter small-signal transfer function contains a pole at origin and a zero. The zero location is inversely related to inductor current and inductance value. The minimum frequency of the zero location is:

$$f_{Zmin} = \frac{V_{LED}}{2 \times \pi \times L \times I_{Lmax}}$$

Design the loop compensation in such a way so that the loop crossover is near  $f_{Zmin}$ . Place the compensation zero formed by R17 and C4 at  $f_{Zmin}/5$ . R20 is given by:

$$R17 = \frac{I_{Lmax} \times R20}{G_m \times V_{P-P}}$$

$$C4 = \frac{5}{2 \times \pi \times f_{Zmin} \times R17}$$

where  $G_m$  is the transconductance of the internal error amplifier and  $V_{P-P}$  is 2.4V.

Place the compensation pole formed by R17 and C3 at  $5 \times f_{Zmin}$ :

$$C3 = \frac{1}{2 \times \pi \times 5 \times f_{Zmin} \times R17}$$

### **Loop Compensation for Flyback Driver (R17, C3, C4)**

The switching converter small-signal transfer function is identical to the buck transfer function. The zero location is inversely related to primary-magnetizing inductance and its current. The minimum frequency of the zero location is:

$$f_{Zmin} = \frac{V_{LED}}{2 \times \pi \times L_m \times I_{Lmax}} \times \frac{N_P}{N_S}$$

Design the loop compensation in such a way so that the loop crossover is near  $f_{Zmin}$ . Place the compensation zero formed by R17 and C4 at  $f_{Zmin}/5$ . R20 is given by:

$$R17 = \frac{I_{Lmax} \times R20}{G_m \times V_{P-P}}$$

$$C4 = \frac{5}{2 \times \pi \times f_{Zmin} \times R17}$$

where  $L_m$  is the magnetizing inductance of the flyback transformer,  $G_m$  is the transconductance of the internal error amplifier, and  $V_{P-P}$  is 2.4V.

Place the compensation pole formed by R17 and C3 at  $5 \times f_{Zmin}$ :

$$C3 = \frac{1}{2 \times \pi \times 5 \times f_{Zmin} \times R17}$$

## Controller IC for Dimmable Offline LED Lamps

### **Layout Recommendations**

Careful PCB layout is critical to achieve low switching losses, and clean, stable operation. The switching-converter portion of the circuit has nodes with very fast voltage changes that could lead to undesirable effects on the sensitive parts of the circuit.

Follow the guidelines below to reduce noise as much as possible:

- 1) Ensure that all heat-dissipating components have adequate cooling.
- 2) Isolate the power components and high-current paths from the sensitive analog circuitry.
- 3) Have a power ground plane for the switching-converter power circuit under the power components (input filter capacitor, output filter capacitor, inductor, MOSFET, rectifier diode, and current-sense resistor). Connect GND to the power ground plane as close as possible to GND. Connect all other ground connections to the power ground plane using vias close to the terminals
- 4) There are two loops in the power circuit that carry high-frequency switching currents. One loop is when the MOSFET is on (from the input filter capacitor positive terminal, through the output capacitor, inductor, switching MOSFET, and current-sense resistor, to the input capacitor negative terminal). The other loop is when the MOSFET is off (from the output capacitor negative terminal, through the inductor, the rectifier diode, and output filter capacitor positive terminal). Analyze these two loops and make the loop areas as small as possible. Wherever possible, have a return path on the power ground plane for the switching currents on the top-layer copper traces or through power components. This reduces the loop area considerably and provides a low-inductance path for the switching currents. Reducing the loop area also reduces radiation during switching.

# MAX16841

## Controller IC for Dimmable Offline LED Lamps

### Typical Operating Circuits

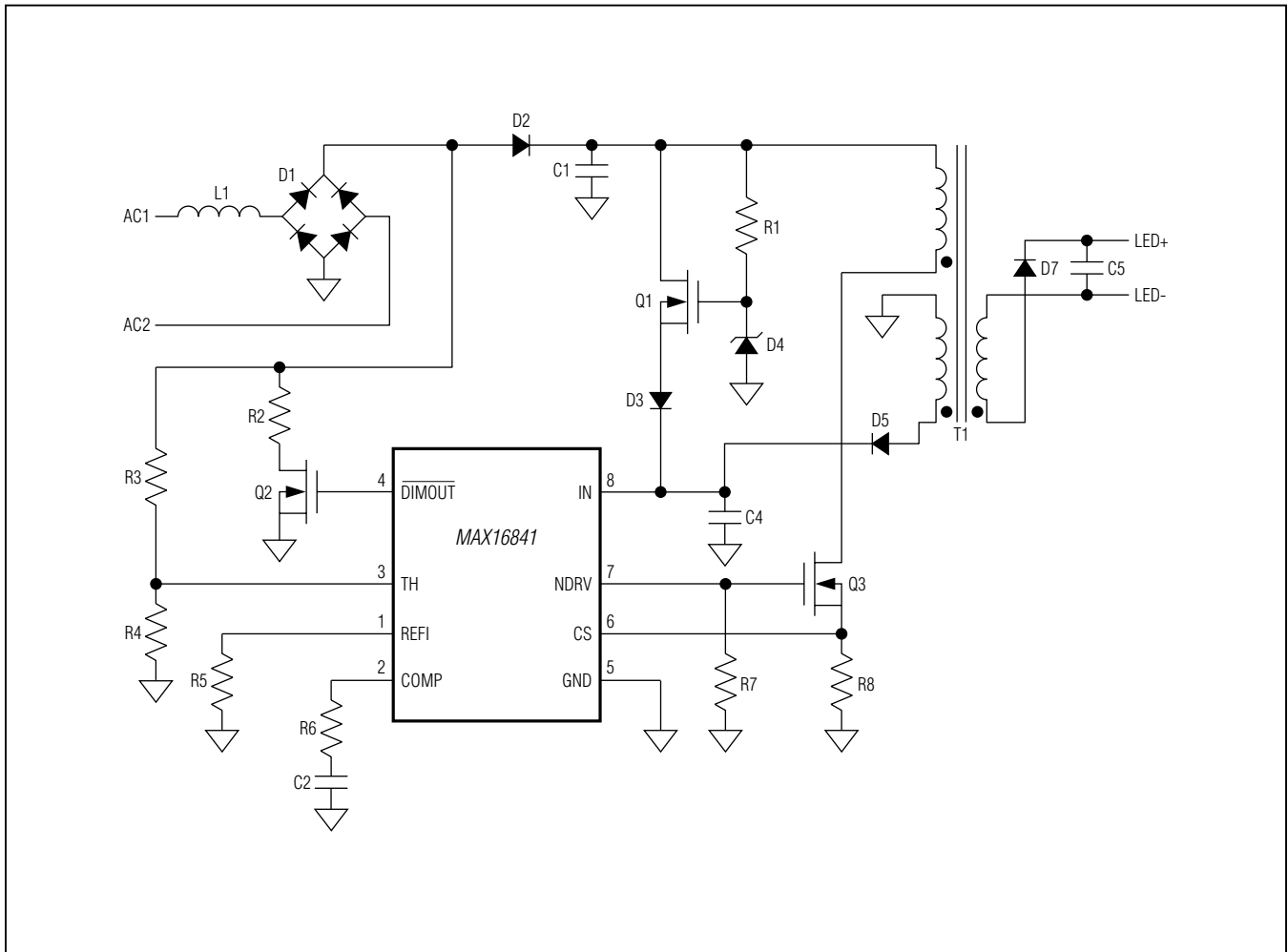

Figure 3. Flyback LED Driver

# MAX16841

## Controller IC for Dimmable Offline LED Lamps

### Typical Operating Circuits (continued)

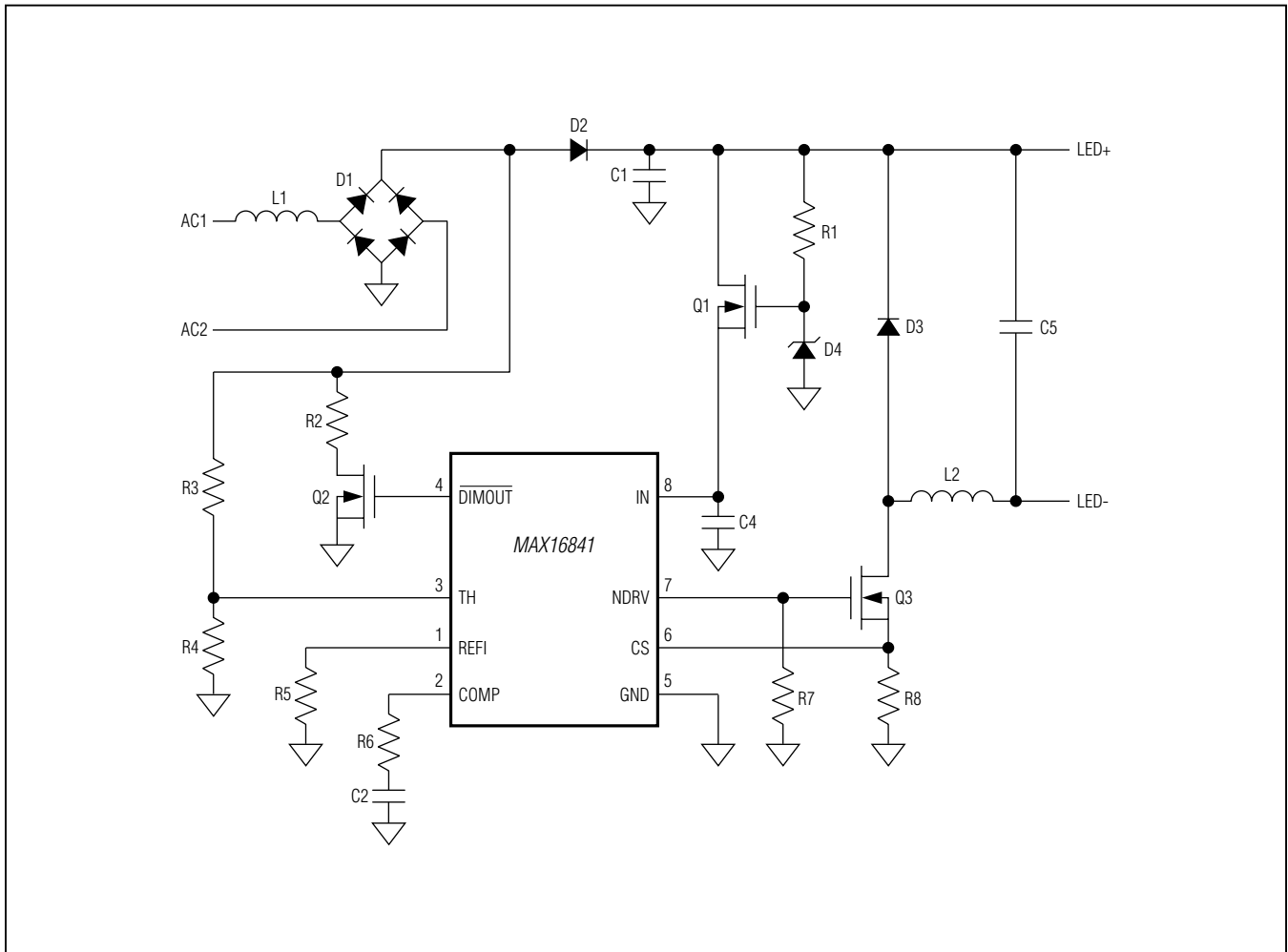

Figure 4. Buck LED Driver

# MAX16841

## Controller IC for Dimmable Offline LED Lamps

### Typical Operating Circuits (continued)

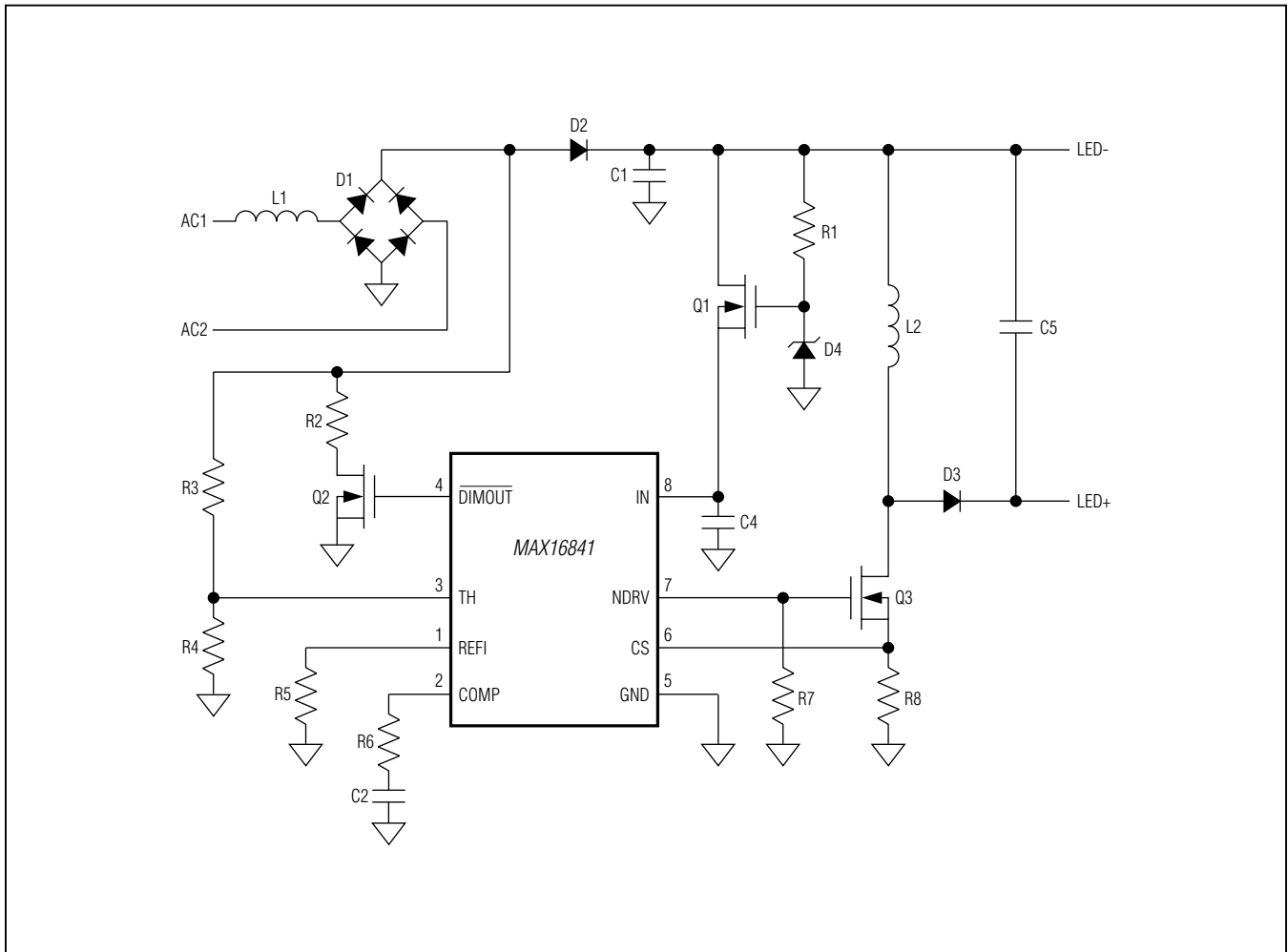

Figure 5. Buck-Boost LED Driver

# MAX16841

## Controller IC for Dimmable Offline LED Lamps

### Ordering Information

PART	TEMP. RANGE	PIN-PACKAGE
MAX16841ASA+	-40°C to +125°C	8 SO

+Denotes a lead(Pb)-free/RoHS-compliant package.

### Chip Information

PROCESS: BiCMOS

### Package Information

For the latest package outline information and land patterns (footprints), go to [www.maximintegrated.com/packages](http://www.maximintegrated.com/packages). Note that a "+", "#", or "-" in the package code indicates RoHS status only. Package drawings may show a different suffix character, but the drawing pertains to the package regardless of RoHS status.

PACKAGE TYPE	PACKAGE CODE	OUTLINE NO.	LAND PATTERN NO.
8 SO	S8+2	<a href="#">21-0041</a>	<a href="#">90-0096</a>

# MAX16841

## Controller IC for Dimmable Offline LED Lamps

### Revision History

REVISION NUMBER	REVISION DATE	DESCRIPTION	PAGES CHANGED
0	10/11	Initial release	—
1	6/13	Corrected CS regulation voltage unit in <i>Electrical Characteristics</i> table	3



Maxim Integrated cannot assume responsibility for use of any circuitry other than circuitry entirely embodied in a Maxim Integrated product. No circuit patent licenses are implied. Maxim Integrated reserves the right to change the circuitry and specifications without notice at any time. The parametric values (min and max limits) shown in the Electrical Characteristics table are guaranteed. Other parametric values quoted in this data sheet are provided for guidance.

**Maxim Integrated 160 Rio Robles, San Jose, CA 95134 USA 1-408-601-1000**

18

## Looking for pricing, stock, or lifecycle information?

Click below to explore more details on WIN SOURCE:

- ⊖ [View MAX16841ASA+T on WIN SOURCE](#)
- ⊖ [Maxim Integrated Information](#)

## Optimize Your Supply Chain with WIN SOURCE Solutions

- ✓ Global Sourcing Solution
- ✓ Obsolete Management
- ✓ Cost Control Management
- ✓ Shortage Management
- ✓ Alternative Solution
- ✓ Excess Inventory Management