

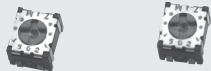

THE DATASHEET OF ST-2TA101



RoHS compliant



FEATURES

- RoHS compliant
- Compact and low-profile □2 mm single turn type
- Sealed construction
- Resin materials are UL Recognized 94V-0 or 94V-1 equivalent

INTERNAL STRUCTURE

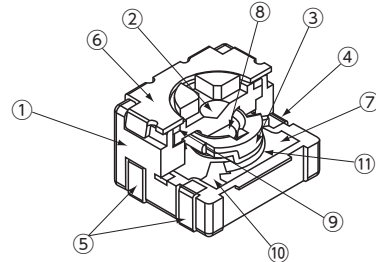

	Part name	Material
①	Housing	Epoxy
②	Rotor	PPS (Polyphenylenesulphide)
③	Wiper	Stainless steel (SUS 304)
④	Terminal #2	Copper alloy, Sn-Cu-plated
⑤	Terminal #1, #3	
⑥	Cover	Stainless steel (SUS 304)
⑦	Substrate	Ceramic
⑧	Pin	Blass, Sn-plated
⑨	“O” ring	Silicone rubber
⑩	Terminations	Ag-Pd cermet
⑪	Resistive element	RuO ₂ cermet

PART NUMBER DESIGNATION

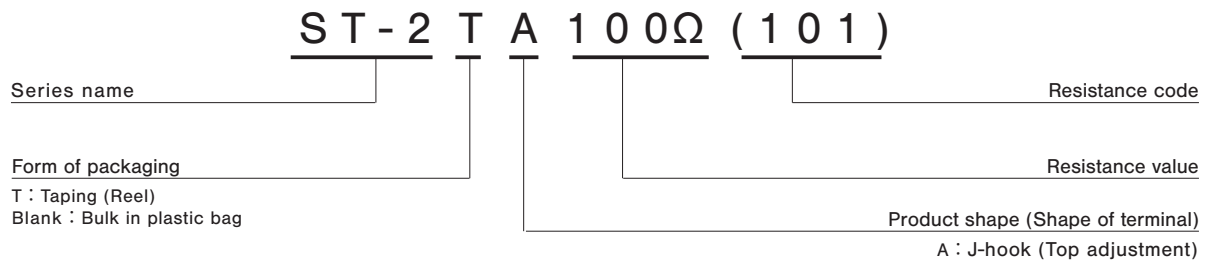

※ Please refer to the LIST OF PART NUMBERS when placing orders.

ST-2

SURFACE MOUNT TRIMMERS

LIST OF PART NUMBERS

Adjustment position	Shape of terminal	Form of packaging	
		Taping (reel)	Plastic bag
Top adjustment	A (J-hook)	ST-2TA	ST-2A
Pieces in package		500 pcs./reel	100 pcs./pack

〈Nominal resistance values〉

100 Ω	200 Ω	500 Ω	1 kΩ	2 kΩ	5 kΩ	10 kΩ
20 kΩ	50 kΩ	100 kΩ	200 kΩ	500 kΩ	1 MΩ	

Fig.1

- ※ The part numbers on the left are all available with the respective combination of <Nominal resistance values> (Fig. 1).
- ※ Verify the above part numbers when placing orders.
- ※ Taping version is not sold separately and must be purchased in reel units.

ELECTRICAL CHARACTERISTICS

Nominal resistance range	100 Ω ~ 1 MΩ
Resistance tolerance	± 20 %
Power ratings	0.1 W (70 °C) 0 W (125 °C)
Resistance law	Linear law (B)
Maximum input voltage	DC50 V or power rating, whichever is smaller
Maximum wiper current	Within power ratings ($I = \sqrt{P/R}$ A)
Effective electrical angle	240 ° (1 turn)
End resistance	1 % or 2 Ω, whichever is greater
C.R.V.	2 % or 3 Ω, whichever is greater
Operating temp. range	-55 ~ 125 °C
Temp. coefficient	± 150 10 ⁻⁶ /°C
Insulation resistance	1000 MΩ minimum (DC500 V)
Dielectric strength	AC500 V, 60 s
Net weight	Approx. 0.032 g

MECHANICAL CHARACTERISTICS

Mechanical angle	270 ° (1 turn)
Operating torque	5 mN·m {51 gf·cm} maximum
Stop strength	8 mN·m {78.4 gf·cm} minimum
Rotational life	50 cycles [$\Delta R/R \leq \pm (2 \Omega + 5 \%)$]
Thrust to rotor	3 N {0.31 kgf} minimum
Solderability	245 ± 3 °C, 2 ~ 3 s
Shear (Adhesion)	5 N {0.51 kgf} 10 s
Substrate bending	Width 90 mm, bend 3 mm, 5 s, 1 time
Pull-off strength	5 N {0.51 kgf} 10 s

{ } : Reference only

ST-2

SURFACE MOUNT TRIMMERS

ENVIRONMENTAL CHARACTERISTICS

Test item	Test conditions	Specifications
Thermal shock	-65 ~ 125 °C (0.5 h), 5 cycles	[$\Delta R/R \leq 2\%$ [S.S. $\leq 2\%$]
Humidity	-10 ~ 65 °C (Relative humidity 80 ~ 98 %), 10 cycles, 240 h	[$\Delta R/R \leq 2\%$]
Shock	981 m/s ² , 6 ms 6 directions for 3 times each	[$\Delta R/R \leq 2\%$ [S.S. $\leq 1\%$]
Vibration	Amplitude 1.52 mm or Acceleration 196 m/s ² , 10 ~ 2000 Hz, 3 directions, 12 times each	
Load life	70 °C, 0.1 W 1000 h	[$\Delta R/R \leq 3\%$ [S.S. $\leq 1\%$]
Low temp. operation	-55 °C, 2 h	[$\Delta R/R \leq 2\%$ [S.S. $\leq 2\%$]
High temp. exposure	125 °C, 250 h	[$\Delta R/R \leq 3\%$ [S.S. $\leq 2\%$]
Immersion seal	85 °C, 60 s	No leaks (No continuous bubbles)
Soldering heat	Reflow Peak temperature : 255 °C (Please refer to the profile below) Flow soldering : 260 ± 3 °C, 5 ~ 6 s, two times maximum Manual soldering : 350 ± 10 °C, 3 ~ 4 s	[$\Delta R/R \leq \pm 1\%$]

$\Delta R/R$: Change in total resistance
S.S. : Setting stability

<Reflow profile for soldering heat evaluation>

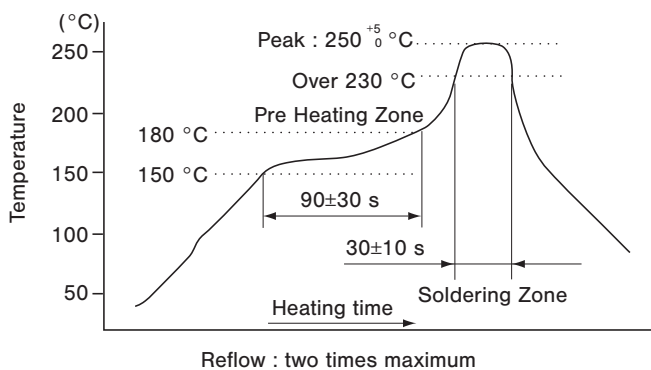

MAXIMUM INPUT RATINGS

Nominal resistance values (Ω)	Resistance code	Maximum input voltage (V)	Maximum wiper current (mA)
100	101	3.16	31.6
200	201	4.47	22.4
500	501	7.07	14.1
1 k	102	10.0	10.0
2 k	202	14.1	7.1
5 k	502	22.3	4.5
10 k	103	31.6	3.2
20 k	203	44.7	2.2
50 k	503	50.0	1.0
100 k	104	50.0	0.5
200 k	204	50.0	0.25
500 k	504	50.0	0.1
1 M	105	50.0	0.05

RECOMMENDED P.C.B. PAD OUTLINE DIMENSIONS

(Unit : mm)

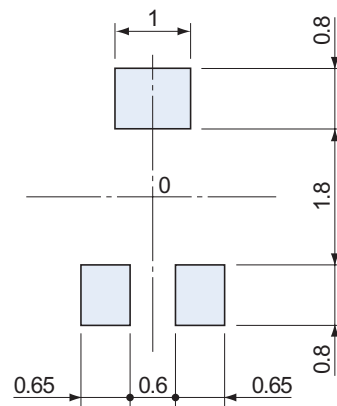

Note) The zero point is the center of mounting.

ST-2

SURFACE MOUNT TRIMMERS

OUTLINE DIMENSIONS

ST-2A

Top adjustment

Unless otherwise specified, tolerance : ± 0.3 (Unit : mm)

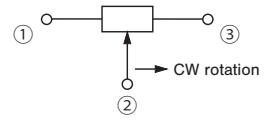

※ Note the terminal position.

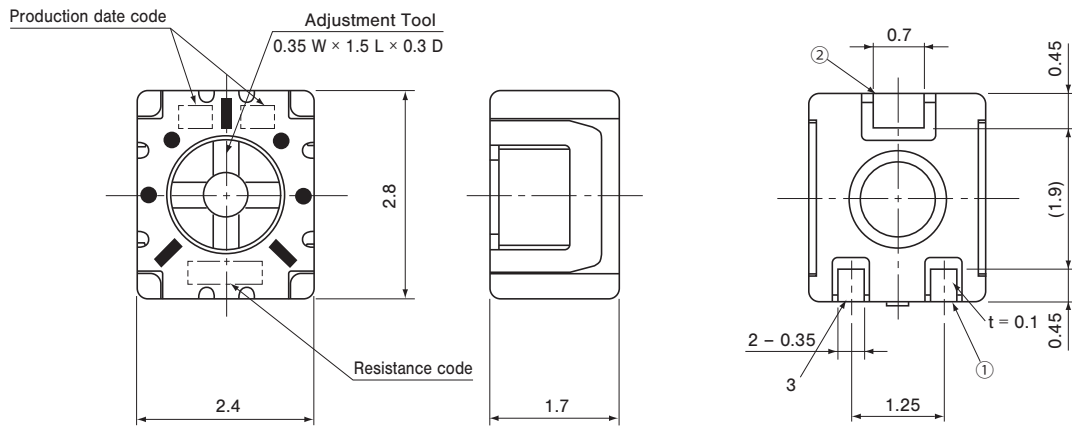

ST-2/ST-32 ADJUSTMENT TOOL

● Compliant with two models (ST-2/ST-32)

Recommended models	
ST-32	ST-2

Material : Polyoxymethylene

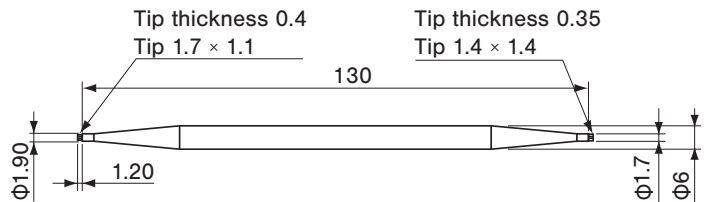

For ST-32

For ST-2

Recommended screwdrivers for use

Manufacturer	Model
ENGINEER INC.	DA-54

※ Note : Please do not use the tool for purposes other than adjustment of electronic components.

ST-2

SURFACE MOUNT TRIMMERS

PACKAGING SPECIFICATIONS

<Taping packaging specifications>

- Taping version is packaged in 500 pcs. per reel.
Orders will be accepted for units of 500 pcs., i.e., 500, 1000, 1500 pcs., etc.
- Taping version is boxed with one reel (500 pcs.).
Maximum number of consecutive missing pieces=2
Leader length and reel dimension are shown in the diagrams below.

EMBOSED TAPE DIMENSIONS

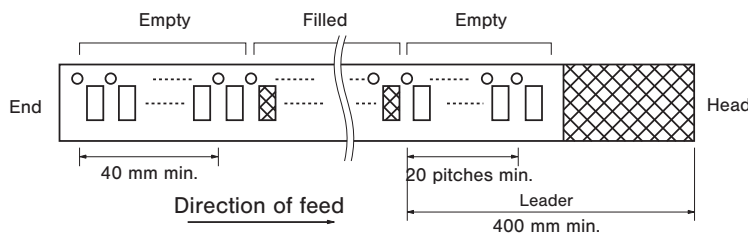

REEL DIMENSIONS

(Conforms to JIS C 0806-3)
(In accordance with EIAJ ET-7200A)

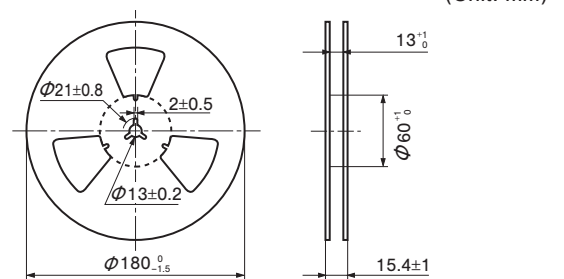

ST-2TA

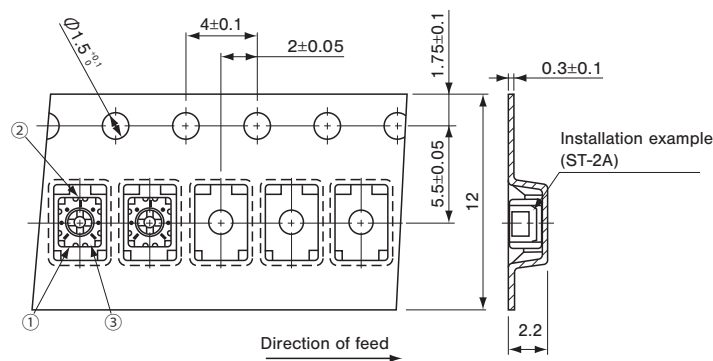



<Bulk pack specifications>

- Unit of bulk in a plastic bag is 100 pcs. per pack.
- Boxing of bulk in a plastic bag is performed with 500 pcs. per box.

Looking for pricing, stock, or lifecycle information?

Click below to explore more details on WIN SOURCE:

-  [View ST-2TA101 on WIN SOURCE](#)
-  [Nidec Copal Electronics Information](#)

Optimize Your Supply Chain with WIN SOURCE Solutions

-  Global Sourcing Solution
-  Obsolete Management
-  Cost Control Management
-  Shortage Management
-  Alternative Solution
-  Excess Inventory Management