



**THE DATASHEET OF
MAX25400GTC/V+**



MAX25400

Automotive Hi-Speed USB 2.0 Protector

General Description

The MAX25400 device provides high-ESD and short-circuit protection for the low-voltage internal USB data and USB power line in automotive radio, navigation, connectivity, and USB hub applications. The device supports USB Hi-Speed (480Mbps), USB full-speed (12Mbps), and USB low-speed (1.5Mbps) operation. The short-circuit protection features include short-to-BUS and short-to-battery on the protected HVD+ and HVD-, and include a fault output.

The device features high-ESD protection to $\pm 15\text{kV}$ Air Gap and $\pm 8\text{kV}$ Contact on the protected HVD+ and HVD- outputs. The device features two low on-resistance (R_{ON}) USB 2.0 data switches.

The MAX25400 is available in a 12-pin lead-free, TQFN-EP package and operate over the -40°C to 105°C temperature range.

Applications

- Automotive USB Protection

Benefits and Features

- Targeted Features for Optimized USB Performance
 - Two R_{ON} 3.3Ω (typ) USB 2.0 Data Switches
 - 480Mbps, 12Mbps, or 1.5Mbps USB 2.0 Operation
 - 9ms Fault-Recovery Time
- Robust for the Automotive Environment
 - Short-to-Battery and Short-to-BUS Protection on Protected HVD+ and HVD- Outputs
 - Tested to ISO 10605 and IEC 61000-4-2 ESD Standards
 - 12-Pin (3mm x 3mm) TQFN-EP Package
 - -40°C to $+105^{\circ}\text{C}$ Operating Temperature Range
 - AEC-Q100 Qualified

Ordering Information appears at end of datasheet.

Typical Operating Circuit

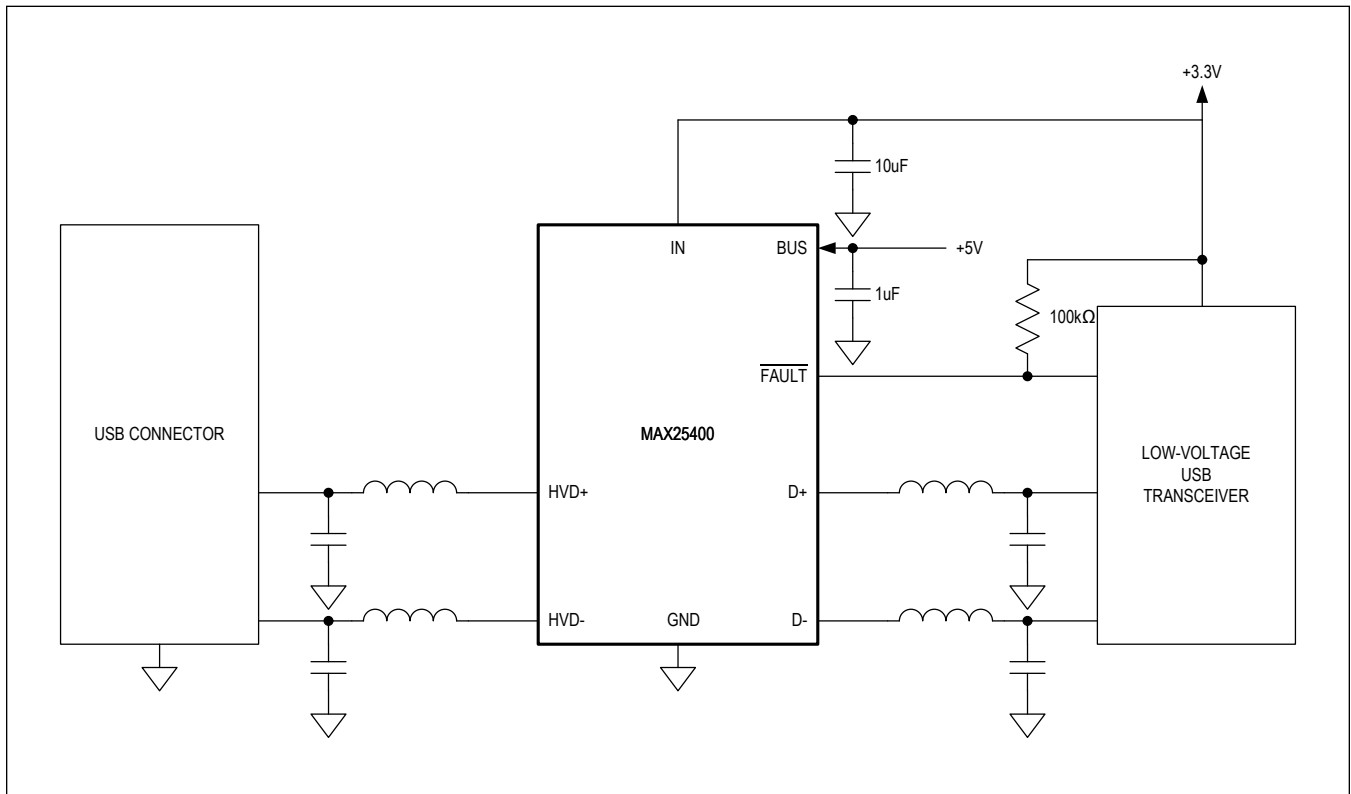

TABLE OF CONTENTS

General Description	1
Applications	1
Benefits and Features	1
Typical Operating Circuit	1
Absolute Maximum Ratings	4
Package Information	4
12-Pin TQFN	4
Electrical Characteristics	4
Typical Operating Characteristics	8
Pin Configuration	9
MAX25400	9
Pin Description	9
Detailed Description	11
BUS Undervoltage Lockout (Power-On Reset)	11
HVD+ and HVD- Overvoltage Protection	11
FAULT Output	11
Applications Information	12
Power-Supply Bypass Capacitor	12
Layout of USB Data Line Traces	12
±25kV ESD Protection	12
ESD Test Conditions	12
Human Body Model	12
IEC 61000-4-2	12
Human Body Test Model	13
Human Body Current Waveform	14
IEC 61000-4-2 ESD Test Model	15
IEC 61000-4-2 ESD Generator Current Waveform	16
Functional Diagram	17
Ordering Information	17
Revision History	18

LIST OF FIGURES

Figure 1. Timing Diagram for Undervoltage Lockout on BUS	6
Figure 2. Timing Diagram for Overvoltage Protection on HVD+, HVD-.	6
Figure 3. On-Channel -3dB Bandwidth and Crosstalk	6
Figure 4. On-Capacitance	7
Figure 5. Propagation Delay and Output Skew	7
Figure 6. Human Body ESD Test Model	13
Figure 7. Human Body Current Waveform	14
Figure 8. IEC 61000-4-2 ESD Test Model.	15
Figure 9. IEC 61000-4-2 ESD Generator Current Waveform	16
Figure 10. Functional Diagram	17

Absolute Maximum Ratings

BUS, IN.....	-0.3V to +6V	Operating Ambient Temperature Range.....	-40°C to +105°C
FAULT, D+, D-.....	-0.3V to +6V	Maximum Junction Temperature	+150°C
D+, D- to IN	+0.3V	Storage Temperature Range	-60°C to +150°C
HVD+, HVD-.....	-0.3V to +18V	Lead Temperature (soldering) (10s).....	+300°C
Continuous Power Dissipation 12-Pin TQFN (Four Layer Board derate 21.3mW/°C above +70°C) (TA = +70°C)	1704mW	Soldering Temperature (reflow)	+260°C

Stresses beyond those listed under "Absolute Maximum Ratings" may cause permanent damage to the device. These are stress ratings only, and functional operation of the device at these or any other conditions beyond those indicated in the operational sections of the specifications is not implied. Exposure to absolute maximum rating conditions for extended periods may affect device reliability.

Package Information

12-Pin TQFN

Package Code	T1233+5C
Outline Number	21-0136
Land Pattern Number	90-0019
THERMAL RESISTANCE, FOUR-LAYER BOARD	
Junction-to-Ambient (θ_{JA})	46.9°C/W
Junction-to-Case Thermal Resistance (θ_{JC})	5.27°C/W

For the latest package outline information and land patterns (footprints), go to www.maximintegrated.com/packages. Note that a "+", "#", or "-" in the package code indicates RoHS status only. Package drawings may show a different suffix character, but the drawing pertains to the package regardless of RoHS status.

Package thermal resistances were obtained using the method described in JEDEC specification JESD51-7, using a four-layer board. For detailed information on package thermal considerations, refer to www.maximintegrated.com/thermal-tutorial.

Electrical Characteristics

($V_{BUS} = 5.0V$, $V_{IN} = +3.3V$, $T_J = T_A = -40°C$ to $+105°C$. $R_L = \infty$, unless otherwise noted. Typical values are at $T_A = +25°C$, unless otherwise noted. (Note 1))

PARAMETER	SYMBOL	CONDITIONS	MIN	TYP	MAX	UNITS
POWER SUPPLY						
Power Supply Range (BUS)	V_{BUS}		4.75		5.5	V
Power Supply Range (IN)	V_{IN}		3.0		3.6	V
BUS Input Current	I_{BUS}	No load, no fault		125		μA
V_{IN} Input Current	I_{IN}	No load, no fault			12	μA
BUS Undervoltage Lockout	V_{UVLO}	V_{BUS} falling (Figure 1)	3.85	4.2	4.55	V
USB DATA SWITCH						
Analog Signal Range			0		3.6	V
Protection-Trip Threshold	V_{OV_D}	HVD+, HVD- rises from V_{IN} to $> V_{IN}+1V$ (Figure 2)			3.9	V

Electrical Characteristics (continued)

($V_{BUS} = 5.0V$, $V_{IN} = +3.3V$, $T_J = T_A = -40^{\circ}C$ to $+105^{\circ}C$. $R_L = \infty$, unless otherwise noted. Typical values are at $T_A = +25^{\circ}C$, unless otherwise noted. (Note 1))

PARAMETER	SYMBOL	CONDITIONS	MIN	TYP	MAX	UNITS
Protection-Recovery Time	t_{FPR_D}	HVD+, HVD- falling to below V_{OV_D} (Figure 2)	6	9	11	ms
Protection-Response Time	t_{FP_D}	HVD+, HVD- rises from V_{IN} to $> V_{IN}+1V$ (Figure 2)		0.5	1	μs
On-Resistance	R_{ON}	$V_{BUS} = 5V$, $I_L = 40mA$, $0 \leq V_D \leq 3.6V$		3.3		Ω
On-Resistance Match Between Channels	ΔR_{ON}	$V_{BUS} = 5V$, $I_L = 40mA$, $V_D = 1.5V, 3.0V$			0.25	Ω
On-Resistance Flatness	$R_{FLAT(ON)}$	$I_L = 40mA$, $V_D = 0V$ or $0.4V$			0.25	Ω
HVD+, HVD- Off-Leakage Current	I_{HVD_OFF}	$V_{HVD+}, V_{HVD-} = 18V$, $V_{D+}, V_{D-} = 0V$			20	μA
		$V_{HVD+}, V_{HVD-} = 18V$, $V_{D+}, V_{D-} = 0V$, $V_{IN} = 0V$, $V_{BUS} = 0V$			20	
HVD+, HVD- On-Leakage Current	I_{HVD_ON}	$V_{HVD+}, V_{HVD-} = V_{IN}$			5	μA
On Channel -3dB Bandwidth	BW	$R_L = 50\Omega$, source Impedance = 50Ω (Figure 5)		864		MHz
FAULT OUTPUT						
FAULT Output Low Voltage	V_{OL}	$I_{SINK} = 500\mu A$			0.5	V
FAULT Output High-Leakage Current					1	μA
FAULT Recovery Time	t_{FPR}	$V_{FAULT} = V_{IN}$ (Figure 3)	6	9	11	ms
ESD PROTECTION D+, D-, BUS, FAULTB, VIN						
ESD Protection Level	V_{ESD}	Human Body Model		± 2		kV
ESD PROTECTION HVD+, HVD-						
ESD Protection Level	V_{ESD}	ISO 10605 Air Gap (330pF, 2k Ω)		± 25		kV
		ISO 10605 Contact (330pF, 2k Ω)		± 8		
		IEC 61000-4-2 Air Gap (150pF, 330 Ω)		± 25		
		IEC 61000-4-2 Contact (150pF, 330 Ω)		± 8		
Thermal Protection						
Thermal Shutdown				165		$^{\circ}C$
Thermal Shutdown Hysteresis				15		$^{\circ}C$

Note 1: Specifications with minimum and maximum limits are 100% production tested at $T_A = +25^{\circ}C$ and are guaranteed over the operating temperature range by design and characterization. Actual typical values may vary and are not guaranteed.

Note 2: Guaranteed by design. Limits are not production tested.

Note 3: Tested in the Typical Application Circuit, as shown on the evaluation kit.

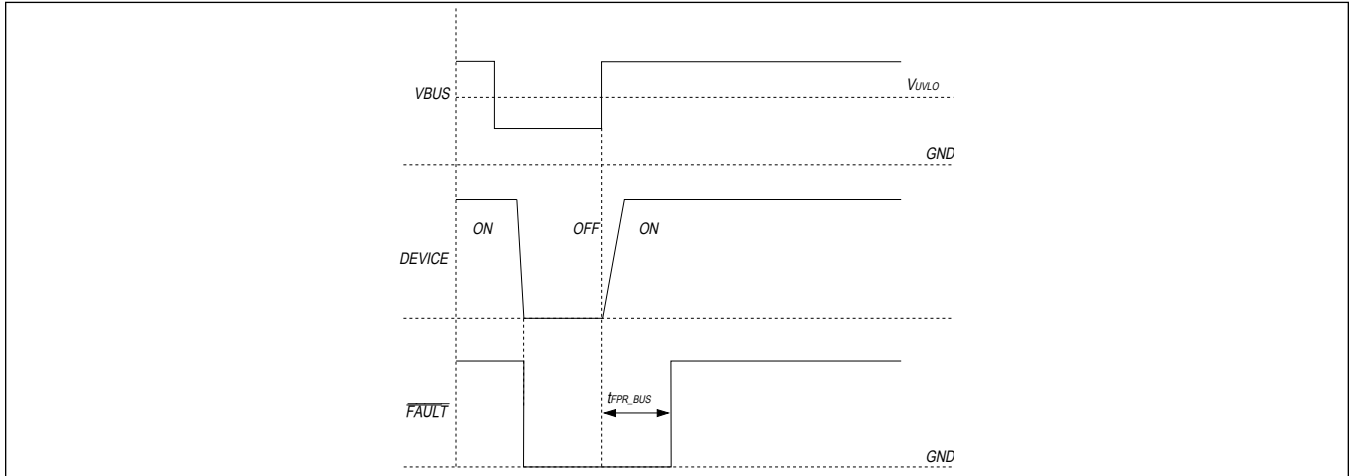

Figure 1. Timing Diagram for Undervoltage Lockout on BUS

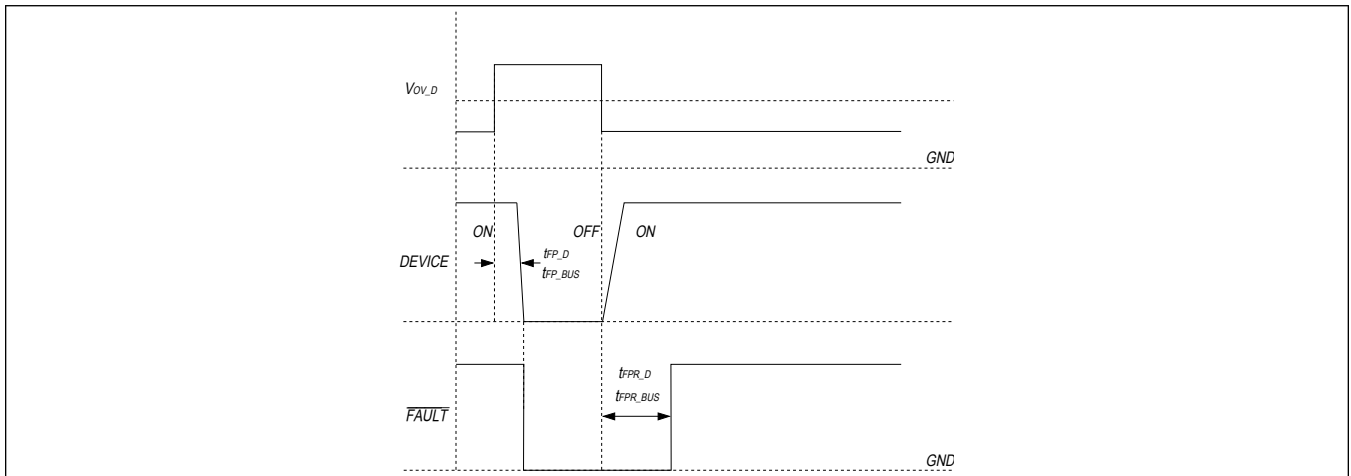

Figure 2. Timing Diagram for Overvoltage Protection on HVD+, HVD-

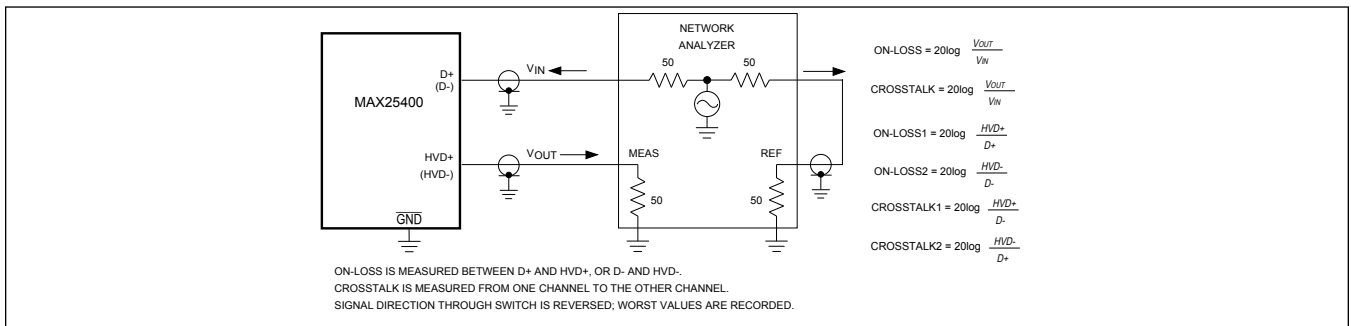

Figure 3. On-Channel -3dB Bandwidth and Crosstalk

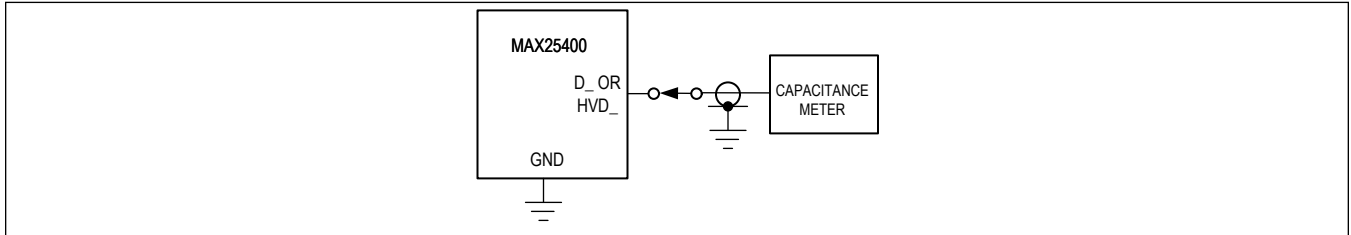

Figure 4. On-Capacitance

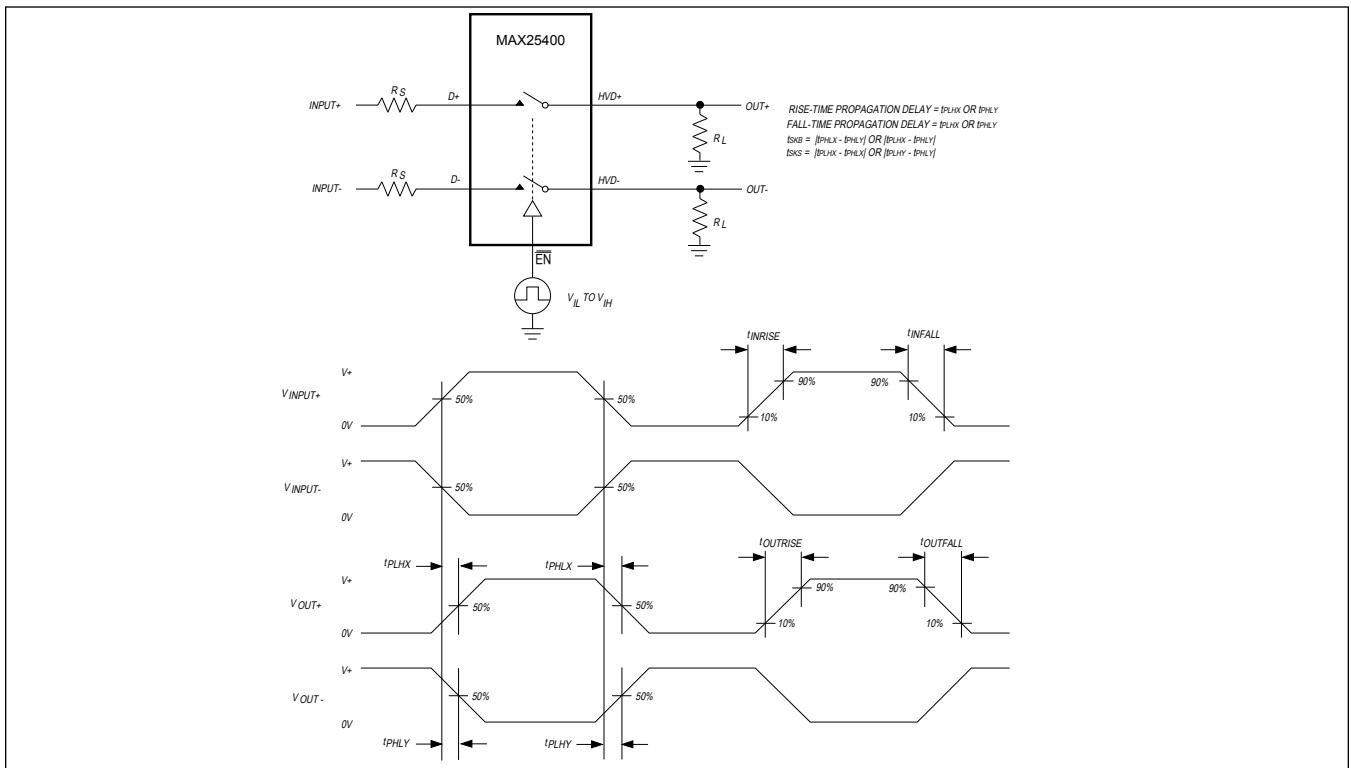
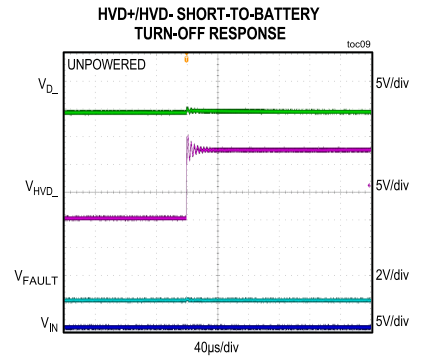
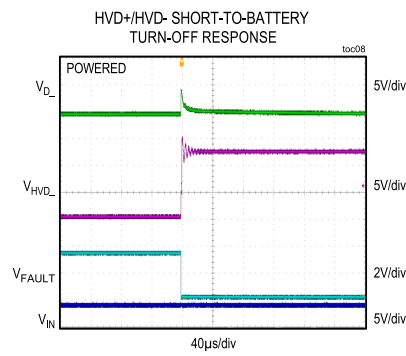
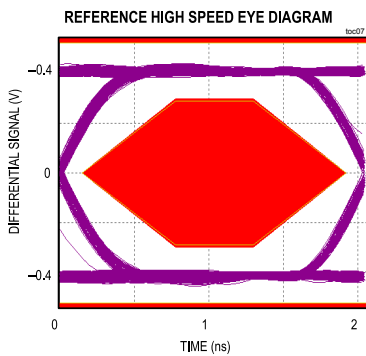
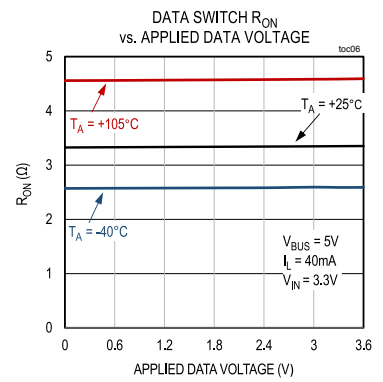
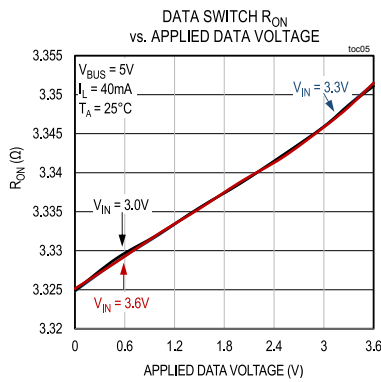
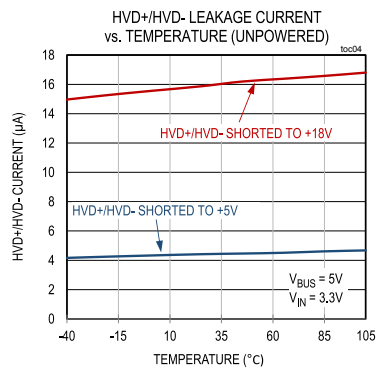
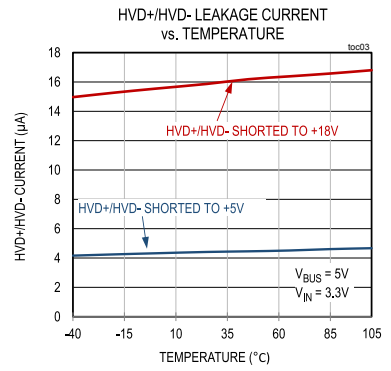
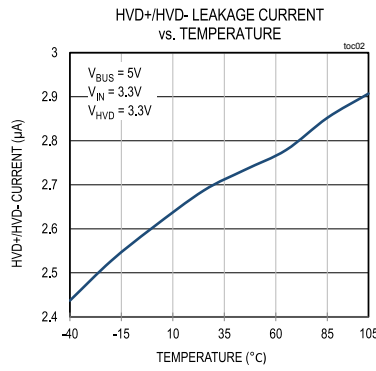
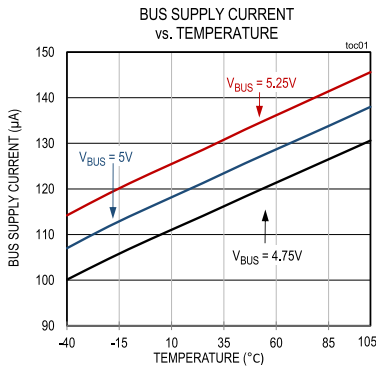

Figure 5. Propagation Delay and Output Skew

Typical Operating Characteristics

($T_A = 25^\circ\text{C}$, unless otherwise noted)



Typical Operating Characteristics (continued)

(T_A = 25°C , unless otherwise noted)

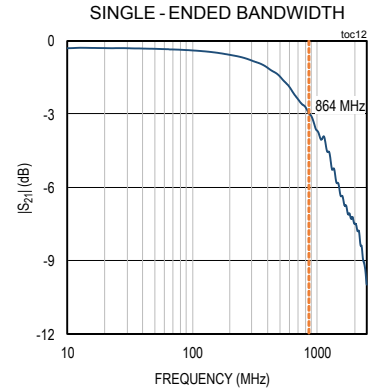
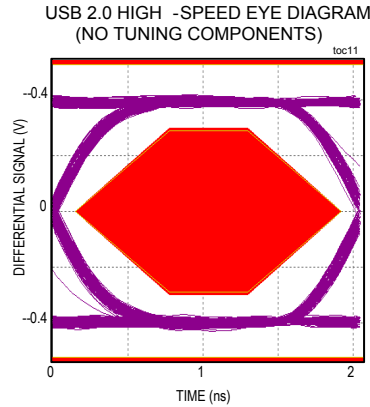
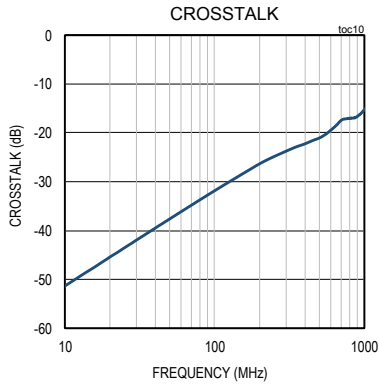

Pin Configuration

MAX25400

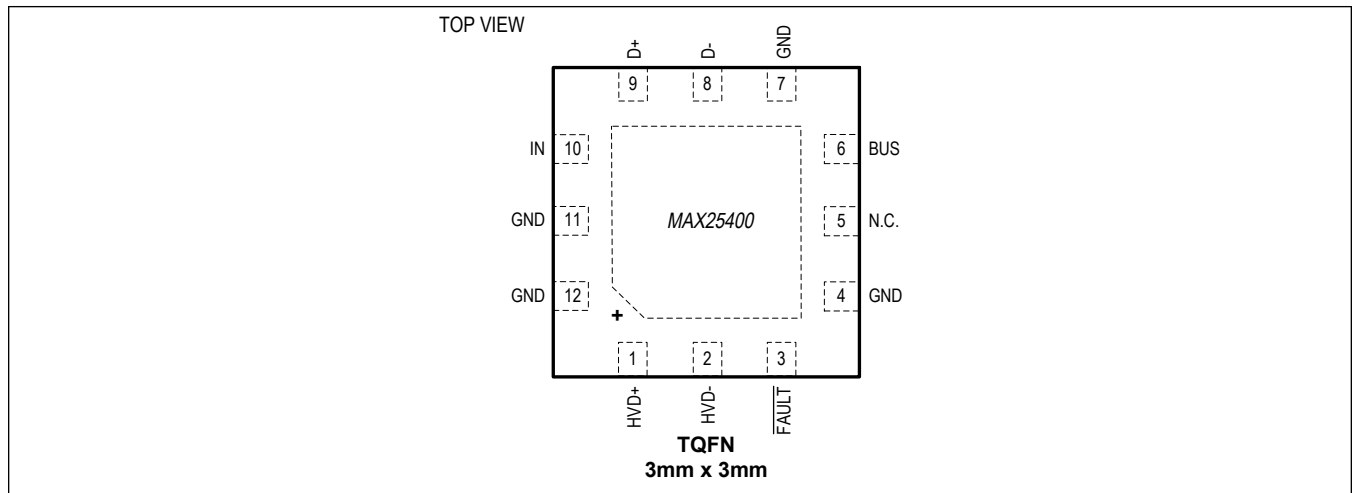

Pin Description

PIN	NAME	FUNCTION
1	HVD+	High-Voltage-Protected USB Differential Data D+ Output. Connect HVD+ directly to USB connector D+.
2	HVD-	High-Voltage-Protected USB Differential Data D- Output. Connect HVD- directly to USB connector D-.
3	FAULT	Open-Drain Fault Condition Indicator Output.
5	N.C.	No Connection. Internally connected to IC ground.
6	BUS	Main IC Supply. Connect BUS to USB +5V supply. Connect a 1μF, low-ESR ceramic capacitor from BUS to GND.

Pin Description (continued)

PIN	NAME	FUNCTION
8	D-	USB Differential Data D- Input. Connect D- to low-voltage USB transceiver D-.
9	D+	USB Differential Data D+ Input. Connect D+ to low-voltage USB transceiver D+.
10	IN	Logic Power-Supply Input. The supply voltage range is from +3.0V to +3.6V. Bypass IN to GND with a 10 μ F ceramic capacitor.
4, 7, 11, 12	GND	Ground

Detailed Description

The MAX25400 device provides high-ESD and short-circuit protection for the USB data in automotive radio, navigation, connectivity, and USB hub applications. The device supports USB Hi-Speed (480Mbps), USB full-speed (12Mbps), and USB low-speed (1.5Mbps) operation.

The short-circuit protection features include short-to-BUS and short-to-battery on the protected HVD+ and HVD-.

The device features high-ESD protection to $\pm 25\text{kV}$ Air Gap Discharge and $\pm 8\text{kV}$ Contact Discharge on all protected HVD+ and HVD- outputs.

The device features two low on-resistance (R_{ON}), USB 2.0 switches.

BUS Undervoltage Lockout (Power-On Reset)

The device has a 4.2V (typ) undervoltage-lockout threshold (V_{UVLO}). When V_{BUS} is less than V_{UVLO} , $\overline{\text{FAULT}}$ is enabled and all the device switches are high impedance.

HVD+ and HVD- Overvoltage Protection

The device has a 3.9V (max) overvoltage threshold (V_{OV_D}). When HVD+ or HVD- is greater than V_{OV_D} , $\overline{\text{FAULT}}$ asserts low and all the device switches are high impedance. Note that HVD+ and HVD- do not have short-to-ground protection. Forward current is limited by the upstream transceiver.

$\overline{\text{FAULT}}$ Output

$\overline{\text{FAULT}}$ goes low when a fault is detected on HVD+, HVD-. $\overline{\text{FAULT}}$ indicates if any of the following conditions exist: overvoltage on HVD-, HVD+; UVLO on V_{BUS} ; or overtemperature. Connect a 100k Ω pullup resistor from $\overline{\text{FAULT}}$ to IN.

Applications Information

Power-Supply Bypass Capacitor

Connect a 1 μ F low-ESR ceramic capacitor from BUS to GND. Connect a 10 μ F ceramic capacitor from IN to GND. Place these components on the same plane as the IC, close to the IN and GND pins.

Layout of USB Data Line Traces

USB Hi-Speed requires careful PCB layout with 90 Ω controlled-impedance matched traces of equal lengths. Use LC tuning components on the data lines, as shown in the [Typical Operating Circuit](#). The values of these components are layout and captive-cable dependent. Contact Maxim technical support for more detailed information.

± 25 kV ESD Protection

As with all Maxim devices, ESD-protection structures are incorporated on all pins to protect against electrostatic discharges encountered during handling and assembly. The device has extra protection against static electricity. Maxim's engineers have developed state-of-the-art structures to protect against ESD of ± 25 kV at the HVD+, HVD- ports without damage. The ESD structures withstand high ESD in all states: normal operation, shutdown, and powered down. After an ESD event, the device keeps working without latchup, whereas other solutions can latch and must be powered down to remove latchup. ESD protection can be tested in various ways; this product is characterized for protection to the following limits:

- ± 2 kV using the Human Body Model
- ± 25 kV using IEC 61000-4-2's Air-Gap Discharge method
- ± 8 kV using the Contact Discharge method specified in IEC 61000-4-2

ESD Test Conditions

ESD performance depends on a variety of conditions. Contact Maxim for a reliability report that documents test setup, test methodology, and test results.

Human Body Model

Figure 6 shows the Human Body Model, and Figure 7 shows the current waveform it generates when discharged into a low impedance. This model consists of a 100pF capacitor charged to the ESD voltage of interest, which is then discharged into the device through a 1.5k Ω resistor.

IEC 61000-4-2

The IEC 61000-4-2 standard covers ESD testing and performance of finished equipment. The MAX25400 helps users design equipment that meets Level 4 of IEC 61000-4-2. The main difference between tests done using the Human Body Model and IEC 61000-4-2 is higher peak current in IEC 61000-4-2. Because series resistance is lower in the IEC 61000-4-2 ESD test model (Figure 8), the ESD withstand voltage measured to this standard is generally lower than that measured using the Human Body Model. Figure 9 shows the current waveform for the ± 8 kV, IEC 61000-4-2 Level 4, ESD Contact Discharge test. The Air-Gap Discharge test involves approaching the device with a charged probe. The Contact Discharge method connects the probe to the device before the probe is energized.

Human Body Test Model

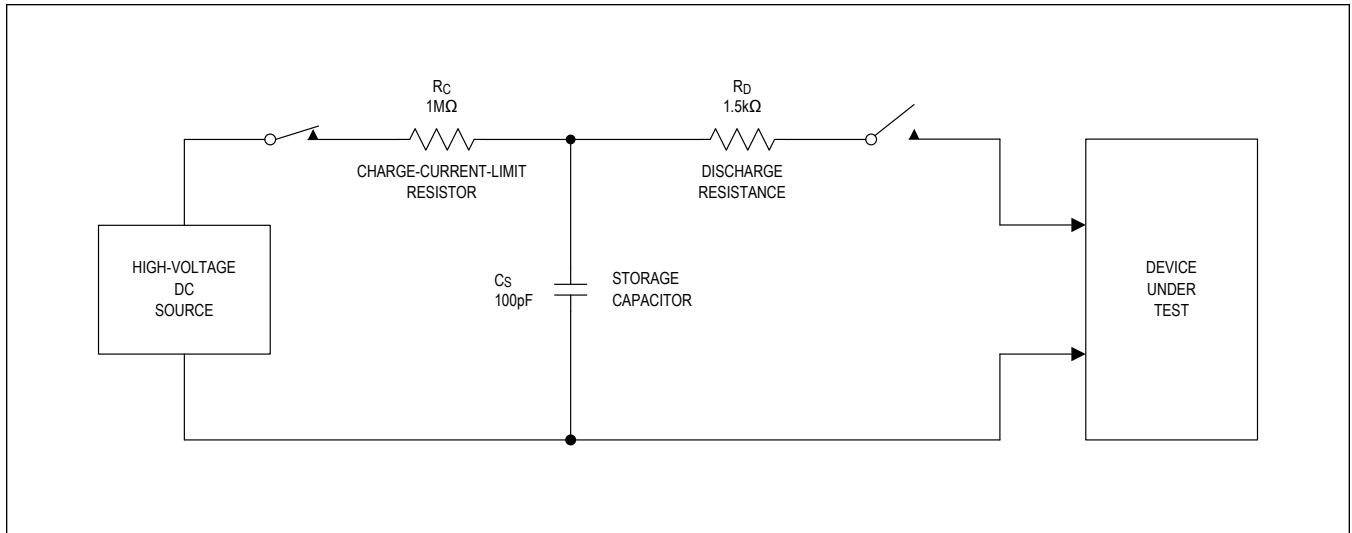

Figure 6. Human Body ESD Test Model

Human Body Current Waveform

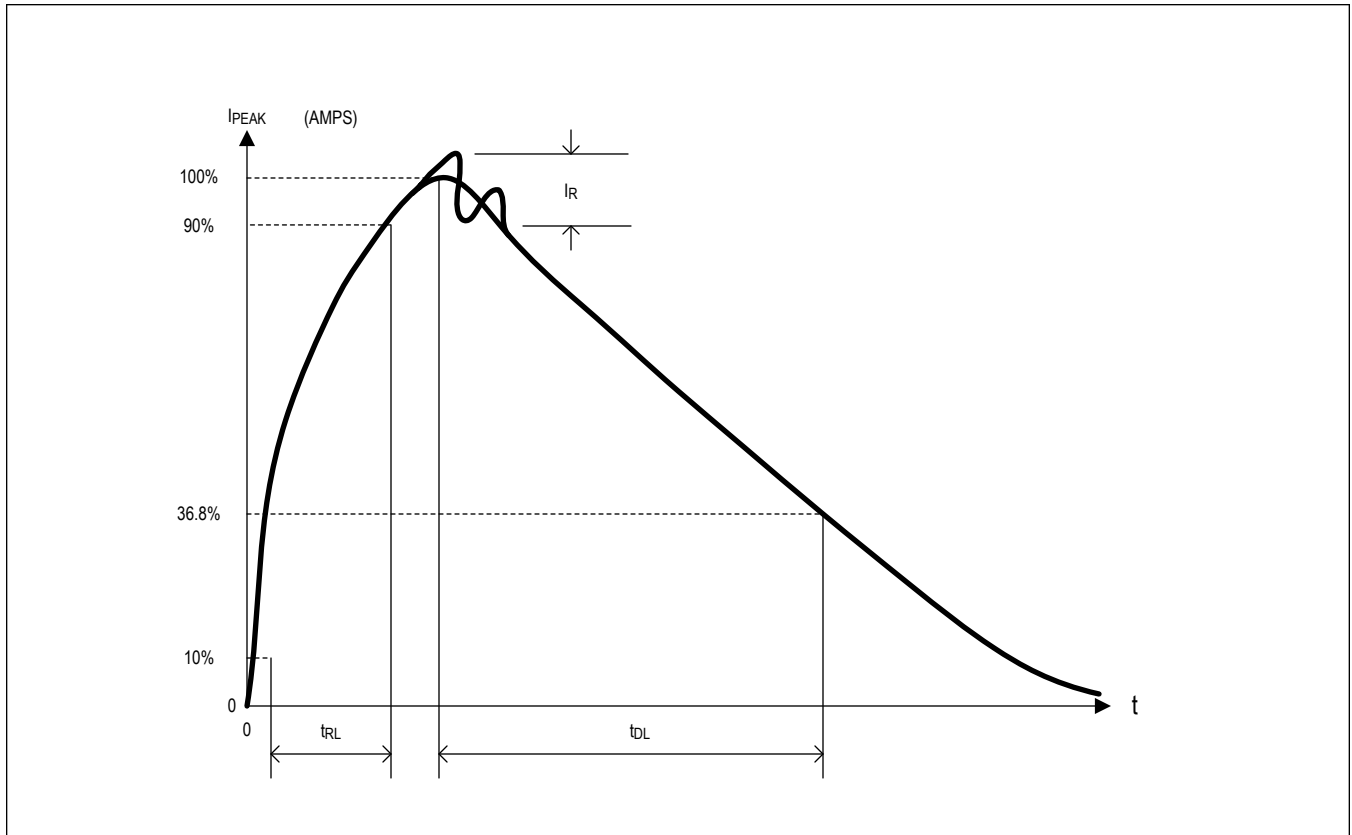

Figure 7. Human Body Current Waveform

IEC 61000-4-2 ESD Test Model

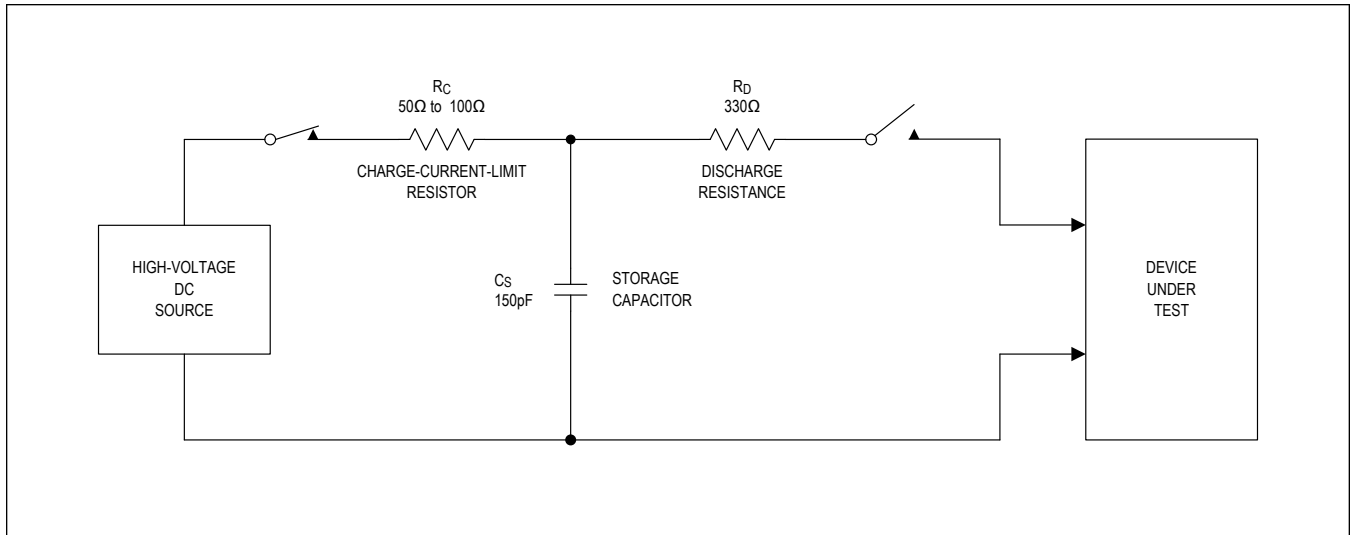

Figure 8. IEC 61000-4-2 ESD Test Model

IEC 61000-4-2 ESD Generator Current Waveform

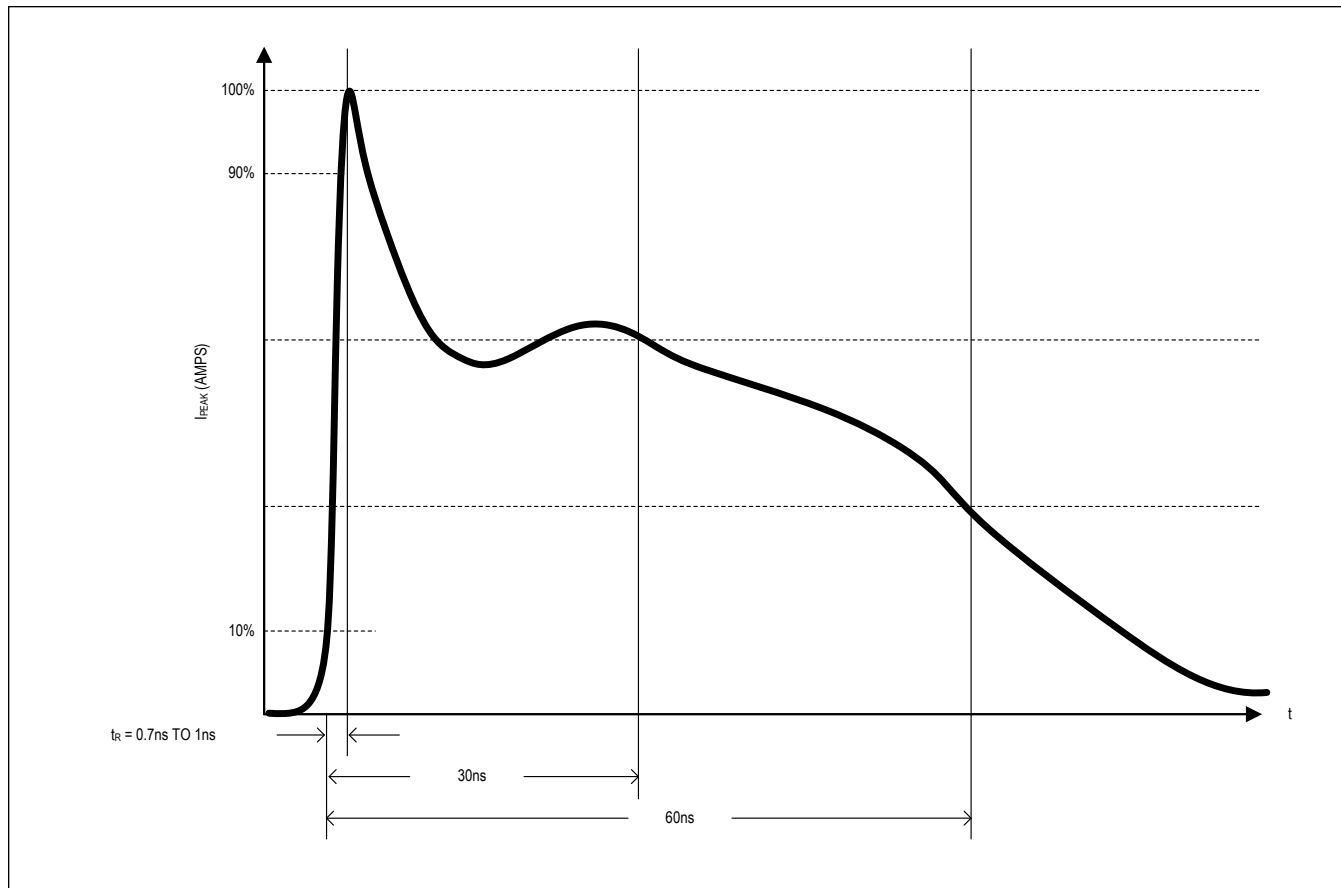

Figure 9. IEC 61000-4-2 ESD Generator Current Waveform

Functional Diagram

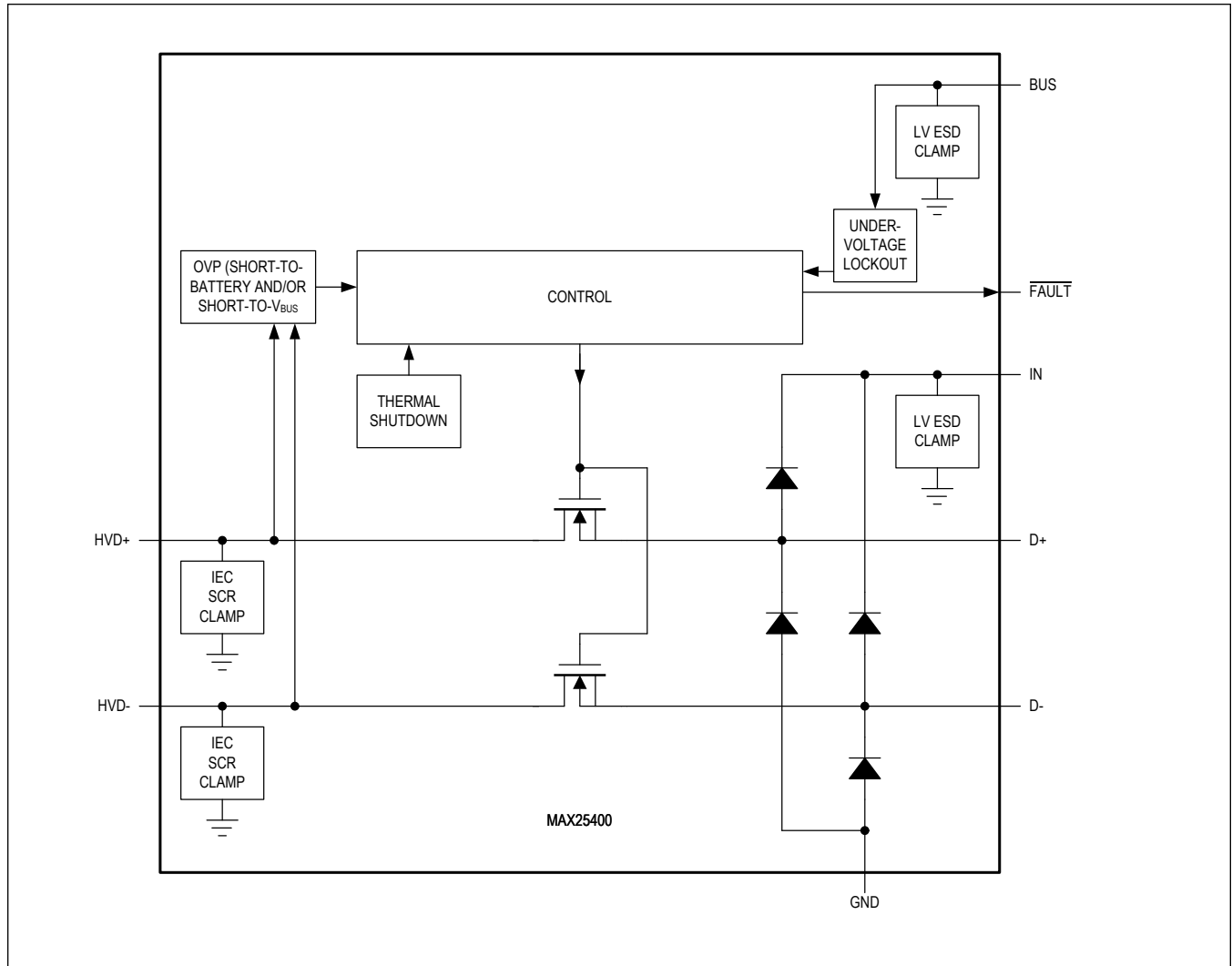

Figure 10. Functional Diagram

Ordering Information

PART NUMBER	TEMPERATURE RANGE	PIN-PACKAGE
MAX25400GTC/V+	-40°C TO +105°C	12 TQFN-EP*

V denotes an automotive qualified part.

+Denotes a lead(Pb)-free/RoHS-compliant package.

*EP = Exposed pad.

Revision History

REVISION NUMBER	REVISION DATE	DESCRIPTION	PAGES CHANGED
0	4/20	Initial release	—
1	8/20	Updated <i>Typical Operating Circuit, Package Information, Electrical Characteristics, Pin Description, Detailed Description, and Applications Information</i>	1, 4–7, 9, 10–17

For pricing, delivery, and ordering information, please visit Maxim Integrated's online storefront at <https://www.maximintegrated.com/en/storefront/storefront.html>.

Maxim Integrated cannot assume responsibility for use of any circuitry other than circuitry entirely embodied in a Maxim Integrated product. No circuit patent licenses are implied. Maxim Integrated reserves the right to change the circuitry and specifications without notice at any time. The parametric values (min and max limits) shown in the Electrical Characteristics table are guaranteed. Other parametric values quoted in this data sheet are provided for guidance.

Looking for pricing, stock, or lifecycle information?

Click below to explore more details on WIN SOURCE:

 [View MAX25400GTC/V+ on WIN SOURCE](#)

 [Maxim Integrated](#) Information

Optimize Your Supply Chain with WIN SOURCE Solutions

-  Global Sourcing Solution
-  Obsolete Management
-  Cost Control Management
-  Shortage Management
-  Alternative Solution
-  Excess Inventory Management