



**THE DATASHEET OF
AT24CS64-XHM-T**





Atmel CS and MAC Series Serial EEPROMs

Value Added Serial EEPROMs with Pre-Programmed
128-bit Serial Numbers and MAC Addresses

AT24CS Series Serial EEPROM

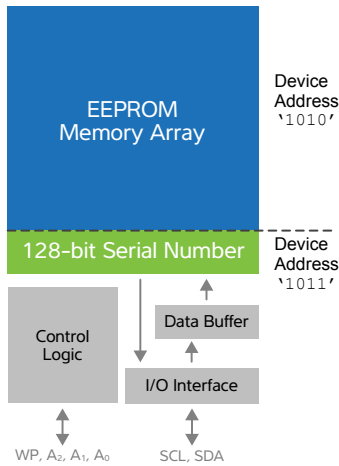

Almost every application in production today can benefit from or already requires a unique identifier or serial number. This number allows identification and tracking for multiple purposes including node identity, build control, version control, customer tracking and authenticity check. Building and maintaining an infrastructure to assign and maintain the serialization of products, particularly in high-volume production lines across multiple locations, can be challenging.

The Atmel® AT24CS series of devices helps resolve this problem by including a unique, factory-programmed, read-only 128-bit Serial Number that can help customers simplify inventory control of mass production lines and enhance product traceability. The CS family comes in multiple EEPROM array densities from 1Kb through 64Kb.

As an application's needs grow over time and greater memory densities are required, the 128-bit Serial Number contained within any CS series Serial EEPROM product remains unique, enabling the value to remain distinctive across the entire portfolio of customer applications.

The AT24CS series maintains all of the features that make serial EEPROMs a must-have element in most designs, including 1 million cycle write endurance, 100-year data retention, byte write capability, and very low active and standby current consumption.

Feature	Benefit
Pre-programmed 128-bit Serial Number	Enhanced product traceability
Serial Number is read-only	Impossible to alter or change the Serial Number
Serial Number is stored in a separate memory area	Does not reduce the user portion of memory array
Serial Number is accessed via a separate device address	Product acts as two separate devices on the bus
Serial Number is unique across all products regardless of density or family	Number uniqueness across all customer platforms or applications where the CS series product is used

Packages Available for CS and MAC Series Serial EEPROMs

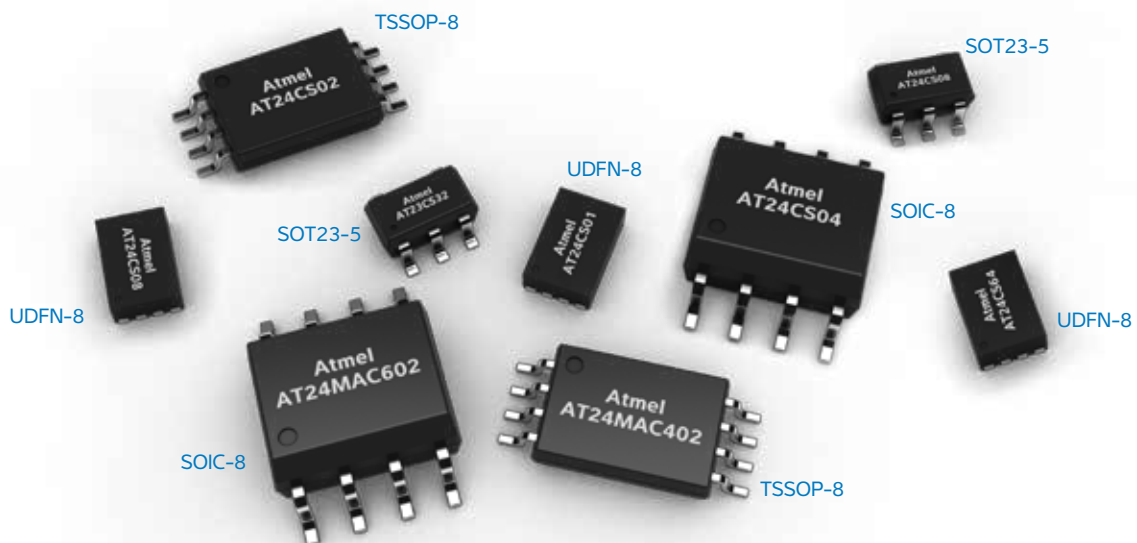

Atmel CS and MAC Series Serial EEPROMs

Value Added Serial EEPROMs with Pre-Programmed 128-bit Serial Numbers and MAC Addresses

AT24MAC Series Serial EEPROM

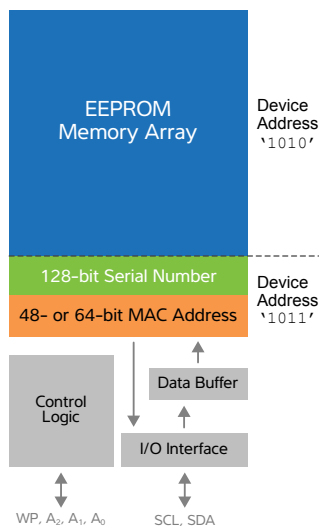

The Internet of Things is rapidly turning products that traditionally have been stand-alone devices into smart products that are accessible via the Internet or can interact with other similar devices on a local network. In order to successfully operate on the network, each device needs a unique identifying number which is commonly referred to as a MAC address.

Acquiring and maintaining a database of MAC addresses, however, can be very cumbersome. The Atmel AT24MAC family alleviates this burden by providing a pre-programmed MAC address inside of a Serial EEPROM device, without consuming any user memory area. By utilizing the new AT24MAC devices with globally unique hardware addresses embedded onboard, designers no longer need to absorb the management costs and time associated with acquiring, using and managing an allotment of MAC/EUI addresses. The AT24MAC series makes it simpler, faster and less expensive to develop Internet-connected products.

By being based upon Atmel's proven and robust Serial EEPROM technology, the AT24MAC series of products provide the same high levels of endurance and data retention that customers have come to expect from Atmel. The products also maintain byte-write capability and low power consumption so that customers need not sacrifice features and performance when choosing to add the MAC address functionality to their design.

Feature	Benefit
Unique pre-programmed MAC/EUI address	No need to manage a database of MAC/EUI addresses
Permanent and reversible EEPROM write protection	Ability to store and protect other system-vital information like lot number, revision, manufacturing location, etc.
Pre-programmed MAC/EUI address does not consume any of the user EEPROM area	Entire EEPROM array is available for use
Pre-programmed, true EUI-64 addresses available	True EUI-64 address available instead of converting a 48-bit value for use in a 64-bit system
Pre-programmed, read-only 128-bit Serial Number	Enhanced product traceability Unique serial number across all Atmel MAC and CS series devices

Application Examples for CS and MAC Series Serial EEPROMs

Industrial



Smart Meters



Security Products



White Goods



Smoke Detectors

Consumer



Printers



Wireless Routers



Mobile Internet Devices



Blood Glucose Meters

Product Availability and Ordering Information

	Atmel Ordering Code	Voltage Range	User EEPROM Density	MAC Address Included	Pre-Programmed Serial Number	Package	Availability
MAC Series Devices	AT24MAC402-SSHM-T	1.7V – 5.5V	2Kb	MAC/EUI-48	128-bit	SOIC 8	Now
	AT24MAC402-XHM-T	1.7V – 5.5V	2Kb	MAC/EUI-48	128-bit	TSSOP 8	Now
	AT24MAC402-MAHM-T	1.7V – 5.5V	2Kb	MAC/EUI-48	128-bit	UDFN 8	Now
	AT24MAC402-STUM-T	1.7V – 5.5V	2Kb	MAC/EUI-48	128-bit	SOT23 5	Now
	AT24MAC602-SSHM-T	1.7V – 5.5V	2Kb	EUI-64	128-bit	SOIC 8	Now
	AT24MAC602-XSHM-T	1.7V – 5.5V	2Kb	EUI-64	128-bit	TSSOP 8	Now
	AT24MAC602-MAHM-T	1.7V – 5.5V	2Kb	EUI-64	128-bit	UDFN 8	Now
	AT24MAC602-STUM-T	1.7V – 5.5V	2Kb	EUI-64	128-bit	SOT23 5	Now
CS Series Devices	AT24CS01-SSHM-T	1.7V – 5.5V	1Kb	none	128-bit	SOIC 8	Now
	AT24CS01-XHM-T	1.7V – 5.5V	1Kb	none	128-bit	TSSOP 8	Now
	AT24CS01-MAHM-T	1.7V – 5.5V	1Kb	none	128-bit	UDFN 8	Now
	AT24CS01-STUM-T	1.7V – 5.5V	1Kb	none	128-bit	SOT23 5	Now
	AT24CS02-SSHM-T	1.7V – 5.5V	2Kb	none	128-bit	SOIC 8	Now
	AT24CS02-XHM-T	1.7V – 5.5V	2Kb	none	128-bit	TSSOP 8	Now
	AT24CS02-MAHM-T	1.7V – 5.5V	2Kb	none	128-bit	UDFN 8	Now
	AT24CS02-STUM-T	1.7V – 5.5V	2Kb	none	128-bit	SOT23 5	Now
	AT24CS04-SSHM-T	1.7V – 5.5V	4Kb	none	128-bit	SOIC 8	Now
	AT24CS04-XHM-T	1.7V – 5.5V	4Kb	none	128-bit	TSSOP 8	Now
	AT24CS04-MAHM-T	1.7V – 5.5V	4Kb	none	128-bit	UDFN 8	Now
	AT24CS04-STUM-T	1.7V – 5.5V	4Kb	none	128-bit	SOT23 5	Now
	AT24CS08-SSHM-T	1.7V – 5.5V	8Kb	none	128-bit	SOIC 8	Now
	AT24CS08-XHM-T	1.7V – 5.5V	8Kb	none	128-bit	TSSOP 8	Now
	AT24CS08-MAHM-T	1.7V – 5.5V	8Kb	none	128-bit	UDFN 8	Now
	AT24CS08-STUM-T	1.7V – 5.5V	8Kb	none	128-bit	SOT23 5	Now
	AT24CS16-SSHM-T	1.7V – 5.5V	8Kb	none	128-bit	SOIC 8	Q2-2013
	AT24CS16-XHM-T	1.7V – 5.5V	16Kb	none	128-bit	TSSOP 8	Q2-2013
	AT24CS16-MAHM-T	1.7V – 5.5V	16Kb	none	128-bit	UDFN 8	Q2-2013
	AT24CS16-STUM-T	1.7V – 5.5V	16Kb	none	128-bit	SOT23 5	Q2-2013
	AT24CS32-SSHM-T	1.7V – 5.5V	32Kb	none	128-bit	SOIC 8	Q2-2013
	AT24CS32-XHM-T	1.7V – 5.5V	32Kb	none	128-bit	TSSOP 8	Q2-2013
	AT24CS32-MAHM-T	1.7V – 5.5V	32Kb	none	128-bit	UDFN 8	Q2-2013
	AT24CS32-STUM-T	1.7V – 5.5V	32Kb	none	128-bit	SOT23 5	Q2-2013
AT24CS64-SSHM-T	1.7V – 5.5V	64Kb	none	128-bit	SOIC 8	Q2-2013	
AT24CS64-XHM-T	1.7V – 5.5V	64Kb	none	128-bit	TSSOP 8	Q2-2013	
AT24CS64-MAHM-T	1.7V – 5.5V	64Kb	none	128-bit	UDFN 8	Q2-2013	
AT24CS64-STUM-T	1.7V – 5.5V	64Kb	none	128-bit	SOT23 5	Q2-2013	

Atmel MAC/Serial Number Products
Home Page



Atmel Serial EEPROM Products
Home Page



Atmel Memory Products
Home Page



Atmel | Enabling Unlimited Possibilities®

Atmel Corporation 1600 Technology Drive, San Jose, CA 95110 USA T: (+1)(408) 441.0311 F: (+1)(408) 436.4200 | www.atmel.com



© 2013 Atmel Corporation. All rights reserved. / Rev: Atmel-8861A-MAC-CS_E_A4_0213

Atmel®, Atmel logo and combinations thereof, and others are registered trademarks or trademarks of Atmel Corporation or its subsidiaries. Other terms and product names may be trademarks of others.

Disclaimer: The information in this document is provided in connection with Atmel products. No license, express or implied, by estoppel or otherwise, to any intellectual property right is granted by this document or in connection with the sale of Atmel products. EXCEPT AS SET FORTH IN THE ATMEL TERMS AND CONDITIONS OF SALES LOCATED ON THE ATMEL WEBSITE, ATMEL ASSUMES NO LIABILITY WHATSOEVER AND DISCLAIMS ANY EXPRESS, IMPLIED OR STATUTORY WARRANTY RELATING TO ITS PRODUCTS INCLUDING, BUT NOT LIMITED TO, THE IMPLIED WARRANTY OF MERCHANTABILITY, FITNESS FOR A PARTICULAR PURPOSE, OR NON-INFRINGEMENT. IN NO EVENT SHALL ATMEL BE LIABLE FOR ANY DIRECT, INDIRECT, CONSEQUENTIAL, PUNITIVE, SPECIAL OR INCIDENTAL DAMAGES (INCLUDING, WITHOUT LIMITATION, DAMAGES FOR LOSS AND PROFITS, BUSINESS INTERRUPTION, OR LOSS OF INFORMATION) ARISING OUT OF THE USE OR INABILITY TO USE THIS DOCUMENT, EVEN IF ATMEL HAS BEEN ADVISED OF THE POSSIBILITY OF SUCH DAMAGES. Atmel makes no representations or warranties with respect to the accuracy or completeness of the contents of this document and reserves the right to make changes to specifications and products descriptions at any time without notice. Atmel does not make any commitment to update the information contained herein. Unless specifically provided otherwise, Atmel products are not suitable for, and shall not be used in, automotive applications. Atmel products are not intended, authorized, or warranted for use as components in applications intended to support or sustain life.

Looking for pricing, stock, or lifecycle information?

Click below to explore more details on WIN SOURCE:

-  [View AT24CS64-XHM-T on WIN SOURCE](#)
-  [Microchip Technology](#) Information

Optimize Your Supply Chain with WIN SOURCE Solutions

-  Global Sourcing Solution
-  Obsolete Management
-  Cost Control Management
-  Shortage Management
-  Alternative Solution
-  Excess Inventory Management