



# THE DATASHEET OF D3SH-A0R



# D3SH

Surface Mount Switch

## The smallest detection switch in the world. Ideal for miniature mobile devices

(OMRON's data as of September 2007)

- Ultra small size and ultra low profile contributing to down-sizing of sets devices. (3.0 × 3.4 × 0.9 mm (W × D × H))
- A unique mechanism enables high contact reliability and high precision operation.
- Horizontal 2-way detection and long stroke for easy installation are available.
- Meet a variety of applications by contact and lever variations

RoHS Compliant

### Model Number Legend

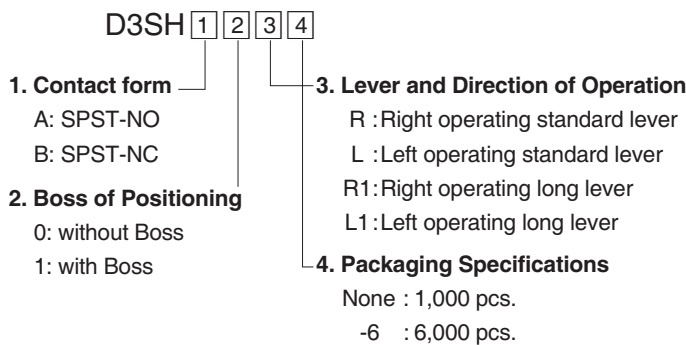

### Contact Form

#### ●SPST-NO

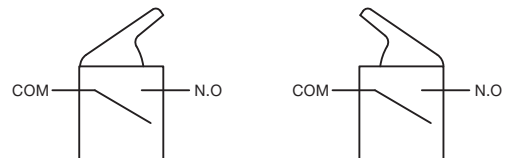

#### ●SPST-NC

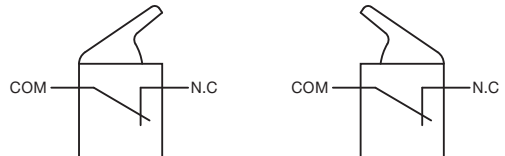

Note: The cover has the same electric potential as the COM terminal.

### List of Models

#### ●Standard Lever Models

Contact form	Direction of Operation	Boss of Positioning	Model	Packing form*
SPST-NO	Right	With Boss	D3SH-A1R	1,000 pcs.
			D3SH-A1R-6	6,000 pcs.
		Without Boss	D3SH-A0R	1,000 pcs.
	D3SH-A0R-6		6,000 pcs.	
	Left	With Boss	D3SH-A1L	1,000 pcs.
			D3SH-A1L-6	6,000 pcs.
Without Boss		D3SH-A0L	1,000 pcs.	
	D3SH-A0L-6	6,000 pcs.		
SPST-NC	Right	With Boss	D3SH-B1R	1,000 pcs.
			D3SH-B1R-6	6,000 pcs.
		Without Boss	D3SH-B0R	1,000 pcs.
	D3SH-B0R-6		6,000 pcs.	
	Left	With Boss	D3SH-B1L	1,000 pcs.
			D3SH-B1L-6	6,000 pcs.
Without Boss		D3SH-B0L	1,000 pcs.	
	D3SH-B0L-6	6,000 pcs.		

\* Products are packed with embossed tape.

#### ●Long Lever Models

Contact form	Direction of Operation	Boss of Positioning	Model	Packing form*
SPST-NO	Right	With Boss	D3SH-A1R1	1,000 pcs.
			D3SH-A1R1-6	6,000 pcs.
		Without Boss	D3SH-A0R1	1,000 pcs.
	D3SH-A0R1-6		6,000 pcs.	
	Left	With Boss	D3SH-A1L1	1,000 pcs.
			D3SH-A1L1-6	6,000 pcs.
Without Boss		D3SH-A0L1	1,000 pcs.	
	D3SH-A0L1-6	6,000 pcs.		
SPST-NC	Right	With Boss	D3SH-B1R1	1,000 pcs.
			D3SH-B1R1-6	6,000 pcs.
		Without Boss	D3SH-B0R1	1,000 pcs.
	D3SH-B0R1-6		6,000 pcs.	
	Left	With Boss	D3SH-B1L1	1,000 pcs.
			D3SH-B1L1-6	6,000 pcs.
Without Boss		D3SH-B0L1	1,000 pcs.	
	D3SH-B0L1-6	6,000 pcs.		

\* Products are packed with embossed tape.

### Contact Specifications

Contact Specifications	Slide
Minimum applicable load	15 μA at 3 VDC

### Ratings

Rated voltage	Resistive load
5 VDC	1 mA

Note. The ratings values apply under the following test conditions:

- (1) Ambient temperature: 20±2°C
- (2) Ambient humidity: 65±5%
- (3) Operating frequency: 20 operations/min

## Characteristics

Permissible operating speed		1 mm to 300 mm/s
Permissible operating frequency	Mechanical	60 operations/min
	Electrical	60 operations/min
Insulation resistance		100 MΩ min. (at 100 VDC with insulation tester)
Contact resistance (initial value)		3Ω max.
Dielectric strength	Between terminals of the same polarity	100 VAC (50/60 Hz for 1 min)
Vibration resistance *1	Malfunction	10 to 55 Hz, 1.5 mm double amplitude
Shock resistance	Durability	1000 m/s <sup>2</sup> {approx. 100G} max.
	Malfunction *1	300 m/s <sup>2</sup> {approx. 30G} max.
Durability *2	Mechanical	150,000 operations min. (20 operations/min)
	Electrical	100,000 operations min. (20 operations/min)
Ambient operating temperature		-25 to +85°C (at ambient humidity 60% max.) (with no icing or condensation)
Ambient operating humidity		85% max. (for +5 to +35°C)
Weight		Approx. 0.02 g

Note: The data given above are initial values.

\*1. The given values apply for Total Travel Position. Close or open circuit of the contact is 1ms max.

\*2. For testing conditions, consult your OMRON sales representative.

## Dimensions (Unit: mm) and Operating Characteristics

The □ is replaced with the code for the contact form that you need. See the "List of Models" for available combinations of models.

### Standard Lever Models

Operating Characteristics	Model	D3SH-□□R D3SH-□□L
Operating Force	OF Max.	0.3 N {31 gf}
Free Position	FP	5.4±0.2 mm
Operating Position	OP	5.0±0.2 mm
Total Travel Position	TTP	3.8±0.15 mm

### ●Right operating - without Boss

D3SH-□0R

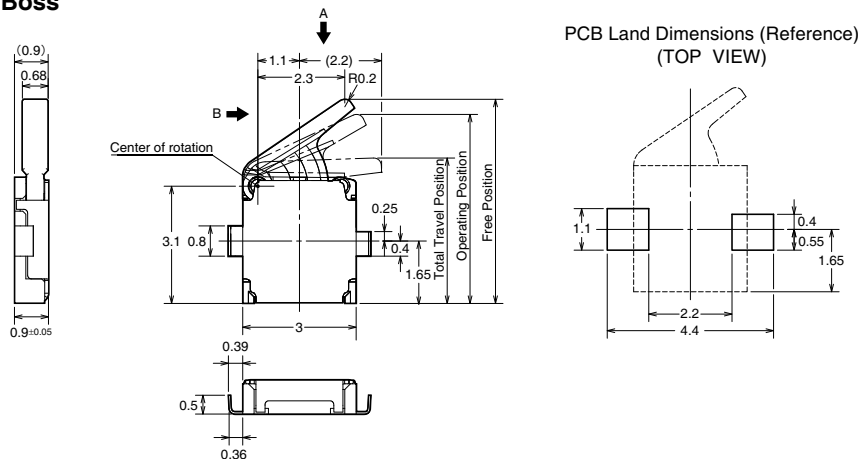

### ●Left operating - without Boss

D3SH-□0L

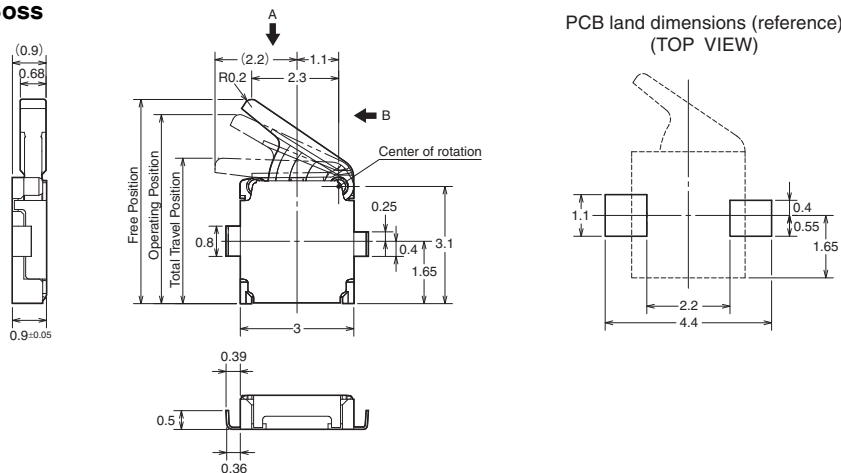

Note 1. Unless otherwise specified, a tolerance of ±0.15 mm applies to all dimensions.

Note 2. The operating characteristics are for operation in the A direction (S) and B direction (I, !) has the same operation characteristic values as of the A direction.

●Right operating - with Boss  
D3SH-□1R

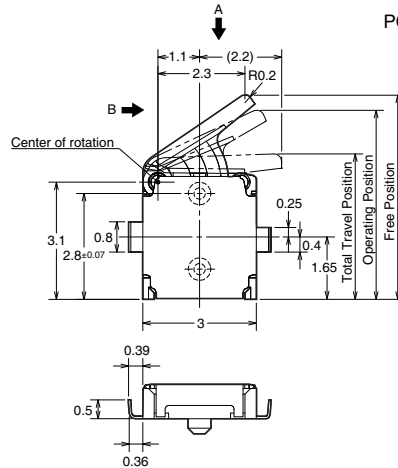
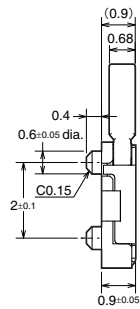

PCB mounting hole and land dimensions (reference)  
(TOP VIEW)

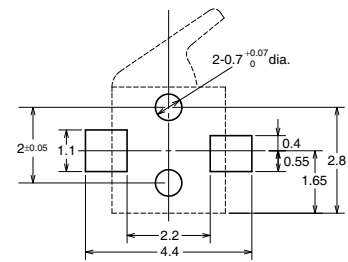

●Left operating - with Boss  
D3SH-□1L

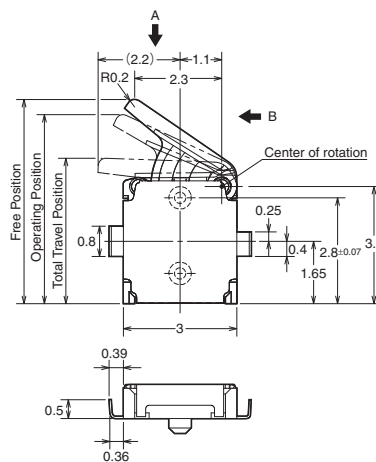
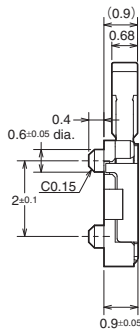

PCB mounting hole and land dimensions (reference)  
(TOP VIEW)

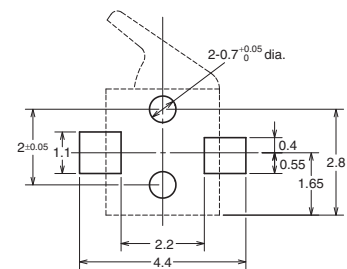

Note 1. Unless otherwise specified, a tolerance of  $\pm 0.15$  mm applies to all dimensions.

Note 2. The operating characteristics are for operation in the A direction (S) and B direction (!) has the same operation characteristic values as of the A direction.

Long Lever Models

Operating Characteristics	Model	D3SH-□□R1 D3SH-□□L1
Operating Force	OF Max.	0.24 N (24 gf)
Free Position	FP	5.9 $\pm$ 0.3 mm
Operating Position	OP	5.4 $\pm$ 0.3 mm
Total Travel Position	TTP	3.8 $\pm$ 0.2 mm

●Right operating - without Boss  
D3SH-□0R1

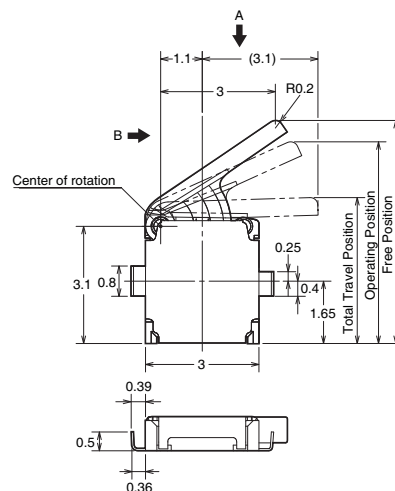
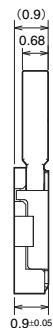

PCB land dimensions (reference)  
(TOP VIEW)

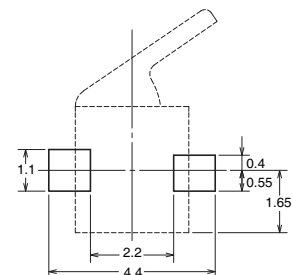

Note 1. Unless otherwise specified, a tolerance of  $\pm 0.15$  mm applies to all dimensions.

Note 2. The operating characteristics are for operation in the A direction (S) and B direction (!) has the same operation characteristic values as of the A direction.

## ●Left operating - without Boss D3SH-□0L1

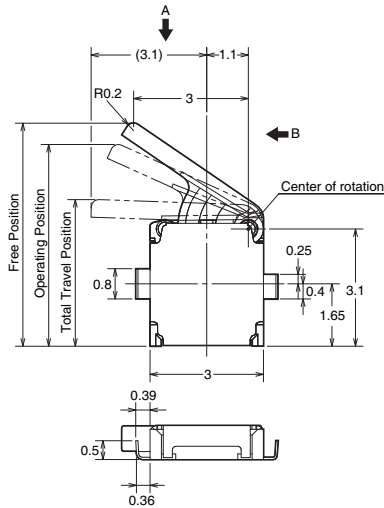
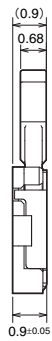

PCB land dimensions (reference)  
(TOP VIEW)

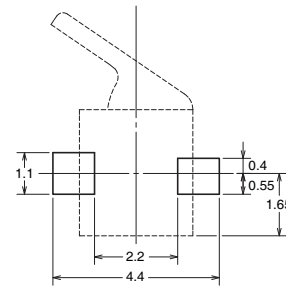

## ●Right operating - with Boss D3SH-□1R1

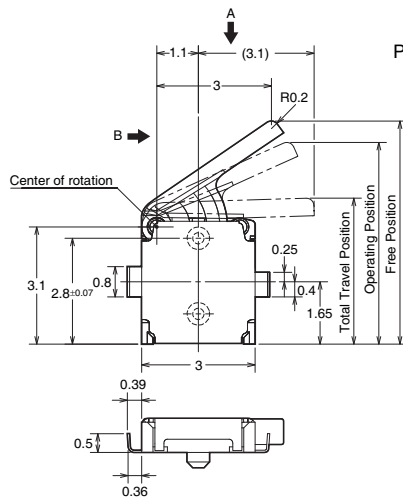
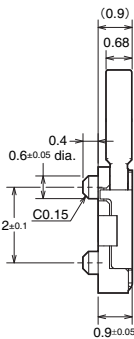

PCB mounting hole and land dimensions (reference)  
(TOP VIEW)

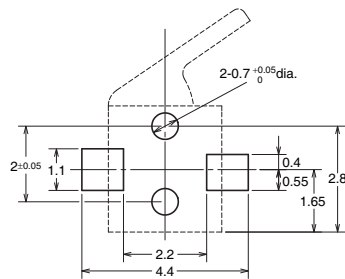

## ●Left operating - with Boss D3SH-□1L1

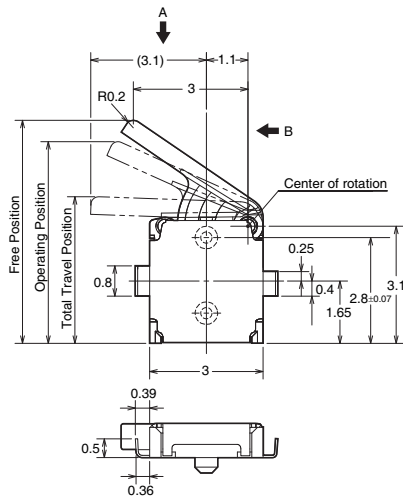
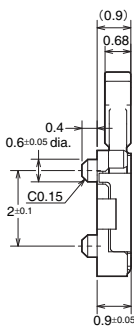

PCB mounting hole and land dimensions (reference)  
(TOP VIEW)

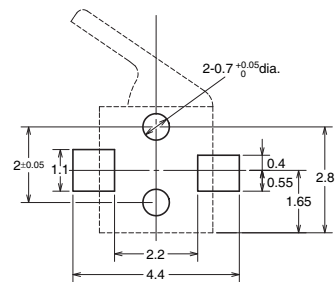

Note 1. Unless otherwise specified, a tolerance of  $\pm 0.15$  mm applies to all dimensions.

Note 2. The operating characteristics are for operation in the A direction (S) and B direction (I, !) has the same operation characteristic values as of the A direction.

## Packaging Specifications

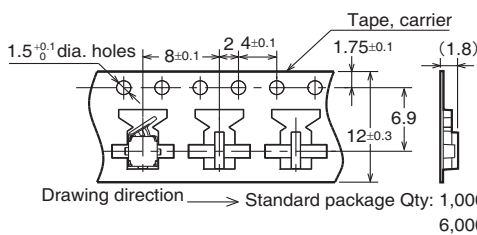

Standard package Qty: 1,000 pcs./reel  
6,000 pcs./reel

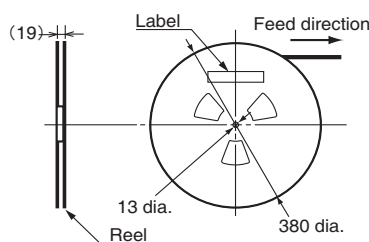

Standards	Conforms to JEITA
Package	Qty 1,000 pcs./reel Qty 6,000 pcs./reel

## Precautions

★Please refer to "Common Precautions" for correct use.

### Caution

#### ●Electrical Ratings

- Confirm the contact load in order to select an appropriate switch rating.
- Do not apply an excessive electrical load to the contacts, otherwise the contacts may weld, resulting in a short circuit or burning.

#### ●Terminal Connection

- Do not use flow soldering or hand soldering to solder terminals.
- Conduct reflow soldering within the range shown in the terminal temperature profile below. Some reflow soldering devices have extremely high peak values. Do a test in advance to confirm proper soldering conditions.
- Do not conduct reflow soldering more than twice. Also provide a time interval of at least five minutes between the first and second reflow soldering processes to allow the Switch to return to room temperature. Heating the Switch continuously (without an interval) may cause the edges of the Switch to melt and degrade the characteristics.
- When printing for a cream solder process, a 0.13 mm screen thickness is recommended.
- Be sure to provide local ventilation.

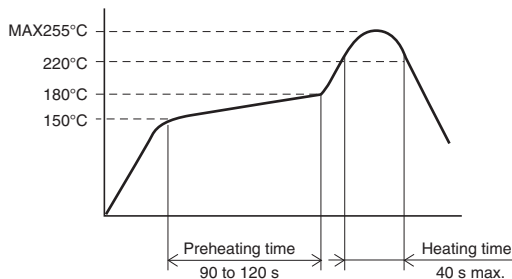

#### ●Printed Circuit Boards

Special attention must be paid to the handling of printed circuit boards after a Switch has been mounted onto them. Airborne PCB particles may penetrate the interior of the Switch when printed circuit boards are separated by cutting. Also, do not stack printed circuit boards that have Switches mounted on them.

#### ●Product Specification Details

- This document provides only a partial list of specifications. It is recommended that you request complete drawings and specifications prior to purchasing or using the product.

### Correct Use

#### ●Mounting

- The cover has the same electric potential as the COM terminal. Do not short-circuit the cover with a NO or NC terminal when mounting the cover.

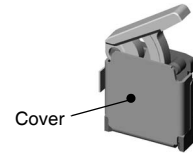

- Be careful of the following points. Incorrect handling may lead to insufficient actuator return, Switch damage, or reduced durability.

- Set the operating body in line with the direction of the actuator movement, and make sure that the operating body is completely separate from the actuator when the Switch is in the free position (FP). When the actuator is operated from the crosswise direction of the Switch, make sure that the corner of the operating body has a minimum radius of R1.

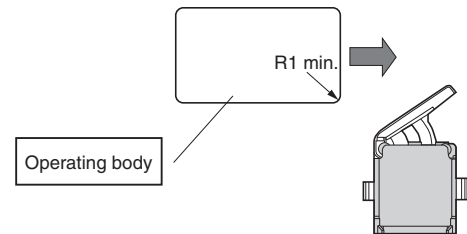

- Set the Switch stroke to 70% to 100% of the overtravel (the difference between the operating position and the total travel position).
- Do not subject the Switch to operations that involve strong impact.
- Do not use the Switch as a stopper.
- Do not apply excessive loads to the cover or operate the actuator from a direction other than a specified operating direction.
- Do not use an adhesive to secure the Switch.

- A lubricant is used in the Switch. Some of the lubricant may seep out because the Switch does not have an airtight construction. Consider this possibility with respect to the usage conditions when designing or using the Switch.

#### ●Application Environment

Do not use the Switch in locations that are subject to toxic gas, silicon, excessive dust, excessive dirt, high temperatures, high humidity, sudden temperature changes, water splashes, or oil splashes.

Otherwise, damage resulting by faulty contact of the Switch contacts, corrosion, or other causes, or other functional faults may occur.

#### ●Insulation and Wiring

Be sure that the installation conditions provide a sufficient insulation distance between Switch terminals and other metal parts, lands, etc.

#### ●Cleaning

The Switch does not have an airtight construction, and it must not be cleaned with cleaning fluids. Malfunctions may occur if the cleaning fluid penetrates the interior of the Switch together with flux or foreign matter from the surface of the PCB.

#### ●Confirmation with Actual Equipment

Be sure to confirm the quality of the product under the load and environmental conditions that will be used during actual applications.

• Application examples provided in this document are for reference only. In actual applications, confirm equipment functions and safety before using the product.  
• Consult your OMRON representative before using the product under conditions which are not described in the manual or applying the product to nuclear control systems, railroad systems, aviation systems, vehicles, combustion systems, medical equipment, amusement machines, safety equipment, and other systems or equipment that may have a serious influence on lives and property if used improperly. Make sure that the ratings and performance characteristics of the product provide a margin of safety for the system or equipment, and be sure to provide the system or equipment with double safety mechanisms.

**Note: Do not use this document to operate the Unit.**

---

**OMRON Corporation**



**ELECTRONIC AND MECHANICAL COMPONENTS COMPANY**

**Contact: [www.omron.com/ecb](http://www.omron.com/ecb)**

**Cat. No.B112-E1-02  
0812(0207)(O)**

## Looking for pricing, stock, or lifecycle information?

Click below to explore more details on WIN SOURCE:

-  [View D3SH-A0R on WIN SOURCE](#)
-  [Omron Information](#)

## Optimize Your Supply Chain with WIN SOURCE Solutions

-  Global Sourcing Solution
-  Obsolete Management
-  Cost Control Management
-  Shortage Management
-  Alternative Solution
-  Excess Inventory Management