

1Mx16 HIGH-SPEED ASYNCHRONOUS CMOS STATIC RAM WITH 3.3V/1.8V SUPPLY

FEATURES

- High-speed access time: 10ns, 12ns
- High- performance, low power CMOS process
- Multiple center power and ground pins for greater noise immunity
- Easy memory expansion with CS# and OE#
- TTL compatible inputs and outputs
- Single power supply
 - 1.65V-2.2V VDD (IS61/64WV102416DALL)
 - 2.4V-3.6V VDD (IS61/64WV102416DBLL)
- Packages available :
 - 48 ball mini BGA (6mm x 8mm)
 - 48 pin TSOP (Type I)
- Industrial and Automotive temperature support
- Lead-free available
- Data Control for upper and lower bytes

DESCRIPTION

The *ISSI* IS61/64WV102416DALL/BLL are high-speed, 16M bit static RAMs organized as 1024K words by 16 bits. It is fabricated using *ISSI*'s high-performance CMOS technology.

This highly reliable process coupled with innovative circuit design techniques, yields high-performance and low power consumption devices.

When CS# is HIGH (deselected), the device assumes a standby mode at which the power dissipation can be reduced down with CMOS input levels. Easy memory expansion is provided by using Chip Enable and Output Enable inputs. The active LOW Write Enable (WE#) controls both writing and reading of the memory.

A data byte allows Upper Byte (UB#) and Lower Byte (LB#) access.

The device is packaged in the JEDEC standard 48-Pin TSOP (TYPE I) and 48-pin mini BGA (6mm x 8mm).

FUNCTIONAL BLOCK DIAGRAM

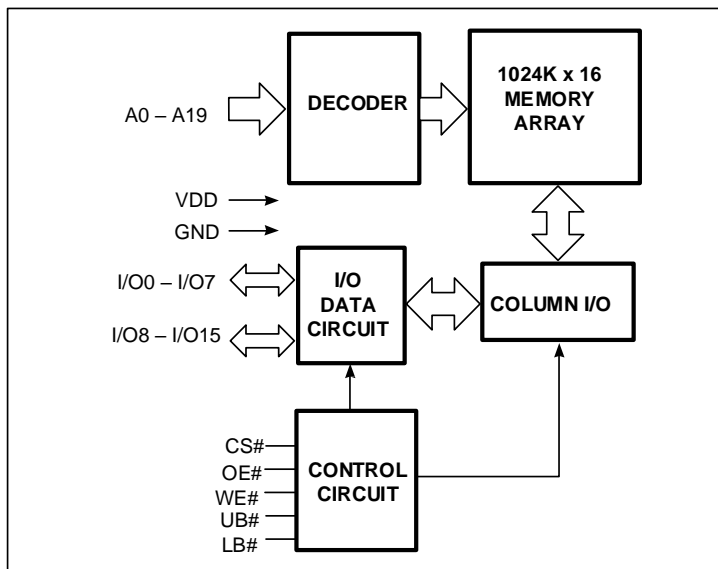

Copyright © 2019 Integrated Silicon Solution, Inc. All rights reserved. ISSI reserves the right to make changes to this specification and its products at any time without notice. ISSI assumes no liability arising out of the application or use of any information, products or services described herein. Customers are advised to obtain the latest version of this device specification before relying on any published information and before placing orders for products.

Integrated Silicon Solution, Inc. does not recommend the use of any of its products in life support applications where the failure or malfunction of the product can reasonably be expected to cause failure of the life support system or to significantly affect its safety or effectiveness. Products are not authorized for use in such applications unless Integrated Silicon Solution, Inc. receives written assurance to its satisfaction, that:

- a.) the risk of injury or damage has been minimized;
- b.) the user assume all such risks; and
- c.) potential liability of Integrated Silicon Solution, Inc is adequately protected under the circumstances

PIN CONFIGURATIONS

48-Pin mini BGA (6mm x 8mm)

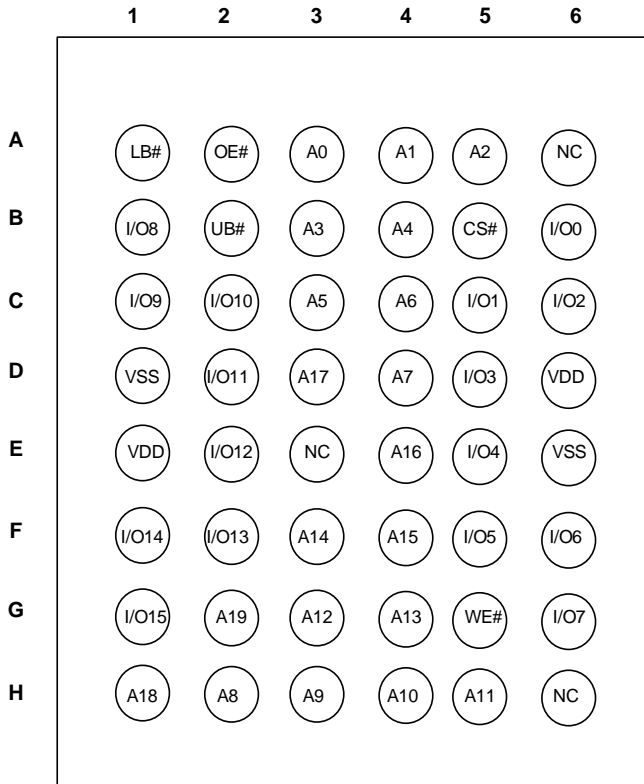

48-Pin TSOP ,TYPE I (12mm x 20mm)

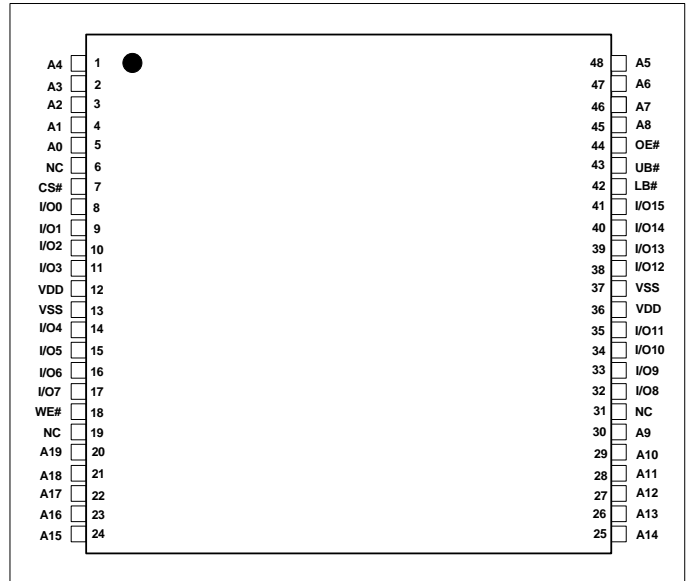

PIN DESCRIPTIONS

A0-A19	Address Inputs
I/O0-I/O15	Data Inputs/Outputs
CS#	Chip Enable Input
OE#	Output Enable Input
WE#	Write Enable Input
LB#	Lower-byte Control (I/O0-I/O7)
UB#	Upper-byte Control (I/O8-I/O15)
NC	No Connection
VDD	Power
VSS	Ground

FUNCTION DESCRIPTION

SRAM is one of random access memories. Each byte or word has an address and can be accessed randomly. SRAM has three different modes supported. Each function is described below with Truth Table.

STANDBY MODE

Device enters standby mode when deselected (CS# HIGH). The input and output pins (I/O0-15) are placed in a high impedance state. CMOS input in this mode will maximize saving power.

WRITE MODE

Write operation issues with Chip selected (CS#) and Write Enable (WE#) input LOW. The input and output pins (I/O0-15) are in data input mode. Output buffers are closed during this time even if OE# is LOW. UB# and LB# enables a byte write feature. By enabling LB# LOW, data from I/O pins (I/O0 through I/O7) are written into the location specified on the address pins. And with UB# being LOW, data from I/O pins (I/O8 through I/O15) are written into the location.

READ MODE

Read operation issues with Chip selected (CS# LOW) and Write Enable (WE#) input HIGH. When OE# is LOW, output buffer turns on to make data output. Any input to I/O pins during READ mode is not permitted. UB# and LB# enables a byte read feature. By enabling LB# LOW, data from memory appears on I/O0-7. And with UB# being LOW, data from memory appears on I/O8-15.

In the READ mode, output buffers can be turned off by pulling OE# HIGH. In this mode, internal device operates as READ but I/Os are in a high impedance state. Since device is in READ mode, active current is used.

POWER UP INITIALIZATION

The device includes on-chip voltage sensor used to launch POWER-UP initialization process.

When VDD reaches stable level, the device requires 150us of tPU (Power-Up Time) to complete its self-initialization process.

When initialization is complete, the device is ready for normal operation.

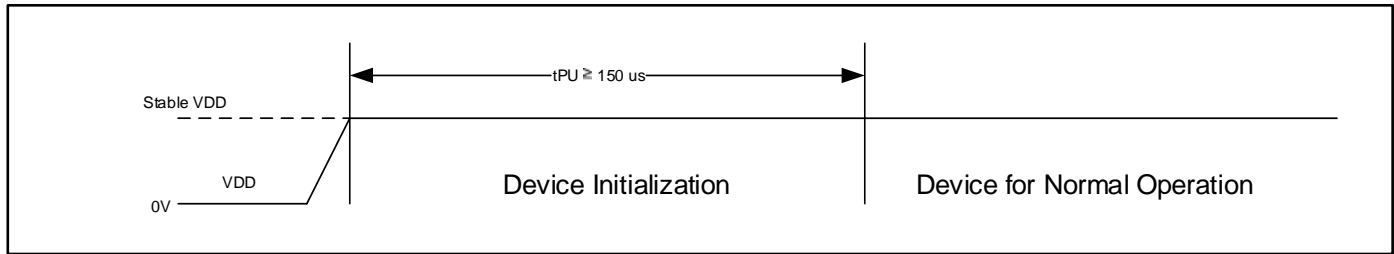

TRUTH TABLE

Mode	CS#	WE#	OE#	LB#	UB#	I/O0-I/O7	I/O8-I/O15	VDD Current
Not Selected	H	X	X	X	X	High-Z	High-Z	ISB1, ISB2
Output Disabled	L	H	H	L	L	High-Z	High-Z	ICC
	L	H	H	H	L	High-Z	High-Z	
Read	L	H	L	L	H	DOUT	High-Z	ICC
	L	H	L	H	L	High-Z	DOUT	
	L	H	L	L	L	DOUT	DOUT	
Write	L	L	X	L	H	DIN	High-Z	ICC
	L	L	X	H	L	High-Z	DIN	
	L	L	X	L	L	DIN	DIN	

ABSOLUTE MAXIMUM RATINGS AND Operating Range

ABSOLUTE MAXIMUM RATINGS (1)

Symbol	Parameter	Value	Unit
Vterm	Terminal Voltage with Respect to VSS	-0.5 to V _{DD} + 0.5V	V
V _{DD}	V _{DD} Related to VSS	-0.3 to 4.0	V
tStg	Storage Temperature	-65 to +150	°C
P _T	Power Dissipation	1.0	W

Notes:

- Stress greater than those listed under ABSOLUTE MAXIMUM RATINGS may cause permanent damage to the device. This is a stress rating only and functional operation of the device at these or any other conditions above those indicated in the operational sections of this specification is not implied. Exposure to absolute maximum rating conditions for extended periods may affect reliability.

PIN CAPACITANCE (1)

Parameter	Symbol	Test Condition	Max	Units
Input capacitance	C _{IN}	T _A = 25°C, f = 1 MHz, V _{DD} = V _{DD} (typ)	6	pF
DQ capacitance (IO0–IO15)	C _{I/O}		8	pF

Note:

- These parameters are guaranteed by design and tested by a sample basis only.

OPERATING RANGE

IS61/64WV102416DALL
IS61/64WV102416DBLL



Range	Ambient Temperature	PART NUMBER	VDD	SPEED (MAX)
Commercial	0°C to +70°C	IS61WV102416DALL	1.65V – 2.2V	12 ns ⁽¹⁾
		IS61WV102416DBLL	2.4V – 3.6V	10ns
Industrial	-40°C to +85°C	IS61WV102416DALL	1.65V – 2.2V	12 ns ⁽¹⁾
		IS61WV102416DBLL	2.4V – 3.6V	10ns
Automotive (A3)	-40°C to +125°C	IS64WV102416DALL	1.65V – 2.2V	12 ns
		IS64WV102416DBLL	2.4V – 3.6V	

Note:

1. Contact ISSI MKT for 1.8V 10ns device.

AC TEST CONDITIONS (OVER THE OPERATING RANGE)

Parameter	Unit (1.65V~2.2V)	Unit (2.4V~3.6V)
Input Pulse Level	0V to V_{DD}	0V to V_{DD}
Input Rise and Fall Time	1.5 ns	1.5 ns
Output Timing Reference Level	$\frac{1}{2} V_{DD}$	$\frac{1}{2} V_{DD}$
R1 (ohm)	13500	319
R2 (ohm)	10800	353
V_{TM} (V)	1.8V	3.3V
Output Load Conditions	Refer to Figure 1 and 2	

AC TEST LOADS

FIGURE 1

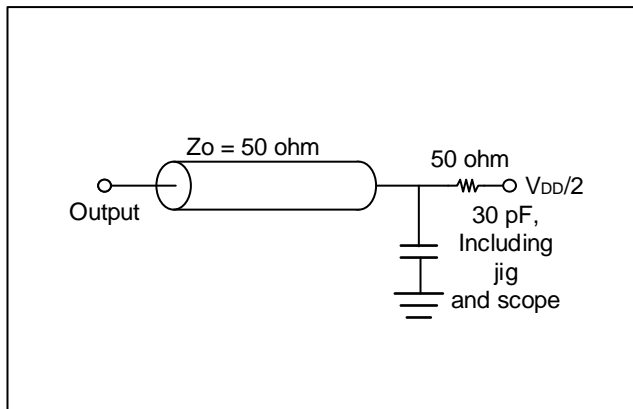
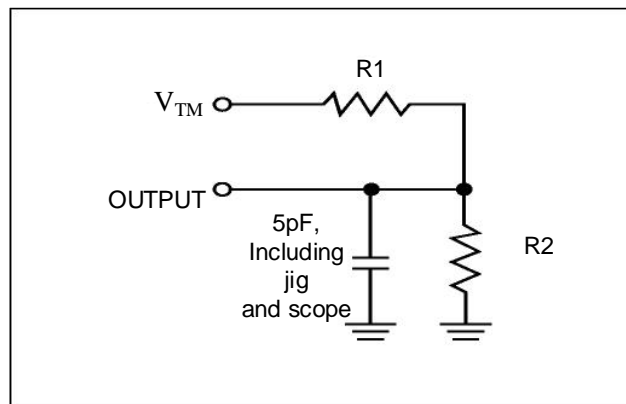

FIGURE 2



DC ELECTRICAL CHARACTERISTICS

DC ELECTRICAL CHARACTERISTICS-I (OVER THE OPERATING RANGE)

VDD = 1.65V – 2.2V

Symbol	Parameter	Test Conditions	Min.	Max.	Unit
V _{OH}	Output HIGH Voltage	I _{OH} = -0.1 mA	1.4	—	V
V _{OL}	Output LOW Voltage	I _{OL} = 0.1 mA	—	0.2	V
V _{IH} (¹)	Input HIGH Voltage		1.4	V _{DD} + 0.2	V
V _{IL} (¹)	Input LOW Voltage		-0.2	0.4	V
I _{LI}	Input Leakage	GND < V _{IN} < V _{DD}	-1	1	μA
I _{LO}	Output Leakage	GND < V _{IN} < V _{DD} , Output Disabled	-1	1	μA

Note:

- V_{ILL}(min) = -1.0V AC (pulse width < 10ns). Not 100% tested.
V_{IHH} (max) = V_{DD} + 1.0V AC (pulse width < 10ns). Not 100% tested.

DC ELECTRICAL CHARACTERISTICS-I (OVER THE OPERATING RANGE)

VDD = 2.4V – 3.6V

Symbol	Parameter	Test Conditions	Min.	Max.	Unit	
V _{OH}	Output HIGH Voltage	2.4V ~ 2.7V	V _{DD} = Min., I _{OH} = -1.0 mA	2.0	—	V
		2.7V ~ 3.6V	V _{DD} = Min., I _{OH} = -4.0 mA	2.2		
V _{OL}	Output LOW Voltage	2.4V ~ 2.7V	V _{DD} = Min., I _{OL} = 2.0 mA	—	0.4	V
		2.7V ~ 3.6V	V _{DD} = Min., I _{OL} = 8.0 mA	—	0.4	
V _{IH} (¹)	Input HIGH Voltage	2.4V ~ 2.7V		2.0	V _{DD} + 0.3	V
		2.7V ~ 3.6V		2.0		
V _{IL} (¹)	Input LOW Voltage	2.4V ~ 2.7V		-0.3	0.6	V
		2.7V ~ 3.6V		-0.3	0.8	
I _{LI}	Input Leakage	V _{SS} < V _{IN} < V _{DD}	-2	2	μA	
I _{LO}	Output Leakage	V _{SS} < V _{IN} < V _{DD} , Output Disabled	-2	2	μA	

Note:

- V_{IL}(min) = -0.3V DC ; V_{IL}(min) = -2.0V AC (pulse width 2.0ns). Not 100% tested.
V_{IH} (max) = V_{DD} + 0.3V DC ; V_{IH}(max) = V_{DD} + 2.0V AC (pulse width 2.0ns). Not 100% tested.

POWER SUPPLY CHARACTERISTICS-II FOR POWER ^(1, 2) (OVER THE OPERATING RANGE)
IS61/64WV102416DALL (V_{DD} = 1.65V – 2.2V) & IS61/64WV102416DBLL (V_{DD} = 2.4V – 3.6V)

Symbol	Parameter	Test Conditions	Grade	-10 Max.	-12 Max.	Unit
ICC	V _{DD} Dynamic Operating Supply Current	V _{DD} = MAX, I _{OUT} = 0 mA, f = f _{MAX}	Com.	90	85	mA
			Ind.	100	95	
			Auto.	140	135	
ICC1	Operating Supply Current	V _{DD} = MAX, I _{OUT} = 0 mA, f = 0	Com.	80	80	mA
			Ind.	90	90	
			Auto.	110	110	
ISB1	TTL Standby Current (TTL Inputs)	V _{DD} = MAX, V _{IN} = V _{IH} or V _{IL} CS# ≥ V _{IH} , f = 0	Com.	60	60	mA
			Ind.	70	70	
			Auto.	110	110	
ISB2	CMOS Standby Current (CMOS Inputs)	V _{DD} = MAX, CS# ≥ V _{DD} - 0.2V V _{IN} ≥ V _{DD} - 0.2V, or V _{IN} ≤ 0.2V, f = 0	Com.	50	50	mA
			Ind.	60	60	
			Auto.	100	100	
			Typ. ⁽²⁾	10		

Notes:

1. At f = f_{MAX}, address and data inputs are cycling at the maximum frequency, f = 0 means no input line change.
2. Typical values are measured at V_{DD} = 3.0V/1.8V, T_A = 25 °C and not 100% tested.

AC CHARACTERISTICS (OVER OPERATING RANGE)

READ CYCLE AC CHARACTERISTICS

Parameter	Symbol	-10 ⁽¹⁾		-12 ⁽¹⁾		unit	notes
		Min	Max	Min	Max		
Read Cycle Time	tRC	10	-	12	-	ns	
Address Access Time	tAA	-	10	-	12	ns	
Output Hold Time	tOHA	2.5	-	2.5	-	ns	
CS# Access Time	tACE	-	10	-	12	ns	
OE# Access Time	tDOE	-	6	-	7	ns	
OE# to High-Z Output	tHZOE	0	5	0	6	ns	2
OE# to Low-Z Output	tLZOE	0	-	0	-	ns	2
CS# to High-Z Output	tHZCE	0	5	0	6	ns	2
CS# to Low-Z Output	tLZCE	3	-	3	-	ns	2
UB#, LB# Access Time	tBA	-	6	-	7	ns	
UB#, LB# to High-Z Output	tHZB	0	5	0	6	ns	2
UB#, LB# to Low-Z Output	tLZB	0	-	0	-	ns	2

Notes:

1. Test conditions assume signal transition times of 1.5 ns or less, timing reference levels of $V_{DD}/2$, input pulse levels of 0V to V_{DD} and output loading specified in Figure 1.
2. Tested with the load in Figure 2. Transition is measured ± 500 mV from steady-state voltage. Not 100% tested.

AC WAVEFORMS

READ CYCLE NO. 1⁽¹⁾ (Address Controlled, CS# = OE# = UB# = LB# = LOW, WE# = HIGH)

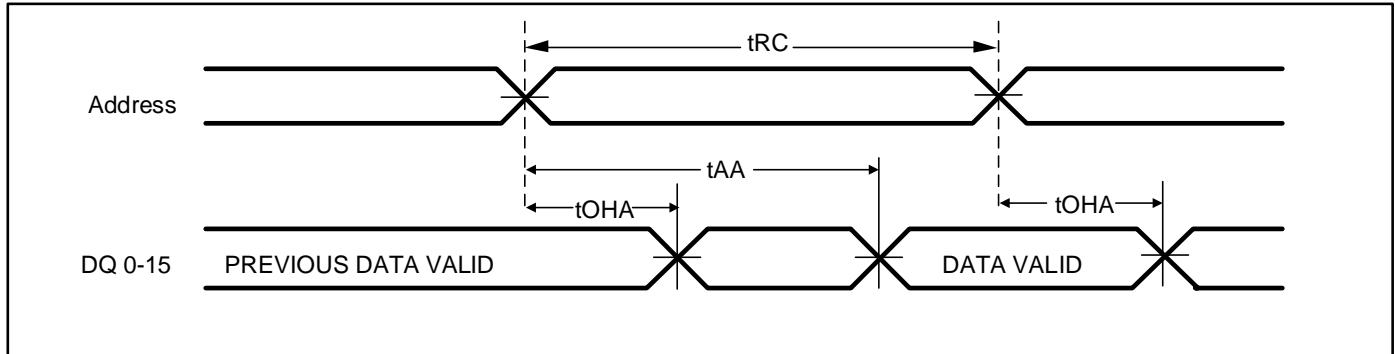

Notes:

1. The device is continuously selected.

READ CYCLE NO. 2⁽¹⁾ (OE# CONTROLLED, WE# = HIGH)

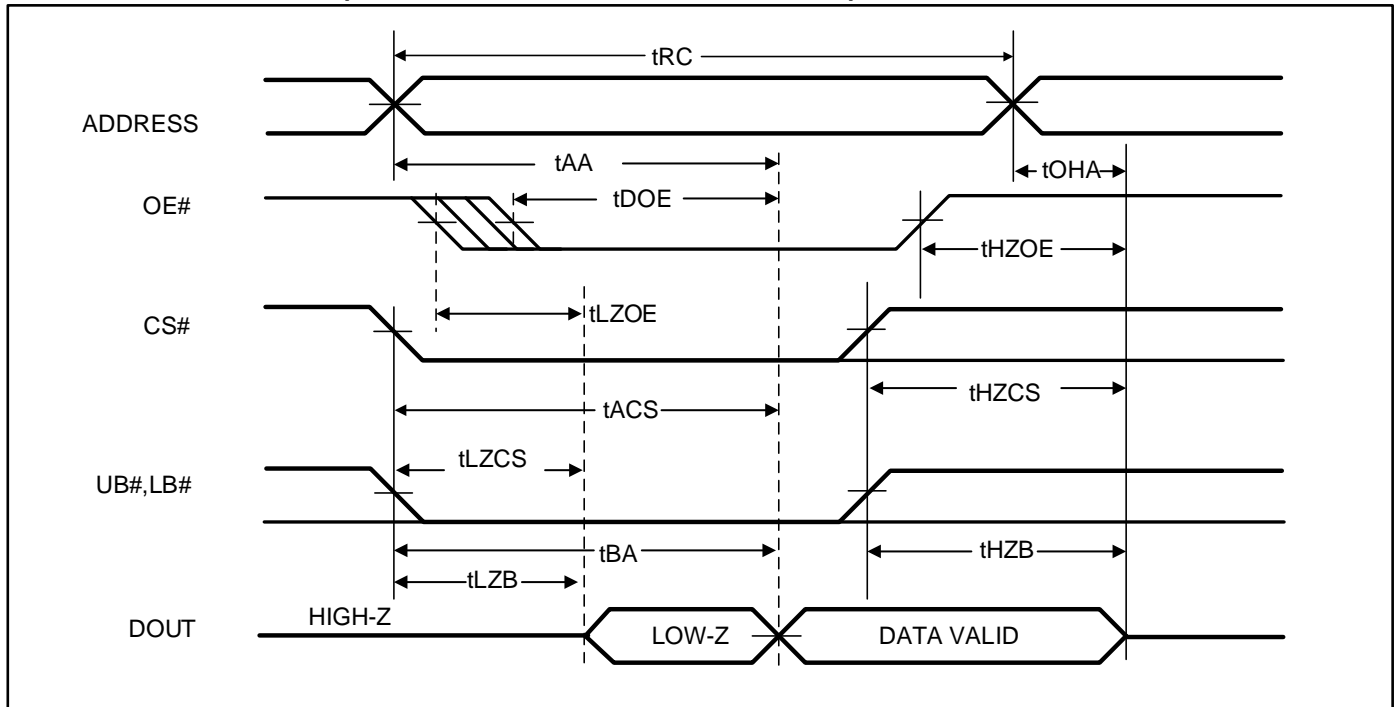

Notes:

1. Address is valid prior to or coincident with CS# LOW transition.

WRITE CYCLE AC CHARACTERISTICS

Parameter	Symbol	-10 ⁽¹⁾		-12 ⁽¹⁾		unit	notes
		Min	Max	Min	Max		
Write Cycle Time	tWC	10	-	12	-	ns	
CS# to Write End	tSCS	8	-	9	-	ns	
Address Setup Time to Write End	tAW	8	-	9	-	ns	
UB#,LB# to Write End	tPWB	8	-	9	-	ns	
Address Hold from Write End	tHA	0	-	0	-	ns	
Address Setup Time	tSA	0	-	0	-	ns	
WE# Pulse Width	tPWE1	8	-	9	-	ns	
WE# Pulse Width (OE# = LOW)	tPWE2	10	-	12	-	ns	2
Data Setup to Write End	tSD	6	-	7	-	ns	
Data Hold from Write End	tHD	0	-	0	-	ns	
WE# LOW to High-Z Output	tHZWE	-	4	-	5	ns	
WE# HIGH to Low-Z Output	tLZWE	2	-	2	-	ns	

Notes:

- 1 The internal write time is defined by the overlap of CS# = LOW, UB# or LB# = LOW, and WE# = LOW. All conditions must be in valid states to initiate a Write, but any condition can go inactive to terminate the Write. The Data Input Setup and Hold timing are referenced to the rising or falling edge of the signal that terminates the write.
- 2 Tested tPWE > tHZWE + tSD when OE# is LOW.

AC WAVEFORMS

WRITE CYCLE NO. 1⁽¹⁾ (CS# CONTROLLED, OE# = HIGH OR LOW)

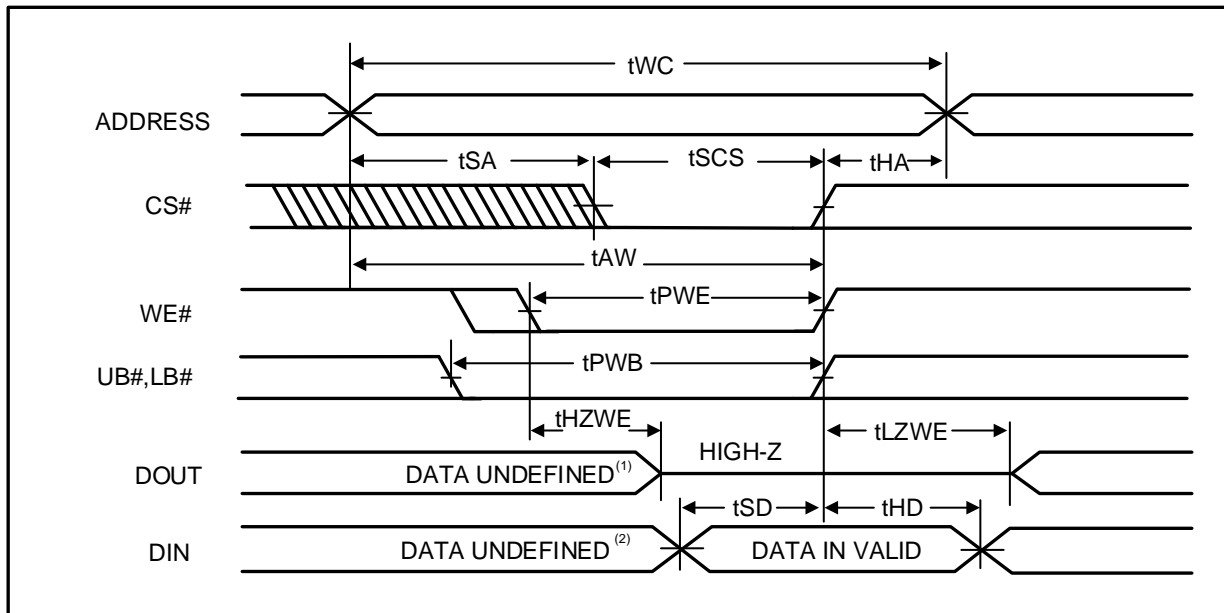

Note:

1. tHZWE is based on the assumption when tSA=0ns after READ operation. Actual DOUT for tHZWE may not appear if OE# goes high before Write Cycle.

WRITE CYCLE NO. 2^(1, 2) (WE# CONTROLLED: OE# IS HIGH DURING WRITE CYCLE)

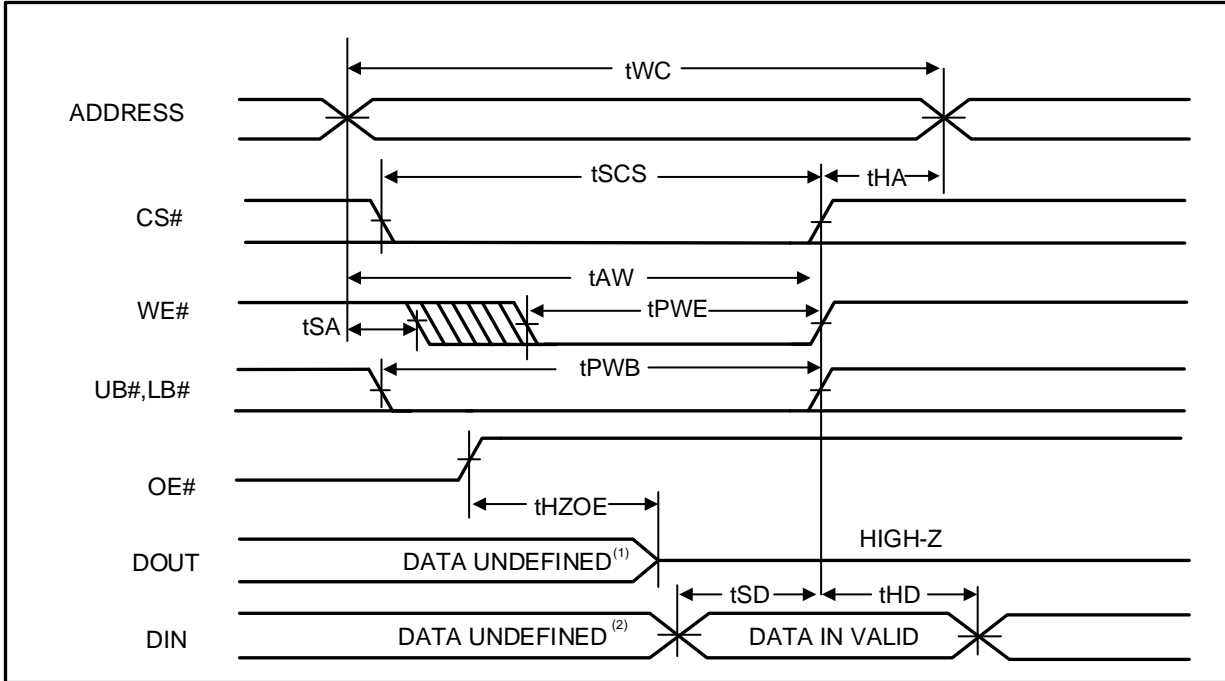

Notes:

1. tHZOE is the time DOUT goes to High-Z after OE# goes high.
2. During this period the I/Os are in output state. Do not apply input signals.

WRITE CYCLE NO. 3⁽¹⁾ (WE# CONTROLLED: OE# IS LOW DURING WRITE CYCLE)

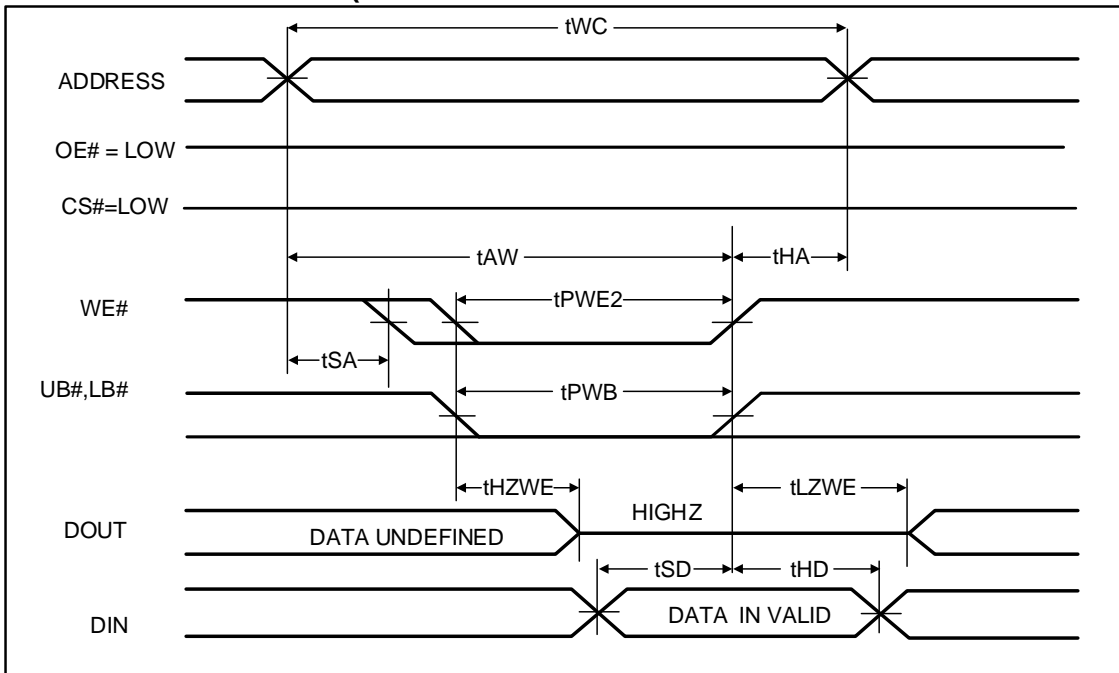

Note:

1. If OE# is low during write cycle, tHZWE must be met in the application. Do not apply input signal during this period. Data output from the previous READ operation will drive IO BUS.

WRITE CYCLE NO. 4^(1, 2, 3) (UB# & LB# Controlled, CS# = OE# = LOW)

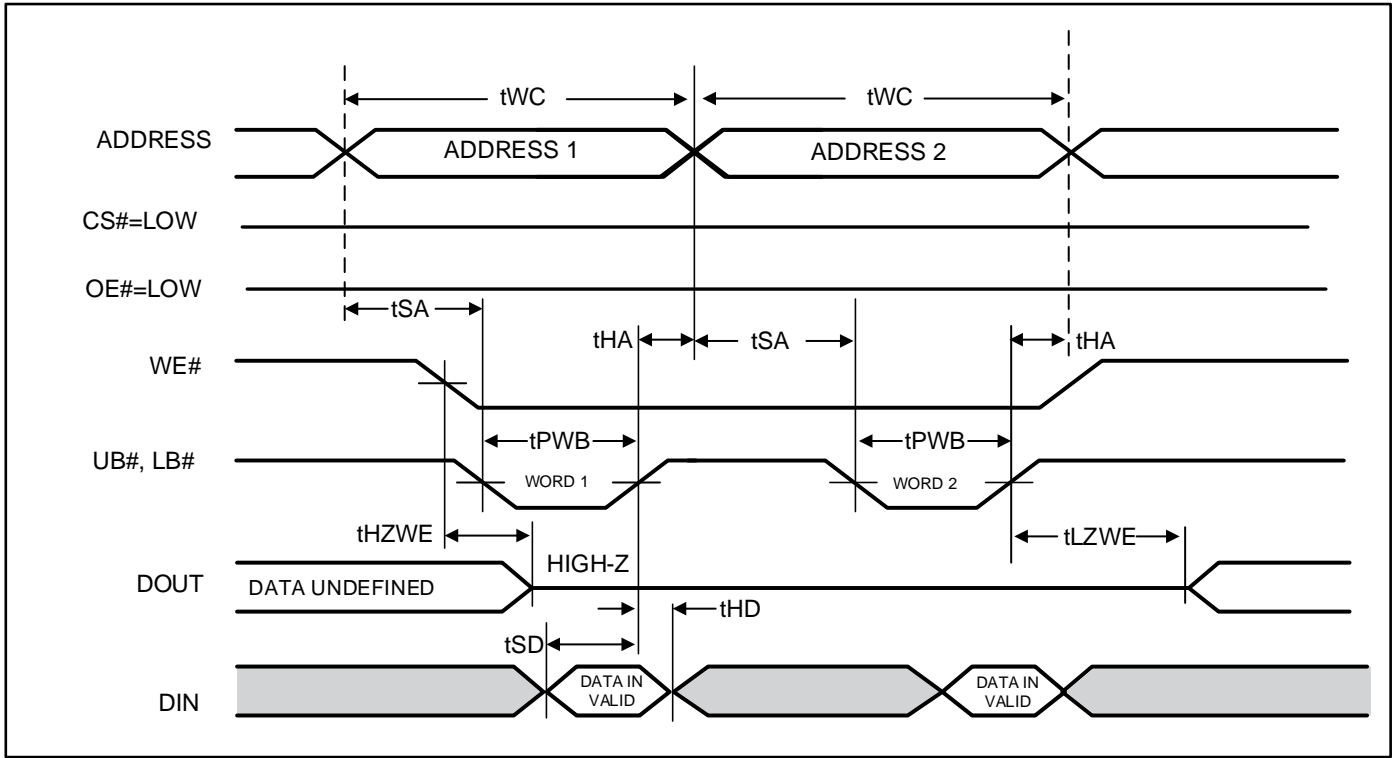

Notes:

1. If OE# is low during write cycle, t_{HZWE} must be met in the application. Do not apply input signal during this period. Data output from the previous READ operation will drive IO BUS.
2. Due to the restriction of note1, OE# is recommended to be HIGH during write period.
3. WE# stays LOW in this example. If WE# toggles, t_{PWE} and t_{HZWE} must be considered

DATA RETENTION CHARACTERISTICS

Symbol	Parameter	Test Condition	OPTION	Min.	Typ. ⁽²⁾	Max.	Unit
V _{DR}	V _{DD} for Data Retention	See Data Retention Waveform	V _{DD} = 2.4V to 3.6V	2.0		3.6	V
			V _{DD} = 1.65V to 2.2V	1.2		3.6	
I _{DR}	Data Retention Current	V _{DD} = V _{DR} (min), CS# ≥ V _{DD} - 0.2V	Com.	-	10	50	mA
			Ind.	-	-	60	
			Auto	-	-	100	
t _{SDR}	Data Retention Setup Time	See Data Retention Waveform		0	-	-	ns
t _{RDR}	Recovery Time	See Data Retention Waveform		t _{RC}	-	-	ns

Note:

1. If CS# ≥ V_{DD}-0.2V, all other inputs including UB# and LB# must meet this condition.
2. Typical values are measured at V_{DD} = V_{DR} (Min), T_A = 25 °C and not 100% tested.

DATA RETENTION WAVEFORM (CS# CONTROLLED)

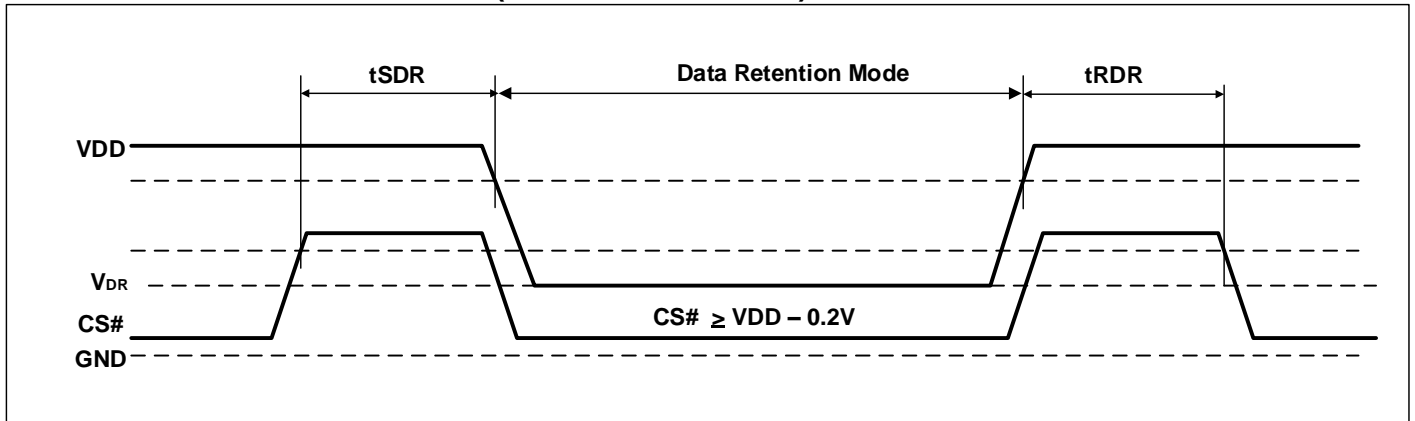

ORDERING INFORMATION

IS61/64WV102416DALL (1.65V – 2.2V)

Commercial Range: 0°C to +70°C

Speed (ns)	Order Part No.	Package
10	Contact ISSI MKT for 10ns	
12	IS61WV102416DALL-12B	mini BGA (6mm x 8mm)
12	IS61WV102416DALL-12BL	mini BGA (6mm x 8mm), Lead-free
12	IS61WV102416DALL-12TL	TSOP (Type I), Lead-free

Industrial Range: -40°C to +85°C

Speed (ns)	Order Part No.	Package
10	Contact ISSI MKT for 10ns	
12	IS61WV102416DALL-12BI	mini BGA (6mm x 8mm)
12	IS61WV102416DALL-12BLI	mini BGA (6mm x 8mm), Lead-free
12	IS61WV102416DALL-12TLI	TSOP (Type I), Lead-free

Automotive (A3) Range: -40°C to +125°C

Speed (ns)	Order Part No.	Package
12	IS64WV102416DALL-12BA3	mini BGA (6mm x 8mm)
12	IS64WV102416DALL-12BLA3	mini BGA (6mm x 8mm), Lead-free
12	IS64WV102416DALL-12CTLA3	TSOP (Type I), Copper Lead-frame, Lead-free

IS61/64WV102416DBLL (2.2V - 3.6V)

Commercial Range: 0°C to +70°C

Speed (ns)	Order Part No.	Package
10	IS61WV102416DBLL-10B	mini BGA (6mm x 8mm)
10	IS61WV102416DBLL-10BL	mini BGA (6mm x 8mm), Lead-free
10	IS61WV102416DBLL-10TL	TSOP (Type I), Lead-free

Industrial Range: -40°C to +85°C

Speed (ns)	Order Part No.	Package
10	IS61WV102416DBLL-10BI	mini BGA (6mm x 8mm)
10	IS61WV102416DBLL-10BLI	mini BGA (6mm x 8mm), Lead-free
10	IS61WV102416DBLL-10TLI	TSOP (Type I), Lead-free

Automotive (A3) Range: -40°C to +125°C

Speed (ns)	Order Part No.	Package
12	IS64WV102416DBLL-12BA3	mini BGA (6mm x 8mm)
12	IS64WV102416DBLL-12BLA3	mini BGA (6mm x 8mm), Lead-free
12	IS64WV102416DBLL-12CTLA3	TSOP (Type I), Copper Lead-frame, Lead-free

PACKAGE INFORMATION

SYMBOL	DIMENSION IN MM			DIMENSION IN INCH		
	MIN.	NOM.	MAX.	MIN.	NOM.	MAX.
A			1.20			0.047
A1	0.20		0.30	0.008		0.012
ϕ o	0.30	0.35	0.40	0.012	0.014	0.016
D	7.90	8.00	8.10	0.311	0.315	0.319
D1	5.25 BSC			0.207 BSC		
E	5.90	6.00	6.10	0.232	0.236	0.240
E1	3.75 BSC			0.148 BSC		
e	0.75 BSC.			0.030 BSC.		
ZD	1.375 REF.			0.054 REF.		
ZE	1.125 REF.			0.044 REF.		

TOP VIEW

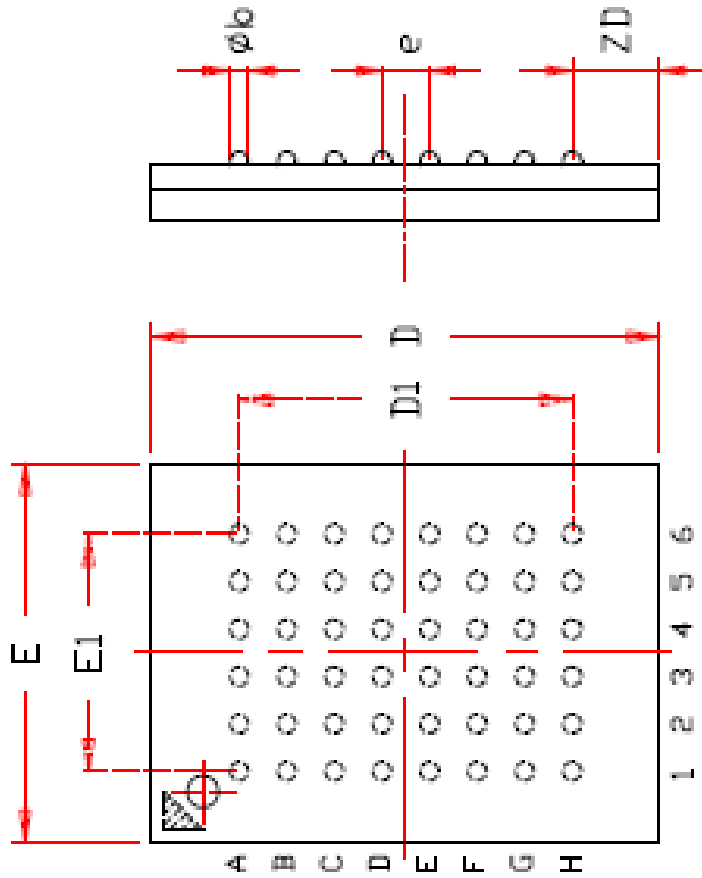

NOTE :

1. CONTROLLING DIMENSION : MM.
2. Reference document : JEDEC MO-207

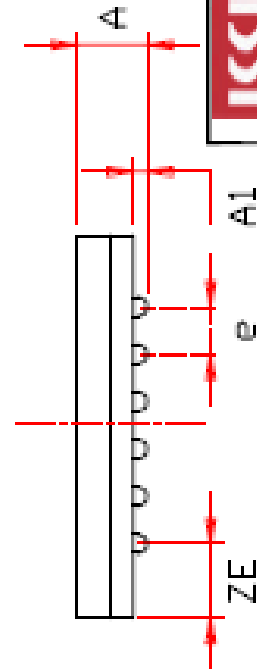

ISSI	TITLE	48L 6x8mm TF-BGA Package Outline	REV.	C	DATE	08/12/2008
-------------	-------	-------------------------------------	------	---	------	------------

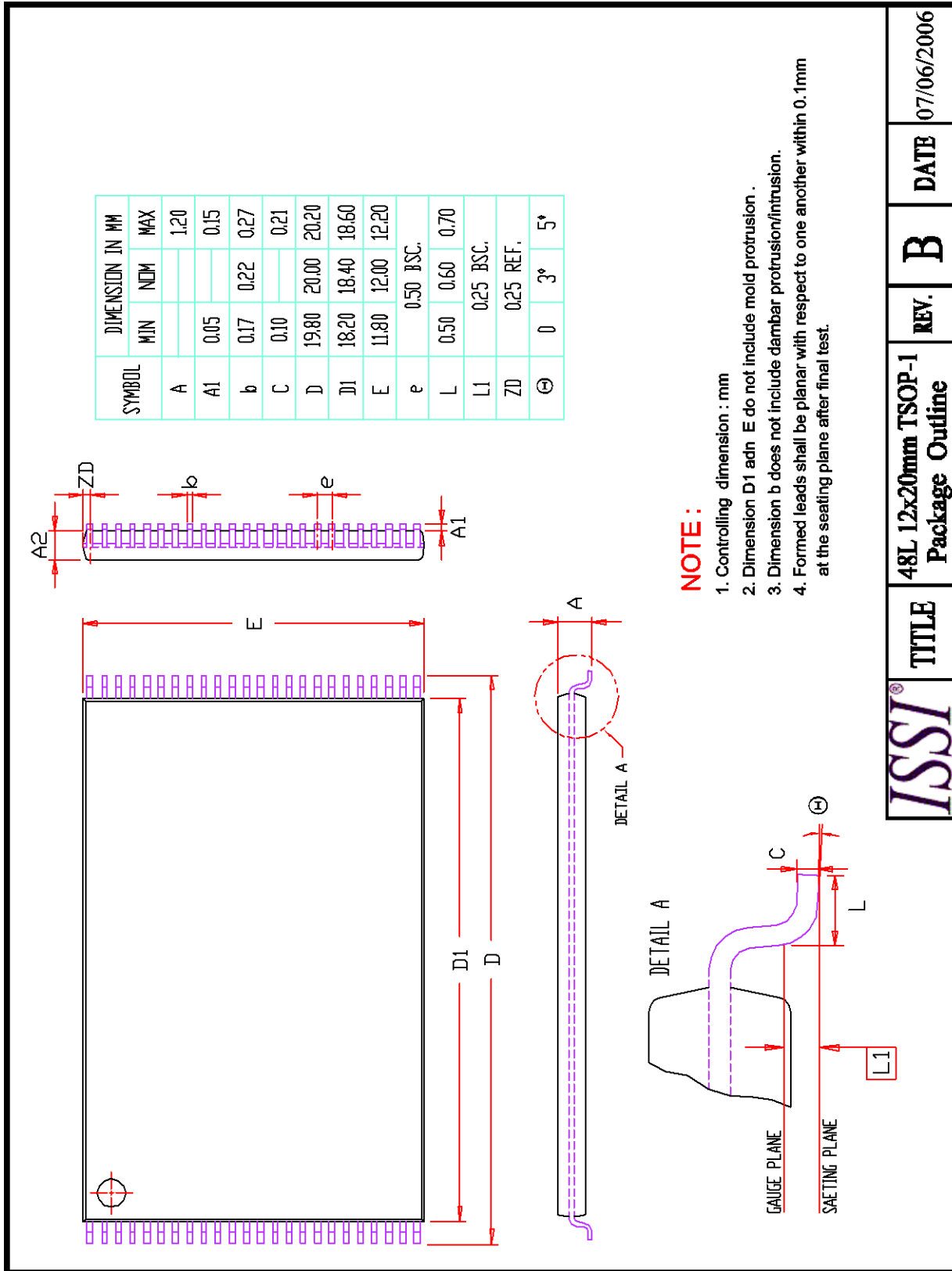

SYMBOL	DIMENSION IN MM	
	MIN	MAX
A		1.20
A1	0.05	0.15
b	0.17	0.22
c	0.10	0.21
D	19.80	20.20
D1	18.20	18.60
E	11.80	12.20
e	0.50 BSC.	
L	0.50	0.60
L1	0.25 BSC.	
ZD	0.25 REF.	
Θ	0	5°

NOTE :

1. Controlling dimension : mm
2. Dimension D1 and E do not include mold protrusion .
3. Dimension b does not include dambar protrusion/intrusion.
4. Formed leads shall be planar with respect to one another within 0.1mm at the seating plane after final test.

ISSI	TITLE	REV.	DATE
	48L 12x20mm TSOP-1 Package Outline	B	07/06/2006

Looking for pricing, stock, or lifecycle information?

Click below to explore more details on WIN SOURCE:

- ⊖ [View IS61WV102416DBLL-10BLI on WIN SOURCE](#)
- ⊖ [ISSI, Integrated Silicon Solution Inc Information](#)

Optimize Your Supply Chain with WIN SOURCE Solutions

- ✓ Global Sourcing Solution
- ✓ Obsolete Management
- ✓ Cost Control Management
- ✓ Shortage Management
- ✓ Alternative Solution
- ✓ Excess Inventory Management