



**THE DATASHEET OF  
BM1390GLV-ZTR**



Pressure Sensor series

# Pressure Sensor IC

## BM1390GLV-Z

### General Description

BM1390GLV-Z is piezo-resistive pressure sensor. BM1390GLV-Z performs temperature compensation for MEMS inside chip internally, so it's very easy to get pressure information. BM1390GLV-Z realizes waterproof by potting gel inside to protect.

### Key Specifications

- Pressure Range: 300 hPa to 1300 hPa
- Relative Pressure Accuracy: ±0.06 hPa(Typ)
- Absolute Pressure Accuracy: ±1 hPa(Typ)
- Operating Temperature Range: -40 °C to +85 °C

### Features

- Piezo-resistive pressure sensor
- Pressure range is from 300 hPa to 1300 hPa
- Built-in temperature compensation function.
- I<sup>2</sup>C bus interface (f/s mode support)
- Built-in FIFO
- Small package
- Waterproof

### Package

RLGA10VG020T

### W (Typ) x D (Typ) x H (Max)

2.0 mm x 2.0 mm x 1.0 mm

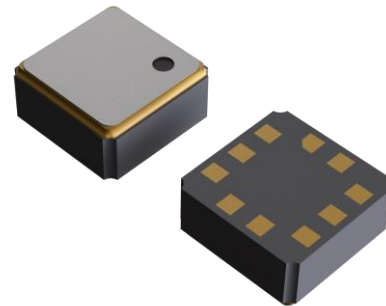

### Applications

- Smartphone, Healthcare, Mobile device (e.g. game).

### Typical Application Circuit and Block Diagram

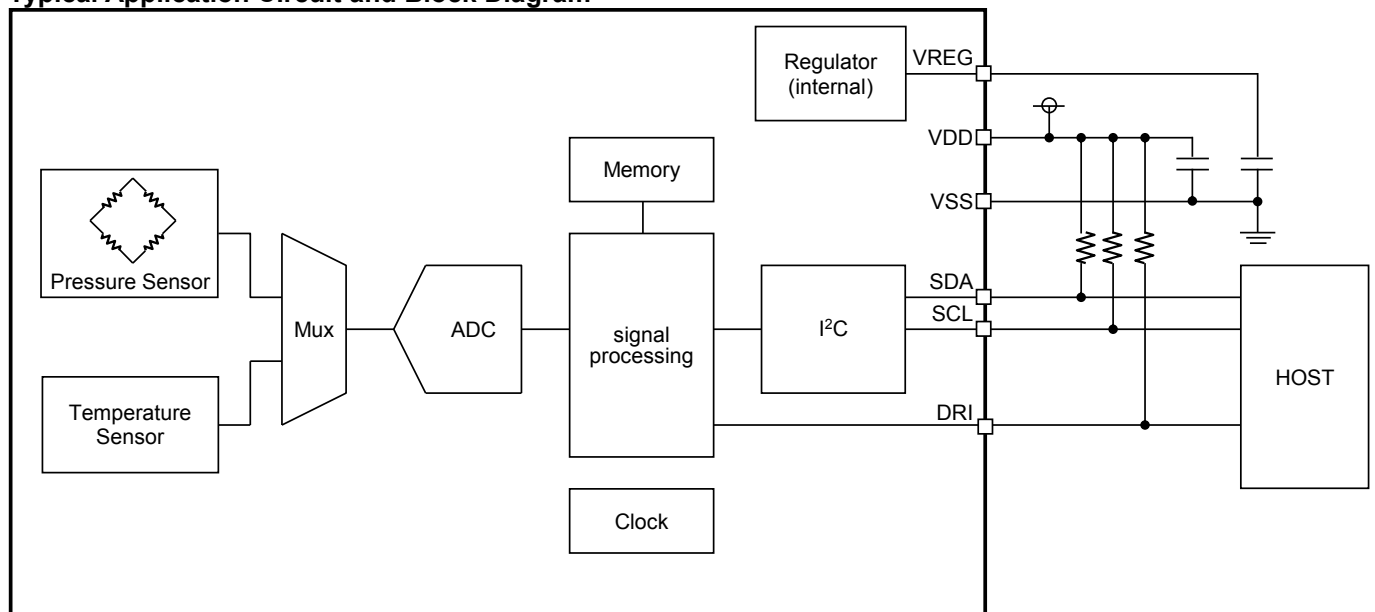

○Product structure : Silicon integrated circuit ○This product has no designed protection against radioactive rays.

## Contents

General Description .....	1
Features.....	1
Applications .....	1
Key Specifications .....	1
Package.....	1
Typical Application Circuit and Block Diagram.....	1
Pin Configuration .....	3
Pin Description.....	3
Absolute Maximum Ratings .....	4
Thermal Resistance.....	4
Recommended Operating Conditions .....	4
Electrical Characteristics.....	5
I <sup>2</sup> C Bus Timing Characteristics .....	6
I <sup>2</sup> C Bus Communication.....	6
I <sup>2</sup> C bus Slave Address .....	7
Register Map .....	7
FIFO .....	14
Interrupt function.....	16
Typical Performance Curves.....	17
Control Sequence.....	18
Application Example .....	23
I/O Equivalent Circuits .....	24
Operational Notes.....	25
Ordering Information.....	26
Marking Diagram.....	26
Physical Dimension and Packing Information .....	27
Revision History.....	28

Pin Configuration

Top View

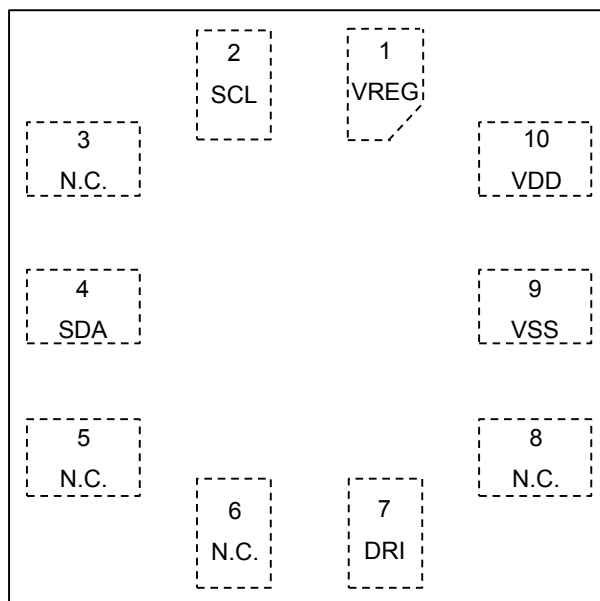

Pin Description

Pin No.	Pin Name	Function
1	VREG	Internal power supply pin <sup>(Note 1)</sup>
2	SCL	I2C serial bus clock pin <sup>(Note 2)</sup>
3	N.C.	No connection (Set to open)
4	SDA	I2C serial bus data pin <sup>(Note 2)</sup>
5	N.C.	No connection (Set to open)
6	N.C.	No connection (Set to open)
7	DRI	Interrupt notice output pin <sup>(Note 2)</sup>
8	N.C.	No connection (Set to open)
9	VSS	Ground pin
10	VDD	Power voltage pin <sup>(Note3)</sup>

(Note 1) Dispose a bypass capacitor as close as possible to the IC.  
 Dispose a bypass capacitor of 0.1 μF between VREG and VSS.  
 Do not use this pin for external power source.

(Note 2) When there is other device which is connected to the SDA, the SCL or the DRI pins and its signal falls sharply, that might generate undershoot and the pin voltage might go below ground. When such undershoot occurs, a measure like disposing a capacitor near the pins of the device must be taken.

(Note 3) Dispose a bypass capacitor as close as possible to the IC.

**Absolute Maximum Ratings (Ta = 25°C)**

Parameter	Symbol	Rating	Unit
Power Supply	V <sub>DD</sub>	4.5	V
Input Voltage <sup>1</sup> (Note 1)	V <sub>IN1</sub>	-0.3 to +4.5	V
Input Voltage <sup>2</sup> (Note 2)	V <sub>IN2</sub>	-0.3 to (V <sub>DD</sub> +0.3) or +4.5 whichever is less	V
Storage Temperature Range	T <sub>stg</sub>	-40 to +125	°C
Maximum Junction Temperature	T <sub>jmax</sub>	125	°C
Pressure	P <sub>OVr</sub>	20000	hPa

(Note 1) DRI, SCL, SDA pin

(Note 2) except DRI, SCL, SDA pin

**Caution 1:** Operating the IC over the absolute maximum ratings may damage the IC. The damage can either be a short circuit between pins or an open circuit between pins and the internal circuitry. Therefore, it is important to consider circuit protection measures, such as adding a fuse, in case the IC is operated over the absolute maximum ratings.

**Caution 2:** Should by any chance the maximum junction temperature rating be exceeded the rise in temperature of the chip may result in deterioration of the properties of the chip. In case of exceeding this absolute maximum rating, design a PCB with thermal resistance taken into consideration by increasing board size and copper area so as not to exceed the maximum junction temperature rating.

**Thermal Resistance**(Note 3)

Parameter	Symbol	Thermal Resistance (Typ)		Unit
		1s <sup>(Note 5)</sup>	2s2p <sup>(Note 6)</sup>	
RLGA10VG020T				
Junction to Ambient	θ <sub>JA</sub>	289.5	151.4	°C/W
Junction to Top Characterization Parameter <sup>(Note 4)</sup>	Ψ <sub>JT</sub>	73	62	°C/W

(Note 3) Based on JESD51-2A(Still-Air)

(Note 4) The thermal characterization parameter to report the difference between junction temperature and the temperature at the top center of the outside surface of the component package.

(Note 5) Using a PCB board based on JESD51-3.

(Note 6) Using a PCB board based on JESD51-7.

Layer Number of Measurement Board	Material	Board Size
Single	FR-4	114.3 mm x 76.2 mm x 1.57 mmt

Top	
Copper Pattern	Thickness
Footprints and Traces	70 μm

Layer Number of Measurement Board	Material	Board Size
4 Layers	FR-4	114.3 mm x 76.2 mm x 1.6 mmt

Top		2 Internal Layers		Bottom	
Copper Pattern	Thickness	Copper Pattern	Thickness	Copper Pattern	Thickness
Footprints and Traces	70 μm	74.2 mm x 74.2 mm	35 μm	74.2 mm x 74.2 mm	70 μm

**Recommended Operating Conditions**

Parameter	Symbol	Min	Typ	Max	Unit
Power Supply	V <sub>DD</sub>	1.7	1.8	3.6	V
Input Voltage <sup>(Note 7)</sup>	V <sub>IN1</sub>	0.0	-	3.6	V
I <sup>2</sup> C Clock Input Frequency	f <sub>SCL_I2C</sub>	-	-	400	kHz
Operating Temperature	T <sub>opr</sub>	-40	+25	+85	°C

(Note 7) DRI, SCL, SDA pin

Electrical Characteristics (Unless otherwise specified  $V_{DD} = 1.8\text{ V}$   $T_a = 25\text{ }^\circ\text{C}$ )

Parameter	Symbol	Min	Typ	Max	Unit	Conditions
Current Consumption						
Power Down Mode Current	$I_{SS}$	-	1	5	$\mu\text{A}$	PWR_DOWN = 0, RSTB = 0
Logic						
L Input Voltage <sup>(Note 1)</sup>	$V_{IL}$	-	-	$0.3 \times V_{DD}$	V	
H Input Voltage <sup>(Note 1)</sup>	$V_{IH}$	$0.7 \times V_{DD}$	-	-	V	
L Input Current <sup>(Note 1)</sup>	$I_{IL}$	-10	-	-	$\mu\text{A}$	$V_{IL} = \text{GND}$
H Input Current <sup>(Note 1)</sup>	$I_{IH}$	-	-	10	$\mu\text{A}$	$V_{IH} = V_{DD}$
L Output Voltage 1 <sup>(Note 2)</sup>	$V_{OL1}$	-	-	$0.2 \times V_{DD}$	V	$I_L = -0.3\text{ mA}$
L Output Voltage 2 <sup>(Note 3)</sup>	$V_{OL2}$	-	-	$0.2 \times V_{DD}$	V	$I_L = -3\text{ mA}$
Pressure characteristics						
Pressure Detection Range	$P_R$	300	-	1300	hPa	0 °C to 65 °C
Relative Pressure Accuracy <sup>(Note 4)</sup>	$P_{REL}$	-	$\pm 0.06$	-	hPa	950 hPa to 1050 hPa 10 hPa step
Absolute Pressure Accuracy	$P_{ABS}$	-	$\pm 1$	-	hPa	1000 hPa
Temperature Accuracy	$T_{ABS}$	-	$\pm 2$	-	°C	25 °C to 85 °C
Measurement Time <sup>(Note 5)</sup>	$t_M$	-	-	20	ms	AVE_NUM = 011

(Note 1) SDA, SCL pin

(Note 2) DR1 pin

(Note 3) SDA pin

(Note 4) Target values

(Note 5) Measurement time is changed by average number of measurement data. It is written in Measurement time more detail.

I<sup>2</sup>C Bus Timing Characteristics (Unless otherwise specified V<sub>DD</sub> = 1.8 V, Ta = 25 °C)

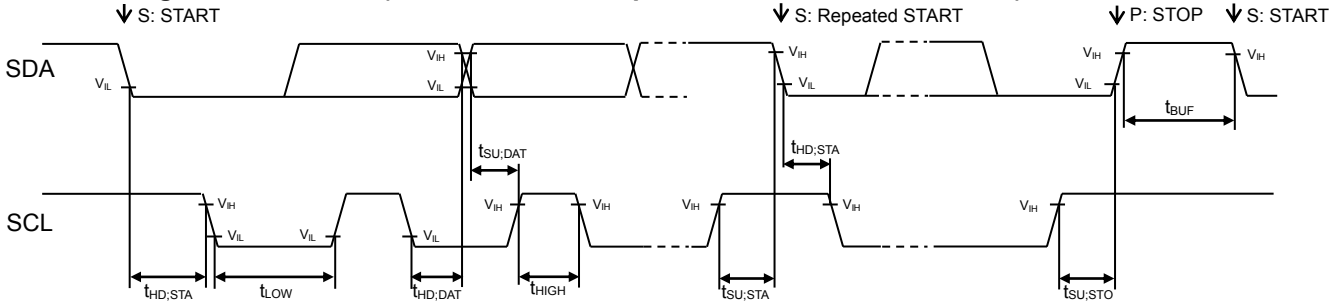

Parameter	Symbol	Min	Typ	Max	Unit	Conditions
SCL Clock frequency	f <sub>SCL</sub>	0	-	400	kHz	
'L' Period of the SCL Clock	t <sub>LOW</sub>	1.3	-	-	µs	
'H' Period of the SCL Clock	t <sub>HIGH</sub>	0.6	-	-	µs	
Setup Time for Repeated START	t <sub>SU,STA</sub>	0.6	-	-	µs	
Hold Time for START	t <sub>HD,STA</sub>	0.6	-	-	µs	
Data Setup Time	t <sub>SU,DAT</sub>	100	-	-	ns	
Data Hold Time	t <sub>HD,DAT</sub>	0	-	-	µs	
Setup Time for STOP	t <sub>SU,STO</sub>	0.6	-	-	µs	
Bus Free Time between STOP and START	t <sub>BUF</sub>	1.3	-	-	µs	

I<sup>2</sup>C Bus Communication

1. Write Format

(1) Indicate register address



(2) Write data after indicating register address

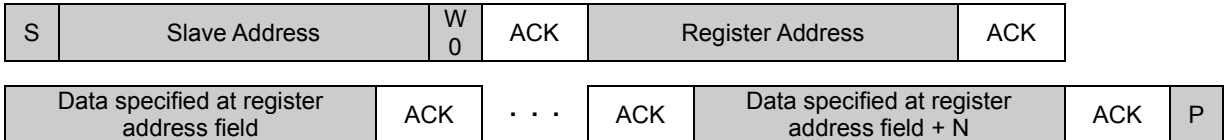

2. Read Format

(1) Read data after indicating register address

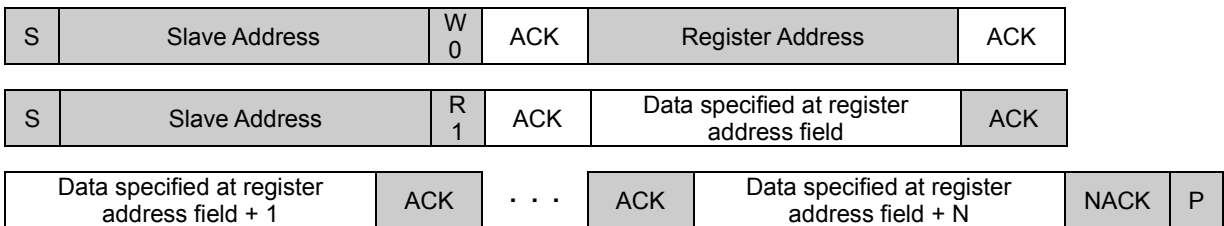

(2) Read data from the specified register

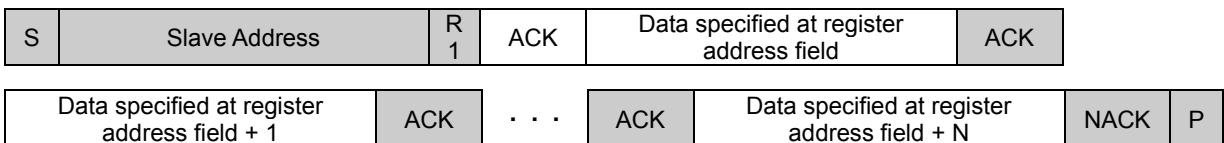

**I<sup>2</sup>C bus Slave Address**

The slave address is “1011101”.

**Register Map**<sup>(Note 1)</sup>

Register Address	Register Name	RW	D7	D6	D5	D4	D3	D2	D1	D0	
0x0F	MANUFACTURER ID	R	MANUFACTURER ID [7:0]								
0x10	PART ID	R	PART ID [7:0]								
0x12	POWER_DOWN	RW	0	0	0	0	0	0	0	PWR_DOWN	
0x13	RESET	RW	0	0	0	0	0	0	0	RSTB	
0x14	MODE_CONTROL	RW	AVE_NUM[2:0]			DR_EN	FULL_EN	WTM_EN	MODE[1:0]		
0x15	IIR, FIFO CONTROL	RW	FIFO_EN	WTM_LEVEL	0	0	0	0	IIR_MODE[1:0]		
0x18	FIFO data	R	0	0	0	0	0	FIFO_LEV[2:0]			
0x19	STATUS	R	0	0	0	0	0	RD_FULL	RD_WTM	RD_DRDY	
0x1A	PRESSURE	R	PRESS_OUT[15:8]								
0x1B		R	PRESS_OUT[7:0]								
0x1C		R	PRESS_OUT_XL[5:0]						0	0	
0x1D	TEMPERATURE	R	TEMP_OUT[15:8]								
0x1E		R	TEMP_OUT[7:0]								

(Note 1) Do not write any commands to other addresses except above. Do not write '1' to the fields in which value is '0' in above table.  
 Address from 0x14 to 0x1E registers can be accessed only when PWR\_DOWN = 1 and RSTB = 1. (In other case Write: Ignored, Read: 0xFF)

Register Map – continued

(0x0F) MANUFACTURER ID

Fields	Function
MANUFACTURER ID [7:0]	Manufacturer ID: 0xE0

(0x10) PART ID

Fields	Function
PART ID [7:0]	Part ID: 0x34

(0x12) POWER\_DOWN

Fields	Function
PWR_DOWN	0: power down 1: active

default value 0x00

(0x13) RESET

Fields	Function
RSTB	0: Measurement control block is reset 1: Measurement control block is active

default value 0x00

Register Map – continued

(0x14) MODE\_CONTROL

Fields	Function
AVE_NUM[2:0]	Setting of the averaging number of measurement data 011: 8 times, 100: 16 times, 101: 32 times, 110: 64 times, other: Prohibited
DR_EN	DRI pin Enable for Data Ready Details are written in Interrupt. 0: DRI pin Disable, 1: DRI pin Enable
FULL_EN	DRI pin Enable for FULL Details are written in Interrupt. 0: DRI pin Disable, 1: DRI pin Enable
WTM_EN	DRI pin Enable for Water Mark Details are written in Interrupt. 0: DRI pin Disable, 1: DRI pin Enable
MODE[1:0]	Measurement mode setting (Pressure and Temperature are measured at one rate) 00: Standby, 01: One shot, 10: Continuous, 11: Prohibited

default value 0x00

(0x15) IIR, FIFO CONTROL

Fields	Function
FIFO_EN	FIFO mode setting Details are written in FIFO. 0: Bypass mode, 1: FIFO mode
WTM_LEVEL	Water Mark level setting Details are written in FIFO. 0: Water Mark interrupt occur when FIFO memory is 2 or above. 1: Water Mark interrupt occur when FIFO memory is 3 or above.
IIR_MODE[1:0]	IIR filter enable and coefficient setting 00: IIR OFF, 01: IIR ON (weak) 10: IIR ON (middle), 11: IIR ON (strong) When using IIR filter, set 110 to "AVE_NUM" and 10 to "MODE".

default value 0x00

Measurement time and RMS noise against number of average

AVE_NUM	IIR_MODE	Measurement time $t_M$ max[ms]	Measurement cycle $t_i$ max[ms]	RMS noise [hPa]
011	00	20	25	0.032
100	00	40	50	0.023
101	00	76	100	0.016
110	00	152	200	0.011
110	01	152	200	0.0072
110	10	152	200	0.0034
110	11	152	200	0.0016

RMS noise is calculated as standard deviation of 32 data points (1 $\sigma$ ).  
RMS noise is a reference value and it's not the value with guarantee.  
Condition  $V_{DD} = 1.8\text{ V}$ ,  $T_a = 25\text{ }^\circ\text{C}$

Register Map – continued

Measurement time

One shot mode performs one measurement. Measurement data is updated when measurement completed, so it should be read more than  $t_M$  after measurement start.  
 Continuous mode repeats measurement in every measurement cycle  $t_i$ . The latest measurement data which is completed is read.  
 Measurement time  $t_M$  and measurement cycle  $t_i$  is determined by number of average.

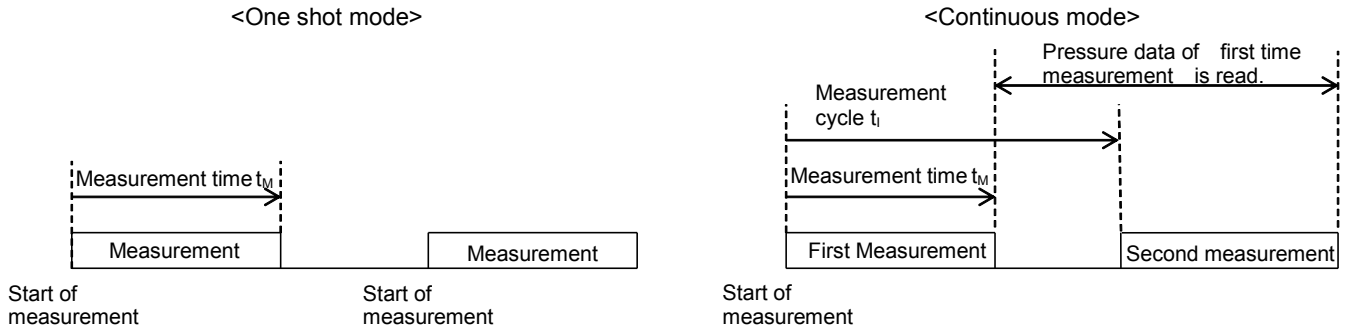

IIR filter

RMS noise can be reduced by setting IIR filter in addition to the setting of number of averaging. When IIR filter is ON and pressure input fluctuates, a response time  $t_R$  to reach a target value delays.

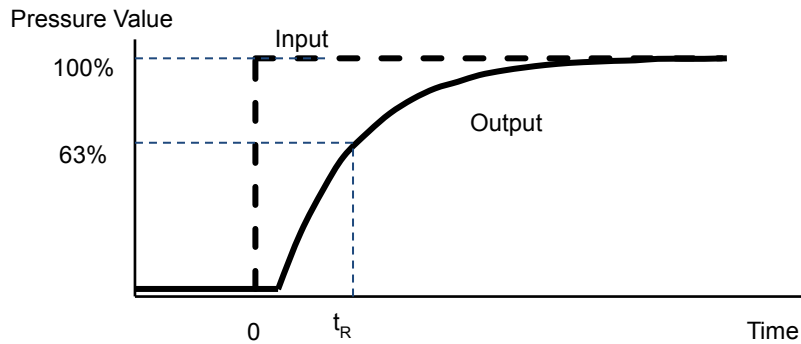

Response time against IIR coefficient

AVE_NUM	IIR_MODE	Response time $t_R$ [ms]
110	01	352
110	10	952
110	11	3352

Response time is a reference value and it's not the value with guarantee.  
 Condition  $V_{DD} = 1.8\text{ V}$ ,  $T_a = 25\text{ }^\circ\text{C}$ , MODE = 10

Register Map – continued

Operation mode transition

Operation mode transition is like the chart below.

Power down mode is the smallest current consumption mode due to circuit is OFF. Set this mode when reducing current consumption. Measurement is not available in this mode, so the measurement is performed after switching to standby mode.

In reset mode, regulator for internal blocks is active and measurement control block is reset. Register is initialized in Reset mode. Measurement command is acceptable when “1” is written in “RSTB”

There are 2 measurement modes. One shot mode and Continuous mode. They are transferred from standby mode. Then, set “AVE\_NUM” register at the same time.

Write “00” in “MODE” (address = 0x14) when transferring to standby mode again.

In one shot mode, a single measurement is performed when “01” is written in “MODE”. After the measurement completes, it is transferred to standby mode automatically. When “00” is written in “MODE” before end of measurement, mode is switched to standby immediately but pressure value is not updated. Transition to the other measurement mode during measurement in one shot mode is forbidden.

In Continuous mode, when “10” is written in “MODE”, measurement starts and it continues until “00” is written in “MODE”. Transition to the other measurement mode from Continuous mode is forbidden.

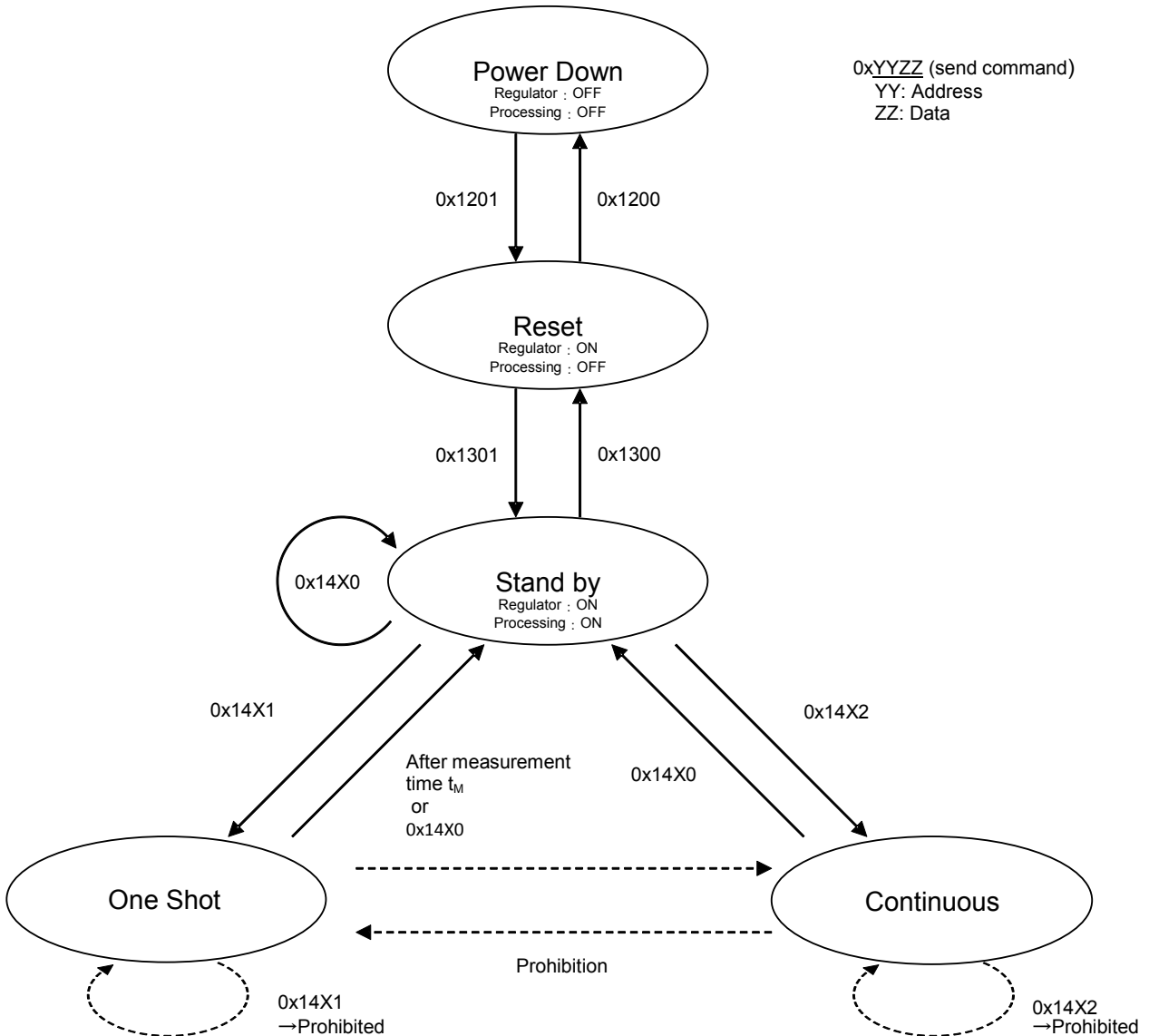

Register Map – continued

(0x18) FIFO data

Fields	Function
FIFO_LEV[2:0]	Number of sample in FIFO

default value 0x00

FIFO\_LEV[2:0]

D2	D1	D0	Description
0	0	0	FIFO empty
0	0	1	Number of sample in FIFO = 1
0	1	0	Number of sample in FIFO = 2
0	1	1	Number of sample in FIFO = 3
1	0	0	FIFO FULL

(0x19) STATUS

Fields	Function
RD_FULL	FIFO overrun (FULL) status This register is cleared when this is read. RD_FULL is not updated unless data are read. 0: FIFO is not full; 1: FIFO is full.
RD_WTM	FIFO threshold (Water Mark) status This register is cleared when FIFO memory become less than threshold level. 0: Number of sample in FIFO is lower than threshold level. 1: Number of sample in FIFO is equal or higher than threshold level.
RD_DRDY	Pressure and temperature measurement data ready bit This register is cleared when '1' is read. Do not care RD_DRDY in FIFO mode (FIFO_EN = 1). 0: data is not updated 1: data is updated

default value 0x00

Register Map – continued

(0x1A / 0x1B / 0x1C) PRESSURE

Fields	Function
PRESS_OUT[15:0] PRESS_OUT_XL[5:0]	pressure data

default value 0x000000

Conversion to pressure value is below.

$$\text{Pressure counts} = \text{PRESS\_OUT}[15:8] \times 2^{14} + \text{PRESS\_OUT}[7:0] \times 2^6 + \text{PRESS\_OUT\_XL}[5:0] \text{ [counts] (dec)}$$

$$\text{Pressure value [hPa]} = \text{Pressure counts [counts]} / 2048 \text{ [counts/hPa]}$$

Data registers (0x1A, 0x1B, 0x1C) should be read by burst read.  
Data is updated at the timing of measurement completion.  
If they are not read by burst read, data might be mixed up with the data of different measurement.

(0x1D / 0x1E) TEMPERATURE

Fields	Function
TEMP_OUT[15:0]	temperature data

default value 0x0000

Conversion to temperature value is below. Note that TEMP\_OUT is data with sign (two's complement).

$$\text{Temp counts} = \text{TEMP\_OUT}[15:8] \times 2^8 + \text{TEMP\_OUT}[7:0] \text{ [counts] (dec)}$$

$$\text{Temperature value [}^\circ\text{C]} = \text{Temp counts [counts]} / 32 \text{ [counts/}^\circ\text{C]}$$

(in case of positive number)

Data registers (0x1D,0x1E) should be read by burst read.  
Data is updated at the timing of measurement completion.  
If they are not read by burst read, data might be mixed up with the data of different measurement.

FIFO

This IC embeds a 4-slot FIFO to store the pressure and temperature output values.

FIFO has Bypass mode (FIFO\_EN = 0) and FIFO mode (FIFO\_EN = 1).

In FIFO mode, the pressure output data are stored in FIFO when measurement is completed.

The data is read from oldest data. Temperature output data are not stored in FIFO.

Interrupt for WTM and FULL is available in FIFO mode.

WTM interrupt is enable when WTM\_EN is set to '1'. In this mode, when FIFO memory reach the number set in WTM\_LEVEL, RD\_WTM goes to '1'.

FULL interrupt is enable when FULL\_EN is set to '1'. In this mode, when 4 data are stored in FIFO, RD\_FULL goes to '1'.

FIFO\_LEV is the number of sample in FIFO.

FIFO is only available in Continuous mode.

<Bypass mode>

FIFO is not operational in Bypass mode (FIFO\_EN = 0).

New data is overwritten to old data due to only the first slot of FIFO is in use.

FIFO and FIFO\_LEV are initialized in Bypass mode.

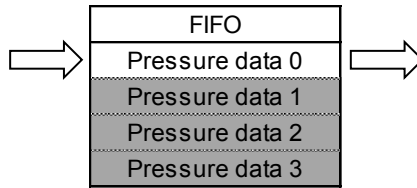

<FIFO mode>

FIFO is operational in FIFO mode (FIFO\_EN = 1).

Pressure data is read from the address 0x1A, 0x1B and 0x1C.

The data is read from oldest data. FIFO stops storing data when FIFO is FULL.

The latest temperature data is read from the address 0x1D and 0x1E.

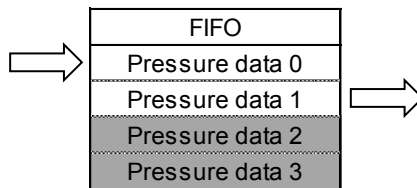

FIFO – continued

Water Mark interrupt

Water Mark interrupt occur when stored data in FIFO is equal to or more than the number set in WTM\_LEVEL.  
 Water Mark level is selectable from 2 (WTM\_LEVEL = 0) and 3 (WTM\_LEVEL = 1).  
 RD\_WTM goes to '1' when Water Mark interrupt occur  
 Water Mark interrupt keep active state while FIFO\_LEV is equal to or more than WTM\_LEVEL. And it is released, when FIFO\_LEV go below WTM\_LEVEL.  
 The DRI pin status is determined by Water Mark interrupt, when WTM\_EN is '1'.

Case of Water Mark occurs at 2 of Water Mark level

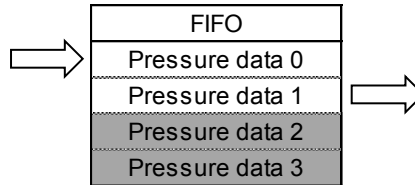

FULL interrupt

FULL interrupt occur when stored data in FIFO is 4. RD\_FULL goes '1'.  
 RD\_FULL goes '0' when RD\_FULL is read.  
 FIFO and RD\_FULL are not updated by measurement after FULL interrupt occur. Then FIFO\_LEV is fixed to 4.  
 The DRI pin status is determined by FULL interrupt, when FULL\_EN is '1'.

Case of FULL occurs

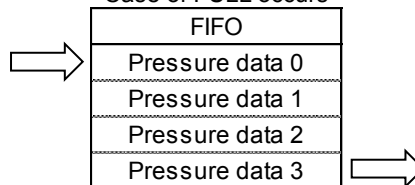

**Interrupt Function**

Interrupt factor is Data Ready, FIFO FULL and FIFO WTM.

The condition is listed below.

The status register is always operational.

The status register goes '1' when interrupt occur.

When the DRI pin enable register for each factor is '1', the DRI pin status is determined by the interrupt state of factor.

When interrupt occur, the DRI pin output 'L'.

The status register and the DRI pin keeps the state until the interrupt is cleared.

FIFO FULL and FIFO WTM are not available in Bypass mode (FIFO\_EN = 0)

Do not care Data Ready in FIFO mode (FIFO\_EN = 1).

**Interrupt factor**

Factor	Status Register	Interrupt Condition	Interrupt Clear Condition
Data Ready	RD_DRDY	Measurement completion	Read RD_RDRY
FIFO FULL	RD_FULL	FIFO is Full	Read RD_FULL
FIFO WTM	RD_WTM	FIFO_LEV ≥ WTM level	FIFO_LEV < WTM level

**Relation between factor and the DRI pin enable**

Factor	DRI Pin Enable
Data Ready	DR_EN
FIFO FULL	FULL_EN
FIFO WTM	WTM_EN

The DRI pin is Nch open drain so this pin should be pull-up to voltage source by an external resister.

The DRI pin is high impedance just after VDD is supplied.

The DRI pin becomes inactive (High impedance) by reading RD\_DRDY register or setting reset mode.

VDD current (approximately 6 μA at V<sub>DD</sub> = 1.8 V) is consumed during DRI is active.

When disabling interrupt function, it has to be done after clearing interrupt.

**<Example of Data Ready interrupt: 1shot mode>**

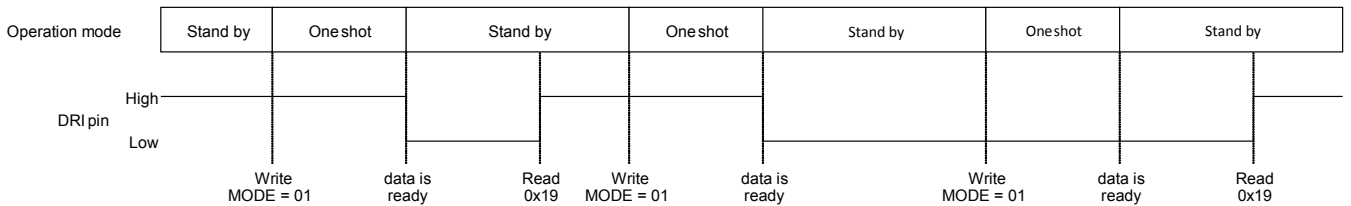

**Typical Performance Curves**

(Reference data)

(Unless otherwise specified  $V_{DD} = 1.8\text{ V}$   $T_a = 25\text{ }^\circ\text{C}$ )

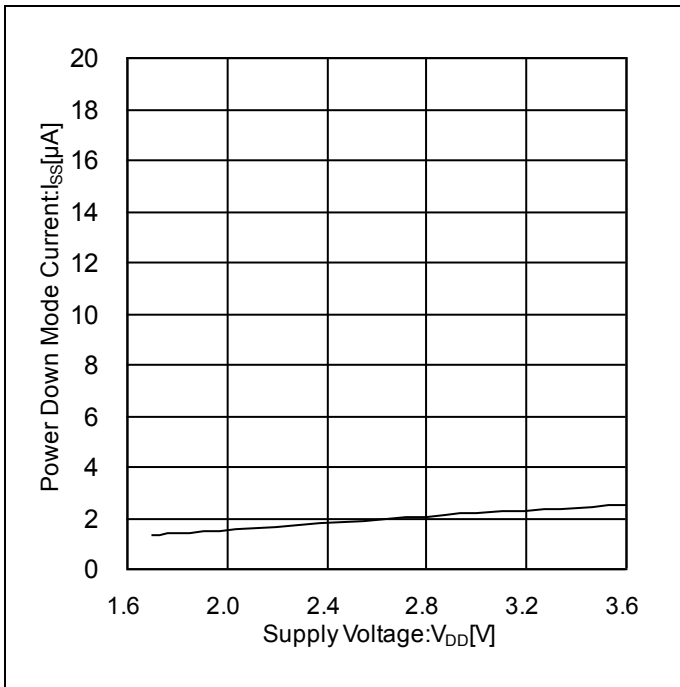

Figure 1. Power Down Mode Current vs Supply Voltage  
(PWR\_DOWN = 0, RSTB = 0)

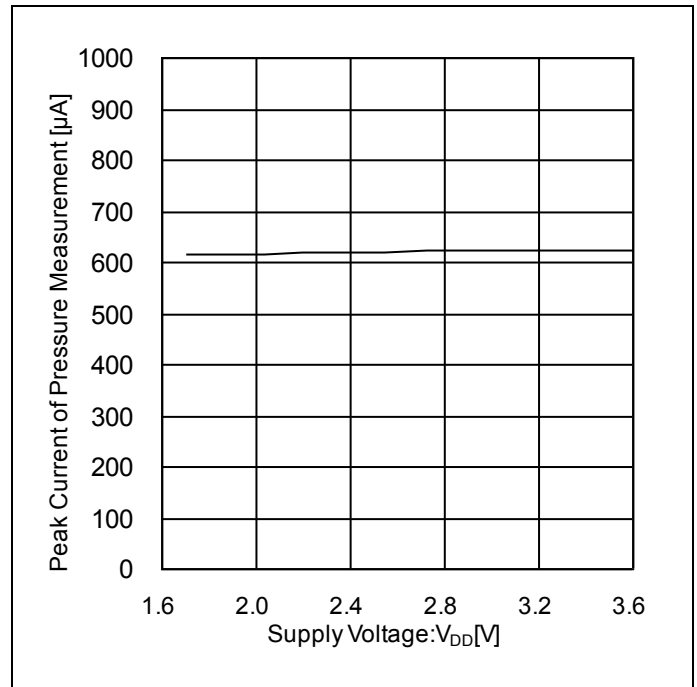
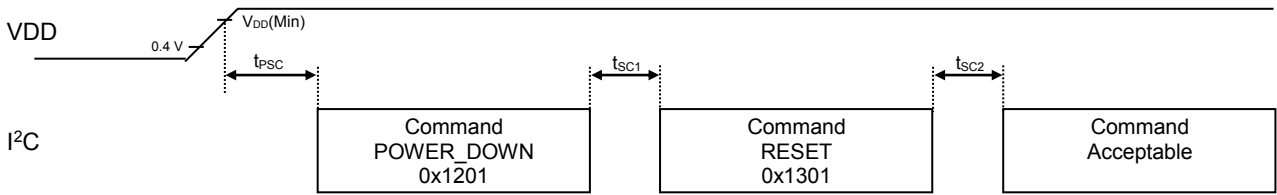

Figure 2. Peak Current of Pressure Measurement vs Supply Voltage  
(During measurement)

Control Sequence

1. Power-on Sequence



Parameter	Symbol	Min	Typ	Max	Unit	Conditions
Command input time after power-on	t <sub>PSC</sub>	100	-	-	μs	
Reset cancel wait time	t <sub>SC1</sub>	1	-	-	ms	VREG: 0.1 μF
Measurement command wait time	t <sub>SC2</sub>	100	-	-	μs	

t<sub>PSC</sub> after VDD power-on, command can be input.

Send reset cancel command (RSTB = 1) more than t<sub>SC1</sub> after regulator for internal blocks become active (PWR\_DOWN = 1).  
Send measurement command more than t<sub>SC2</sub> after reset cancel command.

2. Power-off sequence

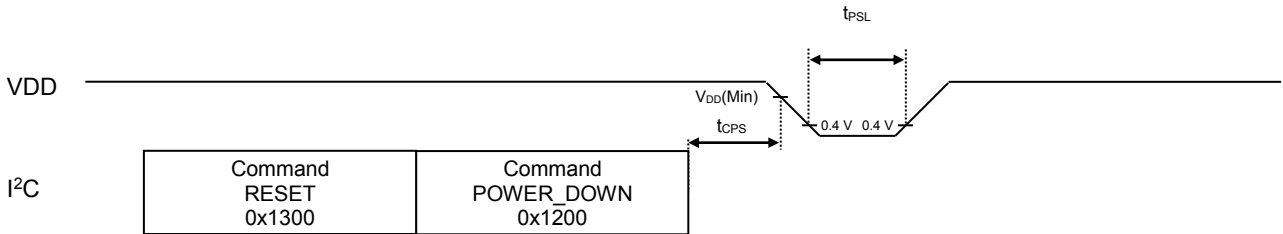

Parameter	Symbol	Min	Typ	Max	Unit	Conditions
Wait time from power down command	t <sub>CPS</sub>	0	-	-	μs	
Power supply OFF time	t <sub>PSL</sub>	1	-	-	ms	

Send reset command (RSTB = 0) to turn regulator for internal blocks off (PWR\_DOWN = 0) t<sub>CPS</sub> before the VDD power-off.  
Keep VDD Low (V<sub>DD</sub> < 0.4 V) more than t<sub>PSL</sub> before VDD power-on

Control sequence – continued

3. Starting sequence

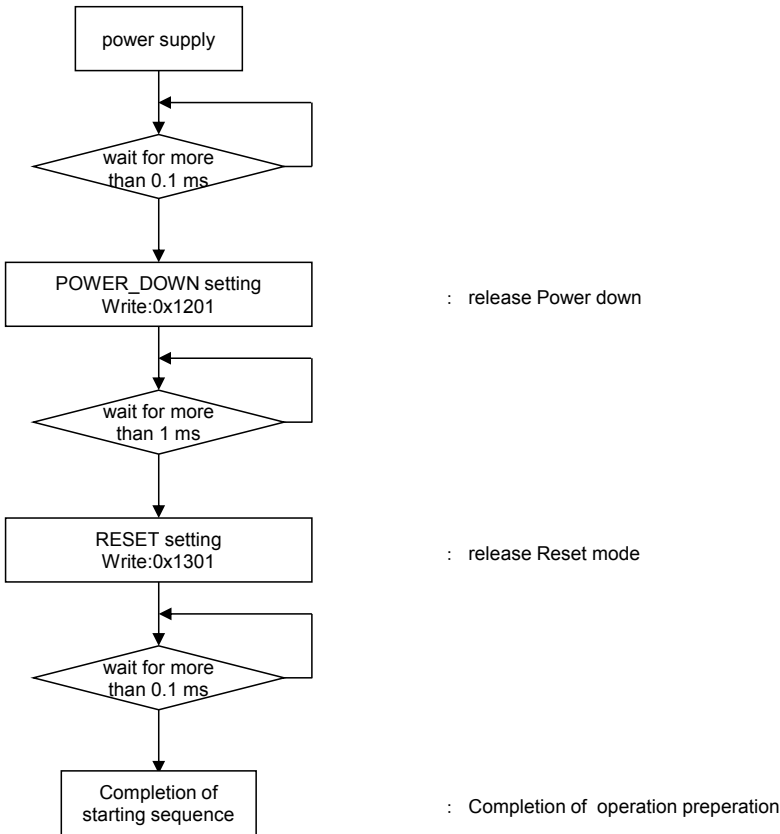

4. Measurement sequence: One Shot Mode

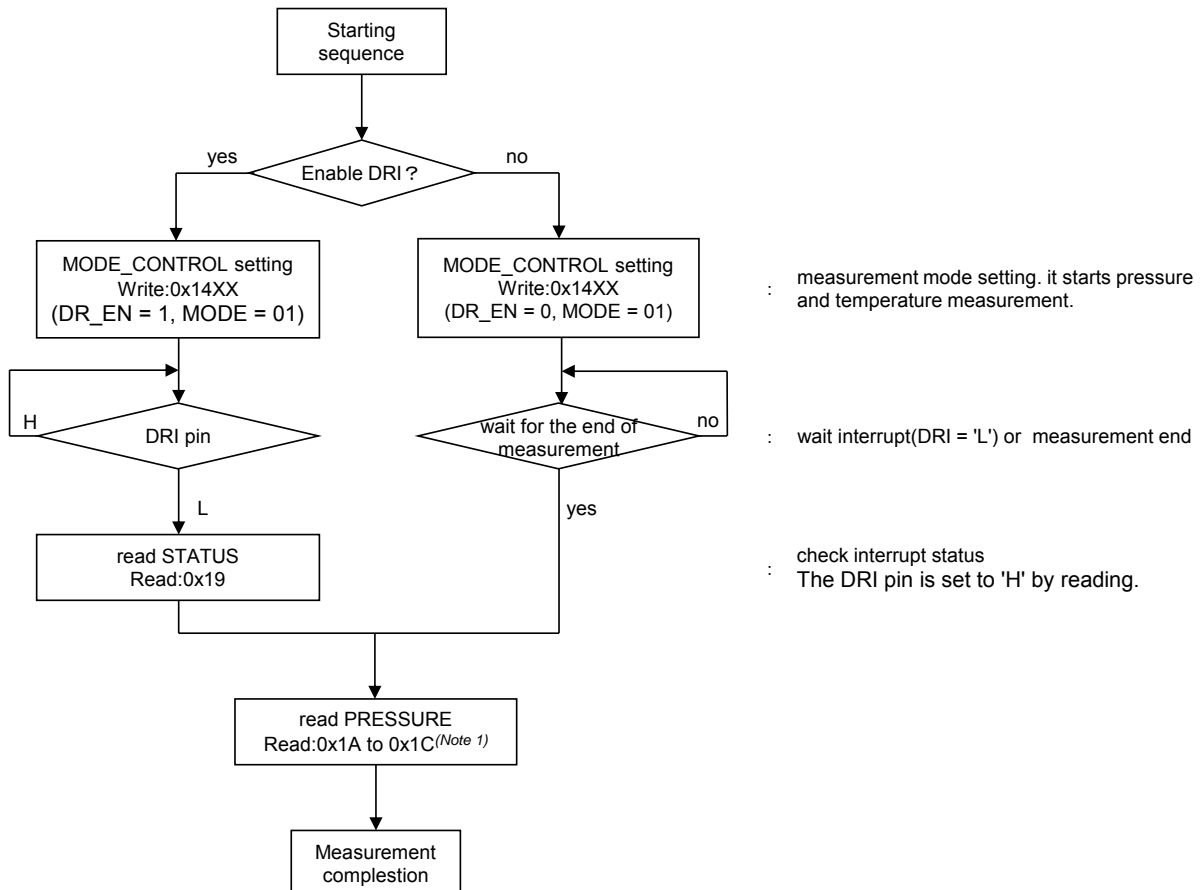

(Note 1) Data registers (0x1A, 0x1B, 0x1C) should be read by burst read.

Control sequence – continued

5. Measurement sequence: Continuous Mode (25 ms/50 ms/100 ms/200 ms)

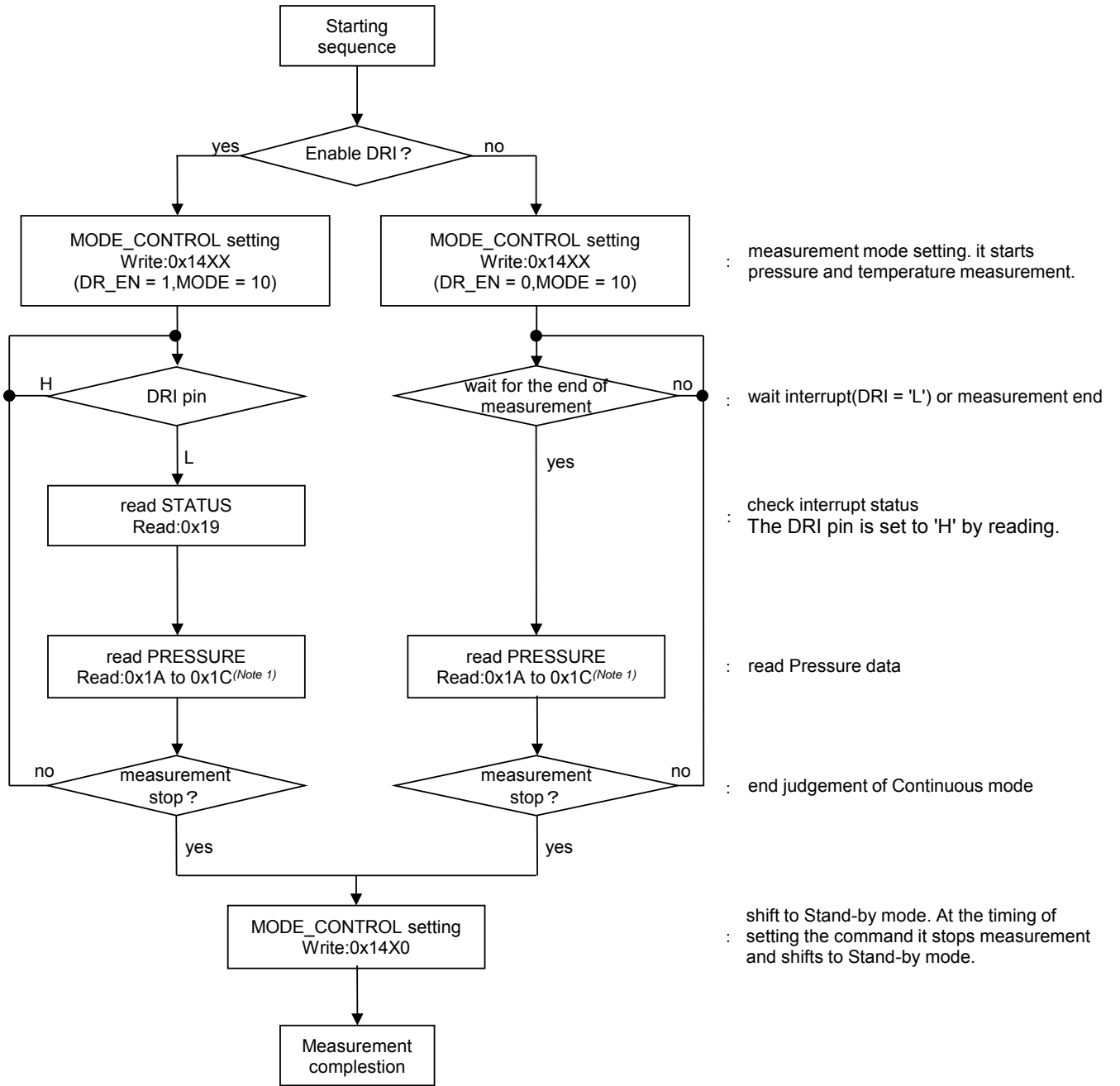

(Note 1) Data registers (0x1A, 0x1B, 0x1C) should be read by burst read.

Control sequence – continued

6. Measurement sequence: Use case of FIFO

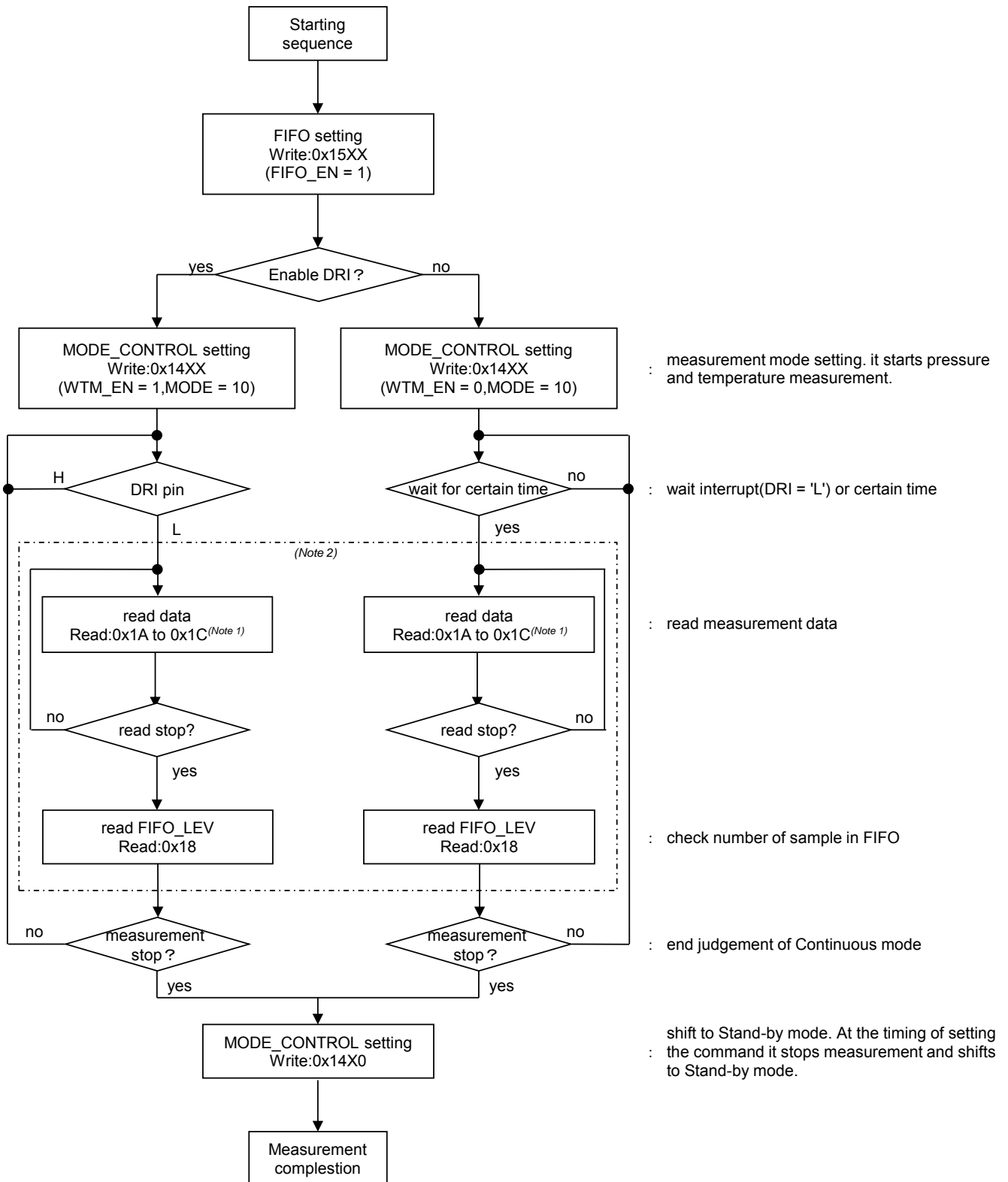

(Note 1) Data registers (0x1A, 0x1B, 0x1C) should be read by burst read.

(Note 2) During a period from a start of FIFO reading (write to address 0x1A) to FIFO\_LEV reading (write to address 0x18), do not communicate with this device. When communicating with this device during FIFO reading, read FIFO\_LEV and finish FIFO read sequence before other communication. If don't read FIFO\_LEV before other communication, there is a possibility to lose FIFO data.

Control sequence – continued

7. Ending sequence

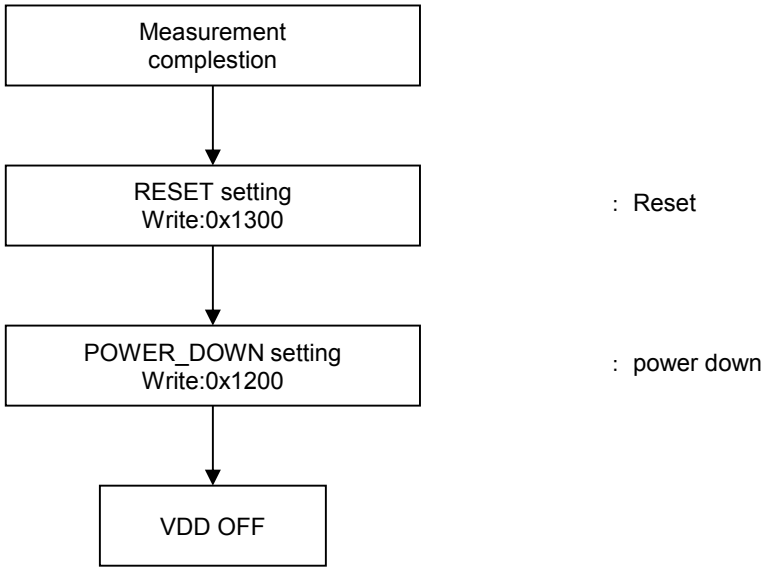

Application Example

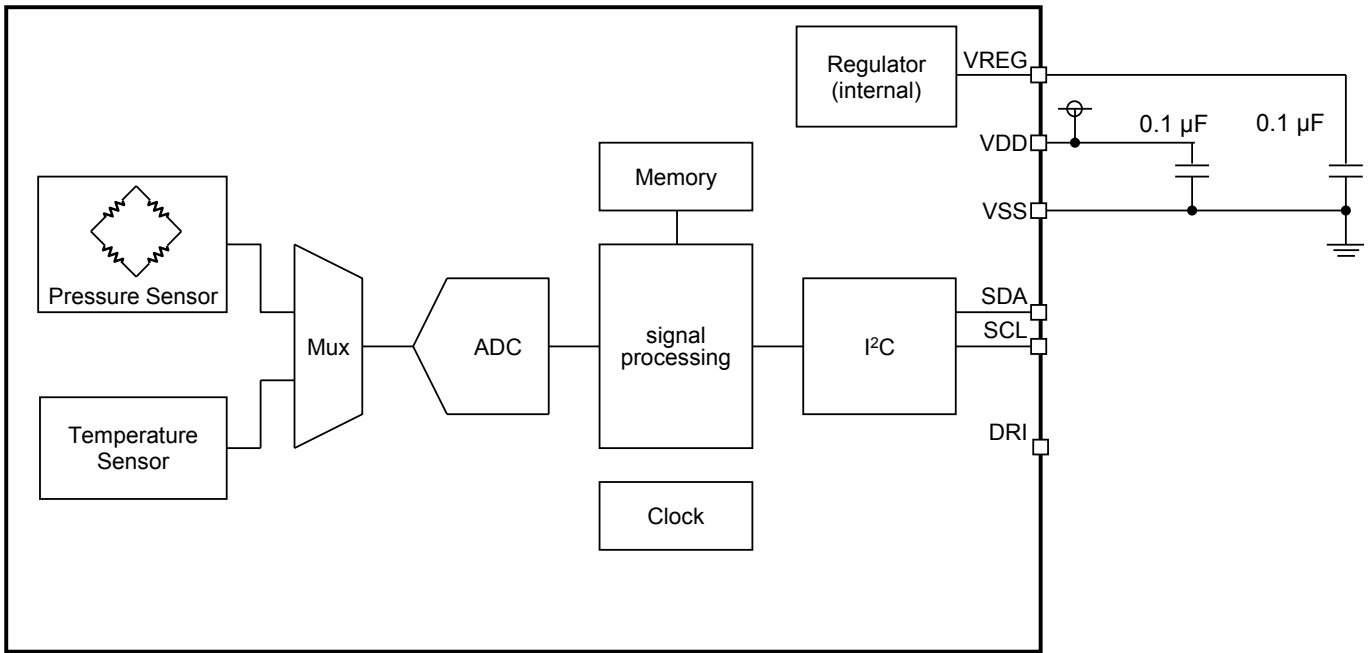

I/O Equivalent Circuits

Pin Name	Equivalent Circuit	Pin Name	Equivalent Circuit
SCL		SDA	
DRI		VREG	

## Operational Notes

### 1. Reverse Connection of Power Supply

Connecting the power supply in reverse polarity can damage the IC. Take precautions against reverse polarity when connecting the power supply, such as mounting an external diode between the power supply and the IC's power supply pins.

### 2. Power Supply Lines

Design the PCB layout pattern to provide low impedance supply lines. Furthermore, connect a capacitor to ground at all power supply pins. Consider the effect of temperature and aging on the capacitance value when using electrolytic capacitors.

### 3. Ground Voltage

Ensure that no pins are at a voltage below that of the ground pin at any time, even during transient condition.

### 4. Ground Wiring Pattern

When using both small-signal and large-current ground traces, the two ground traces should be routed separately but connected to a single ground at the reference point of the application board to avoid fluctuations in the small-signal ground caused by large currents. Also ensure that the ground traces of external components do not cause variations on the ground voltage. The ground lines must be as short and thick as possible to reduce line impedance.

### 5. Recommended Operating Conditions

The function and operation of the IC are guaranteed within the range specified by the recommended operating conditions. The characteristic values are guaranteed only under the conditions of each item specified by the electrical characteristics.

### 6. Inrush Current

When power is first supplied to the IC, it is possible that the internal logic may be unstable and inrush current may flow instantaneously due to the internal powering sequence and delays, especially if the IC has more than one power supply. Therefore, give special consideration to power coupling capacitance, power wiring, width of ground wiring, and routing of connections.

### 7. Testing on Application Boards

When testing the IC on an application board, connecting a capacitor directly to a low-impedance output pin may subject the IC to stress. Always discharge capacitors completely after each process or step. The IC's power supply should always be turned off completely before connecting or removing it from the test setup during the inspection process. To prevent damage from static discharge, ground the IC during assembly and use similar precautions during transport and storage.

### 8. Inter-pin Short and Mounting Errors

Ensure that the direction and position are correct when mounting the IC on the PCB. Incorrect mounting may result in damaging the IC. Avoid nearby pins being shorted to each other especially to ground, power supply and output pin. Inter-pin shorts could be due to many reasons such as metal particles, water droplets (in very humid environment) and unintentional solder bridge deposited in between pins during assembly to name a few.

### 9. Unused Input Pins

Input pins of an IC are often connected to the gate of a MOS transistor. The gate has extremely high impedance and extremely low capacitance. If left unconnected, the electric field from the outside can easily charge it. The small charge acquired in this way is enough to produce a significant effect on the conduction through the transistor and cause unexpected operation of the IC. So unless otherwise specified, unused input pins should be connected to the power supply or ground line.

### 10. Regarding the Input Pin of the IC

In the construction of this IC, P-N junctions are inevitably formed creating parasitic diodes or transistors. The operation of these parasitic elements can result in mutual interference among circuits, operational faults, or physical damage. Therefore, conditions which cause these parasitic elements to operate, such as applying a voltage to an input pin lower than the ground voltage should be avoided. Furthermore, do not apply a voltage to the input pins when no power supply voltage is applied to the IC. Even if the power supply voltage is applied, make sure that the input pins have voltages within the values specified in the electrical characteristics of this IC.

### 11. Ceramic Capacitor

When using a ceramic capacitor, determine a capacitance value considering the change of capacitance with temperature and the decrease in nominal capacitance due to DC bias and others.

Ordering Information

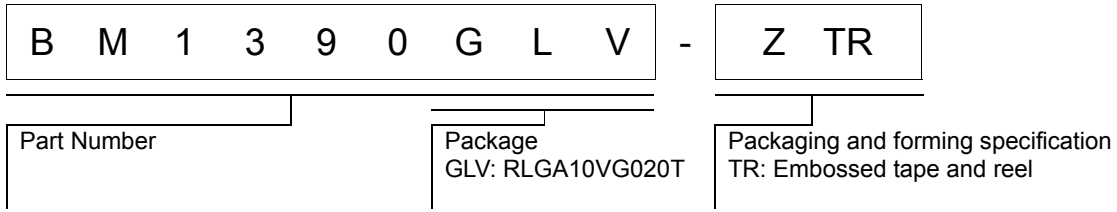

Marking Diagram

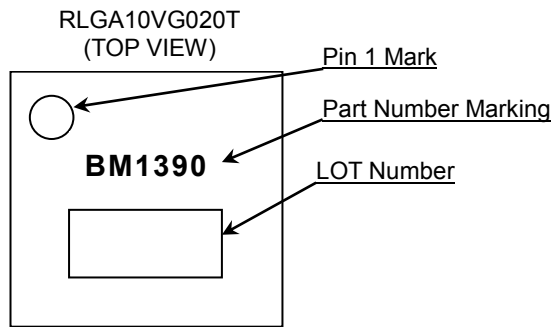

Physical Dimension and Packing Information

Package Name	RLGA10VG020T
--------------	--------------

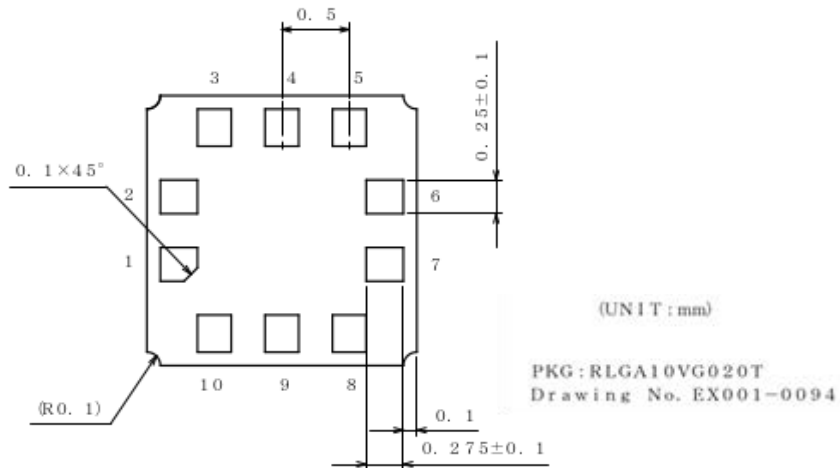
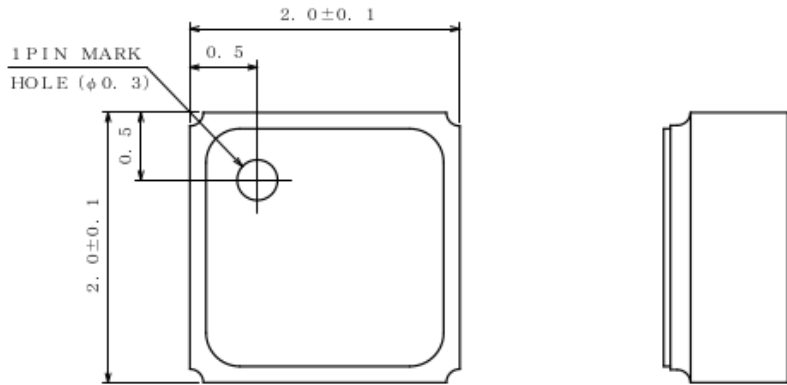

< Tape and Reel Information >

Tape	Embossed carrier tape
Quantity	3000pcs
Direction of feed	TR The direction is the pin 1 of product is at the upper right when you hold reel on the left hand and you pull out the tape on the right hand

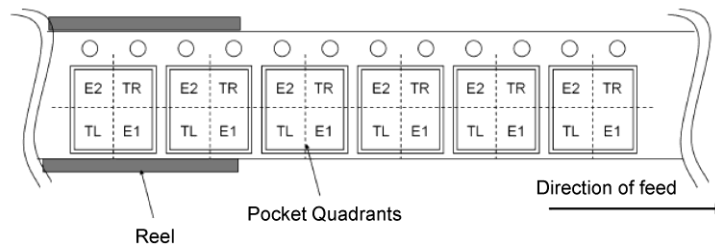

**Revision History**

Date	Revision	Changes
30.Sep.2020	001	New Release

# Notice

## Precaution on using ROHM Products

- Our Products are designed and manufactured for application in ordinary electronic equipment (such as AV equipment, OA equipment, telecommunication equipment, home electronic appliances, amusement equipment, etc.). If you intend to use our Products in devices requiring extremely high reliability (such as medical equipment <sup>(Note 1)</sup>, transport equipment, traffic equipment, aircraft/spacecraft, nuclear power controllers, fuel controllers, car equipment including car accessories, safety devices, etc.) and whose malfunction or failure may cause loss of human life, bodily injury or serious damage to property ("Specific Applications"), please consult with the ROHM sales representative in advance. Unless otherwise agreed in writing by ROHM in advance, ROHM shall not be in any way responsible or liable for any damages, expenses or losses incurred by you or third parties arising from the use of any ROHM's Products for Specific Applications.

(Note1) Medical Equipment Classification of the Specific Applications

JAPAN	USA	EU	CHINA
CLASS III	CLASS III	CLASS II b	CLASS III
CLASS IV		CLASS III	

- ROHM designs and manufactures its Products subject to strict quality control system. However, semiconductor products can fail or malfunction at a certain rate. Please be sure to implement, at your own responsibilities, adequate safety measures including but not limited to fail-safe design against the physical injury, damage to any property, which a failure or malfunction of our Products may cause. The following are examples of safety measures:
  - Installation of protection circuits or other protective devices to improve system safety
  - Installation of redundant circuits to reduce the impact of single or multiple circuit failure
- Our Products are designed and manufactured for use under standard conditions and not under any special or extraordinary environments or conditions, as exemplified below. Accordingly, ROHM shall not be in any way responsible or liable for any damages, expenses or losses arising from the use of any ROHM's Products under any special or extraordinary environments or conditions. If you intend to use our Products under any special or extraordinary environments or conditions (as exemplified below), your independent verification and confirmation of product performance, reliability, etc. prior to use, must be necessary:
  - Use of our Products in any types of liquid, including water, oils, chemicals, and organic solvents
  - Use of our Products outdoors or in places where the Products are exposed to direct sunlight or dust
  - Use of our Products in places where the Products are exposed to sea wind or corrosive gases, including Cl<sub>2</sub>, H<sub>2</sub>S, NH<sub>3</sub>, SO<sub>2</sub>, and NO<sub>2</sub>
  - Use of our Products in places where the Products are exposed to static electricity or electromagnetic waves
  - Use of our Products in proximity to heat-producing components, plastic cords, or other flammable items
  - Sealing or coating our Products with resin or other coating materials
  - Use of our Products without cleaning residue of flux (Exclude cases where no-clean type fluxes is used. However, recommend sufficiently about the residue.) ; or Washing our Products by using water or water-soluble cleaning agents for cleaning residue after soldering
  - Use of the Products in places subject to dew condensation
- The Products are not subject to radiation-proof design.
- Please verify and confirm characteristics of the final or mounted products in using the Products.
- In particular, if a transient load (a large amount of load applied in a short period of time, such as pulse, is applied, confirmation of performance characteristics after on-board mounting is strongly recommended. Avoid applying power exceeding normal rated power; exceeding the power rating under steady-state loading condition may negatively affect product performance and reliability.
- De-rate Power Dissipation depending on ambient temperature. When used in sealed area, confirm that it is the use in the range that does not exceed the maximum junction temperature.
- Confirm that operation temperature is within the specified range described in the product specification.
- ROHM shall not be in any way responsible or liable for failure induced under deviant condition from what is defined in this document.

## Precaution for Mounting / Circuit board design

- When a highly active halogenous (chlorine, bromine, etc.) flux is used, the residue of flux may negatively affect product performance and reliability.
- In principle, the reflow soldering method must be used on a surface-mount products, the flow soldering method must be used on a through hole mount products. If the flow soldering method is preferred on a surface-mount products, please consult with the ROHM representative in advance.

For details, please refer to ROHM Mounting specification

### Precautions Regarding Application Examples and External Circuits

1. If change is made to the constant of an external circuit, please allow a sufficient margin considering variations of the characteristics of the Products and external components, including transient characteristics, as well as static characteristics.
2. You agree that application notes, reference designs, and associated data and information contained in this document are presented only as guidance for Products use. Therefore, in case you use such information, you are solely responsible for it and you must exercise your own independent verification and judgment in the use of such information contained in this document. ROHM shall not be in any way responsible or liable for any damages, expenses or losses incurred by you or third parties arising from the use of such information.

### Precaution for Electrostatic

This Product is electrostatic sensitive product, which may be damaged due to electrostatic discharge. Please take proper caution in your manufacturing process and storage so that voltage exceeding the Products maximum rating will not be applied to Products. Please take special care under dry condition (e.g. Grounding of human body / equipment / solder iron, isolation from charged objects, setting of Ionizer, friction prevention and temperature / humidity control).

### Precaution for Storage / Transportation

1. Product performance and soldered connections may deteriorate if the Products are stored in the places where:
  - [a] the Products are exposed to sea winds or corrosive gases, including Cl<sub>2</sub>, H<sub>2</sub>S, NH<sub>3</sub>, SO<sub>2</sub>, and NO<sub>2</sub>
  - [b] the temperature or humidity exceeds those recommended by ROHM
  - [c] the Products are exposed to direct sunshine or condensation
  - [d] the Products are exposed to high Electrostatic
2. Even under ROHM recommended storage condition, solderability of products out of recommended storage time period may be degraded. It is strongly recommended to confirm solderability before using Products of which storage time is exceeding the recommended storage time period.
3. Store / transport cartons in the correct direction, which is indicated on a carton with a symbol. Otherwise bent leads may occur due to excessive stress applied when dropping of a carton.
4. Use Products within the specified time after opening a humidity barrier bag. Baking is required before using Products of which storage time is exceeding the recommended storage time period.

### Precaution for Product Label

A two-dimensional barcode printed on ROHM Products label is for ROHM's internal use only.

### Precaution for Disposition

When disposing Products please dispose them properly using an authorized industry waste company.

### Precaution for Foreign Exchange and Foreign Trade act

Since concerned goods might be fallen under listed items of export control prescribed by Foreign exchange and Foreign trade act, please consult with ROHM in case of export.

### Precaution Regarding Intellectual Property Rights

1. All information and data including but not limited to application example contained in this document is for reference only. ROHM does not warrant that foregoing information or data will not infringe any intellectual property rights or any other rights of any third party regarding such information or data.
2. ROHM shall not have any obligations where the claims, actions or demands arising from the combination of the Products with other articles such as components, circuits, systems or external equipment (including software).
3. No license, expressly or implied, is granted hereby under any intellectual property rights or other rights of ROHM or any third parties with respect to the Products or the information contained in this document. Provided, however, that ROHM will not assert its intellectual property rights or other rights against you or your customers to the extent necessary to manufacture or sell products containing the Products, subject to the terms and conditions herein.

### Other Precaution

1. This document may not be reprinted or reproduced, in whole or in part, without prior written consent of ROHM.
2. The Products may not be disassembled, converted, modified, reproduced or otherwise changed without prior written consent of ROHM.
3. In no event shall you use in any way whatsoever the Products and the related technical information contained in the Products or this document for any military purposes, including but not limited to, the development of mass-destruction weapons.
4. The proper names of companies or products described in this document are trademarks or registered trademarks of ROHM, its affiliated companies or third parties.

**General Precaution**







1. Before you use our Products, you are requested to carefully read this document and fully understand its contents. ROHM shall not be in any way responsible or liable for failure, malfunction or accident arising from the use of any ROHM's Products against warning, caution or note contained in this document.
2. All information contained in this document is current as of the issuing date and subject to change without any prior notice. Before purchasing or using ROHM's Products, please confirm the latest information with a ROHM sales representative.
3. The information contained in this document is provided on an "as is" basis and ROHM does not warrant that all information contained in this document is accurate and/or error-free. ROHM shall not be in any way responsible or liable for any damages, expenses or losses incurred by you or third parties resulting from inaccuracy or errors of or concerning such information.

## Looking for pricing, stock, or lifecycle information?

Click below to explore more details on WIN SOURCE:

-  [View BM1390GLV-ZTR on WIN SOURCE](#)
-  [Rohm Semiconductor](#) Information

## Optimize Your Supply Chain with WIN SOURCE Solutions

-  Global Sourcing Solution
-  Obsolete Management
-  Cost Control Management
-  Shortage Management
-  Alternative Solution
-  Excess Inventory Management