



**THE DATASHEET OF
BD63731EFV-E2**



36 V High-performance, High-reliability Withstand Voltage Stepping Motor Driver

BD63731EFV

General Description

BD63731EFV is a bipolar low-consumption driver that is driven by PWM current. Rated power supply voltage of the device is 36 V, and rated output current is 3.0 A. CLK-IN driving mode is adopted for input interface, and excitation mode is corresponding to FULL STEP mode (2 types), HALF STEP mode (2 types), QUARTER STEP mode (2 types), 1/8 STEP mode and 1/16 STEP mode via a built-in DAC. In terms of current decay, the SLOW DECAY/FAST DECAY ratio may be set without any limitation, and all available modes may be controlled in the most appropriate way. In addition, the power supply may be driven by one single system, which simplifies the design.

Features

- Rated Output Current 3.0 A
- Low ON Resistance DMOS Output
- CLK-IN Drive Mode
- PWM Constant Current (other oscillation)
- Built-in Spike Noise Cancel Function (external noise filter is unnecessary)
- FULL STEP (2 types), HALF STEP (2 types), QUARTER STEP (2 types), 1/8 STEP, 1/16 STEP Functionality
- Freely Timing Excitation Mode Switch
- Current Decay Mode Switch (linearly variable SLOW/FAST DECAY ratio)
- Normal Rotation & Reverse Rotation Switching Function
- Power Save Function
- Built-in Logic Input Pull-down Resistor
- Power-on Reset Function
- Thermal Shutdown Circuit (TSD)
- Over-current Protection Circuit (OCP)
- Under Voltage Lock Out Circuit (UVLO)
- Over Voltage Lock Out Circuit (OVLO)
- Protects Against Malfunction when Power Supply is Disconnected (Ghost Supply Prevention Function)
- Adjacent Pins Short Protection
- Microminiature, Ultra-thin and High Heat-radiation (exposed metal type) Package

Application

- Sewing Machine, PPC, Multi-function Printer, Laser Beam Printer, Ink-jet Printer, Monitoring Camera, WEB Camera, Photo Printer, FAX, Scanner, Mini Printer, Toy and Robot

Key Specifications

- Range of Power Supply Voltage 8 V to 28 V
- Rated Output Current (continuous) 3.0 A
- Rated Output Current (peak value) 3.5 A
- Range of Operating Temperature -25 °C to +85 °C
- Output ON Resistance 0.28 Ω (Typ) (total of upper and lower resistors)

Package

HTSSOP-B28

W (Typ) x D (Typ) x H (Max)
9.7 mm x 6.4 mm x 1.0 mm

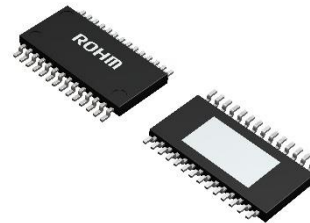

Typical Application Circuit

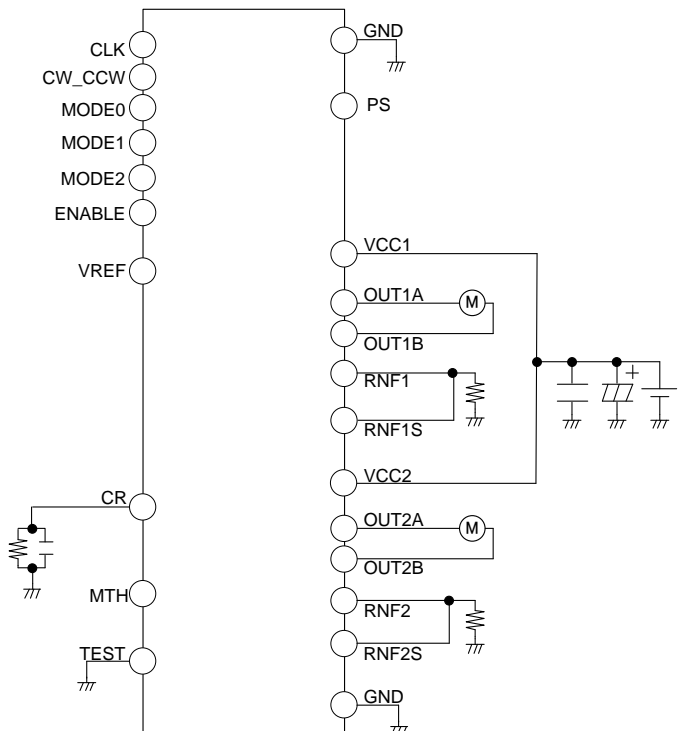

○Product structure : Silicon integrated circuit ○This product has no designed protection against radioactive rays

Pin Configuration

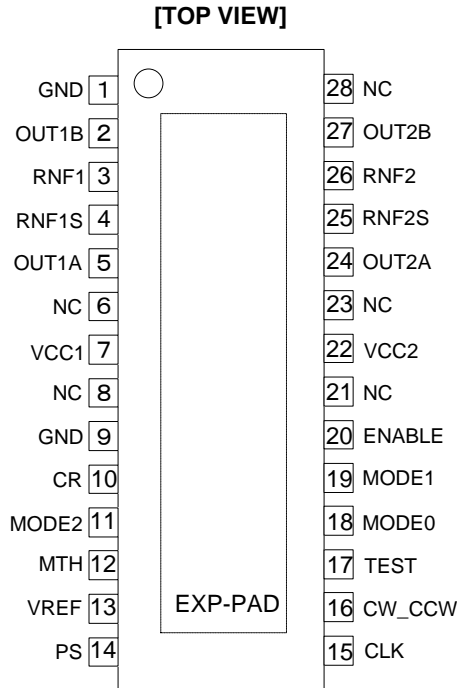

Block Diagram

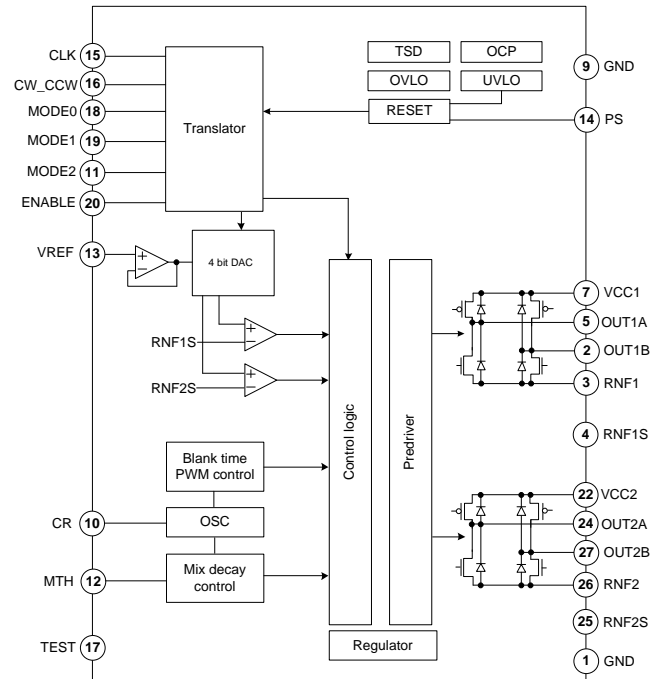

Pin Description

Pin No.	Pin Name	Function	Pin No.	Pin Name	Function
1	GND	Ground pin	15	CLK	CLK input pin for advancing the electrical angle
2	OUT1B	H bridge output pin	16	CW_CCW	Motor rotating direction setting pin
3	RNF1	Connection pin of resistor for output current detection	17	TEST	Pin for testing. (Used by connecting with GND)
4	RNF1S	Input pin of current detection comparator	18	MODE0	Motor excitation mode setting pin
5	OUT1A	H bridge output pin	19	MODE1	Motor excitation mode setting pin
6	NC	No connection	20	ENABLE	Output enable pin
7	VCC1	Power supply pin	21	NC	No connection
8	NC	No connection	22	VCC2	Power supply pin
9	GND	Ground pin	23	NC	No connection
10	CR	Connection pin of CR for setting chopping frequency	24	OUT2A	H bridge output pin
11	MODE2	Motor excitation mode setting pin	25	RNF2S	Input pin of current detection comparator
12	MTH	Current decay mode setting pin	26	RNF2	Connection pin of resistor for output current detection
13	VREF	Output current value setting pin	27	OUT2B	H bridge output pin
14	PS	Power save pin	28	NC	No connection
-	EXP-PAD	The EXP-PAD of the product connect to GND.	-	-	-

Function Explanation

1 CLK/Clock input pin for advancing the electrical angle

Trigger is CLK's rising edge. The Electrical angle advances by one for each CLK input. Motor's misstep will occur if noise is picked up at the CLK pin, so design the pattern in such a way that there is no noise plunging in.

2 MODE0, MODE1, MODE2/Motor excitation mode setting pin

Sets the motor excitation mode.

MODE0	MODE1	MODE2	Excitation Mode
L	L	L	FULL STEP A
H	L	L	HALF STEP A
L	H	L	HALF STEP B
H	H	L	QUARTER STEP A
L	L	H	FULL STEP B
H	L	H	QUARTER STEP B
L	H	H	1/8 STEP
H	H	H	1/16 STEP

Refer to the [P.15](#), [16](#), [17](#) for the timing chart and motor torque vector of various excitation modes. The excitation mode setting changes regardless of CLK signal (Refer to [P.19](#)).

3 CW_CCW/Motor rotating direction setting pin

Sets the motor's rotating direction. Change in setting is reflected at the CLK rising edge immediately after the change in setting (refer to [P.18](#)).

CW_CCW	Rotating Direction
L	Clockwise (CH2's current is outputted with a phase lag of 90° in regard to CH1's current)
H	Counter Clockwise(CH2's current is outputted with a phase lead of 90° in regard to CH1's current)

4 ENABLE/Output enable pin

Turn off forcibly all the output transistors (motor output is open). The translator circuit stop and the electrical angle doesn't advance in the section of ENABLE=L. Because CLK input is blocked.

However, during excitation modes (MODE0, MODE1, MODE2) switch within the interval of ENABLE=L, as ENABLE=L to H is reset, the new mode upon switch will be applied for excitation (Refer to [P.19](#)).

ENABLE	Motor Output
L	OPEN (electrical angle maintained)
H	ACTIVE

5 PS/Power save pin

The PS pin can make circuit in standby state and make motor output OPEN. In standby state, translator circuit is RESET (initialized) and electrical angle is initialized. When PS=L to H, be careful because there is a delay of 40 μs (Max) before it is returned from standby state to normal state and the motor output becomes ACTIVE (Refer to [P.14](#)).

PS	Status
L	Standby state (RESET)
H	ACTIVE

The electrical angle (initial electrical angle) of each excitation mode immediately after RESET is as follows (Refer to [P.15](#), [16](#), [17](#)).

Excitation Mode	Initial Electrical Angle
FULL STEP A	45°
HALF STEP A	45°
HALF STEP B	45°
QUARTER STEP A	45°
FULL STEP B	45°
QUARTER STEP B	45°
1/8 STEP	45°
1/16 STEP	45°

Function Explanation - continued**6 VCC_x^(Note 1)/Power supply pin**

Motor's drive current is flowing in this pin, design the wire in such a way that it is thick enough, as short as possible and has low impedance. VCC voltage may have large fluctuations due to counter electromotive force of the motor, PWM switching noise etc., so arrange the bypass capacitors to 100 μF to 470 μF, as close as possible to the pin and adjust in such a way the VCC voltage is stable. Increase the capacitor if needed specially when a large current is used or those motors that have large electromotive force are used. In addition, we recommend placing a multilayer ceramic capacitor of 0.01 μF to 0.1 μF in parallel for the purpose of lowering the impedance of the power supply in a wide frequency band. Extreme care should be observed to make sure that the VCC voltage does not exceed the rating even for a short period of time only. VCC_x is shorted inside the IC, so make sure to short VCC_x externally. If it is used without shorting, malfunction or destruction may occur because of concentration of current routes, so make sure to short it. In addition, the power supply in has a built-in clamp element for preventing electrostatic damage. If a steep pulse signal or voltage, such as a surge exceeding the absolute maximum rating, is applied, the clamping element may operate and be destroyed, so do not exceed the absolute maximum rating. It is also effective to attach a Zener diode of the absolute maximum rating. In addition, the diode for preventing electrostatic damage is inserted between the VCC_x pin and the GND pin, as a result there is a danger that IC will destroyed if a reverse voltage is applied, so be careful.

(Note 1) x=1 or 2

7 GND/Ground pin

In order to reduce the noise caused by switching current and stabilized the internal reference voltage of IC, wire in such a way that the wiring impedance from this pin made as low as possible to achieve the lowest electrical potential in any operating conditions. Design the pattern so that it does not have a common impedance with other GND patterns.

8 OUT1A, OUT1B, OUT2A, OUT2B/H bridge output pin

Motor's drive current is flowing in this pin, design the wire in such a way that it is thick enough, as short as possible and has low impedance. It is also effective to add a Schottky diode when the output has large positive and negative fluctuations when large current is used, for example when the back electromotive voltage is large. In addition, the output pin has a built-in clamp element for preventing electrostatic damage. If a steep pulse signal or voltage, such as a surge exceeding the absolute maximum rating, is applied, the clamping element may operate and be destroyed, so do not exceed the absolute maximum rating.

9 RNF_x^(Note 2)/Connection pin of resistor for detecting of output current

Insert current detecting resistor of 0.1 Ω to 0.2 Ω between RNF_x and GND.

The power consumption of current detecting resistor (W) can be calculated by the motor output current value (I_{OUT}) and resistance for current detecting resistor (R).

$$W = I_{OUT}^2 \times R \quad [W]$$

Where:

W : is the power consumption of current detecting resistor
 I_{OUT} : is the motor output current value
 R : is the current-detecting resistor

To avoid exceeding the rated power consumption of the resistor, consider its power consumption. In addition, design it in such a way that it has low impedance and does not have a common impedance with other GND patterns because motor's drive current flows through this pattern from the RNF_x pin to current-detecting resistor to GND. Do not exceed the rating because there is the possibility of circuits' malfunction etc., if the RNF_x voltage has exceeded the maximum rating (0.7 V). Moreover, be careful because if the RNF_x pin is shorted to GND, large current flows without normal PWM constant current control, then there is the danger that OCP or TSD will operate. If the RNF_x pin is open, then there is the possibility of such malfunction as output current does not flow either, so do not let it open.

(Note 2) x=1 or 2

10 RNF_{xS}^(Note 3)/Input pin of current detection comparator

In this IC, the RNF_{xS} pin, which is the input pin of current detection comparator, is independently arranged in order to decrease the lowering of the current-detecting accuracy caused by the wire impedance inside the IC of the RNF_x pin. Therefore, be sure to connect the RNF_x pin and the RNF_{xS} pin together when using the device in the case of PWM constant current control. In addition, impedance of board pattern between the RNF_x pin and the current-detecting resistor can decrease accuracy, so connect RNF_{xS} pattern in such a way it is connected near the current-detecting resistor so accuracy can be increased. Moreover, design the pattern in such a way that there is no noise plunging in. In addition, be careful because if the RNF_{xS} pin is shorted to GND, large current flows without normal PWM constant current control and, then there is the danger that OCP or TSD will operate.

(Note 3) x=1 or 2

Function Explanation - continued**11 VREF/Output current value setting pin**

This is the pin to set the output current value. It can be set by VREF voltage and current-detecting resistor (RNF_X ^(Note 1) resistor).
(Note 1) $x=1$ or 2

$$I_{OUT} = \frac{VREF}{5} \times \frac{1}{RNF_X} \quad [A] \dots \text{(All modes except FULL STEP B)}$$

$$I_{OUT} = \frac{VREF}{5} \times \frac{0.7071}{RNF_X} \quad [A] \dots \text{(FULL STEP B)}$$

Where:

I_{OUT} : is the output current.
 $VREF$: is the voltage of output current value-setting pin.
 RNF_X : is the current-detecting resistor.

Avoid using the VREF pin open because input becomes unsettled, and the VREF voltage increases, and then there is the possibility of such malfunctions as the setting current increases and a large current flows etc. Keep to the input voltage range because if the voltage of above 3 V is applied on the VREF pin, then there is also the danger that a large current flows in the output and so OCP or TSD will operate. Besides, take into consideration the outflow current (Max 2 μ A) if the input used is a resistor divider. The minimum current, which can be controlled by VREF voltage, is determined by motor coil's L, R values and minimum ON time because there is a minimum ON time in PWM drive.

12 CR/Connection pin of CR for setting chopping frequency

This is the pin to set the chopping frequency of output. Connect the external C (470 pF to 1500 pF) and R (10 k Ω to 200 k Ω) between this pin and GND. Refer to [P.10](#).

Make the connection from external components to GND in such a way that there is no common impedance with other GND patterns. In addition, keep the pattern away from steep pulses like square waves, etc. and there is no noise plunging in. When it is open or it is biased from the outside, it is not possible to control normal PWM constant current, so if it is used in PWM constant current control, always put both C and R parts.

13 MTH/Current decay mode setting pin

This is the pin to set the current decay mode. Current decay mode can be optionally set according to input voltage.

MTH Pin Input Voltage [V]	Current Decay Mode
0 to 0.3	SLOW DECAY
0.4 to 1.0	MIX DECAY
1.5 to 2.0	FAST DECAY
3.1 to 3.5	AUTO DECAY

Connect to GND if using at SLOW DECAY mode.

Avoid using with the MTH pin open because if the MTH pin is open, the input is unsettled, and then there is the danger that PWM operation becomes unstable. Besides, take into consideration the outflow current (Max 2 μ A) if the input used is a resistor divider.

14 TEST/Pin for testing

It is a pin to use at the time of an IC shipment test. Use it in GND connection.
In addition, malfunctions may be caused by application without grounding.

15 NC/No connection

This pin is unconnected electrically with IC internal circuit.

16 IC Back Metal

The HTSSOP-B28 package has a metal for heat dissipation on the back of the IC. Since it is assumed to be used by applying heat dissipation treatment to this metal, always GND on the substrate connect with the plane and solder, and use the GND pattern widely to ensure sufficient heat dissipation area. In addition, the backside metal is short and the back of the IC chip, so it has become a GND potential. Because there is a possibility of malfunction and destruction when it is short and the potential other than GND, never pass the wiring pattern other than GND on the back of the IC.

Protection Circuits

1 Thermal Shutdown (TSD)

This IC has a built-in thermal shutdown circuit for thermal protection. When the IC's chip temperature rises 175 °C (Typ) or more, the motor output becomes OPEN. Also, when the temperature returns to 150 °C (Typ) or less, it automatically returns to normal operation. However, even when TSD is in operation, if heat is continued to be added externally, heat overdrive can lead to destruction.

2 Over Current Protection (OCP)

This IC has a built-in over current protection circuit as a provision against destruction when the motor outputs are shorted each other or VCC-motor output or motor output-GND is shorted. This circuit latches the motor output to OPEN condition when the regulated current flows for 4 μs (Typ). It returns with power reactivation or a reset by the PS pin. The over current protection circuit's only aim is to prevent the destruction of the IC from irregular situations such as motor output shorts, and is not meant to be used as protection or security for the set. Therefore, sets should not be designed to take into account this circuit's functions. After OCP operating, if irregular situations continue and the return by power reactivation or a reset by the PS pin, then OCP operates repeatedly and the IC may generate heat or otherwise deteriorate. When the L value of the wiring is great due to the wiring being long, the motor outputs are shorted each other or VCC-motor output or motor output-GND is shorted., if the output pin voltage jumps up and the absolute maximum values can be exceeded after the over current has flowed, there is a possibility of destruction. Also, when current which is the output current rating or more and the OCP detection current or less flows, the IC can heat up to Tjmax=150 °C exceeds and can deteriorate, so current which or more the output rating should not be applied.

3 Under Voltage Lock Out (UVLO)

This IC has a built-in under voltage lock out function to prevent false operation such as IC output during power supply under voltage is low. When the applied voltage to the VCC_x pin goes 5 V (Typ) or less, the motor output is set to OPEN. This switching voltage has a 1 V (Typ) hysteresis to prevent false operation by noise etc. Be aware that this circuit does not operate during power save mode. Also, the electrical angle is reset when the UVLO circuit operates.

4 Over Voltage Lock Out (OVLO)

This IC has a built-in over voltage lock out function to protect the IC output and the motor during power supply over voltage. When the applied voltage to the VCC_x pin goes 32 V (Typ) or more, the motor output is set to OPEN. This switching voltage has a 1 V (Typ) hysteresis and a 4 μs (Typ) mask time to prevent false operation by noise etc. Although this over voltage locked out circuit is built-in, there is a possibility of destruction if the absolute maximum value for power supply voltage is exceeded. Therefore, the absolute maximum value should not be exceeded. Be aware that this circuit does not operate during power save mode.

5 Protects against malfunction when power supply is disconnected (Ghost Supply Prevention Function)

If a control signal^(Note1) is input when there is no power supplied to this IC, there is a function which prevents a malfunction where voltage is supplied to power supply of this IC or other IC in the set via the electrostatic destruction prevention diode from these input pins to the VCC_x. Therefore, there is no malfunction of the circuit even when voltage is supplied to these input pins while there is no power supply.

(Note 1) control signal=CLK, CW_CCW, MODE0, MODE1, MODE2, ENABLE, PS, MTH, VREF

6 Operation Under Strong Electromagnetic Field

The IC is not designed for using in the presence of strong electromagnetic field. Be sure to confirm that no malfunction is found when using the IC in a strong electromagnetic field.

Absolute Maximum Rating (Ta=25 °C)

Item	Symbol	Rated Value	Unit
Supply Voltage	V _{CC1} , V _{CC2}	-0.2 to +36.0	V
Input Voltage for Control Pin ^(Note 1)	V _{IN}	-0.2 to +5.5	V
RNF _x ^(Note 2) Maximum Voltage	V _{RNF}	0.7	V
Output Current	I _{OUT}	3.0 ^(Note 3)	A/Phase
Output Current (PEAK)	I _{OUTPEAK}	3.5 ^(Note 3)	A/Phase
Storage Temperature Range	T _{stg}	-55 to +150	°C
Maximum Junction Temperature	T _{jmax}	+150	°C

(Note 1) Input Voltage for Control Pin=CLK, CW_CCW, MODE0, MODE1, MODE2, ENABLE, PS, MTH, VREF

(Note 2) x=1 or 2

(Note 3) Do not exceed T_{jmax}=150 °C.

Caution 1: Operating the IC over the absolute maximum ratings may damage the IC. The damage can either be a short circuit between pins or an open circuit between pins and the internal circuitry. Therefore, it is important to consider circuit protection measures, such as adding a fuse, in case the IC is operated over the absolute maximum ratings.

Caution 2: Should by any chance the maximum junction temperature rating be exceeded the rise in temperature of the chip may result in deterioration of the properties of the chip. In case of exceeding this absolute maximum rating, design a PCB with thermal resistance taken into consideration by increasing board size and copper area so as not to exceed the maximum junction temperature rating.

Recommended Operating Condition

Item	Symbol	Min	Typ	Max	Unit
Supply Voltage	V _{CC1} , V _{CC2}	8	24	28	V
Operating Temperature	T _{opr}	-25	+25	+85	°C
Maximum Output Current (DC)	I _{OUT}	-	-	2.4 ^(Note 4)	A/Phase

(Note 4) Do not exceed T_{jmax}=150 °C.

Thermal Resistance (Note 5)

Parameter	Symbol	Thermal Resistance (Typ)		Unit
		1s ^(Note 7)	2s2p ^(Note 8)	
HTSSOP-B28				
Junction to Ambient	θ_{JA}	107.0	25.1	°C/W
Junction to Top Characterization Parameter ^(Note 6)	Ψ_{JT}	6	3	°C/W

(Note 5) Based on JESD51-2A (Still-Air).

(Note 6) The thermal characterization parameter to report the difference between junction temperature and the temperature at the top center of the outside surface of the component package.

(Note 7) Using a PCB board based on JESD51-3.

(Note 8) Using a PCB board based on JESD51-5, 7.

Layer Number of Measurement Board	Material	Board Size
Single	FR-4	114.3 mm x 76.2 mm x 1.57 mmt

Top	
Copper Pattern	Thickness
Footprints and Traces	70 μ m

Layer Number of Measurement Board	Material	Board Size	Thermal Via ^(Note 9)	
			Pitch	Diameter
4 Layers	FR-4	114.3 mm x 76.2 mm x 1.6 mmt	1.20 mm	Φ 0.30 mm

Top		2 Internal Layers		Bottom	
Copper Pattern	Thickness	Copper Pattern	Thickness	Copper Pattern	Thickness
Footprints and Traces	70 μ m	74.2 mm x 74.2 mm	35 μ m	74.2 mm x 74.2 mm	70 μ m

(Note 9) This thermal via connects with the copper pattern of all layers.

Electrical Characteristics (Unless otherwise specified Ta=25 °C, V_{CC1}=V_{CC2}=24 V)

Item	Symbol	Specification			Unit	Condition
		Min	Typ	Max		
[Whole]						
Circuit Current at Standby	I _{CCST}	-	0	10	μA	PS=L
Circuit Current	I _{CC}	-	2.0	5.0	mA	PS=H, VREF=3 V
[Control Logic Input^(Note 1)]						
H-level Input Voltage	V _{INH}	2.0	-	-	V	
L-level Input Voltage	V _{INL}	-	-	0.8	V	
H-level Input Current	I _{INH}	35	50	100	μA	V _{IN} =5 V
L-level Input Current	I _{INL}	-10	0	-	μA	V _{IN} =0 V
[Output^(Note 2)]						
Output ON Resistance	R _{ON}	-	0.280	0.392	Ω	I _{OUT} =±2.5 A (Sum of upper and lower)
Output Leak Current	I _{LEAK}	-	-	10	μA	
[Current Control]						
RNF _{xS} ^(Note 3) Input Current	I _{RNFS}	-2.0	-0.1	-	μA	RNF _{xS} =0 V
RNF _x ^(Note 3) Input Current	I _{RNF}	-80	-40	-	μA	RNF _x =0 V
VREF Input Current	I _{VREF}	-2.0	-0.1	-	μA	VREF=0 V
VREF Input Voltage Range	V _{VREF}	0	-	3.0	V	
MTH H Input Current	I _{MTH_H}	35	50	100	μA	MTH=5 V
MTH L Input Current	I _{MTH_L}	-2.0	-0.1	-	μA	MTH=0 V
MTH Input Voltage Range	V _{MTH}	0	-	3.5	V	
Minimum ON Time (Cancel time)	t _{ONMIN}	0.3	0.7	1.5	μs	C=1000 pF, R=39 kΩ
Comparator Threshold	V _{CTH}	0.579	0.600	0.621	V	VREF=3 V

(Note 1) Control Logic Input=CLK, CW_CCW, MODE0, MODE1, MODE2, ENABLE, PS

(Note 2) Output=OUT1A, OUT1B, OUT2A, OUT2B

(Note 3) x=1 or 2

PWM Constant Current Control

1 Current control operation

When the output transistor is turned on, the output current increases. The output current is converted to voltage due to the connected external resistance to the RNF_x^(Note 1) pin. When the voltage on the RNF_x pin reaches the voltage value set by the VREF input voltage, the current limit comparator operates and enters current decay mode. Output turns on again after changing this pin to the high voltage from the low voltage. The process repeats itself with chopping period (t_{CHOP}).
 (Note 1) x=1 or 2

2 Noise-masking function

In order to avoid misdetection of current detection comparator due to RNF spike noise that may occur when the output turns ON, the IC has the minimum ON time t_{ONMIN} (Blank time). The current detection is invalid from the output transistor turned on to t_{ONMIN}. This allows for constant-current drive without the need for an external filter.

3 CR Timer

The external capacitor and resistor connected to the CR pin is repeatedly charged and discharged between the V_{CRH} and V_{CRL} levels. The CR pin voltage decides in IC and it is V_{CRL}=0.4 V, V_{CRH}=1.0 V respectively. The output of the current detection comparator is masked while charging from V_{CRL} to V_{CRH}. As mentioned above, this period defines the minimum ON-time. The CR pin begins discharging once the voltage reaches V_{CRH}. When the output current reaches the current limit during this period, then the IC enters decay mode. The CR continues to discharge during this period until it reaches V_{CRL}, at which point the IC output is switched back ON. The current output and the CR pin begin charging simultaneously. The CR charge time (t_{ONMIN}) and discharge time (t_{DISCHARGE}) are set by external components, according to the following formulas. The total of t_{ONMIN} and t_{DISCHARGE} yield the chopping period, t_{CHOP}.

$$t_{ONMIN} \cong C \times \frac{R' \times R}{R' + R} \times \ln \left(\frac{V_{CR} - 0.4}{V_{CR} - 1.0} \right) \quad [s]$$

Where:

- t_{ONMIN} : is the minimum ON-time.
- C : is the capacitance of the CR Pin.
- R : is the resistance of the CR Pin.
- R' : is the CR Pin internal impedance 5 kΩ(Typ)
- V_{CR} : is the CR Pin voltage.

$$V_{CR} = V \times \frac{R}{R' + R} \quad [V]$$

Where:

- V : is the internal regulator voltage 5 V(Typ).

$$t_{DISCHARGE} \cong C \times R \times \ln \left(\frac{1 + \alpha}{0.4} \right) \quad [s]$$

Where:

- t_{DISCHARGE} : is the CR discharge time.
- α : Refer to the right graph.

$$t_{CHOP} = t_{ONMIN} + t_{DISCHARGE} \quad [s]$$

Where:

- t_{CHOP} : is the chopping period.

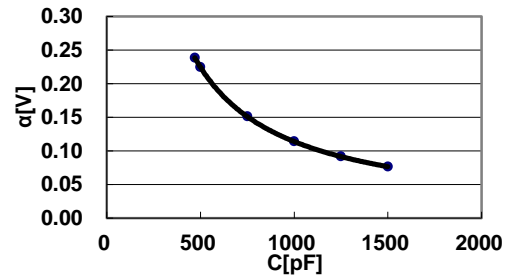
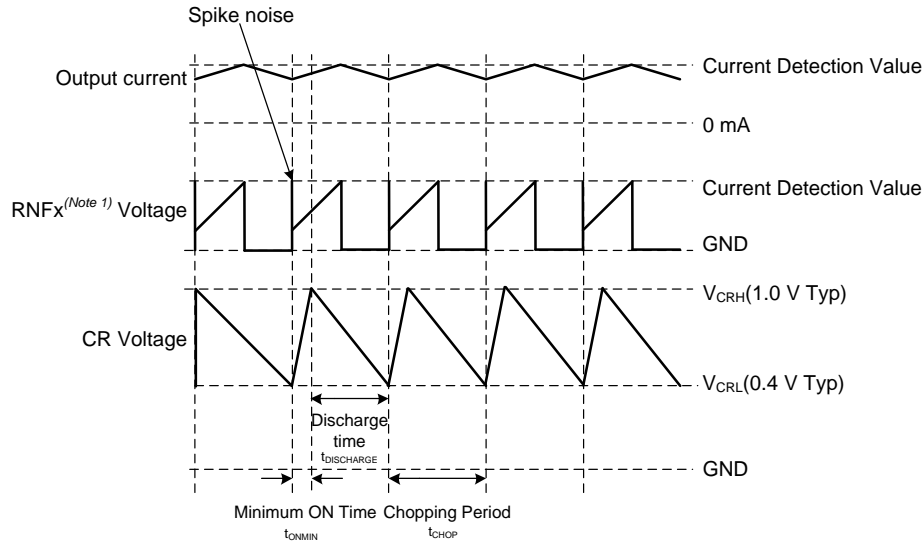

Figure 1. CR Coefficient for calculation of discharge time

3 CR Timer – continued



(Note 1) x=1 or 2

Figure 2. Timing Chart of CR Voltage, RNFx Voltage and Output Current

Attach a resistor of at least 10 kΩ to the CR Pin (10 kΩ to 200 kΩ recommended) as lower values may keep the CR from reaching the V_{CRH} voltage level. A capacitor in the range of 470 pF to 1500 pF is also recommended. Using capacitance value of several thousand pF or more, however, the noise-masking period (t_{ONMIN}) also increases, and there is a risk that the output current may exceed the setting value due to the internal L and R components of the output motor coil. Also, ensure that the chopping period (t_{CHOP}) is not set longer than necessary, as doing so will increase the output ripple, thereby decreasing the average output current and yielding lower output rotation efficiency. Select optimal value so that motor drive sound, and distortion of output current waveform can be minimized.

PWM Constant Current Control - continued

4 Current Decay Mode

PWM Constant Current Control can be optionally set the current decay mode in which the ratio of fast and slow decay. The following diagrams show the state of each transistor and the regenerative current path during the current decay for each decay mode.

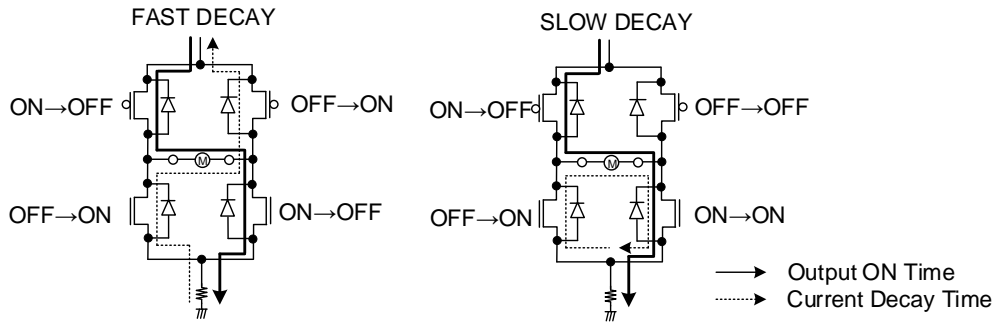

Figure 3. Route of Regenerated Current during Current Decay

The merits of each decay mode are as follows:

4.1 SLOW DECAY

The output current ripple is small and this is favorable for keeping motor torque high because the voltage between the motor coils is small and the regenerative current decreases slowly. However, an increase in the output current due to deterioration of the current control in HALF STEP, QUARTER STEP, 1/8 STEP, 1/16 STEP, due to the influence of the motor reverse electromotive voltage during high pulse rate driving in the mode, the current waveform is not able to follow the change in the current limit and the distortion and motor vibration increases. Thus, this decay mode is suited to FULL STEP mode or low-pulse-rate driven HALF STEP, QUARTER STEP, 1/8 STEP or 1/16 STEP modes.

4.2 FAST DECAY

Fast decay decreases the regeneration current much more quickly than slow decay, reducing distortion of the output current waveform. However, fast decay yields a much larger output current ripple, which decreases the overall average current running through the motor. This causes two problems: first, the motor torque decreases (increasing the current limit value can help eliminate this problem, but the rated output current must be taken into consideration); and second, the power loss within the motor increases and thereby radiates more heat. If neither of these problems is of concern, then fast decay can be used for high-pulse rate HALF STEP, QUARTER STEP, 1/8 STEP or 1/16 STEP drive.

Additionally, this IC allows for MIX DECAY mode/AUTO DECAY mode that can help to improve upon problems that arise from using fast or slow decay.

4.3 MIX DECAY

During current decay Switching between SLOW DECAY and FAST DECAY can improve current control without increasing the current ripple. In addition, the time ratio of SLOW DECAY and FAST DECAY can be changed by the voltage input to the MTH pin, and it is possible to achieve optimal control state for any motor. During MIX DECAY mode about chopping cycle, the first (t_1 to t_2) of which operates the IC in SLOW DECAY mode, and the remainder (t_2 to t_3) of which operates in FAST DECAY mode. However, if the output current does not reach the set current limit during the first (t_1 to t_2) decay period, the IC operates in fast decay mode only.

4.4 AUTO DECAY

Current control capability can still be improved without making the current ripple big by using SLOW DECAY and switches only to FAST DECAY when required. Decay mode becomes FAST DECAY only when output current reaches the set value while at minimum ON time.

MTH Pin Input Voltage [V]	Current Decay Mode
0 to 0.3	SLOW DECAY
0.4 to 1.0	MIX DECAY
1.5 to 2.0	FAST DECAY
3.1 to 3.5	AUTO DECAY

4 Current Decay Mode - continued

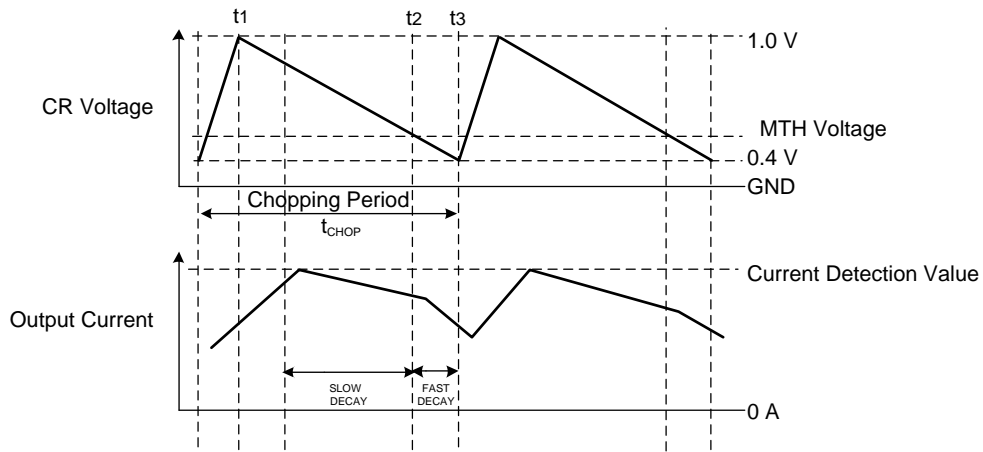

Figure 4. CR Pin Voltage and Output Current during MIX DECAy

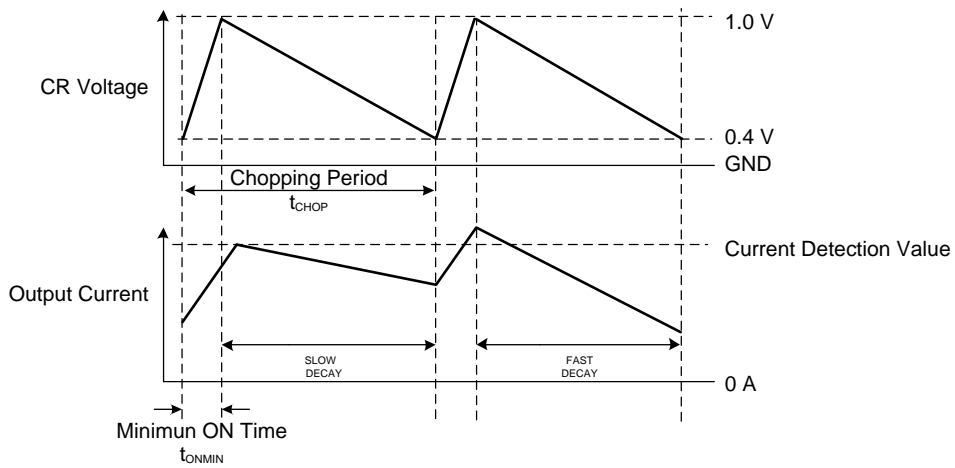

Figure 5. CR Pin Voltage and Output Current during AUTO DECAy

Translator Circuit

This series has a built in translator circuit and can drive stepping motor in CLK-IN mode. The operation of the translator circuit in CLK-IN drive mode is described as below.

1 Reset operation

The translator circuit is initialized by power ON Reset function and the PS Pin.

1.1 Initializing operation when power supply is turned on

1.1.1 If power supply is turned on at PS=L (Use this sequence as a general rule)

When power supply is turned on, the power ON reset function is initialized and operates the IC, but as long as it is PS=L, the motor output is the OPEN state. After power supply is turned on, the motor output becomes ACTIVE state by changing PS=L to H, and the excitation is started at the initial electrical angle.

But at the time of PS=L to H, it returns from the standby state to the normal state and there is a delay of 40 μs (Max) until the motor output has become the ACTIVE state.

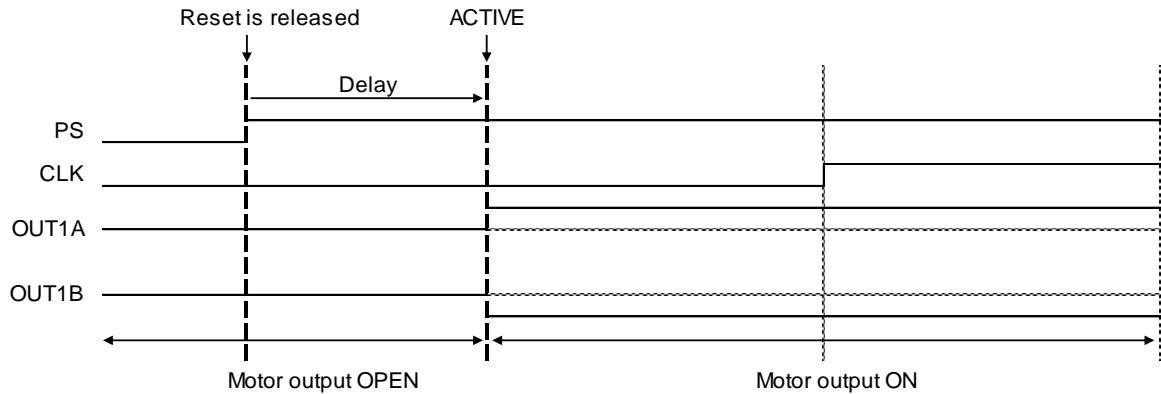

1.1.2 If power supply is turned on at PS=H

When power supply is turned on and the power ON reset function in IC operates, and be initialized before the motor output becomes the ACTIVE state during EN=H, and the excitation is started at the initial electrical angle.

1.2 Initializing operation during motor operating

Enter a reset signal to the PS pin to initialize the translator circuit during motor operation. (Refer to P.18) But at the time of PS=L to H, it returns from the standby state to the normal state and there is a delay of 40 μs (Max) until the motor output has become the ACTIVE state, so within this delay interval there is no phase advance operation even if CLK is inputted.

2 Control Input Timing

Shown below is the operation of the translator circuit at the rising edge of CLK signal. If you disobey this timing and input, then there is the possibility that the translator circuit does not operate as expected. In addition, at the time of PS=L to H, it returns from the standby state to the normal state and there is a delay of 40 μs (Max) until the motor output has become the ACTIVE state, so within this delay interval there is no phase advance operation even if CLK is inputted.

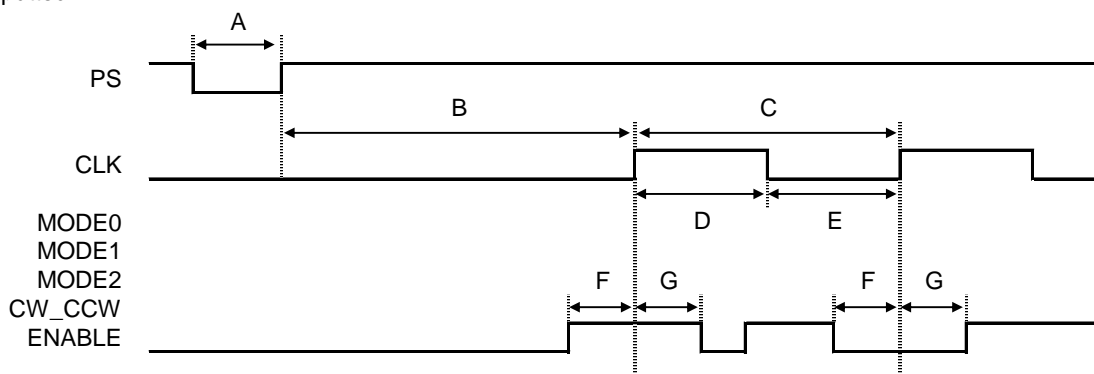

- A: PS minimum input pulse width ... 20 μs
- B: PS rising edge to CLK rising edge input possible maximum delay time ... 40 μs
- C: CLK minimum period ... 4 μs
- D: CLK minimum input H pulse width ... 2 μs
- E: CLK minimum input L pulse width ... 2 μs
- F: MODE0, MODE1, MODE2, CW_CCW, ENABLE set-up time ... 1 μs
- G: MODE0, MODE1, MODE2, CW_CCW, ENABLE hold time ... 1 μs

Translator Circuit - continued

3 FULL STEP (MODE0=L, MODE1=L, MODE2=L, CW_CCW=L, ENABLE=H)

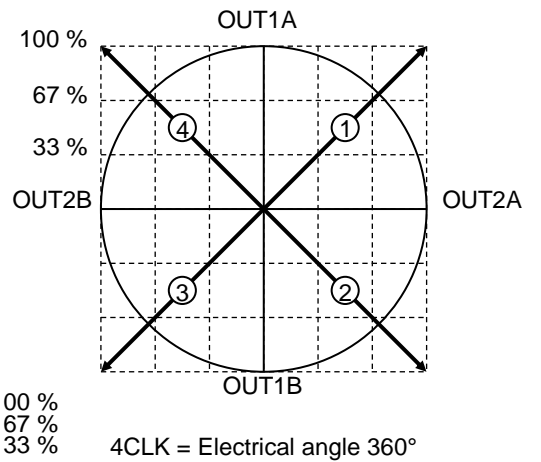
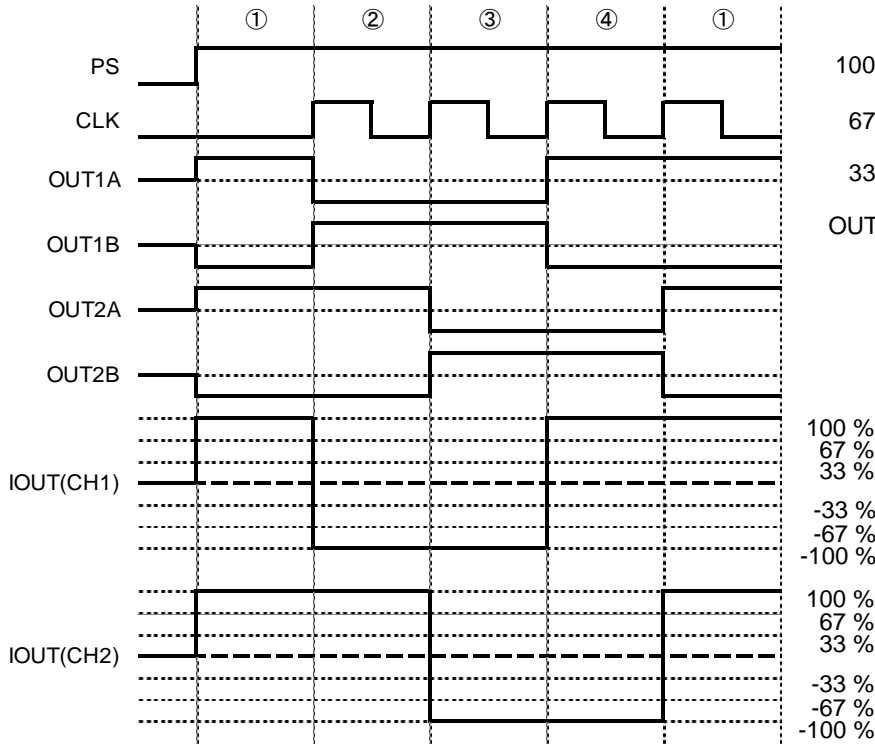

4 HALF STEP A (MODE0=H, MODE1=L, MODE2=L, CW_CCW=L, ENABLE=H)

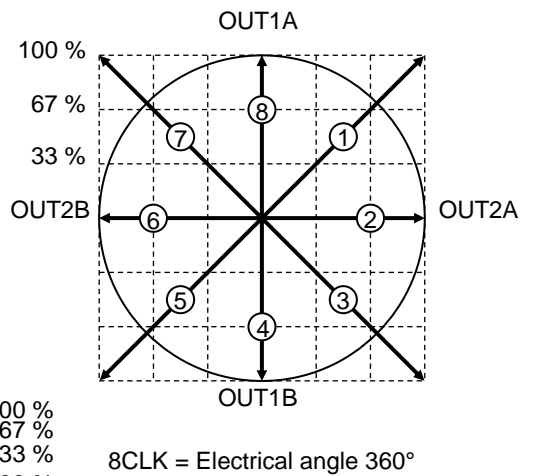
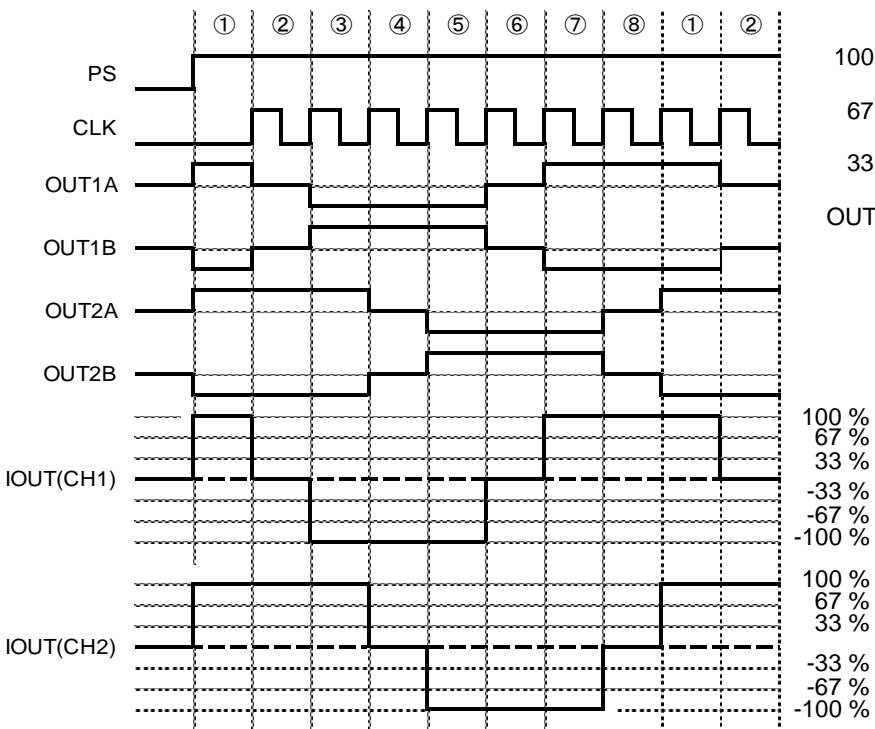

Translator Circuit - continued

5 HALF STEP B (MODE0=L, MODE1=H, MODE2=L, CW_CCW=L, ENABLE=H)

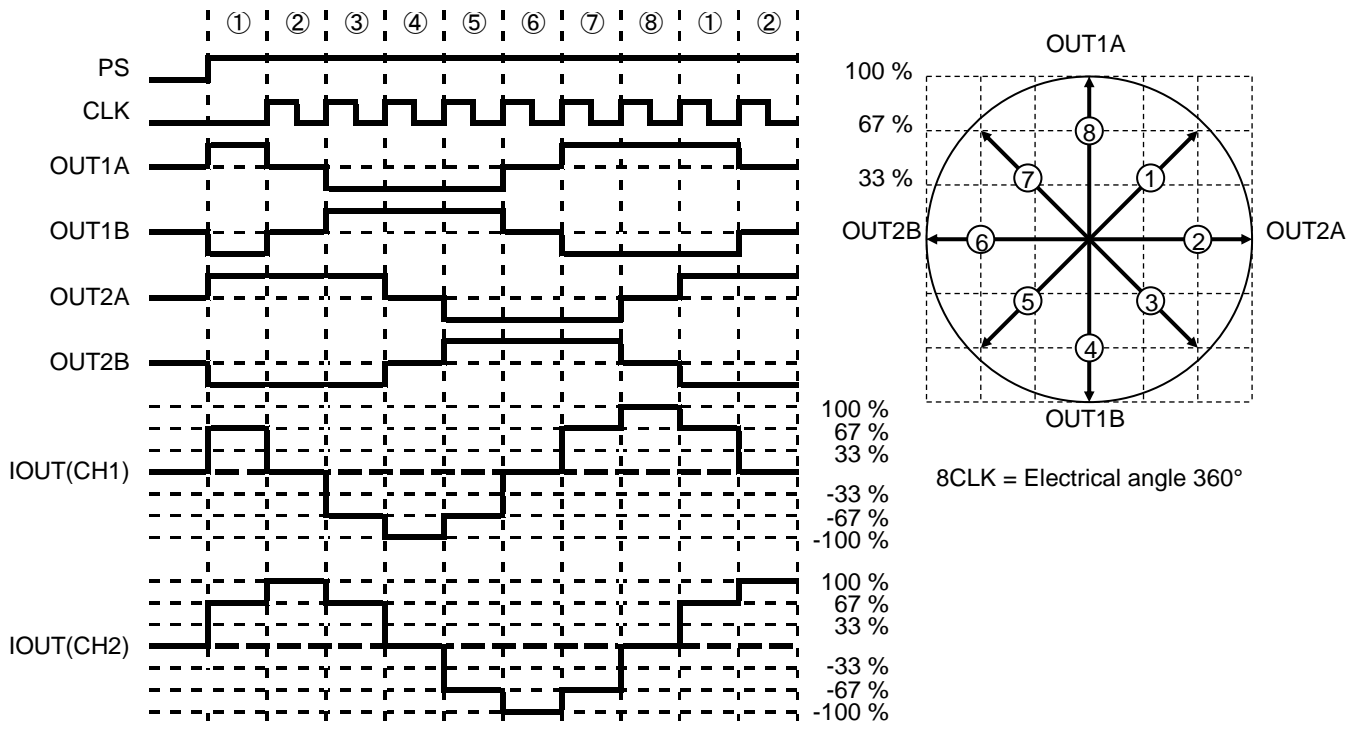

6 QUARTER STEP A (MODE0=H, MODE1=H, MODE2=L, CW_CCW=L, ENABLE=H)

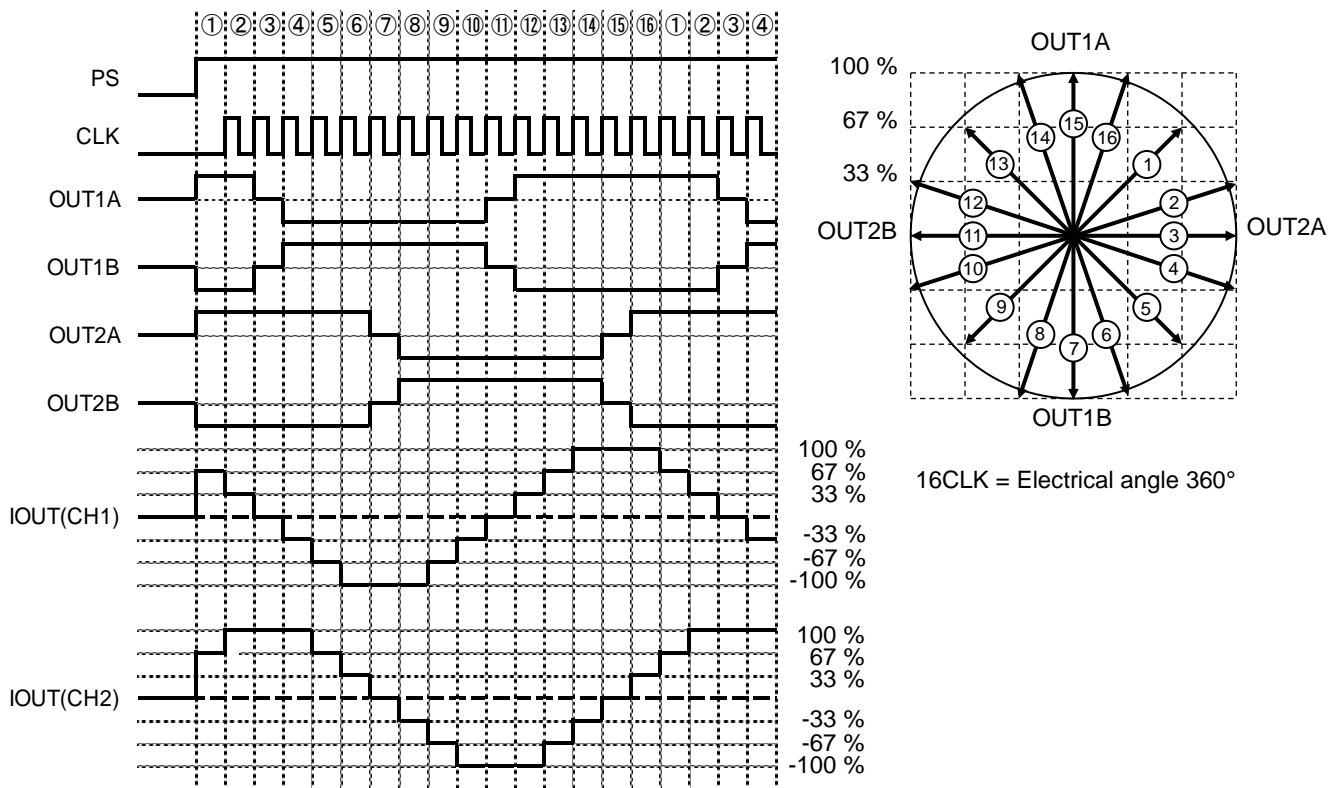

Translator Circuit - continued

7 Step sequence table (MODE2=H, CW_CCW=L, initial electrical angle = step angle 45°)

	FULL STEP B	QUARTER STEP B	1/8 STEP	1/16 STEP	CH1 CURRENT[%]	CH2 CURRENT[%]	STEP ANGLE[°]	
Initial electrical angle →		1	1	1	100.00	0.00	0.0	
				2	99.52	9.80	5.6	
			2	3	98.08	19.51	11.3	
				4	95.69	29.03	16.9	
		2	3	5	92.39	38.27	22.5	
				6	88.19	47.14	28.1	
				4	7	83.15	55.56	33.8
					8	77.30	63.44	39.4
		1	3	5	9	70.71	70.71	45.0
					10	63.44	77.30	50.6
				6	11	55.56	83.15	56.3
					12	47.14	88.19	61.9
			4	7	13	38.27	92.39	67.5
					14	29.03	95.69	73.1
				8	15	19.51	98.08	78.8
					16	9.80	99.52	84.4
			5	9	17	0.00	100.00	90.0
					18	-9.80	99.52	95.6
				10	19	-19.51	98.08	101.3
					20	-29.03	95.69	106.9
			6	11	21	-38.27	92.39	112.5
					22	-47.14	88.19	118.1
				12	23	-55.56	83.15	123.8
					24	-63.44	77.30	129.4
		2	7	13	25	-70.71	70.71	135.0
					26	-77.30	63.44	140.6
				14	27	-83.15	55.56	146.3
					28	-88.19	47.14	151.9
			8	15	29	-92.39	38.27	157.5
					30	-95.69	29.03	163.1
				16	31	-98.08	19.51	168.8
					32	-99.52	9.80	174.4
			9	17	33	-100.00	0.00	180.0
					34	-99.52	-9.80	185.6
				18	35	-98.08	-19.51	191.3
					36	-95.69	-29.03	196.9
			10	19	37	-92.39	-38.27	202.5
					38	-88.19	-47.14	208.1
				20	39	-83.15	-55.56	213.8
					40	-77.30	-63.44	219.4
		3	11	21	41	-70.71	-70.71	225.0
					42	-63.44	-77.30	230.6
				22	43	-55.56	-83.15	236.3
					44	-47.14	-88.19	241.9
			12	23	45	-38.27	-92.39	247.5
					46	-29.03	-95.69	253.1
				24	47	-19.51	-98.08	258.8
					48	-9.80	-99.52	264.4
			13	25	49	0.00	-100.00	270.0
					50	9.80	-99.52	275.6
				26	51	19.51	-98.08	281.3
					52	29.03	-95.69	286.9
			14	27	53	38.27	-92.39	292.5
					54	47.14	-88.19	298.1
				28	55	55.56	-83.15	303.8
					56	63.44	-77.30	309.4
		4	15	29	57	70.71	-70.71	315.0
					58	77.30	-63.44	320.6
				30	59	83.15	-55.56	326.3
					60	88.19	-47.14	331.9
			16	31	61	92.39	-38.27	337.5
					62	95.69	-29.03	343.1
				32	63	98.08	-19.51	348.8
					64	99.52	-9.80	354.4

Translator Circuit - continued

8 Reset Timing Chart (QUARTER STEP A, MODE0=H, MODE1=H, MODE2=L, CW_CCW=L, ENABLE=H)

To reset the translator circuit during motor operation regardless of the other input signals, enter the PS pin input to L. At this time, IC internal circuit enters the standby mode, and makes the motor output OPEN.

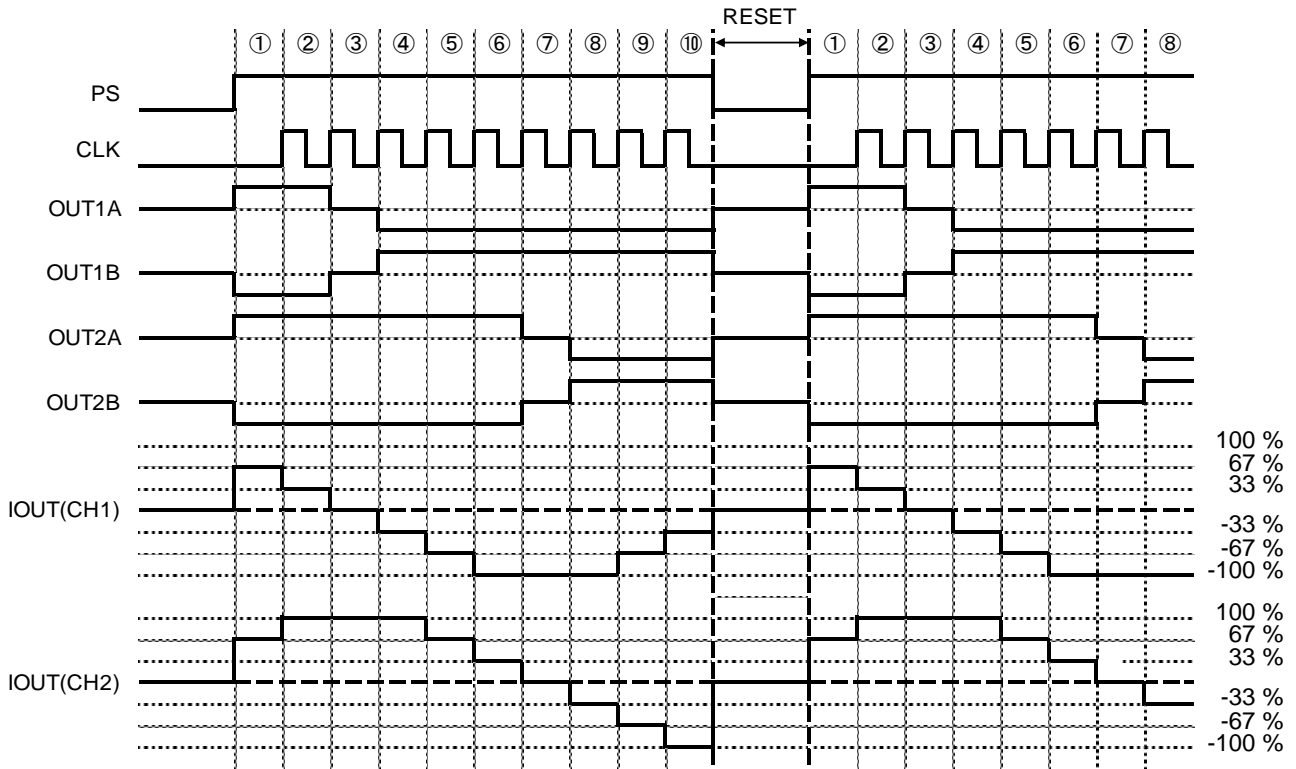

9 CW_CCW Switch Timing Chart (FULL STEP A, MODE0=L, MODE1=L, MODE2=L, ENABLE=H)

The switch of CW_CCW is reflected by the rising edge of CLK that comes immediately after CW_CCW signal has changed. However, depending on the state of operation of the motor at the time of switching, the motor cannot follow even if the control on driver IC corresponds. There are possibilities of step-out and mistake step in motor, so evaluate the sequence of the switch enough.

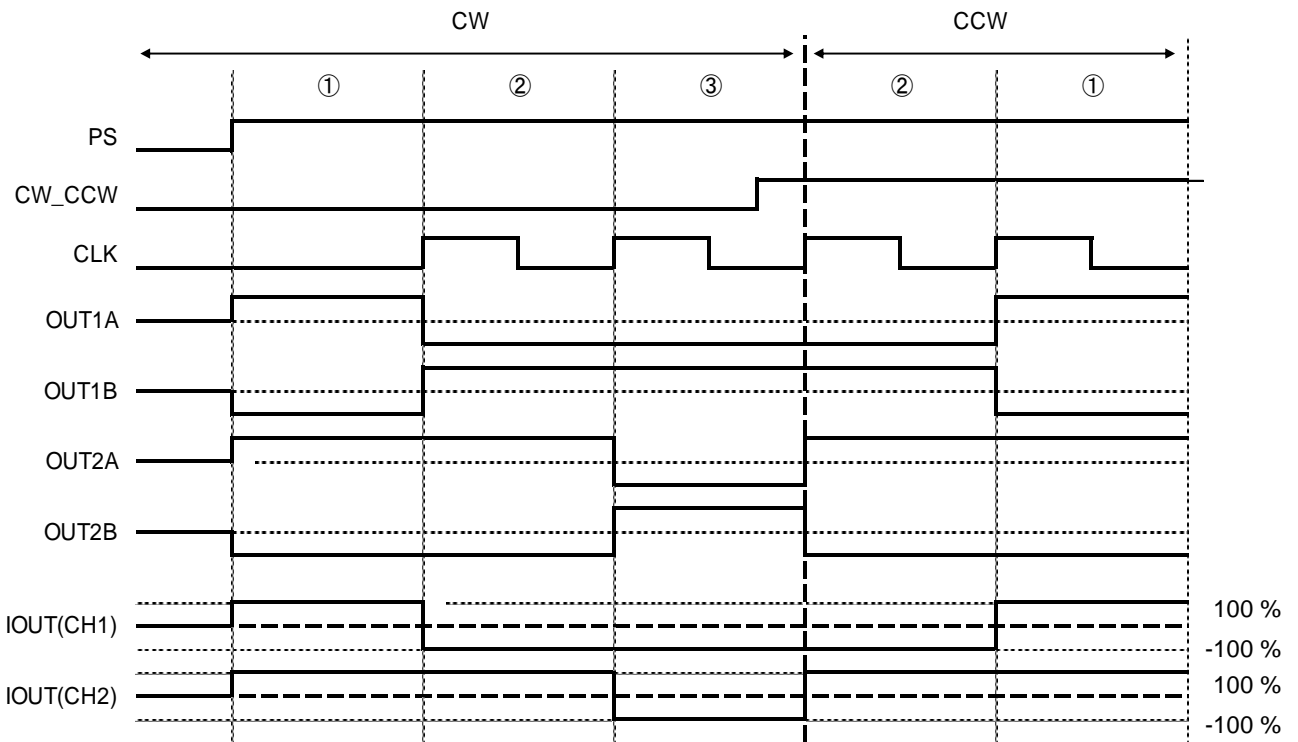

Translator Circuit - continued

10 ENABLE Switch Timing Chart (FULL STEP A, MODE0=L, MODE1=L, MODE2=L)

The switch of the ENABLE signal is reflected by the change in the ENABLE signal with regardless of other input signals.
 The translator circuit stop and the electrical angle doesn't advance in the section of ENABLE=L. Because the output for motor is OPEN and CLK input is blocked. When ENABLE=L to H, the output state returns immediately to the last state before the input of ENABLE=L. Excitation mode (MODE0, MODE1, MODE2) also switches within ENABLE=L interval. Where excitation mode switched within ENABLE=L interval, restoring of ENABLE=L to H was done in the excitation mode after switch.

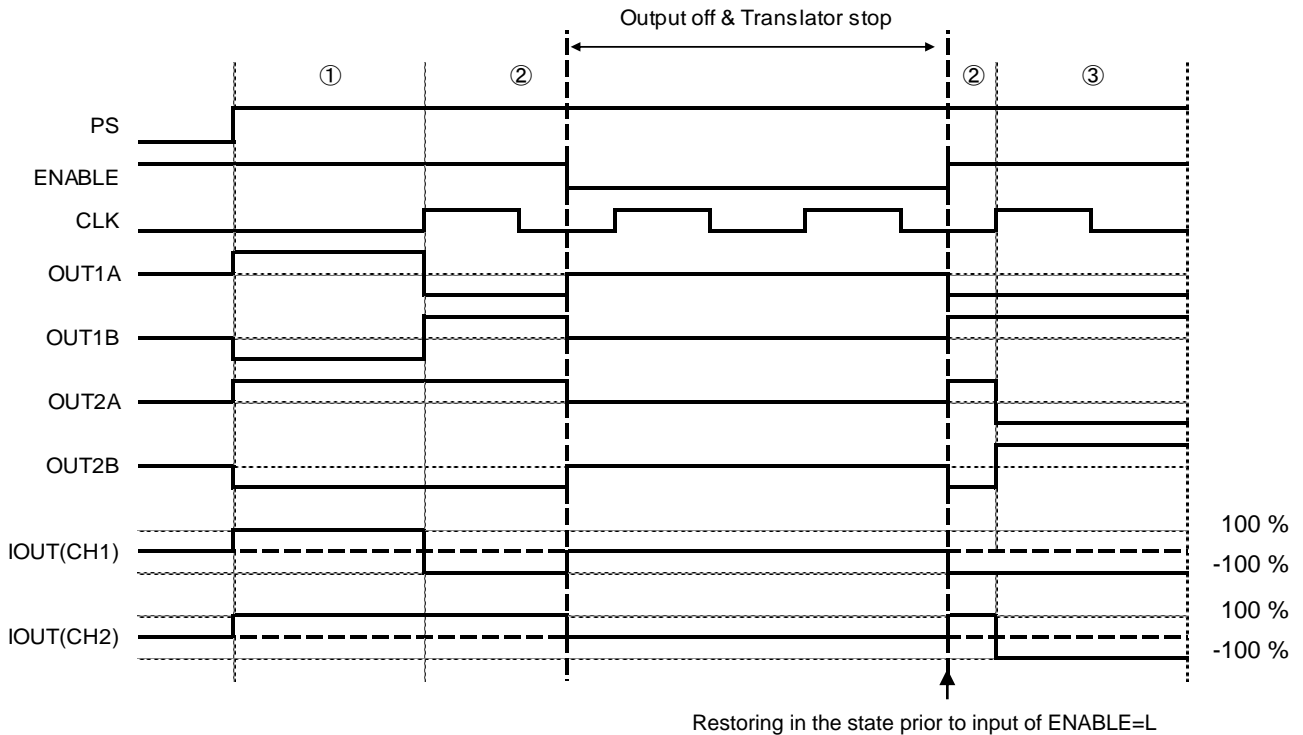

11 About the Switch of the Motor Excitation Mode

The switch of the excitation mode can be done with regardless of the CLK signal at the same time as changing of the signal MODE0, MODE1 and MODE2. The following built-in function can prevent motor out-of-step caused by discrepancies of torque vector of transitional excitations during switch between excitation modes. This function is limited to fixed MODE2 signal only. Depending on the state of operation of the motor at the switch the motor cannot follow even if the control on driver IC side is correspondent and there are possibilities of step-out and mistake step in motor. Therefore, switch sequence shall be evaluated sufficiently before any decision.

12 Cautions of Bidirectional Switch of CW_CCW and Excitation Modes (MODE0, MODE1, MODE2)

As shown in the figure below, the area between the end of reset discharge (PS=L to H) and beginning of the first CLK signal input is defined as interval A, while the area until the end of the first CLK signal input is defined as interval B.

- Interval A
=> For CW_CCW, no limitation is applied on switch of excitation mode.
- Interval B
=> In CLK1 period, or within ENABLE=L interval, CW_CCW and excitation mode can't be switched together. Violation of this restriction may lead to false step (with one extra leading phase) or out-of-step. Therefore, in case that CW_CCW and excitation modes are switched simultaneously, the PS pin must be input with reset signal. Then start to operate in interval A before carrying out such bidirectional switch.

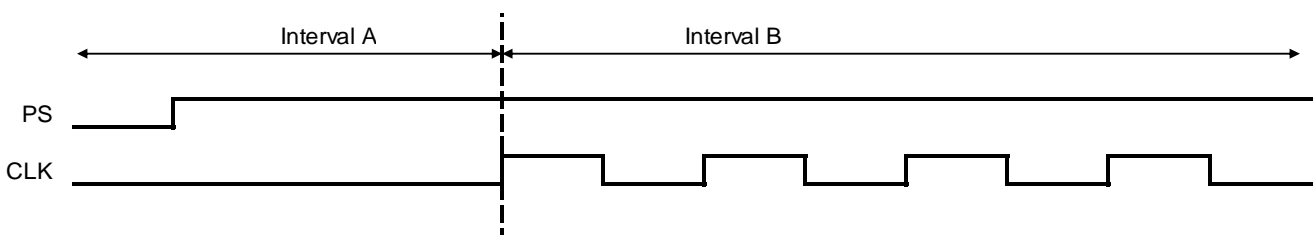

Power Dissipation

In consideration of the IC's power consumption (W), thermal resistance (°C/W), and ambient temperature (Ta), confirm that the IC's chip temperature Tj is not over 150 °C. When Tj=150 °C is exceeded, the functions as a semiconductor do not operate and problems such as parasitism and leaks occur. Constant use under these circumstances leads to deterioration and eventually destruction of the IC. Tjmax=150 °C must be strictly obeyed under all circumstances.

1 Thermal Calculation

The IC's consumed power can be estimated roughly with the power supply voltage (V_{CC}), circuit current (I_{CC}), output ON resistance (R_{ONH}, R_{ONL}) and motor output current value (I_{OUT}).

The calculation method during FULL STEP drive, SLOW DECAY mode is shown here:

$$W_{VCC} = V_{CC} \times I_{CC} \quad [W]$$

Where:

- W_{VCC} : is the consumed power of the V_{CC}.
- V_{CC} : is the power supply voltage.
- I_{CC} : is the circuit current.

$$W_{DMOS} = W_{ON} + W_{DECAY} \quad [W]$$

$$W_{ON} = (R_{ONH} + R_{ONL}) \times I_{OUT}^2 \times 2 \times on_duty \quad [W]$$

$$W_{DECAY} = (2 \times R_{ONL}) \times I_{OUT}^2 \times 2 \times (1 - on_duty) \quad [W]$$

Where:

- W_{DMOS} : is the consumed power of the output DMOS.
- W_{ON} : is the consumed power during output ON.
- W_{DECAY} : is the consumed power during current decay.
- R_{ONH} : is the upper P-channel DMOS ON-resistance.
- R_{ONL} : is the lower N-channel DMOS ON-resistance.
- I_{OUT} : is the motor output current value.
- on_duty : PWM on duty= t_{ON}/t_{CHOP}

t_{ON} varies depending on the L and R values of the motor coil and the current set value. Confirm by actual measurement, or make an approximate calculation.

t_{CHOP} is the chopping period, which depends on the CR pin. Refer to [P.10](#) for details.

IC number	Upper Pch DMOS ON Resistance R _{ONH} [Ω] (Typ)	Lower Nch DMOS ON Resistance R _{ONL} [Ω] (Typ)
BD63731EFV	0.18	0.10

$$W_{total} = W_{VCC} + W_{DMOS} \quad [W]$$

$$Tj = Ta + \theta_{ja} \times W_{total} \quad [°C]$$

Where:

- W_{total} : is the consumed total power of IC.
- Tj : is the junction temperature.
- Ta : is the ambient temperature.
- θ_{ja} : is the thermal resistance value.

However, the thermal resistance value θ_{ja} [°C/W] differs greatly depending on circuit board conditions. The calculated values above are only theoretical. For actual thermal design, perform sufficient thermal evaluation for the application board used, and create the thermal design with enough margin not to exceed Tjmax=150 °C. Although unnecessary with normal use, if the IC is used under especially strict heat conditions, consider externally attaching a Schottky diode between the motor output pin and GND to abate heat from the IC.

Power Dissipation - continued**2 Temperature Monitoring**

In respect of BD63731EFV, there is a way to directly measure the approximate chip temperature by using the TEST pin with a protection diode for prevention from electrostatic discharge. However, temperature monitor way is used only for evaluation and experimenting, and must not be used in actual usage conditions.

Process 1 Measure the pin voltage when a current of $I_{DIODE}=50\ \mu\text{A}$ flows from the TEST pin to the GND, without supplying VCC to the IC. This measurement is for measuring the V_F voltage of the internal diode.

Process 2 Measure the temperature characteristics of this pin voltage. (V_F has a linear negative temperature factor against the temperature.) With the results of these temperature characteristics, chip temperature can be calibrated from the TEST pin voltage.

Process 3 Supply VCC, confirm the TEST pin voltage while running the motor, and the chip temperature can be approximated from the results of Process 2.

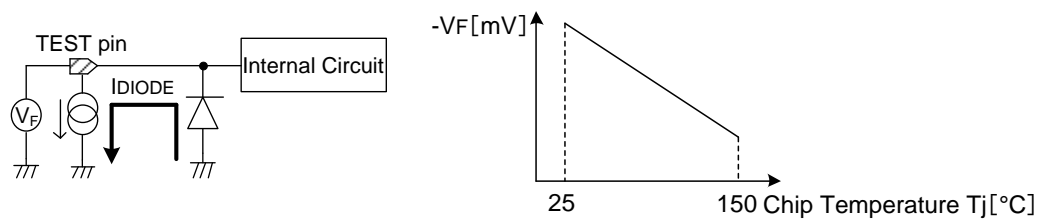
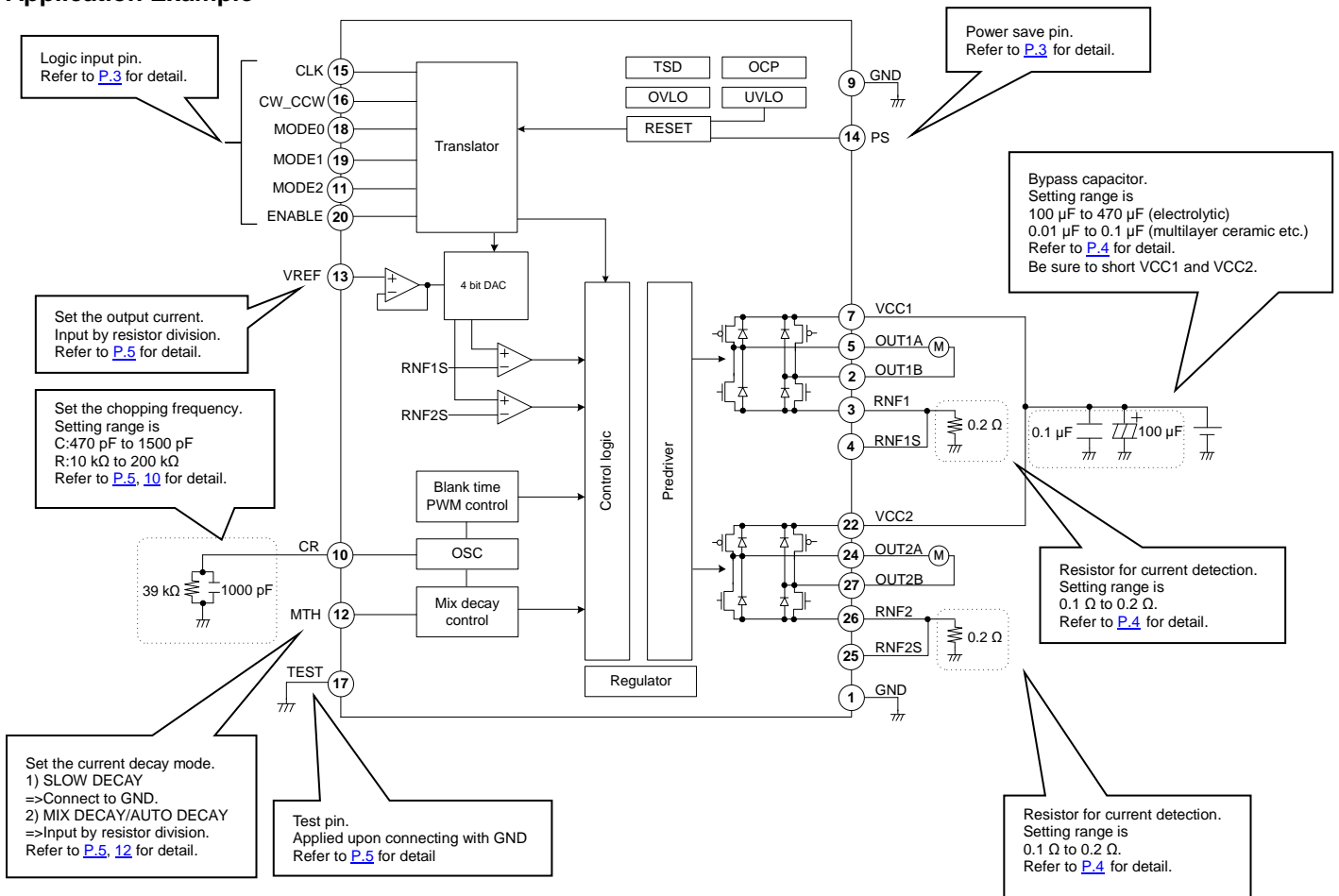
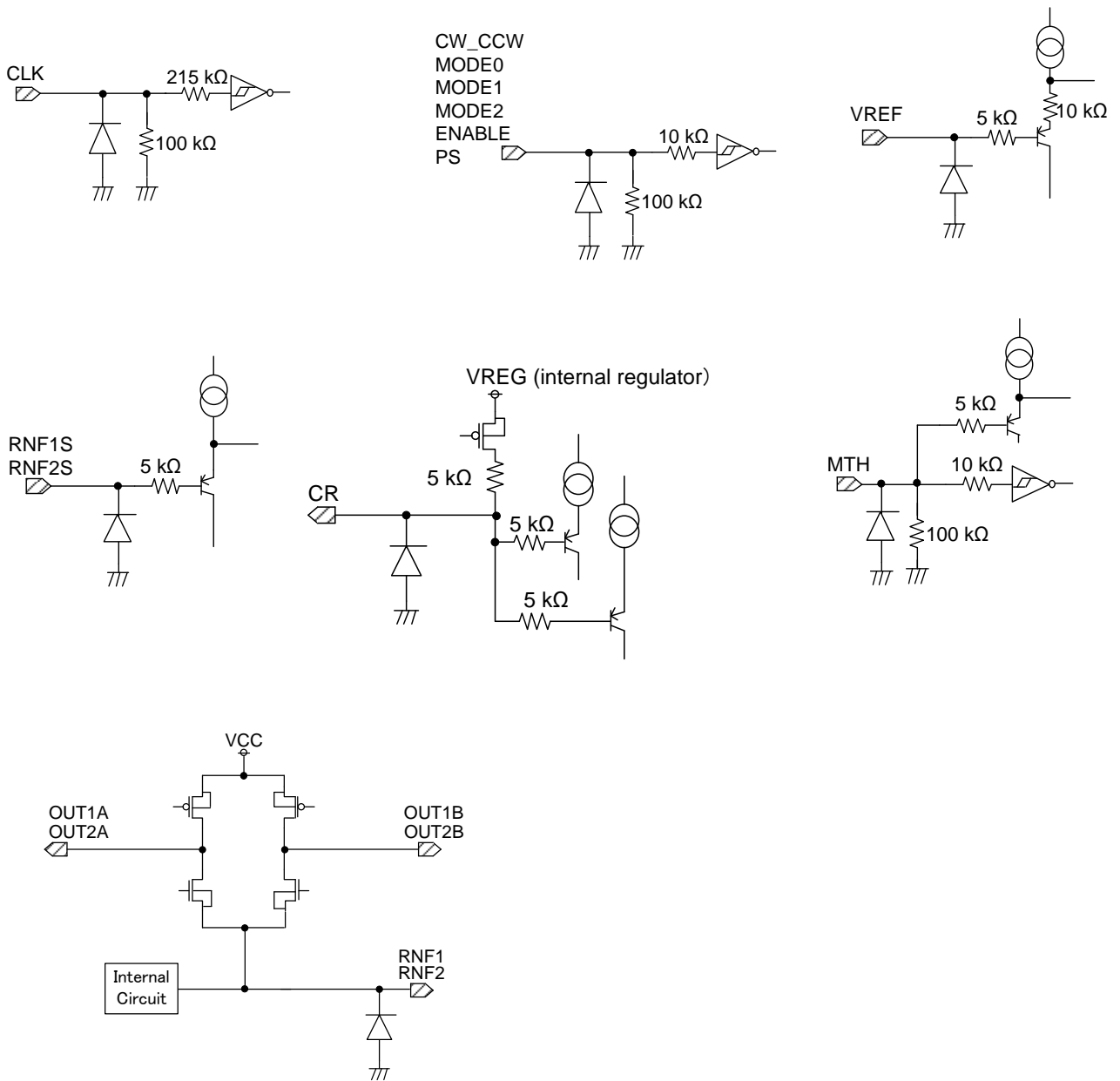

Figure 6. Model diagram for measuring chip temperature

Application Example



I/O Equivalence Circuit



Operational Notes

1 Reverse Connection of Power Supply

Connecting the power supply in reverse polarity can damage the IC. Take precautions against reverse polarity when connecting the power supply, such as mounting an external diode between the power supply and the IC's power supply pins.

2 Power Supply Lines

Design the PCB layout pattern to provide low impedance supply lines. Furthermore, connect a capacitor to ground at all power supply pins. Consider the effect of temperature and aging on the capacitance value when using electrolytic capacitors.

3 Ground Voltage

Ensure that no pins are at a voltage below that of the ground pin at any time, even during transient condition.

4 Ground Wiring Pattern

When using both small-signal and large-current ground traces, the two ground traces should be routed separately but connected to a single ground at the reference point of the application board to avoid fluctuations in the small-signal ground caused by large currents. Also ensure that the ground traces of external components do not cause variations on the ground voltage. The ground lines must be as short and thick as possible to reduce line impedance.

5 Recommended Operating Conditions

The function and operation of the IC are guaranteed within the range specified by the recommended operating conditions. The characteristic values are guaranteed only under the conditions of each item specified by the electrical characteristics.

6 Inrush Current

When power is first supplied to the IC, it is possible that the internal logic may be unstable and inrush current may flow instantaneously due to the internal powering sequence and delays, especially if the IC has more than one power supply. Therefore, give special consideration to power coupling capacitance, power wiring, width of ground wiring, and routing of connections.

7 Testing on Application Boards

When testing the IC on an application board, connecting a capacitor directly to a low-impedance output pin may subject the IC to stress. Always discharge capacitors completely after each process or step. The IC's power supply should always be turned off completely before connecting or removing it from the test setup during the inspection process. To prevent damage from static discharge, ground the IC during assembly and use similar precautions during transport and storage.

8 Inter-pin Short and Mounting Errors

Ensure that the direction and position are correct when mounting the IC on the PCB. Incorrect mounting may result in damaging the IC. Avoid nearby pins being shorted to each other especially to ground, power supply and output pin. Inter-pin shorts could be due to many reasons such as metal particles, water droplets (in very humid environment) and unintentional solder bridge deposited in between pins during assembly to name a few.

9 Unused Input Pins

Input pins of an IC are often connected to the gate of a MOS transistor. The gate has extremely high impedance and extremely low capacitance. If left unconnected, the electric field from the outside can easily charge it. The small charge acquired in this way is enough to produce a significant effect on the conduction through the transistor and cause unexpected operation of the IC. So unless otherwise specified, unused input pins should be connected to the power supply or ground line.

Operational Notes – continued

10 Regarding the Input Pin of the IC

This monolithic IC contains P+ isolation and P substrate layers between adjacent elements in order to keep them isolated. P-N junctions are formed at the intersection of the P layers with the N layers of other elements, creating a parasitic diode or transistor. For example (refer to figure below):

When $GND > Pin A$ and $GND > Pin B$, the P-N junction operates as a parasitic diode.
 When $GND > Pin B$, the P-N junction operates as a parasitic transistor.

Parasitic diodes inevitably occur in the structure of the IC. The operation of parasitic diodes can result in mutual interference among circuits, operational faults, or physical damage. Therefore, conditions that cause these diodes to operate, such as applying a voltage lower than the GND voltage to an input pin (and thus to the P substrate) should be avoided.

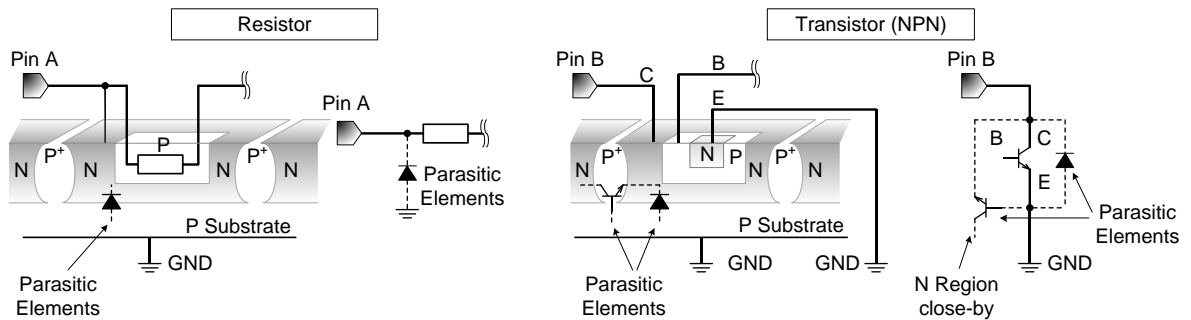

Figure 7. Example of Monolithic IC Structure

11 Ceramic Capacitor

When using a ceramic capacitor, determine a capacitance value considering the change of capacitance with temperature and the decrease in nominal capacitance due to DC bias and others.

12 Thermal Shutdown Circuit (TSD)

This IC has a built-in thermal shutdown circuit that prevents heat damage to the IC. Normal operation should always be within the IC's maximum junction temperature rating. If however the rating is exceeded for a continued period, the junction temperature (T_j) will rise which will activate the TSD circuit that will turn OFF power output pins. When the T_j falls below the TSD threshold, the circuits are automatically restored to normal operation.

Note that the TSD circuit operates in a situation that exceeds the absolute maximum ratings and therefore, under no circumstances, should the TSD circuit be used in a set design or for any purpose other than protecting the IC from heat damage.

13 Over Current Protection Circuit (OCP)

This IC incorporates an integrated overcurrent protection circuit that is activated when the load is shorted. This protection circuit is effective in preventing damage due to sudden and unexpected incidents. However, the IC should not be used in applications characterized by continuous operation or transitioning of the protection circuit.

Ordering Information

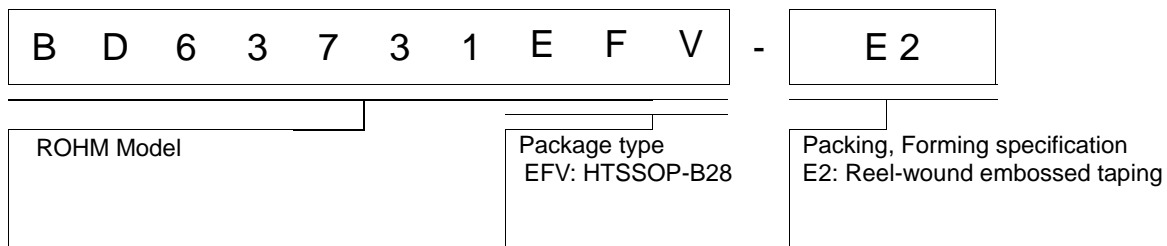

Marking Diagram

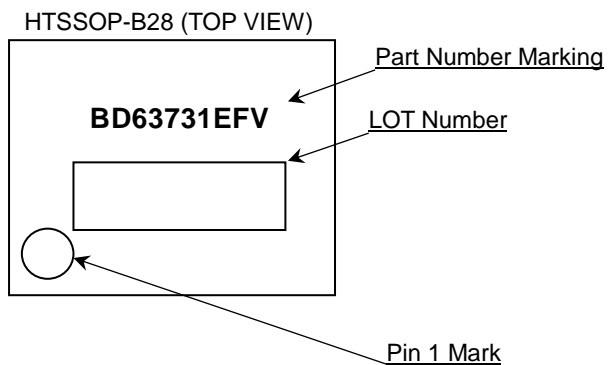

Physical Dimension and Packing Information

Package Name	HTSSOP-B28
--------------	------------

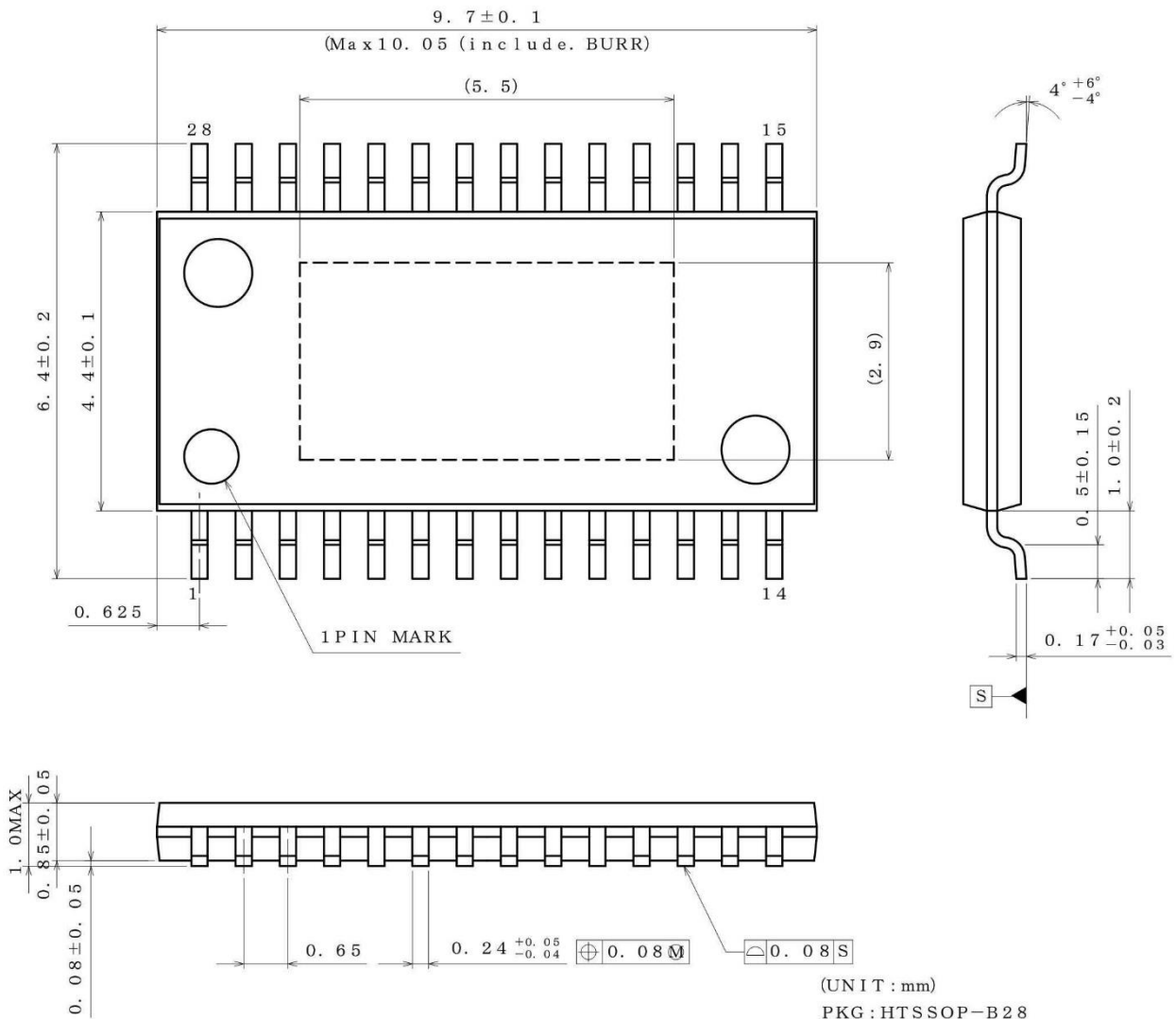

(UNIT : mm)
 PKG : HTSSOP-B28
 Drawing No. EX199-5002-1

<Tape and Reel information>

Tape	Embossed carrier tape (with dry pack)
Quantity	2500pcs
Direction of feed	E2 (The direction is the 1pin of product is at the upper left when you hold reel on the left hand and you pull out the tape on the right hand)

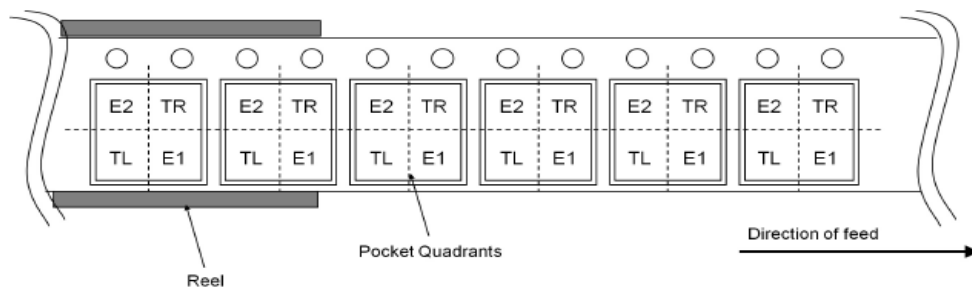

Revision History

Date	Revision	Changes
21.Jun.2019	001	New Release

Notice

Precaution on using ROHM Products

- Our Products are designed and manufactured for application in ordinary electronic equipment (such as AV equipment, OA equipment, telecommunication equipment, home electronic appliances, amusement equipment, etc.). If you intend to use our Products in devices requiring extremely high reliability (such as medical equipment ^(Note 1), transport equipment, traffic equipment, aircraft/spacecraft, nuclear power controllers, fuel controllers, car equipment including car accessories, safety devices, etc.) and whose malfunction or failure may cause loss of human life, bodily injury or serious damage to property ("Specific Applications"), please consult with the ROHM sales representative in advance. Unless otherwise agreed in writing by ROHM in advance, ROHM shall not be in any way responsible or liable for any damages, expenses or losses incurred by you or third parties arising from the use of any ROHM's Products for Specific Applications.

(Note1) Medical Equipment Classification of the Specific Applications

JAPAN	USA	EU	CHINA
CLASS III	CLASS III	CLASS II b	CLASS III
CLASS IV		CLASS III	

- ROHM designs and manufactures its Products subject to strict quality control system. However, semiconductor products can fail or malfunction at a certain rate. Please be sure to implement, at your own responsibilities, adequate safety measures including but not limited to fail-safe design against the physical injury, damage to any property, which a failure or malfunction of our Products may cause. The following are examples of safety measures:
 - Installation of protection circuits or other protective devices to improve system safety
 - Installation of redundant circuits to reduce the impact of single or multiple circuit failure
- Our Products are designed and manufactured for use under standard conditions and not under any special or extraordinary environments or conditions, as exemplified below. Accordingly, ROHM shall not be in any way responsible or liable for any damages, expenses or losses arising from the use of any ROHM's Products under any special or extraordinary environments or conditions. If you intend to use our Products under any special or extraordinary environments or conditions (as exemplified below), your independent verification and confirmation of product performance, reliability, etc. prior to use, must be necessary:
 - Use of our Products in any types of liquid, including water, oils, chemicals, and organic solvents
 - Use of our Products outdoors or in places where the Products are exposed to direct sunlight or dust
 - Use of our Products in places where the Products are exposed to sea wind or corrosive gases, including Cl₂, H₂S, NH₃, SO₂, and NO₂
 - Use of our Products in places where the Products are exposed to static electricity or electromagnetic waves
 - Use of our Products in proximity to heat-producing components, plastic cords, or other flammable items
 - Sealing or coating our Products with resin or other coating materials
 - Use of our Products without cleaning residue of flux (Exclude cases where no-clean type fluxes is used. However, recommend sufficiently about the residue.) ; or Washing our Products by using water or water-soluble cleaning agents for cleaning residue after soldering
 - Use of the Products in places subject to dew condensation
- The Products are not subject to radiation-proof design.
- Please verify and confirm characteristics of the final or mounted products in using the Products.
- In particular, if a transient load (a large amount of load applied in a short period of time, such as pulse, is applied, confirmation of performance characteristics after on-board mounting is strongly recommended. Avoid applying power exceeding normal rated power; exceeding the power rating under steady-state loading condition may negatively affect product performance and reliability.
- De-rate Power Dissipation depending on ambient temperature. When used in sealed area, confirm that it is the use in the range that does not exceed the maximum junction temperature.
- Confirm that operation temperature is within the specified range described in the product specification.
- ROHM shall not be in any way responsible or liable for failure induced under deviant condition from what is defined in this document.

Precaution for Mounting / Circuit board design

- When a highly active halogenous (chlorine, bromine, etc.) flux is used, the residue of flux may negatively affect product performance and reliability.
- In principle, the reflow soldering method must be used on a surface-mount products, the flow soldering method must be used on a through hole mount products. If the flow soldering method is preferred on a surface-mount products, please consult with the ROHM representative in advance.

For details, please refer to ROHM Mounting specification

Precautions Regarding Application Examples and External Circuits

1. If change is made to the constant of an external circuit, please allow a sufficient margin considering variations of the characteristics of the Products and external components, including transient characteristics, as well as static characteristics.
2. You agree that application notes, reference designs, and associated data and information contained in this document are presented only as guidance for Products use. Therefore, in case you use such information, you are solely responsible for it and you must exercise your own independent verification and judgment in the use of such information contained in this document. ROHM shall not be in any way responsible or liable for any damages, expenses or losses incurred by you or third parties arising from the use of such information.

Precaution for Electrostatic

This Product is electrostatic sensitive product, which may be damaged due to electrostatic discharge. Please take proper caution in your manufacturing process and storage so that voltage exceeding the Products maximum rating will not be applied to Products. Please take special care under dry condition (e.g. Grounding of human body / equipment / solder iron, isolation from charged objects, setting of Ionizer, friction prevention and temperature / humidity control).

Precaution for Storage / Transportation

1. Product performance and soldered connections may deteriorate if the Products are stored in the places where:
 - [a] the Products are exposed to sea winds or corrosive gases, including Cl₂, H₂S, NH₃, SO₂, and NO₂
 - [b] the temperature or humidity exceeds those recommended by ROHM
 - [c] the Products are exposed to direct sunshine or condensation
 - [d] the Products are exposed to high Electrostatic
2. Even under ROHM recommended storage condition, solderability of products out of recommended storage time period may be degraded. It is strongly recommended to confirm solderability before using Products of which storage time is exceeding the recommended storage time period.
3. Store / transport cartons in the correct direction, which is indicated on a carton with a symbol. Otherwise bent leads may occur due to excessive stress applied when dropping of a carton.
4. Use Products within the specified time after opening a humidity barrier bag. Baking is required before using Products of which storage time is exceeding the recommended storage time period.

Precaution for Product Label

A two-dimensional barcode printed on ROHM Products label is for ROHM's internal use only.

Precaution for Disposition

When disposing Products please dispose them properly using an authorized industry waste company.

Precaution for Foreign Exchange and Foreign Trade act

Since concerned goods might be fallen under listed items of export control prescribed by Foreign exchange and Foreign trade act, please consult with ROHM in case of export.

Precaution Regarding Intellectual Property Rights

1. All information and data including but not limited to application example contained in this document is for reference only. ROHM does not warrant that foregoing information or data will not infringe any intellectual property rights or any other rights of any third party regarding such information or data.
2. ROHM shall not have any obligations where the claims, actions or demands arising from the combination of the Products with other articles such as components, circuits, systems or external equipment (including software).
3. No license, expressly or implied, is granted hereby under any intellectual property rights or other rights of ROHM or any third parties with respect to the Products or the information contained in this document. Provided, however, that ROHM will not assert its intellectual property rights or other rights against you or your customers to the extent necessary to manufacture or sell products containing the Products, subject to the terms and conditions herein.

Other Precaution



1. This document may not be reprinted or reproduced, in whole or in part, without prior written consent of ROHM.
2. The Products may not be disassembled, converted, modified, reproduced or otherwise changed without prior written consent of ROHM.
3. In no event shall you use in any way whatsoever the Products and the related technical information contained in the Products or this document for any military purposes, including but not limited to, the development of mass-destruction weapons.
4. The proper names of companies or products described in this document are trademarks or registered trademarks of ROHM, its affiliated companies or third parties.

General Precaution





1. Before you use our Products, you are requested to carefully read this document and fully understand its contents. ROHM shall not be in any way responsible or liable for failure, malfunction or accident arising from the use of any ROHM's Products against warning, caution or note contained in this document.
2. All information contained in this document is current as of the issuing date and subject to change without any prior notice. Before purchasing or using ROHM's Products, please confirm the latest information with a ROHM sales representative.
3. The information contained in this document is provided on an "as is" basis and ROHM does not warrant that all information contained in this document is accurate and/or error-free. ROHM shall not be in any way responsible or liable for any damages, expenses or losses incurred by you or third parties resulting from inaccuracy or errors of or concerning such information.

Looking for pricing, stock, or lifecycle information?

Click below to explore more details on WIN SOURCE:

-  [View BD63731EFV-E2 on WIN SOURCE](#)
-  [Rohm Semiconductor](#) Information

Optimize Your Supply Chain with WIN SOURCE Solutions

-  Global Sourcing Solution
-  Obsolete Management
-  Cost Control Management
-  Shortage Management
-  Alternative Solution
-  Excess Inventory Management