

TPS212x 2.8-V to 22-V Priority Power MUX with Seamless Switchover

1 Features

- Wide operating range: 2.8 V to 22 V
 - Absolute maximum input voltage of 24 V
- Low RON resistance:
 - TPS2120: 62 mΩ (typical)
 - TPS2121: 56 mΩ (typical)
- Adjustable overvoltage supervisor (OVx):
 - Accuracy < ±5%
- Adjustable priority supervisor (PR1):
 - Accuracy < ±5%
- TPS2121 Supports external voltage reference (CP2) with an accuracy of <1%
- Output current limit (ILM):
 - TPS2120: 1 A – 3 A
 - TPS2121: 1 A – 4.5 A
- Channel status indication (ST)
- Adjustable input settling time (SS)
- Adjustable output soft start time (SS)
- TPS2121 Fast output switchover (t_{SW}): 5 μs (typical)
- Low Iq from enabled input: 200 μA (typical)
- Low Iq from disabled input: 10 μA (Typical)
- Manual input source selection (OVx)
- Over temperature protection (OTP)

2 Applications

- Backup and standby power
- Input source selection
- Multiple battery management
- EPOS and barcode scanners
- Building automation and surveillance
- Tracking and telematics

3 Description

The TPS212x devices are Dual-Input, Single-Output (DISO) Power Multiplexer (MUX) that are well suited for a variety of systems having multiple power sources. The devices will Automatically Detect, Select, and Seamlessly Transition between available inputs.

Priority can be automatically given to the highest input voltage or manually assigned to a lower voltage input to support both ORing and Source Selection operations. A priority voltage supervisor is used to select an input source.

An Ideal Diode operation is used to seamlessly transition between input sources. During switchover, the voltage drop is controlled to block reverse current before it happens and provide uninterrupted power to the load with minimal hold-up capacitance.

Current limiting is used during startup and switchover to protect against overcurrent events, and also protects the device during normal operation. The output current limit can be adjusted with a single external resistor.

The TPS212x devices are available in WCSP and small VQFN-HR package options characterized for operation for a temperature range of –40°C to 125°C.

Device Information

PART NUMBER	PACKAGE ⁽¹⁾	BODY SIZE (NOM)
TPS2120	WCSP (20)	1.5 mm x 2.0 mm
TPS2121	VQFN-HR (12)	2.0 mm x 2.5 mm

(1) For all available packages, see the orderable addendum at the end of the data sheet.

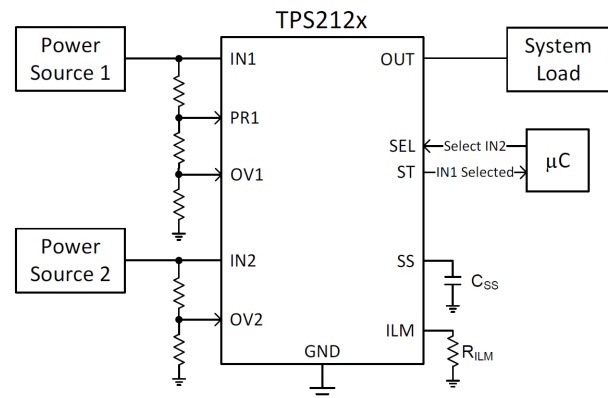

Typical Application



Table of Contents

1 Features	1	10.1 Application Information.....	19
2 Applications	1	10.2 Typical Application.....	19
3 Description	1	10.3 Automatic Switchover with Priority (XCOMP).....	25
4 Revision History	2	10.4 Automatic Seamless Switchover with Priority (XREF).....	27
5 Device Comparison Table	3	10.5 Highest Voltage Operation (VCOMP).....	28
6 Pin Configuration and Functions	4	10.6 Reverse Polarity Protection with TPS212x.....	31
7 Specifications	6	10.7 Hotplugging with TPS212x.....	31
7.1 Absolute Maximum Ratings.....	6	11 Power Supply Recommendations	33
7.2 ESD Ratings.....	6	12 Layout	33
7.3 Recommended Operating Conditions.....	6	12.1 Layout Guidelines.....	33
7.4 Thermal Information.....	6	12.2 Layout Example.....	33
7.5 Electrical Characteristics.....	7	13 Device and Documentation Support	34
7.6 Typical Characteristics.....	9	13.1 Documentation Support.....	34
8 Parameter Measurement Information	10	13.2 Receiving Notification of Documentation Updates.....	34
9 Detailed Description	11	13.3 Support Resources.....	34
9.1 Overview.....	11	13.4 Trademarks.....	34
9.2 Functional Block Diagram.....	11	13.5 Electrostatic Discharge Caution.....	34
9.3 Feature Description.....	12	13.6 Glossary.....	34
9.4 TPS2120 Device Functional Modes.....	18	14 Mechanical, Packaging, and Orderable Information	34
9.5 TPS2121 Device Functional Modes.....	18		
10 Application and Implementation	19		

4 Revision History

NOTE: Page numbers for previous revisions may differ from page numbers in the current version.

Changes from Revision E (February 2020) to Revision F (August 2020)	Page
• Updated the numbering format for tables, figures and cross-references throughout the document	1
Changes from Revision D (September 2019) to Revision E (February 2020)	Page
• Updated the Leakage Current in the <i>Electrical Characteristics</i> table in the <i>Specifications</i> section.....	6
Changes from Revision C (February 2019) to Revision D (September 2019)	Page
• Updated the <i>Reverse Polarity Protection with TPS212x</i> section	31
• Updated the <i>Hotplugging with TPS212x</i> section	31
Changes from Revision B (December 2018) to Revision C (February 2019)	Page
• Changed the Adjustable Overvoltage Supervisor (OVx) Accuracy to $\pm 5\%$ in the <i>Features</i> section.....	1
• Changes made in the <i>Recommended Operating Conditions</i> and <i>Electrical Characteristics</i> table in the <i>Specifications</i> section.....	6
• Changes made in the <i>Active Current Limiting (ILM)</i> section.....	13
• Changed (typical) from 170°C to 160°C in the <i>Thermal Protection (T_{SD})</i> section.....	14
• Changed <i>Equation 8</i> and <i>Equation 9</i>	23
Changes from Revision A (November 2018) to Revision B (December 2018)	Page
• Changed from Advance Information to Production Data.....	1
Changes from Revision * (August 2018) to Revision A (November 2018)	Page
• Changed Wide Operating Range to 2.7 V to 22 V.....	1
• Revised the <i>Application and Implementation</i> section.....	19

5 Device Comparison Table

Part Number	Package	On-Resistance	Maximum Current	Fastest Switchover	Unique Pin
TPS2120	WCSP (20)	62 mΩ	3 A	100 us	SEL
TPS2121	VQFN-HR (12)	56 mΩ	4.5 A	5 us	CP2

6 Pin Configuration and Functions

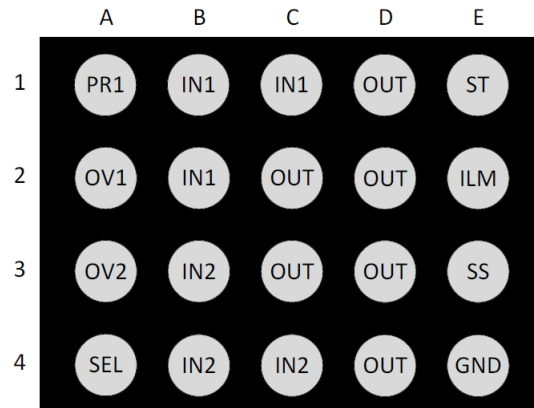

Figure 6-1. TPS2120 (YFP) Package 20-Pin WCSP Bottom View

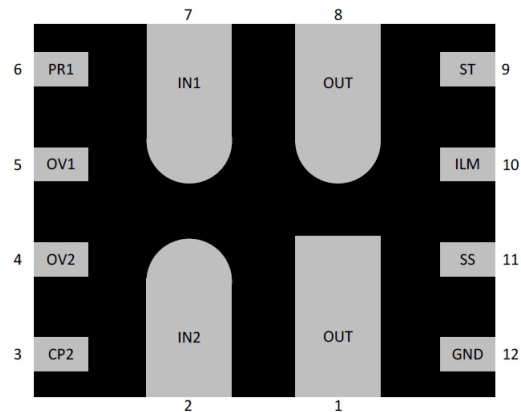

Figure 6-2. TPS2121 (RUX) Package 12-Pin VQFN-HR Bottom View

Pin Functions

NAME	PIN		I/O	DESCRIPTION
	TPS2120 WCSP	TPS2121 VQFN-HR		
IN1	B1, B2, C1	7	I	Power Input for Source 1
IN2	B3, B4, C4	2	I	Power Input for Source 2
OUT	C2, C3, D1, D2, D3, D4	1, 8	I	Power Output
ST	E1	9	O	Status output indicating which channel is selected. Connect to GND if not required.
ILIM	E2	10	O	Output Current Limiting for both channels.
SS	E3	11	O	Adjusts Input Setting Delay Time and Output Soft Start Time
GND	E4	12	—	Device Ground
PR1	A1	6	I	Enables Priority Operation. Connect to IN1 to set switchover voltage. Connect to GND if not required.
OV1	A2	5	I	Active Low Enable Supervisor for IN1 Overvoltage Protection. Connect to GND if not required.
OV2	A3	4	I	Active Low Enable Supervisor for IN2 Overvoltage Protection. Connect to GND if not required.
SEL	A4	—	I	Active low Enable for IN1. Allows GPIO to override priority operation and manually select IN2. TPS2120 only.

Pin Functions (continued)

PIN			I/O	DESCRIPTION
NAME	TPS2120	TPS2121		
	WCSP	VQFN-HR		
CP2	—	3	I	Enables Comparator Operation and is compared to PR1 to set switchover voltage. Connect to GND if not required. TPS2121 only.

7 Specifications

7.1 Absolute Maximum Ratings

over operating free-air temperature range (unless otherwise noted)⁽¹⁾

		Pins	MIN	MAX	UNIT
$V_{IN1}, V_{IN2}, V_{OUT}$	Maximum Power Pin Voltage	IN1, IN2, OUT	-0.3	24	V
V_{OV1}, V_{OV2}	Maximum Overvoltage Pin Voltage	OV1, OV2	-0.3	6	V
V_{PRI}, V_{SEL}	Maximum Control Pin Voltage	PRI, SEL	-0.3	6	V
V_{ST}	Maximum Control Pin Voltage	ST	-0.3	6	V
I_{OUT}	Maximum Output Current	OUT	Internally Limited		
$T_{J, MAX}$	Maximum Junction Temperature		Internally Limited		
T_{STG}	Storage temperature		-65	150	°C

- (1) Stresses beyond those listed under *Absolute Maximum Rating* may cause permanent damage to the device. These are stress ratings only, which do not imply functional operation of the device at these or any other conditions beyond those indicated under *Recommended Operating Condition*. Exposure to absolute-maximum-rated conditions for extended periods may affect device reliability.

7.2 ESD Ratings

			Pins	VALUE	UNIT
V_{ESD}	Electrostatic discharge	Human body model (HBM), per ANSI/ESDA/ JEDEC JS-001, ⁽¹⁾	All	±2000	V
		Charged device model (CDM), per JEDEC specification JESD22-C101, ⁽²⁾	All	±500	

- (1) JEDEC document JEP155 states that 500-V HBM allows safe manufacturing with a standard ESD control process.
(2) JEDEC document JEP157 states that 250-V CDM allows safe manufacturing with a standard ESD control process.

7.3 Recommended Operating Conditions

over operating free-air temperature range (unless otherwise noted)

		Pins	MIN	MAX	UNIT
V_{IN1}, V_{IN2}	Input Voltage Range ⁽¹⁾	IN1, IN2	2.8	22	V
V_{OUT}	Output Voltage Range	OUT	0	22	V
V_{OV1}, V_{OV2}	Overvoltage Pin Voltage	OV1, OV2	0	5.5	V
V_{PRI}, V_{SEL}	Control Pin Voltage	PRI, SEL	0	5.5	V
V_{ST}	Control Pin Voltage	ST	0	5.5	V
R_{ST}	Status Pin Pull Up Resistance	ST	6	20	kΩ
R_{ILM}	Current Limit Resistance	ILM	18	100	kΩ
V_{SS}	SS Pin Output Voltage	SS		4	V
I_{IN1}, I_{IN2}	TPS2120 Continuous Input Current	IN1, IN2		3	A
I_{IN1}, I_{IN2}	TPS2121 Continuous Input Current	IN1, IN2		4.5	A
T_J	Junction temperature	-	-40	125	°C

- (1) See Power Supply Recommendations Section for more Details

7.4 Thermal Information

THERMAL METRIC ⁽¹⁾		TPS2120	TPS2121	UNIT
		YFP (WCSP)	RNW (PKG FAM)	
		20 PINS	11 PINS	
$R_{\theta JA}$	Junction-to-ambient thermal resistance	72.5	72.2	°C/W

7.4 Thermal Information (continued)

THERMAL METRIC ⁽¹⁾		TPS2120	TPS2121	UNIT
		YFP (WCSP)	RNW (PKG FAM)	
		20 PINS	11 PINS	
R _{θJC(top)}	Junction-to-case (top) thermal resistance	0.5	38.5	°C/W
R _{θJB}	Junction-to-board thermal resistance	16.4	15.4	°C/W
Ψ _{JT}	Junction-to-top characterization parameter	0.3	0.9	°C/W
Ψ _{JB}	Junction-to-board characterization parameter	16.6	15.5	°C/W
R _{θJC(bot)}	Junction-to-case (bottom) thermal resistance	N/A	N/A	°C/W

(1) For more information about traditional and new thermal metrics, see the [Semiconductor and IC Package Thermal Metrics](#) application report.

7.5 Electrical Characteristics

over operating free-air temperature range (unless otherwise noted)

PARAMETER		TEST CONDITIONS	T _J	MIN	TYP	MAX	UNIT
INPUT SOURCE (IN1, IN2)							
I _{Q, INx}	Quiescent Current (INx Powering OUT) ⁽¹⁾	OUT = Open	-40°C to 125°C		300	400	μA
I _{SBY, INx}	Standby Current (INx not powering OUT) ⁽¹⁾	V _{OUT} = V _{INx}	25°C	0	15	25	μA
I _{LK, INx}	Leakage Current (INx to OUT)	V _{INx} - V _{OUT} ≤ 5V	25°C	-1		1	μA
			-40°C to 85°C	-5		5	μA
			-40°C to 125°C	-80		80	μA
		V _{INx} - V _{OUT} ≤ 22V	25°C	-1		1	μA
			-40°C to 85°C	-35		35	μA
			-40°C to 125°C	-500		500	μA
V _{UV, INx}	Undervoltage Lockout	V _{INx} Rising	-40°C to 125°C	2.5	2.65	2.8	V
		V _{INx} Falling	-40°C to 125°C	2.4	2.55	2.7	V
OUTPUT SWITCHOVER (OUT)							
t _{SW}	Switchover Time	V _{OUT} < V _{INx} CP2 or SEL < V _{REF}	-40°C to 125°C		100		μs
t _{FSW}	Fast Switchover Time (TPS2121 only)	V _{OUT} < V _{INx} CP2 ≥ V _{REF}	-40°C to 125°C		5		μs
V _{COMP}	Input Voltage Comparator (V _{IN2} referenced to V _{IN1})	V _{IN1} ≥ V _{IN2}	-40°C to 125°C	0	280	600	mV
		V _{IN1} > V _{IN2} , Falling Hysteresis	-40°C to 125°C	2.5	3.5	4.5	%
ON-RESISTANCE (INx to OUT)							
R _{ON}	ON-State Resistance (TPS2120)	I _{OUT} = -200 mA V _{PRI} > V _{REF} V _{INx} ≥ 5.0 V	25°C		62	75	mΩ
			-40°C to 85°C			90	mΩ
			-40°C to 105°C			100	mΩ
			-40°C to 125°C			120	mΩ
	ON-State Resistance (TPS2121)	I _{OUT} = -200 mA V _{PRI} > V _{REF} V _{INx} ≥ 5.0 V	25°C		56	70	mΩ
			-40°C to 85°C			85	mΩ
			-40°C to 105°C			90	mΩ
			-40°C to 125°C			100	mΩ
CURRENT LIMIT (ILM)							

7.5 Electrical Characteristics (continued)

over operating free-air temperature range (unless otherwise noted)

PARAMETER		TEST CONDITIONS	T _J	MIN	TYP	MAX	UNIT
I _{LM} ⁽²⁾	Output Current Limit (TPS2120)	R _{ILM} = 31.6kΩ	-40°C to 125°C	3	3.5	4	A
		R _{ILM} = 46.4kΩ	-40°C to 125°C	2	2.5	3	A
		R _{ILM} = 85kΩ	-40°C to 125°C	1	1.5	2	A
		R _{ILM} < 1kΩ	-40°C to 125°C	1.5	2.5	3.5	A
	Output Current Limit (TPS2121)	R _{ILM} = 18.7kΩ	-40°C to 125°C	4.6	5.2	5.8	A
		R _{ILM} = 22.1kΩ	-40°C to 125°C	4	4.5	5	A
		R _{ILM} = 29.8kΩ	-40°C to 125°C	3	3.5	4	A
		R _{ILM} = 44.2kΩ	-40°C to 125°C	2	2.5	3	A
		R _{ILM} = 80kΩ	-40°C to 125°C	1	1.5	2	A
		R _{ILM} < 1kΩ	-40°C to 125°C	1.5	2.5	3.5	A
t _{LM} ⁽³⁾	Current Limit Response Time	Output Steady State	-40°C to 125°C		250		μs
CONTROL PINS (PRI, SEL, OV1, OV2)							
V _{REF, x}	Internal Voltage Reference	V _{PR1} , V _{CP2} , V _{OV1} , V _{OV2} Rising	-40°C to 125°C	1.01	1.06	1.1	V
		V _{PR1} , V _{CP2} , V _{OV1} , V _{OV2} Falling	-40°C to 125°C	0.99	1.04	1.09	V
V _{OFST}	Comparator Offset Voltage (TPS2121 only)	V _{PR1} > V _{REF} V _{CP2} > V _{REF}	-40°C to 125°C	5	20	40	mV
I _{LK, x}	Pin Leakage Current	V _{PR1} , V _{CP2} , V _{OV1} , V _{OV2} = 0 V to 5.5 V	-40°C to 125°C	-0.1		0.1	μA
STATUS INDICATION PIN (ST)							
I _{LK, ST}	Pin Leakage	V _{ST} = 0 V to 5.5 V	-40°C to 125°C	-0.1		0.1	μA
t _{ST}	Status Delay	L to H	-40°C to 125°C		1		μs
FAST REVERSE CURRENT BLOCKING (RCB)							
I _{RCB}	Fast Reverse Current Detection Threshold	V _{OUT} > V _{INx}	-40°C to 125°C	0.2	1	2	A
V _{RCB}	RCB Release Voltage	V _{OUT} > V _{INx}	-40°C to 125°C	0	25	50	mV
t _{RCB}	Fast Reverse Current Blocking Response Time		-40°C to 125°C		10		μs
THERMAL SHUTDOWN (TSD)							
T _{SD}	Thermal Shutdown	Shutdown	Rising		160		°C
		Recovery	Falling		150		°C

- (1) When PR1 < V_{REF}, CP2 < V_{REF}, and |V_{IN1}-V_{IN2}| < 1V, Quiescent current can be drawn from both IN1 and IN2 with combined current not to exceed I_{Q,INx}.
- (2) The current limit can be measured by forcing a voltage differential from VIN to VOUT. This value must be at least 200mV greater than the voltage drop across the device at the current limit threshold (I_{LM} x R_{ON(MAX)}). For example, the TPS2121 would need a minimum voltage drop of (1.5A x 100mΩ + 200mV) = 350mV from VIN to VOUT for a current limit setting of 1.5A (typical).
- (3) For more information on device behavior during short circuit conditions, see Section 9.3.3.

7.6 Typical Characteristics

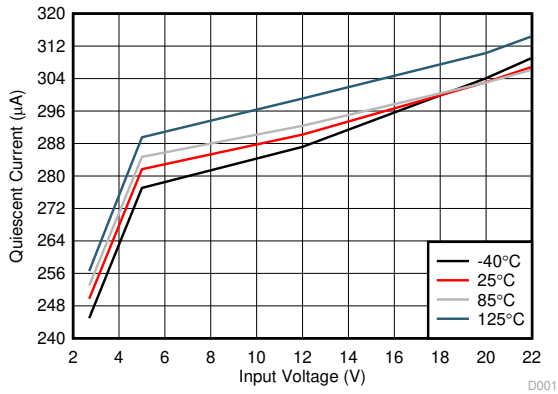

ILM = 5.2A

Figure 7-1. Quiescent Current vs Input Voltage

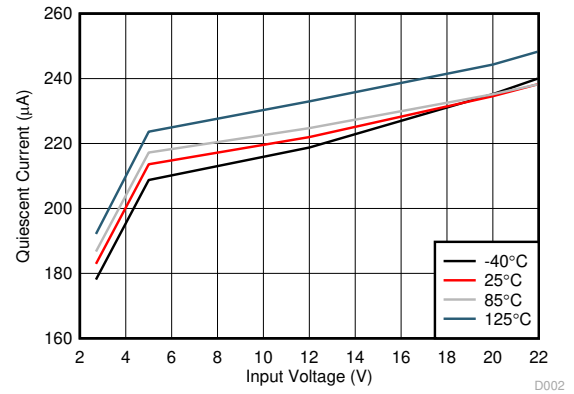

ILM = 1.5A

Figure 7-2. Quiescent Current vs Input Voltage

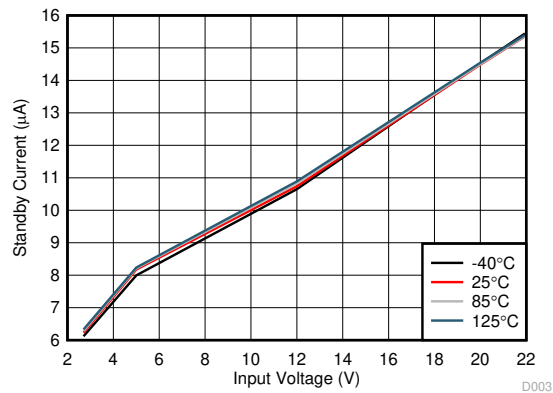

ILM = 5.2A

Figure 7-3. Standby Current vs Input Voltage

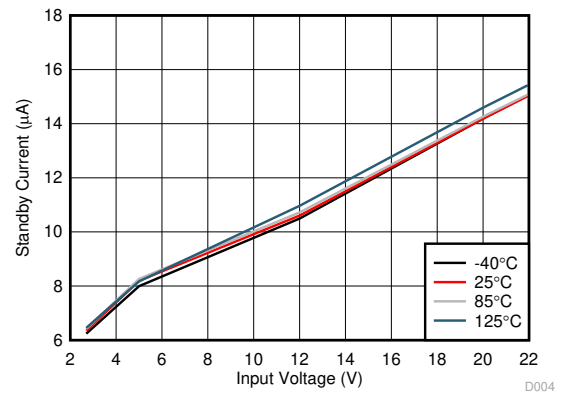

ILM = 1.5A

Figure 7-4. Standby Current vs Input Voltage

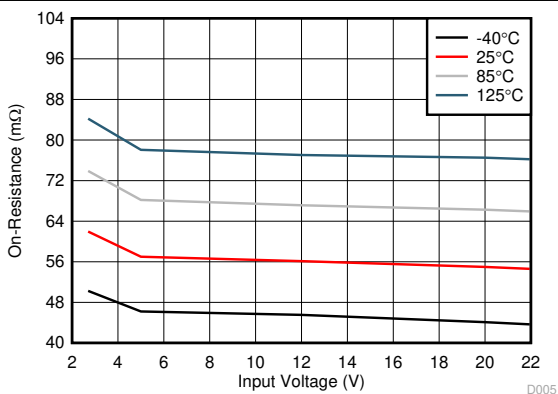

$I_{OUT} = -200 \text{ mA}$

Figure 7-5. TPS2121 On-Resistance vs Input Voltage

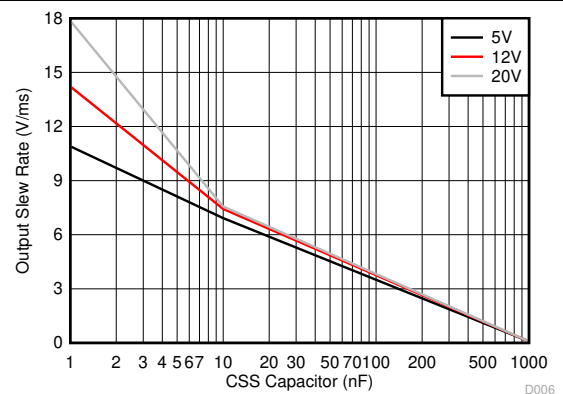

$V_{IN1} > UVLO$

$V_{IN2} = 0V$

Figure 7-6. Output Slew Rate vs CSS Capacitor

TPS2120, TPS2121

SLVSEA3F – AUGUST 2018 – REVISED AUGUST 2020

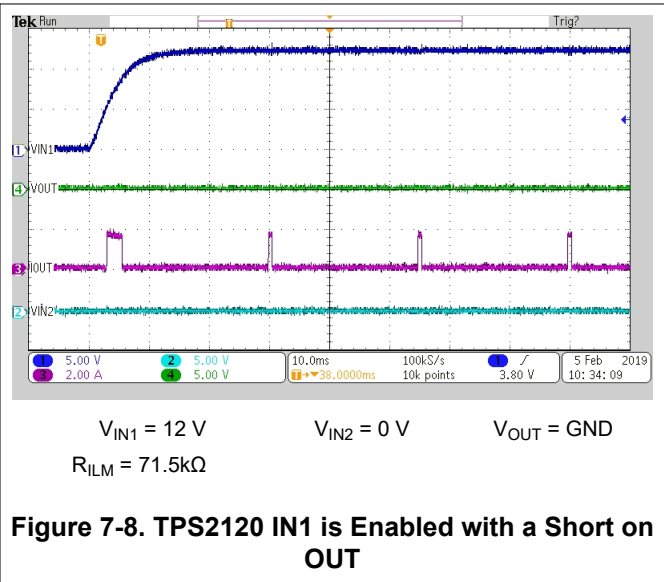
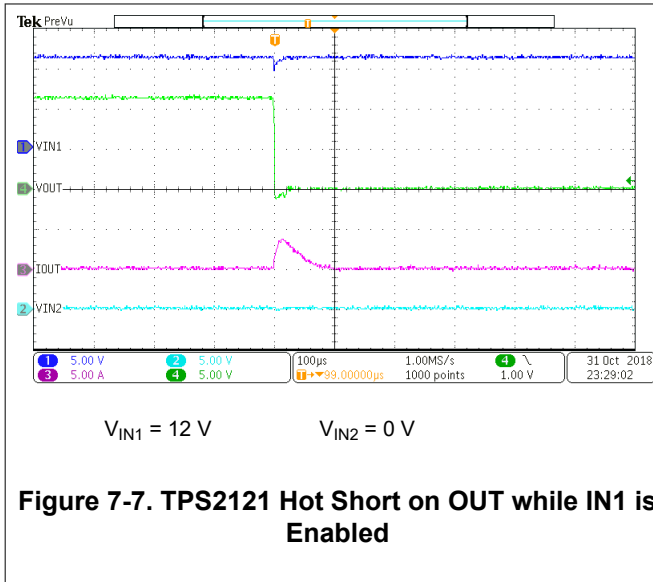

8 Parameter Measurement Information

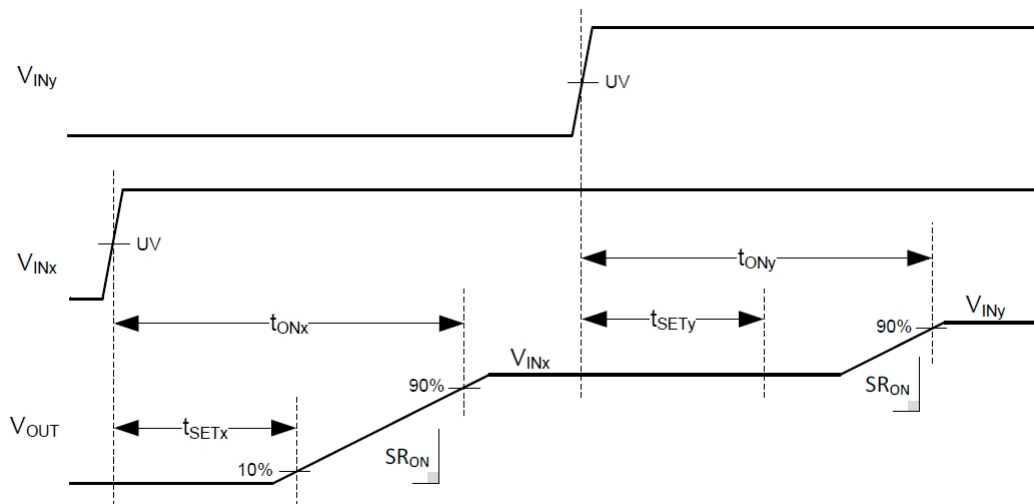

Figure 8-1. Timing Parameter Diagram

9 Detailed Description

9.1 Overview

The TPS212x devices are Dual-Input, Single-Output (DISO) Power Multiplexer (MUX) that are well suited for a variety of systems having multiple power sources. The devices will automatically detect, select, and seamlessly transition between available inputs. Priority can be automatically given to the highest input voltage or manually assigned to a lower voltage input to support both ORing and Source Selection operations. A priority voltage supervisor is used to select an input source.

An Ideal Diode operation is used to seamlessly transition between input sources. During switchover, the voltage drop is controlled to block reverse current before it happens and provide uninterrupted power to the load with minimal hold-up capacitance. Active current limiting is used during startup and switchover to protect against overcurrent, and also protects the device during normal operation. The output current limit can be adjusted with a single external resistor.

9.2 Functional Block Diagram

The below figures show the block diagrams for the TPS2120 and TPS2121. The TPS2120 has the SEL pin, while the TPS2121 has the CP2 pin and supports fast switchover.

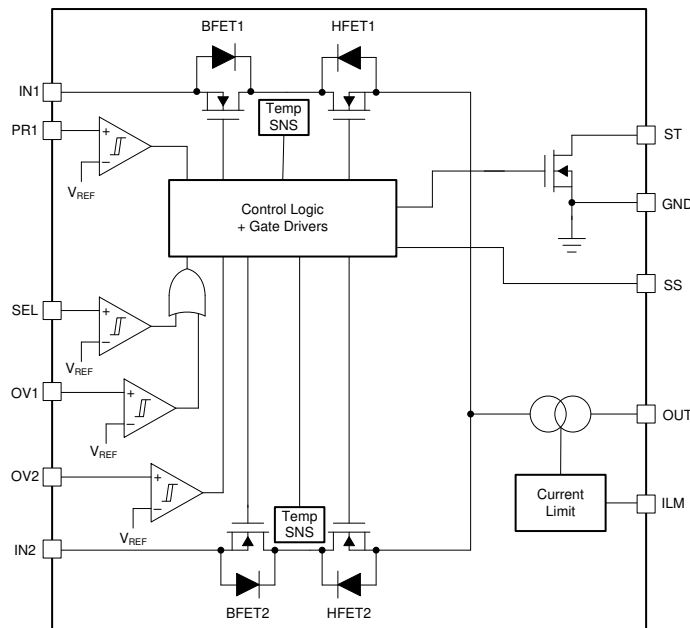

Figure 9-1. TPS2120 Functional Block Diagram

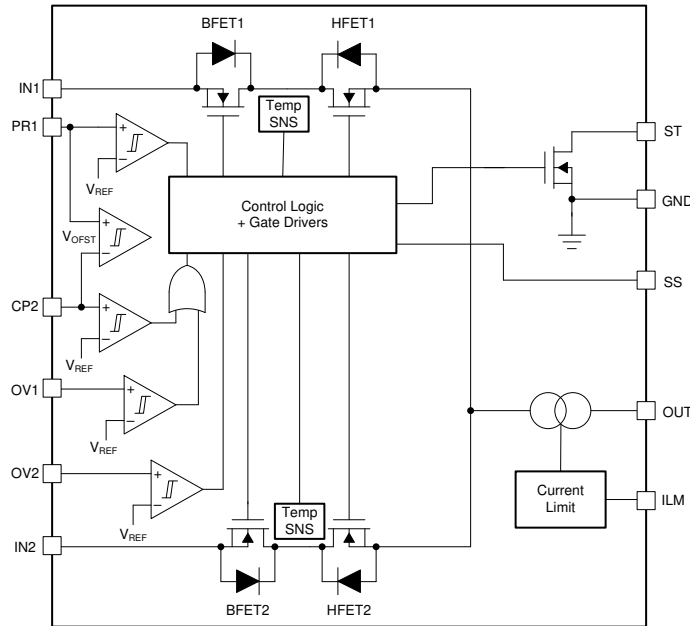

Figure 9-2. TPS2121 Functional Block Diagram

9.3 Feature Description

This section describes the different features of the TPS212x power mux device.

9.3.1 Input Settling Time and Output Soft Start Control (SS)

The TPS212x will automatically select the first source to become valid ($IN_x > UV$ and $IN_x < OV$). The external capacitor (CSS) will then be used as a timer to wait for the input to finish settling (t_{SETx}). When the settling timer has expired, CSS will continue to charge and set the output slew rate (SRON) for a soft start. After the total turn on time (t_{ONx}), soft start will not be used again for IN_x until it ceases to be valid ($IN_x < UV$ or $IN_x > OV$).

When the second source becomes valid ($IN_y > UV$ and $IN_y < OV$), the external capacitor (CSS) will be used again for a second settling time (t_{SETy}). After t_{SETy} , the TPS212x will decide whether to continue sourcing the first source, or switchover to the second source. If the second source is selected at the end of t_{SETy} , then CSS will be reused to set the output slew rate (SRON) for a second soft start. After the total turn on time (t_{ONy}), soft start will not be used again for IN_y until it ceases to be valid ($IN_y < UV$ or $IN_y > OV$).

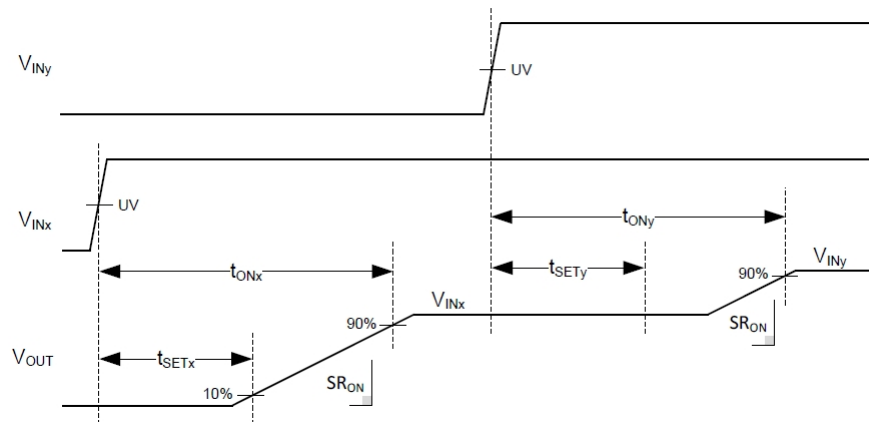

Figure 9-3. Settling and Soft Start Timing

If IN_y becomes valid before the end of t_{ONx} , t_{SETy} will be delayed and start after t_{ONx} has ended.

If INy is not selected during tSETy, a second soft start will not take place, skipping tONy, and CSS will be retired until one of the inputs ceases to be valid.

9.3.1.1 Slew Rate vs. CSS Capacitor

Table 9-1 shows the estimated slew rate across CSS capacitance and VIN.

Table 9-1. Slew Rate vs. CSS Capacitor

CSS CAPACITOR	VIN = 5 V	VIN = 12 V	VIN = 20 V	UNITS
100 nF	780	800	880	V/s
1 uF	88	92	92	V/s
10 uF	8.8	9.6	10.4	V/s

9.3.2 Active Current Limiting (ILM)

The load current is monitored at all times. When the load current exceed the current limit trip point ILM programmed by RILM resistor, the device regulates the current within t_{ILM}. The following equations can be used to find the RILM value for a desired current limit, where RILM is in kΩ and between 18 kΩ to 100 kΩ.

$$\text{TPS2120: } I_{LM} = \frac{69.1}{R_{ILM}^{0.861}} \quad (1)$$

$$\text{TPS2121: } I_{LM} = \frac{65.2}{R_{ILM}^{0.861}} \quad (2)$$

During current regulation, the output voltage will drop resulting in increased device power dissipation. If the device junction temperature (T_j) reaches the thermal shutdown threshold (TSD) the internal FETs are turned off. After cooling down, the device will automatically restart.

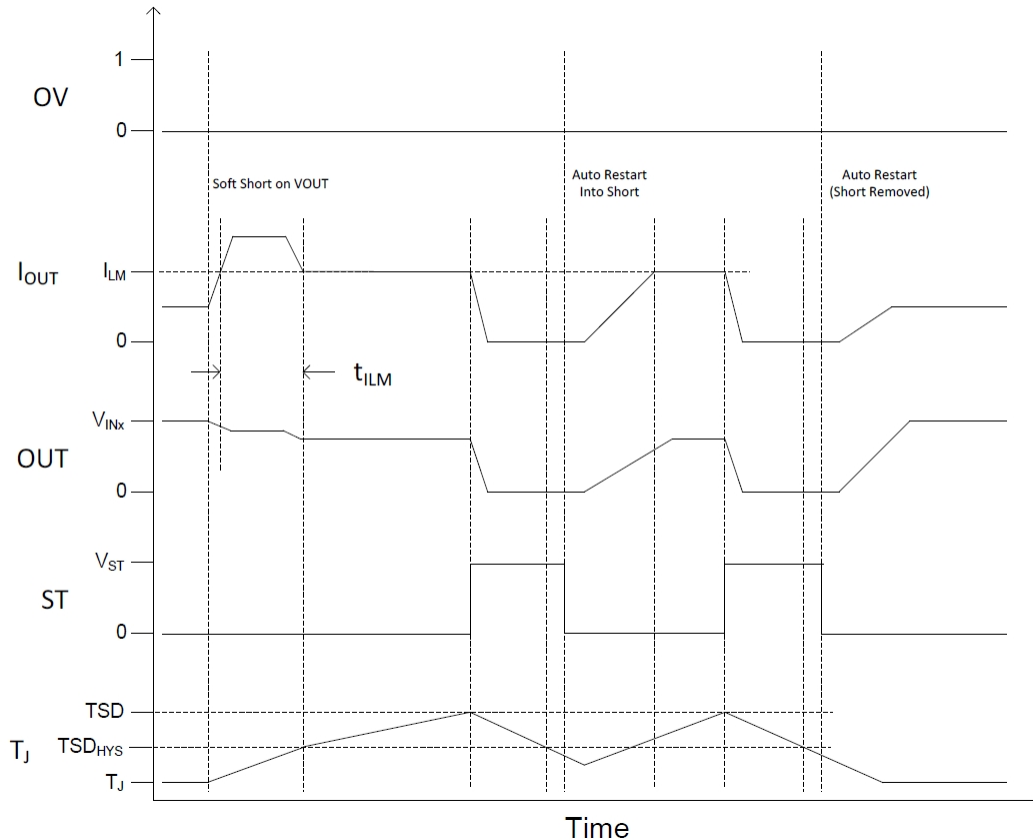

Figure 9-4. Current Limiting Behavior

9.3.3 Short-Circuit Protection

During a transient short circuit event, the current through the device increases very rapidly. As the current-limit amplifier cannot respond quickly to this event due to its limited bandwidth, the device incorporates a fast-trip overcurrent protection (OCP) comparator, with a threshold I_{OCP} . This comparator shuts down the pass device within $1\ \mu\text{s}$, when the current through internal FET I_{OUT} exceeds I_{OCP} ($I_{OUT} > I_{OCP}$). The trip threshold is set to about 2.4x of the programmed current limit $I_{OCP} = 2.4 \times I_{LM}$. The OCP circuit holds the internal FET off for about 25 ms, after which the device turns back on. If the short is still present then the current-limit loop will regulate the output current to I_{LM} and behave in a manner similar to a power up into a short.

9.3.4 Thermal Protection (T_{SD})

The TPS212x devices have built-in absolute thermal shutdown and relative thermal shutdown to ensure maximum reliability of the power mux. The absolute thermal shutdown is designed to disable the power FETs, if the junction temperature exceeds 160°C (typical). The device auto recovers about 25 ms after $T_J < [T(TSD) - 10^\circ\text{C}]$. The relative thermal shutdown protects the device by turning off when the temperature of the power FETs increases sharply such that the FET temperature rises about 60°C above the rest of the die. The device auto recovers about 25 ms after the FETs cool down by 20°C . The relative thermal shutdown is critical for protecting the device against faults such as a power up into a short which causes the FET temperature to increase sharply.

9.3.5 Overvoltage Protection (OVx)

Output Overvoltage Protection is available for both IN1 and IN2 in case either applied voltage is greater than the maximum supported load voltage. The VREF comparator on the OVx pins allow for the Overvoltage Protection threshold to be adjusted independently for each input. When overvoltage is engaged, the corresponding channel will turn off immediately. Fast switchover to the other input is supported if it is a valid voltage.

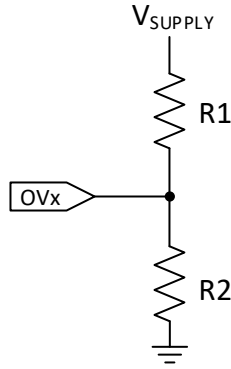

Figure 9-5. OVP Resistor Configuration

9.3.6 Fast Reverse Current Blocking (RCB)

Each channel has the always on reverse current blocking. If the output is forced above the selected input by V_{IRCB} , the channel will switch off to stop the reverse current I_{RCB} within t_{RCB} . As the output falls to within V_{RCB} of V_{IN} , the selected channel will quickly turn back on to avoid unnecessary voltage drops during fast switchover (t_{SW}).

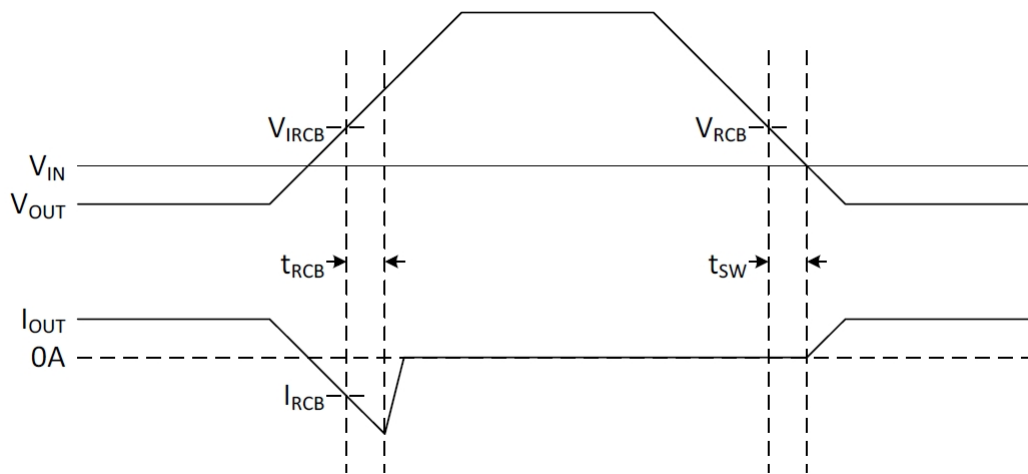

Figure 9-6. Reverse Current Blocking Behavior

9.3.7 Output Voltage Dip and Fast Switchover Control (TPS2121 only)

After input settling and soft start time, the TPS2121 utilizes a fast switchover to minimize output voltage drop. Where V_{SW} is the output voltage when the switchover is triggered and t_{SW} is the time until the output voltage stops dipping. The amount of voltage dip during the switchover time is a function of output load current (I_{OUT}) and load capacitance (C_{OUT}). The minimum output voltage during switchover can be found using the following equations:

$$V_{OUT,MIN} = V_{SW} - V_{DIP} \quad (3)$$

Where:

$$V_{DIP} = t_{SW} \times \left(\frac{I_{OUT}}{C_{OUT}} \right) \quad (4)$$

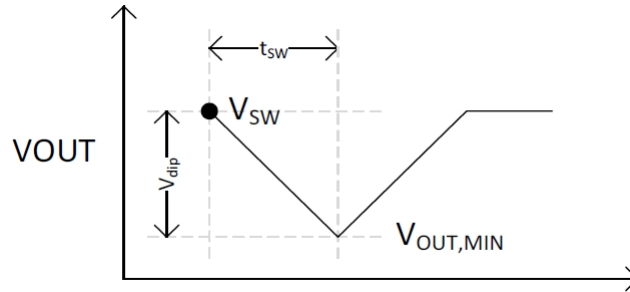
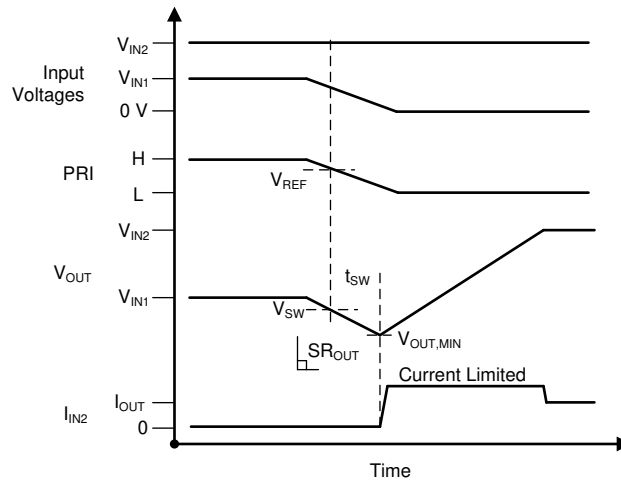

Figure 9-7. Minimum Output Voltage During Fast Switchover

If switching from a lower to a higher voltage, the selected channel will not detect reverse voltage and shall turn on immediately using the current monitor to limit the output current to a safe level. If the output current reaches the current limit during fast switchover, this will increase the total time until the output reaches steady state.



$$V_{OUT,MIN} = V_{SW} - (t_{sw} \times SR_{OUT}) \text{ where } SR_{OUT} = I_{OUT}/C_{OUT}$$

$$V_{OUT,MIN} = 3.5 \text{ V} - (5\mu\text{s} \times 30\text{mV}/\mu\text{s}) = 3.35 \text{ V}$$

$$V_{OUT,MIN} = 3.5 \text{ V} - (5\mu\text{s} \times 1\text{A}/10\mu\text{F}) = 3 \text{ V}$$

$$V_{OUT,MIN} = 3.5 \text{ V} - (5\mu\text{s} \times 1\text{A}/100\mu\text{F}) = 3.45 \text{ V}$$

Figure 9-8. Fast Switchover from Lower to Higher Voltage

If an input is selected while the output voltage is still a higher voltage, that channel will continue to block reverse current by waiting to fast turn on until the output drops below the V_{RCB} threshold.

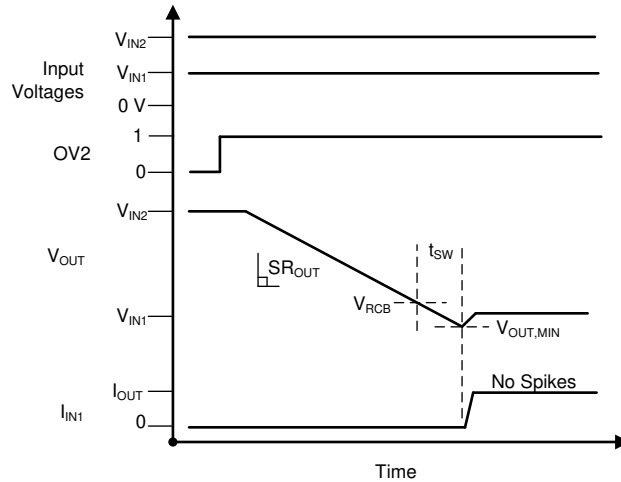

$$V_{OUT,MIN} = V_{IN1} + V_{RCB} - (t_{SW} \times SR_{OUT}) \text{ where } SR_{OUT} = I_{OUT}/C_{OUT}$$

$$V_{OUT,MIN} = 4.25 \text{ V} + 50 \text{ mV} - (5\mu\text{s} \times 30\text{mV}/\mu\text{s}) = 4.15 \text{ V}$$

$$V_{OUT,MIN} = 4.25 \text{ V} + 50 \text{ mV} - (5\mu\text{s} \times 1\text{A}/10\mu\text{F}) = 3.8 \text{ V}$$

$$V_{OUT,MIN} = 4.25 \text{ V} + 50 \text{ mV} - (5\mu\text{s} \times 1\text{A}/100\mu\text{F}) = 4.25 \text{ V}$$

Figure 9-9. Fast Switchover from Higher to Lower Voltage

9.3.8 Input Voltage Comparator (VCOMP)

If both PR1 and CP2 are < VREF, the device will use an internal comparator between the two inputs to determine the priority source. VCOMP is configured to ensure IN2 will take priority if the input voltages are equal. If IN2 falls below the VCOMP Hysteresis, then IN1 will have priority.

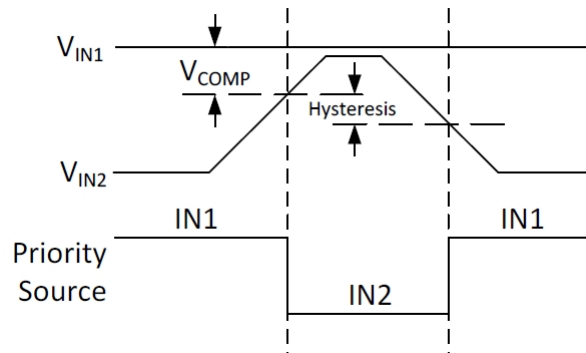

Figure 9-10. VCOMP Priority Source Selection

9.4 TPS2120 Device Functional Modes

Table 9-2 shows the TPS2120 functional behavior.

Table 9-2. TPS2120 Output Source Selection Table

DEVICE INPUTS				DEVICE OUTPUTS		MODE OF OPERATION
IN1 ≤ UV OR OV1 ≥ VREF OR SEL ≥ VREF	IN2 ≤ UV OR OV2 ≥ VREF	PR1 ≥ VREF	VCOMP	OUT	ST	MODE
0	0	0	IN2 < IN1	IN1	H	VCOMP
0	0	0	IN2 ≥ IN1	IN2	L	VCOMP
0	0	1	X	IN1	H	VREF
0	1	X	X	IN1	H	Invalid Input
1	0	X	X	IN2	L	SEL / Invalid Input
1	1	X	X	Hi-Z	H	Invalid Inputs

A summary of the operation of the TPS2120 device can be found below:

- If only one input voltage is valid (above UV and below OV) then that input will power the output.
- If both inputs are not valid, then the output is Hi-Z.
- ST is pulled high when the output is Hi-Z or IN1. It is pulled low when IN2 is powering the output.
- If both inputs are valid and PR1 is pulled high (higher than VREF, 1.06-V typical), then IN1 is used.
- If both inputs are valid and PR1 is pulled low, then the highest voltage input is used.

9.5 TPS2121 Device Functional Modes

Table 9-3 shows the TPS2121 functional behavior.

Table 9-3. TPS2121 Output Source Selection Table

DEVICE INPUTS						DEVICE OUTPUTS		MODE OF OPERATION
IN1 ≤ UV OR OV1 ≥ VREF	IN2 ≤ UV OR OV2 ≥ VREF	CP2 ≥ VREF	PR1 ≥ VREF	VCOMP	XCOMP	OUT	ST	MODE
0	X	0	0	IN2 < IN1	X	IN1	H	VCOMP
X	0	0	0	IN2 ≥ IN1	X	IN2	L	VCOMP
0	X	0	1	X	X	IN1	H	VREF
X	0	1	0	X	X	IN2	L	VREF
0	X	1	1	X	PR1 > CP2	IN1	H	XCOMP / XREF
X	0	1	1	X	PR1 ≤ CP2	IN2	L	XCOMP / XREF
0	1	X	X	X	X	IN1	H	Invalid Input
1	0	X	X	X	X	IN2	L	Invalid Input
1	1	X	X	X	X	Hi-Z	H	Invalid Inputs

A summary of the operation of the TPS2121 device can be found below:

- If only one input voltage is valid (above UV and below OV) then that input will power the output.
- If both inputs are not valid, then the output is Hi-Z.
- ST is pulled high when the output is Hi-Z or IN1. It is pulled low when IN2 is powering the output.
- If CP2 is pulled low, then the TPS2121 ignores this pin.
- When CP2 is pulled high, this enables fast switchover and is compared to PR1. If PR1 > CP2 then IN1 is used, and if PR1 < CP2 then IN2 is used.
- If both inputs are valid, CP2 is low, and PR1 is pulled high, (higher than VREF, 1.06-V typical), then IN1 is used.
- If both inputs are valid, CP2 is low, and PR1 is pulled low, then the highest voltage input is used.

10 Application and Implementation

Note

Information in the following applications sections is not part of the TI component specification, and TI does not warrant its accuracy or completeness. TI's customers are responsible for determining suitability of components for their purposes. Customers should validate and test their design implementation to confirm system functionality.

10.1 Application Information

The TPS212x device is a highly configurable power mux that can be designed to meet various application requirements. When designing the TPS212x for a power mux configuration, 3 key factors should be considered:

- VOUT voltage dip
- Manual and Automatic Switchover
- Switchover Time

The TPS212x device can be configured in various modes to meet these considerations and provides a general table that describes each mode of operation. This application section will highlight 3 common modes of operation that address these factors.

10.2 Typical Application

[Table 10-1](#) summarizes the applications highlighted in the following sections.

Table 10-1. TPS212x Application Summary Table

MODE	DEVICE(S)	DESCRIPTION	SECTION
Manual Switchover	TPS2120 / TPS2121	An external controller (such as an MCU) can be used to manually select between the two input sources.	11.2.1
Automatic Switchover with Priority (XCOMP)	TPS2121	Prioritizes Supply 1 when present, and quickly switches to Supply 2 when Supply 1 drops.	11.3
Automatic Switchover with Priority (XREF)	TPS2121	Prioritizes Supply 1 when present, and quickly switches to Supply 2 when Supply 1 drops. An external supply is used to increase the accuracy of the comparator for switchover.	11.4
Highest Voltage Operation (VCOMP)	TPS2120 / TPS2121	The device automatically selects the highest voltage supply to power the output.	11.5

10.2.1 Manual Switchover Schematic

Figure 10-1 and Figure 10-2 show the application schematic for manual switchover on the TPS2120 and TPS2121.

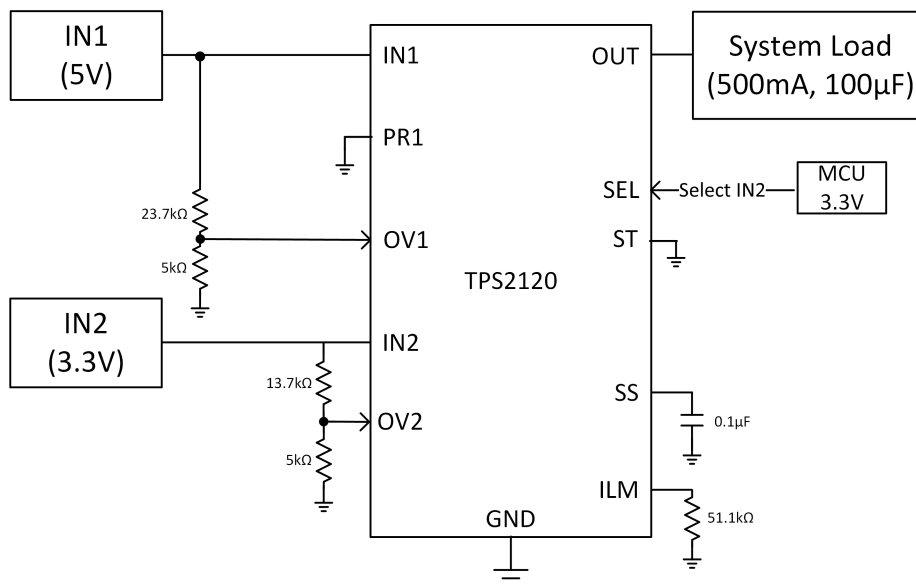

Figure 10-1. TPS2120 Manual Switchover

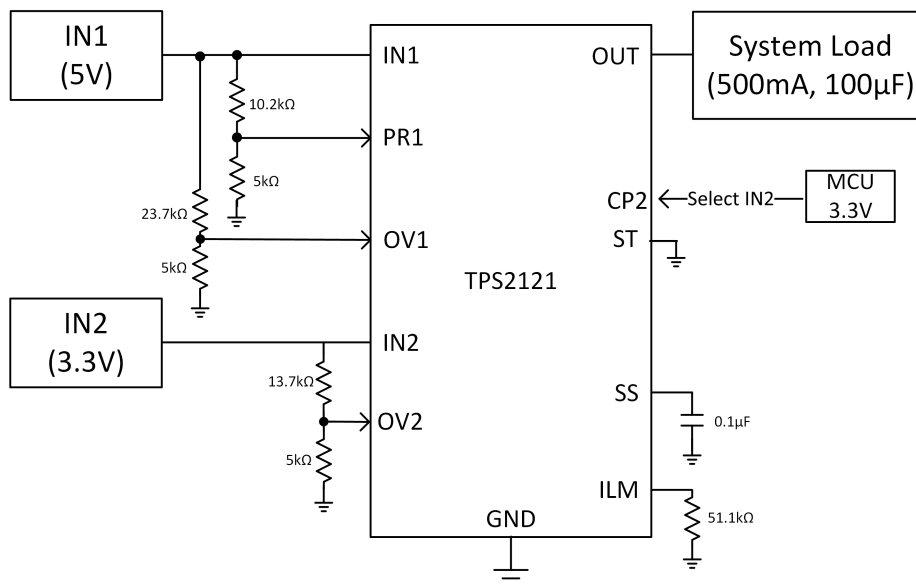

Figure 10-2. TPS2121 Manual Switchover

10.2.2 Design Requirements

In certain power architectures, an external MCU or controller monitors the downstream load. If the controller needs to select between multiple supplies, the controller can manually switch between inputs through a single GPIO. In this configuration, an external signal will switch between two input supplies, a 5-V supply (IN1) and a 3.3-V supply (IN2). Table 10-2 summarizes the design parameters for this example.

Table 10-2. Manual Switchover Design Requirements

DESIGN PARAMETER	SPECIFICATION	DETAILS
IN1 Voltage	V_{IN1}	5 V
IN2 Voltage	V_{IN1}	3.3 V
Load Current	I_{OUT}	500 mA
Load Capacitance	C_L	100 μ F
Maximum Inrush Current	I_{INRUSH}	100 mA
Current Limit		2 A
Switchover Time	t_{SW}	TPS2121: 5 μ s TPS2120: 100 μ s
Mode of Operation	Manual Switchover	TPS2120: VREF TPS2121: XREF
External MCU Signal	V_{MCU}	3.3 V
Overvoltage Protection	V_{OV1} V_{OV2}	OV1 : 6.1 V OV2: 4 V

10.2.3 Detailed Design Description

The TPS212x devices can be configured to manually switch between IN1 and IN2 through an external GPIO. In this example, an external MCU signal is selecting between main power and auxiliary power to power a downstream load. By manually toggling the TPS212x, the device will switch between both sources, even if one supply is higher than the other supply. Ultimately, the main factor that will determine the switchover time between IN1 (5 V) and IN2 (3.3 V) is the output load.

Manual switchover can be enabled by configuring the TPS212x for internal voltage reference control scheme (VREF). In the VREF scheme, if the voltage on PR1 is higher than the internal VREF voltage, 1.06 V (typical), the device will select IN1 as the output. If the voltage on PR1 drops below VREF, then the device will switch to IN2, as long as IN2 is presenting a valid input voltage. IN1 is commonly connected to PR1 with an external resistor divider. OV1 and OV2 can be configured to provide overvoltage protection. The ST pin can be pulled high with a resistor to provide feedback on the status of the system. If the status pin is high, IN1 is the output. If the pin is low, IN2 is the output. If this feature is not required, the ST pin can be connected to GND.

On the TPS2120, by connecting an external signal to the select pin (SEL), the device can override the PR1/VREF comparison. If the voltage on SEL is higher than VREF at approximately (1.06 V), then the device will select IN2, as shown on [Table 9-2](#). If the voltage on SEL drops below VREF, then the device will switch to IN1 as long as PR1 \geq VREF. Otherwise, the highest voltage input will be chosen between IN1 and IN2. In this example, since the IN1 is higher than IN2, at 5 V, it will be selected.

Figure 10-3 shows the application schematic for this design example on the TPS2120.

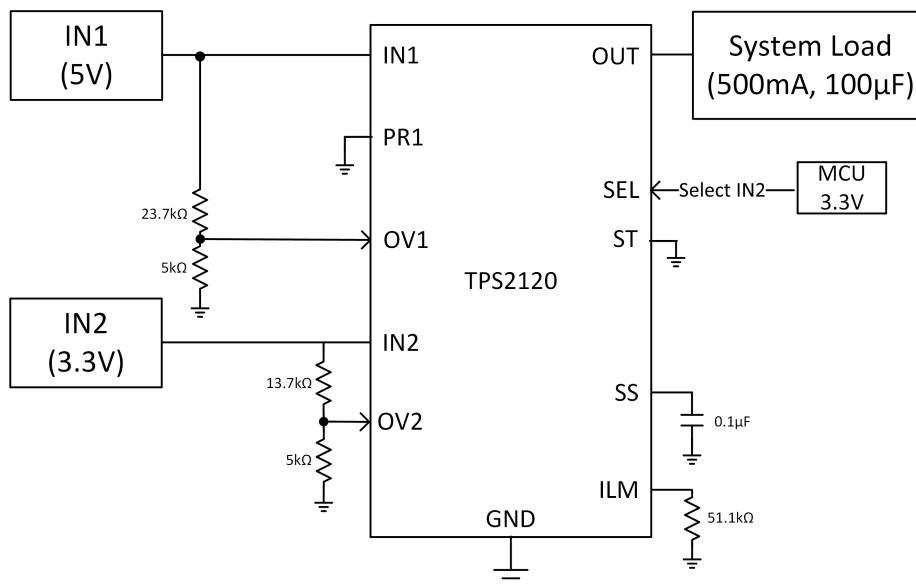

Figure 10-3. TPS2120 Manual Switchover

On the TPS2121, fast switchover can be enabled to minimize the voltage drop on VOUT. The internal comparator will detect and seamlessly switch between IN1 and IN2 as long as a reverse voltage condition does not exist on that channel. To enable fast switchover on the TPS2121, CP2 needs to be higher than VREF, 1.06-V (typical). By using the external voltage reference control scheme (XREF), the voltages on PR1 and CP2 pins are compared to determine whether IN1 or IN2 is powering the output. If the voltage on PR1 is higher than CP2, then IN1 is powering the output. If the voltage on PR1 is lower than CP2, then IN2 is powering the output.

Manual switchover on the TPS2121 is configured by connecting PR1 to IN1 with a resistor divider, and connecting CP2 to the external 3.3-V MCU signal. If the voltage on CP2 is higher than the voltage on PR1, then IN2 will power the output. However, if CP2 is toggled low, then IN1 will power the output, assuming IN1 has a valid input voltage.

The diagram below shows the application schematic for this design example on the TPS2121.

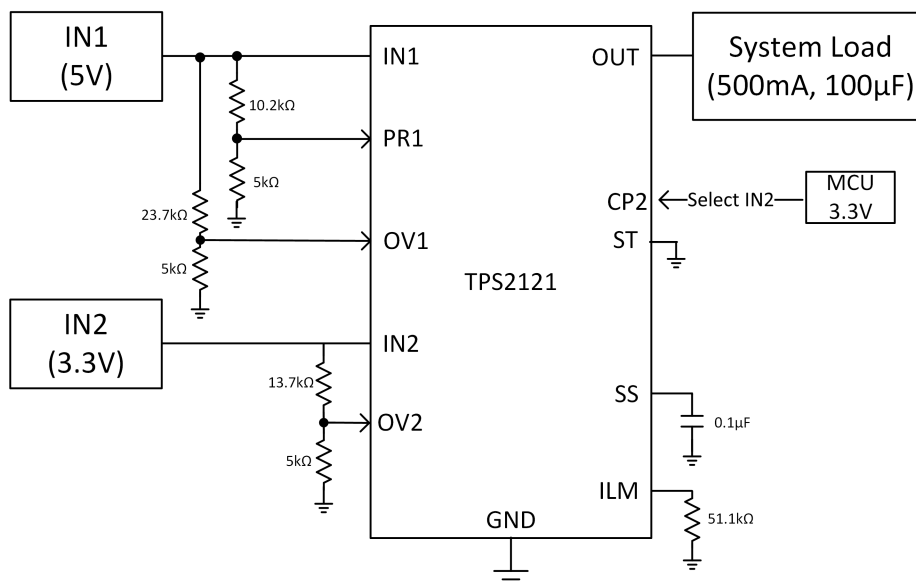

Figure 10-4. TPS2121 Manual Switchover

10.2.4 Design Procedure

10.2.4.1 Selecting PR1 and CP2 Resistors

The TPS2120 does not contain a CP2 pin. Instead, a select pin (SEL), enables override of the PR1 / VREF comparison. Once the voltage on SEL is greater than VREF, the device will select IN2 as the output. For manual switchover, an external signal can be connected to the SEL pin. For this example, the external MCU signal is a 3.3-V enable.

The TPS2121 can be configured for manual switchover in a similar manner as the TPS2120. Instead of a SEL pin, the 3.3-V external MCU signal can be connected to CP2. As long as the voltage on CP2 is higher than PR1, the device will select IN2 as the output. When the voltage on CP2 drops below PR1, the device will switch back to IN1. Therefore, the resistor divider on PR1 is configured the same as above, with the 5 kΩ and 10.2 kΩ.

For additional precautions, the voltage on PR1 can also be configured. If the voltage on IN1 were to drop, the device can automatically switchover to IN2. In this example, if voltage on IN1 drops below IN2 (3.3 V) then the device will switch to IN2. Therefore, the resistor divider on PR1 should be configured such that the voltage on PR1 will drop below VREF, when IN1 dips below 3.3 V. The bottom resistor is chosen to be 5 kΩ due to its commonality and minimal current leakage. If a smaller leakage is desired, a larger resistor can be used. With this configuration, the top resistor was selected to be 10.2 kΩ. With this resistor configuration, the device will switch to IN2 when the voltage on IN1 dips to 3.22 V. Refer to [Table 9-2](#) for additional information regarding the switchover configuration.

See [Equation 5](#) for the VPR1 Calculation

$$V_{PR1} = V_{IN1} \times \frac{5 \text{ k}\Omega}{5 \text{ k}\Omega + 10.2 \text{ k}\Omega}$$

$$1.06 \text{ V} = V_{IN1} \times \frac{5 \text{ k}\Omega}{5 \text{ k}\Omega + 10.2 \text{ k}\Omega} = 3.22 \text{ V} \quad (5)$$

10.2.4.2 Selecting OVx Resistors

Independent output overvoltage protection is available for both IN1 and IN2. The VREF comparator on the OV1 and OV2 pins allows for the overvoltage protection thresholds to be adjusted independently, allowing for different overvoltage thresholds on each channel. When overvoltage is engaged, the corresponding channel will turn off immediately if the pin reaches VREF, 1.06 V (typical). On this design, the overvoltage thresholds are triggered at roughly 1-V higher than the nominal input voltages. On IN1, the overvoltage resistor divider was programmed to be 6.08 V, where as the divider on IN2 was programmed to be 3.96 V. The OV resistor calculations are shown in [Equation 6](#) and [Equation 7](#).

$$1.06 \text{ V} = V_{IN1} \times \left(\frac{5 \text{ k}\Omega}{5 \text{ k}\Omega + 23.7 \text{ k}\Omega} \right) = 6.08 \text{ V} \quad (6)$$

$$1.06 \text{ V} = V_{IN2} \times \left(\frac{5 \text{ k}\Omega}{5 \text{ k}\Omega + 13.7 \text{ k}\Omega} \right) = 3.96 \text{ V} \quad (7)$$

10.2.4.3 Selecting Soft-Start Capacitor and Current Limit Resistors

[Equation 1](#) can be used to determine the RLIM values for this application. In this example, the DC load current is 1 A. Setting the current limit to 2 A will limit potential inrush current events and protect downstream loads. See [Equation 8](#) for the TPS2120 ILM Calculation:

$$I_{LM} = \frac{69.1}{59^{0.861}} = 2.06 \text{ A} \quad (8)$$

See [Equation 9](#) for the TPS2121 ILM Calculation:

$$I_{LM} = \frac{65.2}{59^{0.861}} = 1.95 \text{ A} \quad (9)$$

To calculate the slew rate needed to limit the inrush current to 100 mA, the Slew Rate Calculation can be used in [Equation 10](#):

$$SR_{ON} = \frac{I_{INRUSH}}{C_L} \quad (10)$$

$$SR_{ON} = \frac{100 \text{ mA}}{100 \mu\text{F}} = 1000 \text{ V / S} \quad (11)$$

Using this equation, the slew rate must be limited to 1000V/S or below to keep the inrush current below 100 mA. According to [Table 9-1](#), at 5 V a CSS capacitance of 100 nF will provide a slew rate of 780V/S (typical), which is below the calculated threshold of 1000V/S. Therefore, a 100 nF capacitor will limit the inrush below 100 mA in a typical application.

10.2.5 Application Curves

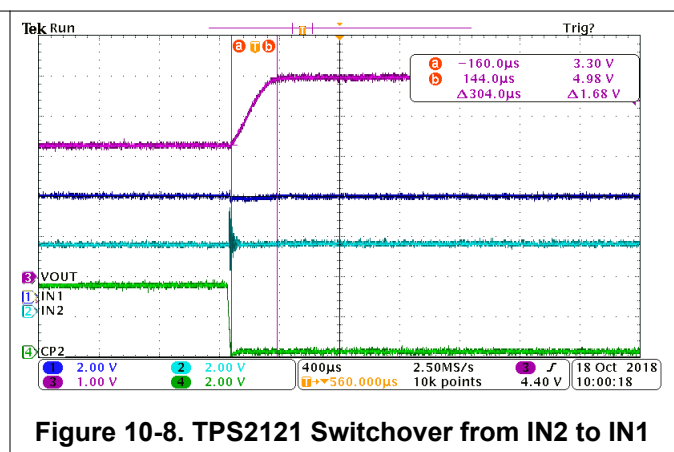
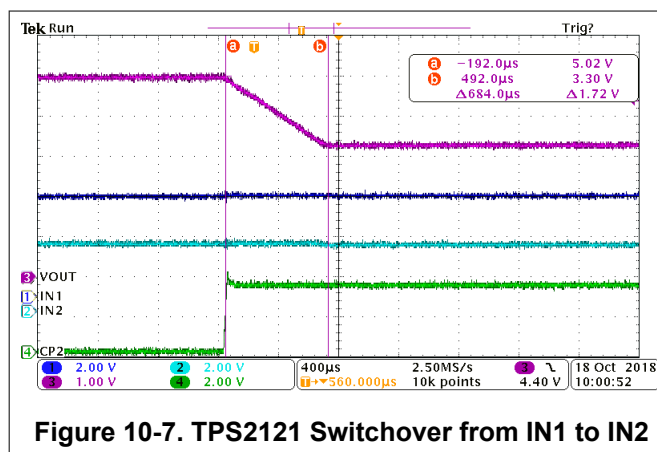
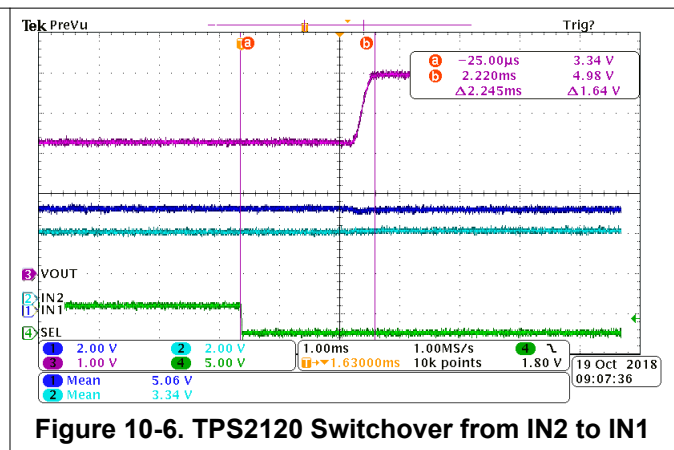
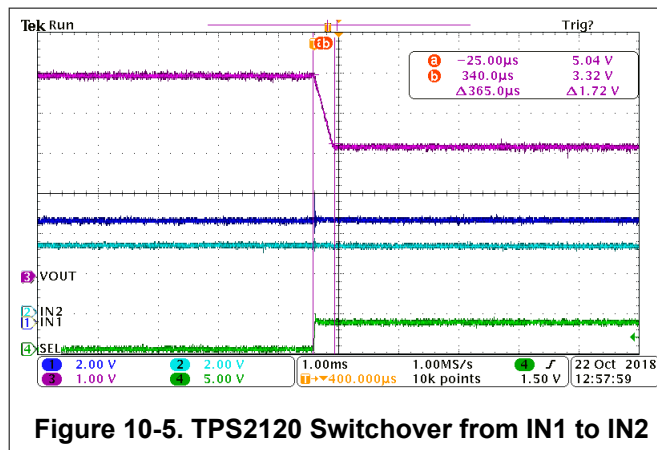

10.3 Automatic Switchover with Priority (XCOMP)

In certain applications, the system needs to provide uninterrupted sources of power. If one of the input power supplies were to fail, the system needs to automatically switchover to a backup power source without interrupting normal operation. In this example, two scenarios will be demonstrated. The first example will prioritize a 12-V main supply, and switchover to a 5-V auxiliary supply whenever the 12 V is not present. The second example will showcase power redundancy with two 12-V supplies. If one 12-V supply were to fail, the device will seamlessly switchover to the backup supply.

10.3.1 Application Schematic

Figure 10-9 shows the application schematic for automatic switchover on the TPS2121 between a 12-V and 5-V supply.

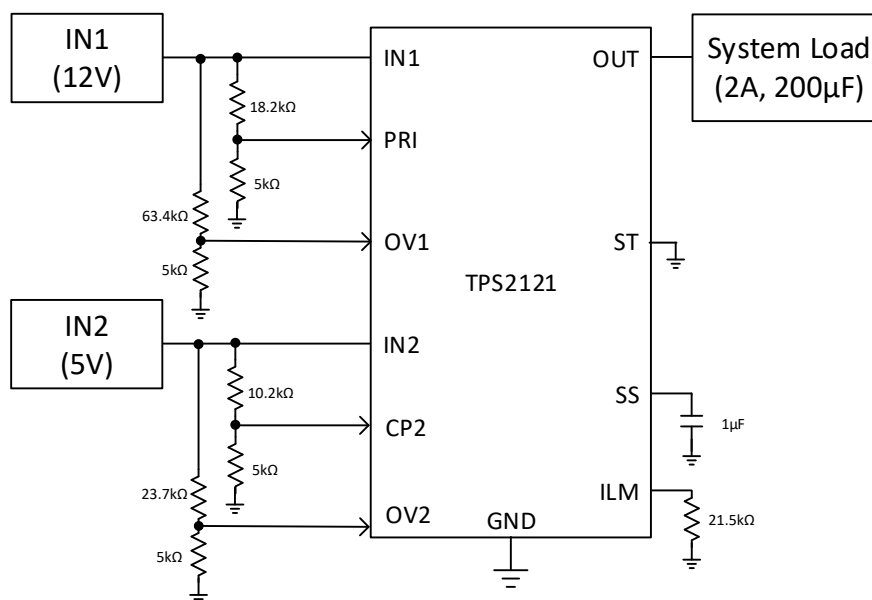

Figure 10-9. Automatic Switchover Between 12 V and 5 V

10.3.2 Design Requirements

Table 10-3. Automatic Switchover Design Requirements

DESIGN PARAMETER	SPECIFICATION	DETAILS
IN1 Voltage	V_{IN1}	12 V
IN2 Voltage	V_{IN1}	5 V
Load Current	I_{OUT}	2 A
Load Capacitance	C_L	200 μ F
Maximum Inrush Current	I_{INRUSH}	100 mA
Switchover Time	t_{SW}	TPS2120: 5 μ s
Mode of Operation	Automatic Switchover	TPS2121: XCOMP

10.3.3 Detailed Design Description

The first example demonstrates automatic switchover from main power (IN1) to standby power (IN2). This architecture is commonly found on applications that require a secondary/auxiliary input to conserve power while keeping downstream loads on. When switching between main and auxiliary power, the voltage drop on the output should also be minimal to prevent the downstream load from resetting or entering a lockout condition.

In this first example, the system is prioritizing the 12-V main supply on IN1. When the 12-V supply drops below 7.6 V, the device will automatically switch to the 5-V auxiliary supply on IN2. When the 12-V supply returns, it will

become the output supply again. Furthermore, the voltage drop on the output should be minimal, providing the output with uninterrupted redundant power.

To minimize the voltage dip on the output, the TPS2121 will be used in fast switchover mode. By configuring the device in external comparator control scheme (XCOMP), the voltages on PR1 and CP2 are compared to determine whether IN1 or IN2 is powering the output. However, unlike the XREF mode, described above in the manual switchover configuration, XCOMP does not connect an external GPIO signal to the CP2 pin. Instead, PR1 and CP2 are connected to IN1 and IN2 respectively, allowing a direct voltage comparison between the two input channels. PR1 and CP2 are connected to IN1 and IN2 with a resistor divider. If the voltage on CP2 is higher than the voltage on PR1, then IN2 will power the output. If the voltage on PR1 is higher than the voltage on CP2, then IN1 will power the output.

10.3.4 Design Procedure

10.3.4.1 Selecting PR1 and CP2 Resistors

In this example, the device will switch from IN1 to IN2 when the voltage on IN1 drops below 7.6 V. Therefore, the voltage on PR1 needs to remain higher than the voltage on CP2 until this condition exists.

Since this example was tested on the TPS2121EVM, the resistor divider configured the voltage on CP2 to be 1.644 V.

See [Equation 12](#) for the VCP2 Calculation

$$V_{CP2} = 5 \text{ V} \times \frac{5 \text{ k}\Omega}{5 \text{ k}\Omega + 10.2 \text{ k}\Omega} = 1.64 \text{ V} \quad (12)$$

Since the voltage on CP2 is higher than VREF, fast switchover mode is enabled.

Next, to calculate the necessary resistor divider on PR1, the voltage on PR1 needs to drop below 1.64 V when IN1 reaches 7.6 V. On the EVM, the PR1 resistors were configured as followed:

See [Equation 13](#) for the VPR1 Calculation

$$V_{PR1} = 12 \text{ V} \times \frac{5 \text{ k}\Omega}{5 \text{ k}\Omega + 18.2 \text{ k}\Omega} = 2.59 \text{ V}$$

$$1.64 \text{ V} = V_{SW} \times \frac{5 \text{ k}\Omega}{5 \text{ k}\Omega + 18.2 \text{ k}\Omega} = 7.6 \text{ V} \quad (13)$$

10.3.5 Application Curves

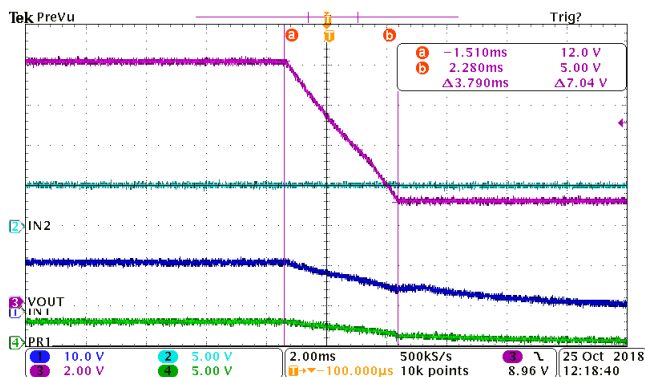

Figure 10-10. Automatic Switchover from IN1 to IN2

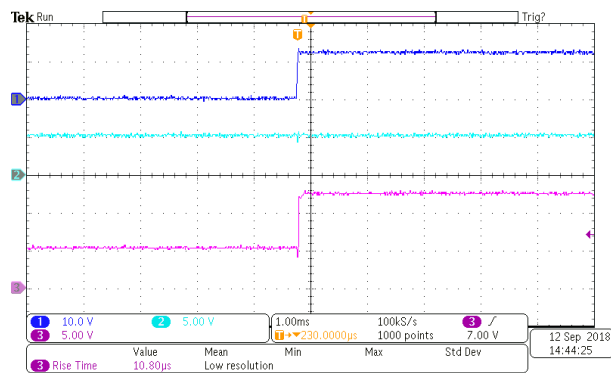

Figure 10-11. Automatic Switchover from IN2 to IN1

10.4 Automatic Seamless Switchover with Priority (XREF)

In this second automatic switchover example, the application design will showcase power redundancy with two 12-V supplies. If one 12-V supply were to fail, the device will seamlessly switchover to the backup supply.

10.4.1 Application Schematic

Figure 10-12 shows the application schematic for automatic switchover with redundant supplies on the TPS2121.

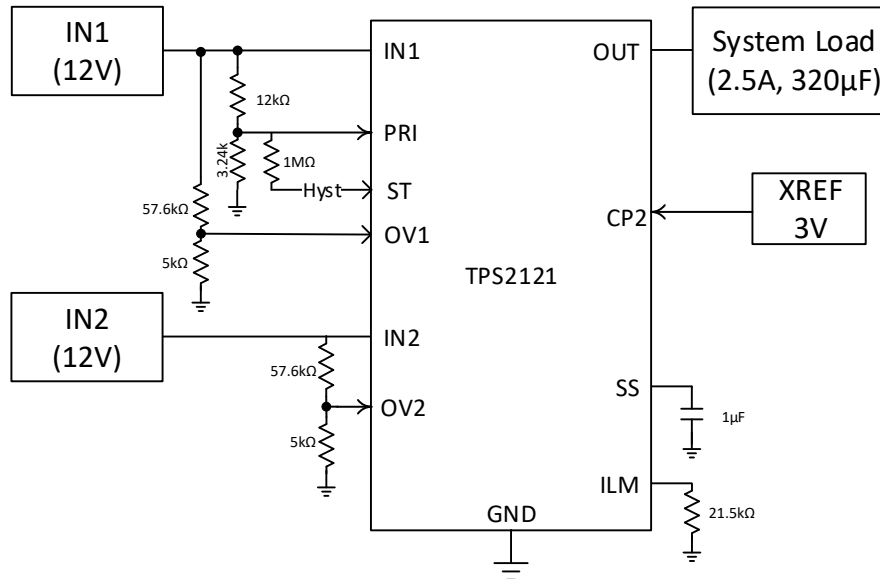

Figure 10-12. Automatic Switchover Between Two 12-V Supplies

10.4.2 Design Requirements

Table 10-4. Automatic Switchover Design Requirements

DESIGN PARAMETER	SPECIFICATION	DETAILS
Input Voltage Range	V_{IN1}, V_{IN2}	12.1 V \pm 3%
Output Voltage Range	V_{OUT}	12 V \pm 5%
Load Current	I_{OUT}	2.5 A
Load Capacitance	C_L	320 μ F
Switchover Time	t_{SW}	TPS2120: 5 μ s
Mode of Operation	Automatic Switchover	TPS2121: XREF

10.4.3 Detailed Design Description

In the second example, the system seamlessly switches between two 12-V supplies, providing uninterrupted power to a downstream load. Priority is given to IN1, the main 12-V power rail, and switches over to IN2, the backup 12-V power rail, whenever IN1 dips. When the main power rail returns, the device will switch back to the main supply. Redundant power is critical in systems that require uninterrupted sources of power. If the output voltage were to dip on these systems, this could cause the downstream load to reset to enter an undervoltage lockout condition. Therefore, the TPS2121 will be used in fast switchover mode to minimize the output voltage dip.

Similar to the automatic switchover example shown above, the TPS2121 can be configured in XCOMP mode. However, to minimize the voltage switchover error for a more seamless switchover, an external precision regulator can be connected to CP2 in XREF mode. In this configuration, a REF3325 provides an external reference voltage on 2.5 V \pm 0.15% (2.50375V). If the voltage on PR1 is higher than this external reference, priority will be given to IN1. If the voltage on PR1 drops below 2.50375V, then the device will switchover to IN2.

The design specifications detail the input voltage range for $12.1 \pm 3\%$. Therefore, the resistor divider on PR1 is configured such that the voltage on the pin dips below 2.50375V before IN1 crosses 11.73 V ($12.1 \text{ V} - 3\%$). Once this occurs, the design will start fast switchover to IN2 within 5 us.

For additional information regarding this configuration, including full design procedures, schematics, and layout, please refer to [TIDA-01638: Seamless Switchover for Backup Power Reference Design](#).

10.4.4 Application Curves

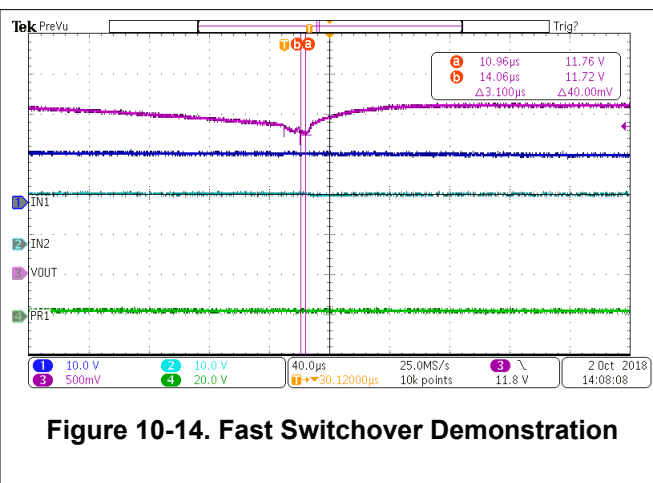
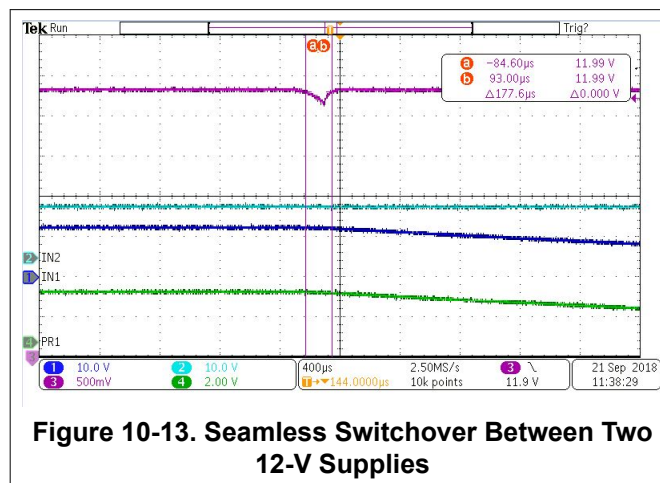

10.5 Highest Voltage Operation (VCOMP)

10.5.1 Application Schematic

Figure 10-15 shows the application schematic for highest voltage operation on the TPS2121. The same configuration can be completed on the TPS2120, with the SEL pin connected to GND instead of the CP2 pin.

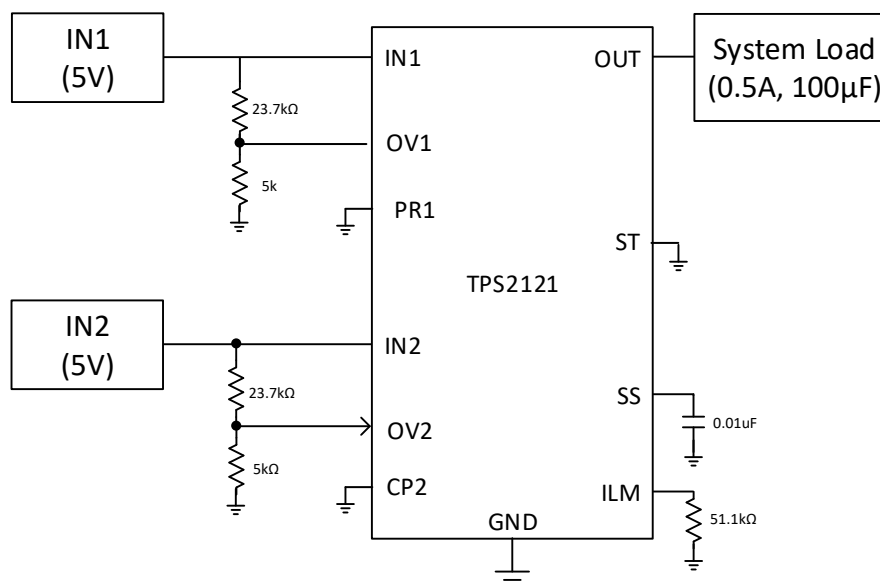

Figure 10-15. Highest Voltage Operation

10.5.2 Design Requirements

Table 10-5. Highest Voltage Design Requirements

DESIGN PARAMETER	SPECIFICATION	DETAILS
Input Voltage	V_{IN1}, V_{IN2}	5 V
Output Voltage	V_{OUT}	5 V
Load Current	I_{OUT}	0.5 A
Load Capacitance	C_L	100 μ F
Switchover Time	t_{SW}	TPS2121: 100 μ s
Mode of Operation	Automatic Switchover	TPS2121: VCOMP

10.5.3 Detailed Design Description

In this mode of operation, the device will use an internal comparator between the two inputs to determine the priority source. If both PR1 and CP2 are below V_{REF} , priority is given to the highest input voltage. If both of the inputs voltages are equal, V_{COMP} and hysteresis ensures that IN2 takes priority. If IN2 falls below the V_{COMP} hysteresis, then IN1 will have priority. If IN2 gets reapplied, it will take priority when it falls within V_{COMP} of IN1.

In this example, the TPS2120 is configured with two 5-V inputs. When IN2 is applied to the system, it takes priority over IN1. Once it gets removed, priority returns to IN1.

10.5.4 Detailed Design Procedure

See Table 9-2 to summarize the priority between IN1 and IN2. Once IN2 reaches within V_{COMP} of IN1, the TPS2120 will switchover to IN2. Since IN1 is 5 V, once IN2 reaches 4.7 V ($5\text{ V} - 300\text{ mV}$), typically, the device will switch over to IN2. On the falling transition, once IN2 drops below V_{COMP} of IN1, the added hysteresis will prevent the device from switching back to IN1. Once IN2 drops below V_{COMP} and the hysteresis (3.5% typical), the device will switch. Therefore, the device will switch back to IN1 once IN1 reaches ($5\text{ V} - 300\text{ mV} - 175\text{ mV}$), 4.525 V.

10.5.5 Application Curves

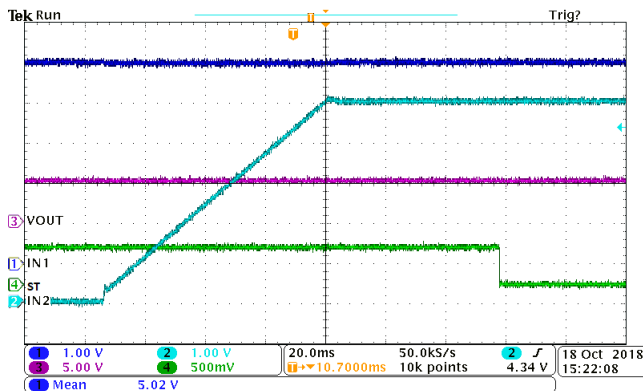

Figure 10-16. Switchover from IN1 to IN2

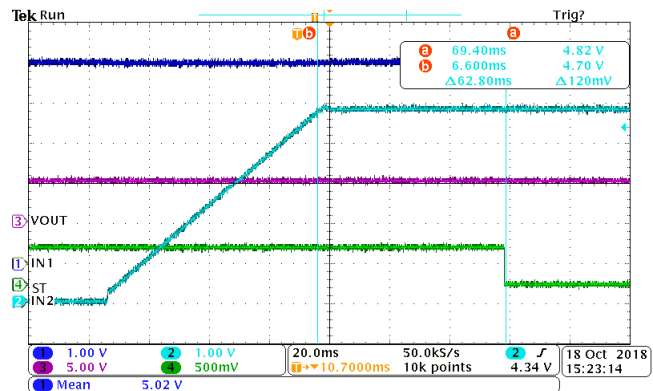

Figure 10-17. Timing from IN1 to IN2

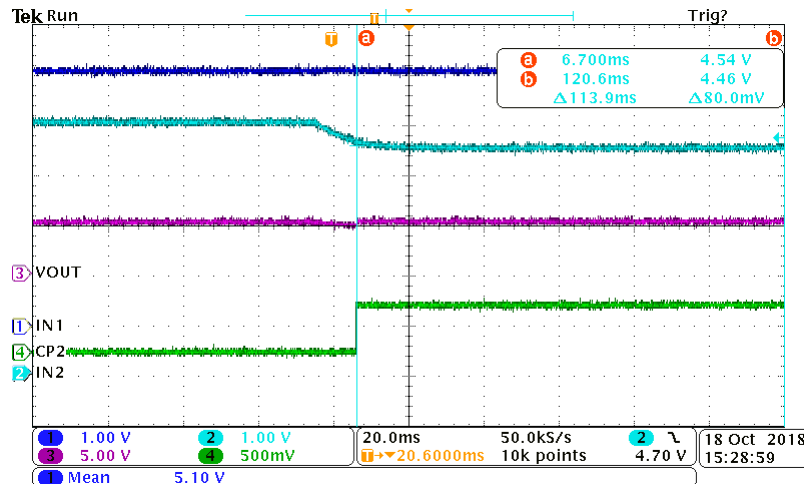

Figure 10-18. Switchover from IN2 to IN1

10.6 Reverse Polarity Protection with TPS212x

For applications that require reverse polarity protection, the TPS212x can be configured to protect against mis-wiring input power supplies and block reverse current that could potentially damage the system. By connecting a diode on the GND pin of the TPS212x, this prevents reverse current from flowing back into the device when VIN is below system ground.

Since the TPS212x has an absolute maximum rating of 24 V when referenced to device ground, the GND diode should be rated to standoff voltages up to the maximum reverse voltage. Furthermore, since the control pin voltages (PR1, OV1, OV2, etc.) are in reference to system GND, the voltage thresholds will need to be recalculated based on the voltage drop across the diode. To reduce the voltage drop, a resistor in parallel with the diode can also be used.

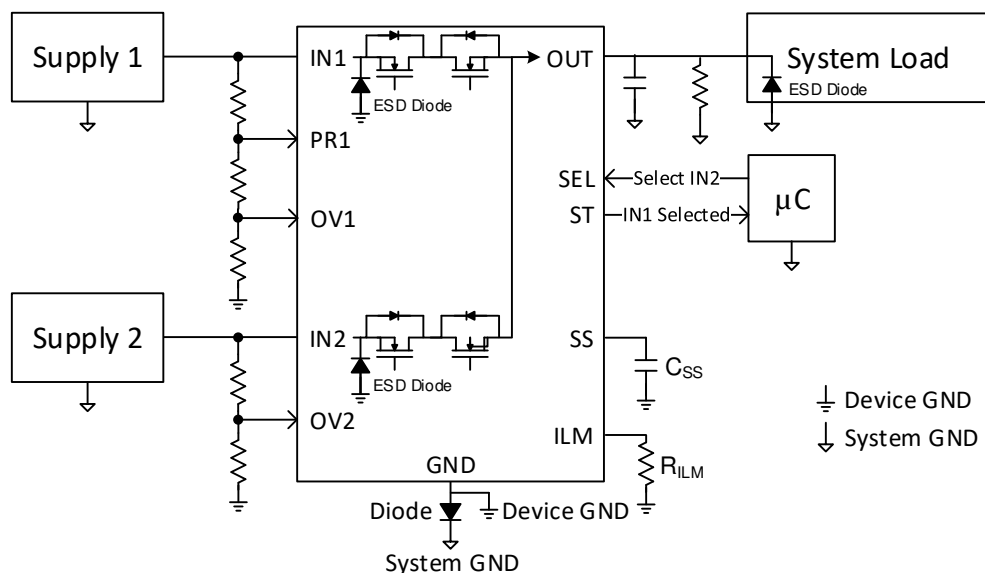

Figure 10-19. TPS212x Reverse Polarity Configuration

10.7 Hotplugging with TPS212x

Some applications require power muxing between hotplugged inputs, such as USB applications or systems with secondary supplies coming from a long cable. During a hot plug event, the inherent inductance in the cable and input traces can cause a voltage spike on the input pin ($V = L_{CABLE} \cdot di / dt$). This can cause a voltage spike on the input of the TPS212x that could potentially exceed the absolute maximum rating.

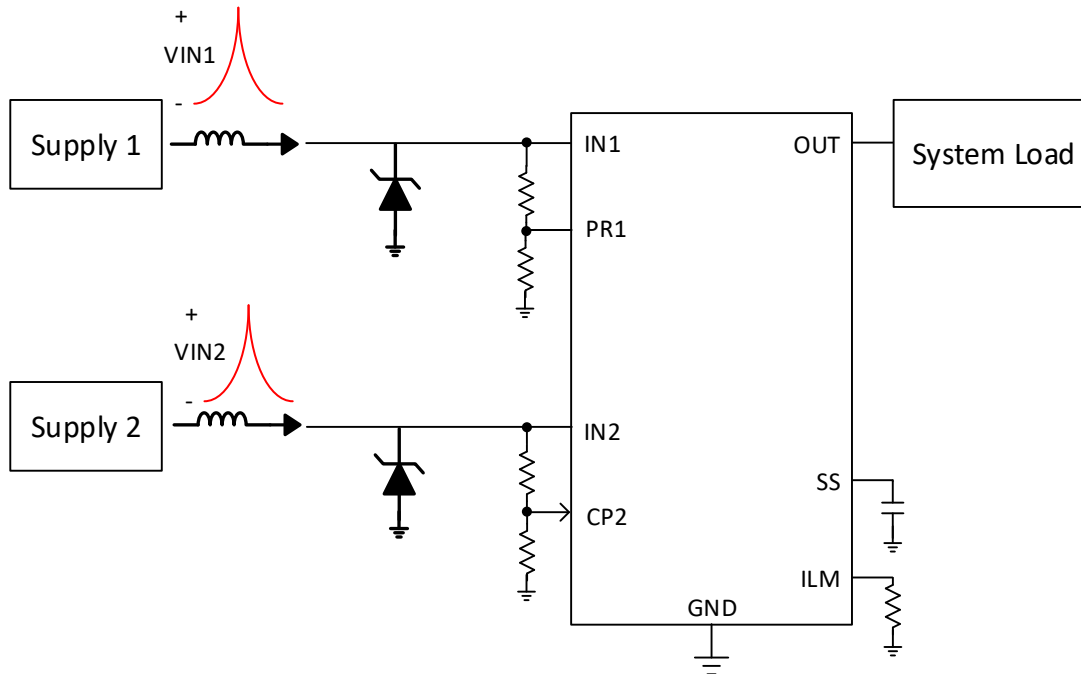

Figure 10-20. TPS212x Hotplug Configuration

Figure 10-21 shows a hotplug event where a 12-V supply is connected to the TPS212x through a 15ft cable. Without an external TVS, the input voltage spikes to over 30 V. To protect against this voltage transient, a clamping device such as a TVS (Transient Voltage Suppression) diode can be used. As shown in Figure 10-22, by using the TVS1800, the same voltage spike was clamped to 19.3 V.

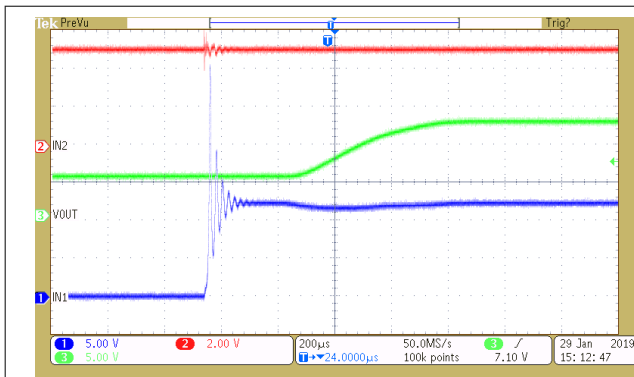

Figure 10-21. TPS2121 Hotplug Event without TVS

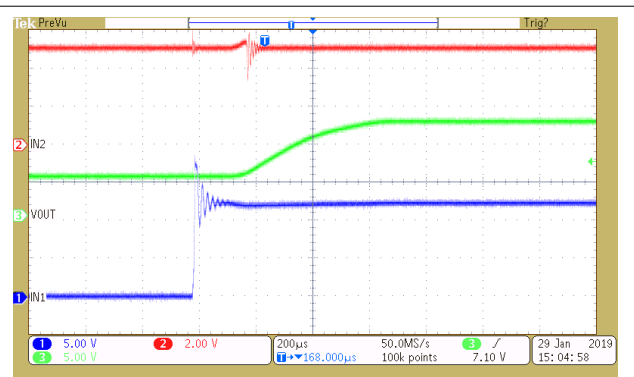

Figure 10-22. TPS2121 Hotplug Event with TVS1800

11 Power Supply Recommendations

IN1, IN2, and OUT traces should all be wide enough to accommodate the amount of current passing through the device. Bypass capacitors on these pins should be placed as close to the device as possible. Low ESR ceramic capacitors with X5R or X7R dielectric are recommended.

To avoid output voltage drop, the capacitance on OUT can be increased. If the power supply cannot handle the inrush current transients due to the output capacitance, a higher input capacitance can be used. In the case where there are long cables or wires connected to the input of the device, there may be ringing on the supply, especially during the fast switchover of the TPS2121. To help nullify the inductance of the cables and prevent ringing, a large capacitance can be used near the input of the device.

12 Layout

12.1 Layout Guidelines

Use short wide traces for input and output planes. For high current applications place vias under input and output pins to avoid current density and thermal resistance bottlenecks.

12.2 Layout Example

The example layout for the TPS2121 shows where to place vias for better thermal dissipation. This can improve the junction-to-ambient thermal resistance ($R_{\theta JA}$).

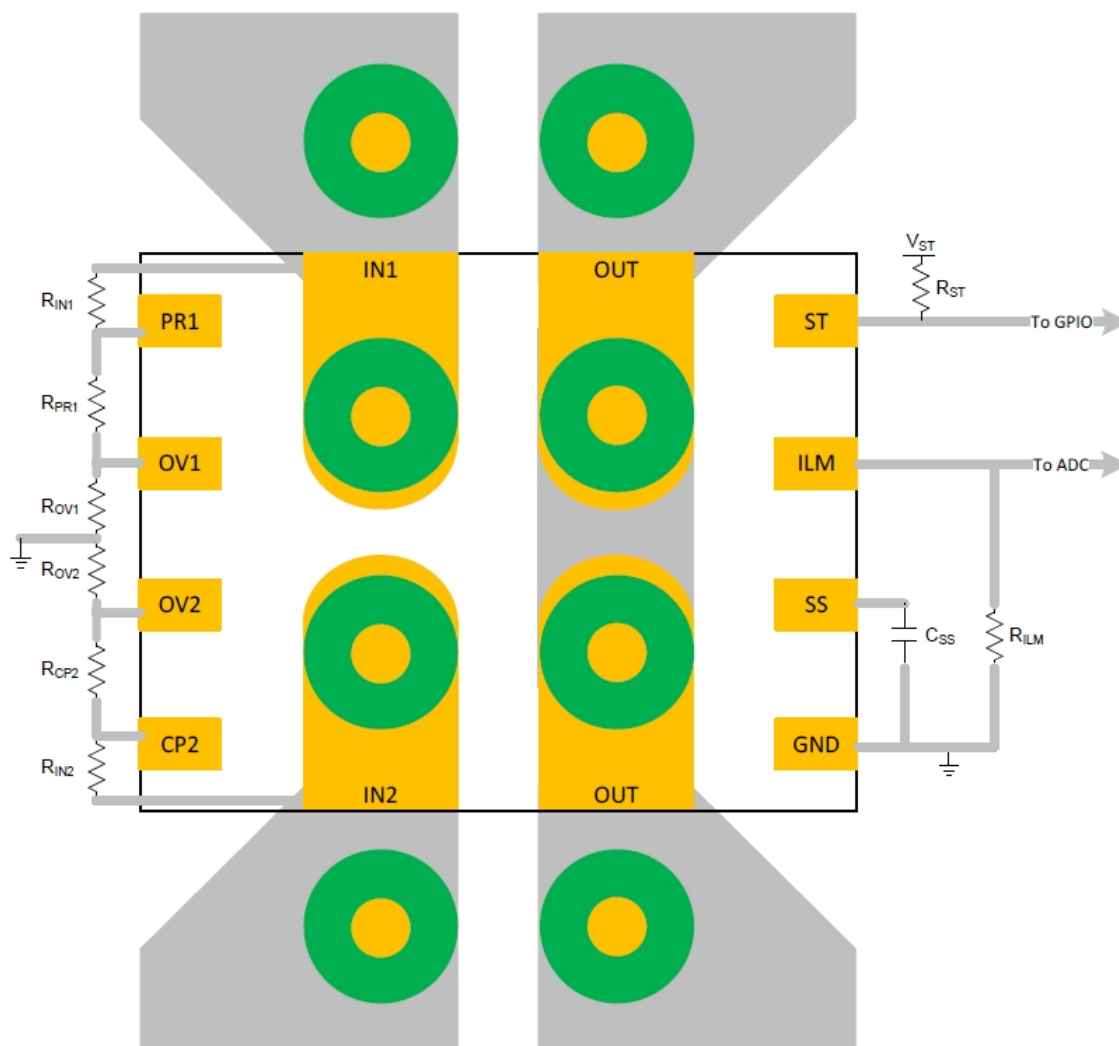

13 Device and Documentation Support

13.1 Documentation Support

13.1.1 Related Links

The table below lists quick access links. Categories include technical documents, support and community resources, tools and software, and quick access to order now.

Table 13-1. Related Links

PARTS	PRODUCT FOLDER	ORDER NOW	TECHNICAL DOCUMENTS	TOOLS & SOFTWARE	SUPPORT & COMMUNITY
TPS2120	Click here	Click here	Click here	Click here	Click here
TPS2121	Click here	Click here	Click here	Click here	Click here

13.2 Receiving Notification of Documentation Updates

To receive notification of documentation updates, navigate to the device product folder on ti.com. Click on *Subscribe to updates* to register and receive a weekly digest of any product information that has changed. For change details, review the revision history included in any revised document.

13.3 Support Resources

[TI E2E™ support forums](#) are an engineer's go-to source for fast, verified answers and design help — straight from the experts. Search existing answers or ask your own question to get the quick design help you need.

Linked content is provided "AS IS" by the respective contributors. They do not constitute TI specifications and do not necessarily reflect TI's views; see TI's [Terms of Use](#).

13.4 Trademarks

TI E2E™ is a trademark of Texas Instruments.

All other trademarks are the property of their respective owners.

13.5 Electrostatic Discharge Caution



This integrated circuit can be damaged by ESD. Texas Instruments recommends that all integrated circuits be handled with appropriate precautions. Failure to observe proper handling and installation procedures can cause damage.

ESD damage can range from subtle performance degradation to complete device failure. Precision integrated circuits may be more susceptible to damage because very small parametric changes could cause the device not to meet its published specifications.

13.6 Glossary

[TI Glossary](#) This glossary lists and explains terms, acronyms, and definitions.

14 Mechanical, Packaging, and Orderable Information

The following pages include mechanical, packaging, and orderable information. This information is the most current data available for the designated devices. This data is subject to change without notice and revision of this document. For browser-based versions of this data sheet, refer to the left-hand navigation.



YFP0020-C01

PACKAGE OUTLINE

DSBGA - 0.5 mm max height

DIE SIZE BALL GRID ARRAY

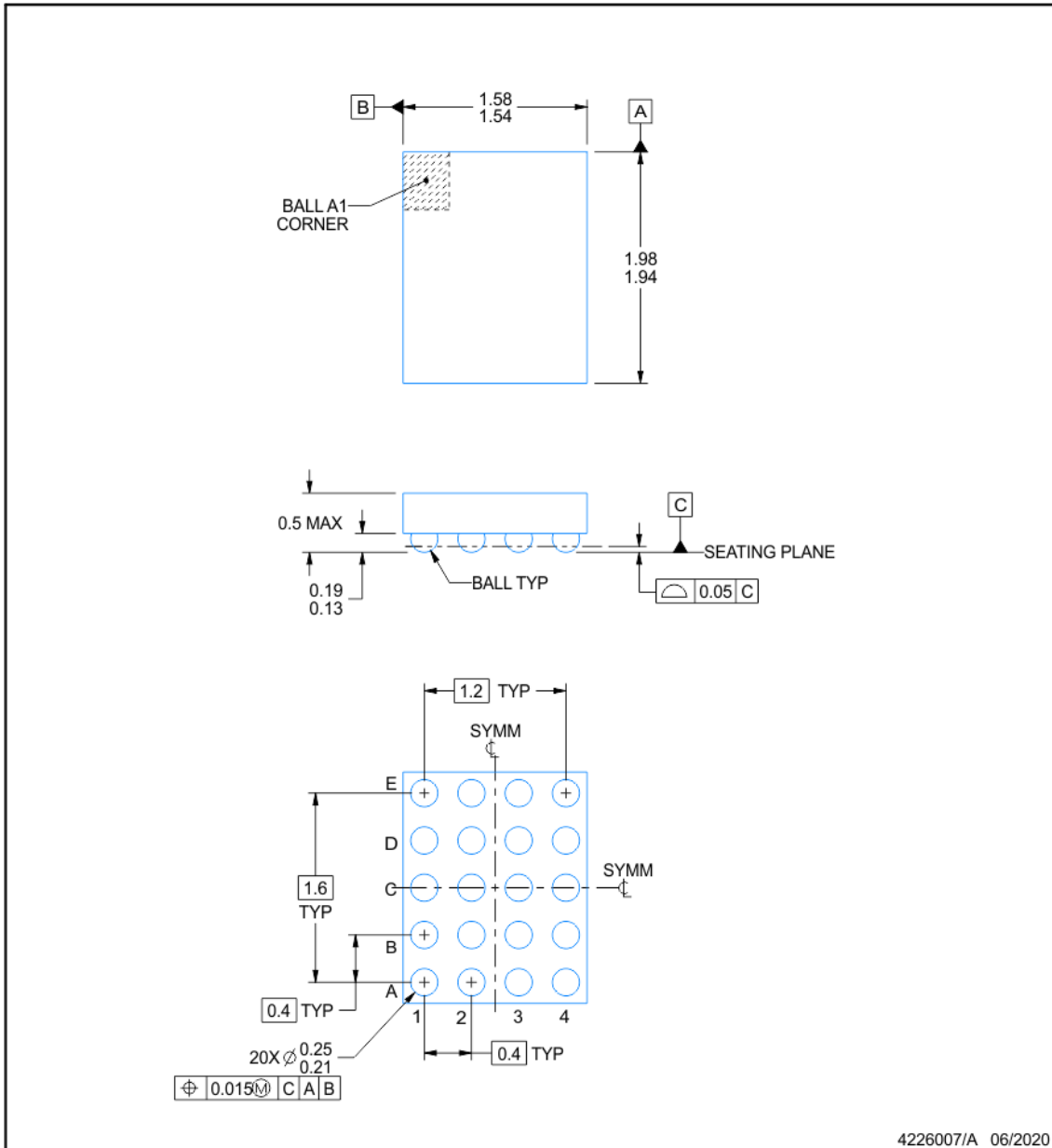

NOTES:

1. All linear dimensions are in millimeters. Any dimensions in parenthesis are for reference only. Dimensioning and tolerancing per ASME Y14.5M.
2. This drawing is subject to change without notice.

EXAMPLE BOARD LAYOUT

YFP0020-C01

DSBGA - 0.5 mm max height

DIE SIZE BALL GRID ARRAY

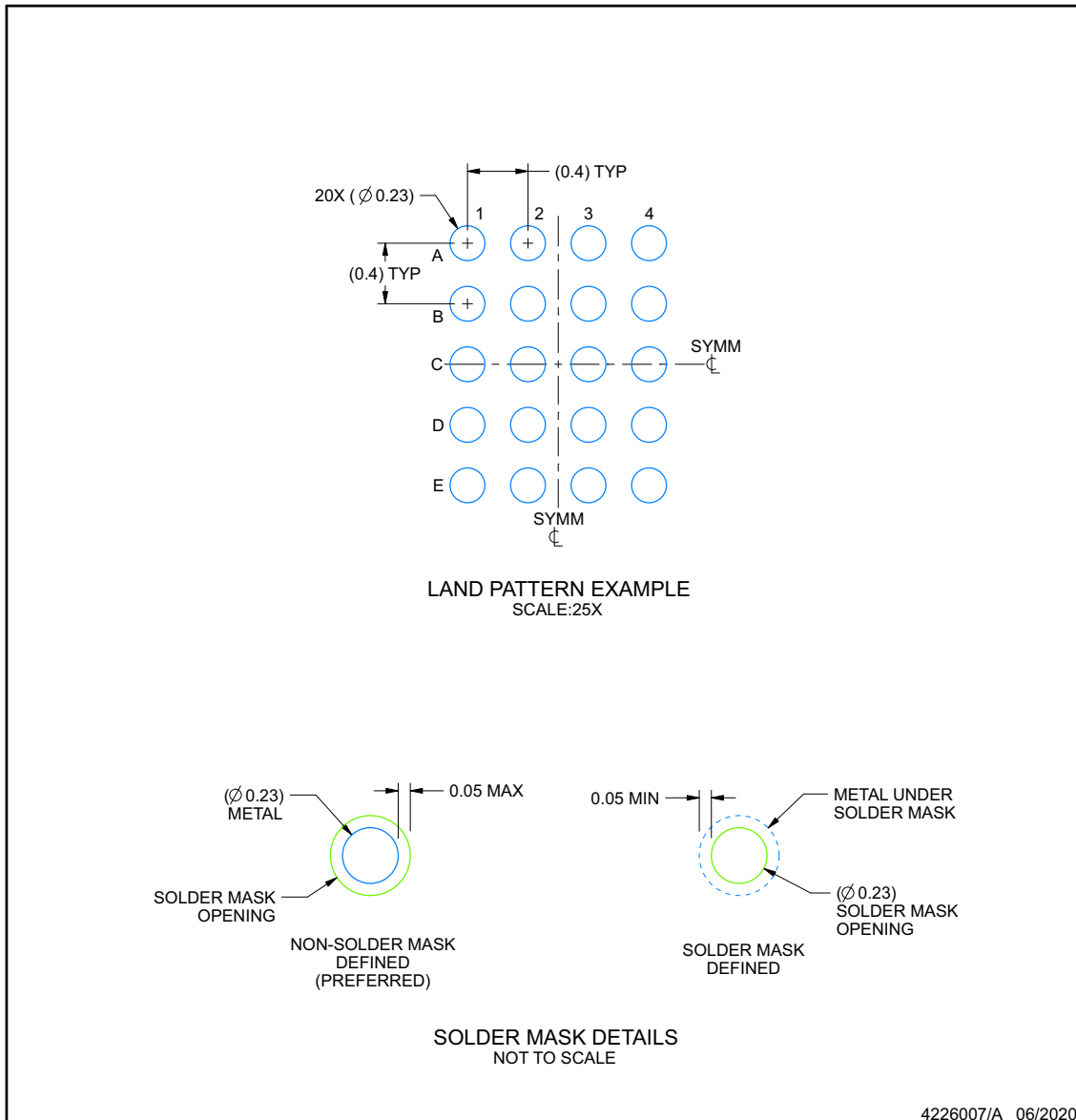

NOTES: (continued)

3. Final dimensions may vary due to manufacturing tolerance considerations and also routing constraints. For more information, see Texas Instruments literature number SNVA009 (www.ti.com/lit/snva009).

EXAMPLE STENCIL DESIGN

YFP0020-C01

DSBGA - 0.5 mm max height

DIE SIZE BALL GRID ARRAY

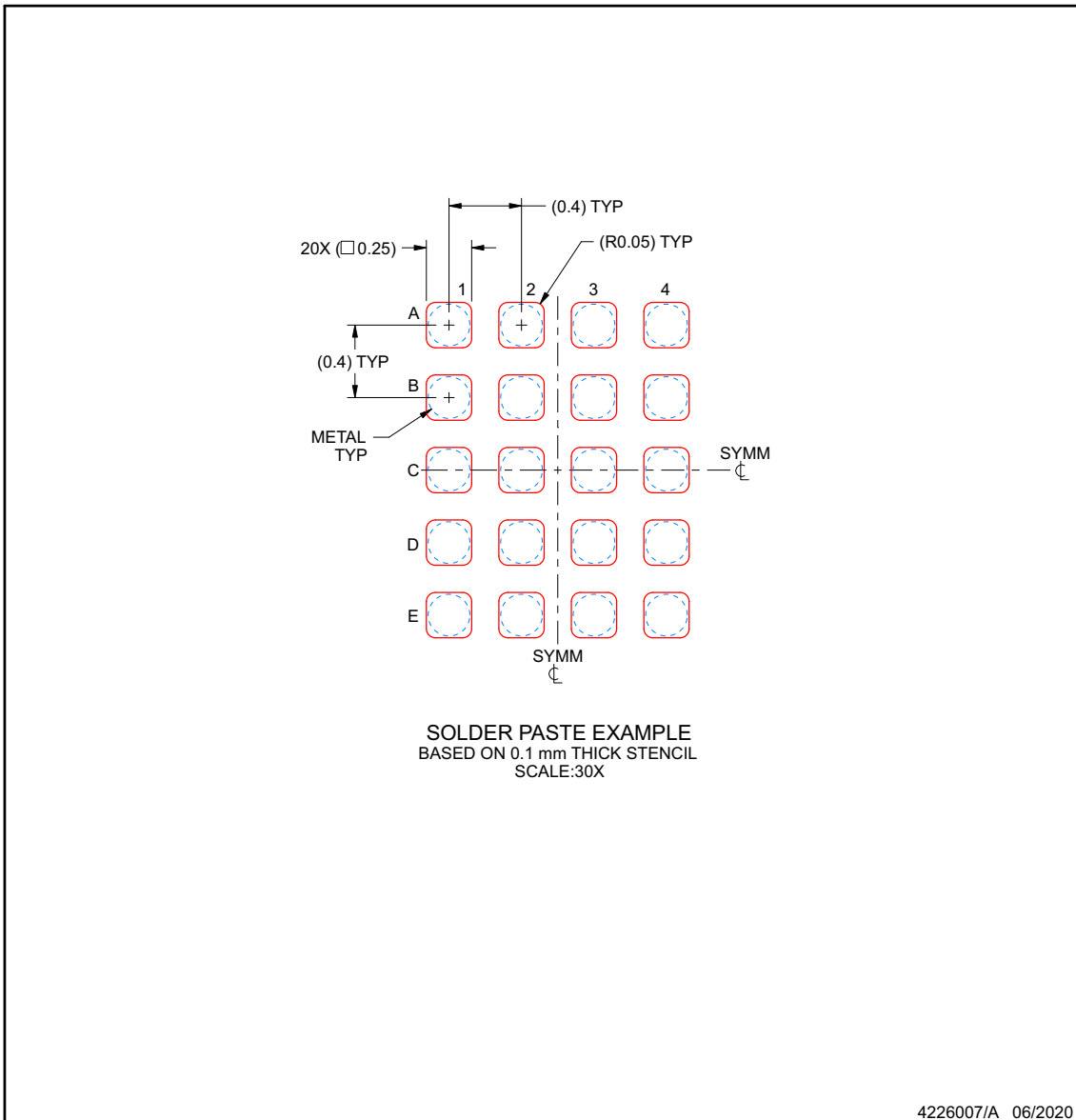

NOTES: (continued)

- 4. Laser cutting apertures with trapezoidal walls and rounded corners may offer better paste release.

EXAMPLE BOARD LAYOUT

VQFN-HR - 1 mm max height

RUX0012A

PLASTIC QUAD FLAT-NO LEAD

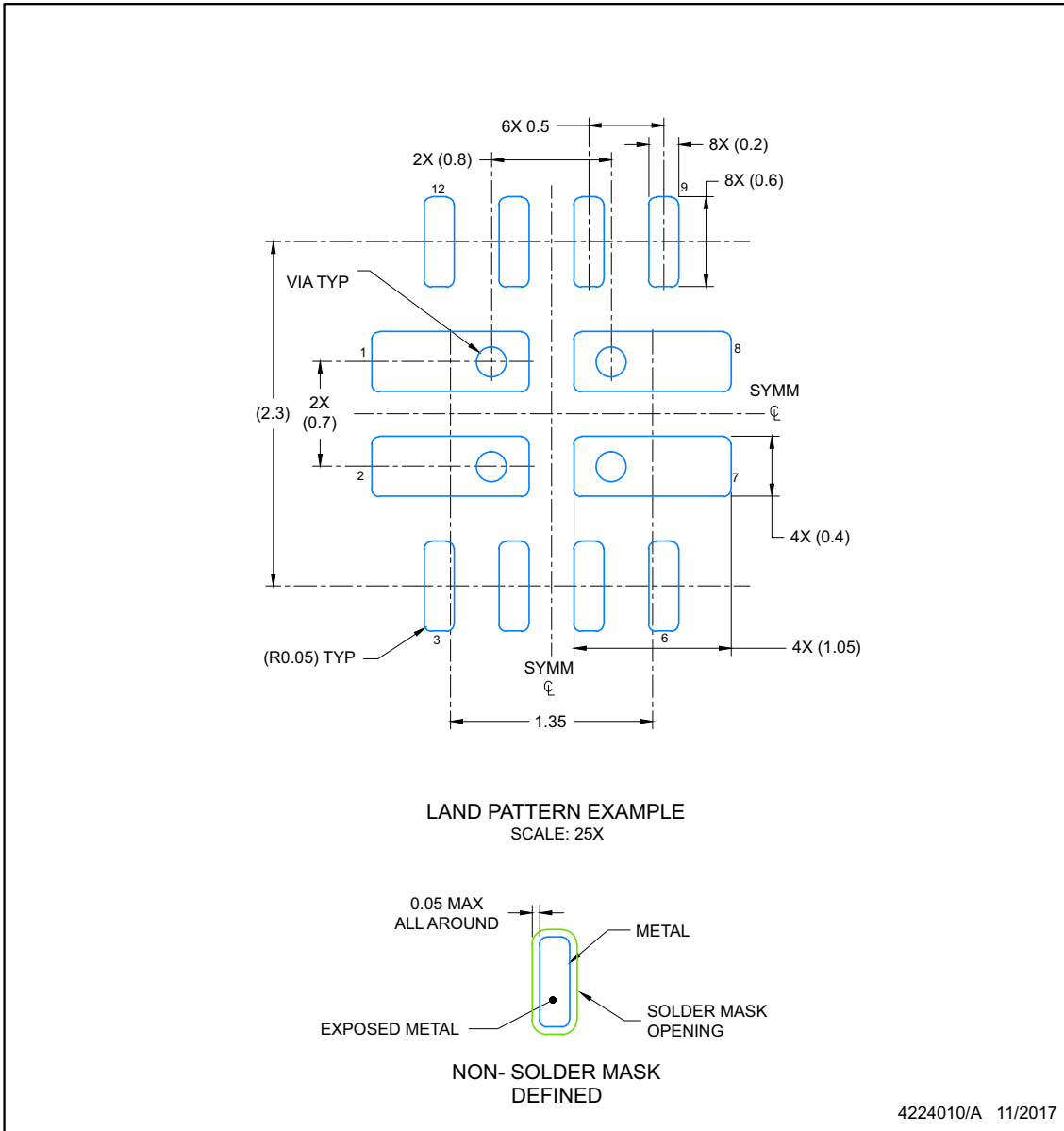

NOTES: (continued)

- For more information, see Texas Instruments literature number SLUA271 (www.ti.com/lit/slua271) .

EXAMPLE STENCIL DESIGN

RUX0012A

VQFN-HR - 1 mm max height

PLASTIC QUAD FLAT-NO LEAD

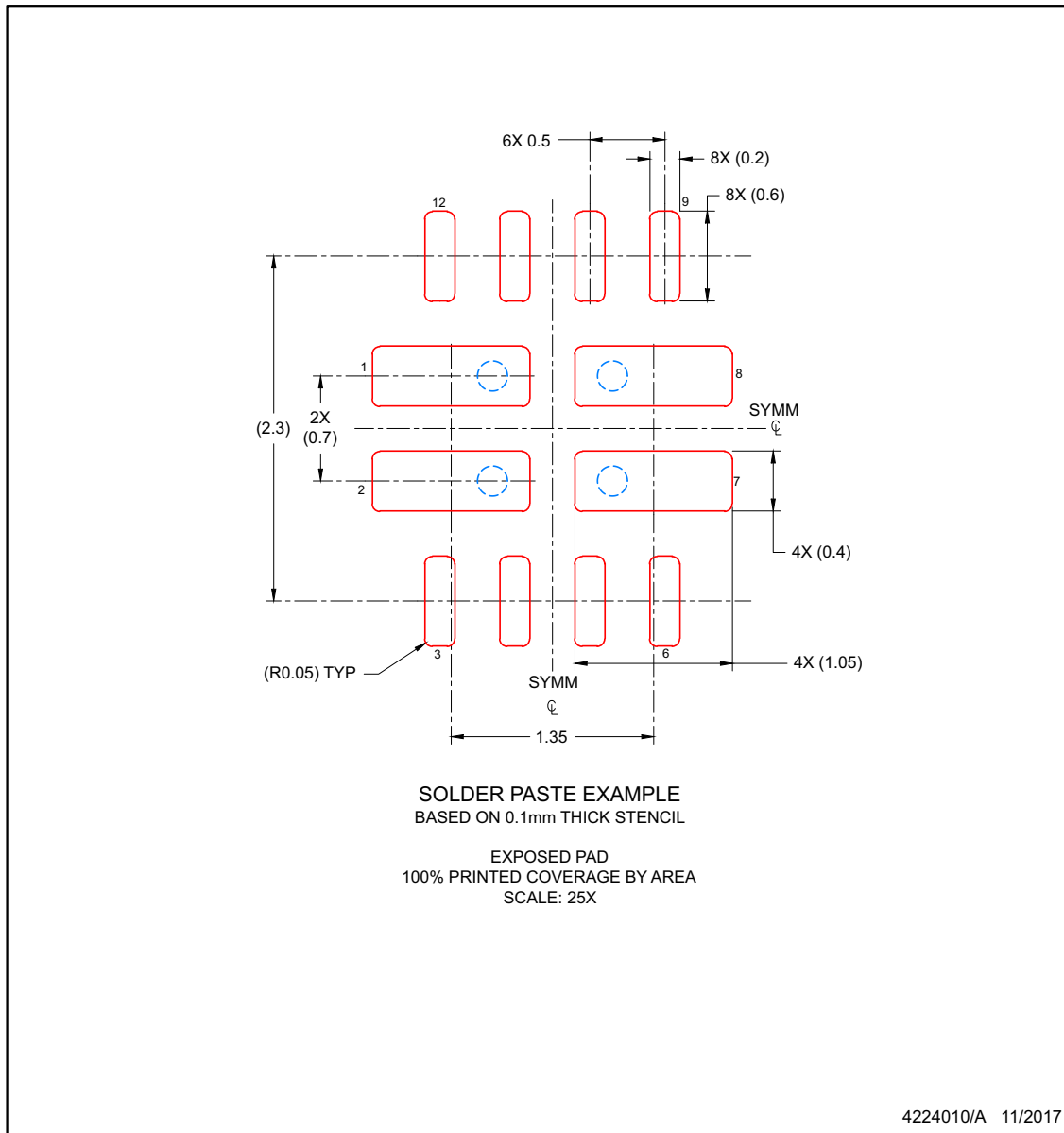

NOTES: (continued)

4. Laser cutting apertures with trapezoidal walls and rounded corners may offer better paste release. IPC-7525 may have alternate design recommendations.

PACKAGING INFORMATION

Orderable Device	Status (1)	Package Type	Package Drawing	Pins	Package Qty	Eco Plan (2)	Lead finish/ Ball material (6)	MSL Peak Temp (3)	Op Temp (°C)	Device Marking (4/5)	Samples
TPS2120YFPR	ACTIVE	DSBGA	YFP	20	3000	RoHS & Green	SAC396 SNAGCU	Level-1-260C-UNLIM	-40 to 125	20	Samples
TPS2120YFPT	ACTIVE	DSBGA	YFP	20	250	RoHS & Green	SAC396 SNAGCU	Level-1-260C-UNLIM	-40 to 125	20	Samples
TPS2121RUXR	ACTIVE	VQFN-HR	RUX	12	3000	RoHS & Green	Call TI NIPDAU	Level-1-260C-UNLIM	-40 to 125	2121	Samples
TPS2121RUXT	ACTIVE	VQFN-HR	RUX	12	250	RoHS & Green	Call TI NIPDAU	Level-1-260C-UNLIM	-40 to 125	2121	Samples

(1) The marketing status values are defined as follows:

ACTIVE: Product device recommended for new designs.

LIFEBUY: TI has announced that the device will be discontinued, and a lifetime-buy period is in effect.

NRND: Not recommended for new designs. Device is in production to support existing customers, but TI does not recommend using this part in a new design.

PREVIEW: Device has been announced but is not in production. Samples may or may not be available.

OBSELETE: TI has discontinued the production of the device.

(2) **RoHS:** TI defines "RoHS" to mean semiconductor products that are compliant with the current EU RoHS requirements for all 10 RoHS substances, including the requirement that RoHS substance do not exceed 0.1% by weight in homogeneous materials. Where designed to be soldered at high temperatures, "RoHS" products are suitable for use in specified lead-free processes. TI may reference these types of products as "Pb-Free".

RoHS Exempt: TI defines "RoHS Exempt" to mean products that contain lead but are compliant with EU RoHS pursuant to a specific EU RoHS exemption.

Green: TI defines "Green" to mean the content of Chlorine (Cl) and Bromine (Br) based flame retardants meet JS709B low halogen requirements of <=1000ppm threshold. Antimony trioxide based flame retardants must also meet the <=1000ppm threshold requirement.

(3) MSL, Peak Temp. - The Moisture Sensitivity Level rating according to the JEDEC industry standard classifications, and peak solder temperature.

(4) There may be additional marking, which relates to the logo, the lot trace code information, or the environmental category on the device.

(5) Multiple Device Markings will be inside parentheses. Only one Device Marking contained in parentheses and separated by a "-" will appear on a device. If a line is indented then it is a continuation of the previous line and the two combined represent the entire Device Marking for that device.

(6) Lead finish/Ball material - Orderable Devices may have multiple material finish options. Finish options are separated by a vertical ruled line. Lead finish/Ball material values may wrap to two lines if the finish value exceeds the maximum column width.

Important Information and Disclaimer:The information provided on this page represents TI's knowledge and belief as of the date that it is provided. TI bases its knowledge and belief on information provided by third parties, and makes no representation or warranty as to the accuracy of such information. Efforts are underway to better integrate information from third parties. TI has taken and

continues to take reasonable steps to provide representative and accurate information but may not have conducted destructive testing or chemical analysis on incoming materials and chemicals. TI and TI suppliers consider certain information to be proprietary, and thus CAS numbers and other limited information may not be available for release.

In no event shall TI's liability arising out of such information exceed the total purchase price of the TI part(s) at issue in this document sold by TI to Customer on an annual basis.

TAPE AND REEL INFORMATION

QUADRANT ASSIGNMENTS FOR PIN 1 ORIENTATION IN TAPE

*All dimensions are nominal

Device	Package Type	Package Drawing	Pins	SPQ	Reel Diameter (mm)	Reel Width W1 (mm)	A0 (mm)	B0 (mm)	K0 (mm)	P1 (mm)	W (mm)	Pin1 Quadrant
TPS2120YFPR	DSBGA	YFP	20	3000	180.0	8.4	1.66	2.06	0.56	4.0	8.0	Q1
TPS2120YFPR	DSBGA	YFP	20	3000	180.0	8.4	1.66	2.06	0.56	4.0	8.0	Q1
TPS2120YFPT	DSBGA	YFP	20	250	180.0	8.4	1.66	2.06	0.56	4.0	8.0	Q1
TPS2120YFPT	DSBGA	YFP	20	250	180.0	8.4	1.66	2.06	0.56	4.0	8.0	Q1
TPS2121RUXR	VQFN-HR	RUX	12	3000	180.0	8.4	2.25	2.8	1.1	4.0	8.0	Q1
TPS2121RUXT	VQFN-HR	RUX	12	250	180.0	8.4	2.25	2.8	1.1	4.0	8.0	Q1

TAPE AND REEL BOX DIMENSIONS

*All dimensions are nominal

Device	Package Type	Package Drawing	Pins	SPQ	Length (mm)	Width (mm)	Height (mm)
TPS2120YFPR	DSBGA	YFP	20	3000	182.0	182.0	20.0
TPS2120YFPR	DSBGA	YFP	20	3000	182.0	182.0	20.0
TPS2120YFPT	DSBGA	YFP	20	250	182.0	182.0	20.0
TPS2120YFPT	DSBGA	YFP	20	250	182.0	182.0	20.0
TPS2121RUXR	VQFN-HR	RUX	12	3000	182.0	182.0	20.0
TPS2121RUXT	VQFN-HR	RUX	12	250	182.0	182.0	20.0

IMPORTANT NOTICE AND DISCLAIMER

TI PROVIDES TECHNICAL AND RELIABILITY DATA (INCLUDING DATA SHEETS), DESIGN RESOURCES (INCLUDING REFERENCE DESIGNS), APPLICATION OR OTHER DESIGN ADVICE, WEB TOOLS, SAFETY INFORMATION, AND OTHER RESOURCES "AS IS" AND WITH ALL FAULTS, AND DISCLAIMS ALL WARRANTIES, EXPRESS AND IMPLIED, INCLUDING WITHOUT LIMITATION ANY IMPLIED WARRANTIES OF MERCHANTABILITY, FITNESS FOR A PARTICULAR PURPOSE OR NON-INFRINGEMENT OF THIRD PARTY INTELLECTUAL PROPERTY RIGHTS.

These resources are intended for skilled developers designing with TI products. You are solely responsible for (1) selecting the appropriate TI products for your application, (2) designing, validating and testing your application, and (3) ensuring your application meets applicable standards, and any other safety, security, regulatory or other requirements.

These resources are subject to change without notice. TI grants you permission to use these resources only for development of an application that uses the TI products described in the resource. Other reproduction and display of these resources is prohibited. No license is granted to any other TI intellectual property right or to any third party intellectual property right. TI disclaims responsibility for, and you will fully indemnify TI and its representatives against, any claims, damages, costs, losses, and liabilities arising out of your use of these resources.



TI's products are provided subject to [TI's Terms of Sale](#) or other applicable terms available either on [ti.com](https://www.ti.com) or provided in conjunction with such TI products. TI's provision of these resources does not expand or otherwise alter TI's applicable warranties or warranty disclaimers for TI products.

TI objects to and rejects any additional or different terms you may have proposed.

Mailing Address: Texas Instruments, Post Office Box 655303, Dallas, Texas 75265
Copyright © 2024, Texas Instruments Incorporated

Looking for pricing, stock, or lifecycle information?

Click below to explore more details on WIN SOURCE:

-  [View BK/PCB-2-1/2-R on WIN SOURCE](#)
-  [Eaton Bussmann Information](#)

Optimize Your Supply Chain with WIN SOURCE Solutions

-  Global Sourcing Solution
-  Obsolete Management
-  Cost Control Management
-  Shortage Management
-  Alternative Solution
-  Excess Inventory Management