



**THE DATASHEET OF
W29N01HVBINA**



W29N01HV



W29N01HV
1G-BIT 3.3V
NAND FLASH MEMORY



Table of Contents

1.	GENERAL DESCRIPTION	6
2.	FEATURES.....	6
3.	PACKAGE TYPES AND PIN CONFIGURATIONS	7
3.1	Pin assignment 48-pin TSOP1(x8).....	7
3.2	Pin assignment 48 ball VFBGA (x8).....	8
3.3	Pin assignment 63 ball VFBGA	9
3.4	Pin Descriptions.....	10
4.	PIN DESCRITPTIONS	11
4.1	Chip Enable (#CE).....	11
4.2	Write Enable (#WE).....	11
4.3	Read Enable (#RE)	11
4.4	Address Latch Enable (ALE)	11
4.5	Command Latch Enable (CLE)	11
4.6	Write Protect (#WP).....	11
4.7	Ready/Busy (RY/#BY)	11
4.8	Input and Output (I/Ox).....	11
5.	BLOCK DIAGRAM	12
6.	MEMORY ARRAY ORGANIZATION.....	13
6.1	Array Organization (x8)	13
7.	MODE SELECTION TABLE	14
8.	COMMAND TABLE.....	15
9.	DEVICE OPERATIONS	16
9.1	READ operation.....	16
9.1.1	PAGE READ (00h-30h).....	16
9.1.2	RANDOM DATA OUTPUT (05h-E0h).....	17
9.1.3	READ ID (90h)	17
9.1.4	READ PARAMETER PAGE (ECh)	18
9.1.5	READ STATUS (70h).....	21
9.2	PROGRAM operation	22
9.2.1	PAGE PROGRAM (80h-10h).....	22
9.2.2	SERIAL DATA INPUT (80h).....	22
9.2.3	RANDOM DATA INPUT (85h)	23
9.3	COPY BACK operation.....	24
9.3.1	READ for COPY BACK (00h-35h)	24
9.3.2	PROGRAM for COPY BACK (85h-10h).....	24
9.4	BLOCK ERASE operation	26
9.4.1	BLOCK ERASE (60h-D0h).....	26
9.5	RESET operation.....	27
9.5.1	RESET (FFh)	27
9.6	WRITE PROTECT	28
10.	ELECTRICAL CHARACTERISTICS.....	30
10.1	Absolute Maximum Ratings.....	30
10.2	Operating Ranges	30



10.3	Device power-up timing	31
10.4	DC Electrical Characteristics	32
10.5	AC Measurement Conditions	33
10.6	AC timing characteristics for Command, Address and Data Input	34
10.7	AC timing characteristics for Operation	35
10.8	Program and Erase Characteristics	36
11.	TIMING DIAGRAMS	37
12.	INVALID BLOCK MANAGEMENT	46
12.1	Invalid blocks	46
12.2	Initial invalid blocks	46
12.3	Error in operation	47
12.4	Addressing in program operation	48
13.	PACKAGE DIMENSIONS	49
13.1	TSOP 48-pin 12x20	49
13.2	Fine-Pitch Ball Grid Array 48-ball	50
13.3	Fine-Pitch Ball Grid Array 63-ball	51
14.	ORDERING INFORMATION	52
15.	VALID PART NUMBERS	53
16.	REVISION HISTORY	54



List of Tables

Table 3.1 Pin Descriptions	10
Table 6.1 Addressing	13
Table 7.1 Mode Selection	14
Table 8.1 Command Table.....	15
Table 9.1 Device ID and configuration codes for Address 00h.....	18
Table 9.2 ONFI identifying codes for Address 20h	18
Table 9.3 Parameter Page Output Value	20
Table 9.4 Status Register Bit Definition	21
Table 10.1 Absolute Maximum Ratings	30
Table 10.3 Operating Ranges	30
Table 10.5 DC Electrical Characteristics	32
Table 10.7 AC Measurement Conditions	33
Table 10.9 AC timing characteristics for Command, Address and Data Input	34
Table 10.11 AC timing characteristics for Operation	35
Table 10.13 Program and Erase Characteristics	36
Table 12.1 Valid Block Number	46
Table 12.2 Block failure.....	47
Table 15.1 Part Numbers for Industrial Temperature	53
Table 16.1 History Table	54



List of Figures

Figure 3-1 Pin Assignment 48-pin TSOP1 (Package code S)	7
Figure 3-2 Pin Assignment 48-ball VFBGA (Package code D).....	8
Figure 3-3 Pin Assignment 63-ball VFBGA (Package Code B)	9
Figure 5-1 NAND Flash Memory Block Diagram	12
Figure 6-1 Array Organization.....	13
Figure 9-1 Page Read Operations	16
Figure 9-2 Random Data Output.....	17
Figure 9-3 Read ID.....	17
Figure 9-4 Read Parameter Page	18
Figure 9-5 Read Status Operation	21
Figure 9-6 Page Program.....	22
Figure 9-7 Random Data Input	23
Figure 9-8 Copy Back Program Operation.....	25
Figure 10-1 Power ON/OFF sequence	31
Figure 11-1 Command Latch Cycle	37
Figure 11-2 Address Latch Cycle.....	37
Figure 11-3 Data Latch Cycle	38
Figure 11-4 Serial Access Cycle after Read	38
Figure 11-5 Serial Access Cycle after Read (EDO).....	39
Figure 11-6 Read Status Operation	39
Figure 11-7 Page Read Operation	40
Figure 11-8 #CE Don't Care Read Operation	40
Figure 11-9 Random Data Output Operation.....	41
Figure 11-10 Read ID.....	42
Figure 11-11 Page Program.....	42
Figure 11-12 #CE Don't Care Page Program Operation	43
Figure 11-13 Page Program with Random Data Input.....	43
Figure 11-14 Copy Back	44
Figure 11-15 Block Erase.....	44
Figure 11-16 Reset	45
Figure 12-12-1 Flow chart of create initial invalid block table	47
Figure 12-12-2 Bad block Replacement	48
Figure 13-1 TSOP 48-PIN 12X20mm	49
Figure 13-2 Fine-Pitch Ball Grid Array 48-Ball.....	50
Figure 13-3 Fine-Pitch Ball Grid Array 63-Ball (9x11mm)	51
Figure 14-1 Ordering Part Number Description	52



1. GENERAL DESCRIPTION

The W29N01HV (1G-bit) NAND Flash memory provides a storage solution for embedded systems with limited space, pins and power. It is ideal for code shadowing to RAM, solid state applications and storing media data such as, voice, video, text and photos. The device operates on a single 2.7V to 3.6V power supply with active current consumption as low as 25mA 10uA for CMOS standby current.

The memory array totals 138,412,032 bytes, and organized into 1,024 erasable blocks of 135,168 bytes. Each block consists of 64 programmable pages of 2,112-bytes each. Each page consists of 2,048-bytes for the main data storage area and 64-bytes for the spare data area (The spare area is typically used for error management functions).

The W29N01HV supports the standard NAND flash memory interface using the multiplexed 8-bit bus to transfer data, addresses, and command instructions. The five control signals, CLE, ALE, #CE, #RE and #WE handle the bus interface protocol. Also, the device has two other signal pins, the #WP (Write Protect) and the RY/#BY (Ready/Busy) for monitoring the device status.

2. FEATURES

• Basic Features

- Density : 1Gbit (Single chip solution)
- Vcc : 2.7V to 3.6V
- Bus width : x8
- Operating temperature
 - Industrial: -40°C to 85°C

• Single-Level Cell (SLC) technology.

• Organization

- Density: 1G-bit/128M-byte
- Page size
 - 2,112 bytes (2048 + 64 bytes)
- Block size
 - 64 pages (128K + 4K bytes)

• Highest Performance

- Read performance (Max.)
 - Random read: 25us
 - Sequential read cycle: 25ns
- Write Erase performance
 - Page program time: 250us(typ.)
 - Block erase time: 2ms(typ.)
- Endurance 100,000 Erase/Program Cycles⁽¹⁾
- 10-years data retention

• Command set

- Standard NAND command set
- Additional command support
 - Copy Back

• Lowest power consumption

- Read: 25mA(typ.3V),
- Program/Erase: 25mA(typ.3V),
- CMOS standby: 10uA(typ.)

• Space Efficient Packaging

- 48-pin standard TSOP1
- 48-ball VFBGA
- 63-ball VFBGA
- Contact Winbond for stacked packages/KGD

Note:

1. Endurance specification is based on 1bit/528 byte ECC (Error Correcting Code).



3. PACKAGE TYPES AND PIN CONFIGURATIONS

W29N01HV is offered in a 48-pin TSOP1 package (Code S) and 48-ball VFBGA package (Code D) and 63-ball VFBGA package (Code B) as shown in Figure 3-1 to 3-3, respectively. Package diagrams and dimensions are illustrated in Section: [Package Dimensions](#).

3.1 Pin assignment 48-pin TSOP1(x8)

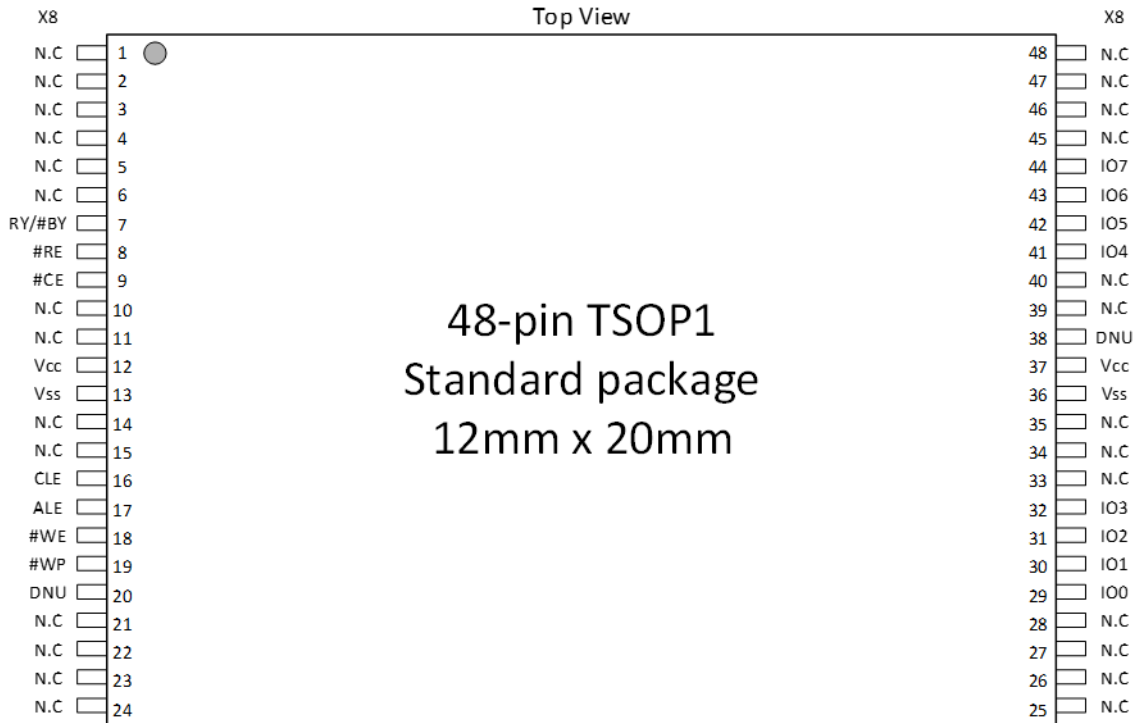

Figure 3-1 Pin Assignment 48-pin TSOP1 (Package code S)



3.2 Pin assignment 48 ball VFBGA (x8)

Top View, ball down

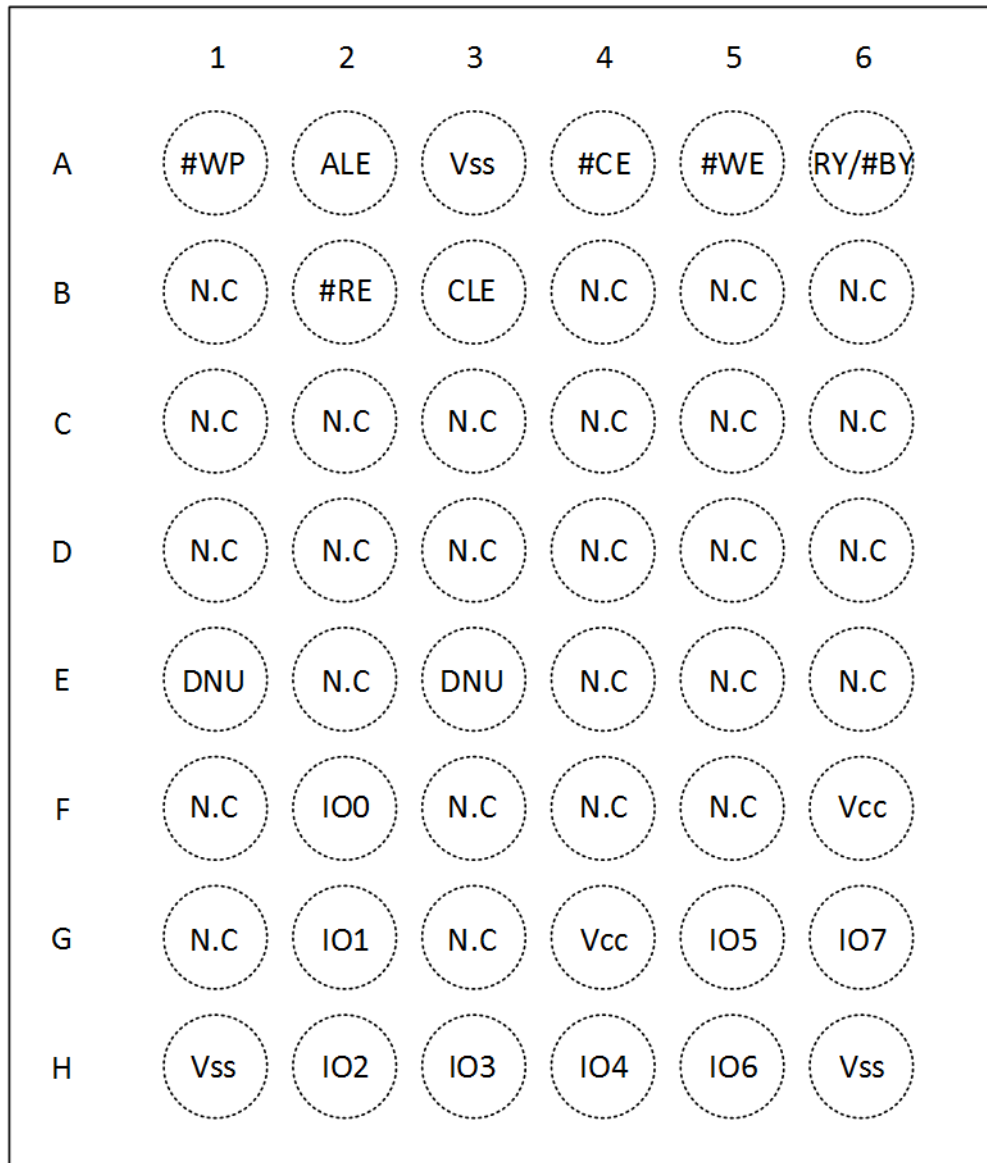

Figure 3-2 Pin Assignment 48-ball VFBGA (Package code D)



3.3 Pin assignment 63 ball VFBGA

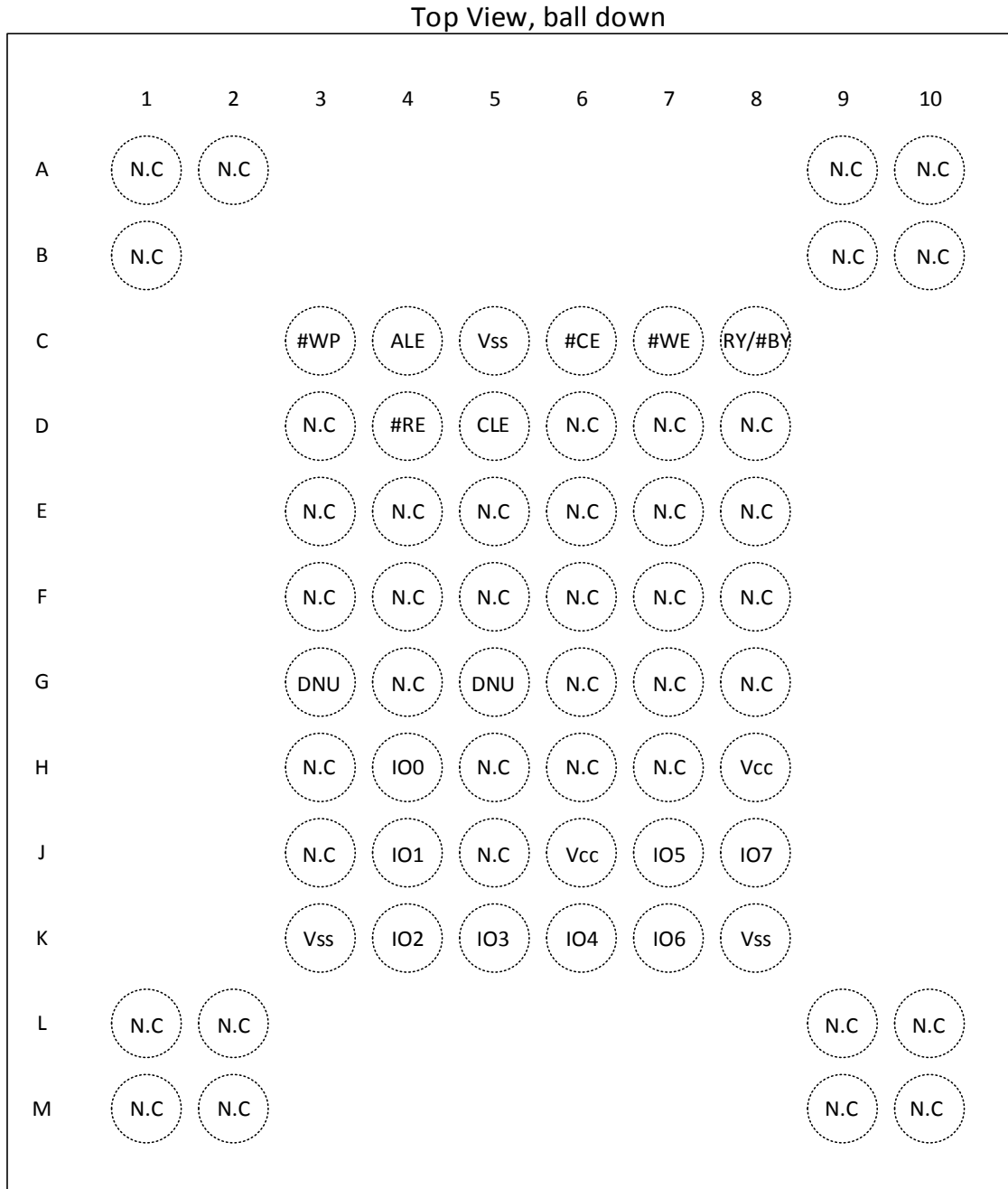

Figure 3-3 Pin Assignment 63-ball VFBGA (Package Code B)



3.4 Pin Descriptions

PIN NAME	I/O	FUNCTION
#WP	I	Write Protect
ALE	I	Address Latch Enable
#CE	I	Chip Enable
#WE	I	Write Enable
RY/#BY	O	Ready/Busy
#RE	I	Read Enable
CLE	I	Command Latch Enable
I/O[0-7]	I/O	Data Input/Output
Vcc	Supply	Power supply
Vss	Supply	Ground
DNU	-	Do Not Use: DNU's must be left unconnected.
N.C	-	No Connect

Table 3.1 Pin Descriptions

Note:

1. Connect all Vcc and Vss pins to power supply or ground. Do not leave Vcc or Vss disconnected.



4. PIN DESCRIPTIONS

4.1 Chip Enable (#CE)

#CE pin enables and disables device operation. When #CE is high the device is disabled and the I/O pins are set to high impedance and enters into standby mode if not busy. When #CE is set low the device will be enabled, power consumption will increase to active levels and the device is ready for Read and Write operations.

4.2 Write Enable (#WE)

#WE pin enables the device to control write operations to input pins of the device. Such as, command instructions, addresses and data that are latched on the rising edge of #WE.

4.3 Read Enable (#RE)

#RE pin controls serial data output from the pre-loaded Data Register. Valid data is present on the I/O bus after the tREA period from the falling edge of #RE. Column addresses are incremented for each #RE pulse.

4.4 Address Latch Enable (ALE)

ALE pin controls address input to the address register of the device. When ALE is active high, addresses are latched via the I/O pins on the rising edge of #WE.

4.5 Command Latch Enable (CLE)

CLE pin controls command input to the command register of the device. When CLE is active high, commands are latched into the command register via I/O pins on the rising edge of #WE.

4.6 Write Protect (#WP)

#WP pin can be used to prevent the inadvertent program/erase to the device. When #WP pin is active low, all program/erase operations are disabled.

4.7 Ready/Busy (RY/#BY)

RY/#BY pin indicates the device status. When RY/#BY output is low, it indicates that the device is processing either a program, erase or read operations. When it returns to high, those operations have completed. RY/#BY pin is an open drain.

4.8 Input and Output (I/Ox)

I/Ox bi-directional pins are used for the following; command, address and data operations.



5. BLOCK DIAGRAM

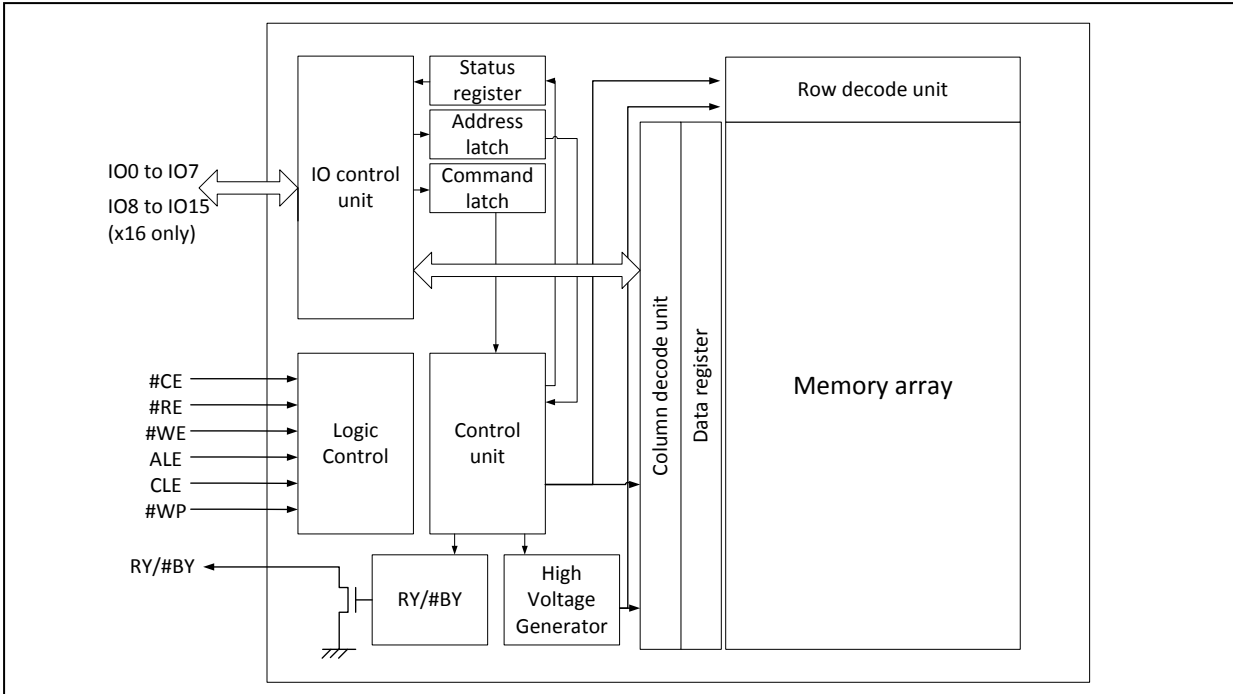

Figure 5-1 NAND Flash Memory Block Diagram



6. MEMORY ARRAY ORGANIZATION

6.1 Array Organization (x8)

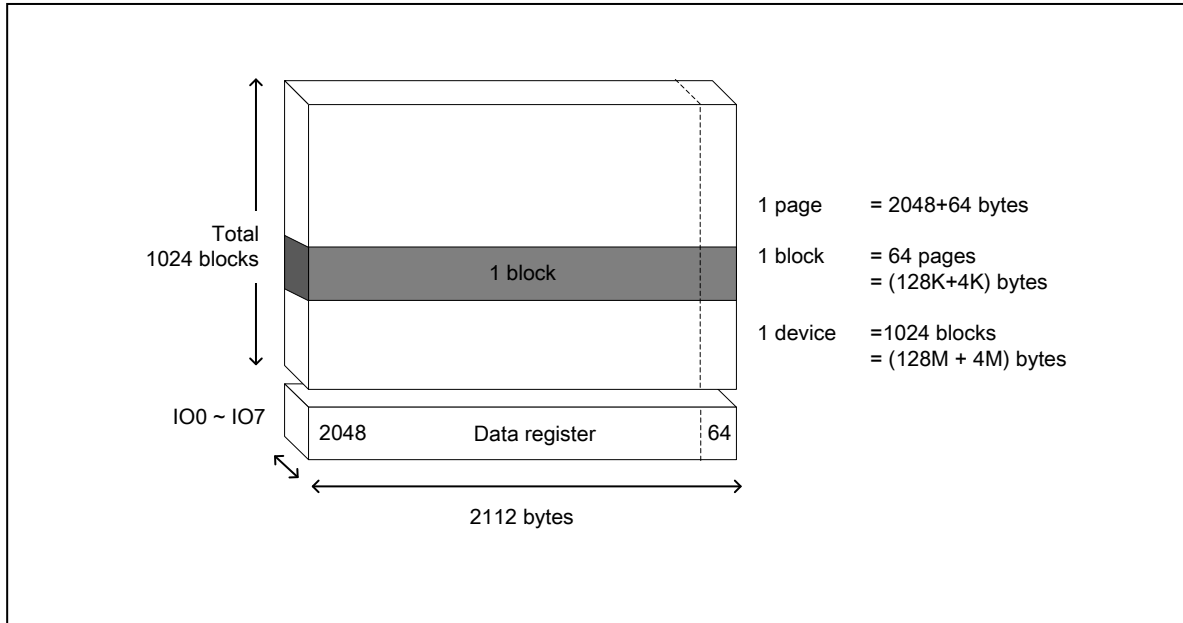

Figure 6-1 Array Organization

	I/O7	I/O6	I/O5	I/O4	I/O3	I/O2	I/O1	I/O0
1 st cycle	A7	A6	A5	A4	A3	A2	A1	A0
2 nd cycle	L	L	L	L	A11	A10	A9	A8
3 rd cycle	A19	A18	A17	A16	A15	A14	A13	A12
4 th cycle	A27	A26	A25	A24	A23	A22	A21	A20

Table 6.1 Addressing

Notes:

1. "L" indicates a low condition, which must be held during the address cycle to insure correct processing.
2. A0 to A11 during the 1st and 2nd cycles are column addresses. A12 to A27 during the 3rd and 4th cycles are row addresses.
3. The device ignores any additional address inputs that exceed the device's requirement.



7. MODE SELECTION TABLE

MODE		CLE	ALE	#CE	#WE	#RE	#WP
Read mode	Command input	H	L	L		H	X
	Address input	L	H	L		H	X
Program Erase mode	Command input	H	L	L		H	H
	Address input	L	H	L		H	H
Data input		L	L	L		H	H
Sequential Read and Data output		L	L	L	H		X
During read (busy)		X	X	X	X	H	X
During program (busy)		X	X	X	X	X	H
During erase (busy)		X	X	X	X	X	H
Write protect		X	X	X	X	X	L
Standby		X	X	H	X	X	0V/Vcc

Table 7.1 Mode Selection

Notes:

1. "H" indicates a HIGH input level, "L" indicates a LOW input level, and "X" indicates a Don't Care Level.
2. #WP should be biased to CMOS HIGH or LOW for standby.



8. COMMAND TABLE

COMMAND	1 ST CYCLE	2 ND CYCLE	3 rd CYCLE	4 th CYCLE	Acceptable during busy
PAGE READ	00h	30h			
READ for COPY BACK	00h	35h			
READ ID	90h				
READ STATUS	70h				Yes
RESET	FFh				Yes
PAGE PROGRAM	80h	10h			
PROGRAM for COPY BACK	85h	10h			
BLOCK ERASE	60h	D0h			
RANDOM DATA INPUT*1	85h				
RANDOM DATA OUTPUT*1	05h	E0h			
READ PARAMETER PAGE	ECh				

Table 8.1 Command Table

Notes:

1. RANDOM DATA INPUT and RANDOM DATA OUTPUT command is only to be used within a page.
2. Any command that are not in the above table are considered as undefined and are prohibited as inputs.



9. DEVICE OPERATIONS

9.1 READ operation

9.1.1 PAGE READ (00h-30h)

When the device powers on, 00h command is latched to command register. Therefore, system only issues four address cycles and 30h command for initial read from the device. This operation can also be entered by writing 00h command to the command register, and then write four address cycles, followed by writing 30h command. After writing 30h command, the data is transferred from NAND array to Data Register during t_R . Data transfer progress can be done by monitoring the status of the RY/#BY signal output. RY/#BY signal will be LOW during data transfer. Also, there is an alternate method by using the READ STATUS (70h) command. If the READ STATUS command is issued during read operation, the Read (00h) command must be re-issued to read out the data from Data Register. When the data transfer is complete, RY/#BY signal goes HIGH, and the data can be read from Data Register by toggling #RE. Read is sequential from initial column address to the end of the page. (See Figure 9-1)

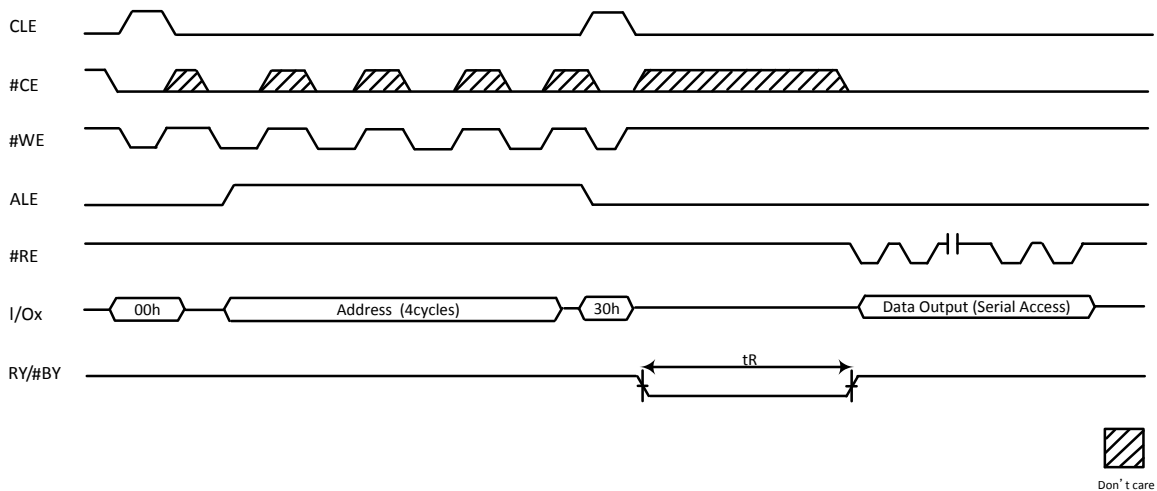

Figure 9-1 Page Read Operations



9.1.2 RANDOM DATA OUTPUT (05h-E0h)

The RANDOM DATA OUTPUT allows the selection of random column addresses to read out data from a single or multiple of addresses. The use of the RANDOM DATA OUTPUT command is available after the PAGE READ (00h-30h) sequence by writing the 05h command following by the two cycle column address and then the E0h command. Toggling #RE will output data sequentially. The RANDOM DATA OUTPUT command can be issued multiple times, but limited to the current loaded page.

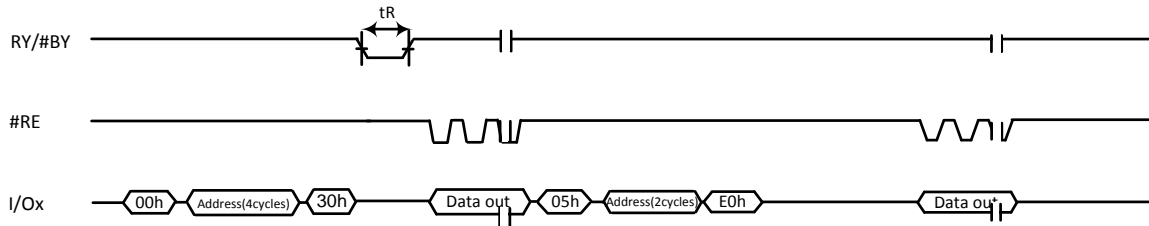

Figure 9-2 Random Data Output

9.1.3 READ ID (90h)

READ ID command is comprised of two modes determined by the input address, device (00h) or ONFI (20h) identification information. To enter the READ ID mode, write 90h to the Command Register followed by a 00h address cycle, then toggle #RE for 5 single byte cycles, W29N01HV. The pre-programmed code includes the Manufacturer ID, Device ID, and Product-Specific Information (see Table 9.1). If the READ ID command is followed by 20h address, the output code includes 4 single byte cycles of ONFI identifying information (See Table 9.2). The device remains in the READ ID Mode until the next valid command is issued.

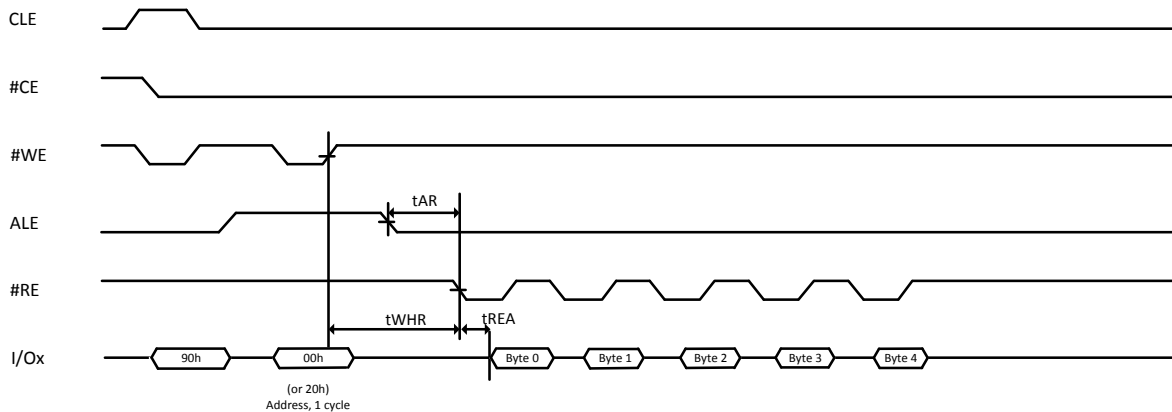

Figure 9-3 Read ID



# of Byte/Cycles	1 st Byte/Cycle	2 nd Byte/Cycle	3 rd Byte/Cycle	4 th Byte/Cycle	5 th Byte/Cycle
W29N01HV	EFh	F1h	00h	95h	00h
Description	MFR ID	Device ID	Cache Programming Non-supported	Page Size:2KB Spare Area Size:64B BLK Size w/o Spare:128KB Organized:x8 or x16 Serial Access:25ns	

Table 9.1 Device ID and configuration codes for Address 00h

# of Byte/Cycles	1 st Byte/Cycle	2 nd Byte/Cycle	3 rd Byte/Cycle	4 th Byte/Cycle
Code	4Fh	4Eh	46h	49h

Table 9.2 ONFI identifying codes for Address 20h

9.1.4 READ PARAMETER PAGE (ECh)

READ PARAMETER PAGE can read out the device’s parameter data structure, such as, manufacturer information, device organization, timing parameters, key features, and other pertinent device parameters. The data structure is stored with at least three copies in the device’s parameter page. Figure 9-4 shows the READ PARAMETER PAGE timing. The RANDOM DATA OUTPUT (05h-E0h) command is supported during data output.

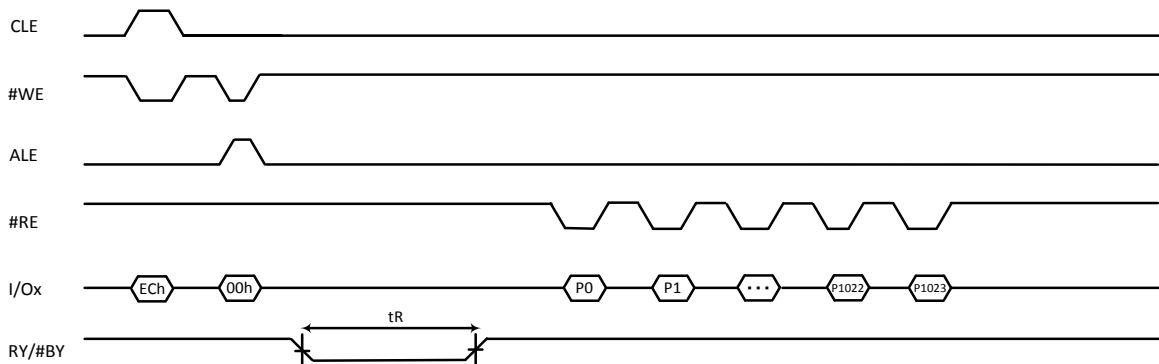

Figure 9-4 Read Parameter Page



9.1.5 READ STATUS (70h)

The W29N01HV has an 8-bit Status Register which can be read during device operation. Refer to Table 9.4 for specific Status Register definitions. After writing 70h command to the Command Register, read cycles will only read from the Status Register. The status can be read from I/O[7:0] outputs, as long as #CE and #RE are LOW. Note; #RE does not need to be toggled for Status Register read. The Command Register remains in status read mode until another command is issued. To change to normal read mode, issue the PAGE READ (00h) command. After the PAGE READ command is issued, data output starts from the initial column address.

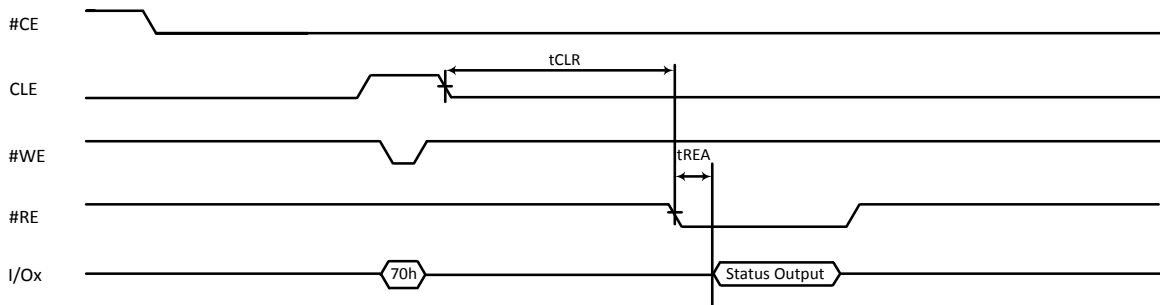

Figure 9-5 Read Status Operation

SR bit	Page Read	Page Program	Block Erase	Definition
I/O 0	Not Use	Pass/Fail	Pass/Fail	0=Successful Program/Erase 1=Error in Program/Erase
I/O 1	Not Use	Not Use	Not Use	0=Successful Program 1=Error in Program
I/O 2	Not Use	Not Use	Not Use	0
I/O 3	Not Use	Not Use	Not Use	0
I/O 4	Not Use	Not Use	Not Use	0
I/O 5	Ready/Busy	Ready/Busy	Ready/Busy	Ready = 1 Busy = 0
I/O 6	Ready/Busy	Ready/Busy	Ready/Busy	Ready = 1 Busy = 0
I/O 7	Write Protect	Write Protect	Write Protect	Unprotected = 1 Protected = 0

Table 9.4 Status Register Bit Definition



9.2 PROGRAM operation

9.2.1 PAGE PROGRAM (80h-10h)

The W29N01HV Page Program command will program pages sequentially within a block, from the lower order page address to higher order page address. Programming pages out of sequence is prohibited. The W29N01HV supports partial-page programming operations up to 4 times before an erase is required if partitioning a page. Note; programming a single bit more than once without first erasing it is not supported.

9.2.2 SERIAL DATA INPUT (80h)

Page Program operation starts with the execution of the Serial Data Input command (80h) to the Command Register, following next by inputting four address cycles and then the data is loaded. Serial data is loaded to Data register with each #WE cycle. The Program command (10h) is written to the Command Register after the serial data input is finished. At this time the internal write state controller automatically executes the algorithms for program and verifies operations. Once the programming starts, determining the completion of the program process can be done by monitoring the RY/#BY output or the Status Register Bit 6, which will follow the RY/#BY signal. RY/#BY will stay LOW during the internal array programming operation during the period of (tPROG). During page program operation, only two commands are available, READ STATUS (70h) and RESET (FFh). When the device status goes to the ready state, Status Register Bit 0 (I/O0) indicates whether the program operation passed (Bit0=0) or failed (Bit0=1), (see Figure 9-6). The Command Register remains in read status mode until the next command is issued.

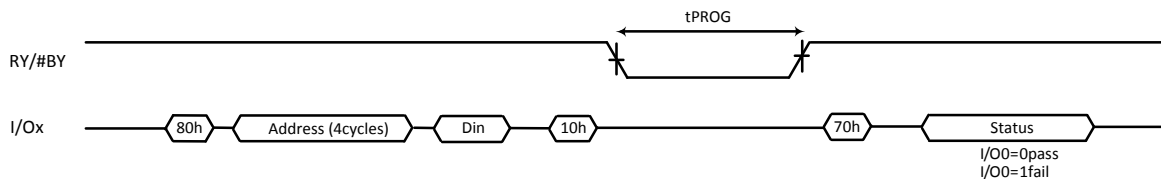

Figure 9-6 Page Program



9.2.3 RANDOM DATA INPUT (85h)

After the Page Program (80h) execution of the initial data has been loaded into the Data register, if the need for additional writing of data is required, using the RANDOM DATA INPUT (85h) command can perform this function to a new column address prior to the Program (10h) command. The RANDOM DATA INPUT command can be issued multiple times in the same page (See Figure 9-7).

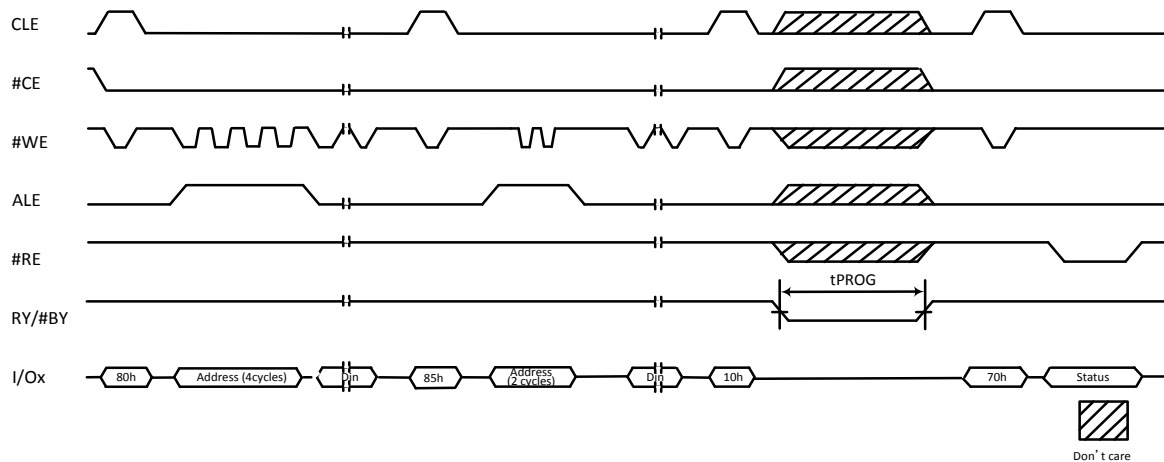

Figure 9-7 Random Data Input



9.3 COPY BACK operation

Copy Back operations require two command sets. Issue a READ for COPY BACK (00h-35h) command first, then the PROGRAM for COPY BACK (85h-10h) command.

9.3.1 READ for COPY BACK (00h-35h)

The READ for COPY BACK command is used together with the PROGRAM for COPY BACK (85h-10h) command. To start execution, READ for COPY BACK (00h) command is written to the Command Register, followed by the four cycles of the source page address. To start the transfer of the selected page data from the memory array to the Data register, write the 35h command to the Command Register.

After execution of the READ for COPY BACK command sequence and RY/#BY returns to HIGH marking the completion of the operation, the transferred data from the source page into the Data register may be read out by toggling #RE. Data is output sequentially from the column address that was originally specified with the READ for COPY BACK command. RANDOM DATA OUTPUT (05h-E0h) commands can be issued multiple times without any limitation after READ for COPY BACK command has been executed (see Figures 9-8 and 9-9).

At this point the device is in ready state to accept the PROGRAM for COPY BACK command.

9.3.2 PROGRAM for COPY BACK (85h-10h)

After the READ for COPY BACK command operation has been completed and RY/#BY goes HIGH, the PROGRAM for COPY BACK command can be written to the Command Register. The command results in the transfer of data to the Data Register, then internal operations start programming of the new destination page. The sequence would be, write 85h to the Command Register, followed by the four cycle destination page address to the NAND array. Next write the 10h command to the Command Register; this will signal the internal controller to automatically start to program the data to new destination page. During this programming time, RY/#BY will LOW. The READ STATUS command can be used instead of the RY/#BY signal to determine when the program is complete. When Status Register Bit 6 (I/O6) equals to "1", Status Register Bit 0 (I/O0) will indicate if the operation was successful or not.

The RANDOM DATA INPUT (85h) command can be used during the PROGRAM for COPY BACK command for modifying the original data. Once the data is copied into the Data register using the READ for COPY BACK (00h-35h) command, follow by writing the RANDOM DATA INPUT (85h) command, along with the address of the data to be changed. The data to be changed is placed on the external data pins. This operation copies the data into the Data register. Once the 10h command is written to the Command Register, the original data and the modified data are transferred to the Data Register, and programming of the new page commences. The RANDOM DATA INPUT command can be issued numerous times without limitation, as necessary before starting the programming sequence with 10h command.

Since COPY BACK operations do not use external memory and the data of source page might include a bit errors, a competent ECC scheme should be developed to check the data before programming data to a new destination page.

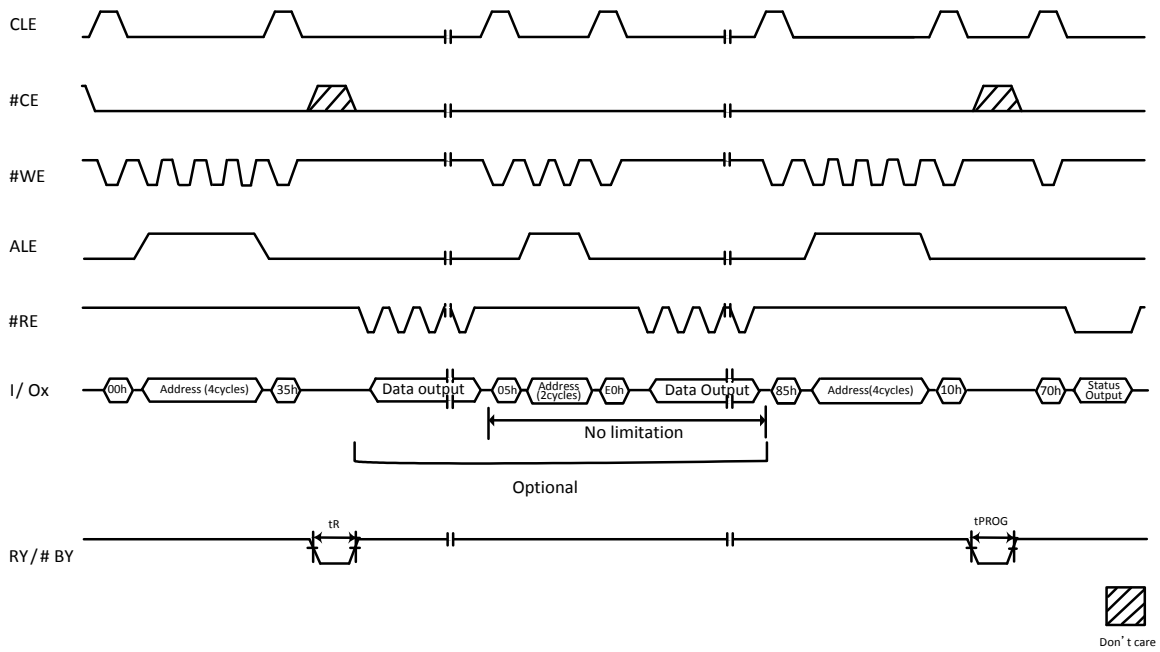

Figure 9-8 Copy Back Program Operation

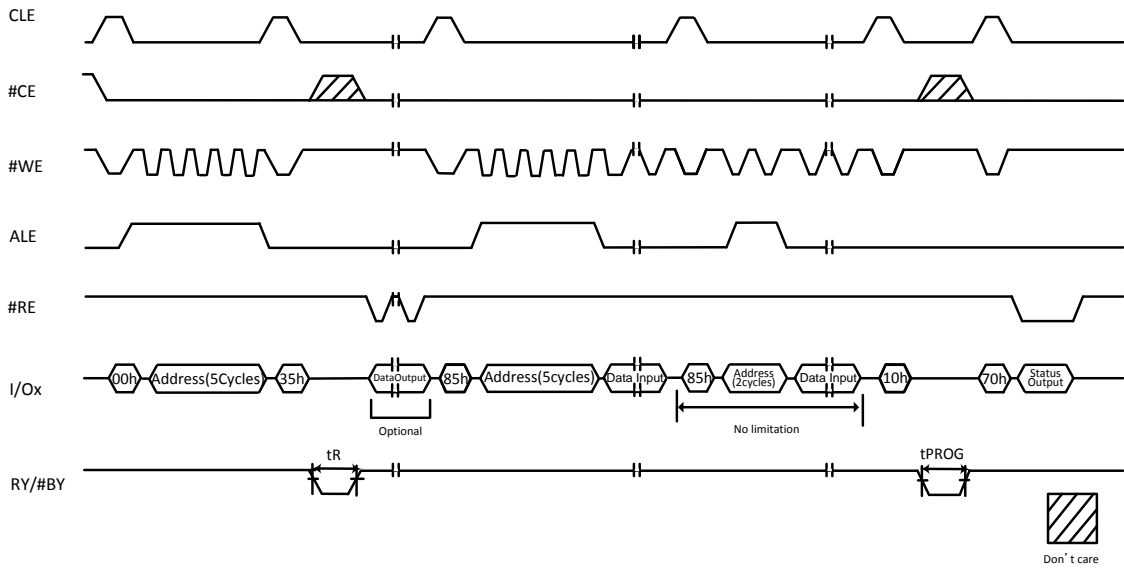

Figure 9-9 Copy Back Operation with Random Data Input



9.4 BLOCK ERASE operation

9.4.1 BLOCK ERASE (60h-D0h)

Erase operations happen at the architectural block unit. This W29N01HV has 1024 erase blocks. Each block is organized into 64 pages (2112 bytes/page), 132K bytes (128K + 4K bytes)/block. The BLOCK ERASE command operates on a block by block basis.

Erase Setup command (60h) is written to the Command Register. Next, the two cycle block address is written to the device. The page address bits are loaded during row address cycle, but are ignored. The Erase Confirm command (D0h) is written to the Command Register at the rising edge of #WE, RY/#BY goes LOW and the internal controller automatically handles the block erase sequence of operation. RY/#BY goes LOW during Block Erase internal operations for a period of tBERS,

The READ STATUS (70h) command can be used for confirm block erase status. When Status Register Bit6 (I/O6) becomes to "1", block erase operation is finished. Status Register Bit0 (I/O0) will indicate a pass/fail condition (see Figure 9-10).

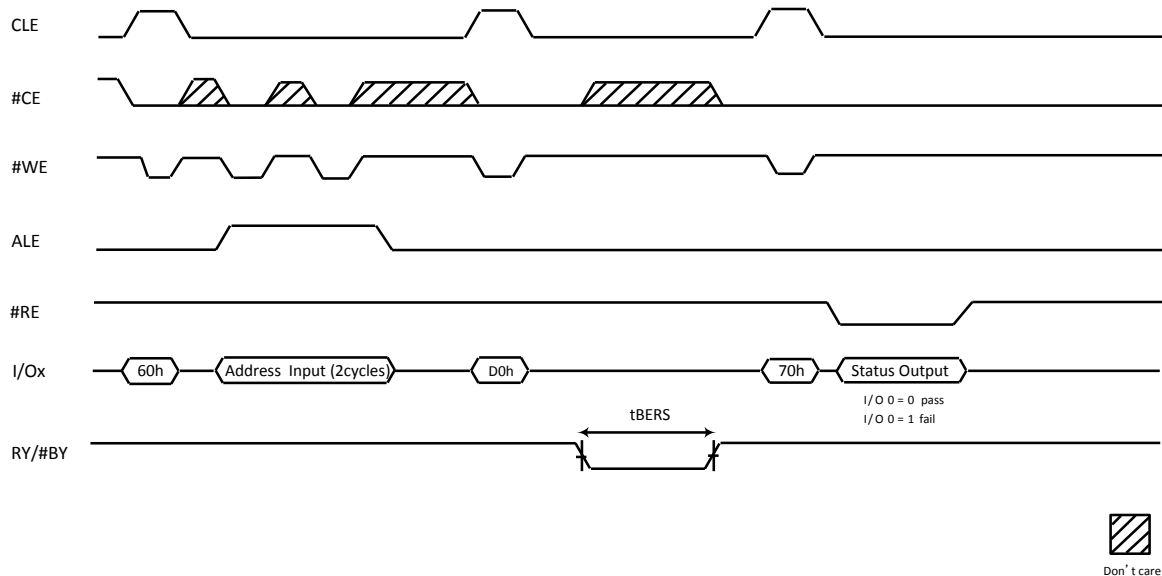

Figure 9-10 Block Erase Operation



9.5 RESET operation

9.5.1 RESET (FFh)

READ, PROGRAM, and ERASE commands can be aborted by the RESET (FFh) command during the time the W29N01HV is in the busy state. The Reset operation puts the device into known status. The data that is processed in either the programming or erasing operations are no longer valid. This means the data can be partially programmed or erased and therefore data is invalid. The Command Register is cleared and is ready to accept next command. The Data Register contents are marked invalid.

The Status Register indicates a value of E0h when #WP is HIGH; otherwise a value of 60h is written when #WP is LOW. After RESET command is written to the command register, RY/#BY goes LOW for a period of t_{RST} (see Figure 9-11).

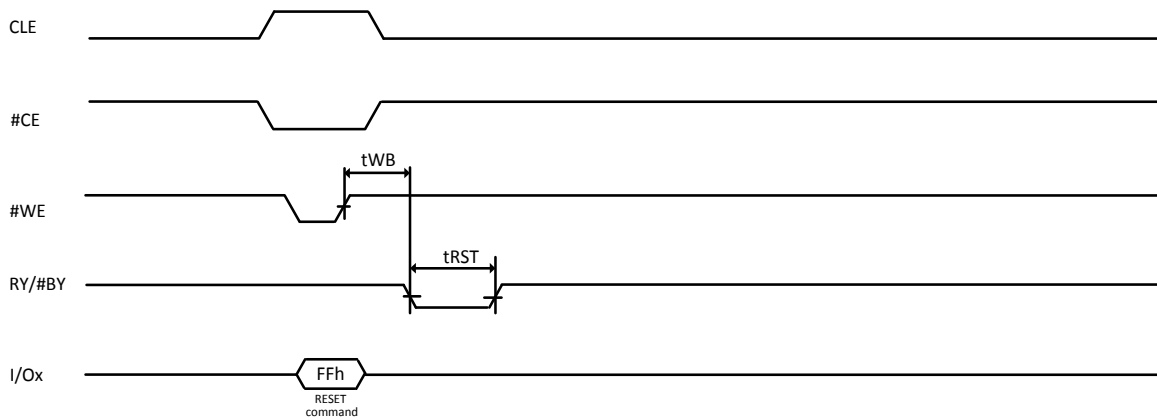

Figure 9-11 Reset Operation



9.6 WRITE PROTECT

#WP pin can enable or disable program and erase commands preventing or allowing program and erase operations. Figure 9-12 to 9-17 shows the enabling or disabling timing with #WP setup time (t_{WW}) that is from rising or falling edge of #WP to latch the first commands. After first command is latched, #WP pin must not toggle until the command operation is complete and the device is in the ready state. (Status Register Bit5 (I/O5) equal 1)

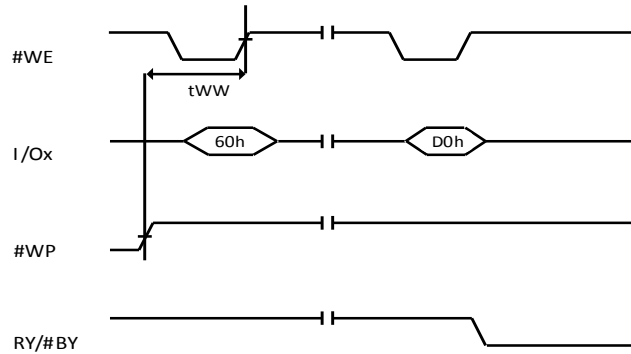

Figure 9-12 Erase Enable

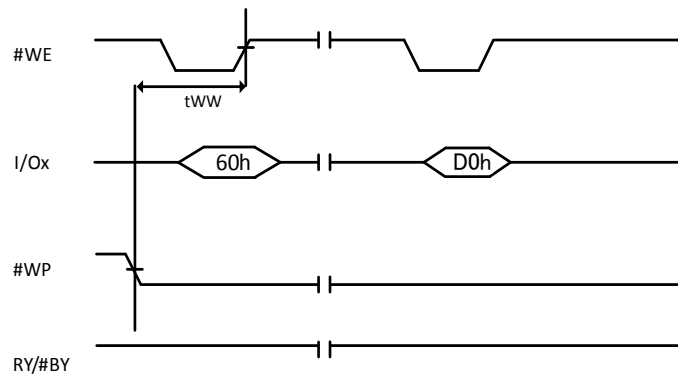

Figure 9-13 Erase Disable

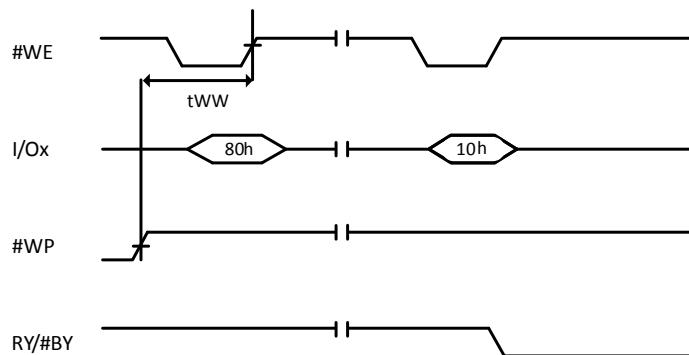

Figure 9-14 Program Enable

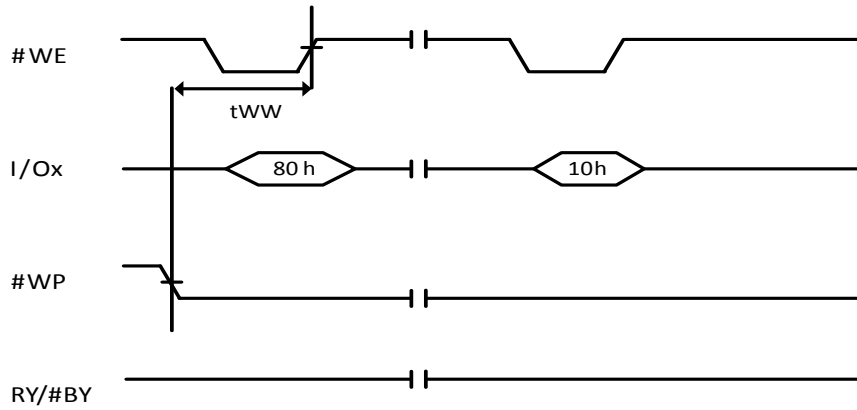

Figure 9-15 Program Disable

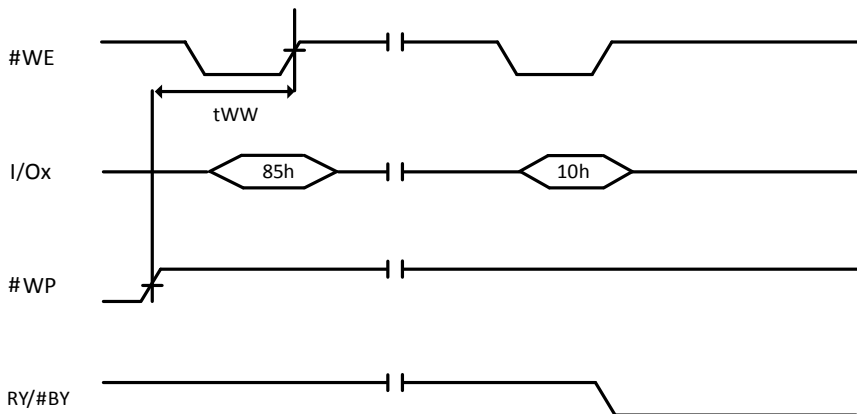

Figure 9-16 Program for Copy Back Enable

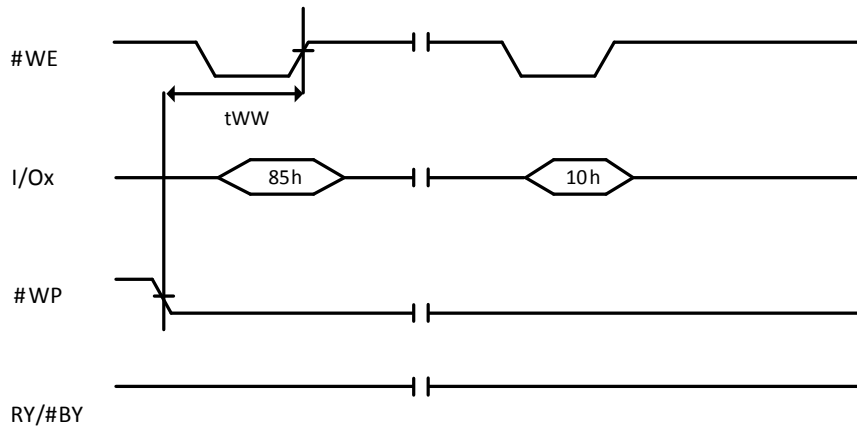

Figure 9-17 Program for Copy Back Disable



10. ELECTRICAL CHARACTERISTICS

10.1 Absolute Maximum Ratings

PARAMETERS	SYMBOL	CONDITIONS	RANGE	UNIT
Supply Voltage	VCC		-0.6 to +4.6	V
Voltage Applied to Any Pin	VIN	Relative to Ground	-0.6 to +4.6	V
Storage Temperature	TSTG		-65 to +150	°C
Short circuit output current, I/Os			5	mA

Table 10.1 Absolute Maximum Ratings

Notes:

1. Minimum DC voltage is -0.6V on input/output pins. During transitions, this level may undershoot to -2.0V for periods <30ns.
2. Maximum DC voltage on input/output pins is Vcc+0.3V which, during transitions, may overshoot to Vcc+2.0V for periods <20ns
3. This device has been designed and tested for the specified operation ranges. Proper operation outside of these levels is not guaranteed. Exposure to absolute maximum ratings may affect device reliability. Exposure beyond absolute maximum ratings may cause permanent damage.

10.2 Operating Ranges

PARAMETER	SYMBOL	CONDITIONS	SPEC		UNIT
			MIN	MAX	
Supply Voltage	VCC		2.7	3.6	V
Ambient Temperature, Operating	TA	Industrial	-40	+85	°C

Table 10.2 Operating Ranges



10.3 Device power-up timing

The device is designed to avoid unexpected program/erase operations during power transitions. When the device is powered on, an internal voltage detector disables all functions whenever Vcc is below about 2V at 3V device. Write Protect (#WP) pin provides hardware protection and is recommended to be kept at VIL during power up and power down. A recovery time of minimum 1ms is required before internal circuit gets ready for any command sequences (See Figure 10-1).

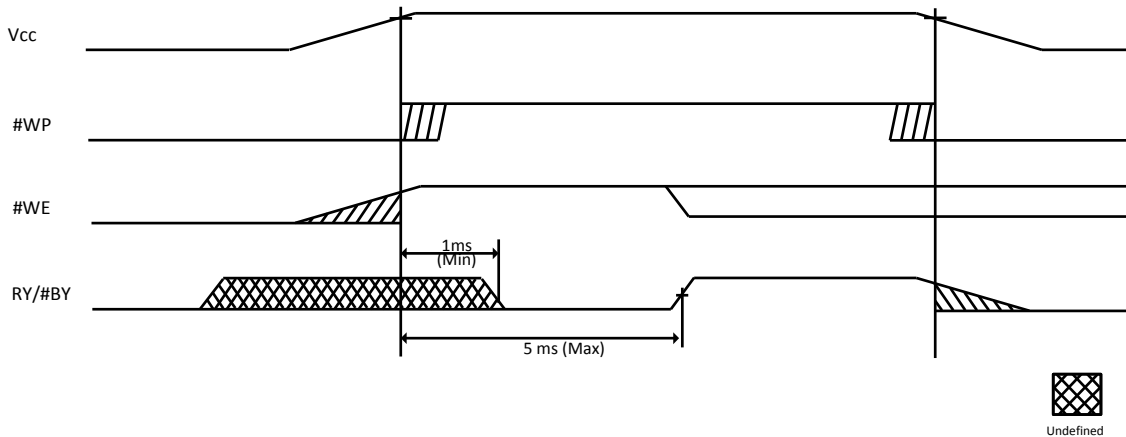

Figure 10-1 Power ON/OFF sequence



10.4 DC Electrical Characteristics

PARAMETER	SYMBOL	CONDITIONS	SPEC			UNIT
			MIN	TYP	MAX	
Sequential Read current	Icc1	tRC= tRC MIN #CE=VIL IOUT=0mA	-	25	35	mA
Program current	Icc2	-	-	25	35	mA
Erase current	Icc3	-	-	25	35	mA
Standby current (TTL)	ISB1	#CE=VIH #WP=0V/Vcc	-	-	1	mA
Standby current (CMOS)	ISB2	#CE=Vcc - 0.2V #WP=0V/Vcc	-	10	50	μA
Input leakage current	ILI	VIN= 0 V to Vcc	-	-	± 10	μA
Output leakage current	ILO	VOUT=0V to Vcc	-	-	± 10	μA
Input high voltage	VIH	I/O7~0, #CE,#WE,#RE, #WP,CLE,ALE	0.8 x Vcc	-	Vcc + 0.3	V
Input low voltage	VIL	-	-0.3	-	0.2 x Vcc	V
Output high voltage ⁽¹⁾	VOH	IOH=-400μA	2.4	-	-	V
Output low voltage ⁽¹⁾	VOL	IOL=2.1mA	-	-	0.4	V
Output low current ⁽²⁾	IOL(RY/#BY)	VOL=0.4V	8	10		mA

Table 10.3 DC Electrical Characteristics

Note:

1. VOH and VOL may need to be relaxed if I/O drive strength is not set to full.
2. IOL (RY/#BY) may need to be relaxed if RY/#BY pull-down strength is not set to full



10.5 AC Measurement Conditions

PARAMETER	SYMBOL	SPEC		UNIT
		MIN	MAX	
Input Capacitance ^{(1), (2)}	CIN	-	10	pF
Input/Output Capacitance ^{(1), (2)}	CIO	-	10	pF
Input Rise and Fall Times	TR/TF	5		ns
Input Pulse Voltages	-	0 to VCC		V
Input/Output timing Voltage	-	Vcc/2		V
Output load ⁽¹⁾	CL	1TTL GATE and CL=30pF		-

Table 10.4 AC Measurement Conditions

Notes:

1. Verified on device characterization , not 100% tested
2. Test conditions TA=25°C, f=1MHz, VIN=0V



10.6 AC timing characteristics for Command, Address and Data Input

PARAMETER	SYMBOL	SPEC		UNIT
		MIN	MAX	
ALE to Data Loading Time ⁽¹⁾	tADL	70	-	ns
ALE Hold Time	tALH	5	-	ns
ALE setup Time	tALS	10	-	ns
#CE Hold Time	tCH	5	-	ns
CLE Hold Time	tCLH	5	-	ns
CLE setup Time	tCLS	10	-	ns
#CE setup Time	tCS	15	-	ns
Data Hold Time	tDH	5	-	ns
Data setup Time	tDS	10	-	ns
Write Cycle Time	tWC	25	-	ns
#WE High Hold Time	tWH	10	-	ns
#WE Pulse Width	tWP	12	-	ns
#WP setup Time	tWW	100	-	ns

Table 10.5 AC timing characteristics for Command, Address and Data Input

Note:

1. tADL is the time from the #WE rising edge of final address cycle to the #WE rising edge of first data cycle.



10.7 AC timing characteristics for Operation

PARAMETER	SYMBOL	SPEC		UNIT
		MIN	MAX	
ALE to #RE Delay	tAR	10	-	ns
#CE Access Time	tCEA	-	25	ns
#CE HIGH to Output High-Z ⁽¹⁾	tCHZ	-	30	ns
CLE to #RE Delay	tCLR	10	-	ns
#CE HIGH to Output Hold	tCOH	15	-	ns
Output High-Z to #RE LOW	tIR	0	-	ns
Data Transfer from Cell to Data Register	tR	-	25	μs
READ Cycle Time	tRC	25	-	ns
#RE Access Time	tREA	-	20	ns
#RE HIGH Hold Time	tREH	10	-	ns
#RE HIGH to Output Hold	tRHOH	15	-	ns
#RE HIGH to #WE LOW	tRHW	100	-	ns
#RE HIGH to Output High-Z ⁽¹⁾	tRHZ	-	100	ns
#RE LOW to output hold	tRLOH	5	-	ns
#RE Pulse Width	tRP	12	-	ns
Ready to #RE LOW	tRR	20	-	ns
Reset Time (READ/PROGRAM/ERASE) ⁽²⁾	tRST	-	5/10/500	μs
#WE HIGH to Busy ⁽³⁾	tWB	-	100	ns
#WE HIGH to #RE LOW	tWHR	60	-	ns

Table 10.6 AC timing characteristics for Operation

Notes:

1. Transition is measured $\pm 200\text{mV}$ from steady-state voltage with load. This parameter is sampled and not 100 % tested.
2. The RESET (FFh) command is issued while the device is idle, the device goes busy for a maximum of 5us.
3. Do not issue new command during tWB, even if RY/#BY is ready.



10.8 Program and Erase Characteristics

PARAMETER	SYMBOL	SPEC		UNIT
		TYP	MAX	
Number of partial page programs	NoP	-	4	cycles
Page Program time	tPROG	250	700	μ s
Block Erase Time	tBERS	2	10	ms

Table 10.7 Program and Erase Characteristics



11. TIMING DIAGRAMS

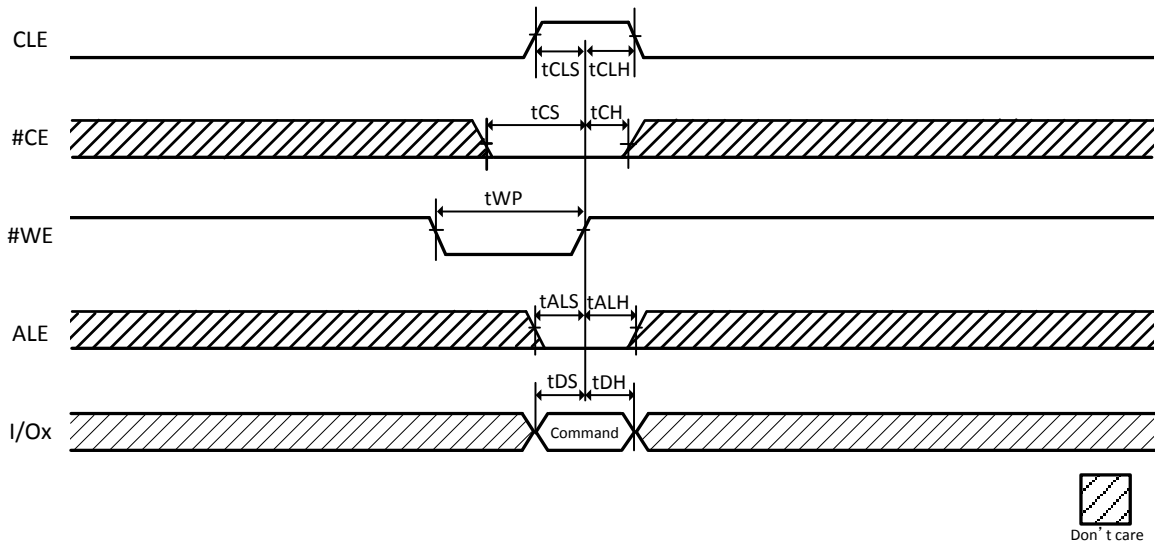

Figure 11-1 Command Latch Cycle

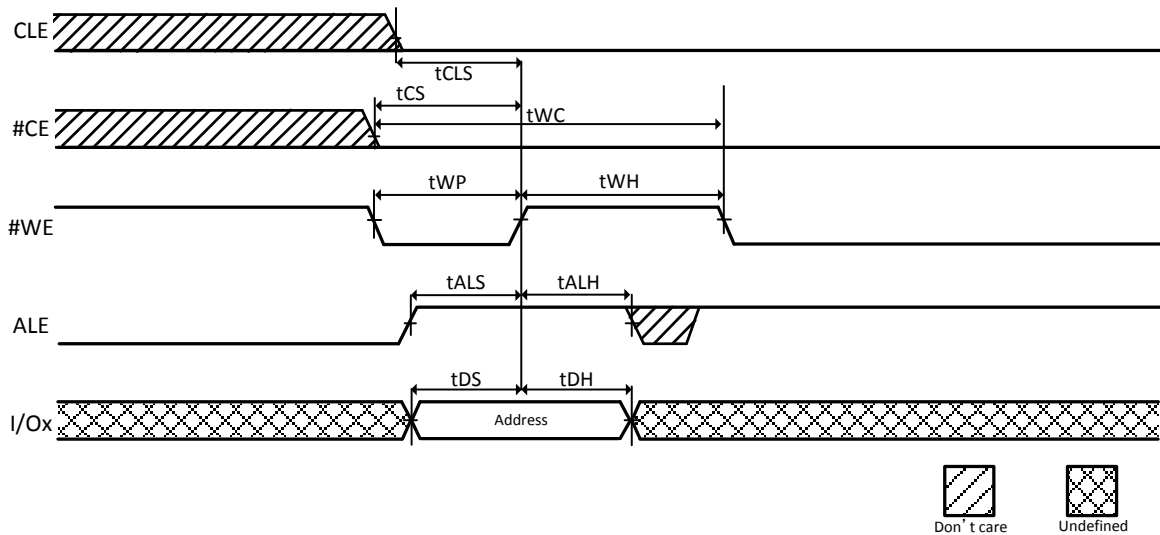
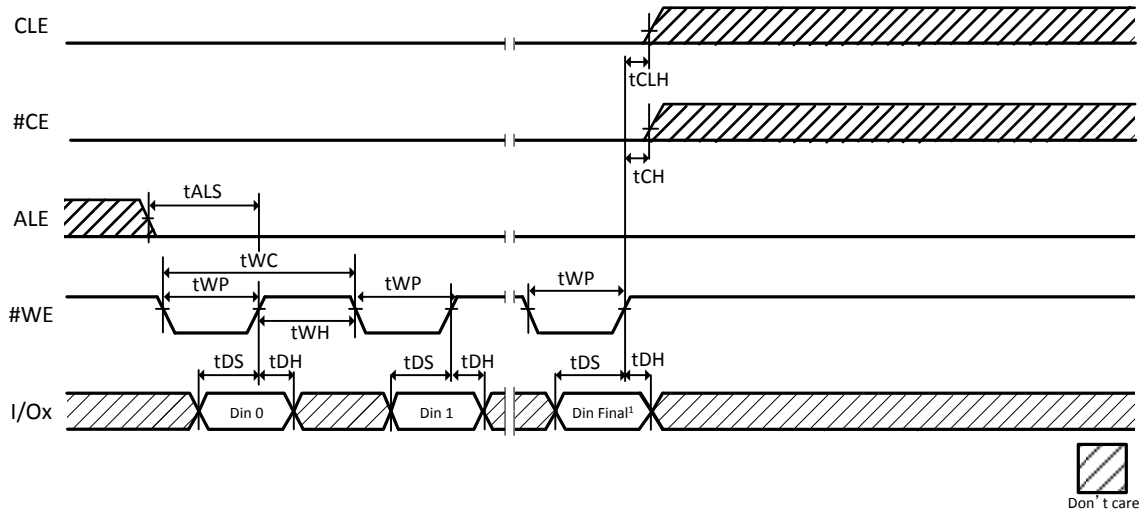

Figure 11-2 Address Latch Cycle



Note: 1. Din Final = 2,111(x8)

Figure 11-3 Data Latch Cycle

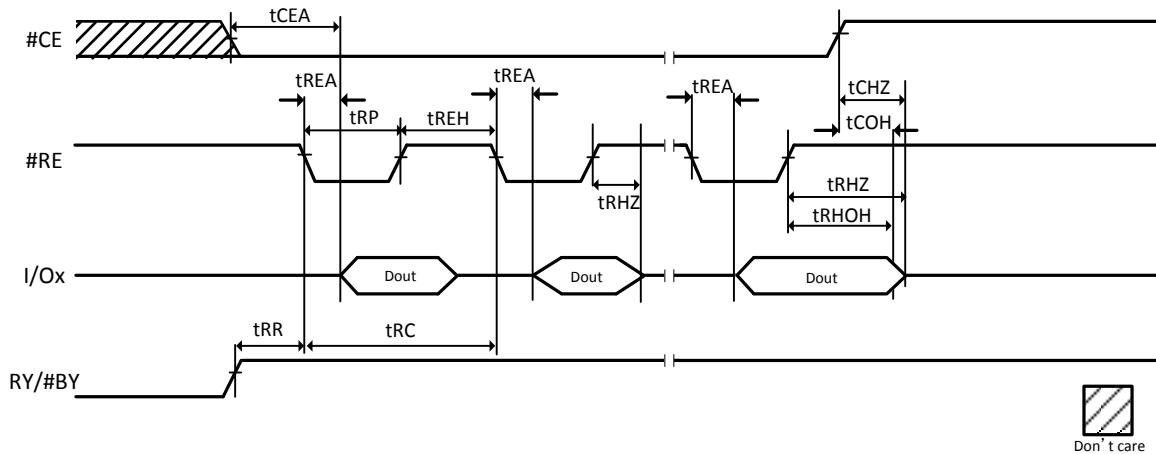

Figure 11-4 Serial Access Cycle after Read

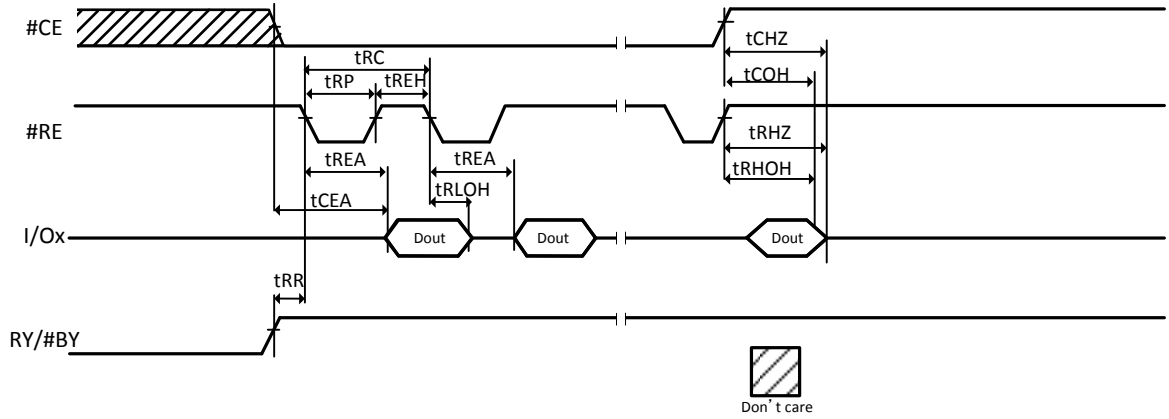

Figure 11-5 Serial Access Cycle after Read (EDO)

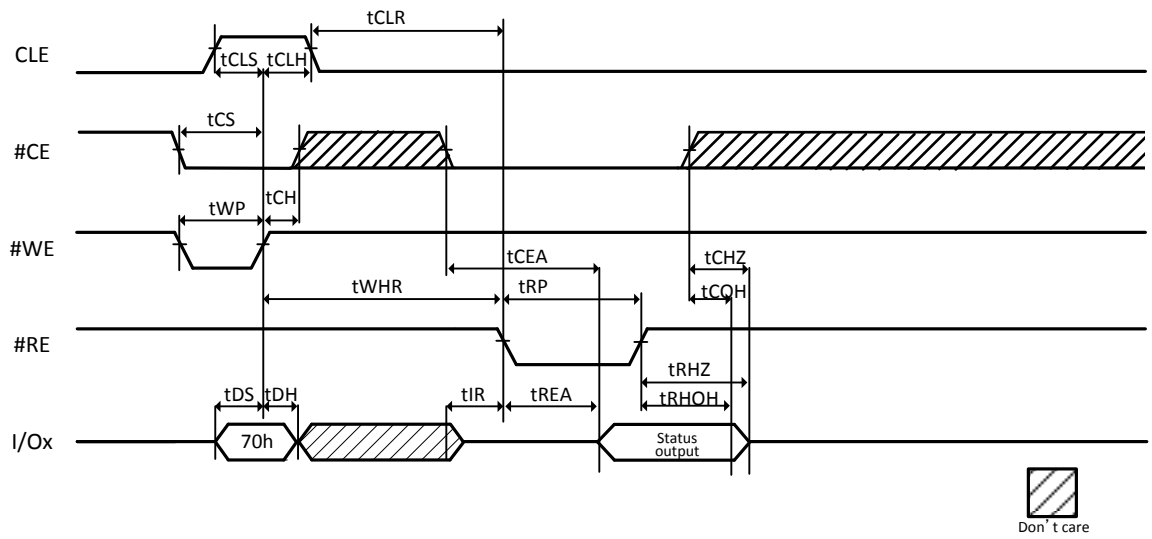

Figure 11-6 Read Status Operation

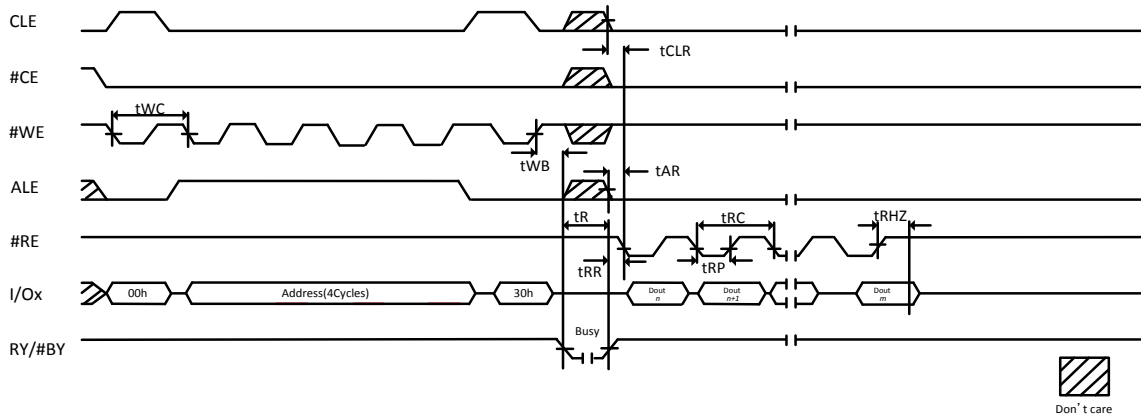

Figure 11-7 Page Read Operation

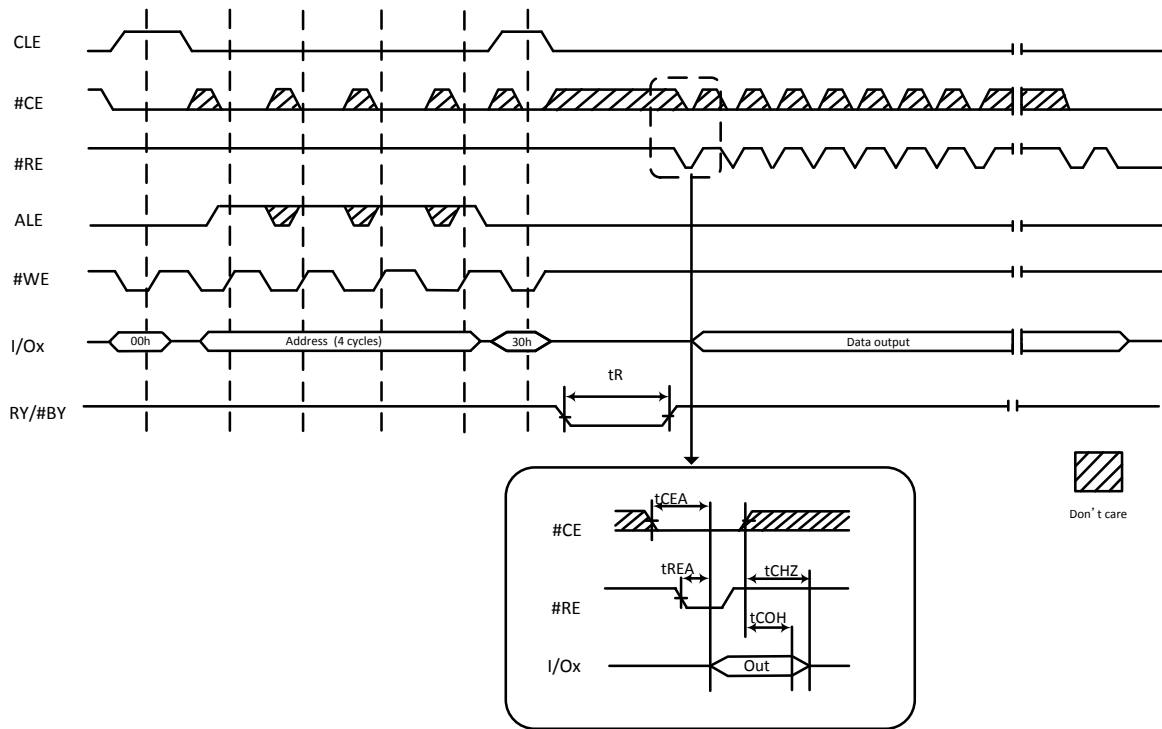

Figure 11-8 #CE Don't Care Read Operation

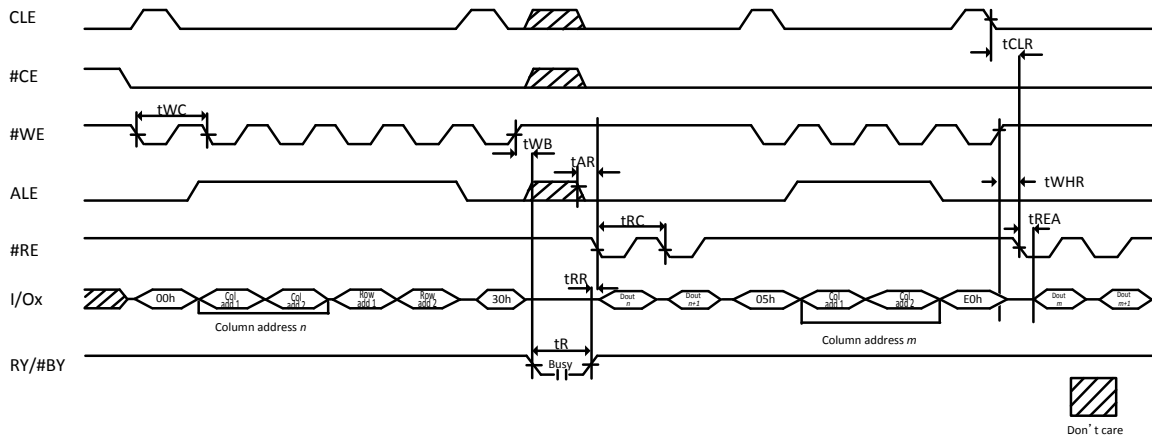
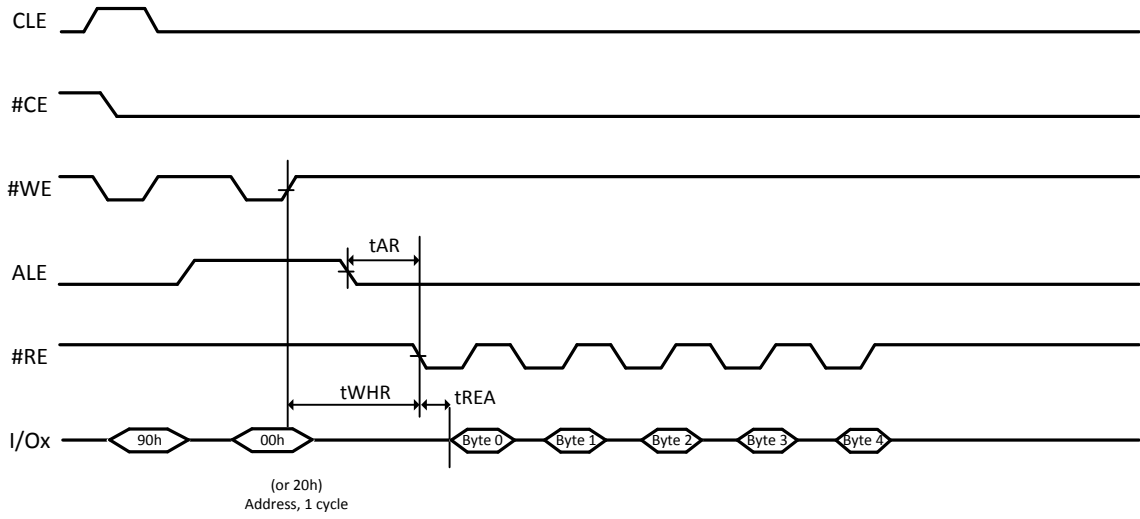

Figure 11-9 Random Data Output Operation



Note: 1. See Table 9.1 for actual value.

Figure 11-10 Read ID

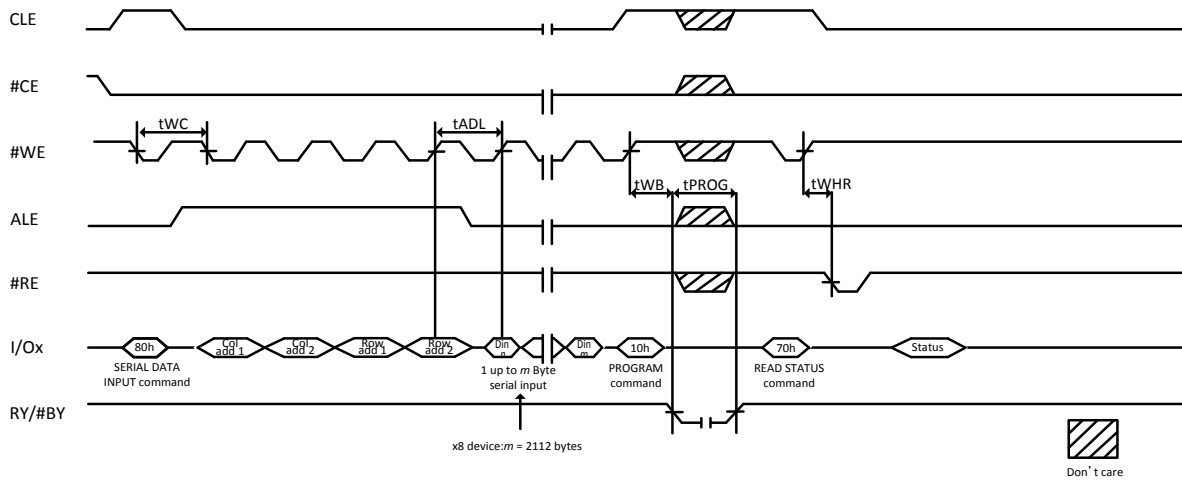

Figure 11-11 Page Program

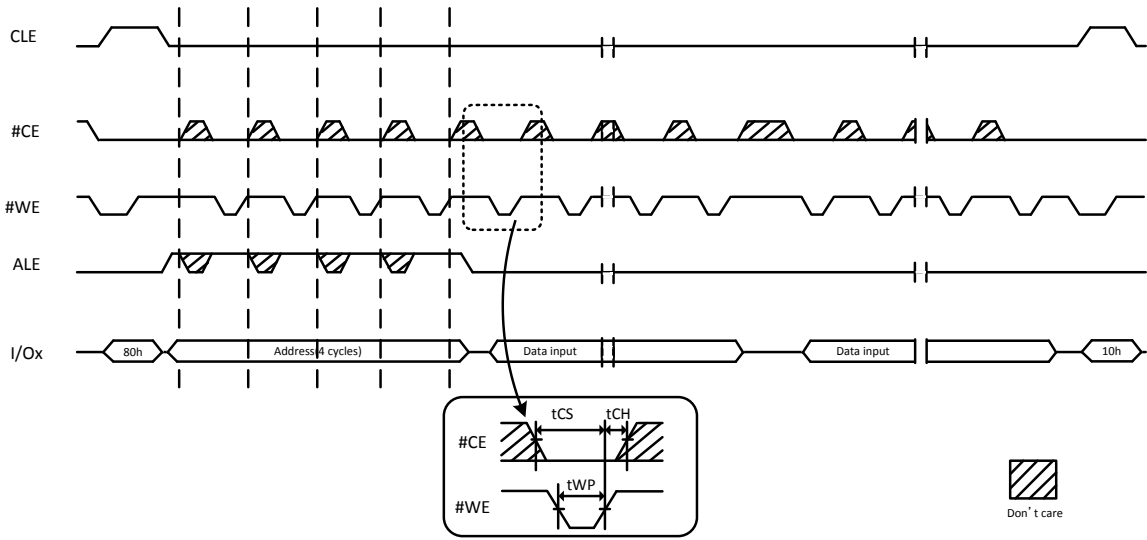

Figure 11-12 #CE Don't Care Page Program Operation

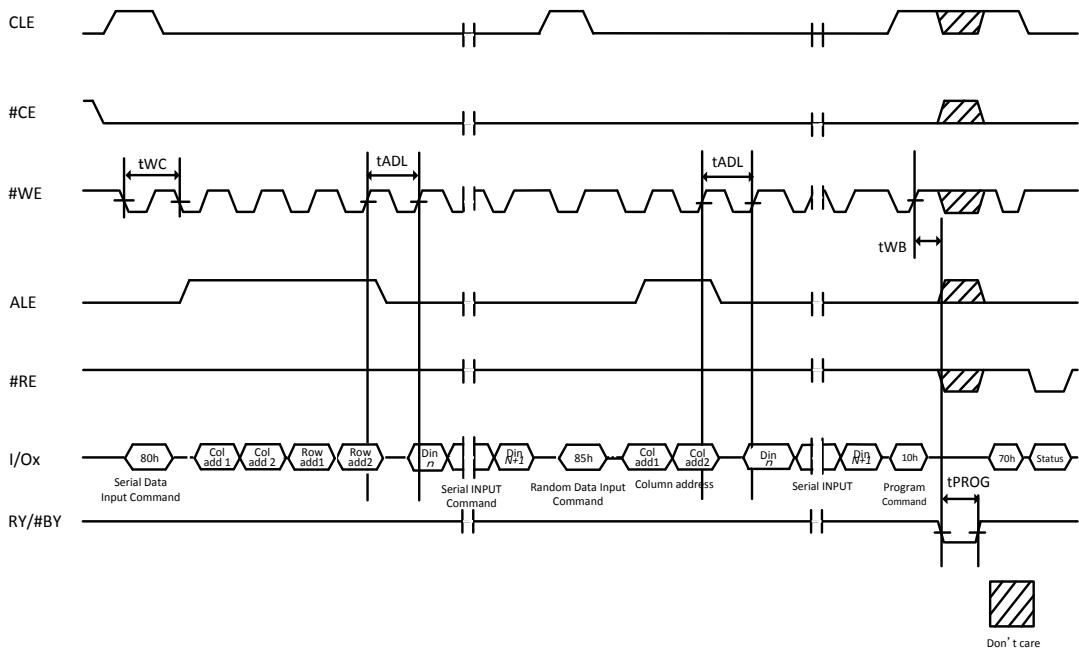

Figure 11-13 Page Program with Random Data Input

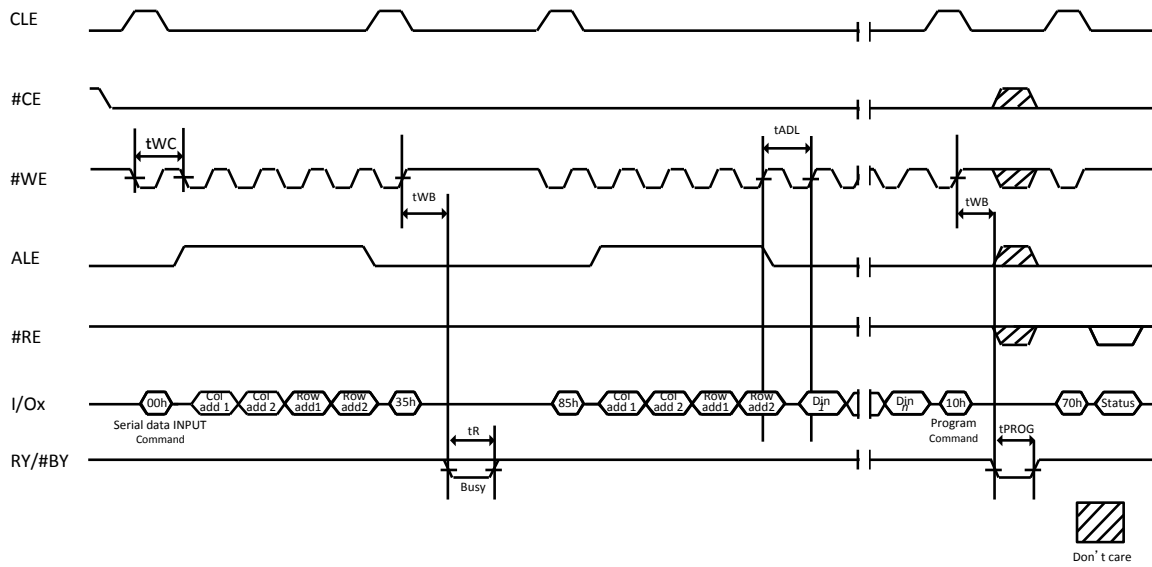

Figure 11-14 Copy Back

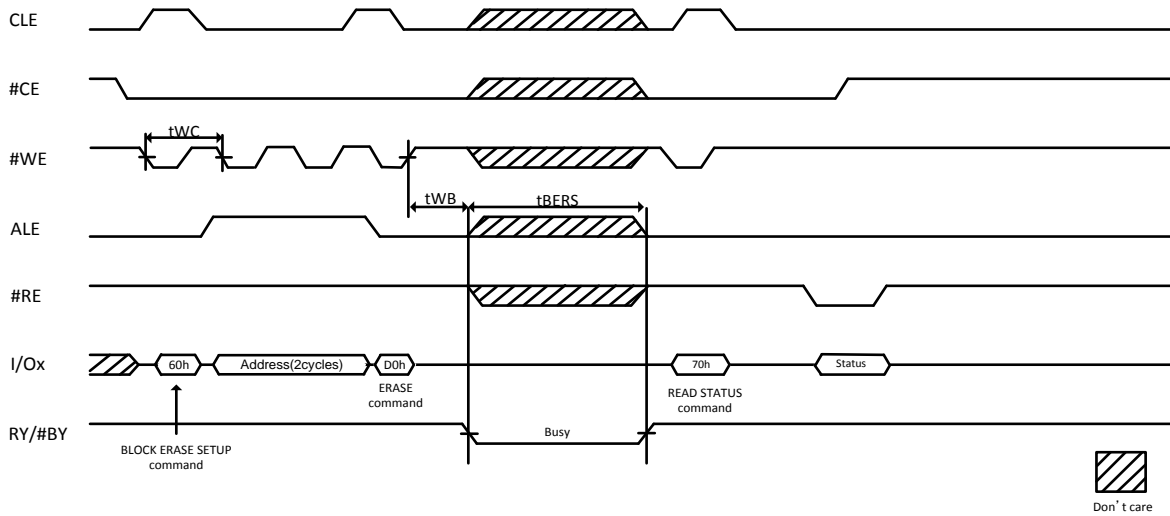

Figure 11-15 Block Erase

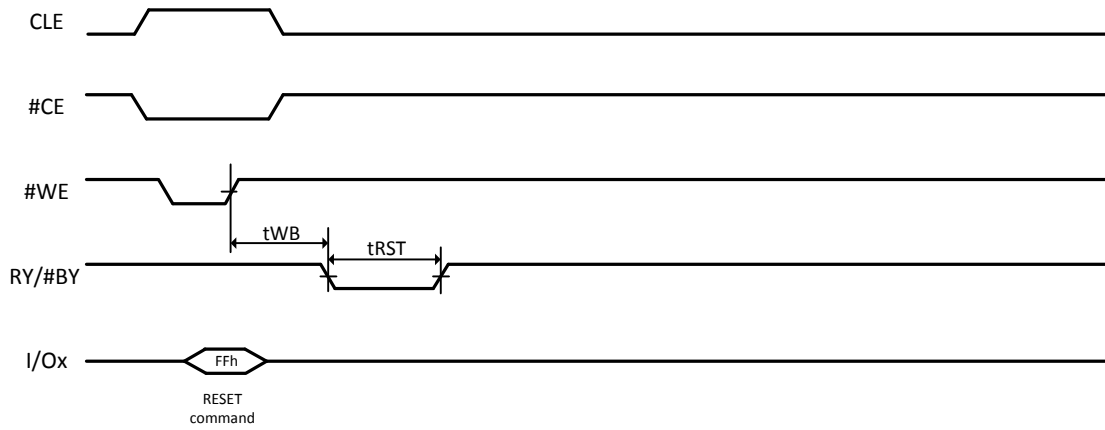

Figure 11-16 Reset



12. INVALID BLOCK MANAGEMENT

12.1 Invalid blocks

The W29N01HV may have initial invalid blocks when it ships from factory. Also, additional invalid blocks may develop during the use of the device. Nvb represents the minimum number of valid blocks in the total number of available blocks (See Table 12.1). An invalid block is defined as blocks that contain one or more bad bits. Block 0, block address 00h is guaranteed to be a valid block at the time of shipment.

Parameter	Symbol	Min	Max	Unit
Valid block number	Nvb	1004	1024	blocks

Table 12.1 Valid Block Number

12.2 Initial invalid blocks

Initial invalid blocks are defined as blocks that contain one or more invalid bits when shipped from factory.

Although the device contains initial invalid blocks, a valid block of the device is of the same quality and reliability as all valid blocks in the device with reference to AC and DC specifications. The W29N01HV has internal circuits to isolate each block from other blocks and therefore, the invalid blocks will not affect the performance of the entire device.

Before the device is shipped from the factory, it will be erased and invalid blocks are marked. All initial invalid blocks are marked with non-FFh at the first byte of spare area on the 1st or 2nd page. The initial invalid block information cannot be recovered if inadvertently erased. Therefore, software should be created to initially check for invalid blocks by reading the marked locations before performing any program or erase operation, and create a table of initial invalid blocks as following flow chart

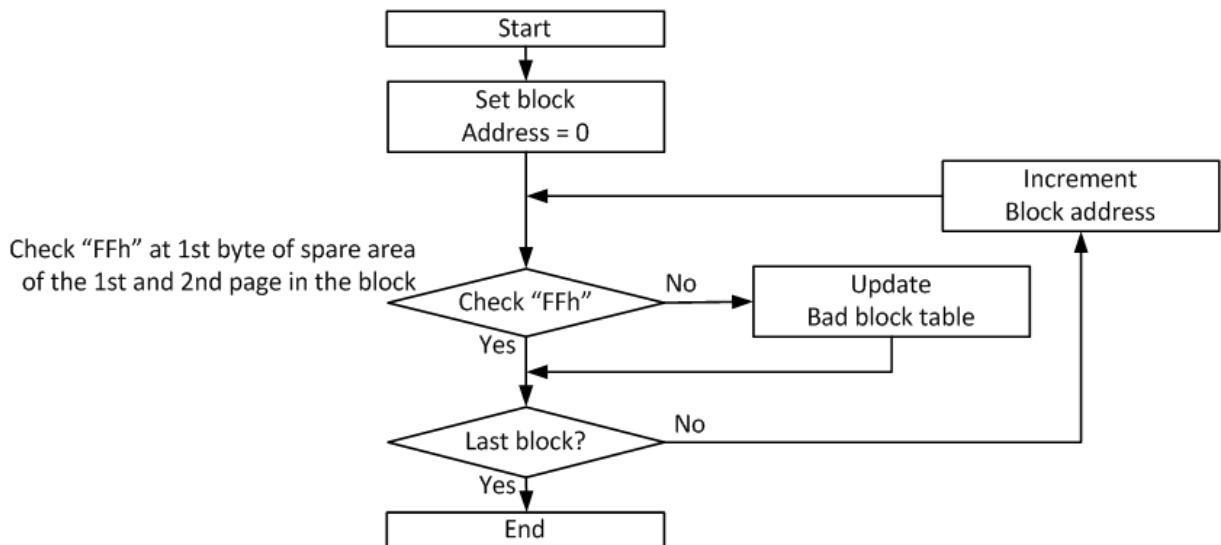

Figure 12-12-1 Flow chart of create initial invalid block table

12.3 Error in operation

Additional invalid blocks may develop in the device during its life cycle. Following the procedures herein is required to guarantee reliable data in the device.

After each program and erase operation, check the status read to determine if the operation failed. In case of failure, a block replacement should be done with a bad-block management algorithm. The system has to use a minimum 1bit ECC per 528 bytes of data to ensure data recovery.

Operation	Detection and recommended procedure
Erase	Status read after erase → Block Replacement
Program	Status read after program → Block Replacement
Read	Verify ECC → ECC correction

Table 12.2 Block failure

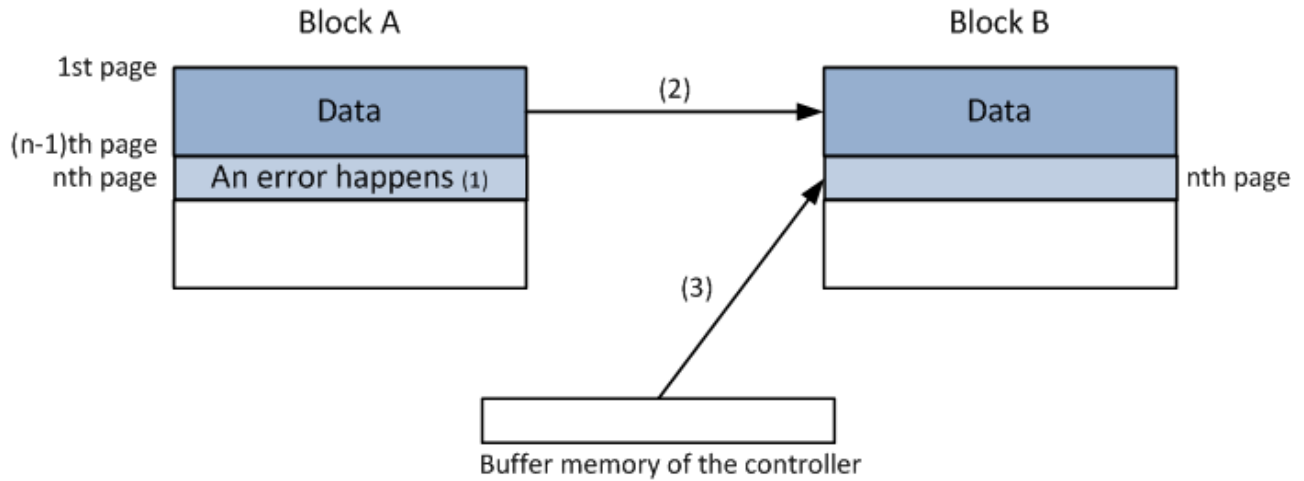

Figure 12-12-2 Bad block Replacement

Note:

1. An error happens in the nth page of block A during program or erase operation.
2. Copy the data in block A to the same location of block B which is valid block.
3. Copy the nth page data of block A in the buffer memory to the nth page of block B
4. Creating or updating bad block table for preventing further program or erase to block A

12.4 Addressing in program operation

The pages within the block have to be programmed sequentially from LSB (least significant bit) page to the MSB (most significant bit) within the block. The LSB is defined as the start page to program, does not need to be page 0 in the block. Random page programming is prohibited.



13. PACKAGE DIMENSIONS

13.1 TSOP 48-pin 12x20

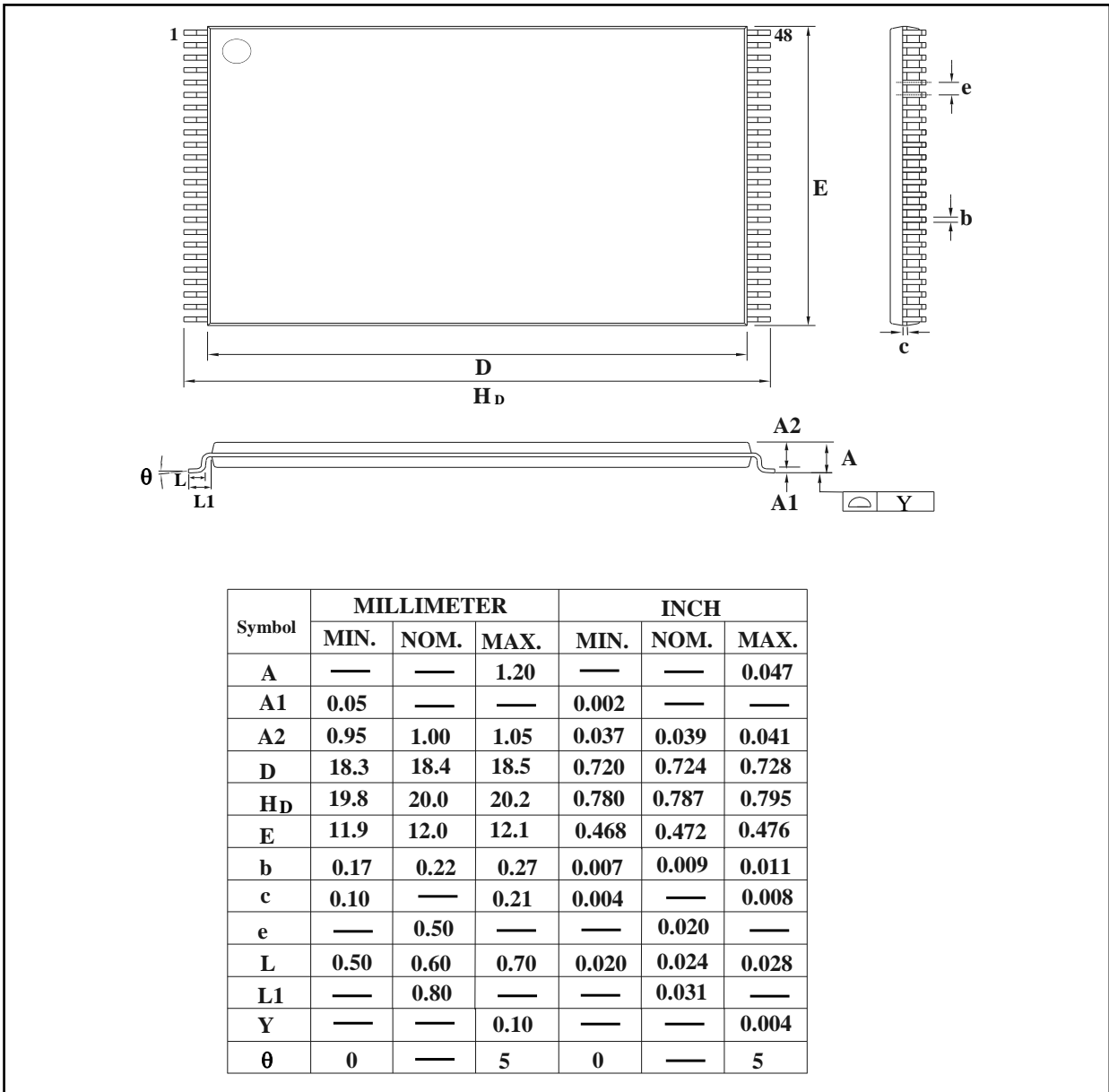

Figure 13-1 TSOP 48-PIN 12X20mm



13.2 Fine-Pitch Ball Grid Array 48-ball

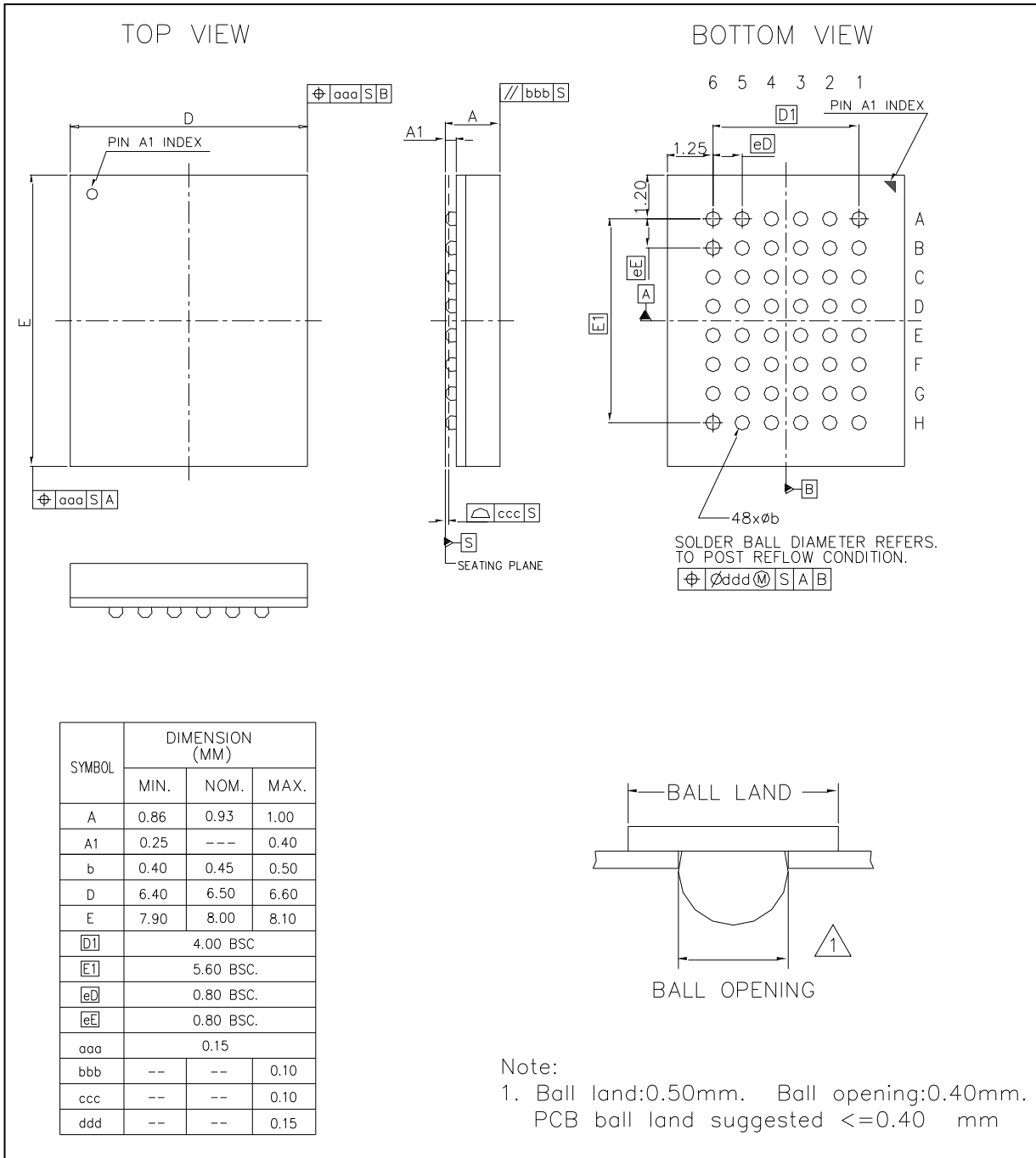

Figure 13-2 Fine-Pitch Ball Grid Array 48-Ball



13.3 Fine-Pitch Ball Grid Array 63-ball

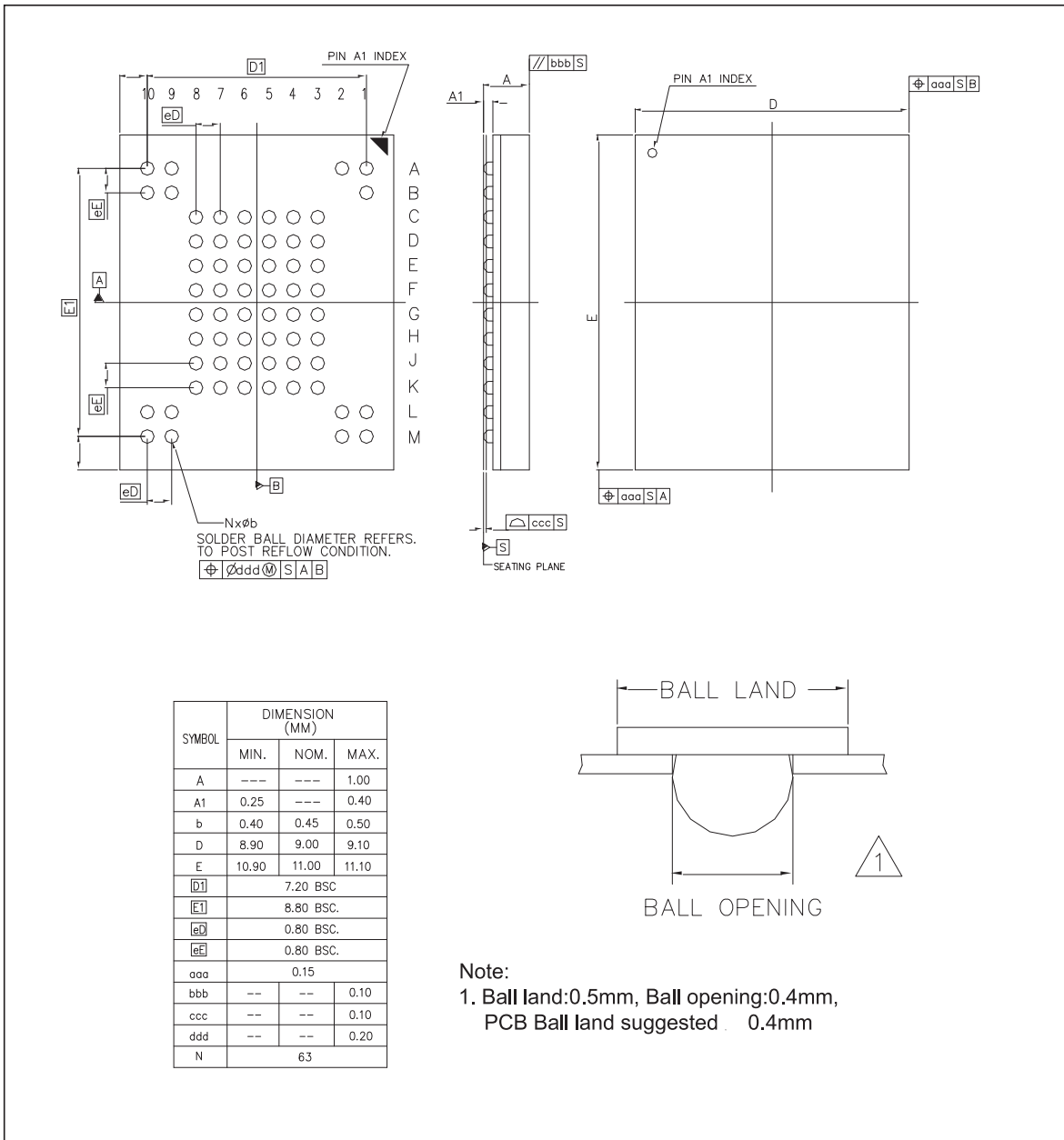

Figure 13-3 Fine-Pitch Ball Grid Array 63-Ball (9x11mm)



14. ORDERING INFORMATION

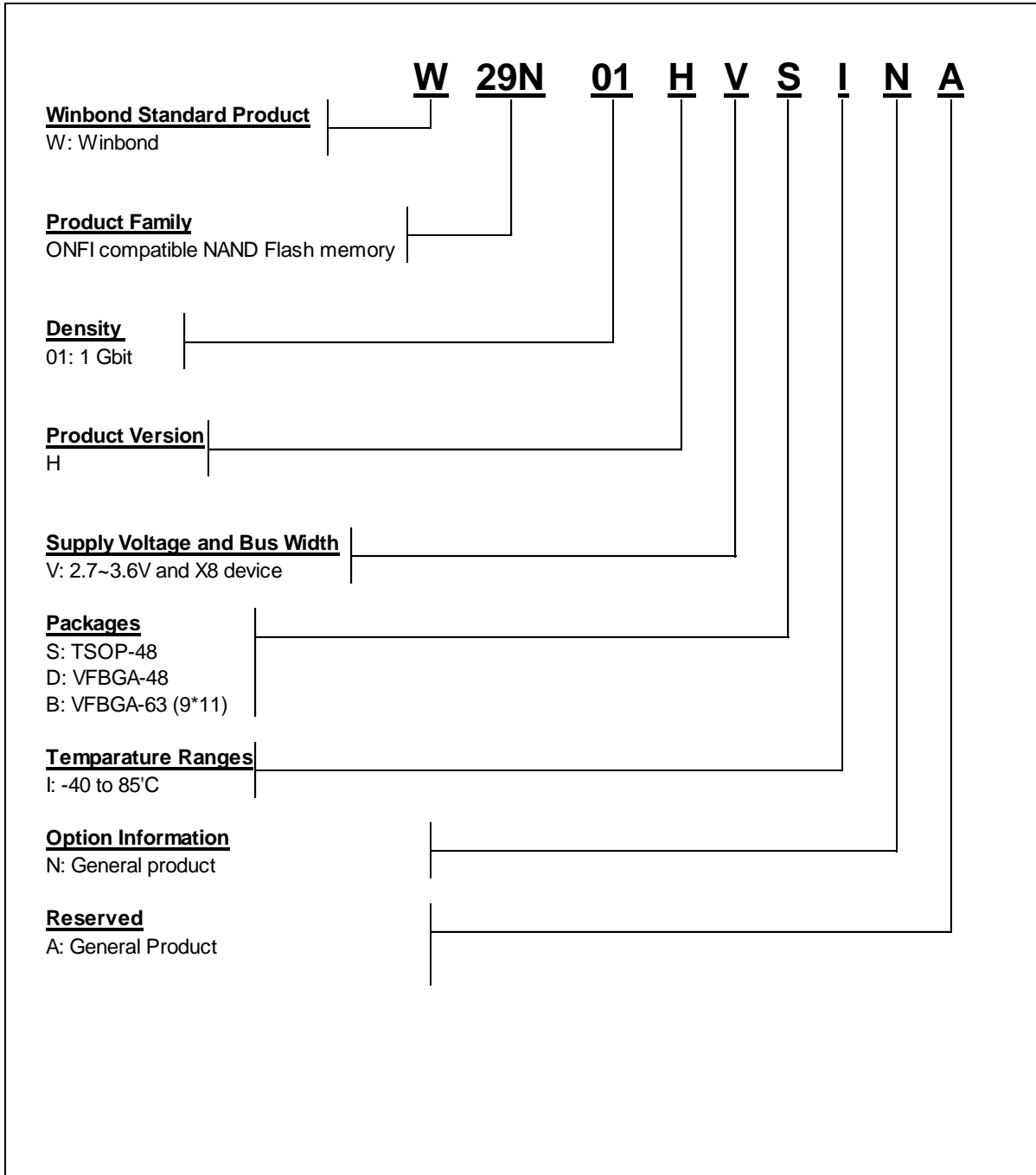

Figure 14-1 Ordering Part Number Description

**15. VALID PART NUMBERS**

The following table provides the valid part numbers for the W29N01HV NAND Flash Memory. Please contact Winbond for specific availability by density and package type. Winbond NAND Flash memories use a 12-digit Product Number for ordering.

Part Numbers for Industrial Temperature:

PACKAGE TYPE	DENSITY	VCC	BUS	PRODUCT NUMBER	TOP SIDE MARKING
S TSOP-48	1G-bit	3V	X8	W29N01HVSINA	W29N01HVSINA
D VFBGA-48	1G-bit	3V	X8	W29N01HVDINA	W29N01HVDINA
B VFBGA-63	1G-bit	3V	X8	W29N01HVBINA	W29N01HVBINA

Table 15.1 Part Numbers for Industrial Temperature



16. REVISION HISTORY

VERSION	DATE	PAGE	DESCRIPTION
0.1	06/02/15		New Create for 3.3V product spec
0.2	06/05/15		Adding 63-ball BGA package Update ordering information
0.3	07/29/15		Update ordering information
A	10/15/15		Remove Preliminary
B	12/01/17	10 19	Change description of DNU Update Parameter Page Output Value
C	01/11/18	50	Update Package Dimension of VFBGA-48

Table 16.1 History Table

Trademarks

Winbond is trademark of *Winbond Electronics Corporation*.
All other marks are the property of their respective owner.

Important Notice

Winbond products are not designed, intended, authorized or warranted for use as components in systems or equipment intended for surgical implantation, atomic energy control instruments, airplane or spaceship instruments, transportation instruments, traffic signal instruments, combustion control instruments, or for other applications intended to support or sustain life. Furthermore, Winbond products are not intended for applications wherein failure of Winbond products could result or lead to a situation where in personal injury, death or severe property or environmental damage could occur.

Winbond customers using or selling these products for use in such applications do so at their own risk and agree to fully indemnify Winbond for any damages resulting from such improper use or sales.

Please note that all data and specifications are subject to change without notice.
All the trademarks of products and companies mentioned in this datasheet belong to their respective owners.

Looking for pricing, stock, or lifecycle information?

Click below to explore more details on WIN SOURCE:

-  [View W29N01HVBINA](#) on WIN SOURCE
-  [Winbond Electronics](#) Information

Optimize Your Supply Chain with WIN SOURCE Solutions

-  Global Sourcing Solution
-  Obsolete Management
-  Cost Control Management
-  Shortage Management
-  Alternative Solution
-  Excess Inventory Management