



**THE DATASHEET OF
LTC5587IDD#TRPBF**



FEATURES

- Frequency Range: 10MHz to 6GHz
- Accurate Power Measurement of High Crest Factor (Up to 12dB) Waveforms
- 40dB Log Linear Dynamic Range
- Exceptional Accuracy Over Temperature
- Single-Ended RF Input
- 0.014dB/Bit (12-Bit) ADC Resolution ($V_{REF} = 1.8V$)
- ADC Sample Rate Up to 500ksps
- SPI/MICROWIRE Serial I/O
- Compatible with 1V to 3.6V Digital Logic
- Fast Response Time: 1 μ s Rise, 8 μ s Fall
- Low Power: 3mA at 3.3V and 500ksps
- Small 3mm \times 3mm 12-pin DFN Package

APPLICATIONS

- LTE, WiMAX, W-CDMA, TD-SCDMA, CDMA, CDMA2000, EDGE, GSM
- Pico-Cells, Femto-Cells RF Power Control
- Wireless Repeaters
- CATV/DVB Transmitters
- MIMO Wireless Access Points
- Portable RMS Power Measurement
- Antenna Monitor

DESCRIPTION

The LTC[®]5587 is a 10MHz to 6GHz, low power monolithic precision RMS power detector with an integrated 12-bit serial analog-to-digital converter (ADC). The RMS detector uses a proprietary technique to accurately measure the RF power of modulated signals with crest-factor as high as 12dB. For an input frequency of 2.14GHz the detection range is from -34 dBm to 6dBm. The serial digital output of the detector is a 12-bit word value that is directly proportional to the RF signal power measured in dBm. The LTC5587 is suitable for precision power measurement for a wide variety of RF standards, including LTE, WiMAX, W-CDMA, TD-SCDMA, CDMA, CDMA2000, EDGE, GSM, etc. The DC output of the detector is connected in series with an on-chip 300 Ω resistor to the analog output pin (V_{OUT}). This enables further filtering of the output modulation ripple using an off-chip capacitor before analog-to-digital conversion. The ADC features include no data latency, no missing codes, and a sampling rate of up to 500ksps. A dedicated external reference pin (V_{REF}) can be tied to V_{DD} or other suitable low-impedance voltage reference to set the ADC full-scale input voltage range. The ADC also features an automatic power down after each conversion making the LTC5587 ideal for low-power applications.

LT, LT, LTC, LTM, Linear Technology and the Linear logo are registered trademarks of Linear Technology Corporation. All other trademarks are the property of their respective owners.

BLOCK DIAGRAM

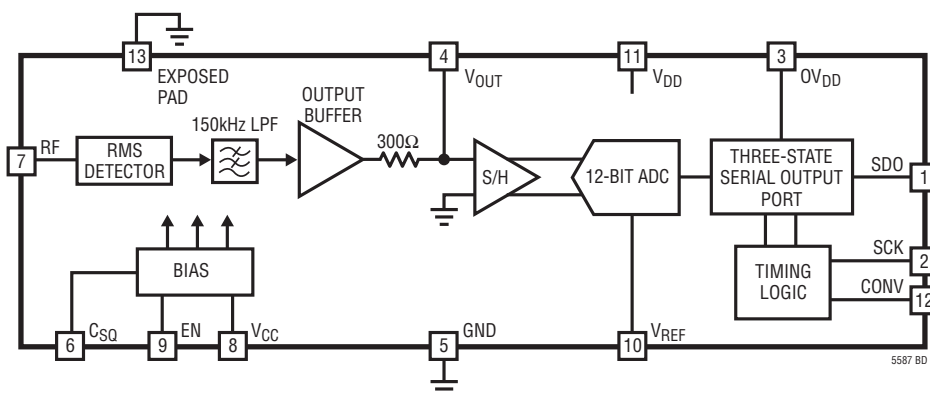

**Linearity Error vs RF Input Power
2140MHz Modulated Waveforms**

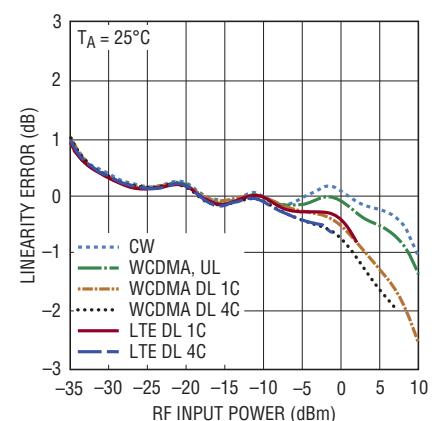

5587 G12

5587f

ABSOLUTE MAXIMUM RATINGS

(Note 1)

V_{DD} , V_{CC} Voltage, (Note 12)	4V
OV_{DD} Supply Voltage	Min($V_{DD} + 0.3V$, 4V)
Maximum Input Signal Power (Average)	15dBm
Maximum Input Signal Power (Peak)	25dBm
DC Voltage at RF	-0.3V to 2V
V_{OUT} Voltage	-0.3V to $V_{DD} + 0.3V$
EN Voltage	-0.3V to $V_{DD} + 0.3V$
SDO, SCK, CONV Voltage	-0.3V to $V_{DD} + 0.3V$
V_{REF} Voltage	-0.3V to $V_{DD} + 0.3V$
Power Dissipation	100mW
Maximum Junction Temperature, T_{JMAX}	150°C
Operating Temperature Range (Note 2)	-40°C to 85°C
Storage Temperature Range	-65°C to 150°C

PIN CONFIGURATION

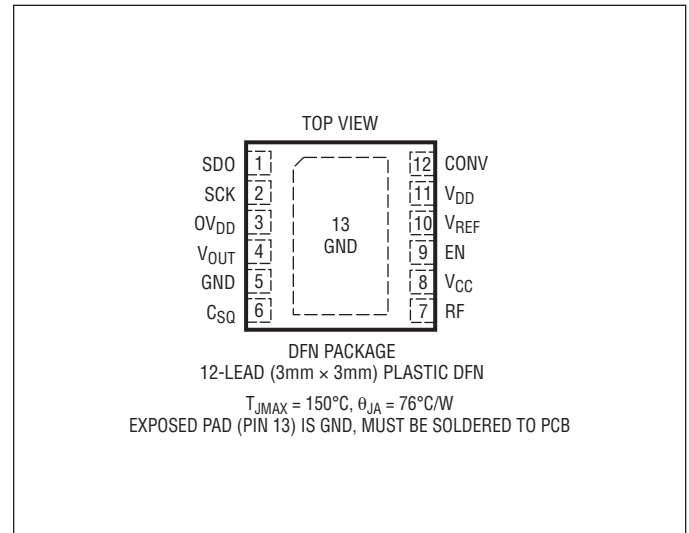

Caution: This part is sensitive to electrostatic discharge. It is very important that proper ESD precautions be observed when handling the LTC5587.

ORDER INFORMATION

LEAD FREE FINISH	TAPE AND REEL	PART MARKING	PACKAGE DESCRIPTION	TEMPERATURE RANGE
LTC5587IDD#PBF	LTC5587IDD#TRPBF	LFRH	12-Lead (3mm × 3mm) Plastic DFN	-40°C to 85°C

Consult LTC Marketing for parts specified with wider operating temperature ranges.

Consult LTC Marketing for information on non-standard lead based finish parts.

For more information on lead free part marking, go to: <http://www.linear.com/leadfree/>

For more information on tape and reel specifications, go to: <http://www.linear.com/tapeandreel/>

ELECTRICAL CHARACTERISTICS The ● denotes the specifications which apply over the full operating temperature range, otherwise specifications are at $T_A = 25^{\circ}C$ (Note 2). $V_{CC} = V_{DD} = OV_{DD} = 3.3V$, $V_{REF} = 1.8V$, $EN = 3.3V$, $f_{SMPL} = f_{SMPL(MAX)}$ and $f_{SCK} = f_{SCK(MAX)}$ unless otherwise noted. Test circuit is shown in Figure 1.

PARAMETER	CONDITIONS	MIN	TYP	MAX	UNITS
RF Input					
Input Frequency Range (Note 4)			10 to 6000		MHz
Input Impedance			205 1.6		Ω pF
$f_{RF} = 450MHz$					
RF Input Power Range	Externally Matched to 50 Ω Source		-34 to 6		dBm
Linear Dynamic Range, CW (Note 3)	$\pm 1dB$ Linearity Error		40		dB
Linear Dynamic Range, CDMA (Note 3)	$\pm 1dB$ Linearity Error; CDMA 4-Carrier		40		dB
Output Slope			73		LSB/dB
Logarithmic Intercept (Note 5)			-42		dBm
Output Variation vs Temperature	Normalized to Output at 25°C; $P_{IN} = -34dBm$ to 6dBm		± 1		dB

ELECTRICAL CHARACTERISTICS The ● denotes the specifications which apply over the full operating temperature range, otherwise specifications are at $T_A = 25^\circ\text{C}$ (Note 2). $V_{CC} = V_{DD} = 0V_{DD} = 3.3V$, $V_{REF} = 1.8V$, $EN = 3.3V$, $f_{SMPL} = f_{SMPL(MAX)}$ and $f_{SCK} = f_{SCK(MAX)}$ unless otherwise noted. Test circuit is shown in Figure 1.

PARAMETER	CONDITIONS	MIN	TYP	MAX	UNITS
Output Variation vs Temperature	Normalized to Output at 25°C ; $P_{IN} = -27\text{dBm}$ to -10dBm		± 0.5		dB
Deviation from CW Response; $P_{IN} = -34\text{dBm}$ to 0dBm	TETRA $\pi/4$ DQPSK CDMA 4-Carrier 64-Channel Fwd 1.23Mcps		± 0.1 ± 0.5		dB dB
2nd Order Harmonic Distortion	At RF Input; CW Input; $P_{IN} = 0\text{dBm}$		-57		dBc
3rd Order Harmonic Distortion	At RF Input; CW Input; $P_{IN} = 0\text{dBm}$		-52		dBc
$f_{RF} = 880\text{MHz}$					
RF Input Power Range	CW Input: Externally Matched to 50Ω Source		-34 to 6		dBm
Linear Dynamic Range, CW (Note 3)	$\pm 1\text{dB}$ Linearity Error		40		dB
Linear Dynamic Range, EDGE (Note 3)	$\pm 1\text{dB}$ Linearity Error; EDGE $3\pi/8$ -Shifted 8PSK		40		dB
Output Slope			73		LSB/dB
Logarithmic Intercept (Note 5)			-42		dBm
Output Variation vs Temperature	Normalized to Output at 25°C ; $P_{IN} = -34\text{dBm}$ to 6dBm		± 1		dB
Output Variation vs Temperature	Normalized to Output at 25°C ; $P_{IN} = -27\text{dBm}$ to -10dBm		± 0.5		dB
Deviation from CW Response; $P_{IN} = -34\text{dBm}$ to 6dBm	EDGE $3\pi/8$ Shifted 8PSK		± 0.1		dB
$f_{RF} = 2140\text{MHz}$					
RF Input Power Range	CW Input: Externally Matched to 50Ω Source		-34 to 6		dBm
Linear Dynamic Range, CW (Note 3)	$\pm 1\text{dB}$ Linearity Error		43		dB
Linear Dynamic Range, WCDMA (Note 3)	$\pm 1\text{dB}$ Linearity Error; 4-Carrier WCDMA		37		dB
Output Slope			73		LSB/dB
Logarithmic Intercept (Note 5)			-42		dBm
Output Variation vs Temperature	Normalized to Output at 25°C ; $P_{IN} = -34\text{dBm}$ to 6dBm		± 1		dB
Output Variation vs Temperature	Normalized to Output at 25°C ; $P_{IN} = -27\text{dBm}$ to -10dBm		± 0.5		dB
Deviation from CW Response; $P_{IN} = -34\text{dBm}$ to -4dBm	WCDMA 1-Carrier Uplink WCDMA 64-Channel 4-Carrier Downlink		± 0.1 ± 0.5		dB dB
$f_{RF} = 2600\text{MHz}$					
RF Input Power Range	CW Input: Externally Matched to 50Ω Source		-34 to 6		dBm
Linear Dynamic Range, CW (Note 3)	$\pm 1\text{dB}$ Linearity Error		40		dB
Output Slope			73		LSB/dB
Logarithmic Intercept (Note 5)			-42		dBm
Output Variation vs Temperature	Normalized to Output at 25°C ; $P_{IN} = -34\text{dBm}$ to 6dBm		± 1		dB
Output Variation vs Temperature	Normalized to Output at 25°C ; $P_{IN} = -27\text{dBm}$ to -10dBm		± 0.5		dB
Deviation from CW Response; $P_{IN} = -34\text{dBm}$ to 2dBm	WiMax OFDMA Preamble WiMax OFDM Burst		± 0.1 ± 0.5		dB dB
$f_{RF} = 3500\text{MHz}$					
RF Input Power Range	CW Input: Externally Matched to 50Ω Source		-30 to 6		dBm
Linear Dynamic Range, CW (Note 3)	$\pm 1\text{dB}$ Linearity Error		36		dB
Output Slope			73		LSB/dB
Logarithmic Intercept (Note 5)			-40		dBm

ELECTRICAL CHARACTERISTICS The ● denotes the specifications which apply over the full operating temperature range, otherwise specifications are at $T_A = 25^\circ\text{C}$ (Note 2). $V_{CC} = V_{DD} = 0V_{DD} = 3.3V$, $V_{REF} = 1.8V$, $EN = 3.3V$, $f_{SMPL} = f_{SMPL(MAX)}$ and $f_{SCK} = f_{SCK(MAX)}$ unless otherwise noted. Test circuit is shown in Figure 1.

PARAMETER	CONDITIONS	MIN	TYP	MAX	UNITS
Output Variation vs Temperature	Normalized to Output at 25°C ; $P_{IN} = -30\text{dBm}$ to 6dBm		± 1		dB
Output Variation vs Temperature	Normalized to Output at 25°C ; $P_{IN} = -27\text{dBm}$ to -10dBm		± 0.5		dB
Deviation from CW Response; $P_{IN} = -34\text{dBm}$ to -4dBm	WiMax OFDMA Preamble WiMax OFDM Burst		± 0.1 ± 0.5		dB dB

Detector Analog Output

Output DC Voltage at V_{OUT}	No Signal Applied to RF Input		180		mV
Output Impedance	Internal Series Resistor Allows for Off-Chip Filter Cap		300		Ω
Output Current Sourcing/Sinking			5/5		mA
Rise Time (1000pF on V_{OUT})	0.2V to 1.6V, 10% to 90%, $f_{RF} = 2140\text{MHz}$		1		μsec
Fall Time (1000pF on V_{OUT})	1.6V to 0.2V, 10% to 90%, $f_{RF} = 2140\text{MHz}$		8		μsec
Power Supply Rejection Ratio (Note 6)	For CW RF Input Over Operating Input Power Range		49		dB
Integrated Output Voltage Noise	1 to 6.5 kHz Integration BW, $P_{IN} = 0\text{dBm}$ CW		150		μV_{RMS}
Peak-to-Peak ADC Output Noise	$C_{FILT} = 1000\text{pF}$, $P_{IN} = 0\text{dBm}$ CW		11		LSB

ADC Resolution

ADC Resolution	(No Missing Codes)	●	12		Bits
Differential Linearity Error	$EN = 0V$, Voltage on $V_{OUT} = 0V$ to $1.8V$, $V_{REF} = 1.8V$	●	± 0.25	± 1	LSB
Measurement Resolution	$1\text{LSB} = V_{REF}/(4096 \cdot 32\text{mV/dB})$, $V_{REF} = 1.8V$		0.014		dB/Bit

ADC Digital Timing

SYMBOL	PARAMETER	CONDITIONS	MIN	TYP	MAX	UNITS
$f_{SAMPL(MAX)}$	Maximum Sampling Frequency	(Notes 8, 9)	●	500		kHz
f_{SCK}	Shift Clock Frequency	(Notes 8, 9)	●		50	MHz
t_{SCK}	Shift Clock Period		●	20		ns
$t_{THROUGHPUT}$	Minimum Throughput Time, $t_{ACQ} + t_{CONV}$		●		2	μs
t_{ACQ}	Acquisition Time		●	0.5		μs
t_{CONV}	Conversion Time		●	1.5		μs
t_1	Minimum Positive CONV Pulse Width	(Note 8)	●	1.5		μs
t_2	SCK \uparrow Setup Time After CONV \downarrow	(Note 8)	●	16		ns
t_3	SDO Enabled Time After CONV \downarrow	(Notes 8, 9)	●		16	ns
t_4	SDO Data Valid Access Time After SCK \downarrow	(Notes 8, 9, 10)	●		8	ns
t_5	SCK Low Time	(Note 7)	●	40%		t_{SCK}
t_6	SCK High Time	(Note 7)	●	40%		t_{SCK}
t_7	SDO Data Valid Hold Time After SCK \downarrow	(Notes 8, 9, 10)	●	4		ns
t_8	SDO Into Hi-Z State Time After CONV \uparrow	(Notes 8, 9)			6	ns

ADC Digital Inputs and Outputs

SYMBOL	PARAMETER	CONDITIONS	MIN	TYP	MAX	UNITS
V_{IH}	SCK, CONV Logic High Input		●	2		V
V_{IL}	SCK, CONV Logic Low Input		●		0.8	V
I_{IH}	Logic High Input Current	SCK, CONV = V_{DD}	●		2.5	μA
I_{IL}	Logic Low Input Current	SCK, CONV = $0V$	●	-2.5		μA

ELECTRICAL CHARACTERISTICS The ● denotes the specifications which apply over the full operating temperature range, otherwise specifications are at $T_A = 25^\circ\text{C}$ (Note 2). $V_{CC} = V_{DD} = 0V_{DD} = 3.3V$, $V_{REF} = 1.8V$, $EN = 3.3V$, $f_{SMPL} = f_{SMPL(MAX)}$ and $f_{SCK} = f_{SCK(MAX)}$ unless otherwise noted. Test circuit is shown in Figure 1.

SYMBOL	PARAMETER	CONDITIONS	MIN	TYP	MAX	UNITS
C_{IN}	SCK, CONV Input Capacitance			2		pF
V_{OH}	SDO Logic High Output	$I_{SOURCE} = 200\mu\text{A}$	●	$V_{DD} - 0.2$		V
V_{OL}	SDO Logic Low Output	$I_{SINK} = 200\mu\text{A}$	●		0.2	V
I_{OZ}	Hi-Z Output Leakage	$CONV = V_{DD}$	●		± 3	μA
C_{OZ}	Hi-Z Output Capacitance	$CONV = V_{DD}$		4		pF
I_{SOURCE}	SDO Source Current	SDO Connected to GND = 0V		-10		mA
I_{SINK}	SDO Sink Current	SDO Connected to V_{DD}		10		mA

Detector Enable (EN) Low = Off, High = On

PARAMETER	CONDITIONS	MIN	TYP	MAX	UNITS
EN Input High Voltage (On)		●	2		V
EN Input Low Voltage (Off)		●		0.3	V
Enable Pin Input Current	$EN = 3.3V$		25		μA
Turn ON Time; CW RF Input	V_{OUT} within 10% of Final Value; $P_{IN} = 0\text{dBm}$		1		μs
Turn OFF Time; CW RF Input	$V_{OUT} < 0.18V$; $P_{IN} = 0\text{dBm}$		8		μs

Power Supply

$0V_{DD}$ Supply Voltage		●	1	3.3	V_{DD}	V
V_{DD} Supply Voltage		●	2.7	3.3	3.6	V
V_{REF} Reference Voltage		●	1.4		$V_{DD} + 0.05$	V
V_{CC} Supply Voltage	Should Be Equal to V_{DD}	●	2.7	3.3	3.6	V
Total Supply Current	No RF Input Signal, ADC Operational at 500ksps	●		3	4	mA
	No RF Input Signal, ADC Sleep-Mode	●		1.4	2.5	mA
Shutdown Current	$EN = 0.3V$, $CONV = 3.3V$, ADC Sleep-Mode			0.2	10	μA

Note 1: Stresses beyond those listed under Absolute Maximum Ratings may cause permanent damage to the device. Exposure to any Absolute Maximum Rating condition for extended periods may affect device reliability and lifetime. The maximum RF input power rating is guaranteed by design and engineering characterization, but not production tested.

Note 2: The LTC5587 is guaranteed to be functional over the operating temperature range from -40°C to 85°C .

Note 3: The linearity error is calculated by the difference between the incremental slope of the output and the average output slope from -20dBm to 0dBm . The dynamic range is defined as the range over which the linearity error is within $\pm 1\text{dB}$.

Note 4: An external capacitor at the C_{SQ} pin should be used for input frequencies below 250MHz. Without this capacitor, lower frequency operation results in excessive RF ripple in the output voltage.

Note 5: Logarithmic intercept is an extrapolated input power level from the best fitted log-linear straight line, where the converted output code is 0LSB.

Note 6: PSRR determined as the dB value of the change in converted output voltage over the change in V_{CC} supply voltage at a given CW input power level.

Note 7: Guaranteed by design not subject to test.

Note 8: Guaranteed by characterization. All input signals are specified with $t_R = t_F = 2\text{ns}$ (10% to 90% of V_{DD}) and timed from a voltage level of 1.6V.

Note 9: All timing specifications given are with a 10pF capacitance load. With a capacitance load greater than this value, a digital buffer or latch must be used.

Note 10: The time required for the output to cross the V_{IH} or V_{IL} voltage.

Note 11: When pins V_{OUT} and V_{REF} are taken below GND or above V_{DD} , they will be clamped by internal diodes. This product can handle input currents greater than 100mA below GND or above V_{DD} without latchup.

Note 12: The V_{DD} supply voltage can be the same as V_{CC} and the pins can share a common bypass capacitor of 2.2 μF .

TYPICAL PERFORMANCE CHARACTERISTICS $V_{CC} = V_{DD} = 0V_{DD} = 3.3V$, $V_{REF} = 1.8V$, $EN = 3.3V$, $f_{SMP} = f_{SMP}(MAX)$ and $f_{SCK} = f_{SCK}(MAX)$ unless otherwise noted. $V_{OUT} = ADC \text{ Output (LSB)} \cdot 1.8/4096$. Test circuit is shown in Figure 1.

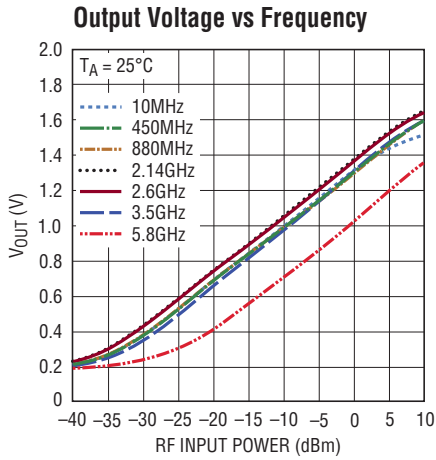

5587 G01

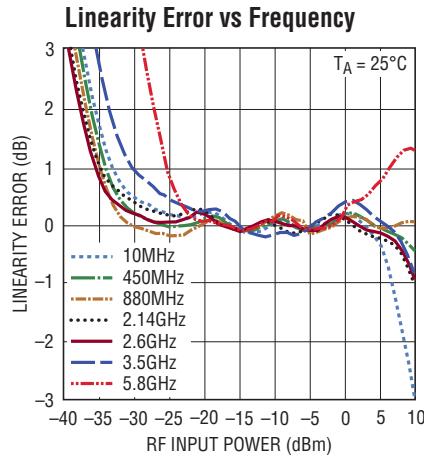

5587 G02

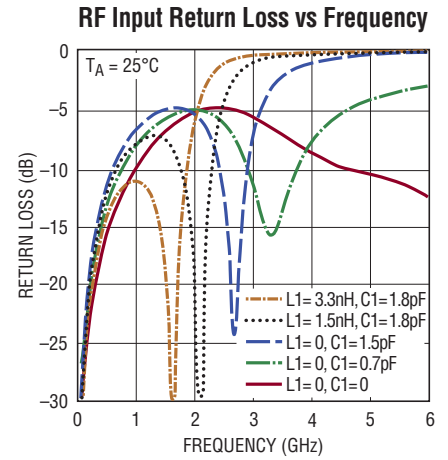

5587 G03

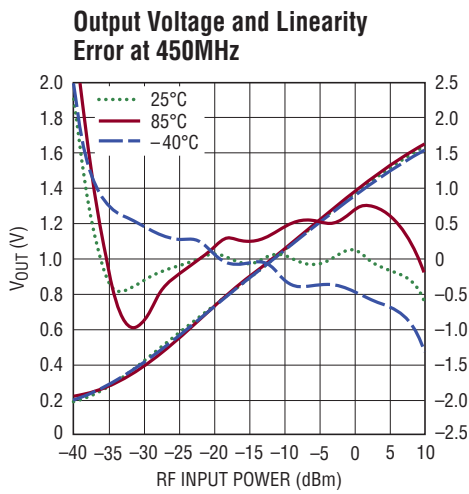

5587 G04

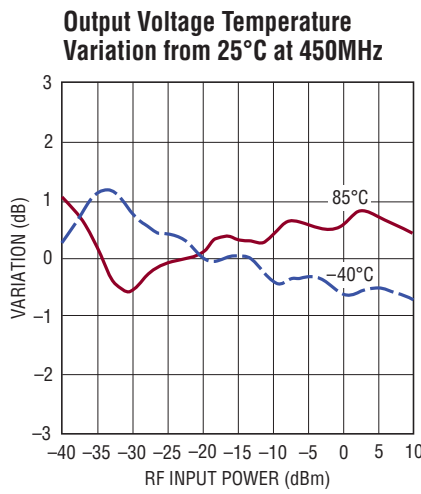

5587 G05

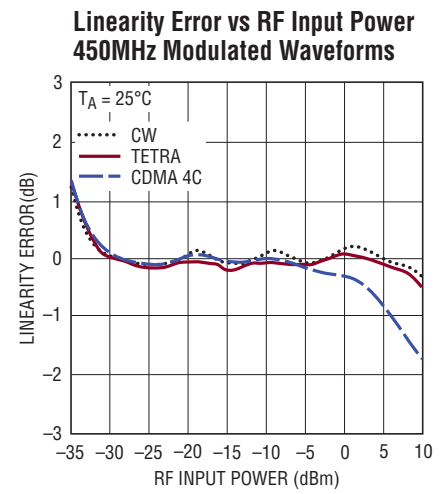

5587 G06

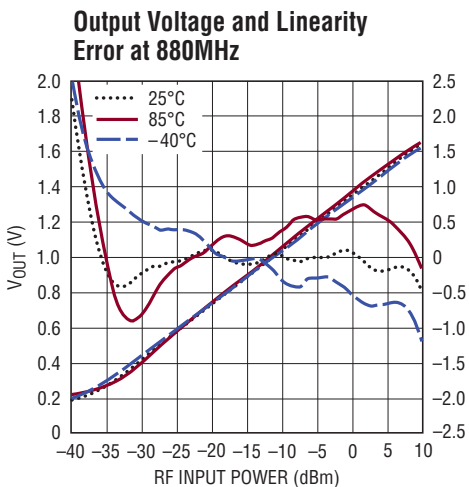

5587 G07

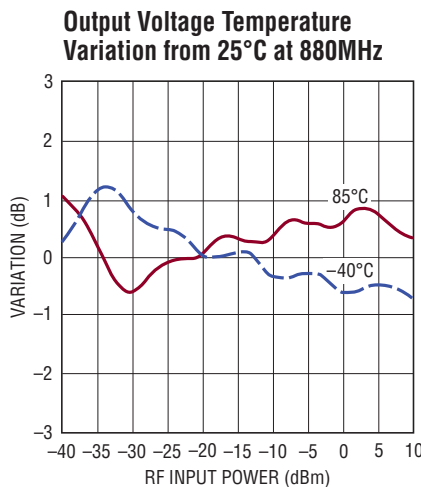

5587 G08

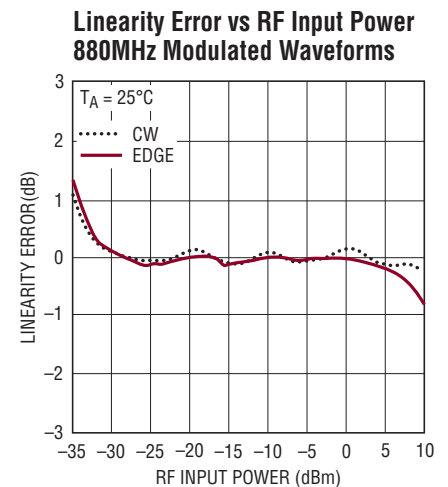

5587 G09

TYPICAL PERFORMANCE CHARACTERISTICS $V_{CC} = V_{DD} = 0V_{DD} = 3.3V$, $V_{REF} = 1.8V$, $EN = 3.3V$, $f_{SMPL} = f_{SMPL(MAX)}$ and $f_{SCK} = f_{SCK(MAX)}$ unless otherwise noted. $V_{OUT} = ADC \text{ Output (LSB)} \cdot 1.8/4096$. Test circuit is shown in Figure 1.

Output Voltage and Linearity Error at 2140MHz

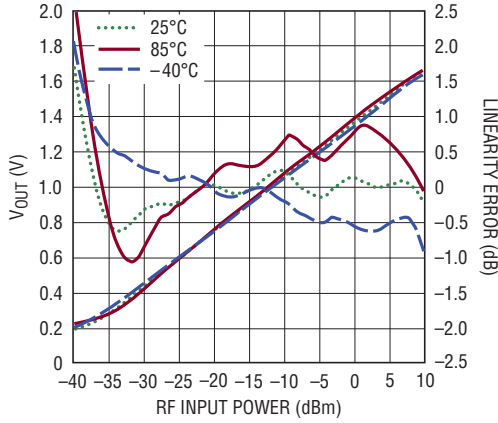

5587 G10

Output Voltage Temperature Variation from 25°C at 2140MHz

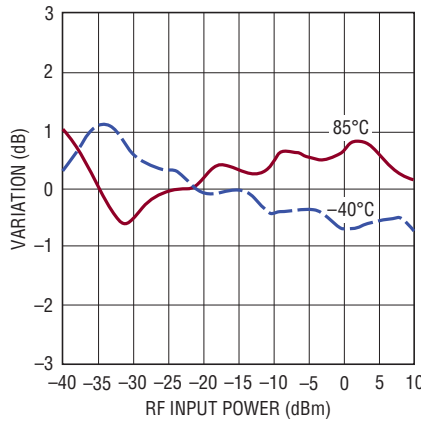

5587 G11

Linearity Error vs RF Input Power 2140MHz Modulated Waveforms

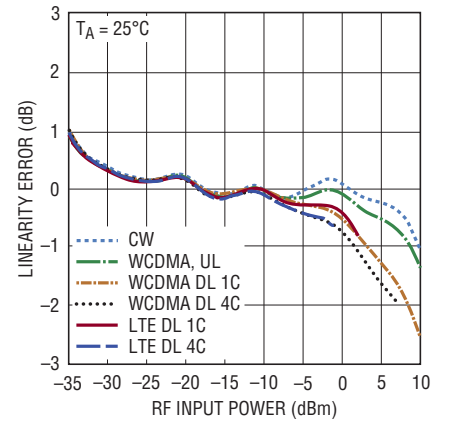

5587 G12

Output Voltage and Linearity Error at 2600MHz

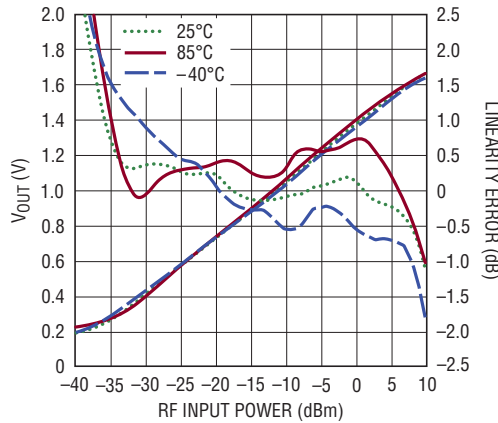

5587 G13

Output Voltage Temperature Variation from 25°C at 2600 MHz

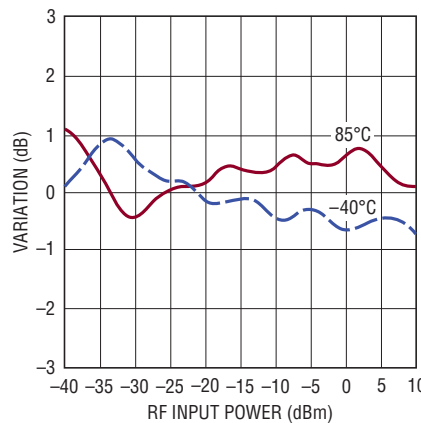

5587 G14

Linearity Error vs RF Input Power 2.6GHz Modulated Waveforms

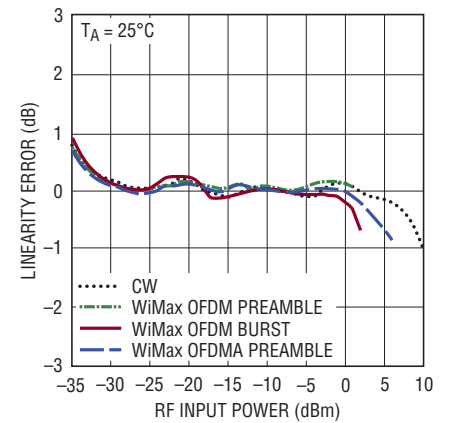

5587 G15

Output Voltage and Linearity Error at 3500MHz

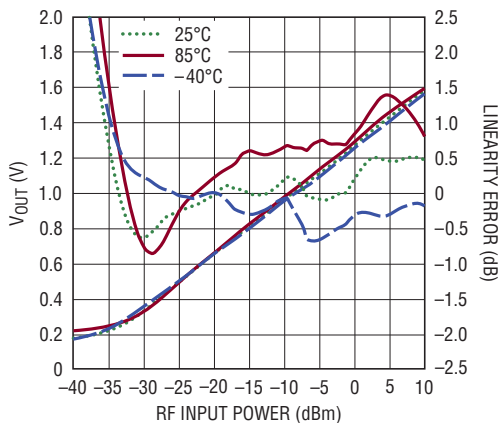

5587 G16

Output Voltage Temperature Variation from 25°C at 3500MHz

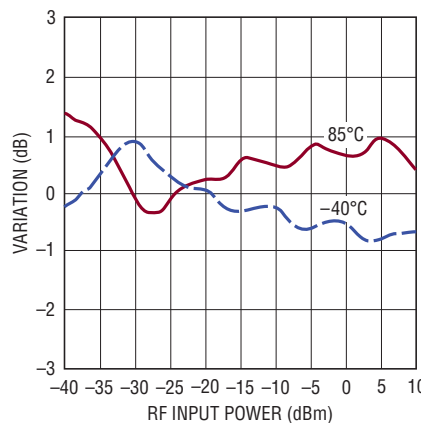

5587 G17

Linearity Error vs RF Input Power 3.5GHz Modulated Waveforms

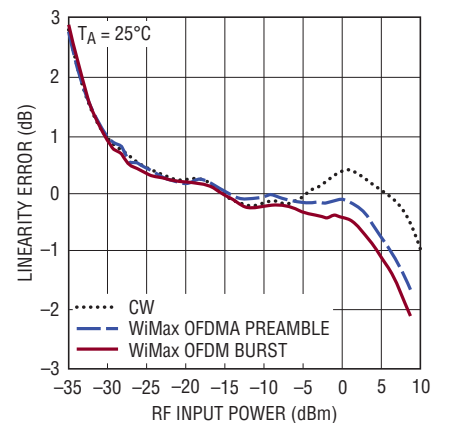

5587 G18

TYPICAL PERFORMANCE CHARACTERISTICS

$V_{CC} = V_{DD} = OV_{DD} = 3.3V$, $V_{REF} = 1.8V$, $EN = 3.3V$, $f_{SMPL} = f_{SMPL(MAX)}$ and $f_{SCK} = f_{SCK(MAX)}$ unless otherwise noted. $V_{OUT} = ADC \text{ Output (LSB)} \cdot 1.8/4096$. Test circuit is shown in Figure 1.

Output Voltage and Linearity Error at 5800MHz

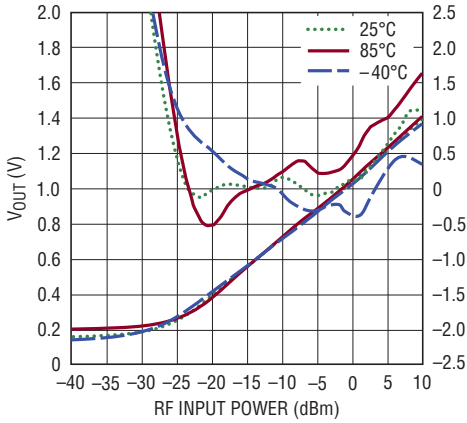

5587 G19

Output Voltage Temperature Variation from 25°C at 5800MHz

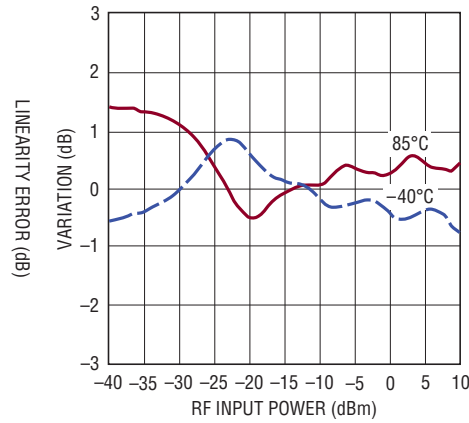

5587 G20

Linearity Error vs RF Input Power 5.8GHz Modulated Waveforms

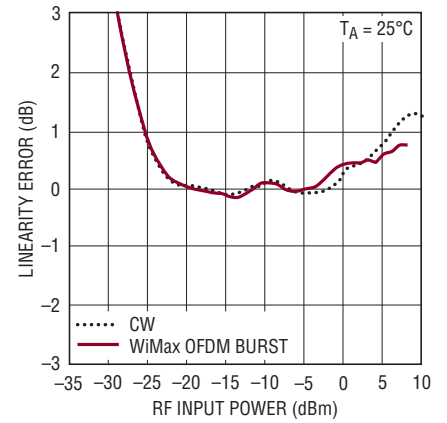

5587 G21

Slope vs Frequency

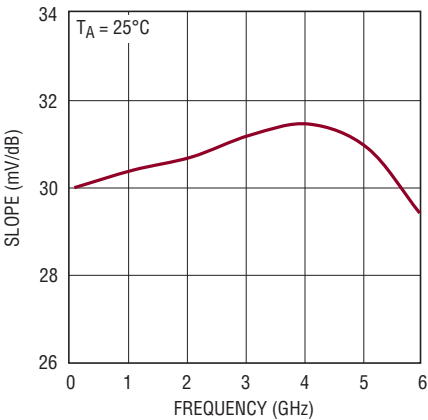

5587 G23

Slope Distribution vs Temperature

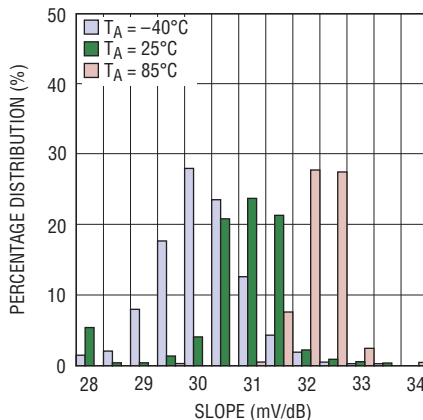

5587 G24

Supply Current vs Supply Voltage

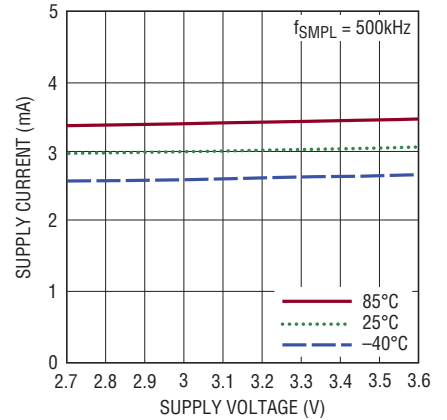

5587 G25

Logarithmic Intercept vs Frequency

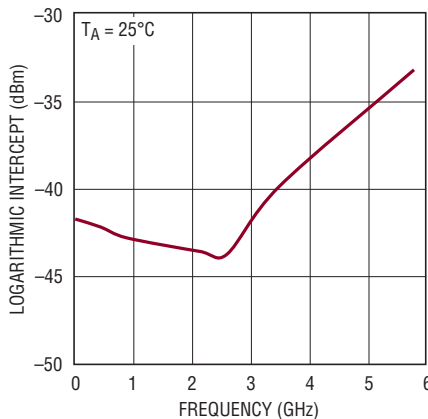

5587 G26

Logarithmic Intercept Distribution vs Temperature

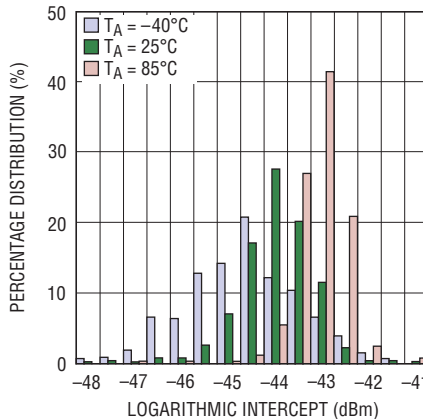

5587 G27

Total Supply Current vs RF Input Power and Sample Rate

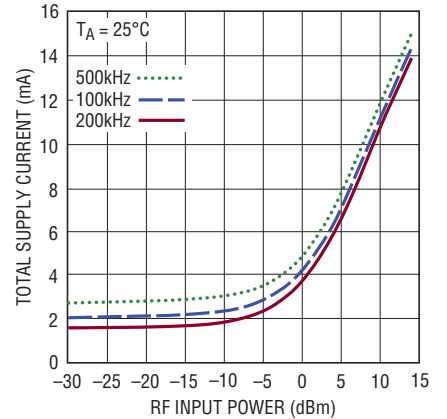

5587 G28

TYPICAL PERFORMANCE CHARACTERISTICS $V_{CC} = V_{DD} = 0V_{DD} = 3.3V$, $V_{REF} = 1.8V$, $EN = 3.3V$, $f_{SAMPL} = f_{SAMPL(MAX)}$ and $f_{SCK} = f_{SCK(MAX)}$ unless otherwise noted. $V_{OUT} = ADC \text{ Output (LSB)} \cdot 1.8/4096$. Test circuit is shown in Figure 1.

Output Voltage and Linearity Error vs V_{CC} at 2140MHz

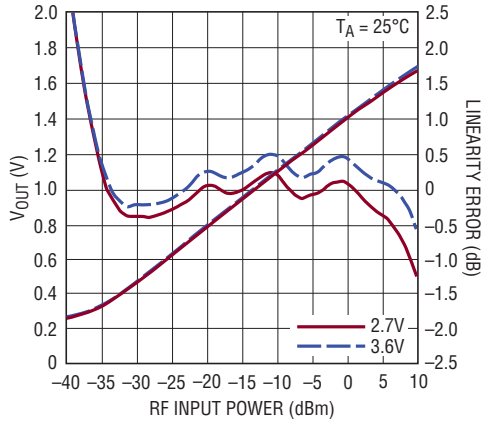

5587 G29

Output Transient Response with CW RF and EN Pulse

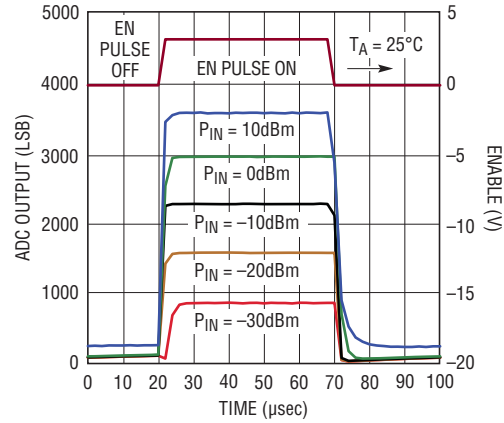

5587 G33

Output Transient Response

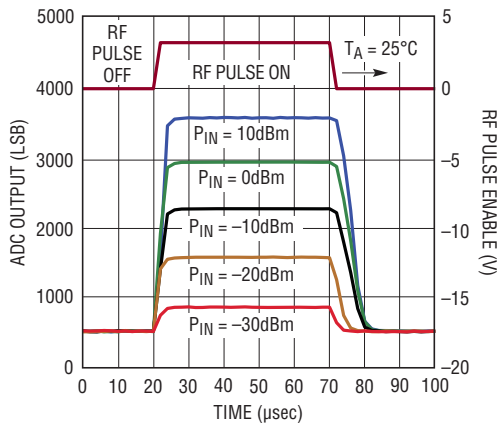

5587 G32

Output Transient Response with RF Pulse and EN Pulse

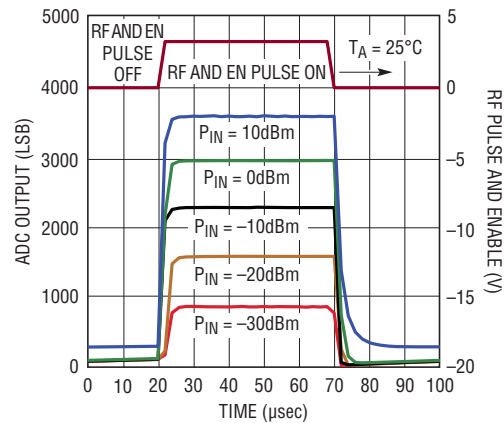

5587 G31

PIN FUNCTIONS

SDO (Pin 1): Three-State Serial Data Output. The A/D conversion result is shifted out on SDO as a serial data stream with MSB first. The data stream consists of 12 bits of conversion data followed by trailing zeros.

SCK (Pin 2): Shift Clock Input. The SCK serial clock synchronizes the serial data transfer. SDO data transitions on the falling edge of SCK.

OV_{DD} (Pin 3): ADC Output Driver Supply Voltage, 1.0V to 3.6V. OV_{DD} should be bypassed with a 1 μ F ceramic capacitor. OV_{DD} can be driven separately from V_{DD} and OV_{DD} can be higher than V_{DD}.

V_{OUT} (Pin 4): Detector Analog Voltage Output. An internal series 300 Ω resistor at the detector output allows for simple R-C filtering with a capacitor placed on this pin to GND. A 1000pF capacitor is recommended for a corner frequency of 500kHz.

C_{SQ} (Pin 6): Optional low-frequency range extension capacitor for frequencies below 250MHz. Connect 0.01 μ F from this pin to ground for 10MHz operation.

RF (Pin 7): RF Input Voltage. Should be externally DC-blocked. A capacitor of 1000pF is recommended. This pin has an internal 205 Ω termination.

V_{CC} (Pin 8): Detector Power Supply Voltage, 2.7V to 3.6V. Can be connected to the V_{DD} voltage supply. V_{CC} should be bypassed with a 1 μ F ceramic capacitor. If V_{CC} and V_{DD} are tied together, then bypass with 2.2 μ F.

EN (Pin 9): Detector Enable. A logic low or no-connect on the enable pin shuts down the detector. A logic high enables the detector. An internal 500k pull-down resistor ensures the detector is off when the pin is left floating.

V_{REF} (Pin 10): ADC Reference Input Voltage. V_{REF} defines the input span of the ADC, 0V to V_{REF}. The V_{REF} range is 1.4V to V_{DD}. Bypass to ground with a 1 μ F ceramic capacitor.

V_{DD} (Pin 11): ADC Power Supply Voltage, 2.7V to 3.6V. V_{DD} should be bypassed with a 1 μ F ceramic capacitor.

CONV (Pin 12): Convert Input. This active high signal starts a conversion on the rising edge. The ADC automatically powers down after conversion. A logic low on this input enables the SDO pin, allowing the data to be shifted out.

GND (Pin 5, Exposed Pad Pin 13): Ground. For high-frequency operation, backside ground connection should have a low-inductance connection to the pcb ground using many through-hole vias. See layout information.

BLOCK DIAGRAM

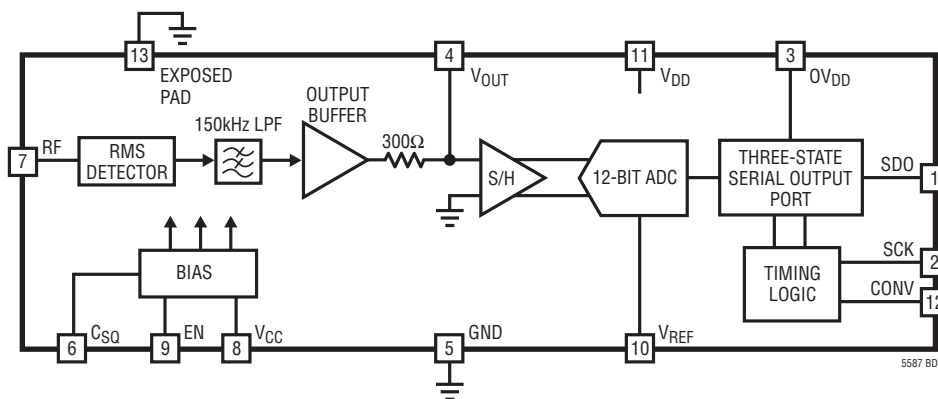

5587 BD

TIMING DIAGRAMS

SDO Into Hi-Z State After CONV Rising Edge

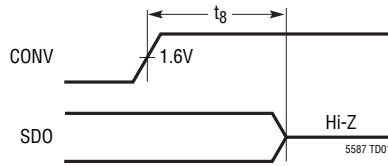

SDO Data Valid Hold Time After SCK Falling Edge

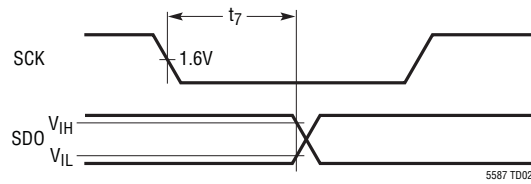

SDO Data Valid Access Time After SCK Falling Edge

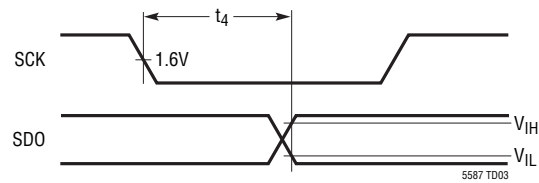

TEST CIRCUIT

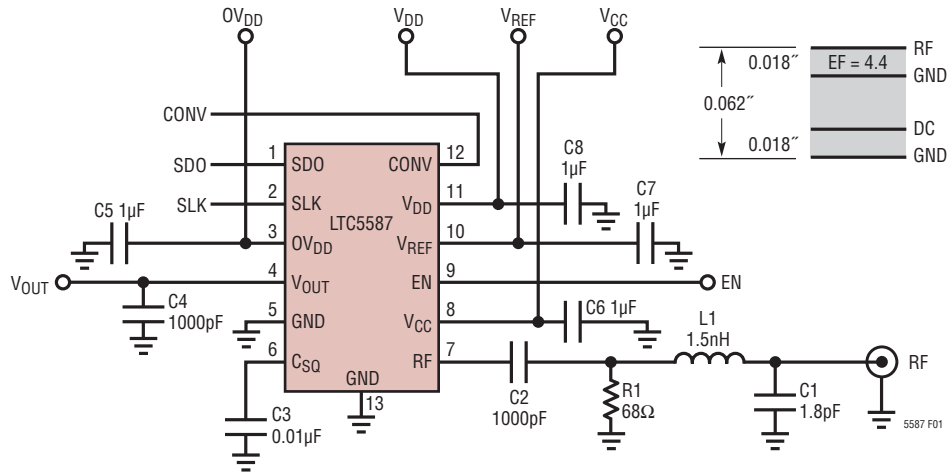

REF DES	VALUE	SIZE	PART NUMBER
C5, C6, C7, C8	1µF	0402	AVX 0402ZG105ZAT2A
C3	0.01µF	0402	AVX 04023C103KAT2A
C2, C4	1000pF	0402	AVX 04025C102KAT2A
R1	68Ω	0402	CRCW040268R1FKED

FREQUENCY RANGE	RF _{IN} MATCH	
	L1	C1
0.04 to 1.8GHz	3.3nH	1.8pF
1.75 to 2.2GHz	1.5nH	1.8pF
2.4 to 2.9GHz	0	1.5pF
2.8 to 3.8GHz	0	0.7pF
4.5 to 6.0GHz	0	0

Figure 1. Evaluation Circuit Schematic

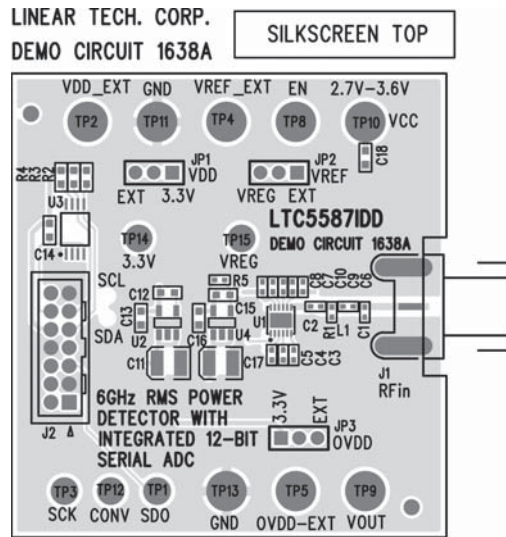

Figure 2. Evaluation Circuit Board

APPLICATIONS INFORMATION

Operation

The LTC5587 combines a proprietary high-speed power detector with an internal 150kHz lowpass averaging filter and a true 12-bit successive approximation ADC with a serial output interface. It can accurately measure the RMS power of high crest-factor modulated RF signals. The output voltage of the RF power detector is converted to a 12-bit digital word that is directly proportional to the average RF input power in dBm. The part can be operated from a single supply or dedicated supplies, allowing the user to select a specific voltage range for the ADC conversion in addition to interfacing with 1.8V, 2.5V, or 3V digital systems.

Evaluation

Figure 1 shows the simplified evaluation circuit schematic, and Figure 2 shows the associated board artwork. To ensure proper operation, good grounding practice should be followed in the board layout, with liberal placement of vias under the exposed pad of the package and around signal and digital lines. The evaluation board shown in Figure 2 contains additional support circuitry not shown in Figure 1 that includes an optional 3.3V regulator for the V_{DD} , OV_{DD} , and V_{CC} supplies and an optional 1.8V regulator for the V_{REF} reference. This onboard reference provides good accuracy (less than $\pm 5\text{mV}$) over temperature, contributing less than $\pm 0.1\text{dB}$ error to the ADC output. To evaluate the digital output, the QuickEval PC-based software can be used with the DC590B USB controller interface board. This board contains a generic USB to serial peripheral interface (SPI) controller. A 14-pin ribbon cable connects the evaluation board to the DC590B board. The DC590B allows the evaluation at approximately a 200Hz sample rate (f_{SMPL}). (See <http://cds.linear.com/docs/Reference%20Design/dc590B.pdf>). For higher sample rates the digital I/O pins can be accessed directly on the board. Contact LTC Applications for more information on higher sample rate evaluation.

RF Input Matching

The input resistance is about 205Ω . Input capacitance is 1.6pF . The impedance vs frequency of the RF input is detailed in the following table.

Table 1. RF Input Impedance

FREQUENCY (MHz)	INPUT IMPEDANCE (Ω)	S11	
		MAG	ANGLE ($^\circ$)
10	203.3-j1.4	0.605	-0.7
50	201.8-j7.0	0.605	-3.7
100	197.2-j13.7	0.606	-7.3
200	161.9-j25.8	0.608	-14.6
400	142.5-j43.6	0.614	-28.9
500	125.3-j48.5	0.619	-35.8
800	88.0-j60.4	0.636	-55.6
900	79.2-j62.6	0.643	-61.8
1000	71.8-j64.3	0.650	-67.7
1500	46.6-j68.8	0.685	-94.3
2000	31.1-j69.2	0.715	-116
2100	29.9-j69.0	0.721	-119.9
2500	22.4-j66.8	0.739	-134.1
3000	15.3-j60.7	0.756	-149.6
3500	9.9-j47.3	0.768	-163.2
4000	6.6-j16.9	0.779	-175.5
5000	9.8-j51.7	0.787	162.1
6000	18.5-j69.4	0.792	141.4

A shunt 68Ω resistor can be used to provide a broadband match at low frequencies up to 1GHz and from 4.5GHz to 6GHz. As shown in Figure 3, a nominal broadband input match can be achieved up to 1.8GHz by using an LC matching circuit consisting of a series 3.3nH inductor (L1) and a shunt 1.8pF capacitor (C1). This match will maintain a return loss of about 10dB across the band. For matching at higher frequencies, L1 and C1 values are listed in the table of Figure 1. The input reflection coefficient referenced to the RF input pin with no external components is shown on the smith chart in Figure 4. Alternatively, it is possible to match using an impedance transformation network by omitting R1 and transforming the 205Ω input to 50Ω . This narrow band matching will improve sensitivity up to about 6dB max, and the dynamic range remains the same. For example: by omitting R1 and setting $L1 = 1.8\text{nH}$ and $C1 = 3\text{pF}$, a 2:1 VSWR match can be obtained from 1.95GHz to 2.36GHz with a sensitivity improvement of 5dB.

APPLICATIONS INFORMATION

The RF input DC-blocking capacitor (C2) and C_{SQ} bias decoupling capacitor (C3), can be adjusted for low-frequency operation. For input frequencies down to 10MHz, 0.01 μ F is needed at C_{SQ} . For frequencies above 250MHz, the on-chip 20pF decoupling capacitor is sufficient and C_{SQ} may be eliminated as desired. The DC-blocking capacitor can be as large as 2200pF for 10MHz operation or 100pF for 2GHz operation. A DC-blocking capacitor larger than 2200pF results in an undesirable RF pulse response on the falling edge due to the rectifier action of the diode limiter/ESD protection at the RF pin. Therefore, the recommended value for C2 for general applications is conservatively set at 1000pF.

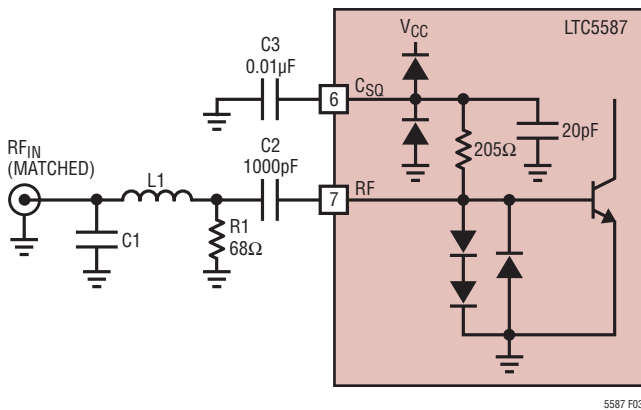

Figure 3. Simplified Schematic of the RF Input Interface

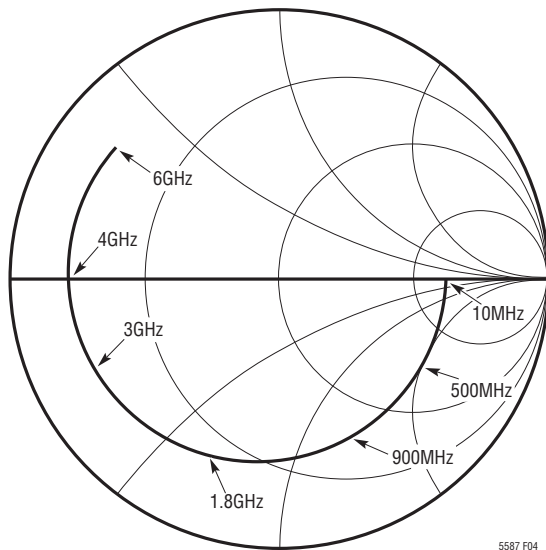

Figure 4. Input Reflection Coefficient

Filter Capacitor

The interface of the V_{OUT} pin of the LTC5587 is shown in Figure 5. It includes a push-pull output stage with a series 300 Ω resistor. The detector output stage is capable of sourcing and sinking 5mA of current. The V_{OUT} pin can be shorted to GND or V_{CC} (or V_{DD} whichever is lower) without damage, but going beyond the $V_{CC} + 0.5V$ or $V_{DD} + 0.5V$ and alternatively going beyond $GND - 0.5V$ may result in damage as the internal ESD protection diodes will start to conduct excessive current.

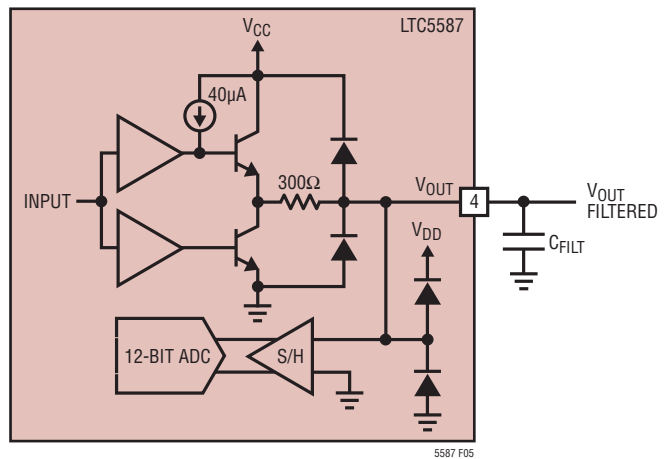

Figure 5. Simplified Schematic of the Detector Analog Output

The residual ripple due to RF modulation can be reduced by adding an external capacitor, C_{FILT} (C4 on evaluation circuit schematic) to the V_{OUT} pin to form a simple RC lowpass filter. The internal 300 Ω resistor in series with the output pin enables filtering of the output signal with just the addition of C_{FILT} . The filter $-3dB$ corner frequency, f_c , can be calculated with the following equation:

$$f_{C(-3dB)} = 1/(2 \cdot \pi \cdot 300 \cdot C_{FILT})$$

with f_c in Hz and C_{FILT} in F. Since the bandwidth of the detected signal is effectively limited by the internal 150kHz filter, a choice of $C_{FILT} = 1000pF$ sets the ADC $-3dB$ input bandwidth at 530kHz and does not affect the residual modulation ripple much. C_{FILT} has a small effect on ADC sampling accuracy. For example, when the sample rate of the ADC is changed from 25ksps to 500ksps, the output value changes less than 0.2dB with any choice of C_{FILT} .

APPLICATIONS INFORMATION

Figure 6 shows the effect of the external filter capacitor on the residual ripple level for a 4-carrier WCDMA downlink signal at 2.14GHz with -10dBm . Adding a $0.047\mu\text{F}$ capacitor to the output decreases the peak-to-peak output ripple from 150LSB to about 60LSB.

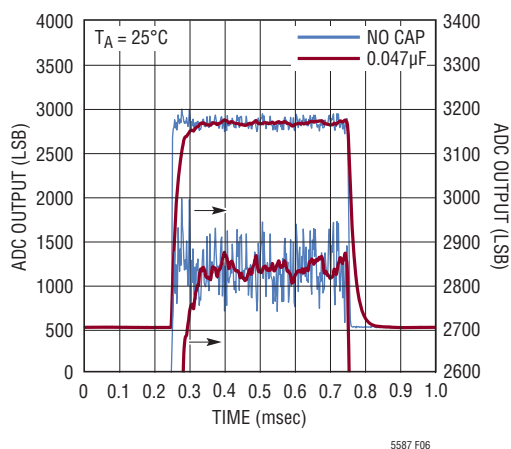

Figure 6. Residual Ripple, Output Transient Response for RF Pulse with WCDMA 4-Carrier Modulation

Figure 7 shows the transient response for a 2.6GHz WiMax signal with preamble and burst ripple reduced by a factor of three using a $0.047\mu\text{F}$ external filter capacitor. The average power in the preamble section is -10dBm , while the burst section has 3dB lower average power. With the capacitor, the ripple in the preamble section is about 0.5dB peak to peak. The modulation used was OFDM (WiMax 802.16-2004) MMDS band 1.5MHz BW, with 256 size FFT and 1 burst at QPSK $3/4$.

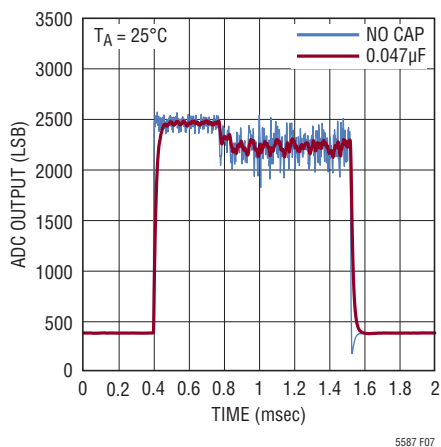

Figure 7. Residual Ripple for 2.6GHz WiMax OFDM 802.16-2004

Figure 8 shows how the peak-to-peak ripple decreases with increasing external filter capacitance value. Also shown is how the RF pulse response will have longer rise and fall times with the addition of this lowpass filter cap.

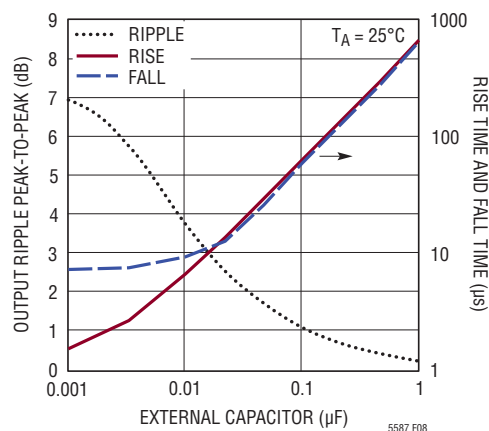

Figure 8. Residual Ripple, Output Transient Times for RF Pulse with WCDMA 4-Carrier Modulation vs External Filter Capacitor C4

Figure 9 shows the rise time and fall time is a strong function of the RF input power when the filter capacitor is not present.

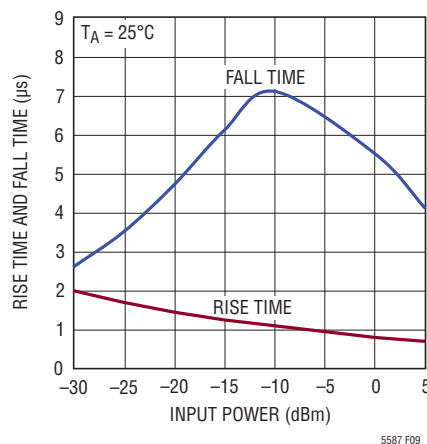

Figure 9. RF Pulse Response Rise Time and Fall Time vs RF Input Power

APPLICATIONS INFORMATION

For a given RF modulation type, WCDMA for example, the internal 150kHz filter provides nominal filtering of the residual ripple level. Additional external filtering happens in the log-domain, which introduces a systematic log-error in relation to the signal's crest factor as shown in the following equation in dB¹:

$$\text{Error}_{\text{dB}} = 10 \cdot \log_{10}(r + (1-r)10^{-\text{CF}/10}) - \text{CF} \cdot (r-1)$$

Where CF is the crest factor and r is the duty cycle of the measurement (or number of measurements made at the peak envelope divided by the total number of periodic measurements in the measurement period). It is important to note that the CF refers to the 150kHz low-pass filtered envelope of the signal. The error will depend on the statistics and bandwidth of the modulation signal in relation to the internal 150kHz filter. For example: simulations have shown for the case of WCDMA that it is possible to set the external filter capacitor corner frequency at 15kHz and only introduce an error less than 0.1dB.

Figure 10 shows the output AC modulation ripple as a function of modulation difference frequency for a 2-tone input signal at 2140MHz with -10dBm input power. The resulting deviation in the output voltage of the detector shows the effect of the internal 150kHz filter.

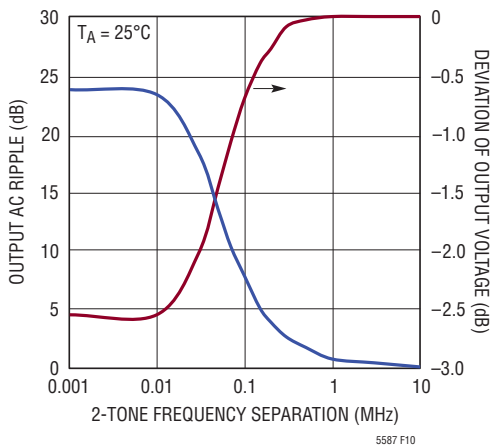

Figure 10. Output DC Voltage Deviation and Residual Ripple vs 2-Tone Separation Frequency

1. Steve Murray, "Beware of Spectrum Analyzer Power Averaging Techniques," Microwaves & RF, Dec. 2006.

The output voltage noise density and integrated noise are shown respectively in Figures 11 and 12 for various input power levels. The noise is a strong function of input level and there is roughly a 10dB improvement in the output noise level for an input level of 0dBm versus no input.

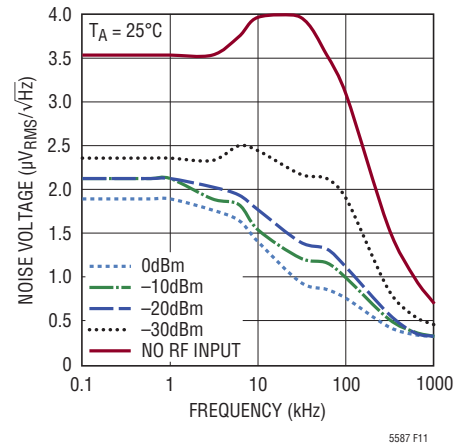

Figure 11. Output Voltage Noise Density

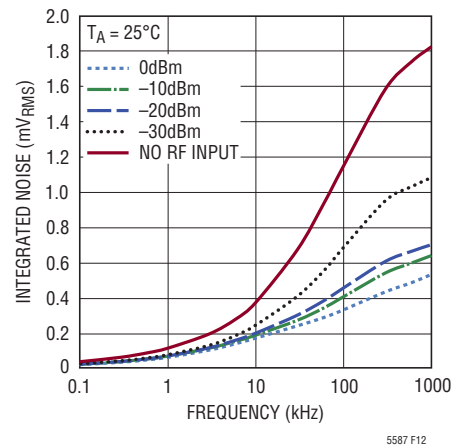

Figure 12. Integrated Output Voltage Noise

APPLICATIONS INFORMATION

The total noise at the ADC output is dominated by the output noise of the detector, and the sampling noise is insignificant. The peak-to-peak output noise is also almost independent of the sample rate. Figure 13 shows the peak-to-peak noise at the ADC output as a function of the RF input level for a CW RF input. Increasing C_{FILT} from 1000pF to 0.01 μ F gives roughly 2x to 3x lower noise over input power.

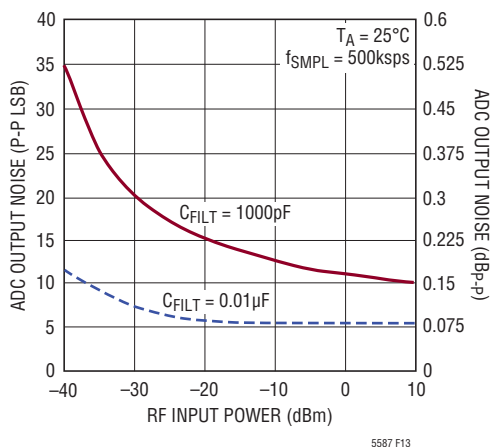

Figure 13. Peak-to-Peak Noise at ADC Output vs RF Input Power

Serial Interface

The LTC5587 communicates with microcontrollers, DSPs and other external circuitry via a 3-wire interface. Figure 14 shows the operating sequence of the serial interface.

Data Transfer

A rising CONV edge starts a conversion and disables SDO. After the conversion, the ADC automatically goes into sleep mode, drawing only leakage current. CONV going low enables SDO and clocks out the MSB bit, B11. SCK then synchronizes the data transfer with each bit being transmitted on the falling SCK edge and can be captured on the rising SCK edge. After completing the data transfer, if further SCK clocks are applied with CONV low, SDO will output zeros indefinitely (see Figure 14). For example, 16-clocks at SCK will produce the 12-bit data and four trailing zeros on SDO.

Sleep Mode

The LTC5587 ADC enters sleep mode to save power after each conversion if CONV remains high. In sleep mode, all bias currents are shut down and only leakage currents remain (about 0.1 μ A). The sample-and-hold is in hold mode while the ADC is in sleep mode. The ADC returns to sample mode after the falling edge of CONV during power-up.

Exiting Sleep Mode and Power-Up Time

By taking CONV low, the ADC powers up and acquires an input signal completely after the acquisition time (t_{ACQ}). After t_{ACQ} , the ADC is ready to perform a conversion again by a rising edge on CONV.

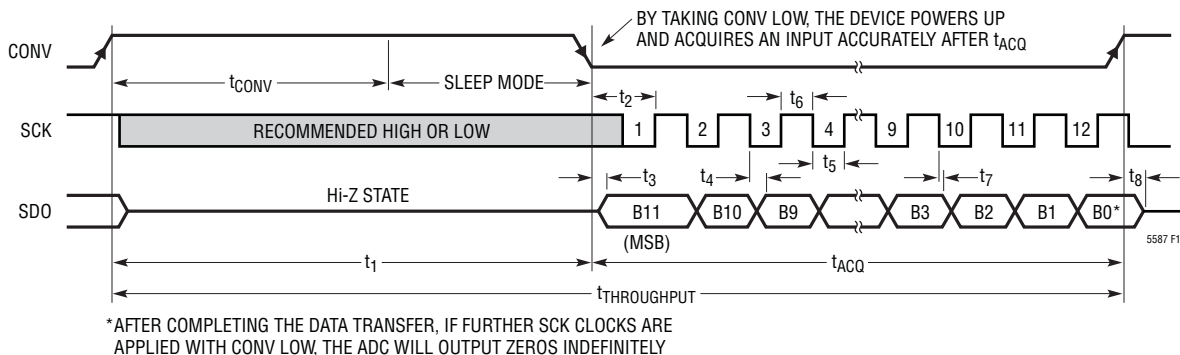

Figure 14. LTC5587 Serial Interface Timing Diagram

APPLICATIONS INFORMATION

Conversion Range

The V_{REF} pin defines the full-scale range of the ADC. The reference voltage can range from V_{DD} down to 1.4V. If the difference between the input voltage on the V_{OUT} pin and GND exceeds V_{REF} , the output code will stay fixed at all ones, and if this difference goes below 0V, the output code will stay fixed at all zeros. Figure 15 shows the ideal input/output characteristics for the ADC. The code transitions occur midway between successive integer LSB values (i.e., 0.5LSB, 1.5LSB, 2.5LSB, ..., $FS - 1.5LSB$). The output code is straight binary with $1LSB = V_{REF}/4096$. Using the onboard 1.8V reference on the evaluation board, the conversion range can be easily calculated between LSB and dBm. For an analog output slope of 32mV/dB, we can calculate the total 40dB range is equivalent to 2912.7LSB's at the ADC output:

$$40dB = (40dB \cdot 4096LSB \cdot 32mV/dB)/1.8V = 2912.7LSB$$

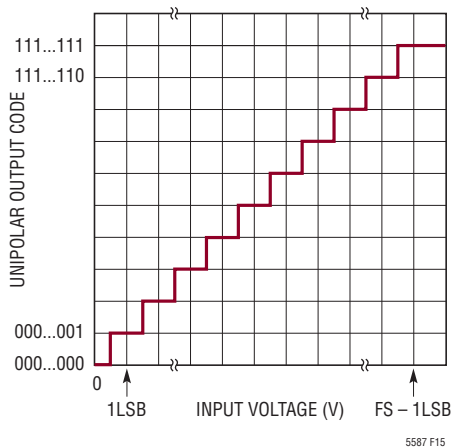

Figure 15. ADC Transfer Characteristics

Detector Enable Pin

A simplified schematic of the EN pin is shown in Figure 16. To enable the LTC5587 detector it is necessary to put greater than 2V on this pin. To disable or turn off the detector, this voltage should be below 0.3V. At an enable voltage of 3.3V the pin draws roughly 20 μ A. If the EN pin is not connected, the detector circuitry is disabled through an internal 500k pull-down resistor.

It is important that the voltage applied to the EN pin should never exceed V_{CC} by more than 0.5V. Otherwise, the supply current may be sourced through the upper ESD protection diode connected at the EN pin.

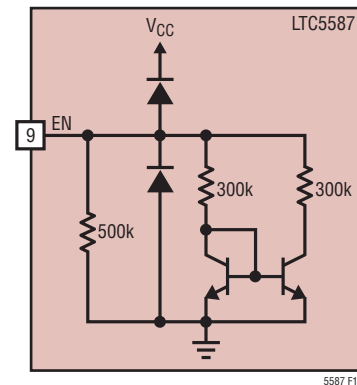
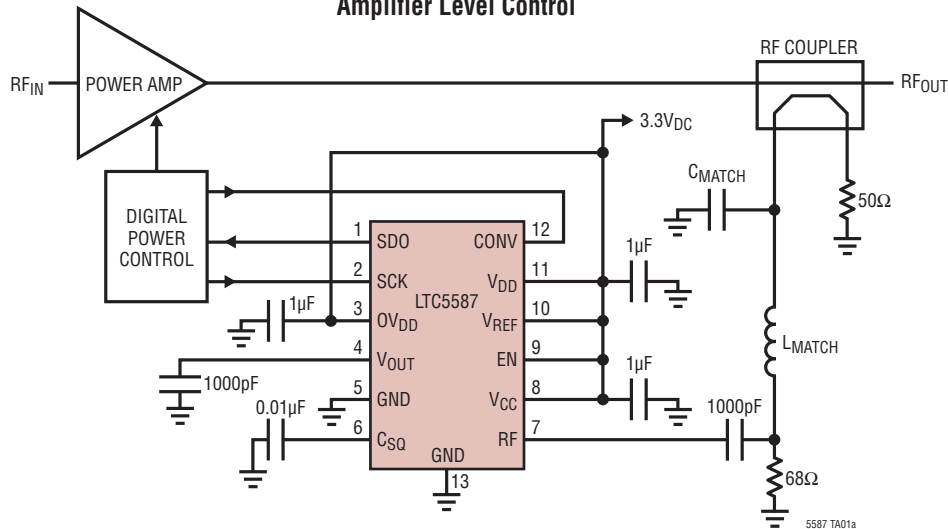

Figure 16. Enable Pin Simplified Schematic

TYPICAL APPLICATION

10MHz to 6GHz Infrastructure Power
Amplifier Level Control



RELATED PARTS

PART NUMBER	DESCRIPTION	COMMENTS
RF Power Detectors		
LTC5505	RF Power Detectors with >40dB Dynamic Range	300MHz to 3GHz, Temperature Compensated, 2.7V to 6V Supply
LTC5507	100kHz to 1000MHz RF Power Detector	100kHz to 1GHz, Temperature Compensated, 2.7V to 6V Supply
LTC5508	300MHz to 7GHz RF Power Detector	44dB Dynamic Range, Temperature Compensated, SC70 Package
LTC5509	300MHz to 3GHz RF Power Detector	36dB Dynamic Range, Low Power Consumption, SC70 Package
LTC5530	300MHz to 7GHz Precision RF Power Detector	Precision V _{OUT} Offset Control, Shutdown, Adjustable Gain
LTC5531	300MHz to 7GHz Precision RF Power Detector	Precision V _{OUT} Offset Control, Shutdown, Adjustable Offset
LTC5532	300MHz to 7GHz Precision RF Power Detector	Precision V _{OUT} Offset Control, Adjustable Gain and Offset
LT5534	50MHz to 3GHz Log RF Power Detector with 60dB Dynamic Range	±1dB Output Variation over Temperature, 38ns Response Time, Log Linear Response
LTC5536	Precision 600MHz to 7GHz RF Power Detector with Fast Comparator Output	25ns Response Time, Comparator Reference Input, Latch Enable Input, -26dBm to +12dBm Input Range
LT5537	Wide Dynamic Range Log RF/IF Detector	Low Frequency to 1GHz, 83dB Log Linear Dynamic Range
LT5538	75dB Dynamic Range 3.8GHz Log RF Power Detector	±0.8dB Accuracy Over Temperature
LTC5582	60dB Dynamic Range RMS Detector	40MHz to 10GHz, ±0.5dB Accuracy Over Temperature
LT5581	6GHz RMS Power Detector, 40dB Dynamic Range	±1dB Accuracy Over Temperature, Log Linear Response, 1.4mA at 3.3V
Infrastructure		
LT5568	700MHz to 1050MHz High Linearity Direct Quadrature Modulator	22.9dBm OIP3 at 850MHz, -160.3dBm/Hz Noise Floor, 50Ω, 0.5V _{DC} Baseband Interface, 3-Ch CDMA2000 ACPR = -71.4dBc at 850MHz
LT5572	1.5GHz to 2.5GHz High Linearity Direct Quadrature Modulator	21.6dBm OIP3 at 2GHz, -158.6dBm/Hz Noise Floor, High-Ohmic 0.5V _{DC} Baseband Interface, 4-Ch W-CDMA ACPR = -67.7dBc at 2.14GHz
LT5579	1.5GHz to 3.8GHz High Linearity Upconverting Mixer	27.3dBm OIP3 at 2.14GHz, 9.9dB NF, 2.6dB Conversion Gain, -35dBm LO Leakage
LTC5598	5MHz to 1600MHz High Linearity Direct Quadrature Modulator	27.7dBm OIP3 at 140MHz, -161.2dBm/Hz Noise Floor, 0.5V _{DC} Baseband Interface, -55dBm LO Leakage and 50.4dBc Image Rejection at 140MHz
LTC5588-1	200MHz to 6GHz Very High Linearity Direct Quadrature Modulator	30dBm OIP3 at 2.14GHz, Optimizable to 35dBm, -160.5dBm/Hz Output Noise Floor, 0.5V _{DC} Baseband Interface

Looking for pricing, stock, or lifecycle information?

Click below to explore more details on WIN SOURCE:

- ⊖ [View LTC5587IDD#TRPBF on WIN SOURCE](#)
- ⊖ [Analog Devices Inc. Information](#)

Optimize Your Supply Chain with WIN SOURCE Solutions

- ✓ Global Sourcing Solution
- ✓ Obsolete Management
- ✓ Cost Control Management
- ✓ Shortage Management
- ✓ Alternative Solution
- ✓ Excess Inventory Management