



THE DATASHEET OF DS14C88M



DS14C88 Quad CMOS Line Driver

Check for Samples: [DS14C88](#)

FEATURES

- Meets EIA-232D and CCITT V.28 Standards
- LOW Power Consumption
- Wide Power Supply Range: $\pm 5V$ to $\pm 12V$
- Available in SOIC Package

DESCRIPTION

The DS14C88, pin-for-pin compatible to the DS1488/MC1488, is a quad line drivers designed to interface data terminal equipment (DTE) with data circuit-terminating equipment (DCE). This device translates standard TTL/CMOS logic levels to levels conforming to EIA-232-D and CCITT V.28 standards.

The device is fabricated in low threshold CMOS metal gate technology. The device provides very low power consumption compared to its bipolar equivalents: 500 μA (DS14C88) versus 25 mA (DS1488).

The DS14C88 simplifies designs by eliminating the need for external slew rate control capacitors. Slew rate control in accordance with EIA-232D is provided on-chip, eliminating the output capacitors.

Connection Diagram

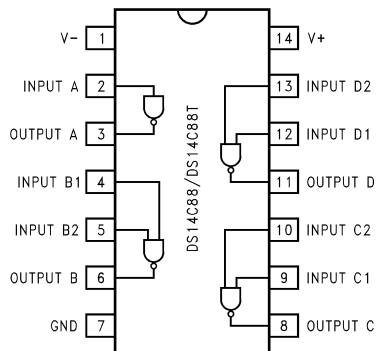

Figure 1. SOIC or PDIP Package- Top View
See Package Number NFF0014A or D0014A



These devices have limited built-in ESD protection. The leads should be shorted together or the device placed in conductive foam during storage or handling to prevent electrostatic damage to the MOS gates.



Please be aware that an important notice concerning availability, standard warranty, and use in critical applications of Texas Instruments semiconductor products and disclaimers thereto appears at the end of this data sheet.

All trademarks are the property of their respective owners.

Absolute Maximum Ratings⁽¹⁾⁽²⁾⁽³⁾⁽⁴⁾

Supply Voltage	
V ⁺ Pin	+13V
V ⁻ Pin	-13V
Driver Input Voltage	(V ⁺) +0.3V to GND -0.3V
Driver Output Voltage	V ⁺ - V _O ≤ 30V V ⁻ - V _O ≤ 30V
Continuous Power Dissipation @+25°C ⁽⁵⁾	
NFF0014A Package	1513 mW
D0014A Package	1063 mW
Junction Temperature	+150°C
Lead Temperature (Soldering 4 seconds)	+260°C
Storage Temperature Range	-65°C to +150°C

- (1) "Absolute Maximum Ratings" are those values beyond which the safety of the device cannot be ensured. They are not meant to imply that the devices should be operated at these limits. The tables of "Electrical Characteristics" specify conditions for device operation.
- (2) If Military/Aerospace specified devices are required, please contact the TI Sales Office/ Distributors for availability and specifications.
- (3) This Product does not meet 2000V ESD rating.
- (4) ESD Rating (HBM, 1.5 kΩ, 100 pF) ≥ 1.0 kV.
- (5) Derate NFF0014A Package 12.1 mW/°C, and D0014A Package 8.5 mW/°C above +25°C.

Recommended Operating Conditions

	Min	Max	Units
V ⁺ Supply (GND = 0V)	+4.5	+12.6	V
V ⁻ Supply (GND = 0V)	-4.5	-12.6	V
Operating Free Air Temp. (T _A) DS14C88	0	+75	°C

Electrical Characteristics

Over Recommended Operating Conditions, unless otherwise specified

Parameter		Test Conditions	Min	Typ	Max	Units	
I _{IL}	Maximum Low Input Current	V _{IN} = GND			+10	μA	
I _{IH}	Maximum High Input Current	V _{IN} = V ⁺	-10			μA	
V _{IL}	Low Level Input Voltage	V ⁺ ≥ +7V, V ⁻ ≤ -7V	GND		0.8	V	
		V ⁺ < +7V, V ⁻ > -7V	GND		0.6	V	
V _{IH}	High Level Input Voltage		2.0		V ⁺	V	
V _{OL}	Low Level Output Level	V _{IN} = V _{IH} R _L = 3 kΩ or 7 kΩ	V ⁺ = 4.5V, V ⁻ = -4.5V		-4.0	-3.0	V
			V ⁺ = 9V, V ⁻ = 9V		-8.0	-6.5	V
			V ⁺ = 12V, V ⁻ = -12V		-10.5	-9.0	V
V _{OH}	High Level Output Level	V _{IN} = V _{IL} R _L = 3 kΩ or 7 kΩ	V ⁺ = 4.5V, V ⁻ = -4.5V	3.0	4.0		V
			V ⁺ = 9V, V ⁻ = -9V	6.5	8.0		V
			V ⁺ = 12V, V ⁻ = -12V	9.0	10.5		V
I _{OS+}	High Level Output Short Circuit Current ⁽¹⁾	V _{IN} = 0.8V, V _O = GND	V ⁺ = +12V, V ⁻ = -12V	-45			mA
I _{OS-}	Low Level Output Short Circuit Current ⁽¹⁾						
R _{OUT}	Output Resistance	V ⁺ = V ⁻ = GND = 0V -2V ≤ V _O ≤ +2V ⁽²⁾ (Figure 2)	300				Ω

- (1) I_{OS+} and I_{OS-} values are for one output at a time. If more than one output is shorted simultaneously, the device dissipation may be exceeded.
- (2) Power supply (V⁺, V⁻) and GND pins are connected to ground for the Output Resistance Test (R_O).

Electrical Characteristics (continued)

Over Recommended Operating Conditions, unless otherwise specified

Parameter		Test Conditions	Min	Typ	Max	Units
I_{CC+}	Positive Supply Current	$V_{IN} = V_{ILmax}$ $R_L = OPEN$	$V^+ = 4.5V, V^- = -4.5V$		10	μA
			$V^+ = 9V, V^- = -9V$		30	μA
			$V^+ = 12V, V^- = -12V$		60	μA
		$V_{IN} = V_{IHmin}$ $R_L = OPEN$	$V^+ = 4.5V, V^- = -4.5V$		50	μA
			$V^+ = 9V, V^- = -9V$		300	μA
			$V^+ = 12V, V^- = -12V$		500	μA
I_{CC-}	Negative Supply Current	$V_{IN} = V_{ILmax}$ $R_L = OPEN$	$V^+ = 4.5V, V^- = -4.5V$		-10	μA
			$V^+ = 9V, V^- = -9V$		-10	μA
			$V^+ = 12V, V^- = -12V$		-10	μA
		$V_{IN} = V_{IHmin}$ $R_L = OPEN$	$V^+ = 4.5V, V^- = -4.5V$		-30	μA
			$V^+ = 9V, V^- = -9V$		-30	μA
			$V^+ = 12V, V^- = -12V$		-60	μA

Switching Characteristics⁽¹⁾⁽²⁾

Over Recommended Operating Conditions, unless otherwise specified (Figure 3, Figure 4)

Parameter		Test Conditions	Min	Typ	Max	Units
t_{PLH}	Propagation Delay Low to High	$V^+ = +4.5V, V^- = -4.5V$		1.5	6.0	μs
		$V^+ = +9.0V, V^- = -9.0V$		1.2	5.0	μs
		$V^+ = +12V, V^- = -12V$		1.2	4.0	μs
t_{PHL}	Propagation Delay High to Low	$V^+ = +4.5V, V^- = -4.5V$		1.5	6.0	μs
		$V^+ = +9.0V, V^- = -9.0V$		1.35	5.0	μs
		$V^+ = +12V, V^- = -12V$		1.3	4.0	μs
t_r	Rise Time ⁽³⁾		0.2	1.0	μs	
t_f	Fall Time ⁽³⁾		0.2	1.0	μs	
tsk	Typical Propagation Delay Skew	$V^+ = +4.5V, V^- = -4.5V$		250		ns
		$V^+ = +9.0V, V^- = -9.0V$		200		ns
		$V^+ = +12V, V^- = -12V$		150		ns
S_R	Output Slew Rate ⁽³⁾	$R_L = 3\text{ k}\Omega$ to $7\text{ k}\Omega$ $C_L = 15\text{ pF}$ to 2500 pF			30	$V/\mu s$

 (1) AC input test waveforms for test purposes: $t_r = t_f \leq 20\text{ ns}$, $V_{IH} = 2V$, $V_{IL} = 0.8V$ (0.6V at $V^+ = 4.5V, V^- = -4.5V$)

 (2) Input rise and fall times must not exceed 5 μs .

(3) The output slew rate, rise time, and fall time are measured from the +3.0V to the -3.0V level on the output waveform.

Parameter Measure Information

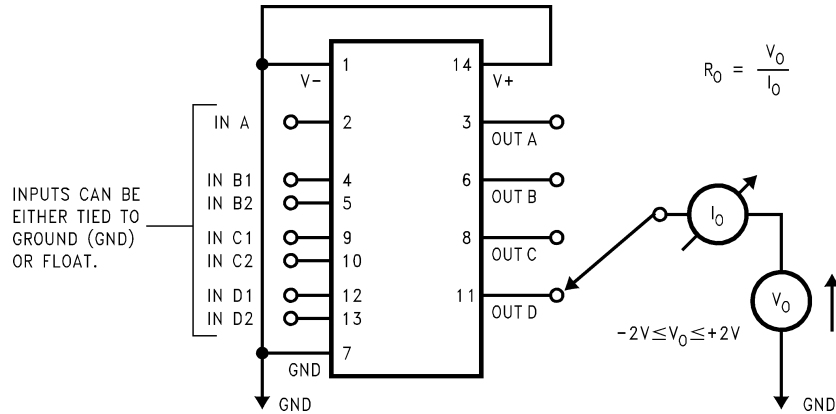

Figure 2. Output Resistance Test Circuit (Power-Off)

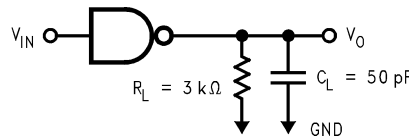

Figure 3. Driver Load Circuit(4)

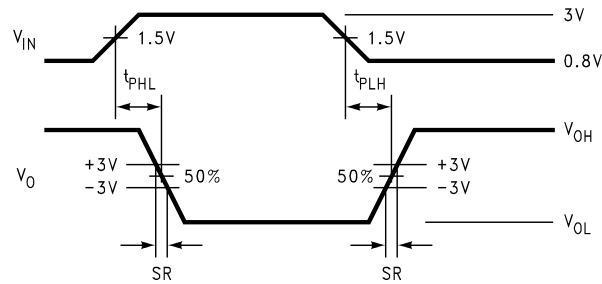

Figure 4. Driver Switching Waveform

(4) CL include jig and probe capacitances.

TYPICAL APPLICATION INFORMATION

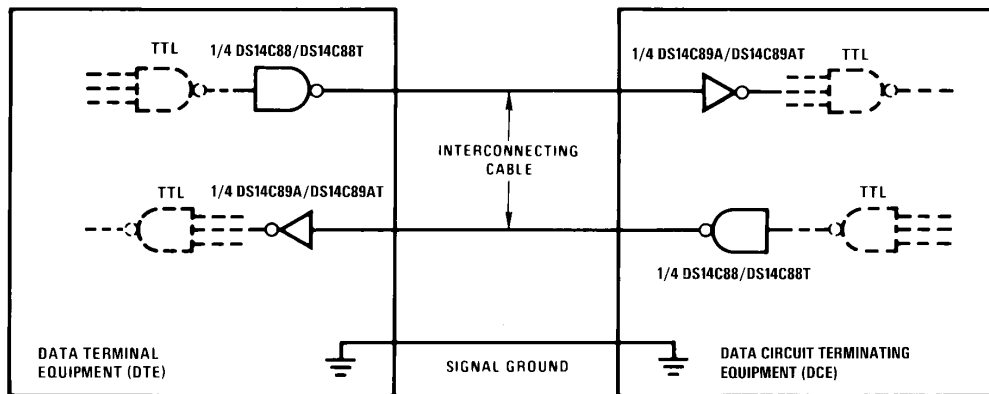

Figure 5. EIA-232D Data Transmission

REVISION HISTORY

Changes from Revision B (April 2013) to Revision C	Page
• Changed layout of National Data Sheet to TI format	4

PACKAGING INFORMATION

Orderable Device	Status (1)	Package Type	Package Drawing	Pins	Package Qty	Eco Plan (2)	Lead/Ball Finish (6)	MSL Peak Temp (3)	Op Temp (°C)	Device Marking (4/5)	Samples
DS14C88M/NOPB	ACTIVE	SOIC	D	14	55	Green (RoHS & no Sb/Br)	CU SN	Level-1-260C-UNLIM	0 to 70	DS14C88M	Samples
DS14C88MX/NOPB	ACTIVE	SOIC	D	14	2500	Green (RoHS & no Sb/Br)	CU SN	Level-1-260C-UNLIM	0 to 70	DS14C88M	Samples

(1) The marketing status values are defined as follows:

ACTIVE: Product device recommended for new designs.

LIFEBUY: TI has announced that the device will be discontinued, and a lifetime-buy period is in effect.

NRND: Not recommended for new designs. Device is in production to support existing customers, but TI does not recommend using this part in a new design.

PREVIEW: Device has been announced but is not in production. Samples may or may not be available.

OBsolete: TI has discontinued the production of the device.

(2) **RoHS:** TI defines "RoHS" to mean semiconductor products that are compliant with the current EU RoHS requirements for all 10 RoHS substances, including the requirement that RoHS substance do not exceed 0.1% by weight in homogeneous materials. Where designed to be soldered at high temperatures, "RoHS" products are suitable for use in specified lead-free processes. TI may reference these types of products as "Pb-Free".

RoHS Exempt: TI defines "RoHS Exempt" to mean products that contain lead but are compliant with EU RoHS pursuant to a specific EU RoHS exemption.

Green: TI defines "Green" to mean the content of Chlorine (Cl) and Bromine (Br) based flame retardants meet JS709B low halogen requirements of <=1000ppm threshold. Antimony trioxide based flame retardants must also meet the <=1000ppm threshold requirement.

(3) MSL, Peak Temp. - The Moisture Sensitivity Level rating according to the JEDEC industry standard classifications, and peak solder temperature.

(4) There may be additional marking, which relates to the logo, the lot trace code information, or the environmental category on the device.

(5) Multiple Device Markings will be inside parentheses. Only one Device Marking contained in parentheses and separated by a "~" will appear on a device. If a line is indented then it is a continuation of the previous line and the two combined represent the entire Device Marking for that device.

(6) Lead/Ball Finish - Orderable Devices may have multiple material finish options. Finish options are separated by a vertical ruled line. Lead/Ball Finish values may wrap to two lines if the finish value exceeds the maximum column width.

Important Information and Disclaimer:The information provided on this page represents TI's knowledge and belief as of the date that it is provided. TI bases its knowledge and belief on information provided by third parties, and makes no representation or warranty as to the accuracy of such information. Efforts are underway to better integrate information from third parties. TI has taken and continues to take reasonable steps to provide representative and accurate information but may not have conducted destructive testing or chemical analysis on incoming materials and chemicals. TI and TI suppliers consider certain information to be proprietary, and thus CAS numbers and other limited information may not be available for release.

In no event shall TI's liability arising out of such information exceed the total purchase price of the TI part(s) at issue in this document sold by TI to Customer on an annual basis.

TAPE AND REEL INFORMATION



QUADRANT ASSIGNMENTS FOR PIN 1 ORIENTATION IN TAPE



*All dimensions are nominal

Device	Package Type	Package Drawing	Pins	SPQ	Reel Diameter (mm)	Reel Width W1 (mm)	A0 (mm)	B0 (mm)	K0 (mm)	P1 (mm)	W (mm)	Pin1 Quadrant
DS14C88MX/NOPB	SOIC	D	14	2500	330.0	16.4	6.5	9.35	2.3	8.0	16.0	Q1

TAPE AND REEL BOX DIMENSIONS



*All dimensions are nominal



Device	Package Type	Package Drawing	Pins	SPQ	Length (mm)	Width (mm)	Height (mm)
DS14C88MX/NOPB	SOIC	D	14	2500	367.0	367.0	35.0

D (R-PDSO-G14)

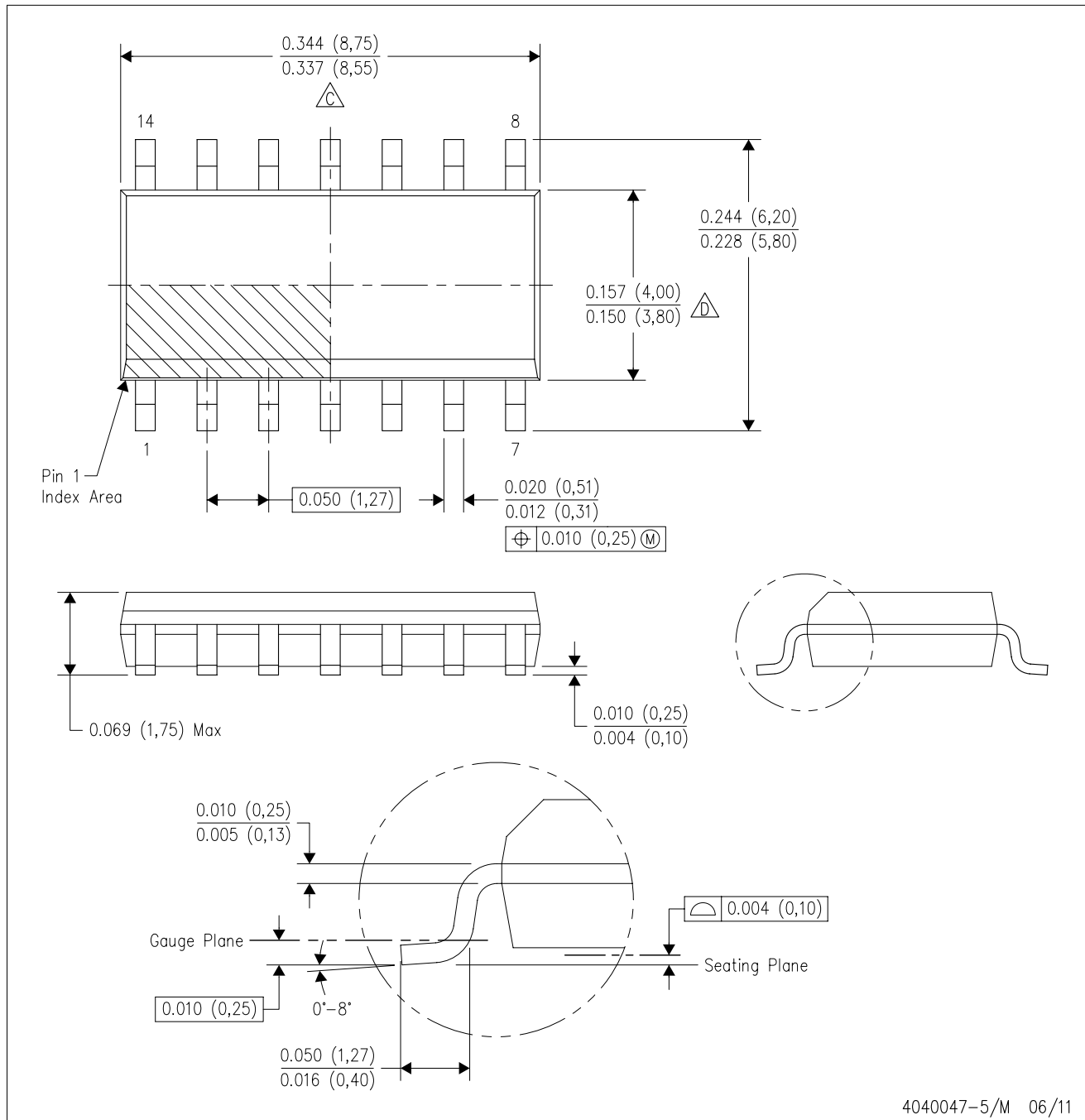
PLASTIC SMALL OUTLINE



4040047-5/M 06/11

- NOTES:
- A. All linear dimensions are in inches (millimeters).
 - B. This drawing is subject to change without notice.
 -  Body length does not include mold flash, protrusions, or gate burrs. Mold flash, protrusions, or gate burrs shall not exceed 0.006 (0,15) each side.
 -  Body width does not include interlead flash. Interlead flash shall not exceed 0.017 (0,43) each side.
 - E. Reference JEDEC MS-012 variation AB.

D (R-PDSO-G14)

PLASTIC SMALL OUTLINE



4211283-3/E 08/12

- NOTES:
- All linear dimensions are in millimeters.
 - This drawing is subject to change without notice.
 - Publication IPC-7351 is recommended for alternate designs.
 - Laser cutting apertures with trapezoidal walls and also rounding corners will offer better paste release. Customers should contact their board assembly site for stencil design recommendations. Refer to IPC-7525 for other stencil recommendations.
 - Customers should contact their board fabrication site for solder mask tolerances between and around signal pads.

IMPORTANT NOTICE AND DISCLAIMER

TI PROVIDES TECHNICAL AND RELIABILITY DATA (INCLUDING DATASHEETS), DESIGN RESOURCES (INCLUDING REFERENCE DESIGNS), APPLICATION OR OTHER DESIGN ADVICE, WEB TOOLS, SAFETY INFORMATION, AND OTHER RESOURCES "AS IS" AND WITH ALL FAULTS, AND DISCLAIMS ALL WARRANTIES, EXPRESS AND IMPLIED, INCLUDING WITHOUT LIMITATION ANY IMPLIED WARRANTIES OF MERCHANTABILITY, FITNESS FOR A PARTICULAR PURPOSE OR NON-INFRINGEMENT OF THIRD PARTY INTELLECTUAL PROPERTY RIGHTS.

These resources are intended for skilled developers designing with TI products. You are solely responsible for (1) selecting the appropriate TI products for your application, (2) designing, validating and testing your application, and (3) ensuring your application meets applicable standards, and any other safety, security, or other requirements. These resources are subject to change without notice. TI grants you permission to use these resources only for development of an application that uses the TI products described in the resource. Other reproduction and display of these resources is prohibited. No license is granted to any other TI intellectual property right or to any third party intellectual property right. TI disclaims responsibility for, and you will fully indemnify TI and its representatives against, any claims, damages, costs, losses, and liabilities arising out of your use of these resources.

TI's products are provided subject to TI's Terms of Sale (www.ti.com/legal/termsofsale.html) or other applicable terms available either on ti.com or provided in conjunction with such TI products. TI's provision of these resources does not expand or otherwise alter TI's applicable warranties or warranty disclaimers for TI products.

Mailing Address: Texas Instruments, Post Office Box 655303, Dallas, Texas 75265
Copyright © 2019, Texas Instruments Incorporated

Looking for pricing, stock, or lifecycle information?

Click below to explore more details on WIN SOURCE:

 [View DS14C88M](#) on WIN SOURCE

 [Texas Instruments](#) Information

Optimize Your Supply Chain with WIN SOURCE Solutions

-  Global Sourcing Solution
-  Obsolete Management
-  Cost Control Management
-  Shortage Management
-  Alternative Solution
-  Excess Inventory Management