



THE DATASHEET OF MICS-5914





The MiCS-5914 is a compact MOS sensor.

The MiCS-5914 is a robust MEMS sensor for ammonia detection; suitable also for gas leak detection and indoor and outdoor air quality monitoring.

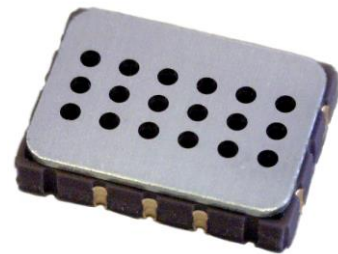

Features

- Smallest footprint for compact designs (5 x 7 x 1.55 mm)
- Robust MEMS sensor for harsh environments
- High-volume manufacturing for low-cost applications
- Short lead-times

Detectable gases

- | | | |
|--------------|---------------------------------|-------------|
| • Ammonia | NH_3 | 1 – 500ppm |
| • Ethanol | $\text{C}_2\text{H}_5\text{OH}$ | 10 – 500ppm |
| • Hydrogen | H_2 | 1 – 1000ppm |
| • Propane | C_3H_8 | >1000ppm |
| • Iso-butane | C_4H_{10} | >1000ppm |

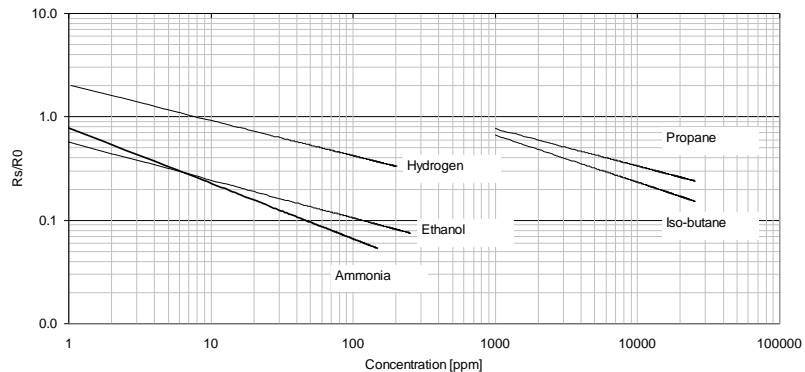

Continuous power ON, 25°C, 50% RH

For more information please contact:

info.em@sgxsensortech.com

SGX Sensortech, Courtils 1
CH-2035 Corcelles-Cormondrèche
Switzerland

www.sgxsensortech.com

Performance sensor

| Characteristic RED sensor | Symbol | Typ | Min | Max | Unit |
|---|--------|-----|-----|------|-----------|
| Sensing resistance in air (see note 1) | R_0 | - | 10 | 1500 | $k\Omega$ |
| Typical NH ₃ detection range | FS | | 1 | 300 | ppm |
| Sensitivity factor (see note 2) | S_R | - | 1.5 | 15 | - |

Notes:

1. Sensing resistance in air R_0 is measured under controlled ambient conditions, i.e. synthetic air at 23 \pm 5°C and 50 \pm 10% RH. Sampling test.
2. Sensitivity factor is defined as R_s in air divided by R_s at 1 ppm of NH₃. Test conditions are 23 \pm 5°C and 50 \pm 10% RH. Indicative values only. Sampling test.

IMPORTANT PRECAUTIONS:

Read the following instructions carefully before using the MiCS-5914 described here to avoid erroneous readings and to prevent the device from permanent damage.

- The sensor must be reflow soldered in a neutral atmosphere, without soldering flux vapours.
- The sensor must not be exposed to high concentrations of organic solvents, silicone vapours or cigarette-smoke in order to avoid poisoning the sensitive layer.
- Heater voltage above the specified maximum rating will destroy the sensor due to overheating.
- This sensor is to be placed in a filtered package that protects it against water and dust projections.
- SGX sensortech strongly recommends using ESD protection equipment to handle the sensor.

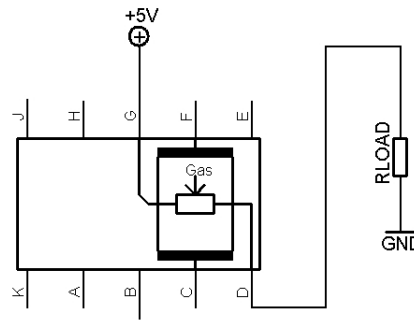
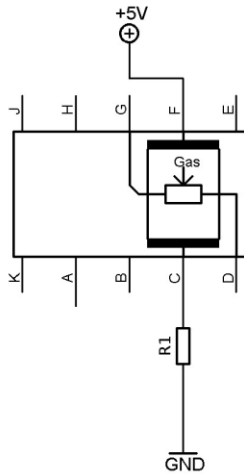

MiCS-5914 with recommended supply circuit (top view)

R1 is typically a E96 resistor at 93.1 Ω. This resistor is necessary to obtain the right temperature on the heater while using a single 5V power supply. The resulting voltage is typically $V_H = 2.2V$.

MiCS-5914 with measurement circuit (top view)

The voltage measured on the load resistor is directly linked to the resistance of the sensor respectively. RLOAD must be 820 Ω at the lowest in order not to damage the sensitive layer.

| Parameter | Symbol | Typ | Min | Max | Unit |
|-------------------------------------|--------|-----|-----|-----|------|
| Heating power | P_H | 66 | 60 | 73 | mW |
| Heating voltage | V_H | 2.2 | - | - | V |
| Heating current | I_H | 30 | - | - | mA |
| Heating resistance at nominal power | R_H | 72 | 64 | 80 | Ω |

| Rating | Symbol | Value / Range | Unit |
|---|--------------|---------------|------|
| Maximum heater power dissipation | P_H | 88 | mW |
| Maximum sensitive layer power dissipation | P_s | 8 | mW |
| Voltage supplyHeating current | V_{supply} | 4.9 – 5.1 | V |
| Relative humidity range | RH | 5 – 95 | %RH |
| Ambient operating temperature | T_{amb} | -30 – 85 | °C |
| Storage temperature range | T_{sto} | -40 – 120 | °C |
| Storage humidity range | RHsto | 5 - 95 | %RH |

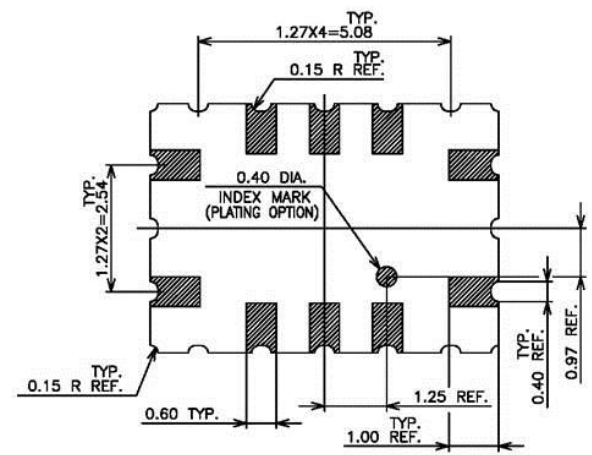
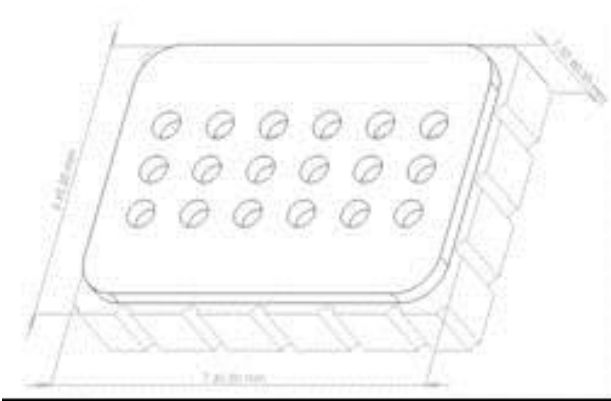

Package outline dimensions

The package is compatible with SMD assembly process.

| Pin | Connection |
|-----|------------|
| A | |
| B | |
| C | Rh1 |
| D | Rs1 |
| E | |
| F | Rh2 |
| G | Rs2 |
| H | |
| J | |
| K | |

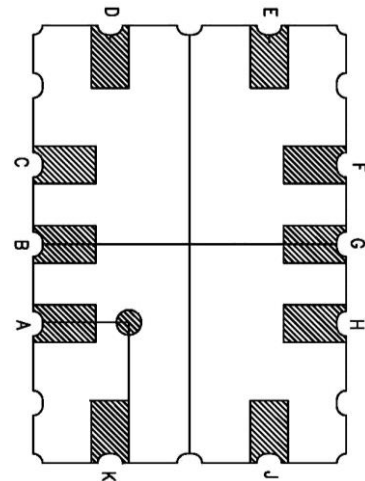

MiCS-5914 configuration (bottom view)

Sensor configuration

The silicon gas sensor structure consists of an accurately micro machined diaphragm with an embedded heating resistor and the sensing layer on top. The internal connections are shown above.

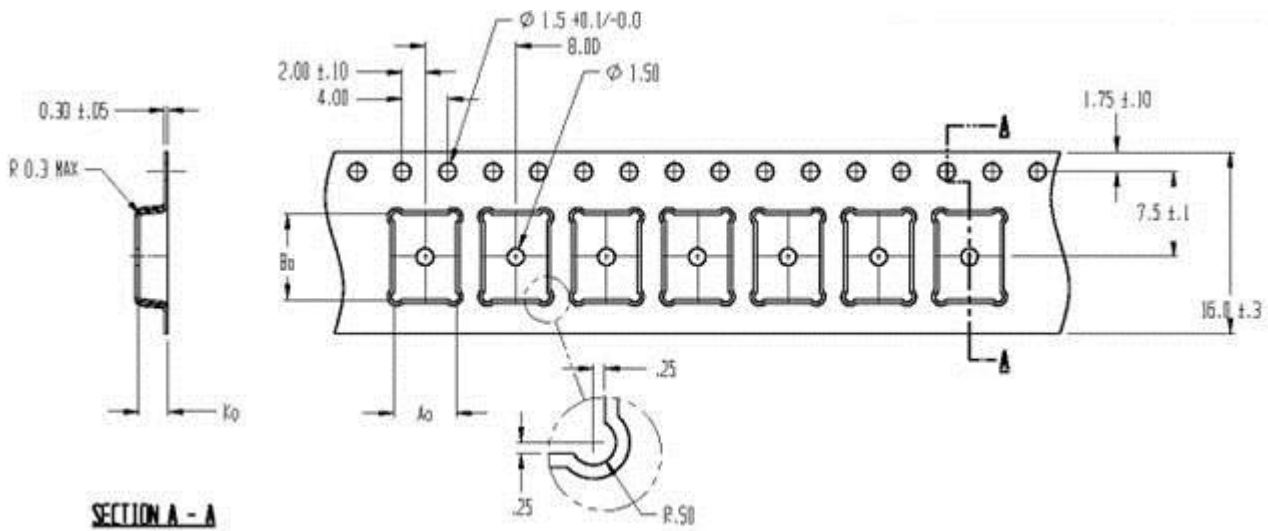

Packaging

The sensors are packaged in a tape and reel for expedition.

The sensors are placed in a carrier type. The dimensions of the cavity are 5.5 x 7.5 x 2.55 mm (the tolerance is +/- 0.2 mm).

The outside dimension of the reel is either 178 +/- mm (for a maximum of 700 sensors) or 330 + 0.25 / -4 mm (for a maximum of 2000 sensors).

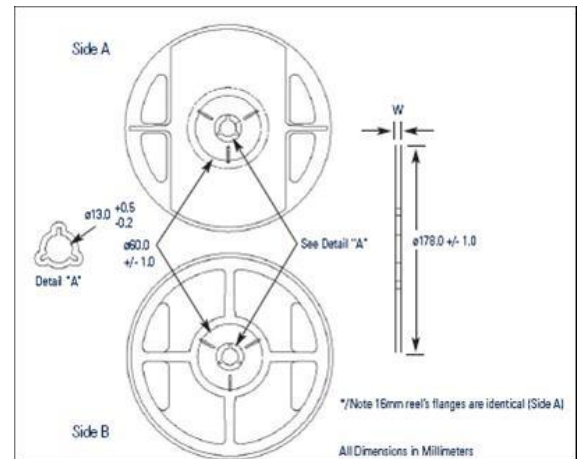

For more information please contact:

info.em@sgxsensortech.com



SGX Sensortech, Courtils 1
CH-2035 Corcelles-Cormondrèche
Switzerland

www.sgxsensortech.com







Whilst SGX sensortech has taken care to ensure the accuracy of the information contained herein it accepts no responsibility for the consequences of any use thereof and also reserves the right to change the specification of goods without notice. SGX sensortech accepts no liability beyond the set out in its standard conditions of sale in respect of infringement of third party patents arising from the use of tubes or other devices in accordance with information contained herein.

Looking for pricing, stock, or lifecycle information?

Click below to explore more details on WIN SOURCE:

-  [View MICS-5914 on WIN SOURCE](#)
-  [Amphenol Information](#)

Optimize Your Supply Chain with WIN SOURCE Solutions

-  Global Sourcing Solution
-  Obsolete Management
-  Cost Control Management
-  Shortage Management
-  Alternative Solution
-  Excess Inventory Management