



**THE DATASHEET OF
DS14C232TMX/NOPB**



DS14C232 Low Power +5V Powered TIA/EIA-232 Dual Driver/Receiver

Check for Samples: [DS14C232](#)

FEATURES

- Pin Compatible with Industry Standard MAX232, LT1081, ICL232 and TSC232
- Single +5V Power Supply
- Low Power— I_{CC} 3.0 mA Maximum
- DS14C232C Meets TIA/EIA-232-E (RS-232) and CCITT V.28 Standards
- CMOS Technology
- Receiver Noise Filter
- Package Efficiency—2 Drivers and 2 Receivers
- Available in Plastic DIP, Narrow and Wide SOIC Packages
- TIA/EIA-232 Compatible Extended Temperature Range Option:
 - DS14C232T –40°C to +85°C
 - DS14C232E/J: –55°C to +125°C

DESCRIPTION

The DS14C232 is a low power dual driver/receiver featuring an onboard DC to DC converter, eliminating the need for $\pm 12V$ power supplies. The device only requires a +5V power supply. I_{CC} is specified at 3.0 mA maximum, making the device ideal for battery and power conscious applications. The drivers' slew rate is set internally and the receivers feature internal noise filtering, eliminating the need for external slew rate and filter capacitors. The device is designed to interface data terminal equipment (DTE) with data circuit-terminating equipment (DCE). The driver inputs and receiver outputs are TTL and CMOS compatible. DS14C232C driver outputs and receiver inputs meet TIA/EIA-232-E (RS-232) and CCITT V.28 standards.

Connection Diagram

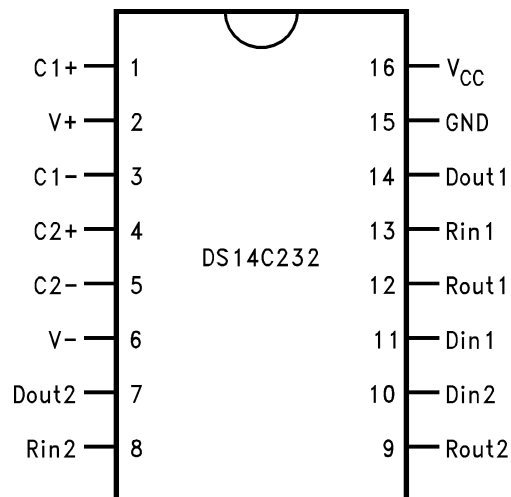

**Figure 1. 16-Pin PDIP (See NFG Package)- Top View
16-Pin SOIC (See D Package)**



Please be aware that an important notice concerning availability, standard warranty, and use in critical applications of Texas Instruments semiconductor products and disclaimers thereto appears at the end of this data sheet.

All trademarks are the property of their respective owners.

Functional Diagram

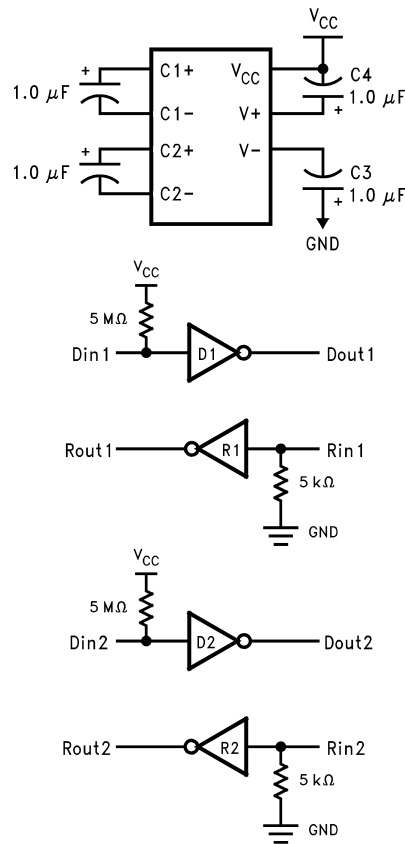

Figure 2. Functional Block Diagram



These devices have limited built-in ESD protection. The leads should be shorted together or the device placed in conductive foam during storage or handling to prevent electrostatic damage to the MOS gates.

Absolute Maximum Ratings⁽¹⁾⁽²⁾

Supply Voltage, V_{CC}	-0.3V to 6V
V^+ Pin	$(V_{CC} - 0.3)V$ to +14V
V^- Pin	+0.3V to -14V
Driver Input Voltage	-0.3V to $(V_{CC} + 0.3V)$
Driver Output Voltage	$(V^+ + 0.3V)$ to $(V^- - 0.3V)$
Receiver Input Voltage	$\pm 25V$
Receiver Output Voltage	-0.3V to $(V_{CC} + 0.3V)$
Junction Temperature	+150°C
Maximum Package Power Dissipation @ 25°C ⁽³⁾	
NFG Package	1698 mW
D Package	1156 mW
Short Circuit Duration, D_{OUT}	Continuous
Storage Temp. Range	-65°C to +150°C
Lead Temp. (Soldering, 4 sec.)	+260°C
ESD Rating	
(HBM, 1.5 k Ω , 100 pF)	≥ 2.5 kV

- (1) "Absolute Maximum Ratings" are those values beyond which the safety of the device cannot be verified. They are not meant to imply that the devices should be operated at these limits. The tables of "Electrical Characteristics" specify conditions for device operation.
- (2) Specifications for the 883 version of this product are listed separately on the following pages.
- (3) Ratings apply to ambient temperature at +25°C. Above this temperature derate: NFG Package 15.6 mW/°C, and D Package 10.6 mW/°C.

Recommended Operating Conditions

	Min	Max	Units
Supply Voltage, V_{CC}	4.5	5.5	V
Operating Free Air Temp. (T_A)			
DS14C232C	0	+70	°C
DS14C232T	-40	+85	°C

Electrical Characteristics⁽¹⁾

Over recommended operating conditions, unless otherwise specified

Symbol	Parameter	Conditions	Min	Typ ⁽²⁾	Max	Units
DC TO DC CONVERTER CHARACTERISTICS						
V^+	Positive Power Supply	$R_L = 3$ k Ω , C_1 - $C_4 = 1.0$ μ F, $D_{IN} = 0.8V$		9.0		V
V^-	Negative Power Supply	$R_L = 3$ k Ω , C_1 - $C_4 = 1.0$ μ F, $D_{IN} = 2.0V$		-8.5		V
I_{CC}	Supply (V_{CC}) Current	No Load		1.0	3.0	mA
DRIVER CHARACTERISTICS						
V_{IH}	High Level Input Voltage		2		V_{CC}	V
V_{IL}	Low Level Input Voltage		GND		0.8	V
I_{IH}	High Level Input Current	$V_{IN} \geq 2.0V$	-10		+10	μ A
I_{IL}	Low Level Input Current	$V_{IN} \leq 0.8V$	-10		+10	μ A
V_{OH}	High Level Output Voltage	$R_L = 3$ k Ω	5.0	8.0		V
V_{OL}	Low Level Output Voltage	$R_L = 3$ k Ω		-7.0	-5.0	V

- (1) Current into device pins is defined as positive. Current out of device pins is defined as negative. All voltages are referenced to ground unless otherwise specified.
- (2) All typicals are given for $V_{CC} = 5.0V$.

Electrical Characteristics⁽¹⁾ (continued)

Over recommended operating conditions, unless otherwise specified

Symbol	Parameter	Conditions	Min	Typ ⁽²⁾	Max	Units	
I _{OS+}	Output High Short Circuit Current	V _O = 0V, V _{IN} = 0.8V	See ⁽³⁾	-30	-15	-5.0	mA
I _{OS-}	Output Low Short Circuit Current	V _O = 0V, V _{IN} = 2V		5.0	11	30	mA
R _O	Output Resistance	-2V ≤ V _O ≤ +2V, V _{CC} = 0V = GND	300			Ω	
RECEIVER CHARACTERISTICS							
V _{TH}	Input High Threshold Voltage	V _{CC} = 5.0V		1.9	2.4	V	
		V _{CC} = 5.0V ±10%		1.9	2.6	V	
V _{TL}	Input Low Threshold Voltage		0.8	1.5		V	
V _{HY}	Hysteresis		0.2	0.4	1.0	V	
R _{IN}	Input Resistance	-15V ≤ V _{IN} ≤ +15V	3.0	4.7	7.0	kΩ	
I _{IN}	Input Current	V _{IN} = +15V	+2.14	+3.75	+5.0	mA	
		V _{IN} = +3V	+0.43	+0.64	+1.0	mA	
		V _{IN} = -3V	-1.0	-0.64	-0.43	mA	
		V _{IN} = -15V	-5.0	-3.75	-2.14	mA	
V _{OH}	High Level Output Voltage	V _{IN} = -3V, I _O = -3.2 mA	3.5	4.5		V	
		V _{IN} = -3V, I _O = -20 μA	4.0	4.9		V	
V _{OL}	Low Level Output Voltage	V _{IN} = +3V, I _O = +3.2 mA		0.15	0.4	V	

(3) I_{OS+} and I_{OS-} values are for one output at a time. If more than one output is shorted simultaneously, the device power dissipation may be exceeded.

Switching Characteristics

Over recommended operating conditions, unless otherwise specified.

Symbol	Parameter	Conditions	Min	Typ	Max	Units	
DRIVER CHARACTERISTICS							
t _{PLH}	Propagation Delay Low to High	R _L = 3 kΩ C _L = 50 pF	(Figure 5, Figure 6)		1.0	4.0	μs
t _{PHL}	Propagation Delay High to Low			1.0	4.0	μs	
t _{SK}	Skew t _{PLH} - t _{PHL}			0.1	1.0	μs	
SR1	Output Slew Rate	R _L = 3 kΩ to 7 kΩ, C _L = 50 pF	See ⁽¹⁾		4.0	30	V/μs
SR2	Output Slew Rate	R _L = 3 kΩ, C _L = 2500 pF		4.5		V/μs	
RECEIVER CHARACTERISTICS							
t _{PLH}	Propagation Delay Low to High	Input Pulse Width > 10 μs		2.9	6.5	μs	
t _{PHL}	Propagation Delay High to Low	C _L = 50 pF		2.5	6.5	μs	
t _{SK}	Skew t _{PLH} - t _{PHL}	(Figure 7, Figure 8)		0.4	2.0	μs	
t _{nw}	Noise Pulse Width Rejected	(Figure 7, Figure 8)		0.7	0.5	μs	

(1) Slew rate is defined as ΔV/Δt, measured between ±3V level.

Absolute Maximum Ratings⁽¹⁾⁽²⁾

Supply Voltage, V_{CC}	-0.3V to 6V
V^+ Pin	$(V_{CC} - 0.3)V$ to +14V
V^- Pin	+0.3V to -14V
Driver Input Voltage	-0.3V to $(V_{CC} + 0.3V)$
Driver Output Voltage	$(V^+ + 0.3V)$ to $(V^- - 0.3V)$
Receiver Input Voltage	$\pm 25V$
Receiver Output Voltage	-0.3V to $(V_{CC} + 0.3V)$
Maximum Package Power Dissipation @ 25°C ⁽³⁾	
NFE Package	1520 mW
NAJ Package	2000 mW
Short Circuit Duration, D_{OUT}	Continuous
Storage Temp. Range	-65°C to +150°C
Lead Temp. (Soldering, 4 sec.)	+260°C
ESD Rating	
(HMB, 1.5 k Ω , 100 pF)	≥ 2.5 kV

- (1) "Absolute Maximum Ratings" are those values beyond which the safety of the device cannot be verified. They are not meant to imply that the devices should be operated at these limits. The tables of "Electrical Characteristics" specify conditions for device operation.
- (2) For complete Military Product Specifications, refer to the appropriate SMD or MDS.
- (3) Ratings apply to ambient temperature at +25°C. Above this temperature derate: NFE Package 12.2 mW/°C and NAJ Package 13.3 mW/°C.

Recommended Operating Conditions

	Min	Max	Units
Supply Voltage, V_{CC}	4.5	5.5	V
Operating Free Air Temp. (T_A)			
DS14C232E/J	-55	+125	°C

Electrical Characteristics⁽¹⁾

Over recommended operating conditions, unless otherwise specified

Symbol	Parameter	Conditions	Min	Max	Units
DEVICE CHARACTERISTICS (C1–C4 = 1.0 μF)					
I_{CC}	Supply (V_{CC}) Current	No Load		8.0	mA
DRIVER CHARACTERISTICS					
V_{IH}	High Level Input Voltage		2		V
V_{IL}	Low Level Input Voltage			0.8	V
I_{IH}	High Level Input Current	$V_{IN} \geq 2.0V$		100	μ A
I_{IL}	Low Level Input Current	$V_{IN} = 0V$		100	μ A
V_{OH}	High Level Output Voltage	$R_L = 3$ k Ω	5.0		V
V_{OL}	Low Level Output Voltage	$R_L = 3$ k Ω		-5.0	V
I_{OS+}	Output High Short Circuit Current	$V_O = 0V$	See ⁽²⁾	-25	mA
I_{OS-}	Output Low Short Circuit Current	$V_O = 0V$		25	mA
R_O	Output Resistance	$-2V \leq V_O \leq +2V$, $T_A = 25^\circ C$, $V_{CC} = 0V = GND$	300		Ω

- (1) All typicals are given for $V_{CC} = 5.0V$.
- (2) I_{OS+} and I_{OS-} values are for one output at a time. If more than one output is shorted simultaneously, the device power dissipation may be exceeded.

Electrical Characteristics⁽¹⁾ (continued)

Over recommended operating conditions, unless otherwise specified

Symbol	Parameter	Conditions	Min	Max	Units
RECEIVER CHARACTERISTICS (C1–C4 = 1.0 μF)					
V _{TH}	Input High Threshold Voltage			3.0	V
V _{TL}	Input Low Threshold Voltage		0.2		V
V _{HY}	Hysteresis	T _A = 25°C, +125°C	0.1	1.0	V
		T _A = -55°C	0.05	1.0	V
R _{IN}	Input Resistance	V _{IN} = \pm 3V and \pm 15V, T _A = 25°C	3.0	7.0	k Ω
V _{OH}	High Level Output Voltage	I _O = -3.2 mA	3.5		V
		I _O = -20 μ A	4.0		V
V _{OL}	Low Level Output Voltage	I _O = +3.2 mA		0.4	V

Switching Characteristics

Over recommended operating conditions, unless otherwise specified.

Symbol	Parameter	Conditions	Min	Max	Units
DRIVER CHARACTERISTICS (C1–C4 = 1.0 μF)					
t _{PLH}	Propagation Delay Low to High	R _L = 3 k Ω , C _L = 50 pF	(Figure 5, Figure 6)	4.0	μ s
t _{PHL}	Propagation Delay High to Low			4.0	μ s
t _{SK}	Skew t _{PLH} - t _{PHL}			1.0	μ s
SR1	Output Slew Rate	R _L = 3 k Ω to 7 k Ω , C _L = 2500 pF	See ⁽¹⁾	1.5	30 V/ μ s
RECEIVER CHARACTERISTICS (C1–C4 = 1.0 μF)					
t _{PLH}	Propagation Delay Low to High	Input Pulse Width > 10 μ s		8.0	μ s
t _{PHL}	Propagation Delay High to Low	C _L = 50 pF		8.0	μ s
t _{SK}	Skew t _{PLH} - t _{PHL}	(Figure 7, Figure 8)		2.0	μ s

(1) Slew rate is defined as $\Delta V/\Delta t$, measured between $\pm 3V$ level.

Connection Diagrams

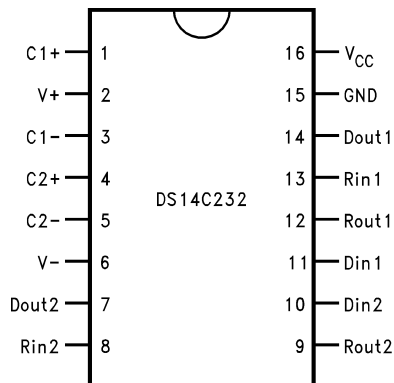

Figure 3. 16-Lead CDIP
See NFE Package

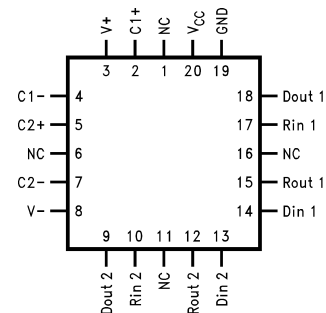

Figure 4. 20-Lead LCCC
See NAJ Package

For Complete Military Product Specifications see MDS or SMD

Parameter Measurement Information

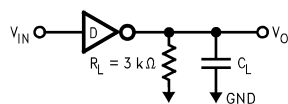

Figure 5. Driver Load Circuit

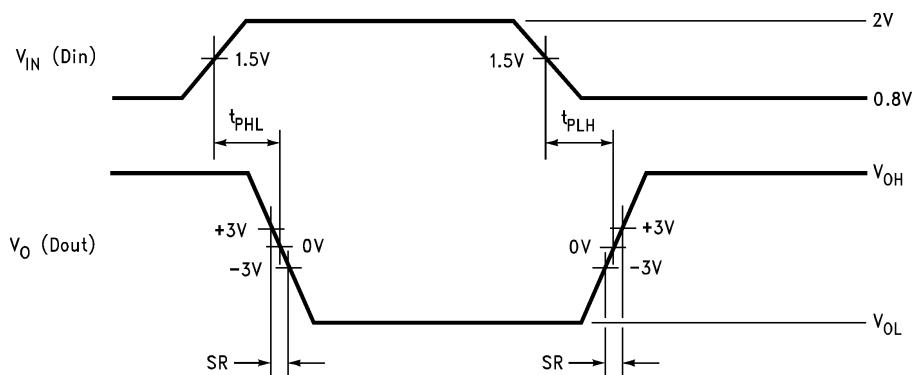

Figure 6. Driver Switching Waveform

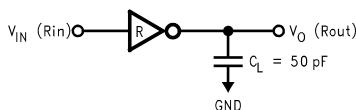
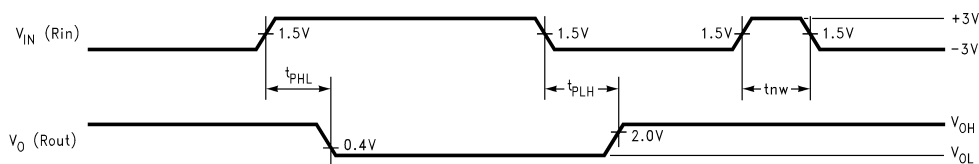

Figure 7. Receiver Load Circuit



A. Receiver AC input waveform for test purposes: $t_r = t_f = 200$ ns, $V_{IH} = 3V$, $V_{IL} = -3V$, $f = 30$ kHz.

Figure 8. Receiver Propagation Delays and Noise Rejection

PIN DESCRIPTIONS

V_{CC} (Pin 16)

Power supply pin for the device, +5V ($\pm 10\%$).

V₊ (Pin 2)

Positive supply for TIA/EIA-232-E drivers. Recommended external capacitor: C4-1.0 μF (6.3V). Capacitor value should be larger than 1 μF . This supply is not intended to be loaded externally.

V₋ (Pin 6)

Negative supply for TIA/EIA-232-E drivers. Recommended external capacitor: C3-1.0 μF (16V). Capacitor value should be larger than 1 μF . This supply is not intended to be loaded externally.

C1₊, C1₋ (Pins 1, 3)

External capacitor connection pins. Recommended capacitor: 1.0 μF (6.3V). Capacitor value should be larger than 1 μF .

C2₊, C2₋ (Pins 4, 5)

External capacitor connection pins. Recommended capacitor: 1.0 μF (16V). Capacitor value should be greater than 1 μF .

D_{IN1}, D_{IN2} (Pins 11, 10)

Driver input pins are TTL/CMOS compatible. Inputs of unused drivers may be left open, an internal active pull-up resistor (500 k Ω minimum, typically 5 M Ω) pulls input HIGH. Output will be LOW for open inputs.

D_{OUT1}, D_{OUT2} (Pins 14, 7)

Driver output pins conform to TIA/EIA-232-E levels.

R_{IN1}, R_{IN2} (Pins 13, 8)

Receiver input pins accept TIA/EIA-232-E input voltages ($\pm 25\text{V}$). Receivers feature a noise filter and specified hysteresis of 100 mV. Unused receiver input pins may be left open. Internal input resistor 4.7 k Ω pulls input low, providing a failsafe high output.

R_{OUT1}, R_{OUT2} (Pins 12, 9)

Receiver output pins are TTL/CMOS compatible. Receiver output HIGH voltage is specified for both CMOS and TTL load conditions.

GND (Pin 15)

Ground Pin.

TYPICAL APPLICATION INFORMATION

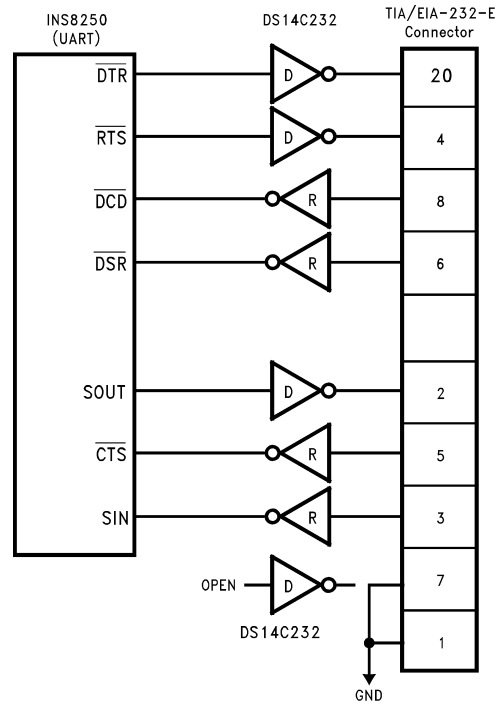

Figure 9. Application of DS14C232 and INS8250

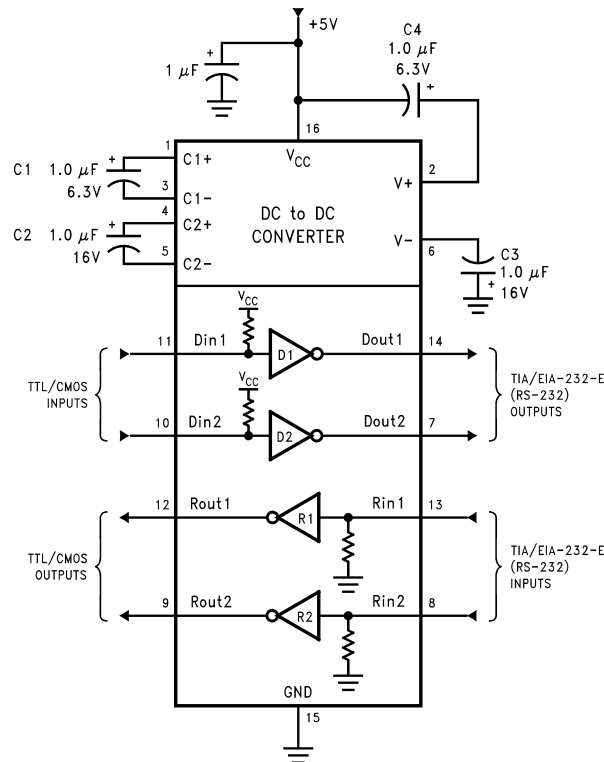

Figure 10. Typical Connection Diagram

Typical Performance Characteristics

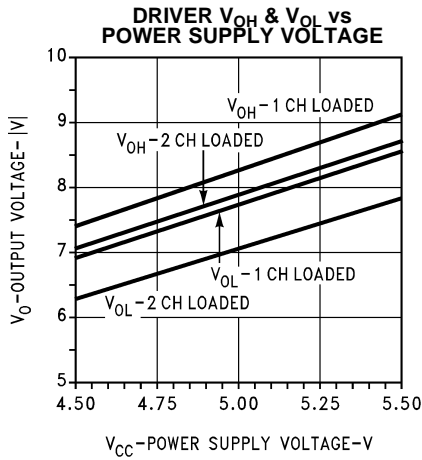

Figure 11.

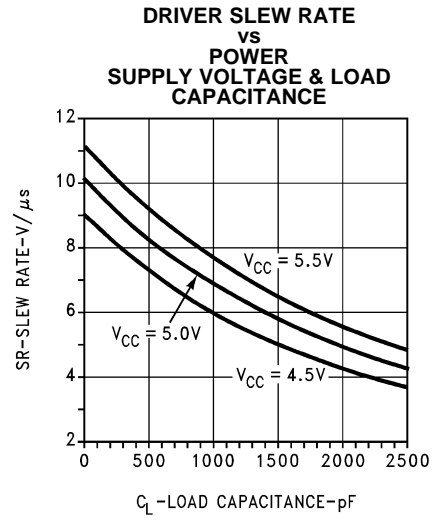
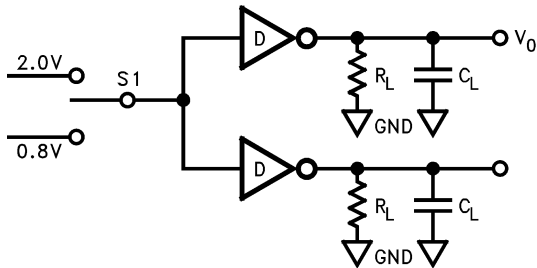
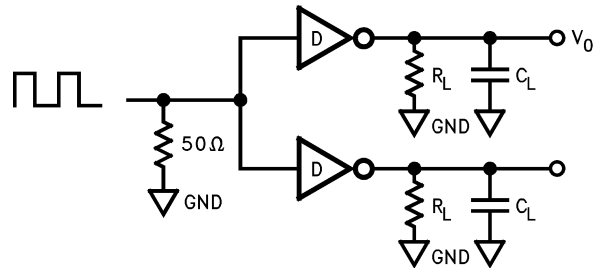

Figure 12.



$V_{CC} = 5.0V$, $R_L = 3 k\Omega$, $C_L = 15 pF$ (includes jig and probe capacitance), $C_P = 1 \mu F$

Figure 13.



$T_a = 25^\circ C$, $R_L = 5 k\Omega$, $C_P = 1 \mu F$, $f = 30 KHz$

Figure 14.

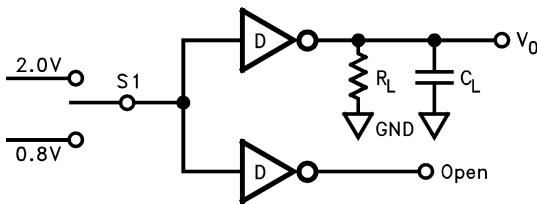

$S1 = 2.0V$, $V_O = V_{OL}$

Figure 15.



Figure 16.

REVISION HISTORY

Changes from Revision B (April 2013) to Revision C	Page
<hr/> <ul style="list-style-type: none">• Changed layout of National Data Sheet to TI format	<hr/> 10

PACKAGING INFORMATION

Orderable Device	Status (1)	Package Type	Package Drawing	Pins	Package Qty	Eco Plan (2)	Lead/Ball Finish (6)	MSL Peak Temp (3)	Op Temp (°C)	Device Marking (4/5)	Samples
DS14C232CM	OBSOLETE	SOIC	D	16		TBD	Call TI	Call TI	0 to 70	DS14C232CM	
DS14C232CM/NOPB	OBSOLETE	SOIC	D	16		TBD	Call TI	Call TI	0 to 70	DS14C232CM	
DS14C232CMX/NOPB	OBSOLETE	SOIC	D	16		TBD	Call TI	Call TI	0 to 70	DS14C232CM	
DS14C232CN/NOPB	OBSOLETE	PDIP	NFG	16		TBD	Call TI	Call TI	0 to 70	DS14C232CN	
DS14C232TM	OBSOLETE	SOIC	D	16		TBD	Call TI	Call TI	-40 to 85	DS14C232TM	
DS14C232TM/NOPB	OBSOLETE	SOIC	D	16		TBD	Call TI	Call TI	-40 to 85	DS14C232TM	
DS14C232TMX	NRND	SOIC	D	16		TBD	Call TI	Call TI	-40 to 85	DS14C232TM	
DS14C232TMX/NOPB	OBSOLETE	SOIC	D	16		TBD	Call TI	Call TI	-40 to 85	DS14C232TM	

(1) The marketing status values are defined as follows:

ACTIVE: Product device recommended for new designs.

LIFEBUY: TI has announced that the device will be discontinued, and a lifetime-buy period is in effect.

NRND: Not recommended for new designs. Device is in production to support existing customers, but TI does not recommend using this part in a new design.

PREVIEW: Device has been announced but is not in production. Samples may or may not be available.

OBSOLETE: TI has discontinued the production of the device.

(2) Eco Plan - The planned eco-friendly classification: Pb-Free (RoHS), Pb-Free (RoHS Exempt), or Green (RoHS & no Sb/Br) - please check <http://www.ti.com/productcontent> for the latest availability information and additional product content details.

TBD: The Pb-Free/Green conversion plan has not been defined.

Pb-Free (RoHS): TI's terms "Lead-Free" or "Pb-Free" mean semiconductor products that are compatible with the current RoHS requirements for all 6 substances, including the requirement that lead not exceed 0.1% by weight in homogeneous materials. Where designed to be soldered at high temperatures, TI Pb-Free products are suitable for use in specified lead-free processes.

Pb-Free (RoHS Exempt): This component has a RoHS exemption for either 1) lead-based flip-chip solder bumps used between the die and package, or 2) lead-based die adhesive used between the die and leadframe. The component is otherwise considered Pb-Free (RoHS compatible) as defined above.

Green (RoHS & no Sb/Br): TI defines "Green" to mean Pb-Free (RoHS compatible), and free of Bromine (Br) and Antimony (Sb) based flame retardants (Br or Sb do not exceed 0.1% by weight in homogeneous material)

(3) MSL, Peak Temp. - The Moisture Sensitivity Level rating according to the JEDEC industry standard classifications, and peak solder temperature.

(4) There may be additional marking, which relates to the logo, the lot trace code information, or the environmental category on the device.

(5) Multiple Device Markings will be inside parentheses. Only one Device Marking contained in parentheses and separated by a "~" will appear on a device. If a line is indented then it is a continuation of the previous line and the two combined represent the entire Device Marking for that device.

(6) Lead/Ball Finish - Orderable Devices may have multiple material finish options. Finish options are separated by a vertical ruled line. Lead/Ball Finish values may wrap to two lines if the finish value exceeds the maximum column width.

Important Information and Disclaimer: The information provided on this page represents TI's knowledge and belief as of the date that it is provided. TI bases its knowledge and belief on information provided by third parties, and makes no representation or warranty as to the accuracy of such information. Efforts are underway to better integrate information from third parties. TI has taken and continues to take reasonable steps to provide representative and accurate information but may not have conducted destructive testing or chemical analysis on incoming materials and chemicals. TI and TI suppliers consider certain information to be proprietary, and thus CAS numbers and other limited information may not be available for release.

In no event shall TI's liability arising out of such information exceed the total purchase price of the TI part(s) at issue in this document sold by TI to Customer on an annual basis.

N0016E

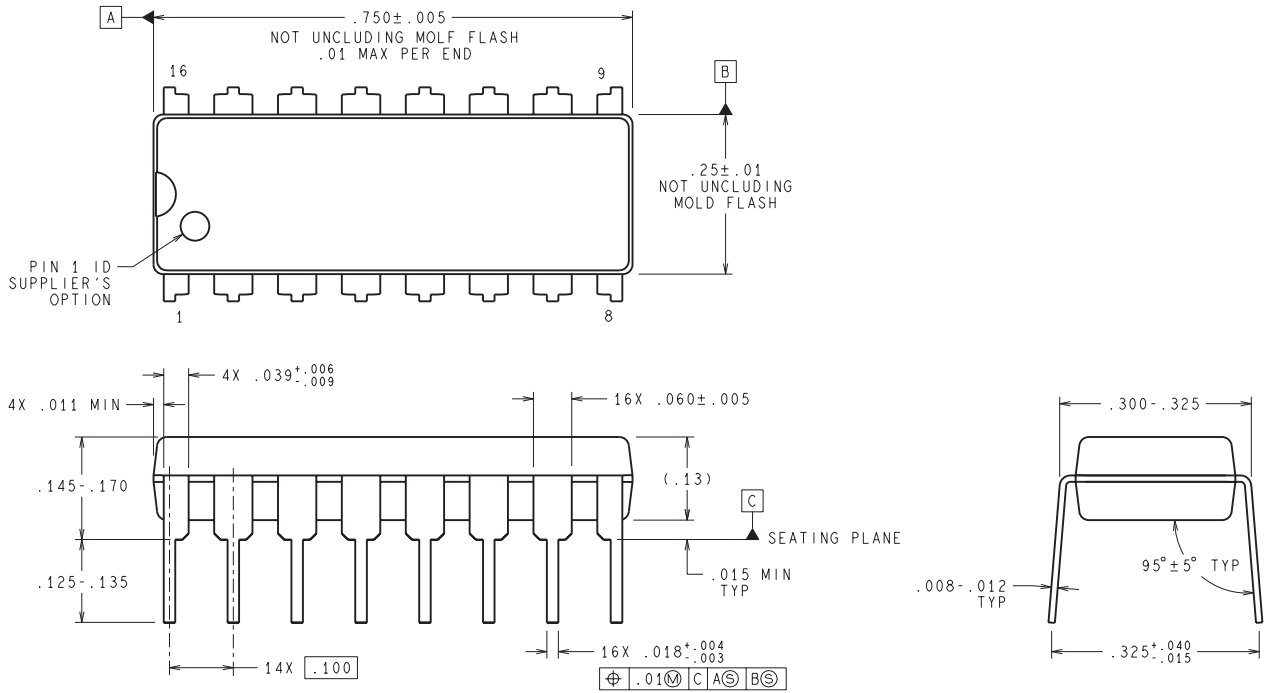

DIMENSIONS ARE IN INCHES
DIMENSIONS IN () FOR REFERENCE ONLY

N16E (Rev G)

D (R-PDSO-G16)

PLASTIC SMALL OUTLINE



- NOTES:
- A. All linear dimensions are in inches (millimeters).
 - B. This drawing is subject to change without notice.
 - C. Body length does not include mold flash, protrusions, or gate burrs. Mold flash, protrusions, or gate burrs shall not exceed 0.006 (0,15) each side.
 - D. Body width does not include interlead flash. Interlead flash shall not exceed 0.017 (0,43) each side.
 - E. Reference JEDEC MS-012 variation AC.

IMPORTANT NOTICE

Texas Instruments Incorporated and its subsidiaries (TI) reserve the right to make corrections, enhancements, improvements and other changes to its semiconductor products and services per JESD46, latest issue, and to discontinue any product or service per JESD48, latest issue. Buyers should obtain the latest relevant information before placing orders and should verify that such information is current and complete. All semiconductor products (also referred to herein as "components") are sold subject to TI's terms and conditions of sale supplied at the time of order acknowledgment.

TI warrants performance of its components to the specifications applicable at the time of sale, in accordance with the warranty in TI's terms and conditions of sale of semiconductor products. Testing and other quality control techniques are used to the extent TI deems necessary to support this warranty. Except where mandated by applicable law, testing of all parameters of each component is not necessarily performed.

TI assumes no liability for applications assistance or the design of Buyers' products. Buyers are responsible for their products and applications using TI components. To minimize the risks associated with Buyers' products and applications, Buyers should provide adequate design and operating safeguards.

TI does not warrant or represent that any license, either express or implied, is granted under any patent right, copyright, mask work right, or other intellectual property right relating to any combination, machine, or process in which TI components or services are used. Information published by TI regarding third-party products or services does not constitute a license to use such products or services or a warranty or endorsement thereof. Use of such information may require a license from a third party under the patents or other intellectual property of the third party, or a license from TI under the patents or other intellectual property of TI.

Reproduction of significant portions of TI information in TI data books or data sheets is permissible only if reproduction is without alteration and is accompanied by all associated warranties, conditions, limitations, and notices. TI is not responsible or liable for such altered documentation. Information of third parties may be subject to additional restrictions.

Resale of TI components or services with statements different from or beyond the parameters stated by TI for that component or service voids all express and any implied warranties for the associated TI component or service and is an unfair and deceptive business practice. TI is not responsible or liable for any such statements.

Buyer acknowledges and agrees that it is solely responsible for compliance with all legal, regulatory and safety-related requirements concerning its products, and any use of TI components in its applications, notwithstanding any applications-related information or support that may be provided by TI. Buyer represents and agrees that it has all the necessary expertise to create and implement safeguards which anticipate dangerous consequences of failures, monitor failures and their consequences, lessen the likelihood of failures that might cause harm and take appropriate remedial actions. Buyer will fully indemnify TI and its representatives against any damages arising out of the use of any TI components in safety-critical applications.

In some cases, TI components may be promoted specifically to facilitate safety-related applications. With such components, TI's goal is to help enable customers to design and create their own end-product solutions that meet applicable functional safety standards and requirements. Nonetheless, such components are subject to these terms.

No TI components are authorized for use in FDA Class III (or similar life-critical medical equipment) unless authorized officers of the parties have executed a special agreement specifically governing such use.

Only those TI components which TI has specifically designated as military grade or "enhanced plastic" are designed and intended for use in military/aerospace applications or environments. Buyer acknowledges and agrees that any military or aerospace use of TI components which have **not** been so designated is solely at the Buyer's risk, and that Buyer is solely responsible for compliance with all legal and regulatory requirements in connection with such use.

TI has specifically designated certain components as meeting ISO/TS16949 requirements, mainly for automotive use. In any case of use of non-designated products, TI will not be responsible for any failure to meet ISO/TS16949.

Products

Audio	www.ti.com/audio
Amplifiers	amplifier.ti.com
Data Converters	dataconverter.ti.com
DLP® Products	www.dlp.com
DSP	dsp.ti.com
Clocks and Timers	www.ti.com/clocks
Interface	interface.ti.com
Logic	logic.ti.com
Power Mgmt	power.ti.com
Microcontrollers	microcontroller.ti.com
RFID	www.ti-rfid.com
OMAP Applications Processors	www.ti.com/omap
Wireless Connectivity	www.ti.com/wirelessconnectivity

Applications

Automotive and Transportation	www.ti.com/automotive
Communications and Telecom	www.ti.com/communications
Computers and Peripherals	www.ti.com/computers
Consumer Electronics	www.ti.com/consumer-apps
Energy and Lighting	www.ti.com/energy
Industrial	www.ti.com/industrial
Medical	www.ti.com/medical
Security	www.ti.com/security
Space, Avionics and Defense	www.ti.com/space-avionics-defense
Video and Imaging	www.ti.com/video

TI E2E Community

e2e.ti.com

Looking for pricing, stock, or lifecycle information?

Click below to explore more details on WIN SOURCE:

 [View DS14C232TMX/NOPB on WIN SOURCE](#)

 [Texas Instruments](#) Information

Optimize Your Supply Chain with WIN SOURCE Solutions

-  Global Sourcing Solution
-  Obsolete Management
-  Cost Control Management
-  Shortage Management
-  Alternative Solution
-  Excess Inventory Management