



**THE DATASHEET OF
9DBL0951BKILF**



Description

The 9DBL09x1 devices are 3.3V members of IDT's Full-Featured PCIe clock family. The 9DBL09x1 devices support PCIe Gen1–4 Common Clocked (CC) and PCIe Separate Reference Independent Spread (SRIS) systems. They offer a choice of integrated output terminations providing direct connection to 85Ω or 100Ω transmission lines. The 9DBL09P1 can be factory programmed with a user-defined power up default SMBus configuration.

Recommended Application

PCIe Gen1–4 clock distribution for Riser Cards, Storage, Networking, JBOD, Communications, Access Points

Output Features

- 9 – 1-200 MHz Low-Power (LP) HCSL DIF pairs
 - 9DBL0941 default Zout = 100Ω
 - 9DBL0951 default Zout = 85Ω
 - 9DBL09P1 factory programmable defaults
- Easy AC-coupling to other logic families, see IDT application note [AN-891](#).

Key Specifications

- DIF *additive* cycle-to-cycle jitter < 5ps
- DIF output-to-output skew < 50ps
- *Additive* phase jitter is 0ps (typical rms) for PCIe Gen1–4 CC, SRIS
- *Additive* phase jitter 111fs rms typical at 156.25M (1.5M to 10M)

Block Diagram

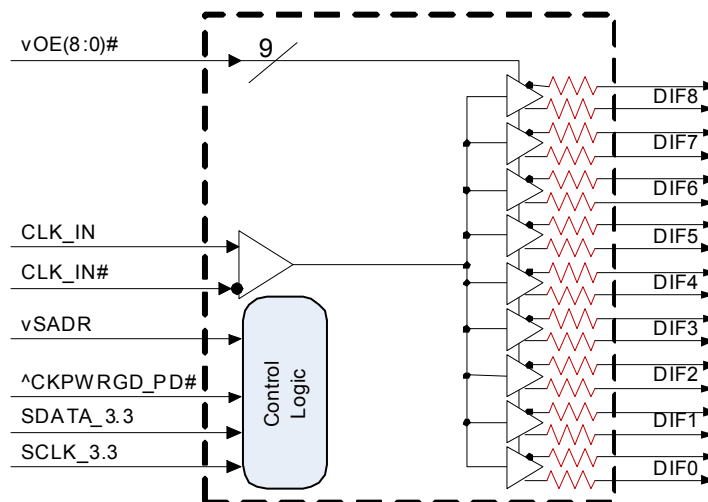

Note: Resistors default to internal on 41/51 devices. P1 devices have programmable default impedances on an output-by-output basis.

Features/Benefits

- Direct connection to 100Ω (xx41) or 85Ω (xx51) transmission lines; saves 36 resistors compared to standard PCIe devices
- 165mW typical power consumption (at 3.3V); eliminates thermal concerns
- VDDIO allows 50% power savings at optional 1.05V; maximum power savings
- SMBus-selectable features allows optimization to customer requirements:
 - control input polarity
 - control input pull up/downs
 - slew rate for each output
 - differential output amplitude
 - output impedance for each output
- Customer defined SMBus power up default can be programmed into P1 device; allows exact optimization to customer requirements
- OE# pins; support DIF power management
- HCSL differential input; can be driven by common clock sources
- Spread spectrum tolerant; allows reduction of EMI
- Device contains default configuration; SMBus interface not required for device operation
- Three selectable SMBus addresses; multiple devices can easily share an SMBus segment
- Space saving 48-pin 6 x 6mm VFQFPN; minimal board space

Pin Configuration

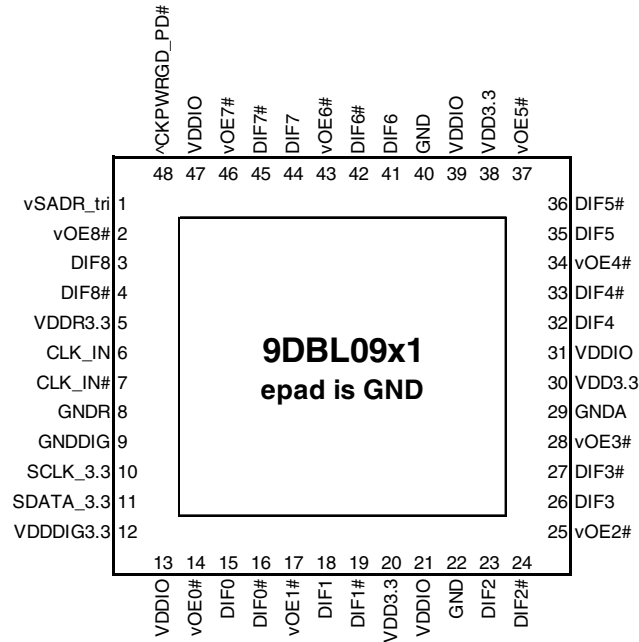

48-pin VFQFPN, 6x6 mm, 0.4mm pitch

^v prefix indicates internal 120KOhm pull up *AND* pull down resistor (biased to VDD/2)

v prefix indicates internal 120KOhm pull down resistor

^ prefix indicates internal 120KOhm pull up resistor

SMBus Address Selection Table

	SADR	Address	+ Read/Write bit
State of SADR on first application of CKPWRGD_PD#	0	1101011	x
	M	1101100	x
	1	1101101	x

Note: If not using CKPWRGD (i.e., CKPWRGD tied to VDD3.3), all 3.3V VDD need to transition from 2.1V to 3.135V in <300usec.

Power Management Table

CKPWRGD_PD#	CLK_IN	SMBus OEx bit	OEx# Pin	DIFx	
				True O/P	Comp. O/P
0	X	X	X	Low ¹	Low ¹
1	Running	0	X	Low ¹	Low ¹
1	Running	1	0	Running	Running
1	Running	1	1	Low ¹	Low ¹

1. The output state is set by B11[1:0] (Low/Low default)

Power Connections

Pin Number			Description
VDD	VDDIO	GND	
5		8	Input receiver analog
12		9	Digital Power
20,30,31,38	13,21,31,39,47	22,29,40,49	DIF outputs

Pin Descriptions

PIN #	PIN NAME	TYPE	DESCRIPTION
1	vSADR_tri	LATCHED IN	Tri-level latch to select SMBus Address. See SMBus Address Selection Table.
2	vOE8#	IN	Active low input for enabling DIF pair 8. This pin has an internal pull-down. 1 =disable outputs, 0 = enable outputs
3	DIF8	OUT	Differential true clock output
4	DIF8#	OUT	Differential Complementary clock output
5	VDDR3.3	PWR	3.3V power for differential input clock (receiver). This VDD should be treated as an Analog power rail and filtered appropriately.
6	CLK_IN	IN	True Input for differential reference clock.
7	CLK_IN#	IN	Complementary Input for differential reference clock.
8	GNDR	GND	Analog Ground pin for the differential input (receiver)
9	GNDDIG	GND	Ground pin for digital circuitry
10	SCLK_3.3	IN	Clock pin of SMBus circuitry, 3.3V tolerant.
11	SDATA_3.3	I/O	Data pin for SMBus circuitry, 3.3V tolerant.
12	VDDDIG3.3	PWR	3.3V digital power (dirty power)
13	VDDIO	PWR	Power supply for differential outputs
14	vOE0#	IN	Active low input for enabling DIF pair 0. This pin has an internal pull-down. 1 =disable outputs, 0 = enable outputs
15	DIF0	OUT	Differential true clock output
16	DIF0#	OUT	Differential Complementary clock output
17	vOE1#	IN	Active low input for enabling DIF pair 1. This pin has an internal pull-down. 1 =disable outputs, 0 = enable outputs
18	DIF1	OUT	Differential true clock output
19	DIF1#	OUT	Differential Complementary clock output
20	VDD3.3	PWR	Power supply, nominal 3.3V
21	VDDIO	PWR	Power supply for differential outputs
22	GND	GND	Ground pin.
23	DIF2	OUT	Differential true clock output
24	DIF2#	OUT	Differential Complementary clock output
25	vOE2#	IN	Active low input for enabling DIF pair 2. This pin has an internal pull-down. 1 =disable outputs, 0 = enable outputs
26	DIF3	OUT	Differential true clock output
27	DIF3#	OUT	Differential Complementary clock output
28	vOE3#	IN	Active low input for enabling DIF pair 3. This pin has an internal pull-down. 1 =disable outputs, 0 = enable outputs
29	GNDA	GND	Ground pin for the PLL core.
30	VDD3.3	PWR	Power supply, nominal 3.3V
31	VDDIO	PWR	Power supply for differential outputs
32	DIF4	OUT	Differential true clock output
33	DIF4#	OUT	Differential Complementary clock output
34	vOE4#	IN	Active low input for enabling DIF pair 4. This pin has an internal pull-down. 1 =disable outputs, 0 = enable outputs
35	DIF5	OUT	Differential true clock output
36	DIF5#	OUT	Differential Complementary clock output
37	vOE5#	IN	Active low input for enabling DIF pair 5. This pin has an internal pull-down. 1 =disable outputs, 0 = enable outputs
38	VDD3.3	PWR	Power supply, nominal 3.3V
39	VDDIO	PWR	Power supply for differential outputs
40	GND	GND	Ground pin.

Pin Descriptions (cont.)

PIN #	PIN NAME	TYPE	DESCRIPTION
41	DIF6	OUT	Differential true clock output
42	DIF6#	OUT	Differential Complementary clock output
43	vOE6#	IN	Active low input for enabling DIF pair 6. This pin has an internal pull-down. 1 =disable outputs, 0 = enable outputs
44	DIF7	OUT	Differential true clock output
45	DIF7#	OUT	Differential Complementary clock output
46	vOE7#	IN	Active low input for enabling DIF pair 7. This pin has an internal pull-down. 1 =disable outputs, 0 = enable outputs
47	VDDIO	PWR	Power supply for differential outputs
48	^CKPWRGD_PD#	IN	Input notifies device to sample latched inputs and start up on first high assertion. Low enters Power Down Mode, subsequent high assertions exit Power Down Mode. This pin has internal pull-up resistor.
49	EPAD	GND	Connect to Ground.

Test Loads

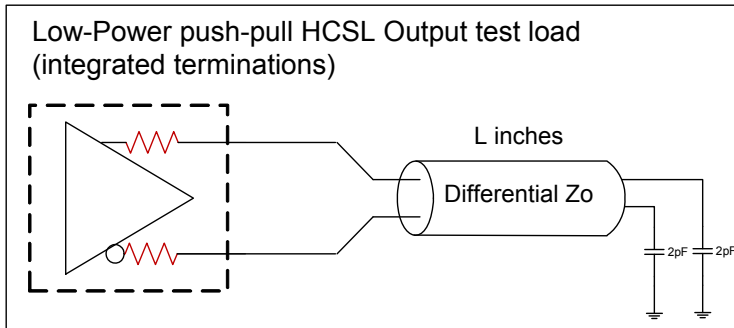

L = 5 inches

Alternate Terminations

The 9DBL family can easily drive LVPECL, LVDS, and CML logic. See [“AN-891 Driving LVPECL, LVDS, and CML Logic with IDT's "Universal" Low-Power HCSL Outputs”](#) for details.

Terminations

Device	Zo (Ω)	Rs (Ω)
9DBL0941	100	None needed
9DBL0951	100	7.5
9DBL09P1	100	Prog.
9DBL0941	85	N/A
9DBL0951	85	None needed
9DBL09P1	85	Prog.

Absolute Maximum Ratings

Stresses above the ratings listed below can cause permanent damage to the 9DBL09x1. These ratings, which are standard values for IDT commercially rated parts, are stress ratings only. Functional operation of the device at these or any other conditions above those indicated in the operational sections of the specifications is not implied. Exposure to absolute maximum rating conditions for extended periods can affect product reliability. Electrical parameters are guaranteed only over the recommended operating temperature range.

PARAMETER	SYMBOL	CONDITIONS	MIN	TYP	MAX	UNITS	NOTES
Supply Voltage	VDDx				4.6	V	1,2
Input Voltage	V _{IN}		-0.5		V _{DD} +0.5	V	1,3
Input High Voltage, SMBus	V _{IHSMB}	SMBus clock and data pins			3.9	V	1
Storage Temperature	T _s		-65		150	°C	1
Junction Temperature	T _j				125	°C	1
Input ESD protection	ESD prot	Human Body Model	2500			V	1

¹Guaranteed by design and characterization, not 100% tested in production.

²Operation under these conditions is neither implied nor guaranteed.

³Not to exceed 4.6V.

Electrical Characteristics–SMBus Parameters

TA = T_{AMB}, Supply Voltages per normal operation conditions, See Test Loads for Loading Conditions

PARAMETER	SYMBOL	CONDITIONS	MIN	TYP	MAX	UNITS	NOTES
SMBus Input Low Voltage	V _{ILSMB}	V _{DD} SMB = 3.3V			0.8	V	
SMBus Input High Voltage	V _{IHSMB}	V _{DD} SMB = 3.3V	2.1		3.6	V	
SMBus Output Low Voltage	V _{OLSMB}	@ I _{PULLUP}			0.4	V	
SMBus Sink Current	I _{PULLUP}	@ V _{OL}	4			mA	
Nominal Bus Voltage	V _{DD} SMB		2.7		3.6	V	
SCLK/SDATA Rise Time	t _{RSMB}	(Max VIL - 0.15) to (Min VIH + 0.15)			1000	ns	1
SCLK/SDATA Fall Time	t _{FSMB}	(Min VIH + 0.15) to (Max VIL - 0.15)			300	ns	1
SMBus Operating Frequency	f _{SMB}	SMBus operating frequency			500	kHz	2,3

¹Guaranteed by design and characterization, not 100% tested in production.

²The device must be powered up for the SMBus to function.

³The differential input clock must be running for the SMBus to be active

Electrical Characteristics–Clock Input Parameters

TA = T_{AMB}, Supply Voltages per normal operation conditions, See Test Loads for Loading Conditions

PARAMETER	SYMBOL	CONDITIONS	MIN	TYP	MAX	UNITS	NOTES
Input Crossover Voltage - DIF_IN	V _{CROSS}	Cross Over Voltage	150		900	mV	1
Input Swing - DIF_IN	V _{SWING}	Differential value	300			mV	1
Input Slew Rate - DIF_IN	dv/dt	Measured differentially	0.4		8	V/ns	1,2
Input Leakage Current	I _{IN}	V _{IN} = V _{DD} , V _{IN} = GND	-5		5	uA	
Input Duty Cycle	d _{tin}	Measurement from differential waveform	45		55	%	1
Input Jitter - Cycle to Cycle	J _{DIFIn}	Differential Measurement	0		125	ps	1

¹Guaranteed by design and characterization, not 100% tested in production.

²Slew rate measured through +/-75mV window centered around differential zero

Electrical Characteristics–Input/Supply/Common Parameters–Normal Operating Conditions

TA = T_{AMB}, Supply Voltages per normal operation conditions, See Test Loads for Loading Conditions

PARAMETER	SYMBOL	CONDITIONS	MIN	TYP	MAX	UNITS	NOTES
Supply Voltage	V _{DDx}	Supply voltage for core and analog	3.135	3.3	3.465	V	
Output Supply Voltage	V _{DDIO}	Supply voltage for Low Power HCSL Outputs	0.95	1.05-3.3	3.465	V	
Ambient Operating Temperature	T _{AMB}	Industrial range	-40	25	85	°C	
Input High Voltage	V _{IH}	Single-ended inputs, except SMBus	0.75 V _{DDx}		V _{DDx} + 0.3	V	
Input Low Voltage	V _{IL}		-0.3		0.25 V _{DDx}	V	
Input High Voltage	V _{IHtri}	Single-ended tri-level inputs ('_tri' suffix)	0.75 V _{DDx}		V _{DD} + 0.3	V	
Input Mid Voltage	V _{IMtri}		0.4 V _{DDx}	0.5 V _{DDx}	0.6 V _{DDx}	V	
Input Low Voltage	V _{ILtri}		-0.3		0.25 V _{DDx}	V	
Input Current	I _{IN}	Single-ended inputs, V _{IN} = GND, V _{IN} = VDD	-5		5	uA	
	I _{INP}	Single-ended inputs V _{IN} = 0 V; Inputs with internal pull-up resistors V _{IN} = VDD; Inputs with internal pull-down resistors	-50		50	uA	
Input Frequency	F _{IN}		1		200	MHz	2
Pin Inductance	L _{pin}				7	nH	1
Capacitance	C _{IN}	Logic Inputs, except DIF_IN	1.5		5	pF	1
	C _{INDIF_IN}	DIF_IN differential clock inputs	1.5		2.7	pF	1
	C _{OUT}	Output pin capacitance			6	pF	1
Clk Stabilization	T _{STAB}	From V _{DD} Power-Up and after input clock stabilization or de-assertion of PD# to 1st clock			1	ms	1,2
Input SS Modulation Frequency PCIe	f _{MODINPCIe}	Allowable Frequency for PCIe Applications (Triangular Modulation)	30		33	kHz	
Input SS Modulation Frequency non-PCIe	f _{MODIN}	Allowable Frequency for non-PCIe Applications (Triangular Modulation)	0		66	kHz	
OE# Latency	t _{LATOE#}	DIF start after OE# assertion DIF stop after OE# deassertion	1		3	clocks	1,3
Tdrive_PD#	t _{DRVPD}	DIF output enable after PD# de-assertion			300	us	1,3
Tfall	t _F	Fall time of single-ended control inputs			5	ns	2
Trise	t _R	Rise time of single-ended control inputs			5	ns	2

¹Guaranteed by design and characterization, not 100% tested in production.

²Control input must be monotonic from 20% to 80% of input swing.

³Time from deassertion until outputs are >200 mV

Electrical Characteristics–DIF Low-Power HCSL Outputs

TA = T_{AMB}, Supply Voltages per normal operation conditions, See Test Loads for Loading Conditions

PARAMETER	SYMBOL	CONDITIONS	MIN	TYP	MAX	UNITS	NOTES
Slew rate	dV/dt	Scope averaging on, fast setting	1.7	2.7	4	V/ns	1,2,3
	dV/dt	Scope averaging on, slow setting	0.8	1.9	2.8	V/ns	1,2,3
Slew rate matching	Δ dV/dt	Slew rate matching		6	20	%	1,4
Voltage High	V _{HIGH}	Statistical measurement on single-ended signal using oscilloscope math function. (Scope averaging on)	660	783	850	mV	7
Voltage Low	V _{LOW}		-150	-17	150		7
Max Voltage	V _{max}	Measurement on single ended signal using absolute value. (Scope averaging off)		818	1150	mV	7
Min Voltage	V _{min}		-300	-54			7
Crossing Voltage (abs)	V _{cross_abs}	Scope averaging off	250	377	550	mV	1,5
Crossing Voltage (var)	Δ -V _{cross}	Scope averaging off		18	140	mV	1,6

¹Guaranteed by design and characterization, not 100% tested in production.

² Measured from differential waveform

³ Slew rate is measured through the V_{swing} voltage range centered around differential 0V. This results in a +/-150mV window around differential 0V.

⁴ Matching applies to rising edge rate for Clock and falling edge rate for Clock#. It is measured using a +/-75mV window centered on the average cross point where Clock rising meets Clock# falling. The median cross point is used to calculate the voltage thresholds the oscilloscope is to use for the edge rate calculations.

⁵ V_{cross} is defined as voltage where Clock = Clock# measured on a component test board and only applies to the differential rising edge (i.e. Clock rising and Clock# falling).

⁶ The total variation of all V_{cross} measurements in any particular system. Note that this is a subset of V_{cross_min/max} (V_{cross} absolute) allowed. The intent is to limit V_{cross} induced modulation by setting Δ -V_{cross} to be smaller than V_{cross} absolute.

⁷ At default SMBus settings.

Electrical Characteristics–Current Consumption

TA = T_{AMB}, Supply Voltages per normal operation conditions, See Test Loads for Loading Conditions

PARAMETER	SYMBOL	CONDITIONS	MIN	TYP	MAX	UNITS	NOTES
Operating Supply Current	I _{DD}	VDD + VDDR All outputs active @100MHz, 100 Loads		13	20	mA	
	I _{DDDIG}	VDDDIG All outputs active @100MHz, 100 Loads		0.4	0.8	mA	
	I _{DDIO}	VDDIO All outputs active @100MHz, 100 Loads		36	40	mA	
Powerdown Current	I _{DDPD}	VDD + VDDR, CKPWRGD_PD#=0		1	2	mA	2
	I _{DDDIGPD}	VDDDIG, CKPWRGD_PD#=0		0.4	0.8	mA	2
	I _{DDIOPD}	VDDIO, CKPWRGD_PD#=0		0.04	0.1	mA	2

¹ Guaranteed by design and characterization, not 100% tested in production.

² Input clock stopped.

Electrical Characteristics–Output Duty Cycle, Jitter, and Skew Characteristics

TA = T_{AMB}, Supply Voltages per normal operation conditions, See Test Loads for Loading Conditions

PARAMETER	SYMBOL	CONDITIONS	MIN	TYP	MAX	UNITS	NOTES
Duty Cycle Distortion	t _{DCD}	Measured differentially, 100MHz	-1	-0.1	1	%	3
Skew, Input to Output	t _{pd}	V _T = 50%	2200	2982	4000	ps	2
Skew, Output to Output	t _{sk3}	V _T = 50%		43	50	ps	2,4
Jitter, Cycle to cycle	t _{jcy-cyc}	Additive Jitter		0.1	1	ps	2

¹ Applies to all differential outputs, guaranteed by design and characterization.

² Measured from differential waveform

³ Duty cycle distortion is the difference in duty cycle between the output and the input clock when the device is operated in bypass mode.

⁴ All outputs at same slew rate

Electrical Characteristics–Filtered Phase Jitter Parameters - PCIe Common Clocked (CC) Architectures^{1,5}

T_{AMB} = over the specified operating range. Supply Voltages per normal operation conditions, See Test Loads for Loading Conditions

PARAMETER	SYMBOL	CONDITIONS	MIN	TYP	MAX	INDUSTRY LIMIT	UNITS	Notes
Additive Phase Jitter	t _{jphPCIeG1-CC}	PCIe Gen 1		0.4	2	n/a	ps (p-p)	2,3
	t _{jphPCIeG2-CC}	PCIe Gen 2 Lo Band 10kHz < f < 1.5MHz (PLL BW of 5-16MHz or 8-5MHz, CDR = 5MHz)		0.0	0.1		ps (rms)	2,4
		PCIe Gen 2 High Band 1.5MHz < f < Nyquist (50MHz) (PLL BW of 5-16MHz or 8-5MHz, CDR = 5MHz)		0.24	0.5		ps (rms)	2,4
	t _{jphPCIeG3-CC}	PCIe Gen 3 (PLL BW of 2-4MHz or 2-5MHz, CDR = 10MHz)		0.07	0.15		ps (rms)	2,4
	t _{jphPCIeG4-CC}	PCIe Gen 4 (PLL BW of 2-4MHz or 2-5MHz, CDR = 10MHz)		0.07	0.15		ps (rms)	2,4

¹ Applies to all differential outputs, guaranteed by design and characterization.

² Based on PCIe Base Specification Rev4.0 version 0.7draft. See <http://www.pcisig.com> for latest specifications.

³ Sample size of at least 100K cycles. This figures extrapolates to 108ps pk-pk @ 1M cycles for a BER of 1-12.

⁴ For RMS values additive jitter is calculated by solving the following equation for b [$a^2 + b^2 = c^2$] where a is rms input jitter and c is rms total jitter.

⁵ Driven by 9FGL0841 or equivalent

Electrical Characteristics—Filtered Phase Jitter Parameters - PCIe Separate Reference Independent Spread (SRIS) Architectures¹

T_{AMB} = over the specified operating range. Supply Voltages per normal operation conditions, See Test Loads for Loading Conditions

PARAMETER	SYMBOL	CONDITIONS	MIN	TYP	MAX	INDUSTRY LIMIT	UNITS	Notes
Additive Phase Jitter	t _{jphPCIeG1-SRIS}	PCIe Gen 1	TBD			Note 5	ps (pk-pk)	2,3
	t _{jphPCIeG2-SRIS}	PCIe Gen 2 (PLL BW of 16MHz , CDR = 5MHz)		0.3	0.4		ps (rms)	2
	t _{jphPCIeG3-SRIS}	PCIe Gen 3 (PLL BW of 2-4MHz or 2-5MHz, CDR = 10MHz)		0.03	0.13		ps (rms)	2
	t _{jphPCIeG4-SRIS}	PCIe Gen 4 (PLL BW of 2-4MHz or 2-5MHz, CDR = 10MHz)	TBD				ps (rms)	2

¹ Applies to all differential outputs, guaranteed by design and characterization.

² Based PCIe Base Specification Rev3.1a filters. These filters are different than Common Clock filters. See <http://www.pcisig.com> for latest specifications and are not defined for Gen1 or Gen4

³ Sample size of at least 100K cycles. This figures extrapolates to 108ps pk-pk @ 1M cycles for a BER of 1-12.

⁴ For RMS values, additive jitter is calculated by solving the following equation for b [$a^2 + b^2 = c^2$] where a is rms input jitter and c is rms total jitter.

⁵ As of PCIe Base Specification Rev4.0 draft 0.7, SRIS limits are defined as implementation dependent.

Electrical Characteristics—Unfiltered Phase Jitter Parameters¹

T_A = T_{AMB}, Supply Voltages per normal operation conditions, See Test Loads for Loading Conditions

PARAMETER	SYMBOL	CONDITIONS	MIN	TYP	MAX	INDUSTRY LIMIT	UNITS	Notes
Additive Phase Jitter	t _{jph156M}	156.25MHz, 1.5MHz to 10MHz, -20dB/decade rollover < 1.5MHz, -40db/decade rolloff > 10MHz		111		N/A	fs (rms)	2,3
	t _{jph156M12k-20}	156.25MHz, 12kHz to 20MHz, -20dB/decade rollover < 12kHz, -40db/decade rolloff > 20MHz		272		N/A	fs (rms)	2,3

¹ Applies to all differential outputs, guaranteed by design and characterization.

² Driven by Rohde & Schartz SMA100

³ For RMS values, additive jitter is calculated by solving the following equation for b [$a^2 + b^2 = c^2$] where a is rms input jitter and c is rms total jitter.

General SMBus Serial Interface Information

How to Write

- Controller (host) sends a start bit
- Controller (host) sends the write address
- IDT clock will **acknowledge**
- Controller (host) sends the beginning byte location = N
- IDT clock will **acknowledge**
- Controller (host) sends the byte count = X
- IDT clock will **acknowledge**
- Controller (host) starts sending Byte N through Byte N+X-1
- IDT clock will **acknowledge** each byte **one at a time**
- Controller (host) sends a Stop bit

Index Block Write Operation			
Controller (Host)			IDT (Slave/Receiver)
T	starT bit		
Slave Address			
WR	WRite		
			ACK
Beginning Byte = N			
			ACK
Data Byte Count = X			
			ACK
Beginning Byte N		X Byte	
			ACK
O			O
O			O
O			O
Byte N + X - 1			
			ACK
P	stoP bit		

How to Read

- Controller (host) will send a start bit
- Controller (host) sends the write address
- IDT clock will **acknowledge**
- Controller (host) sends the beginning byte location = N
- IDT clock will **acknowledge**
- Controller (host) will send a separate start bit
- Controller (host) sends the read address
- IDT clock will **acknowledge**
- IDT clock will send the data byte count = X
- IDT clock sends Byte N+X-1
- IDT clock sends **Byte 0 through Byte X (if X_(H) was written to Byte 8)**
- Controller (host) will need to acknowledge each byte
- Controller (host) will send a not acknowledge bit
- Controller (host) will send a stop bit

Index Block Read Operation			
Controller (Host)			IDT (Slave/Receiver)
T	starT bit		
Slave Address			
WR	WRite		
			ACK
Beginning Byte = N			
			ACK
RT	Repeat starT		
Slave Address			
RD	ReaD		
			ACK
			Data Byte Count=X
ACK		X Byte	
ACK			Beginning Byte N
			O
			O
			O
			Byte N + X - 1
N	Not acknowledge		
P	stoP bit		

Note: SMBus Address is Latched on SADR pin. Unless otherwise indicated, default values are for the xx41 and xx51. P1 devices are fully factory programmable.

SMBus Table: Output Enable Register ¹

Byte 0	Name	Control Function	Type	0	1	Default
Bit 7	DIF OE7	Output Enable	RW	Low/Low	Enabled	1
Bit 6	DIF OE6	Output Enable	RW	Low/Low	Enabled	1
Bit 5	DIF OE5	Output Enable	RW	Low/Low	Enabled	1
Bit 4	DIF OE4	Output Enable	RW	Low/Low	Enabled	1
Bit 3	DIF OE3	Output Enable	RW	Low/Low	Enabled	1
Bit 2	DIF OE2	Output Enable	RW	Low/Low	Enabled	1
Bit 1	DIF OE1	Output Enable	RW	Low/Low	Enabled	1
Bit 0	DIF OE0	Output Enable	RW	Low/Low	Enabled	1

1. A low on these bits will override the OE# pin and force the differential output to the state indicated by B11[1:0] (Low/Low default)

SMBus Table: Output Enable and Output Amplitude Control Register

Byte 1	Name	Control Function	Type	0	1	Default
Bit 7	Reserved					0
Bit 6	Reserved					1
Bit 5	DIF OE8	Output Enable	RW	Low/Low	Enabled	1
Bit 4	Reserved					0
Bit 3	Reserved					1
Bit 2	Reserved					1
Bit 1	AMPLITUDE 1	Controls Output Amplitude	RW	00 = 0.6V	01 = 0.68V	1
Bit 0	AMPLITUDE 0		RW	10 = 0.75V	11 = 0.85V	0

1. A low on these bits will override the OE# pin and force the differential output to the state indicated by B11[1:0] (Low/Low default)

SMBus Table: DIF Slew Rate Control Register

Byte 2	Name	Control Function	Type	0	1	Default
Bit 7	SLEWRATESEL DIF7	Adjust Slew Rate of DIF7	RW	Slow Setting	Fast Setting	1
Bit 6	SLEWRATESEL DIF6	Adjust Slew Rate of DIF6	RW	Slow Setting	Fast Setting	1
Bit 5	SLEWRATESEL DIF5	Adjust Slew Rate of DIF5	RW	Slow Setting	Fast Setting	1
Bit 4	SLEWRATESEL DIF4	Adjust Slew Rate of DIF4	RW	Slow Setting	Fast Setting	1
Bit 3	SLEWRATESEL DIF3	Adjust Slew Rate of DIF3	RW	Slow Setting	Fast Setting	1
Bit 2	SLEWRATESEL DIF2	Adjust Slew Rate of DIF2	RW	Slow Setting	Fast Setting	1
Bit 1	SLEWRATESEL DIF1	Adjust Slew Rate of DIF1	RW	Slow Setting	Fast Setting	1
Bit 0	SLEWRATESEL DIF0	Adjust Slew Rate of DIF0	RW	Slow Setting	Fast Setting	1

Note: See "Low-Power HCSSL Outputs" table for slew rates.

SMBus Table: DIF Slew Rate Control Register

Byte 3	Name	Control Function	Type	0	1	Default
Bit 7	Reserved					1
Bit 6	Reserved					1
Bit 5	Reserved					0
Bit 4	Reserved					0
Bit 3	Reserved					0
Bit 2	Reserved					1
Bit 1	Reserved					1
Bit 0	SLEWRATESEL DIF8	Adjust Slew Rate of DIF8	RW	Slow Setting	Fast Setting	1

Note: See "Low-Power HCSSL Outputs" table for slew rates.

Byte 4 is Reserved and reads back 'hFF'

SMBus Table: Revision and Vendor ID Register

Byte 5	Name	Control Function	Type	0	1	Default
Bit 7	RID3	Revision ID	R	B rev = 0001		0
Bit 6	RID2		R			0
Bit 5	RID1		R			0
Bit 4	RID0		R			1
Bit 3	VID3	VENDOR ID	R	0001 = IDT		0
Bit 2	VID2		R			0
Bit 1	VID1		R			0
Bit 0	VID0		R			1

SMBus Table: Device Type/Device ID

Byte 6	Name	Control Function	Type	0	1	Default
Bit 7	Device Type1	Device Type	R	00 = FGx, 01 = DBx, 10 = DMx, 11= DBx w/oPLL		1
Bit 6	Device Type0		R			1
Bit 5	Device ID5	Device ID	R	001001binary or 09 hex		0
Bit 4	Device ID4		R			0
Bit 3	Device ID3		R			1
Bit 2	Device ID2		R			0
Bit 1	Device ID1		R			0
Bit 0	Device ID0		R			1

SMBus Table: Byte Count Register

Byte 7	Name	Control Function	Type	0	1	Default
Bit 7		Reserved				0
Bit 6		Reserved				0
Bit 5		Reserved				0
Bit 4	BC4	Byte Count Programming	RW	Writing to this register will configure how many bytes will be read back, default is = 8 bytes.		0
Bit 3	BC3		RW			1
Bit 2	BC2		RW			0
Bit 1	BC1		RW			0
Bit 0	BC0		RW			0

Bytes 8 and 9 are Reserved

SMBus Table: PLL MN Enable, PD_Restore

Byte 10	Name	Control Function	Type	0	1	Default
Bit 7		Reserved				1
Bit 6	Power-Down (PD) Restore	Restore Default Config. In PD	RW	Clear Config in PD	Keep Config in PD	1
Bit 5		Reserved				0
Bit 4		Reserved				0
Bit 3		Reserved				0
Bit 2		Reserved				0
Bit 1		Reserved				0
Bit 0		Reserved				0

SMBus Table: Impedance Control

Byte 11	Name	Control Function	Type	0	1	Default
Bit 7	DIF8_imp[1]	DIF8 Zout	RW	00=33Ω DIF Zout	10=100Ω DIF Zout	see Note
Bit 6	DIF8_imp[0]		RW	01=85Ω DIF Zout	11 = Reserved	
Bit 5	Reserved					0
Bit 4	Reserved					0
Bit 3	Reserved					0
Bit 2	Reserved					0
Bit 1	STP[1]	True/Complement DIF Output Disable State	RW	00 = Low/Low	10 = High/Low	0
Bit 0	STP[0]		RW	01 = HiZ/HiZ	11 = Low/High	0

Note: xx41 = 10, xx51 = 01, P1 = factory programmable.

SMBus Table: Impedance Control

Byte 12	Name	Control Function	Type	0	1	Default
Bit 7	DIF3_imp[1]	DIF3 Zout	RW	00=33Ω DIF Zout	10=100Ω DIF Zout	see Note
Bit 6	DIF3_imp[0]	DIF3 Zout	RW	01=85Ω DIF Zout	11 = Reserved	
Bit 5	DIF2_imp[1]	DIF2 Zout	RW	00=33Ω DIF Zout	10=100Ω DIF Zout	
Bit 4	DIF2_imp[0]	DIF2 Zout	RW	01=85Ω DIF Zout	11 = Reserved	
Bit 3	DIF1_imp[1]	DIF1 Zout	RW	00=33Ω DIF Zout	10=100Ω DIF Zout	
Bit 2	DIF1_imp[0]	DIF1 Zout	RW	01=85Ω DIF Zout	11 = Reserved	
Bit 1	DIF0_imp[1]	DIF0 Zout	RW	00=33Ω DIF Zout	10=100Ω DIF Zout	
Bit 0	DIF0_imp[0]	DIF0 Zout	RW	01=85Ω DIF Zout	11 = Reserved	

Note: xx41 = 10, xx51 = 01, P1 = factory programmable.

SMBus Table: Impedance Control

Byte 13	Name	Control Function	Type	0	1	Default
Bit 7	DIF7_imp[1]	DIF7 Zout	RW	00=33Ω DIF Zout	10=100Ω DIF Zout	see Note
Bit 6	DIF7_imp[0]	DIF7 Zout	RW	01=85Ω DIF Zout	11 = Reserved	
Bit 5	DIF6_imp[1]	DIF6 Zout	RW	00=33Ω DIF Zout	10=100Ω DIF Zout	
Bit 4	DIF6_imp[0]	DIF6 Zout	RW	01=85Ω DIF Zout	11 = Reserved	
Bit 3	DIF5_imp[1]	DIF5 Zout	RW	00=33Ω DIF Zout	10=100Ω DIF Zout	
Bit 2	DIF5_imp[0]	DIF5 Zout	RW	01=85Ω DIF Zout	11 = Reserved	
Bit 1	DIF4_imp[1]	DIF4 Zout	RW	00=33Ω DIF Zout	10=100Ω DIF Zout	
Bit 0	DIF4_imp[0]	DIF4 Zout	RW	01=85Ω DIF Zout	11 = Reserved	

Note: xx41 = 10, xx51 = 01, P1 = factory programmable.

SMBus Table: Pull-up Pull-down Control

Byte 14	Name	Control Function	Type	0	1	Default
Bit 7	OE3_pu/pd[1]	OE3 Pull-up(PuP)/ Pull-down(Pdwn) control	RW	00=None	10=Pup	0
Bit 6	OE3_pu/pd[0]		RW	01=Pdwn	11 = Pup+Pdwn	1
Bit 5	OE2_pu/pd[1]	OE2 Pull-up(PuP)/ Pull-down(Pdwn) control	RW	00=None	10=Pup	0
Bit 4	OE2_pu/pd[0]		RW	01=Pdwn	11 = Pup+Pdwn	1
Bit 3	OE1_pu/pd[1]	OE1 Pull-up(PuP)/ Pull-down(Pdwn) control	RW	00=None	10=Pup	0
Bit 2	OE1_pu/pd[0]		RW	01=Pdwn	11 = Pup+Pdwn	1
Bit 1	OE0_pu/pd[1]	OE0 Pull-up(PuP)/ Pull-down(Pdwn) control	RW	00=None	10=Pup	0
Bit 0	OE0_pu/pd[0]		RW	01=Pdwn	11 = Pup+Pdwn	1

Note: These values are for xx41 and xx51. P1 is factory programmable.

SMBus Table: Pull-up Pull-down Control

Byte 15	Name	Control Function	Type	0	1	Default
Bit 7	OE7_pu/pd[1]	OE7 Pull-up(PuP)/ Pull-down(Pdwn) control	RW	00=None	10=Pup	0
Bit 6	OE7_pu/pd[0]		RW	01=Pdwn	11 = Pup+Pdwn	1
Bit 5	OE6_pu/pd[1]	OE6 Pull-up(PuP)/ Pull-down(Pdwn) control	RW	00=None	10=Pup	0
Bit 4	OE6_pu/pd[0]		RW	01=Pdwn	11 = Pup+Pdwn	1
Bit 3	OE5_pu/pd[1]	OE5 Pull-up(PuP)/ Pull-down(Pdwn) control	RW	00=None	10=Pup	0
Bit 2	OE5_pu/pd[0]		RW	01=Pdwn	11 = Pup+Pdwn	1
Bit 1	OE4_pu/pd[1]	OE4 Pull-up(PuP)/ Pull-down(Pdwn) control	RW	00=None	10=Pup	0
Bit 0	OE4_pu/pd[0]		RW	01=Pdwn	11 = Pup+Pdwn	1

Note: These values are for xx41 and xx51. P1 is factory programmable.

SMBus Table: Pull-up Pull-down Control

Byte 16	Name	Control Function	Type	0	1	Default
Bit 7		Reserved				0
Bit 6		Reserved				0
Bit 5		Reserved				1
Bit 4		Reserved				0
Bit 3	OE8_pu/pd[1]	OE8 Pull-up(PuP)/ Pull-down(Pdwn) control	RW	00=None	10=Pup	0
Bit 2	OE8_pu/pd[0]		RW	01=Pdwn	11 = Pup+Pdwn	1
Bit 1	CKPWRGD_PD_pu/pd[1]	CKPWRGD_PD Pull-up(PuP)/ Pull-down(Pdwn) control	RW	00=None	10=Pup	1
Bit 0	CKPWRGD_PD_pu/pd[0]		RW	01=Pdwn	11 = Pup+Pdwn	0

Note: These values are for xx41 and xx51. P1 is factory programmable.

Bytes 17 is Reserved and reads back 0h00.

SMBus Table: Polarity Control

Byte 18	Name	Control Function	Type	0	1	Default
Bit 7	OE7_polarity	Sets OE7 polarity	RW	Enabled when Low	Enabled when High	0
Bit 6	OE6_polarity	Sets OE6 polarity	RW	Enabled when Low	Enabled when High	0
Bit 5	OE5_polarity	Sets OE5 polarity	RW	Enabled when Low	Enabled when High	0
Bit 4	OE4_polarity	Sets OE4 polarity	RW	Enabled when Low	Enabled when High	0
Bit 3	OE3_polarity	Sets OE3 polarity	RW	Enabled when Low	Enabled when High	0
Bit 2	OE2_polarity	Sets OE2 polarity	RW	Enabled when Low	Enabled when High	0
Bit 1	OE1_polarity	Sets OE1 polarity	RW	Enabled when Low	Enabled when High	0
Bit 0	OE0_polarity	Sets OE0 polarity	RW	Enabled when Low	Enabled when High	0

SMBus Table: Polarity Control

Byte 19	Name	Control Function	Type	0	1	Default
Bit 7		Reserved				0
Bit 6		Reserved				0
Bit 5		Reserved				0
Bit 4		Reserved				0
Bit 3		Reserved				0
Bit 2		Reserved				0
Bit 1	OE8_polarity	Determines OE9 polarity	RW	Enabled when Low	Enabled when High	0
Bit 0	CKPWRGD_PD	Determines CKPWRGD_PD polarity	RW	Power Down when Low	Power Down when High	0

Marking Diagrams

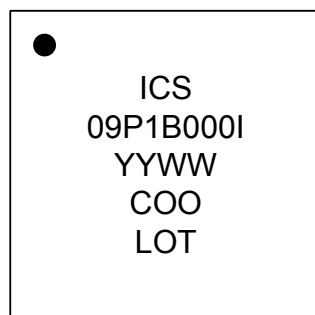
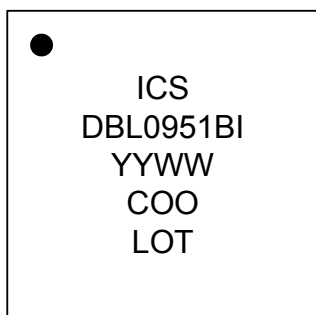
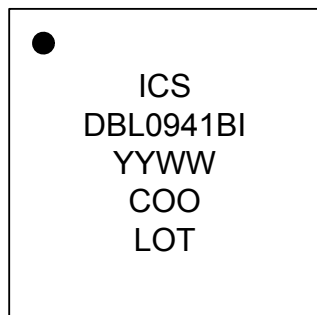

Notes:

1. "LOT" is the lot sequence number.
2. "COO" denotes country of origin.
3. "YYWW" is the last two digits of the year and week that the part was assembled.
4. Line 2: truncated part number
5. "I" denotes industrial temperature range device.

Thermal Characteristics

PARAMETER	SYMBOL	CONDITIONS	PKG	TYP VALUE	UNITS	NOTES
Thermal Resistance	θ_{JC}	Junction to Case	NDG48	33	°C/W	1
	θ_{Jb}	Junction to Base		2.1	°C/W	1
	$\theta_{JA0\theta}$	Junction to Air, still air		37	°C/W	1
	θ_{JA1}	Junction to Air, 1 m/s air flow		30	°C/W	1
	θ_{JA3}	Junction to Air, 3 m/s air flow		27	°C/W	1
	θ_{JA5}	Junction to Air, 5 m/s air flow		26	°C/W	1

¹ePad soldered to board

REVISIONS	
REV	DESCRIPTION
00	INITIAL RELEASE

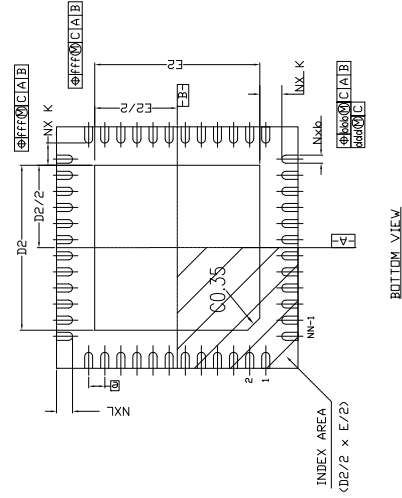
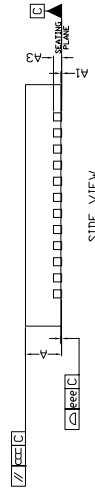
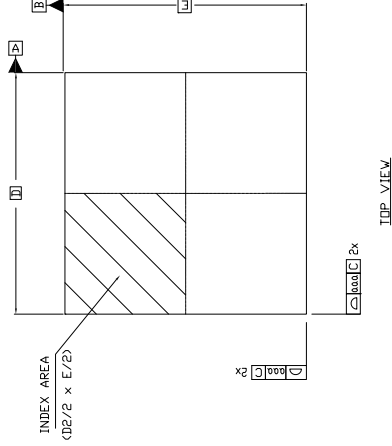

NOTES:

1. ALL DIMENSIONING AND TOLERANCING CONFORM TO ANSI Y14.5M-1982
2. ALL DIMENSIONS ARE IN MILLIMETERS.
3. N REFERS TO THE NUMBER OF LEADS.
4. ND AND NE REFER TO THE NUMBER OF LEADS PER SIDE.

SYMBOL	DIMENSION	
	MIN	MAX
D2	3.95	4.10
E2	3.95	4.10
L	0.30	0.40
K	0.55 REF	
D	6.00 BSC	
E	6.00 BSC	
e	0.40 BSC	
A	0.80	0.90
A1	0.00	0.02
A3	---	0.20 REF
N	48	
ND	12	
NE	12	
b	0.15	0.20
TOLERANCE of FORM & POSITION		
aaa	0.10	
bbb	0.07	
ccc	0.10	
ddd	0.05	
eee	0.08	
fff	0.10	

TOLERANCES UNLESS SPECIFIED IN DECIMAL XXX± ANGULAR ±1° APPROVALS DRAWN CHECKED	TITLE	ND/NDG 48
	DATE	01/11/08
	DRAWN	ØA/C
	CHECKED	
SIZE		C
DRAWING No.		PS
DO NOT SCALE DRAWING		

www.IDT.com
 6.0 x 6.0 mm
 0.40 mm PL

Ordering Information

Part / Order Number	Output Impedance	Shipping Packaging	Package	Temperature
9DBL0941BKILF	100Ω	Trays	48-pin VFQFPN	-40 to +85° C
9DBL0941BKILFT		Tape and Reel	48-pin VFQFPN	-40 to +85° C
9DBL0951BKILF	85Ω	Trays	48-pin VFQFPN	-40 to +85° C
9DBL0951BKILFT		Tape and Reel	48-pin VFQFPN	-40 to +85° C
9DBL09P1BxxxKILF	Factory configurable. Contact IDT for additional information.	Trays	48-pin VFQFPN	-40 to +85° C
9DBL09P1BxxxKILFT		Tape and Reel	48-pin VFQFPN	-40 to +85° C

“LF” suffix to the part number are the Pb-Free configuration and are RoHS compliant.

“B” is the device revision designator (will not correlate with the datasheet revision).

“xxx” is a unique factory assigned number to identify a particular default configuration.

Revision History

Rev.	Initiator	Issue Date	Description	Page #
A	RDW	9/16/2016	<ol style="list-style-type: none"> 1. Updated front page text 2. Changed VDDA3.3 pin to VDD3.3, since this part has no PLL 3. Removed references to PLL mode, since this part has no PLL 4. Regrouped IDD values to simplify the table 5. Updated Electrical tables to latest version, including PCIe Gen4 6. Updated ordering information to B rev 7. Corrected readback of Smbus B1[1:0], B3[7], B5[4], B10[7], B16[5] - most of these are reserved bits 8. Updated footnote text under block diagram. 9. Updated block diagram for stylistic consistency. 10. Updated electrical tables with char data, move to final. 	Various
B	RDW	9/26/2016	<ol style="list-style-type: none"> 1. Corrected Byte 11[1:0] bit definitions. 	13
C	RDW	8/1/2017	Removed reference to differential waveform in slew rate matching spec	7

IMPORTANT NOTICE AND DISCLAIMER

RENESAS ELECTRONICS CORPORATION AND ITS SUBSIDIARIES (“RENESAS”) PROVIDES TECHNICAL SPECIFICATIONS AND RELIABILITY DATA (INCLUDING DATASHEETS), DESIGN RESOURCES (INCLUDING REFERENCE DESIGNS), APPLICATION OR OTHER DESIGN ADVICE, WEB TOOLS, SAFETY INFORMATION, AND OTHER RESOURCES “AS IS” AND WITH ALL FAULTS, AND DISCLAIMS ALL WARRANTIES, EXPRESS OR IMPLIED, INCLUDING, WITHOUT LIMITATION, ANY IMPLIED WARRANTIES OF MERCHANTABILITY, FITNESS FOR A PARTICULAR PURPOSE, OR NON-INFRINGEMENT OF THIRD-PARTY INTELLECTUAL PROPERTY RIGHTS.

These resources are intended for developers who are designing with Renesas products. You are solely responsible for (1) selecting the appropriate products for your application, (2) designing, validating, and testing your application, and (3) ensuring your application meets applicable standards, and any other safety, security, or other requirements. These resources are subject to change without notice. Renesas grants you permission to use these resources only to develop an application that uses Renesas products. Other reproduction or use of these resources is strictly prohibited. No license is granted to any other Renesas intellectual property or to any third-party intellectual property. Renesas disclaims responsibility for, and you will fully indemnify Renesas and its representatives against, any claims, damages, costs, losses, or liabilities arising from your use of these resources. Renesas' products are provided only subject to Renesas' Terms and Conditions of Sale or other applicable terms agreed to in writing. No use of any Renesas resources expands or otherwise alters any applicable warranties or warranty disclaimers for these products.

(Disclaimer Rev.1.01 Jan 2024)

Corporate Headquarters

TOYOSU FORESIA, 3-2-24 Toyosu,
Koto-ku, Tokyo 135-0061, Japan
www.renesas.com

Trademarks

Renesas and the Renesas logo are trademarks of Renesas Electronics Corporation. All trademarks and registered trademarks are the property of their respective owners.

Contact Information

For further information on a product, technology, the most up-to-date version of a document, or your nearest sales office, please visit www.renesas.com/contact-us/.

Looking for pricing, stock, or lifecycle information?

Click below to explore more details on WIN SOURCE:

-  [View 9DBL0951BKILF on WIN SOURCE](#)
-  [Renesas Electronics America](#) Information

Optimize Your Supply Chain with WIN SOURCE Solutions

-  Global Sourcing Solution
-  Obsolete Management
-  Cost Control Management
-  Shortage Management
-  Alternative Solution
-  Excess Inventory Management