



**THE DATASHEET OF
ESP-WROOM-02U-N4**



ESP-WROOM-02D/02U

Datasheet

Includes:

ESP-WROOM-02D

ESP-WROOM-02U

Note:

It is recommended to use the upgraded model: [ESP8684-WROOM-02C/02UC](#)



Version 2.2
Espressif Systems
Copyright © 2023

About This Guide

This document provides introduction to the specifications of ESP-WROOM-02D and ESP-WROOM-02U hardware.

Release Notes

Date	Version	Release notes
2017.11	V1.0	First release.
2018.03	V1.1	Updated the figure of ESP-WROOM-02U dimensions.
2018.08	V1.2	<ul style="list-style-type: none">• Updated Table 1-1 and Table 1-2;• Updated module dimensions;• Added PCB pattern;• Updated document cover.
2019.04	V1.3	<ul style="list-style-type: none">• Added MSL information in table 1-2;• Added notes in Figure 5-1 and Figure 5-2.
2019.08	V1.4	Updated Chapter 6 Peripheral Schematics.
2019.12	V1.5	<ul style="list-style-type: none">• Added a note for the reflow profile;• Added feedback links.
2019.12	V1.6	Updated a typo in ESP-WROOM-02D dimensions.
2020.07	V1.7	<ul style="list-style-type: none">• Updated Note in Chapter 6;• Updated links in Appendix.
2022.03	V1.8	Added a link to RF certification in Table 1-2
2022.07	V1.9	<ul style="list-style-type: none">• Updated links in Appendix;• Added Chapter 10 Product Handling.
2023.02	v2.0	Added description about footprint in Chapter 8.
2023.05	v2.1	Added ordering information in Table 1-1.
2023.06	v2.2	<ul style="list-style-type: none">• Added a note on the cover page;• Updated two documents in Appendix.

Documentation Change Notification

Espressif provides email notifications to keep customers updated on changes to technical documentation. Please subscribe at <https://www.espressif.com/en/subscribe>.

Certification

Download certificates for Espressif products from <https://www.espressif.com/en/certificates>.

Table of Contents

1. Overview	1
2. Pin Description	3
3. Functional Description	5
3.1. CPU	5
3.2. Memory	5
3.2.1. Internal SRAM and ROM	5
3.2.2. SPI Flash	5
3.3. Crystal Oscillator	6
3.4. Interface Description	6
4. Electrical Characteristics	8
4.1. Electrical Characteristics	8
4.2. Wi-Fi Radio	8
4.3. Power Consumption	9
4.4. Reflow Profile	10
4.5. Electrostatic Discharge	11
5. Schematics	12
6. Peripheral Schematics	14
7. Dimensions	15
8. Recommended PCB Land Pattern	17
9. U.FL Connector Dimensions	19
10. Product Handling	20
10.1. Storage Conditions	20
10.2. Electrostatic Discharge (ESD)	20
10.3. Ultrasonic Vibration	20
A. Appendix—Learning Resources	21
A.1. Must-Read Documents	21
A.2. Must-Have Resources	22



1.

Overview

ESP-WROOM-02D and ESP-WROOM-02U are ESP8266EX-based modules developed by Espressif. Compared to ESP-WROOM-02, the RF performance of ESP-WROOM-02D and ESP-WROOM-02U are optimized. Besides, ESP-WROOM-02U integrates a U.FL connector. Please see [Chapter 8](#) for details of U.FL connector.

Table 1-1. ESP-WROOM-02D vs. ESP-WROOM-02U-1

Ordering Code	Antenna	In-Package Flash	Ambient Temp	Size (mm)
ESP-WROOM-02D-H2	Onboard antenna	2 MB	-40 °C ~ 105 °C	(18.00 ± 0.10) x (20.00 ± 0.10) x (3.20 ± 0.10)
ESP-WROOM-02D-N2		2 MB		
ESP-WROOM-02D-N4		4 MB	-40 °C ~ 85 °C	
ESP-WROOM-02D-N16		16 MB		
ESP-WROOM-02U-H2	IPEX antenna	2 MB	-40 °C ~ 105 °C	(18.00 ± 0.10) x (14.30 ± 0.10) x (3.20 ± 0.10)
ESP-WROOM-02U-N2		2 MB		
ESP-WROOM-02U-N4		4 MB	-40 °C ~ 85 °C	
ESP-WROOM-02U-N16		16 MB		

Note:

For more information on ESP8266EX, please refer to [ESP8266EX Datasheet](#).

Table 1-2. ESP-WROOM-02D/ESP-WROOM-02U Specifications

Categories	Items	Specifications
Certification	RF certification	See certificates from ESP-WROOM-02D and ESP-WROOM-02U
	Green certification	RoHS, REACH
Test	Reliability	HTOL/HTSL/uHAST/TCT/ESD
Wi-Fi	Wi-Fi protocols	802.11 b/g/n
	Frequency range	2.4 GHz ~ 2.5 GHz (2400 MHz ~ 2483.5 MHz)
	Peripheral interface	UART/HSPI/I2C/I2S/IR Remote Control
		GPIO/PWM
	Operating voltage	2.7 V ~ 3.6 V



Categories	Items	Specifications
Hardware	Operating current	Average: 80 mA
	Minimum current delivered by power supply	500 mA
	External interface	-
	Moisture sensitivity level	Level 3
Software	Wi-Fi mode	Station/SoftAP/SoftAP + Station
	Security	WPA/WPA2
	Encryption	WEP/TKIP/AES
	Firmware upgrade	UART Download/OTA (via network)/Download and write firmware via host
	Software development	Supports Cloud Server Development/SDK for custom firmware development
	Network protocols	IPv4, TCP/UDP/HTTP/FTP
	User configuration	AT Instruction Set, Cloud Server, Android/iOS app



2. Pin Description

Figure 2-1 shows the pin distribution of the ESP-WROOM-02D.

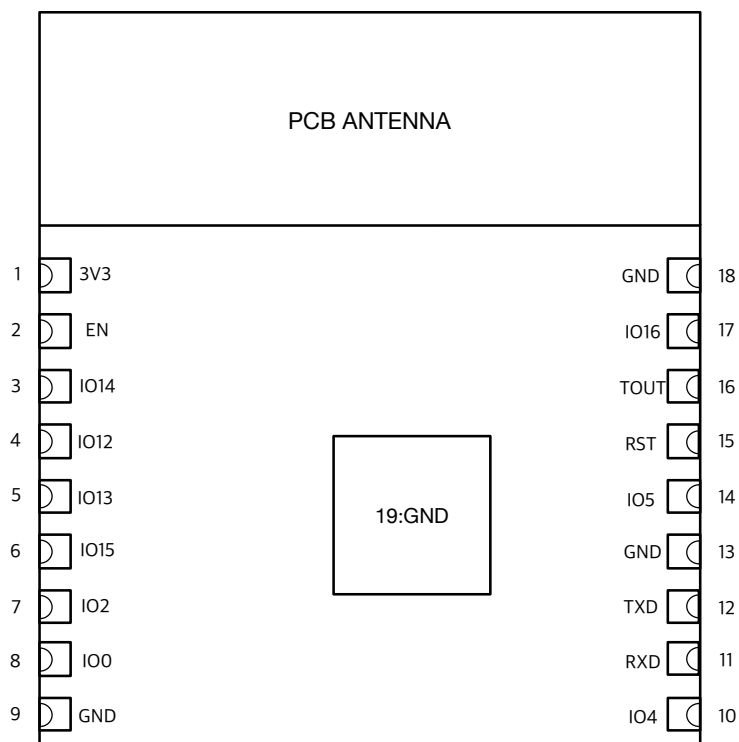

Figure 2-1. ESP-WROOM-02D Pin Layout (Top View)

Note:

The pin layout of ESP-WROOM-02U is the same with that of ESP-WROOM-02D, but it has no keepout zone for PCB antenna.

ESP-WROOM-02D and ESP-WROOM-02U have 18 pins. Please see the pin definitions in Table 2-1.

Table 2-1. ESP-WROOM-02U/ESP-WROOM-02D Pin Definitions

No.	Pin Name	Functional Description
1	3V3	3.3 V power supply (VDD) Note: It is recommended the maximum output current a power supply provides be of 500 mA or above.
2	EN	Chip enable pin. Active high.



No.	Pin Name	Functional Description
3	IO14	GPIO14; HSPI_CLK
4	IO12	GPIO12; HSPI_MISO
5	IO13	GPIO13; HSPI_MOSI; UART0_CTS
6	IO15	GPIO15; MTDO; HSPI_CS; UART0_RTS Pull down.
7	IO2	GPIO2; UART1_TXD Floating (internal pull-up) or pull up.
8	IO0	GPIO0 <ul style="list-style-type: none">• UART download: pull down.• Flash boot: floating or pull up.
9	GND	GND
10	IO4	GPIO4
11	RXD	UART0_RXD, receive end in UART download; GPIO3
12	TXD	UART0_TXD, transmit end in UART download, floating or pull up; GPIO1
13	GND	GND
14	IO5	GPIO5
15	RST	Reset
16	TOUT	It can be used to test the power-supply voltage of VDD3P3 (Pin3 and Pin4) and the input power voltage of TOUT (Pin6). These two functions cannot be used simultaneously.
17	IO16	GPIO16; used for Deep-sleep wake-up when connected to RST pin.
18	GND	GND



3. Functional Description

3.1. CPU

The ESP8266EX integrates a Tensilica L106 32-bit RISC processor, which achieves extra-low power consumption and reaches a maximum clock speed of 160 MHz. The Real-Time Operating System (RTOS) and Wi-Fi stack allow 80% of the processing power to be available for user application programming and development. The CPU includes the interfaces as below:

- Programmable RAM/ROM interfaces (iBus), which can be connected with memory controller, and can also be used to visit flash.
- Data RAM interface (dBus), which can be connected with memory controller.
- AHB interface which can be used to visit the register.

3.2. Memory

3.2.1. Internal SRAM and ROM

ESP8266EX Wi-Fi SoC integrates the memory controller and memory units including ROM and SRAM. MCU can access the memory units through iBus, dBus, and AHB interfaces. All memory units can be accessed upon request. A memory arbiter determines the running sequence in the arrival order of requests.

According to our current version of SDK, the SRAM space available to users is assigned as follows:

- RAM size < 50 kB, that is, when ESP8266EX is working in Station mode and connects to the router, available space in the Heap + Data sector is around 50 kB.
- There is no programmable ROM in ESP8266EX, therefore, the user program must be stored in an external SPI flash.

3.2.2. SPI Flash

ESP8266EX supports SPI flash. Theoretically speaking, ESP8266EX can support an up-to-16-MB SPI flash.

ESP-WROOM-02D and ESP-WROOM-02U currently integrate a 2-MB SPI flash. ESP-WROOM-02U supports these SPI modes: Standard SPI, DIO (Dual I/O), DOUT (Dual Output), QIO (Quad I/O) and QOUT (Quad Output).



3.3. Crystal Oscillator

ESP-WROOM-02U and ESP-WROOM-02D use a 26-MHz crystal oscillator. The accuracy of the crystal oscillator should be ± 10 PPM.

When using the download tool, please select the right type of crystal oscillator. In circuit design, capacitors C1 and C2 which connect to the earth are added to the input and output terminals of the crystal oscillator respectively. The values of the two capacitors can be flexible, ranging from 6 pF to 22 pF, however, the specific capacitive values depend on further testing of, and adjustment to, the overall performance of the whole circuit. Normally, the capacitive values of C1 and C2 are within 10 pF for the 26-MHz crystal oscillator.

3.4. Interface Description

Table 3-1. Interface Description

Interface	Pin	Functional Description
HSPI	IO12 (MISO), IO13 (MOSI), IO14 (CLK), IO15 (CS)	Connects to SPI Flash, display screen, and MCU.
PWM	IO12 (R), IO15 (G), IO13 (B)	Currently the PWM interface has four channels, but users can extend it to eight channels. PWM interface can realize the control of LED lights, buzzers, relays, electronic machines, etc.
IR	IO14 (IR_T), IO5 (IR_R)	The functionality of the infrared remote control interface can be realized via software programming. The interface uses NEC coding, modulation, and demodulation. The frequency of the modulated carrier signal is 38 kHz.
ADC	TOUT	Tests the power supply voltage of VDD3P3 (Pin3 and Pin4) and the input power voltage of TOUT (Pin6). However, these two functions cannot be used simultaneously. This interface is typically used in sensors.
I2C	IO14 (SCL), IO2 (SDA)	Connects to external sensors and display screens, etc.
UART	UART0: TXD (U0TXD), RXD (U0RXD), IO15 (RTS), IO13 (CTS) UART1: IO2 (TXD)	Communicates with the UART device. Downloading: U0TXD + U0RXD or GPIO2 + U0RXD Communicating: (UART0): U0TXD, U0RXD, MTDO (U0RTS), MTCK (U0CTS) Debugging: UART1_TXD (GPIO2) can be used to print debugging information. By default, UART0 will output some printed information when you power on ESP8266EX. If this issue influences some specific applications, users can exchange the inner pins of UART when initializing ESP8266EX, that is, exchange U0TXD and U0RXD with U0RTS and U0CTS. Users can connect MTDO and MTCK to the serial port of the external MCU to realize the communication.



Interface	Pin	Functional Description
I2S	I2S input: IO12 (I2SI_DATA) ; IO13 (I2SI_BCK); IO14 (I2SI_WS);	Collects, processes and transmits audio data.
	I2S output: IO15 (I2SO_BCK); IO3 (I2SO_DATA); IO2 (I2SO_WS).	



4. Electrical Characteristics

Note:

Unless otherwise specified, measurements are based on $V_{DD} = 3.3\text{ V}$, $T_A = 25\text{ }^\circ\text{C}$.

4.1. Electrical Characteristics

Table 4-1. Electrical Characteristics

Parameter	Symbol	Min	Typ	Max	Unit
Operating temperature	-	-40	20	85	$^\circ\text{C}$
Maximum soldering temperature (Condition: IPC/JEDEC J-STD-020)	-	-	-	260	$^\circ\text{C}$
Supply voltage	VDD	2.7	3.3	3.6	V
Input logic level low	V_{IL}	-0.3	-	0.25 VDD	V
Input logic level high	V_{IH}	0.75 VDD	-	VDD + 0.3	V
Output logic level low	V_{OL}	-	-	0.1 VDD	V
Output logic level high	V_{OH}	0.8 VDD	-	-	V

4.2. Wi-Fi Radio

Table 4-2. Wi-Fi Radio Characteristics

Description	Min	Typ	Max	Unit
Input frequency	2412	-	2483.5	MHz
Input reflection	-	-	-10	dB
Output Impedance	-	*	-	Ω
Output Power				
PA output power at 72.2 Mbps	13	14	15	dBm
PA output power in 11b mode	19.5	20	20.5	dBm
Sensitivity				
DSSS, 1 Mbps	-	-98	-	dBm
CCK, 11 Mbps	-	-91	-	dBm



Description	Min	Typ	Max	Unit
6 Mbps (1/2 BPSK)	-	-93	-	dBm
54 Mbps (3/4 64-QAM)	-	-75	-	dBm
HT20, MCS7 (65 Mbps, 72.2 Mbps)	-	-72	-	dBm
Adjacent channel rejection				
OFDM, 6 Mbps	-	37	-	dB
OFDM, 54 Mbps	-	21	-	dB
HT20, MCS0	-	37	-	dB
HT20, MCS7	-	20	-	dB

Note:

For the module that uses an IPEX antenna, the output impedance is 50 Ω .

4.3. Power Consumption

The following power consumption data were obtained from the tests with a 3.3 V power supply and a voltage stabilizer, in 25 °C ambient temperature. All data are based on 50% duty cycle in continuous transmission mode.

Table 4-3. Power Consumption

Modes	Min	Typ	Max	Unit
Tx 802.11 b, CCK 11 Mbps, P _{OUT} = +17 dBm	-	170	-	mA
Tx 802.11 g, OFDM 54 Mbps, P _{OUT} = +15 dBm	-	140	-	mA
Tx 802.11 n, MCS7, P _{OUT} = +13 dBm	-	120	-	mA
Rx 802.11 b, 1024 bytes packet length, -80 dBm	-	50	-	mA
Rx 802.11 g, 1024 bytes packet length, -70 dBm	-	56	-	mA
Rx 802.11 n, 1024 bytes packet length, -65 dBm	-	56	-	mA
Modem-sleep ^①	-	15	-	mA
Light-sleep ^②	-	0.9	-	mA
Deep-sleep ^③	-	20	-	μ A
Power Off	-	0.5	-	μ A

**Notes:**

- ① **Modem-sleep** is used when such applications as PWM or I2S require the CPU to be working. In cases where Wi-Fi connectivity is maintained and data transmission is not required, the Wi-Fi Modem circuit can be shut down to save power, according to 802.11 standards (such as U-APSD). For example, in DTIM3, when ESP8266EX sleeps for 300 ms and wakes up for 3 ms to receive Beacon packages from AP, the overall average current consumption is about 15 mA.
- ② **Light-sleep** is used for applications whose CPU may be suspended, such as Wi-Fi switch. In cases where Wi-Fi connectivity is maintained and data transmission is not required, the Wi-Fi Modem circuit and CPU can be shut down to save power, according to 802.11 standards (such as U-APSD). For example, in DTIM3, when ESP8266EX sleeps for 300 ms and wakes up for 3 ms to receive Beacon packages from AP, the overall average current consumption is about 0.9 mA.
- ③ **Deep-sleep** is for applications that do not require Wi-Fi connectivity but only transmit data over long time lags, e.g., a temperature sensor that measures temperature every 100s. For example, when ESP8266EX sleeps for 300 s then wakes up to connect to AP (taking about 0.3 ~ 1 s), the overall average current consumption is far less than 1 mA. The current consumption of 20 μ A was obtained at the voltage of 2.5 V.

4.4. Reflow Profile

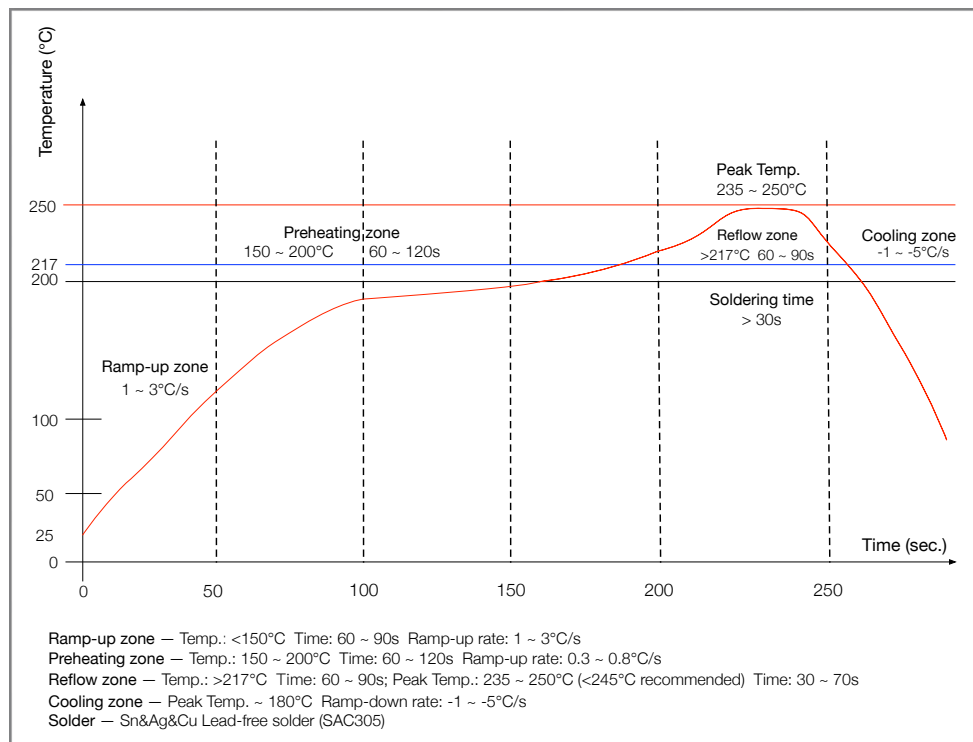

Figure 4-1. ESP-WROOM-02D/ESP-WROOM-02U Reflow Profile

**Note:**

Solder the module in a single reflow. If the PCBA requires multiple reflows, place the module on the PCB during the final reflow.

4.5. Electrostatic Discharge

Table 4-4. Electrostatic Discharge Parameters

Name	Symbol	Reference	Level	Max	Unit
Electrostatic Discharge (Human - Body Model)	V _{ESD} (HBM)	Temperature: 23 ± 5 °C Based on ANSI/ESDA/JEDEC JS - 001 - 2014	2	2000	V
Electrostatic Discharge (Charged - Device Model)	V _{ESD} (CDM)	Temperature: 23 ± 5 °C Based on JEDEC EIA/JESD22 - C101F	C2	500	



5.

Schematics

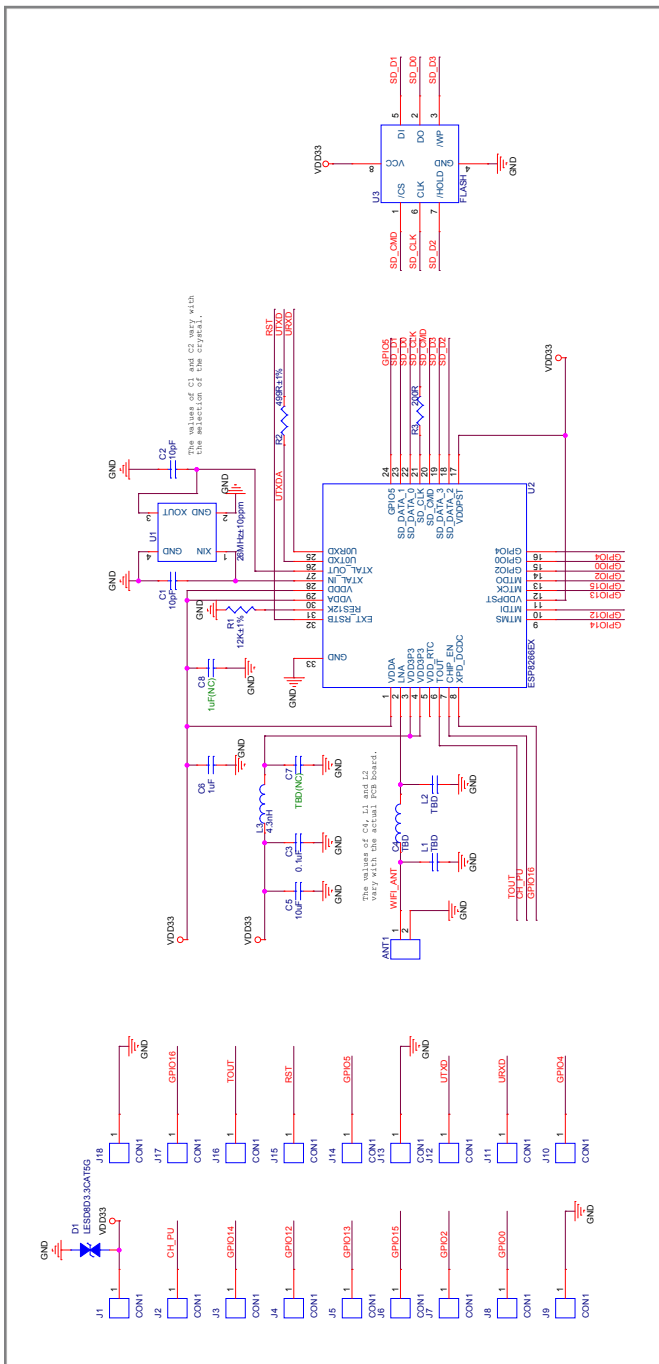

Figure 5-1. ESP-WROOM-02D Schematics

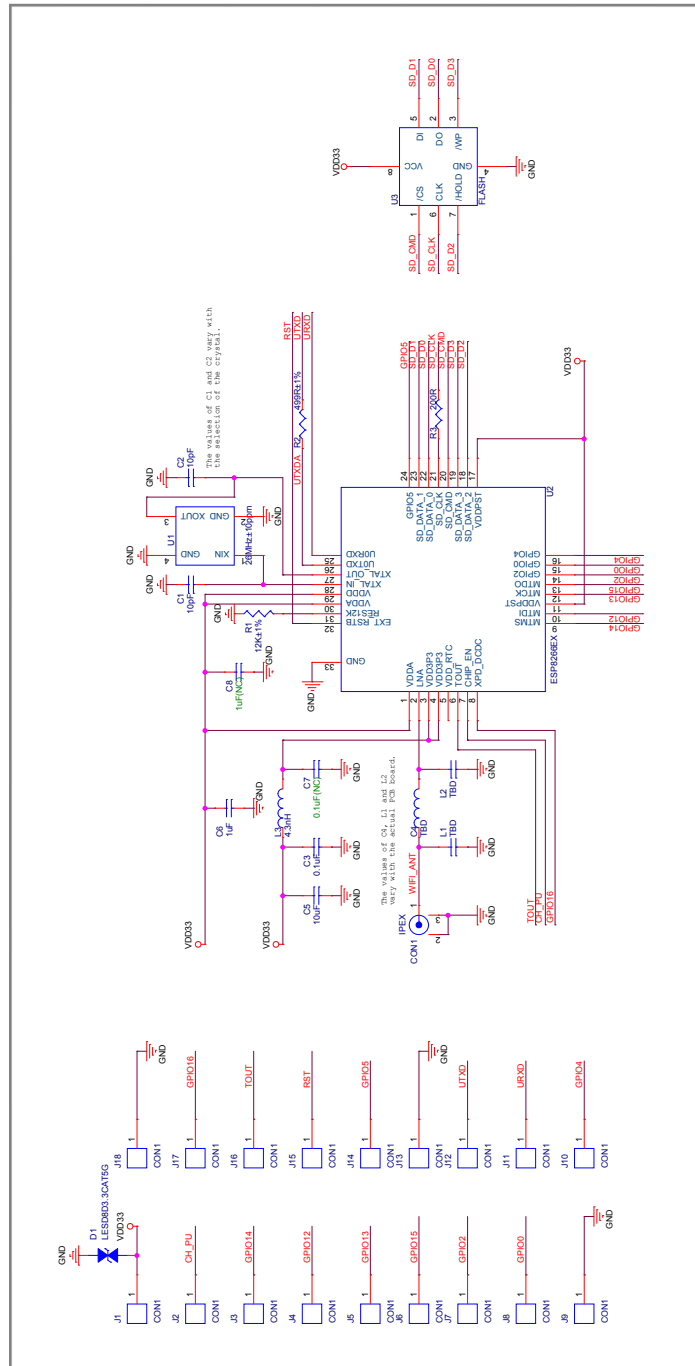

Figure 5-2. ESP-WROOM-02U Schematics



6. Peripheral Schematics

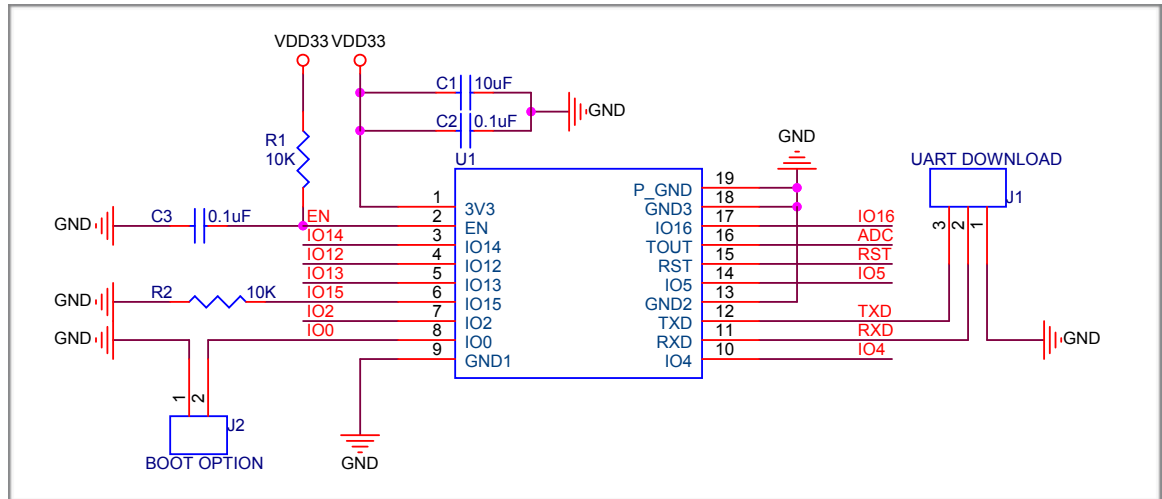

Figure 6-1. ESP-WROOM-02D/ESP-WROOM-02U Peripheral Schematics

Note:

1. Soldering Pad 19 to the Ground of the base board is not necessary for a satisfactory thermal performance. If users do want to solder it, they need to ensure that the correct quantity of soldering paste is applied.
2. To ensure the power supply to the ESP8266EX chip during the power-up, it is advised to add an RC delay circuit at the EN pin. The recommended setting for the RC delay circuit is usually $R = 10\text{ k}\Omega$ and $C = 0.1\text{ }\mu\text{F}$. However, specific parameters should be adjusted based on the power-up timing of the module and the power-up and reset timing of the ESP8266 chip. For ESP8266EX's Power-up and Reset Timing Diagram, please refer to Electrical Characteristics in [ESP8266EX Datasheet](#).
3. To improve module's anti-interference capability, it is advised to reserve an RC delay circuit at the RST pin. The recommended setting for the RC delay circuit is usually $R = 10\text{ k}\Omega$ and $C = 0.1\text{ }\mu\text{F}$.



7.

Dimensions

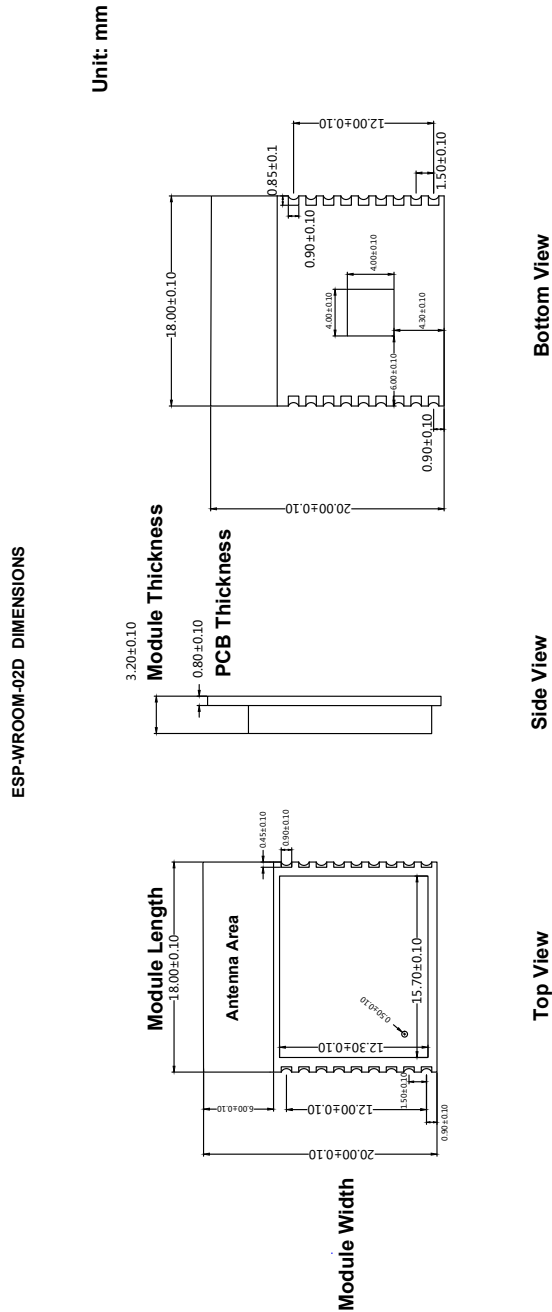

Figure 7-1. ESP-WROOM-02D Dimensions

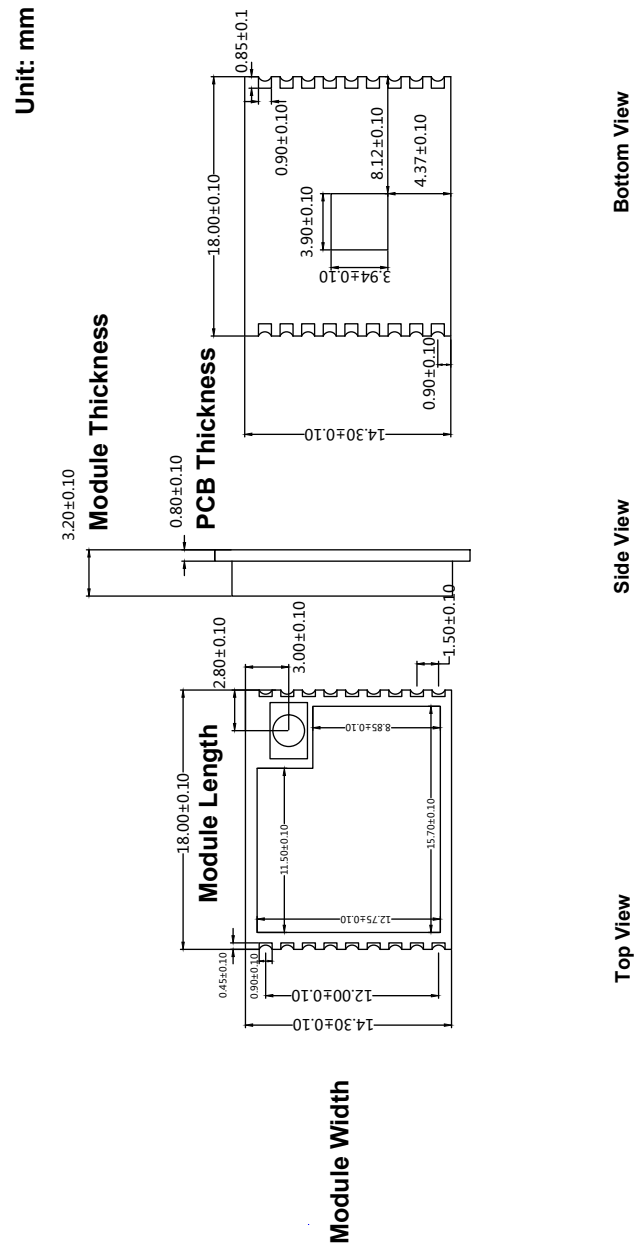

Figure 7-2. ESP-WROOM-02U Dimensions



9. U.FL Connector Dimensions

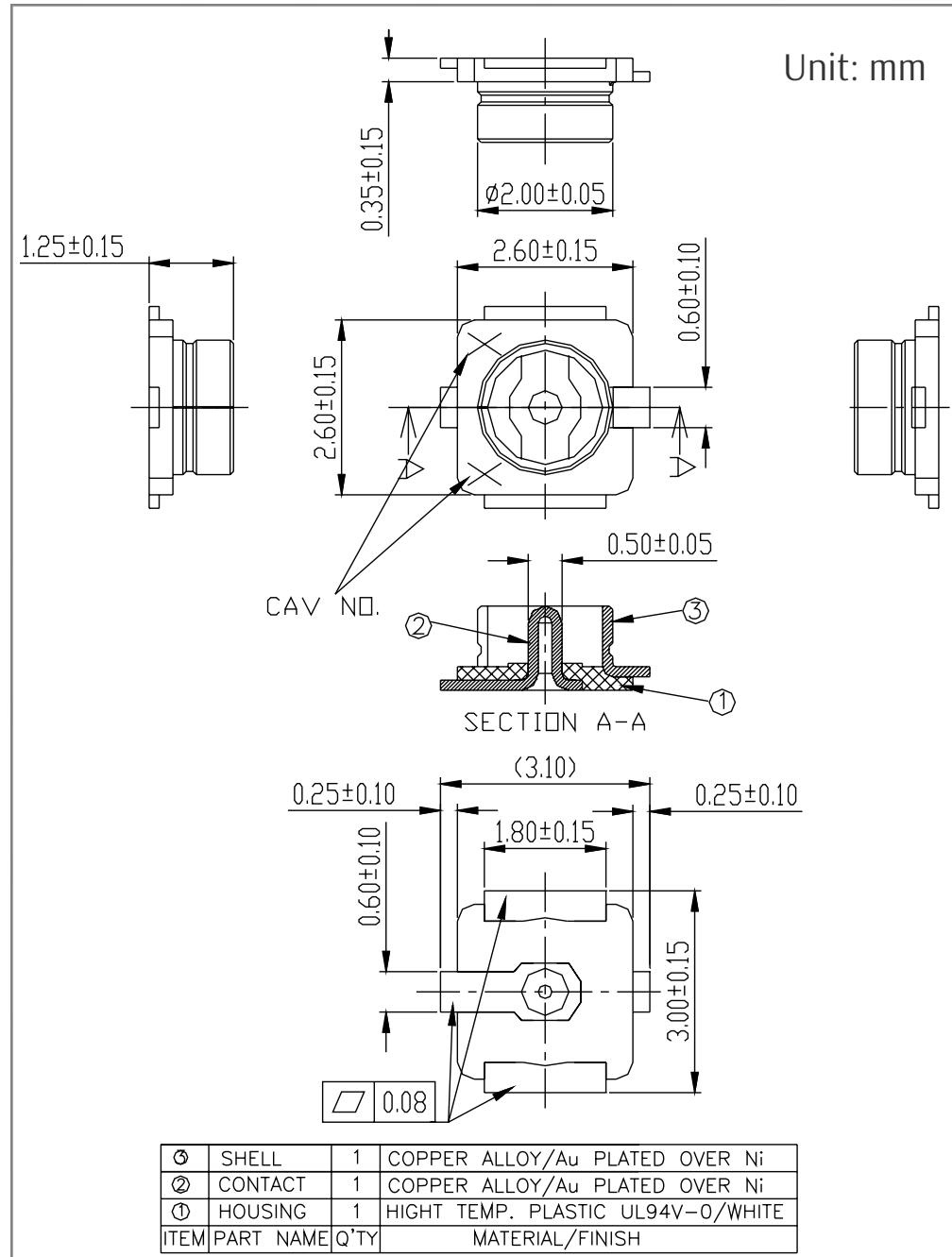

Figure 8-1. Dimensions of ESP-WROOM-02U's U.FL Connector



10. Product Handling

10.1. Storage Conditions

The products sealed in moisture barrier bags (MBB) should be stored in a non-condensing atmospheric environment of $< 40\text{ }^{\circ}\text{C}$ and 90%RH. The module is rated at the moisture sensitivity level (MSL) of 3.

After unpacking, the module must be soldered within 168 hours with the factory conditions $25 \pm 5\text{ }^{\circ}\text{C}$ and 60%RH. If the above conditions are not met, the module needs to be baked.

10.2. Electrostatic Discharge (ESD)

- Human body model (HBM): $\pm 2000\text{ V}$
- Charged-device model (CDM): $\pm 500\text{ V}$

10.3. Ultrasonic Vibration

Avoid exposing Espressif modules to vibration from ultrasonic equipment, such as ultrasonic welders or ultrasonic cleaners. This vibration may induce resonance in the in-module crystal and lead to its malfunction or even failure. As a consequence, **the module may stop working or its performance may deteriorate.**



A. Appendix—Learning Resources

A.1. Must-Read Documents

- [ESP-AT Instruction User Guide](#)
Description: This document provides users with detailed information on what is ESP-AT, how to connect hardware, and how to download and flash AT firmware.
- [ESP8266 SDK Getting Started Guide](#)
Description: This document describes how to get started with ESP8266_RTOS_SDK, which is the official development framework for the ESP8266EX chip.
- [ESP8266 Pin List](#)
Description: This link directs you to a list containing the type and function of every ESP8266 pin.
- [ESP8266 Hardware Design Guideline](#)
Description: This document provides a technical description of the ESP8266 series of products, including ESP8266EX, ESP-LAUNCHER and ESP-WROOM.
- [ESP8266 Technical Reference](#)
Description: This document provides an introduction to the interfaces integrated on ESP8266. Functional overview, parameter configuration, function description, application demos and other pieces of information are included.
- [ESP8266 Hardware Resources](#)
Description: This zip package includes manufacturing BOMs, schematics and PCB layouts of ESP8266 boards and modules.
- [ESP-WROOM-02 PCB Design and Module Placement Guide](#)
Description: The ESP-WROOM-02U module is designed to be soldered to a host PCB. This document compares six different placements of the antenna on a host board and provides notes on designing PCB.
- [ESP8266 AT User Guide](#)
Description: This Get Started guide provides users with detailed information on what is ESP-AT, how to connect hardware, and how to download and flash AT firmware.
- [FAQ](#)



A.2. Must-Have Resources

- [ESP8266 SDKs](#)

Description: This website page provides links to the latest version of ESP8266 SDK and the older ones.

- [ESP8266 Tools](#)

Description: This website page provides links to the ESP8266 flash download tools and ESP8266 performance evaluation tools.

- [ESP8266 App](#)
- [ESP8266 Certification and Test Guide](#)
- [ESP8266 BBS](#)
- [ESP8266 Resources](#)



Espressif IoT Team
www.espressif.com

Disclaimer and Copyright Notice

Information in this document, including URL references, is subject to change without notice.

THIS DOCUMENT IS PROVIDED AS IS WITH NO WARRANTIES WHATSOEVER, INCLUDING ANY WARRANTY OF MERCHANTABILITY, NON-INFRINGEMENT, FITNESS FOR ANY PARTICULAR PURPOSE, OR ANY WARRANTY OTHERWISE ARISING OUT OF ANY PROPOSAL, SPECIFICATION OR SAMPLE.

All liability, including liability for infringement of any proprietary rights, relating to use of information in this document is disclaimed. No licenses express or implied, by estoppel or otherwise, to any intellectual property rights are granted herein.

The Wi-Fi Alliance Member logo is a trademark of the Wi-Fi Alliance. The Bluetooth logo is a registered trademark of Bluetooth SIG.

All trade names, trademarks and registered trademarks mentioned in this document are property of their respective owners, and are hereby acknowledged.

Copyright © 2023 Espressif Inc. All rights reserved.

Looking for pricing, stock, or lifecycle information?

Click below to explore more details on WIN SOURCE:

 [View ESP-WROOM-02U-N4 on WIN SOURCE](#)

 [Espressif Information](#)

Optimize Your Supply Chain with WIN SOURCE Solutions

-  Global Sourcing Solution
-  Obsolete Management
-  Cost Control Management
-  Shortage Management
-  Alternative Solution
-  Excess Inventory Management