



**THE DATASHEET OF  
DF1B-2022PCFB**



## DF1B Series

# 2.5mm Pitch Connector for Discrete Wire Connection (UL/CSA Standard Certified Product)

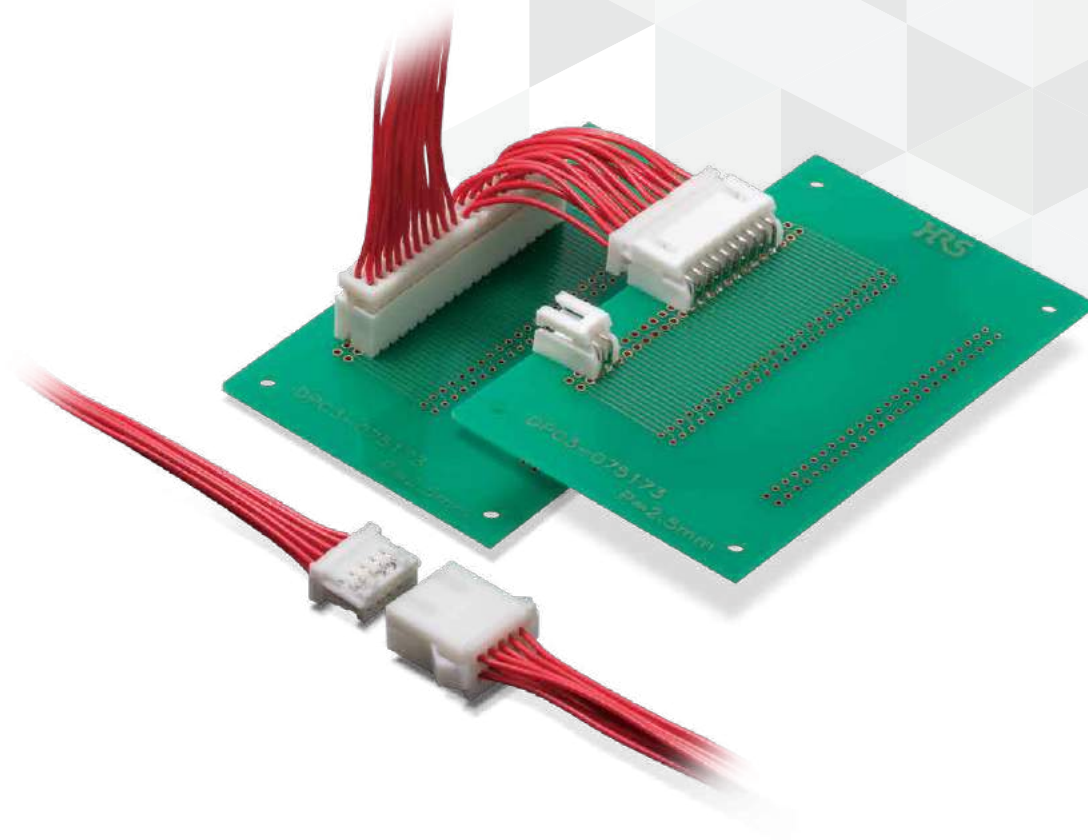
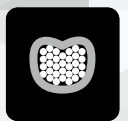

Jun.1.2024 Copyright 2024 HIROSE ELECTRIC CO., LTD. All Rights Reserved.



# Features

---

## 1. Wide Variety

Each of the "wire-to-board" and "in-line" types has single and double row variations, and both tin and gold plating are available as standard. (Refer to the applicable combination diagram on the next page.)

## Applications

Business equipment including copy machines and printers.

## Product Specifications

|                           |            |        |              |        |        |          |                                   |              |
|---------------------------|------------|--------|--------------|--------|--------|----------|-----------------------------------|--------------|
| Rated Current<br>(Note 1) | No of Pos. | 20 AWG | 22 to 24 AWG | 26 AWG | 28 AWG | 30 AWG   | Operating Temperature (Note 2)    | -35 to +85°C |
|                           | 2          | 5A/pin | 3A/pin       | 2A/pin | 1A/pin | 0.5A/pin | Operating Humidity Range (Note 3) | 40 to 80%    |
|                           | 3 to 40    | 3A/pin | 3A/pin       | 2A/pin | 1A/pin | 0.5A/pin | Storage Temperature Range (Note4) | -10 to +60°C |
| Rated Voltage             | 250V AC/DC |        |              |        |        |          | Storage Humidity Range (Note 4)   | 40 to 70%    |

|                                 |           |           |          |
|---------------------------------|-----------|-----------|----------|
| UL, CSA Current Rating (Note 1) | 20-22 AWG | 24-28 AWG | 30 AWG   |
|                                 | 3A/pin    | 1A/pin    | 0.5A/pin |
| UL, CSA Voltage Rating          | 30V AC/DC |           |          |

UL CSA Safety File No. UL : E52653/CSA : LR95109

Note 1 : The rated current varies based on cable size used. The current rating of only the header is 3A.

Note 2 : Includes temperature rise caused by current flow.

Note 3 : Please use without condensation.

Note 4 : Applicable to unused items in packaged state.

Note 5 : Information contained in this catalog represents general requirements for this Series. Contact us for the drawings and specifications for a specific part number shown.

| Item                              | Specification   | Condition  |
|-----------------------------------|---|--|
| Insulation Resistance             | 1000M $\Omega$ Min  | 500V DC  |
| Withstanding Voltage              | No flashover or insulation breakdown.   | 650V AC for 1 min.   |
| Contact Resistance                | 30m $\Omega$ Max  | 100mA  |
| Single Insertion/Extraction Force | 0.44N(45gf) Min., 4.4N(450gf) Max.  | Measure at the square steel pin of 0.635 $\pm$ 0.002mm   |
| Vibration                         | No electrical discontinuity of 1 $\mu$ s or more                                  | Frequency :<br>10 to 55Hz, single amplitude of 0.75mm<br>2 hours in each of the 3 directions.                                |
| Humidity (Steady State)           | Contact resistance:30m $\Omega$ Max.<br>Insulation resistance:1000M $\Omega$ Min. | 96 hours at temperature of 40 $\pm$ 2°C and humidity of 90% to 95%   |
| Temperature Cycle                 | Contact resistance:30m $\Omega$ Max.<br>Insulation resistance:1000M $\Omega$ Min. | (-55°C : 30 minutes $\rightarrow$ 5 to 35°C : 10 minutes<br>85°C : 30 minutes $\rightarrow$ 5 to 35°C : 10 minutes) 5 cycles |
| Mating Durability                 | Contact resistance:30m $\Omega$ Max.  | Tin plating : 30 cycles<br>Gold plating : 50 cycles  |
| Resistance to Soldering Heat      | No deformation of components affecting performance.                               | Flow : 260°C for 5 seconds<br>Manual soldering : 300°C for 3 seconds   |

## Materials / Finish

| Product                           | Part      | Material        | Finish                    | Remarks | RoHS2 |
|-----------------------------------|-----------|-----------------|---------------------------|---------|-------|
| Socket                            | Insulator | Polyamide       | White                     | UL94V-0 | Yes   |
| Crimping Contact for Socket       | Contact   | Phosphor Copper | Tin Plated or Gold Plated | -       |       |
| Pin Header                        | Insulator | Polyamide       | White                     | UL94V-0 |       |
|                                   | Contact   | Brass           | Tin Plated or Gold Plated | -       |       |
| In-line Plug                      | Insulator | Polyamide       | White                     | UL94V-0 |       |
| Crimping Contact for In-line Plug | Contact   | Phosphor Copper | Tin Plated or Gold Plated | -       |       |

## Product Number Structure

Refer to the chart below when determining the product specifications from the product number. Please select from the product numbers listed in this catalog when placing orders.

### Connector

#### DF1B # - # S - 2.5 RC

① ② ③ ④ ⑤ ⑥

|                |  |                  |  |
|----------------|--|------------------|--|
| ① Series Name  | DF1B   | ④ Connector Type | S : Single Row Socket<br>DS : Double Row Socket<br>P : Single Row Pin Header<br>DP : Double Row Pin Header<br>ES : Single Row In-line Socket<br>DES : Double Row In-line Socket<br>EP : Single Row In-line Plug<br>DEP : Double Row In-line Plug |
| ② Style Symbol | Blank : Standard type<br>A : In-line Plug (Simple Lock Type)<br>Z : Pin Header (Standard Type, Tin Plated) | ⑤ Contact Pitch  | 2.5mm  |
| ③ No. of Pos.  | Single Row : 2 to 14<br>Double Row : 4 to 40   | ⑥ Contact Type   | RC : IDC/Crimping Socket (Note)<br>DSA : Straight Through Hole<br>DS : Right Angle Through Hole  |

### Crimping Contact

#### DF1B - 2428 SCF A

① ② ③

|                         |  |                |   |
|-------------------------|--|----------------|---|
| ① Applicable Cable Size | 2022 : 20 to 22 AWG<br>2428 : 24 to 28 AWG<br>30 : 30 AWG  | ③ Plating Type | Blank : Tin Plated<br>A : Gold Plated<br>B : Gold Plated (Note) |
| ② Packaging Type        | SCF : Socket Contact/Reel<br>SC : Socket Contact/Bag<br>PCF : Plug Contact/Reel<br>PC : Plug Contact/Bag |                |   |

Note : Socket contacts have an "A" at the end of the product name. Plug contacts have a "B" at the end of the product name. The product numbers of gold plated plug contacts for 24 to 28 AWG cable are DF1-PD2428SCFB(Reel) and DF1-PD2428SCB(Bag).

## Applicable Combination

### ● Single Row Type

Socket (Cable Side)  
DF1B-#S-2.5R

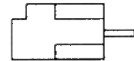

Straight Through Hole Type  
Pin Header  
DF1B(Z)-#P-2.5DSA



Right Angle Through Hole Type  
Pin Header  
DF1BZ-#P-2.5DS



Panel Mount Type  
In-line Plug (Cable Side)  
DF1BA-#EP-2.5RC

### ● Double Row Type

Socket (Cable Side)  
DF1B-#DS-2.5RC



Straight Through Hole Type  
Pin Header  
DF1BZ-#DP-2.5DSA



Right Angle Through Hole Type  
Pin Header  
DF1BZ-#DP-2.5DS



Panel Mount Type  
In-line Plug (Cable Side)  
DF1BA-#DEP-2.5RC

## 《In-line/ Positive Lock Type》

### ● Single Row Type

Socket (Cable Side)  
DF1B-#ES-2.5RC



In-line Plug (Cable Side)  
DF1B-#EP-2.5RC

### ● Double Row Type

Socket (Cable Side)  
DF1B-#DES-2.5RC

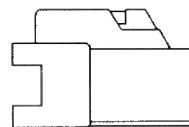

In-line Plug (Cable Side)  
DF1B-#DEP-2.5RC

## Single Row Socket



Shown with Contacts Inserted



Note : The 2pos. connector differs from the above figure and has a single center projection to prevent mis-insertion. For 3-6pos. there are two projections at both ends, and for 7-20pos. there are three projections.

Unit : mm

| Part No.      | HRS No.          | No. of Pos. | A    | B    | Purchase Unit  |
|---------------|------------------|-------------|------|------|----------------|
| DF1B-2S-2.5R  | CL0541-0200-6-00 | 2           | 5.0  | 2.5  | 100pcs per bag |
| DF1B-3S-2.5R  | CL0541-0201-9-00 | 3           | 7.5  | 5.0  |                |
| DF1B-4S-2.5R  | CL0541-0202-1-00 | 4           | 10.0 | 7.5  |                |
| DF1B-5S-2.5R  | CL0541-0203-4-00 | 5           | 12.5 | 10.0 |                |
| DF1B-6S-2.5R  | CL0541-0204-7-00 | 6           | 15.0 | 12.5 |                |
| DF1B-7S-2.5R  | CL0541-0205-0-00 | 7           | 17.5 | 15.0 |                |
| DF1B-8S-2.5R  | CL0541-0206-2-00 | 8           | 20.0 | 17.5 |                |
| DF1B-9S-2.5R  | CL0541-0207-5-00 | 9           | 22.5 | 20.0 |                |
| DF1B-10S-2.5R | CL0541-0208-8-00 | 10          | 25.0 | 22.5 |                |
| DF1B-12S-2.5R | CL0541-0210-0-00 | 12          | 30.0 | 27.5 |                |
| DF1B-14S-2.5R | CL0541-0212-5-00 | 14          | 35.0 | 32.5 |                |

## Double Row Socket



Shown with Contacts Inserted



Note : The 4pos. connector differs from the above figure and has a single center projection to prevent mis-insertion.

Unit : mm

| Part No.        | HRS No.          | No. of Pos. | A    | B    | Purchase Unit     |
|-----------------|------------------|-------------|------|------|-------------------|
| DF1B-4DS-2.5RC  | CL0541-0648-0-00 | 4           | 7.5  | 2.5  | 100pcs<br>per bag |
| DF1B-6DS-2.5RC  | CL0541-0649-3-00 | 6           | 10.0 | 5.0  |                   |
| DF1B-8DS-2.5RC  | CL0541-0650-2-00 | 8           | 12.5 | 7.5  |                   |
| DF1B-10DS-2.5RC | CL0541-0600-4-00 | 10          | 15.0 | 10.0 |                   |
| DF1B-12DS-2.5RC | CL0541-0601-7-00 | 12          | 17.5 | 12.5 |                   |
| DF1B-14DS-2.5RC | CL0541-0602-0-00 | 14          | 20.0 | 15.0 |                   |
| DF1B-16DS-2.5RC | CL0541-0603-2-00 | 16          | 22.5 | 17.5 |                   |
| DF1B-18DS-2.5RC | CL0541-0604-5-00 | 18          | 25.0 | 20.0 |                   |
| DF1B-20DS-2.5RC | CL0541-0605-8-00 | 20          | 27.5 | 22.5 |                   |
| DF1B-22DS-2.5RC | CL0541-0606-0-00 | 22          | 30.0 | 25.0 |                   |
| DF1B-24DS-2.5RC | CL0541-0607-3-00 | 24          | 32.5 | 27.5 |                   |
| DF1B-26DS-2.5RC | CL0541-0608-6-00 | 26          | 35.0 | 30.0 |                   |
| DF1B-28DS-2.5RC | CL0541-0609-9-00 | 28          | 37.5 | 32.5 |                   |
| DF1B-30DS-2.5RC | CL0541-0610-8-00 | 30          | 40.0 | 35.0 |                   |
| DF1B-34DS-2.5RC | CL0541-0612-3-00 | 34          | 45.0 | 40.0 |                   |
| DF1B-36DS-2.5RC | CL0541-0613-6-00 | 36          | 47.5 | 42.5 |                   |
| DF1B-40DS-2.5RC | CL0541-0615-1-00 | 40          | 52.5 | 47.5 |                   |

## Single Row Straight Pin Header



● Board Through-hole Diameter :  $\phi 1.1^{+0.1}_0$

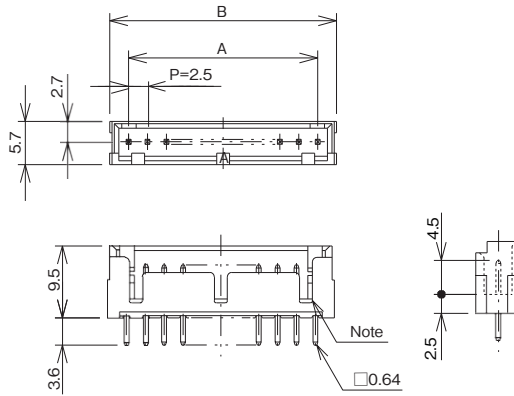

Note : The 2 and 3pos. connectors differ from the above figure and have a single center indentation to prevent mis-insertion. For 4-6pos. there are two indentations at both ends, and for 7-20pos. there are three indentations.

### Recommended PCB Layout (t=1.6±0.1mm)



Unit : mm

| Tin Plated       |                  | Gold Plated         |                  | No. of Pos. | A    | B    | Purchase Unit  |
|------------------|------------------|---------------------|------------------|-------------|------|------|----------------|
| Part No.         | HRS No.          | Part No.            | HRS No.          |             |      |      |                |
| DF1BZ-2P-2.5DSA  | CL0541-2000-8-00 | DF1B-2P-2.5DSA(01)  | CL0541-0225-7-01 | 2           | 2.5  | 7.5  | 100pcs per bag |
| DF1BZ-3P-2.5DSA  | CL0541-2001-0-00 | DF1B-3P-2.5DSA(01)  | CL0541-0226-0-01 | 3           | 5.0  | 10.0 |                |
| DF1BZ-4P-2.5DSA  | CL0541-2002-3-00 | DF1B-4P-2.5DSA(01)  | CL0541-0227-2-01 | 4           | 7.5  | 12.5 |                |
| DF1BZ-5P-2.5DSA  | CL0541-2003-6-00 | DF1B-5P-2.5DSA(01)  | CL0541-0228-5-01 | 5           | 10.0 | 15.0 |                |
| DF1BZ-6P-2.5DSA  | CL0541-2004-9-00 | DF1B-6P-2.5DSA(01)  | CL0541-0229-8-01 | 6           | 12.5 | 17.5 |                |
| DF1BZ-7P-2.5DSA  | CL0541-2005-1-00 | DF1B-7P-2.5DSA(01)  | CL0541-0230-7-01 | 7           | 15.0 | 20.0 |                |
| DF1BZ-8P-2.5DSA  | CL0541-2006-4-00 | DF1B-8P-2.5DSA(01)  | CL0541-0231-0-01 | 8           | 17.5 | 22.5 |                |
| DF1BZ-9P-2.5DSA  | CL0541-2007-7-00 | DF1B-9P-2.5DSA(01)  | CL0541-0232-2-01 | 9           | 20.0 | 25.0 |                |
| DF1BZ-10P-2.5DSA | CL0541-2008-0-00 | DF1B-10P-2.5DSA(01) | CL0541-0233-5-01 | 10          | 22.5 | 27.5 |                |
| DF1BZ-12P-2.5DSA | CL0541-2010-1-00 | DF1B-12P-2.5DSA(01) | CL0541-0235-0-01 | 12          | 27.5 | 32.5 |                |
| DF1BZ-14P-2.5DSA | CL0541-2012-7-00 | DF1B-14P-2.5DSA(01) | CL0541-0237-6-01 | 14          | 32.5 | 37.5 |                |

# Single Row Right Angle Pin Header



● Board Through-hole Diameter :  $\phi 1.1^{+0.1}_0$

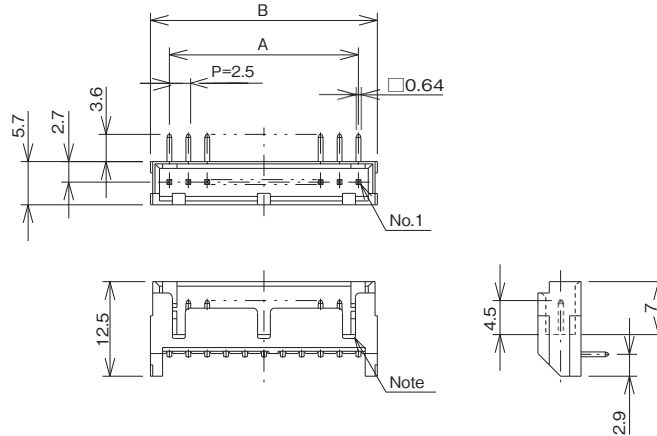

Note : The 2 and 3pos. connectors differ from the above figure and have a single center indentation to prevent mis-insertion. For 4-6pos. there are two indentations at both ends, and for 7-20pos. there are three indentations.

Recommended PCB Layout ( $t=1.6\pm 0.1\text{mm}$ )

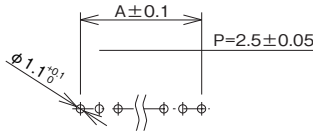

Unit : mm

| Tin Plated      |                  | Gold Plated        |                  | No. of Pos. | A    | B    | Purchase Unit  |
|-----------------|------------------|--------------------|------------------|-------------|------|------|----------------|
| Part No.        | HRS No.          | Part No.           | HRS No.          |             |      |      |                |
| DF1BZ-2P-2.5DS  | CL0541-2034-0-00 | DF1B-2P-2.5DS(01)  | CL0541-0242-6-01 | 2           | 2.5  | 7.5  | 100pcs per bag |
| DF1BZ-3P-2.5DS  | CL0541-2035-2-00 | DF1B-3P-2.5DS(01)  | CL0541-0243-9-01 | 3           | 5.0  | 10.0 |                |
| DF1BZ-4P-2.5DS  | CL0541-2036-5-00 | DF1B-4P-2.5DS(01)  | CL0541-0244-1-01 | 4           | 7.5  | 12.5 |                |
| DF1BZ-5P-2.5DS  | CL0541-2037-8-00 | DF1B-5P-2.5DS(01)  | CL0541-0245-4-01 | 5           | 10.0 | 15.0 |                |
| DF1BZ-6P-2.5DS  | CL0541-2038-0-00 | DF1B-6P-2.5DS(01)  | CL0541-0246-7-01 | 6           | 12.5 | 17.5 |                |
| DF1BZ-7P-2.5DS  | CL0541-2039-3-00 | DF1B-7P-2.5DS(01)  | CL0541-0247-0-01 | 7           | 15.0 | 20.0 |                |
| DF1BZ-8P-2.5DS  | CL0541-2040-2-00 | DF1B-8P-2.5DS(01)  | CL0541-0248-2-01 | 8           | 17.5 | 22.5 |                |
| DF1BZ-9P-2.5DS  | CL0541-2041-5-00 | -                  | -                | 9           | 20.0 | 25.0 |                |
| DF1BZ-10P-2.5DS | CL0541-2042-8-00 | DF1B-10P-2.5DS(01) | CL0541-0250-4-01 | 10          | 22.5 | 27.5 |                |
| DF1BZ-12P-2.5DS | CL0541-2044-3-00 | DF1B-12P-2.5DS(01) | CL0541-0252-0-01 | 12          | 27.5 | 32.5 |                |
| DF1BZ-14P-2.5DS | CL0541-2046-9-00 | DF1B-14P-2.5DS(01) | CL0541-0254-5-01 | 14          | 32.5 | 37.5 |                |

## Double Row Straight Pin Header



● Board Through-hole Diameter :  $\phi 1.1^{+0.1}_0$



Note : The 4 and 6pos. connectors differ from the above figure and have a single center indentation to prevent mis-insertion.

Recommended PCB Layout (t=1.6±0.1mm)



Unit : mm

| Tin Plated        |                  | Gold Plated          |                  | No. of Pos. | A    | B    | Purchase Unit  |
|-------------------|------------------|----------------------|------------------|-------------|------|------|----------------|
| Part No.          | HRS No.          | Part No.             | HRS No.          |             |      |      |                |
| DF1BZ-4DP-2.5DSA  | CL0541-2017-0-00 | DF1B-4DP-2.5DSA(01)  | CL0541-0651-5-01 | 4           | 2.5  | 7.5  | 100pcs per bag |
| DF1BZ-6DP-2.5DSA  | CL0541-2018-3-00 | DF1B-6DP-2.5DSA(01)  | CL0541-0652-8-01 | 6           | 5.0  | 10.0 |                |
| DF1BZ-8DP-2.5DSA  | CL0541-2019-6-00 | DF1B-8DP-2.5DSA(01)  | CL0541-0653-0-01 | 8           | 7.5  | 12.5 |                |
| DF1BZ-10DP-2.5DSA | CL0541-2020-5-00 | DF1B-10DP-2.5DSA(01) | CL0541-0616-4-01 | 10          | 10.0 | 15.0 |                |
| DF1BZ-12DP-2.5DSA | CL0541-2021-8-00 | DF1B-12DP-2.5DSA(01) | CL0541-0617-7-01 | 12          | 12.5 | 17.5 |                |
| DF1BZ-14DP-2.5DSA | CL0541-2022-0-00 | DF1B-14DP-2.5DSA(01) | CL0541-0618-0-01 | 14          | 15.0 | 20.0 |                |
| DF1BZ-16DP-2.5DSA | CL0541-2023-3-00 | DF1B-16DP-2.5DSA(01) | CL0541-0619-2-01 | 16          | 17.5 | 22.5 |                |
| DF1BZ-18DP-2.5DSA | CL0541-2024-6-00 | DF1B-18DP-2.5DSA(01) | CL0541-0620-1-01 | 18          | 20.0 | 25.0 |                |
| DF1BZ-20DP-2.5DSA | CL0541-2025-9-00 | DF1B-20DP-2.5DSA(01) | CL0541-0621-4-01 | 20          | 22.5 | 27.5 |                |
| DF1BZ-22DP-2.5DSA | CL0541-2026-1-00 | DF1B-22DP-2.5DSA(01) | CL0541-0622-7-01 | 22          | 25.0 | 30.0 |                |
| DF1BZ-24DP-2.5DSA | CL0541-2027-4-00 | DF1B-24DP-2.5DSA(01) | CL0541-0623-0-01 | 24          | 27.5 | 32.5 |                |
| DF1BZ-26DP-2.5DSA | CL0541-2028-7-00 | DF1B-26DP-2.5DSA(01) | CL0541-0624-2-01 | 26          | 30.0 | 35.0 |                |
| DF1BZ-28DP-2.5DSA | CL0541-2029-0-00 | DF1B-28DP-2.5DSA(01) | CL0541-0625-5-01 | 28          | 32.5 | 37.5 |                |
| DF1BZ-30DP-2.5DSA | CL0541-2030-9-00 | DF1B-30DP-2.5DSA(01) | CL0541-0626-8-01 | 30          | 35.0 | 40.0 |                |
| DF1BZ-34DP-2.5DSA | CL0541-2031-1-00 | DF1B-34DP-2.5DSA(01) | CL0541-0628-3-01 | 34          | 40.0 | 45.0 |                |
| DF1BZ-36DP-2.5DSA | CL0541-2032-4-00 | DF1B-36DP-2.5DSA(01) | CL0541-0629-6-01 | 36          | 42.5 | 47.5 |                |
| DF1BZ-40DP-2.5DSA | CL0541-2033-7-00 | DF1B-40DP-2.5DSA(01) | CL0541-0631-8-01 | 40          | 47.5 | 52.5 |                |

## Double Row Right Angle Pin Header



● Board Through-hole Diameter :  $\phi 1.1^{+0.1}_0$



Note : The 4 and 6pos. connectors differ from the above figure and have a single center indentation to prevent mis-insertion.

Recommended PCB Layout ( $t=1.6\pm 0.1\text{mm}$ )

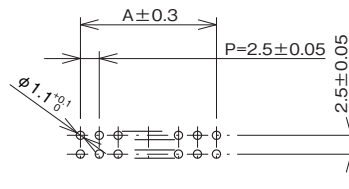

Unit : mm

| Tin Plated       |                  | Gold Plated         |                  | No. of Pos. | A    | B    | Purchase Unit  |
|------------------|------------------|---------------------|------------------|-------------|------|------|----------------|
| Part No.         | HRS No.          | Part No.            | HRS No.          |             |      |      |                |
| DF1BZ-4DP-2.5DS  | CL0541-2051-9-00 | DF1B-4DP-2.5DS(01)  | CL0541-0654-3-01 | 4           | 2.5  | 7.5  | 100pcs per bag |
| DF1BZ-6DP-2.5DS  | CL0541-2052-1-00 | DF1B-6DP-2.5DS(01)  | CL0541-0655-6-01 | 6           | 5.0  | 10.0 |                |
| DF1BZ-8DP-2.5DS  | CL0541-2053-4-00 | DF1B-8DP-2.5DS(01)  | CL0541-0656-9-01 | 8           | 7.5  | 12.5 |                |
| DF1BZ-10DP-2.5DS | CL0541-2054-7-00 | DF1B-10DP-2.5DS(01) | CL0541-0632-0-01 | 10          | 10.0 | 15.0 |                |
| DF1BZ-12DP-2.5DS | CL0541-2055-0-00 | DF1B-12DP-2.5DS(01) | CL0541-0633-3-01 | 12          | 12.5 | 17.5 |                |
| DF1BZ-14DP-2.5DS | CL0541-2056-2-00 | DF1B-14DP-2.5DS(01) | CL0541-0634-6-01 | 14          | 15.0 | 20.0 |                |
| DF1BZ-16DP-2.5DS | CL0541-2057-5-00 | DF1B-16DP-2.5DS(01) | CL0541-0635-9-01 | 16          | 17.5 | 22.5 |                |
| DF1BZ-18DP-2.5DS | CL0541-2058-8-00 | DF1B-18DP-2.5DS(01) | CL0541-0636-1-01 | 18          | 20.0 | 25.0 |                |
| DF1BZ-20DP-2.5DS | CL0541-2059-0-00 | DF1B-20DP-2.5DS(01) | CL0541-0637-4-01 | 20          | 22.5 | 27.5 |                |
| DF1BZ-22DP-2.5DS | CL0541-2060-0-00 | DF1B-22DP-2.5DS(01) | CL0541-0638-7-01 | 22          | 25.0 | 30.0 |                |
| DF1BZ-24DP-2.5DS | CL0541-2061-2-00 | DF1B-24DP-2.5DS(01) | CL0541-0639-0-01 | 24          | 27.5 | 32.5 |                |
| DF1BZ-26DP-2.5DS | CL0541-2062-5-00 | DF1B-26DP-2.5DS(01) | CL0541-0640-9-01 | 26          | 30.0 | 35.0 |                |
| DF1BZ-28DP-2.5DS | CL0541-2063-8-00 | DF1B-28DP-2.5DS(01) | CL0541-0641-1-01 | 28          | 32.5 | 37.5 |                |
| DF1BZ-30DP-2.5DS | CL0541-2064-0-00 | DF1B-30DP-2.5DS(01) | CL0541-0642-4-01 | 30          | 35.0 | 40.0 |                |
| DF1BZ-34DP-2.5DS | CL0541-2065-3-00 | DF1B-34DP-2.5DS(01) | CL0541-0644-0-01 | 34          | 40.0 | 45.0 |                |
| DF1BZ-36DP-2.5DS | CL0541-2066-6-00 | DF1B-36DP-2.5DS(01) | CL0541-0645-2-01 | 36          | 42.5 | 47.5 |                |
| DF1BZ-40DP-2.5DS | CL0541-2067-9-00 | DF1B-40DP-2.5DS(01) | CL0541-0647-8-01 | 40          | 47.5 | 52.5 |                |

## Single Row In-line Plug (Friction Lock Type)



Shown with Contacts Inserted  
 ●Applicable Socket: DF1B-#S-2.5R



Note : The 2pos. connector differs from the above figure and has a single center indentation to prevent mis-insertion. For 3-6pos. there are two indentations at both ends, and for 7-20pos. there are three indentations.

Unit : mm

| Part No.         | HRS No.          | No. of Pos. | A    | B    | Purchase Unit  |
|------------------|------------------|-------------|------|------|----------------|
| DF1BA-2EP-2.5RC  | CL0541-0700-9-00 | 2           | 2.5  | 7.1  | 100pcs per bag |
| DF1BA-3EP-2.5RC  | CL0541-0701-1-00 | 3           | 5.0  | 9.6  |                |
| DF1BA-4EP-2.5RC  | CL0541-0702-4-00 | 4           | 7.5  | 12.1 |                |
| DF1BA-5EP-2.5RC  | CL0541-0703-7-00 | 5           | 10.0 | 14.6 |                |
| DF1BA-6EP-2.5RC  | CL0541-0704-0-00 | 6           | 12.5 | 17.1 |                |
| DF1BA-7EP-2.5RC  | CL0541-0705-2-00 | 7           | 15.0 | 19.6 |                |
| DF1BA-8EP-2.5RC  | CL0541-0706-5-00 | 8           | 17.5 | 22.1 |                |
| DF1BA-9EP-2.5RC  | CL0541-0707-8-00 | 9           | 20.0 | 24.6 |                |
| DF1BA-10EP-2.5RC | CL0541-0708-0-00 | 10          | 22.5 | 27.1 |                |

## Panel Cutouts

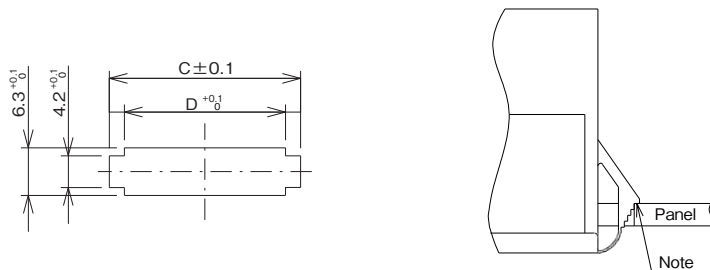

Note : Do not use a rounded surface at the panel tab portion.

Unit : mm

| Applicable Plug  | No. of Pos. | C                              |            |            | D    |
|------------------|-------------|--------------------------------|------------|------------|------|
|                  |             | Panel Board Thickness (Note 1) |            |            |      |
|                  |             | 0.5 to 1.2                     | 1.3 to 1.6 | 1.7 to 2.0 |      |
| DF1BA-2EP-2.5RC  | 2           | 11.2                           | 11.9       | 12.6       | 7.3  |
| DF1BA-3EP-2.5RC  | 3           | 13.7                           | 14.4       | 15.1       | 9.8  |
| DF1BA-4EP-2.5RC  | 4           | 16.2                           | 16.9       | 17.6       | 12.3 |
| DF1BA-5EP-2.5RC  | 5           | 18.7                           | 19.4       | 20.1       | 14.8 |
| DF1BA-6EP-2.5RC  | 6           | 21.2                           | 21.9       | 22.6       | 17.3 |
| DF1BA-7EP-2.5RC  | 7           | 23.7                           | 24.4       | 25.1       | 19.8 |
| DF1BA-8EP-2.5RC  | 8           | 26.2                           | 26.9       | 27.6       | 22.3 |
| DF1BA-9EP-2.5RC  | 9           | 28.7                           | 29.4       | 30.1       | 24.8 |
| DF1BA-10EP-2.5RC | 10          | 31.2                           | 31.9       | 32.6       | 27.3 |

Note 1 : The installation hole size C varies based on the panel board thickness.

Note 2 : Fabricate installation holes so that no burrs occur.

## Double Row In-line Plug (Friction Lock Type)



Shown with Contacts Inserted  
 ●Applicable Socket : DF1B-#DS-2.5RC



Note : The 4pos. connector differs from the above figure and has a single center indentation to prevent mis-insertion.

Unit : mm

| Part No.          | HRS No.          | No. of Pos. | A    | B    | Purchase Unit  |
|-------------------|------------------|-------------|------|------|----------------|
| DF1BA-4DEP-2.5RC  | CL0541-0719-7-00 | 4           | 2.5  | 8.6  | 100pcs per bag |
| DF1BA-6DEP-2.5RC  | CL0541-0720-6-00 | 6           | 5.0  | 11.1 |                |
| DF1BA-8DEP-2.5RC  | CL0541-0721-9-00 | 8           | 7.5  | 13.6 |                |
| DF1BA-10DEP-2.5RC | CL0541-0722-1-00 | 10          | 10.0 | 16.1 |                |
| DF1BA-12DEP-2.5RC | CL0541-0723-4-00 | 12          | 12.5 | 18.6 |                |
| DF1BA-14DEP-2.5RC | CL0541-0724-7-00 | 14          | 15.0 | 21.1 |                |
| DF1BA-16DEP-2.5RC | CL0541-0725-0-00 | 16          | 17.5 | 23.6 |                |
| DF1BA-18DEP-2.5RC | CL0541-0726-2-00 | 18          | 20.0 | 26.1 |                |
| DF1BA-20DEP-2.5RC | CL0541-0727-5-00 | 20          | 22.5 | 28.6 |                |
| DF1BA-22DEP-2.5RC | CL0541-0728-8-00 | 22          | 25.0 | 31.1 |                |
| DF1BA-24DEP-2.5RC | CL0541-0729-0-00 | 24          | 27.5 | 33.6 |                |
| DF1BA-26DEP-2.5RC | CL0541-0730-0-00 | 26          | 30.0 | 36.1 |                |
| DF1BA-28DEP-2.5RC | CL0541-0731-2-00 | 28          | 32.5 | 38.6 |                |
| DF1BA-30DEP-2.5RC | CL0541-0732-5-00 | 30          | 35.0 | 41.1 |                |
| DF1BA-34DEP-2.5RC | CL0541-0734-0-00 | 34          | 40.0 | 46.1 |                |

## Panel Cutouts



Note : Do not use a rounded surface at the panel tab portion.

Unit : mm

| Applicable Plug   | No. of Pos. | C                              |            |            | D    |
|-------------------|-------------|--------------------------------|------------|------------|------|
|                   |             | Panel Board Thickness (Note 1) |            |            |      |
|                   |             | 0.5 to 1.2                     | 1.3 to 1.6 | 1.7 to 2.0 |      |
| DF1BA-4DEP-2.5RC  | 4           | 12.7                           | 13.4       | 14.1       | 8.8  |
| DF1BA-6DEP-2.5RC  | 6           | 15.2                           | 15.9       | 16.6       | 11.3 |
| DF1BA-8DEP-2.5RC  | 8           | 17.7                           | 18.4       | 19.1       | 13.8 |
| DF1BA-10DEP-2.5RC | 10          | 20.2                           | 20.9       | 21.6       | 16.3 |
| DF1BA-12DEP-2.5RC | 12          | 22.7                           | 23.4       | 24.1       | 18.8 |
| DF1BA-14DEP-2.5RC | 14          | 25.2                           | 25.9       | 26.6       | 21.3 |
| DF1BA-16DEP-2.5RC | 16          | 27.7                           | 28.4       | 29.1       | 23.8 |
| DF1BA-18DEP-2.5RC | 18          | 30.2                           | 30.9       | 31.6       | 26.3 |
| DF1BA-20DEP-2.5RC | 20          | 32.7                           | 33.4       | 34.1       | 28.8 |
| DF1BA-22DEP-2.5RC | 22          | 35.2                           | 35.9       | 36.6       | 31.3 |
| DF1BA-24DEP-2.5RC | 24          | 37.7                           | 38.4       | 39.1       | 33.8 |
| DF1BA-26DEP-2.5RC | 26          | 40.2                           | 40.9       | 41.6       | 36.3 |
| DF1BA-28DEP-2.5RC | 28          | 42.7                           | 43.4       | 44.1       | 38.8 |
| DF1BA-30DEP-2.5RC | 30          | 45.2                           | 45.9       | 46.6       | 41.3 |
| DF1BA-34DEP-2.5RC | 34          | 50.2                           | 50.9       | 51.6       | 46.3 |

Note 1 : The installation hole size C varies based on the panel board thickness.

Note 2 : Fabricate installation holes so that no burrs occur.

## Single Row In-line Socket (Positive Lock Type)



Shown with Contacts Inserted

●Applicable Socket : DF1B-#EP-2.5RC



Unit : mm

| Part No.        | HRS No.          | No. of Pos. | A    | B    | Purchase Unit     |
|-----------------|------------------|-------------|------|------|-------------------|
| DF1B-2ES-2.5RC  | CL0541-0320-8-00 | 2           | 2.5  | 6.5  | 100pcs<br>per bag |
| DF1B-3ES-2.5RC  | CL0541-0321-0-00 | 3           | 5.0  | 9.0  |                   |
| DF1B-4ES-2.5RC  | CL0541-0322-3-00 | 4           | 7.5  | 11.5 |                   |
| DF1B-5ES-2.5RC  | CL0541-0323-6-00 | 5           | 10.0 | 14.0 |                   |
| DF1B-6ES-2.5RC  | CL0541-0324-9-00 | 6           | 12.5 | 16.5 |                   |
| DF1B-7ES-2.5RC  | CL0541-0325-1-00 | 7           | 15.0 | 19.0 |                   |
| DF1B-8ES-2.5RC  | CL0541-0326-4-00 | 8           | 17.5 | 21.5 |                   |
| DF1B-9ES-2.5RC  | CL0541-0327-7-00 | 9           | 20.0 | 24.0 |                   |
| DF1B-10ES-2.5RC | CL0541-0328-0-00 | 10          | 22.5 | 26.5 |                   |

## Panel Cutouts

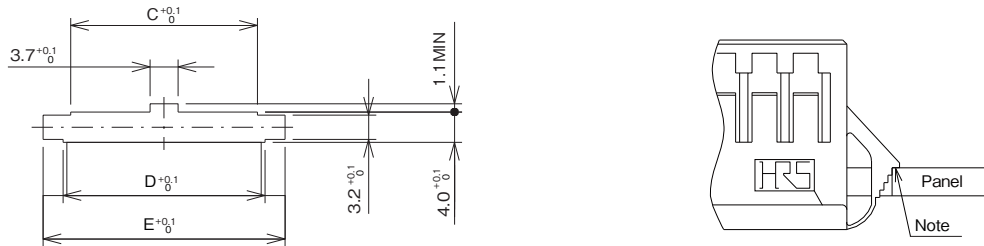

Note : Do not use a rounded surface at the panel tab portion.

Unit : mm

| Applicable Plug | No. of Pos. | C    | D    | E                              |            |            |
|-----------------|-------------|------|------|--------------------------------|------------|------------|
|                 |             |      |      | Panel Board Thickness (Note 1) |            |            |
|                 |             |      |      | 0.5 to 1.2                     | 1.3 to 1.6 | 1.7 to 2.0 |
| DF1B-2ES-2.5RC  | 2           | 4.7  | 6.7  | 10.8                           | 11.3       | 12.0       |
| DF1B-3ES-2.5RC  | 3           | 7.2  | 9.2  | 13.3                           | 13.8       | 14.5       |
| DF1B-4ES-2.5RC  | 4           | 9.7  | 11.7 | 15.8                           | 16.3       | 17.0       |
| DF1B-5ES-2.5RC  | 5           | 12.2 | 14.2 | 18.3                           | 18.8       | 19.5       |
| DF1B-6ES-2.5RC  | 6           | 14.7 | 16.7 | 20.8                           | 21.3       | 22.0       |
| DF1B-7ES-2.5RC  | 7           | 17.2 | 19.2 | 23.3                           | 23.8       | 24.5       |
| DF1B-8ES-2.5RC  | 8           | 19.7 | 21.7 | 25.8                           | 26.3       | 27.0       |
| DF1B-9ES-2.5RC  | 9           | 22.2 | 24.2 | 28.3                           | 28.8       | 29.5       |
| DF1B-10ES-2.5RC | 10          | 24.7 | 26.7 | 30.8                           | 31.3       | 32.0       |

Note 1 : The installation hole size E varies based on panel board thickness.

Note 2 : Fabricate installation holes so that no burrs occur.

## Double Row In-line Socket (Positive Lock Type)



Shown with Contacts Inserted  
 ●Applicable Socket : DF1B-#DEP-2.5RC



Unit : mm

| Part No.         | HRS No.          | No. of Pos. | A    | B    | Purchase Unit  |
|------------------|------------------|-------------|------|------|----------------|
| DF1B-10DES-2.5RC | CL0541-0351-1-00 | 10          | 10.0 | 15.0 | 100pcs per bag |
| DF1B-12DES-2.5RC | CL0541-0352-4-00 | 12          | 12.5 | 17.5 |                |
| DF1B-14DES-2.5RC | CL0541-0353-7-00 | 14          | 15.0 | 20.0 |                |
| DF1B-16DES-2.5RC | CL0541-0354-0-00 | 16          | 17.5 | 22.5 |                |
| DF1B-18DES-2.5RC | CL0541-0346-1-00 | 18          | 20.0 | 25.0 |                |
| DF1B-20DES-2.5RC | CL0541-0355-2-00 | 20          | 22.5 | 27.5 |                |
| DF1B-22DES-2.5RC | CL0541-0356-5-00 | 22          | 25.0 | 30.0 |                |
| DF1B-24DES-2.5RC | CL0541-0357-8-00 | 24          | 27.5 | 32.5 |                |
| DF1B-26DES-2.5RC | CL0541-0358-0-00 | 26          | 30.0 | 35.0 |                |
| DF1B-28DES-2.5RC | CL0541-0359-3-00 | 28          | 32.5 | 37.5 |                |
| DF1B-30DES-2.5RC | CL0541-0360-2-00 | 30          | 35.0 | 40.0 |                |
| DF1B-32DES-2.5RC | CL0541-0361-5-00 | 32          | 37.5 | 42.5 |                |
| DF1B-34DES-2.5RC | CL0541-0362-8-00 | 34          | 40.0 | 45.0 |                |

## Panel Cutouts



Note : Do not use a rounded surface at the panel tab portion.

Unit : mm

| Applicable Plug  | No. of Pos. | C                              |            |            | D    | E   |
|------------------|-------------|--------------------------------|------------|------------|------|-----|
|                  |             | Panel Board Thickness (Note 1) |            |            |      |     |
|                  |             | 0.5 to 1.2                     | 1.3 to 1.6 | 1.7 to 2.0 |      |     |
| DF1B-10DES-2.5RC | 10          | 19.1                           | 19.8       | 20.5       | 15.2 | 3.7 |
| DF1B-12DES-2.5RC | 12          | 21.6                           | 22.3       | 23.0       | 17.7 | 3.7 |
| DF1B-14DES-2.5RC | 14          | 24.1                           | 24.8       | 25.5       | 20.2 | 3.7 |
| DF1B-16DES-2.5RC | 16          | 26.6                           | 27.3       | 28.0       | 22.7 | 3.7 |
| DF1B-18DES-2.5RC | 18          | 29.1                           | 29.8       | 30.5       | 25.2 | 3.7 |
| DF1B-20DES-2.5RC | 20          | 31.6                           | 32.3       | 33.0       | 27.7 | 5.2 |
| DF1B-22DES-2.5RC | 22          | 34.1                           | 34.8       | 35.5       | 30.2 | 5.2 |
| DF1B-24DES-2.5RC | 24          | 36.6                           | 37.3       | 38.0       | 32.7 | 5.2 |
| DF1B-26DES-2.5RC | 26          | 39.1                           | 39.8       | 40.5       | 35.2 | 5.2 |
| DF1B-28DES-2.5RC | 28          | 41.6                           | 42.3       | 43.0       | 37.7 | 5.2 |
| DF1B-30DES-2.5RC | 30          | 44.1                           | 44.8       | 45.5       | 40.2 | 5.2 |
| DF1B-32DES-2.5RC | 32          | 46.6                           | 47.3       | 48.0       | 42.7 | 5.2 |
| DF1B-34DES-2.5RC | 34          | 49.1                           | 49.8       | 50.5       | 45.2 | 5.2 |

Note 1 : The installation hole size C varies based on panel board thickness.

Note 2 : Fabricate installation holes so that no burrs occur.

## Single Row In-line Plug (Positive Lock Type)



Shown with Contacts Inserted  
 ●Applicable Socket : DF1B-#ES-2.5RC



Unit : mm

| Part No.        | HRS No.          | No. of Pos. | A    | B    | Purchase Unit  |
|-----------------|------------------|-------------|------|------|----------------|
| DF1B-2EP-2.5RC  | CL0541-0332-7-00 | 2           | 8.9  | 2.5  | 100pcs per bag |
| DF1B-3EP-2.5RC  | CL0541-0333-0-00 | 3           | 11.4 | 5.0  |                |
| DF1B-4EP-2.5RC  | CL0541-0334-2-00 | 4           | 13.9 | 7.5  |                |
| DF1B-5EP-2.5RC  | CL0541-0335-5-00 | 5           | 16.4 | 10.0 |                |
| DF1B-6EP-2.5RC  | CL0541-0336-8-00 | 6           | 18.9 | 12.5 |                |
| DF1B-7EP-2.5RC  | CL0541-0337-0-00 | 7           | 21.4 | 15.0 |                |
| DF1B-8EP-2.5RC  | CL0541-0338-3-00 | 8           | 23.9 | 17.5 |                |
| DF1B-9EP-2.5RC  | CL0541-0339-6-00 | 9           | 26.4 | 20.0 |                |
| DF1B-10EP-2.5RC | CL0541-0340-5-00 | 10          | 28.9 | 22.5 |                |

## Double Row In-line Plug (Positive Lock Type)



Shown with Contacts Inserted

●Applicable Socket : DF1B-#DES-2.5RC

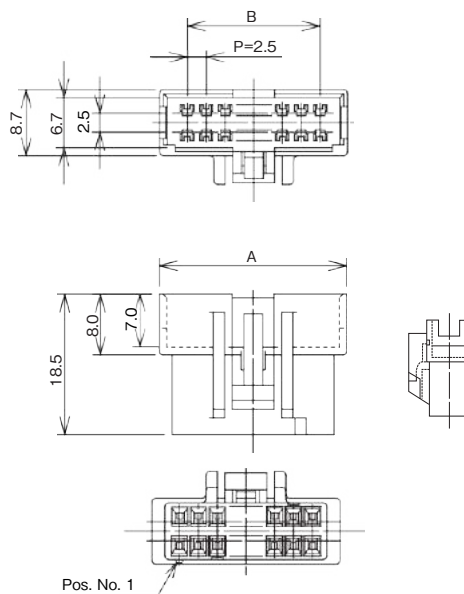

Unit : mm

| Part No.         | HRS No.          | No. of Pos. | A    | B    | Purchase Unit     |
|------------------|------------------|-------------|------|------|-------------------|
| DF1B-10DEP-2.5RC | CL0541-0366-9-00 | 10          | 17.2 | 10.0 | 100pcs<br>per bag |
| DF1B-12DEP-2.5RC | CL0541-0367-1-00 | 12          | 19.7 | 12.5 |                   |
| DF1B-14DEP-2.5RC | CL0541-0368-4-00 | 14          | 22.2 | 15.0 |                   |
| DF1B-16DEP-2.5RC | CL0541-0369-7-00 | 16          | 24.7 | 17.5 |                   |
| DF1B-18DEP-2.5RC | CL0541-0350-9-00 | 18          | 27.2 | 20.0 |                   |
| DF1B-20DEP-2.5RC | CL0541-0370-6-00 | 20          | 29.7 | 22.5 |                   |
| DF1B-22DEP-2.5RC | CL0541-0371-9-00 | 22          | 32.2 | 25.0 |                   |
| DF1B-24DEP-2.5RC | CL0541-0372-1-00 | 24          | 34.7 | 27.5 |                   |
| DF1B-26DEP-2.5RC | CL0541-0373-4-00 | 26          | 37.2 | 30.0 |                   |
| DF1B-28DEP-2.5RC | CL0541-0374-7-00 | 28          | 39.7 | 32.5 |                   |
| DF1B-30DEP-2.5RC | CL0541-0375-0-00 | 30          | 42.2 | 35.0 |                   |
| DF1B-32DEP-2.5RC | CL0541-0376-2-00 | 32          | 44.7 | 37.5 |                   |
| DF1B-34DEP-2.5RC | CL0541-0377-5-00 | 34          | 47.2 | 40.0 |                   |

## Crimping Contact for Socket

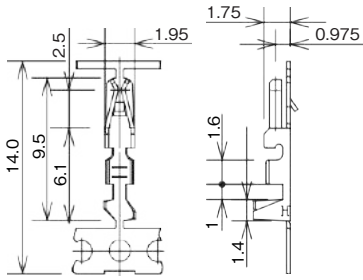

●Strip Length : 2.0 to 2.5mm

### ●Reel Contact Applicable Tool : Applicator

| Part No.      | HRS No.          | Finish      | Purchase Unit      | Applicable Cable (Tin Plated Annealing Copper Wire) |     |                   |                      |                 |
|---------------|------------------|-------------|--------------------|---|-----|-------------------|----------------------|-----------------|
|               |                  |             |                    | UL Style  | AWG | Wire Construction | Sectional Area       | Jacket Diameter |
| DF1B-2022SCF  | CL0541-0223-1-00 | Tin Plated  | 10,000pcs per reel | 1061, 1007  | 20  | 21/0.18mm         | 0.540mm <sup>2</sup> | 1.2 to 1.9mm    |
|               |                  |             |                    |   | 22  | 17/0.16mm         | 0.342mm <sup>2</sup> |                 |
| DF1B-2022SCFA | CL0541-0662-1-00 | Gold Plated |                    | 1061, 1007  | 20  | 21/0.18mm         | 0.540mm <sup>2</sup> | 1.2 to 1.9mm    |
|               |                  |             |                    |   | 22  | 17/0.16mm         | 0.342mm <sup>2</sup> |                 |
| DF1B-2428SCF  | CL0541-0678-1-00 | Tin Plated  |                    | 1061, 1007  | 24  | 11/0.16mm         | 0.221mm <sup>2</sup> | 0.9 to 1.5mm    |
|               |                  |             |                    |   | 26  | 7/0.16mm          | 0.141mm <sup>2</sup> |                 |
|               |                  |             |                    |   | 28  | 7/0.127mm         | 0.089mm <sup>2</sup> |                 |
| DF1B-2428SCFA | CL0541-0680-3-00 | Gold Plated |                    | 1061, 1007  | 24  | 11/0.16mm         | 0.221mm <sup>2</sup> | 0.9 to 1.5mm    |
|               |                  |             |                    |   | 26  | 7/0.16mm          | 0.141mm <sup>2</sup> |                 |
|               |                  |             |                    |   | 28  | 7/0.127mm         | 0.089mm <sup>2</sup> |                 |
| DF1B-30SCF    | CL0541-0682-9-00 | Tin Plated  |                    | 1061, 1007  | 30  | 7/0.1mm           | 0.055mm <sup>2</sup> | 0.6 to 1.2mm    |
| DF1B-30SCFA   | CL0541-0684-4-00 | Gold Plated |                    | 1061, 1007  | 30  | 7/0.1mm           | 0.055mm <sup>2</sup> | 0.6 to 1.2mm    |

Note : When using cables other than those specified, contact a Hirose sales representative.

### ●Loose Contact Applicable Tool : Manual Crimping Tool

| Part No.     | HRS No.          | Finish      | Purchase Unit  | Applicable Cable (Tin Plated Annealing Copper Wire) |     |                   |                      |                 |
|--------------|------------------|-------------|----------------|---|-----|-------------------|----------------------|-----------------|
|              |                  |             |                | UL Style  | AWG | Wire Construction | Sectional Area       | Jacket Diameter |
| DF1B-2022SC  | CL0541-0224-4-00 | Tin Plated  | 100pcs per bag | 1007  | 20  | 21/0.18mm         | 0.540mm <sup>2</sup> | 1.8mm           |
|              |                  |             |                |   | 22  | 17/0.16mm         | 0.342mm <sup>2</sup> | 1.6mm           |
| DF1B-2022SCA | CL0541-0663-4-00 | Gold Plated |                | 1007  | 20  | 21/0.18mm         | 0.540mm <sup>2</sup> | 1.8mm           |
|              |                  |             |                |   | 22  | 17/0.16mm         | 0.342mm <sup>2</sup> | 1.6mm           |
| DF1B-2428SC  | CL0541-0679-4-00 | Tin Plated  |                | 1007  | 24  | 11/0.16mm         | 0.221mm <sup>2</sup> | 1.5mm           |
|              |                  |             |                |   | 26  | 7/0.16mm          | 0.141mm <sup>2</sup> | 1.3mm           |
|              |                  |             |                |   | 28  | 7/0.127mm         | 0.089mm <sup>2</sup> | 1.2mm           |
| DF1B-2428SCA | CL0541-0681-6-00 | Gold Plated |                | 1007  | 24  | 11/0.16mm         | 0.221mm <sup>2</sup> | 1.5mm           |
|              |                  |             |                |   | 26  | 7/0.16mm          | 0.141mm <sup>2</sup> | 1.3mm           |
|              |                  |             |                |   | 28  | 7/0.127mm         | 0.089mm <sup>2</sup> | 1.2mm           |
| DF1B-30SC    | CL0541-0683-1-00 | Tin Plated  |                | 1007  | 30  | 7/0.1mm           | 0.055mm <sup>2</sup> | 1.1mm           |
| DF1B-30SCA   | CL0541-0685-7-00 | Gold Plated |                | 1007  | 30  | 7/0.1mm           | 0.055mm <sup>2</sup> | 1.1mm           |

Note : Only the above cables are suitable when using the manual IDC tool.

### ●Crimping Contact Extraction Tool : DF-C-PO(B)

## Crimping Contact for Plug

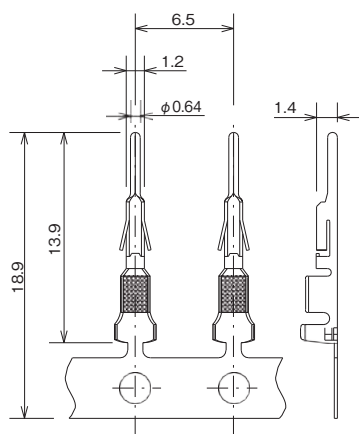

●Strip Length : 3.0 to 3.7mm

●Reel Contact Applicable Tool : Applicator

| Part No.       | HRS No.          | Finish      | Purchase Unit      | Applicable Cable (Tin Plated Annealing Copper Wire) |     |                   |                      |                 |
|----------------|------------------|-------------|--------------------|---|-----|-------------------|----------------------|-----------------|
|                |                  |             |                    | UL Style  | AWG | Wire Construction | Sectional Area       | Jacket Diameter |
| DF1B-2022PCF   | CL0541-0259-9-00 | Tin Plated  | 10,000pcs per reel | 1061, 1007  | 20  | 21/0.18mm         | 0.540mm <sup>2</sup> | 1.2 to 1.9mm    |
|                |                  |             |                    |   | 22  | 17/0.16mm         | 0.342mm <sup>2</sup> |                 |
| DF1B-2022PCFB  | CL0541-0690-7-00 | Gold Plated |                    | 1061, 1007  | 20  | 21/0.18mm         | 0.540mm <sup>2</sup> | 1.2 to 1.9mm    |
|                |                  |             |                    |   | 22  | 17/0.16mm         | 0.342mm <sup>2</sup> |                 |
| DF1B-2428PCF   | CL0541-0664-7-00 | Tin Plated  |                    | 1061, 1007  | 24  | 11/0.16mm         | 0.221mm <sup>2</sup> | 0.9 to 1.5mm    |
|                |                  |             |                    |   | 26  | 7/0.16mm          | 0.141mm <sup>2</sup> |                 |
|                |                  |             |                    |   | 28  | 7/0.127mm         | 0.089mm <sup>2</sup> |                 |
| DF1-PD2428SCFB | CL0541-0660-6-00 | Gold Plated |                    | 1061, 1007  | 24  | 11/0.16mm         | 0.221mm <sup>2</sup> | 0.9 to 1.5mm    |
|                |                  |             |                    |   | 26  | 7/0.16mm          | 0.141mm <sup>2</sup> |                 |
|                |                  |             |                    |   | 28  | 7/0.127mm         | 0.089mm <sup>2</sup> |                 |
| DF1B-30PCF     | CL0541-0686-0-00 | Tin Plated  |                    | 1061, 1007  | 30  | 7/0.1mm           | 0.055mm <sup>2</sup> | 0.6 to 1.2mm    |
| DF1B-30PCFB    | CL0541-0688-5-00 | Gold Plated |                    | 1061, 1007  | 30  | 7/0.1mm           | 0.055mm <sup>2</sup> | 0.6 to 1.2mm    |

Note : When using cables other than those specified, contact a Hirose sales representative.

●Loose Contact Applicable Tool : Manual Crimping Tool

| Part No.      | HRS No.          | Finish      | Purchase Unit  | Applicable Cable (Tin Plated Annealing Copper Wire) |         |                      |                      |                 |
|---------------|------------------|-------------|----------------|---|---------|----------------------|----------------------|-----------------|
|               |                  |             |                | UL Style  | AWG     | Wire Construction    | Sectional Area       | Jacket Diameter |
| DF1B-2022PC   | CL0541-0260-8-00 | Tin Plated  | 100pcs per bag | 1007  | 20      | 21/0.18mm            | 0.540mm <sup>2</sup> | 1.8mm           |
|               |                  |             |                |   | 22      | 17/0.16mm            | 0.342mm <sup>2</sup> | 1.6mm           |
| DF1B-2022PCB  | CL0541-0691-0-00 | Gold Plated |                | 1007  | 20      | 21/0.18mm            | 0.540mm <sup>2</sup> | 1.8mm           |
|               |                  |             |                |   | 22      | 17/0.16mm            | 0.342mm <sup>2</sup> | 1.6mm           |
| DF1B-2428PC   | CL0541-0665-0-00 | Tin Plated  |                | 1007  | 24      | 11/0.16mm            | 0.221mm <sup>2</sup> | 1.5mm           |
|               |                  |             |                |   | 26      | 7/0.16mm             | 0.141mm <sup>2</sup> | 1.3mm           |
|               |                  |             |                |   | 28      | 7/0.127mm            | 0.089mm <sup>2</sup> | 1.2mm           |
| DF1-PD2428SCB | CL0541-0661-9-00 | Gold Plated |                | 1007  | 24      | 11/0.16mm            | 0.221mm <sup>2</sup> | 1.5mm           |
|               |                  |             |                |   | 26      | 7/0.16mm             | 0.141mm <sup>2</sup> | 1.3mm           |
|               |                  |             |                |   | 28      | 7/0.127mm            | 0.089mm <sup>2</sup> | 1.2mm           |
| DF1B-30PC     | CL0541-0687-2-00 | Tin Plated  | 1007           | 30  | 7/0.1mm | 0.055mm <sup>2</sup> | 1.1mm                |                 |
| DF1B-30PCB    | CL0541-0689-8-00 | Gold Plated | 1007           | 30  | 7/0.1mm | 0.055mm <sup>2</sup> | 1.1mm                |                 |

Note : Only the above cables are suitable when using the manual IDC tool.

●Crimping Contact Extraction Tool : DF-C-PO(C)

## Applicable Tool

| Connection Type | Type                 | Part No.            | HRS No.          | Applicable Contacts          |
|-----------------|----------------------|---------------------|------------------|------------------------------|
| Crimping        | Applicator           | AP105-DF1B-2022S    | CL0901-4510-9-00 | DF1B-2022SCF(A)              |
|                 |                      | AP105-DF1B-2428S    | CL0901-4518-0-00 | DF1B-2428SCF(A)              |
|                 |                      | AP105-DF1B-30S      | CL0901-4517-8-00 | DF1B-30SCF(A)                |
|                 |                      | AP105-DF1B-2022P    | CL0901-4509-0-00 | DF1B-2022PCF(B)              |
|                 |                      | AP105-DF1B-2428P    | CL0901-4521-5-00 | DF1B-2428PCF, DF1-PD2428SCFB |
|                 |                      | AP105-DF1B-30P      | CL0901-4519-3-00 | DF1B-30PCF(B)                |
|                 | Manual Crimping Tool | DF1B-TA2022SHC      | CL0550-0182-7-00 | DF1B-2022SC(A)               |
|                 |                      | DF1B-TA2428SHC      | CL0550-0209-1-00 | DF1B-2428SC(A)               |
|                 |                      | DF1B-TA30SHC        | CL0550-0211-3-00 | DF1B-30SC(A)                 |
|                 |                      | DF1B-TA2022PHC      | CL0550-0183-0-00 | DF1B-2022PC(B)               |
|                 |                      | HT802/DF1B-2428P(A) | CL0550-0430-0-00 | DF1B-2428PC, DF1-PD2428SCB   |
|                 |                      | DF1B-TA30PHC        | CL0550-0210-0-00 | DF1B-30PC(B)                 |
| Press Main Unit | CM-105C              | CL0901-0001-0-00    | -                |                              |
| Extraction Tool | DF-C-PO(B)           | CL0550-0179-2-00    | DF1B-####SCF     |                              |
|                 | DF-C-PO(C)           | CL0550-0198-7-00    | DF1B-####PCF     |                              |

Note 1 : Please conduct crimping work according to the table in the Crimp Quality Standard (ETAD-H0909-00, ETAD-H0913-00).

Note 2 : Problems with tools other than those specified by Hirose are outside the scope of warranty.

Note 3 : #### indicates the applicable wire sizes.

Note 4 : When non-authorized tools are used, please consult with Hirose sales representative about provision of the drawing of the crimping tool.

## Crimping

### Items required prior to start crimping

The work-related documents shown below are required before starting harness assembly.

(The ● mark represents required documents.)

Please contact your Hirose sales representative if you do not have these documents.

| Document Title                                | Description  | Automatic Crimping Machine | Hand Crimping Tool | Remarks   |
|---|--|----------------------------|--------------------|---|
| Crimping Machine Main Unit Instruction Manual | Explanation of main press machine unit                       | ●                          | —                  | Bundled with purchase of main press machine unit. |
| Applicator Spare Parts Identification         | Explanation for Applicator installation                      | ●                          | —                  | Bundled with purchase of applicator.              |
| Crimp Conditions                              | Standard Crimp Height and Tensile Strength Values            | ●                          | —                  |   |
| Crimp Quality Standards                       | Various standards for crimping conditions                    | ●                          | —                  |   |
| Operating Instructions for Hand Tool          | Crimp height, Standard values of tensile strength and others | —                          | ●                  | Bundled with purchase of hand tool.               |
| Harness Procedure Manual                      | Harness Procedure  | ●                          | ●                  | Ask a Hirose sales personnel to provide them.     |

### Tools

When crimping work is applied to our contacts, use the tools designated by Hirose.

※Crimping performed with tools other than those designated should be avoided as it may result in contact failure, disconnection of cable, etc.

※The operating instructions manual is available for the crimping machine and the applicator. Be sure to carefully read the operating instructions manual before beginning work.

### Applicable Cables

Check that the cables to be used are within the applicable range.

If you intend to use a cable other than those recommended, contact a sales representative.

[Precautions]

- Cables applicable to crimping connectors are tin-plated stranded soft-copper wire.
- Avoid crimping solid wire, wires with polyester threads or tin coated wires.
- Avoid crimping two cables together.
- The crimp height setting values (Note) may vary between tin-plated and gold-plated terminals even if the same electric wires are used.
- The crimp height setting values (Note) may vary depending on the difference in the core wire configuration even if the computed cross-sectional area is the same.

Note : The crimp height is an important item that determines crimping quality. We execute crimping tests for each electric wire to ensure the optimal value for the crimp height with high precision, thereby ensuring optimal setup values.

## Application Pattern



## Precautions

|                         |   |
|-------------------------|---|
| 1. Cleaning Condition   | Refer to the "Wire-to-Board Connector Use Handbook".  |
| 2. Connection Condition | Refer to the "Wire-to-Board Connector Use Handbook".  |
| 3. Cautions             | The color of the plastic molding may differ slightly depending on product lot and future storage conditions but this does not affect the product performance.<br>Black spots may appear on the mold resin but this does not affect the product quality.   |
| 4. Precaution           | Please refer to the following documents.<br><ul style="list-style-type: none"> <li>■ Crimp Quality Standards (ETAD-H0909-00, ETAD-H0913-00)</li> <li>■ Harness Procedure Manual (ATAD-H0677-00)</li> <li>■ Extraction Tool Procedure Manual</li> <li>■ User Guide for Wire-to-Board Connectors</li> </ul> |

## While Taking into Consideration

Specifications mentioned in this catalog are reference values.

When considering to order or use this product, please review the Drawing and Product Specifications sheets.

Use an appropriate cable when using the connector in combination with cables.

If considering usage of a non-specified cable, please contact your sales representative.

If assembly process is done by jigs & tools which are not identified by Hirose, the warranty of the product may be affected.

If considering usage for below mentioned applications, please contact your sales representative.

In cases where the application will demand a high level of reliability, such as automotive, medical instruments, public infrastructure, aerospace/ defense etc. Hirose must review before assurance of reliability can be given.

**HIROSE**

**HRS** **HIROSE ELECTRIC CO.,LTD.**



2-6-3 Nakagawa Chuoh, Tsuzuki-Ku, Yokohama-Shi 224-8540, JAPAN  
<https://www.hirose.com>

## Looking for pricing, stock, or lifecycle information?

Click below to explore more details on WIN SOURCE:

-  [View DF1B-2022PCFB on WIN SOURCE](#)
-  [Hirose Electric Co Ltd Information](#)

## Optimize Your Supply Chain with WIN SOURCE Solutions

-  Global Sourcing Solution
-  Obsolete Management
-  Cost Control Management
-  Shortage Management
-  Alternative Solution
-  Excess Inventory Management