



THE DATASHEET OF DLPA300PFP



DLPA300 Driver for DLP Digital Micromirror Devices

1 Features

- Designed for the DLP® 9- μ m pixel digital micromirror devices (DMDs)
 - DLP780NE
 - DLP780TE
 - DLP800RE
 - DLP781NE
 - DLP781TE
 - DLP801RE
 - DLP801XE
- Generates the micromirror clocking pulses the 9- μ m pixel DMDs require
- Generates specialized voltage levels required for micromirror clocking pulses

2 Applications

- [Enterprise projector](#)
- [Smart projector](#)
- [Laser TV](#)
- [Digital signage](#)
- Large venue projector
- ProAV projector

3 Description

The DLPA300 device is a micromirror driver for the DLP 9- μ m pixel, high-efficiency digital micromirror devices (DMDs), which include the DLP780NE, DLP780TE, DLP800RE, DLP781NE, DLP781TE, DLP801RE, and DLP801XE DMDs. A part of these DMD chipsets, the DLPA300 micromirror driver generates the V_{OFFSET} and V_{BIAS} voltages. It also switches V_{OFFSET} , V_{BIAS} , and an externally generated V_{RESET} to create the micromirror clocking pulses for the DLP DMDs. Either the TI DLPC4420 or DLPC4430 display controller manages the timing of this waveform.

Device Information

PART NUMBER ⁽¹⁾	PACKAGE	BODY SIZE
DLPA300	HTQFP (80)	14.00 mm × 14.00 mm

(1) For all available packages, see the orderable addendum at the end of this data sheet.

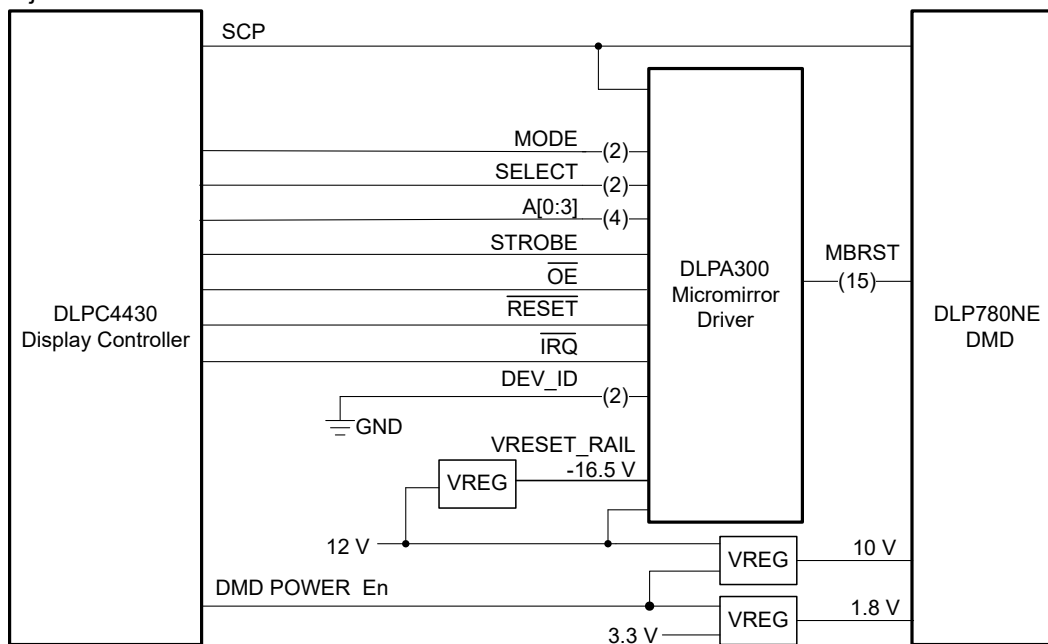

Simplified Application



Table of Contents

1 Features	1	7.4 Device Functional Modes.....	16
2 Applications	1	8 Application and Implementation	17
3 Description	1	8.1 Application Information.....	17
4 Revision History	2	8.2 Typical Application.....	17
5 Pin Configuration and Functions	3	9 Power Supply Recommendations	22
6 Specifications	6	9.1 Power Supply Rail Guidelines.....	22
6.1 Absolute Maximum Ratings.....	6	10 Layout	23
6.2 ESD Ratings.....	6	10.1 Layout Guidelines.....	23
6.3 Recommended Operating Conditions.....	6	10.2 Thermal Considerations.....	23
6.4 Thermal Information.....	7	11 Device and Documentation Support	24
6.5 Electrical Characteristics Control Logic.....	7	11.1 Third-Party Products Disclaimer.....	24
6.6 5-V Linear Regulator.....	8	11.2 Device Support.....	24
6.7 Bias Voltage Boost Converter.....	8	11.3 Documentation Support.....	24
6.8 Reset Voltage Buck-Boost Converter.....	9	11.4 Receiving Notification of Documentation Updates..	24
6.9 V_{OFFSET} Regulator.....	9	11.5 Support Resources.....	24
6.10 Switching Characteristics.....	10	11.6 Trademarks.....	25
7 Detailed Description	12	11.7 Electrostatic Discharge Caution.....	25
7.1 Overview.....	12	11.8 Glossary.....	25
7.2 Functional Block Diagram.....	13	12 Mechanical, Packaging, and Orderable Information	25
7.3 Feature Description.....	14		

4 Revision History

NOTE: Page numbers for previous revisions may differ from page numbers in the current version.

Changes from Revision * (October 2021) to Revision A (June 2023)	Page
• Updated Features for new DMDs.....	1
• Updated Applications	1
• Updated Description for new DMDs.....	1
• Added minimum value to V_{IN} in Absolute Maximum Ratings	6
• Updated F_{SW} in Bias Voltage Boost Converter	8
• Deleted Discharge time constant in V_{OFFSET} Regulator	9
• Added Discharge current sink in V_{OFFSET} Regulator	9
• Updated Overview	12
• Updated drawing for proper logic polarity in Functional Block Diagram	13
• Updated switching frequency in Bias Voltage Boost Converter	14
• Updated Bias Voltage Boost Converter for new DMDs.....	14
• Updated V_{OFFSET} Regulator for new DMDs.....	15
• Updated Application Information	17
• Updated Typical Application	17
• Updated Design Requirements	18
• Corrected minor typos in Detailed Design Procedure	19

5 Pin Configuration and Functions

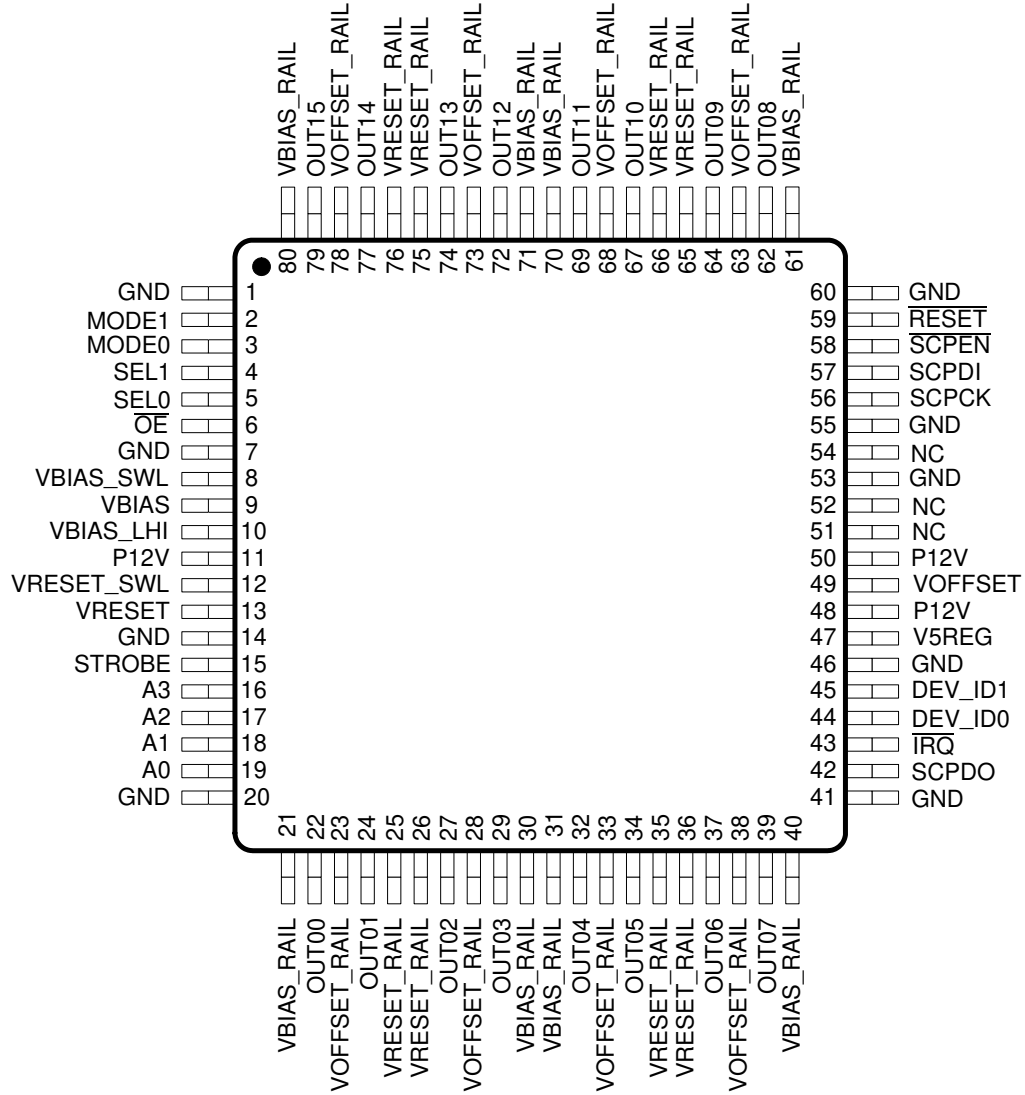

Figure 5-1. PFP Package 80-Pin HTQFP Top View

Table 5-1. Package Pinout

PIN		I/O (INPUT DEFAULT)	DESCRIPTION
NAME	NO.		
OUT00	22	Output	16 micromirror clocking waveform outputs (enabled by $\overline{OE} = 0$)
OUT01	24	Output	
OUT02	27	Output	
OUT03	29	Output	
OUT04	32	Output	
OUT05	34	Output	
OUT06	37	Output	
OUT07	39	Output	
OUT08	62	Output	
OUT09	64	Output	
OUT10	67	Output	
OUT11	69	Output	
OUT12	72	Output	
OUT13	74	Output	
OUT14	77	Output	
OUT15	79	Output	
A0	19	Input (pulldown)	Output Address. Used to select which OUTxx pin is active at a given time
A1	18	Input (pulldown)	
A2	17	Input (pulldown)	
A3	16	Input (pulldown)	
MODE0	3	Input (pulldown)	Mode Select. Used to determine the operating mode of the DLPA300
MODE1	2	Input (pulldown)	
SEL0	5	Input (pulldown)	Output Voltage Select. Used to switch the voltage applied to the addressed OUTxx pin
SEL1	4	Input (pulldown)	
STROBE	15	Input (pulldown)	A rising edge on STROBE latches in the control signals after a tristate delay
\overline{OE}	6	Input (pullup)	Asynchronous input controls whether the 16 OUTxx pins are active or are in a high-impedance state. $\overline{OE} = 0$: Enabled. $\overline{OE} = 1$: High Z
RESET	59	Input (pullup)	Resets the DLPA300 internal logic. Active low. Asynchronous
SCPEN	58	Input (pullup)	Enables serial bus data transfers. Active low
SCPDI	57	Input (pull down)	Serial bus data input. Clocked in on the falling edge of SCPCK
SCPCK	56	Input (pull down)	Serial bus clock. Provided by chipset controller
SCPDO	42	Output	Serial bus data output (open drain). Clocked out on the rising edge of SCPCK. A 1-k Ω pullup resistor to the chip-set controller V_{DD} supply is recommended.
IRQ	43	Output	Interrupt request output to the chipset Controller. Active low. A 1-k Ω pullup resistor to the chip-set controller V_{DD} supply is recommended.
DEV_ID1	45	Input (pullup)	Serial bus device address: 00 = all; 01 = device 1; 10 = device 2; 11 = device 3
DEV_ID0	44	Input (pullup)	
VBIAS	9	Output	One of three specialized voltages the DLPA300 generates
VBIAS_LHI	10	Input	Current limiter output for VBIAS supply (also the VBIAS switching inductor input)
VBIAS_SWL	8	Input	Connection point for VBIAS supply switching inductor
VBIAS_RAIL	21, 30, 31, 40, 61, 70, 71, 80	Input	The internally used VBIAS supply rail. Internally isolated from VBIAS
VRESET	13	No Connect	This pin is unused by the DLPA300.

Table 5-1. Package Pinout (continued)

PIN		I/O (INPUT DEFAULT)	DESCRIPTION
NAME	NO.		
VRESET_SWL	12	No Connect	This pin is unused by the DLPA300.
VRESET_RAIL ⁽¹⁾	25, 26, 35,36, 65, 66, 75, 76	Input	The internally-used VRESET supply rail. Internally isolated from VRESET. The external VRESET supply is connected to this pin. The package thermal pad is tied to this voltage level. ⁽¹⁾
VOFFSET	49	Output	One of three specialized voltages the DLPA300 generates
VOFFSET_RAIL	23, 28, 33, 38, 63, 68, 73, 78	Input	The internally-used VOFFSET supply rail. Internally isolated from VOFFSET
GND	1, 7, 14, 20, 41, 46, 53, 55, 60	GND	Common ground
V5REG	47	Output	The 5-V logic supply output
P12V	11, 48, 50	Input	The main power input to the DLPA300
NC	51, 52, 54	No Connect	No connect

(1) Exposed thermal pad is internally connected to VRESET_RAIL.

6 Specifications

6.1 Absolute Maximum Ratings

over operating free-air temperature range (unless otherwise noted)⁽¹⁾

			MIN	MAX	UNIT
ELECTRICAL					
P12V	Load supply voltage			14	V
VRESET_SWL	Reset supply switching inductor connection point	(VRESET_SWL-VRESET_RAIL)		-1	V
VBIAS_RAIL	Internally-used V _{BIAS} supply rail	(VBIAS_RAIL-VRESET_RAIL)		60	V
VOFFSET_RAIL	Internally-used V _{OFFSET} supply rail	(VOFFSET_RAIL-VRESET_RAIL)		40.5	V
V _{IN}	Logic inputs		-0.3	7	V
V _{OUT}	Open drain logic outputs			7	V
ENVIRONMENTAL					
T _{J(max)}	Maximum junction temperature			125	°C
T _A	Operating temperature		0	75	°C
T _{stg}	Storage temperature		-55	150	°C

- (1) Stresses beyond those listed under [Section 6.1](#) may cause permanent damage to the device. These are stress ratings only, and functional operation of the device at these or any other conditions beyond those indicated under [Section 6.3](#) is not implied. Exposure to absolute-maximum-rated conditions for extended periods may affect device reliability.

6.2 ESD Ratings

			VALUE	UNIT
V _(ESD)	Electrostatic discharge	Human body model (HBM) ⁽¹⁾	±2000	V
		Charged device model (CDM) ⁽²⁾	800	

- (1) JEDEC document JEP155 states that 500 V HBM allows safe manufacturing with a standard ESD control process.

- (2) JEDEC document JEP157 states that 250 V CDM allows safe manufacturing with a standard ESD control process.

6.3 Recommended Operating Conditions

at T_A = 25°C, P12V = 10.8 V to 13.2 V (unless otherwise noted)⁽²⁾

POWER			MIN	NOM	MAX	UNIT
I _{P12V1}	P12V supply current ⁽¹⁾	Global shadow at 50 kHz, OUT load = 39 Ω and 410 pF, V5REG = 30 mA, V _{BIAS} = 21 V at 5 mA, V _{OFFSET} = 10V at 30 mA		200		mA
I _{P12V2}		Outputs disabled and no external loads, V _{BIAS} = 21 V, V _{OFFSET} = 4.5 V			22	mA
T _{JTSDR}	Thermal shutdown temperature	With device temperature rising	145	160	175	°C
		Hysteresis	5	10	15	°C
	Delta between thermal shutdown and thermal warning		5	10	15	°C
T _{JTWR}	Thermal warning temperature	With device temperature rising	125	140	155	°C
		Hysteresis	5	10	15	°C

- (1) During power up the inrush power supply current can be as high as 1 A for a momentary period of time.

- (2) The functional performance of the device specified in this data sheet is achieved when operating the device within the limits defined by the *Recommended Operating Conditions*. No level of performance is implied when operating the device above or below the *Recommended Operating Conditions* limits.

6.4 Thermal Information

THERMAL METRIC ⁽¹⁾	DLPA300	UNIT
	PFP (HTQFP)	
	80 PINS	
R _{c-j} Thermal resistance	3	°C/W

(1) For more information about traditional and new thermal metrics, see the *Semiconductor and IC Package Thermal Metrics* application report, [SPRA953](#).

6.5 Electrical Characteristics Control Logic

T_A = 25°C, P12V = 10.8 V to 13.2 V (unless otherwise noted)

PARAMETER	TEST CONDITIONS	MIN	TYP	MAX	UNIT
V _{IL} Low-level logic input voltage				0.8	V
V _{IH} High-level logic input voltage		1.97			V
I _{IH} High-level logic input current	V _{IN} = 5 V, input with pulldown. See terminal functions table.		40	50	μA
I _{IL} Low-level logic input current	V _{IN} = 0 V, input with pullup. See terminal functions table.	-50	-40		μA
I _{IH} High-level logic input leakage current	V _{IN} = 0 V, input with pulldown	-1		1	μA
I _{IL} Low-level logic input leakage current	V _{IN} = 5 V, input with pullup	-1		1	μA
V _{OL} Open drain logic outputs	I = 4 mA			0.4	V
I _{OL} Logic output leakage current	V = 3.3 V			1	μA

6.6 5-V Linear Regulator

$T_A = 25^\circ\text{C}$, P12V = 10.8 V to 13.2 V (unless otherwise noted)

PARAMETER		TEST CONDITIONS	MIN	TYP	MAX	UNIT
V _{5REG}	Output voltage	Average voltage, I _{OUT} = 4 mA to 50 mA	4.75	5	5.25	V
I _{IL}	Output current: internal logic		4		20	mA
I _{IE}	Output current: external circuitry		0		30	mA
I _{CL5}	Current limit		80			mA
V _{UV5}	Undervoltage threshold	I _{OUT} = 50 mA	V5REG voltage increasing, P12V = 5.4 V		4.1	V
			V5REG voltage falling, P12V = 5.2 V		3.9	
V _{RIP}	Output ripple voltage ⁽¹⁾				200	mVpk-pk
V _{OS5}	Voltage overshoot at start up				2	%V5REG
t _{SS}	Power up	Measured between 10 to 90% of V5REG			1	ms

(1) Output ripple voltage relies on suitable external components being selected and good printed circuit board layout practice.

6.7 Bias Voltage Boost Converter

$T_A = 25^\circ\text{C}$, P12V = 10.8 V to 13.2 V (unless otherwise noted)

PARAMETER		TEST CONDITIONS	MIN	TYP	MAX	UNIT
I _{RL}	Output current: reset outputs	Load = 400pF, 39 Ω, repetition frequency = 50 kHz	0		18	mA
I _{QL}	Output current: quiescent / drivers	Load = 400 pF, 39 Ω, repetition frequency = 50 kHz			3	mA
I _{DL}	Output current: DMD load		0		5	mA
I _{CLFB}	Current limit flag	Corresponding current on output at P12V = 10.8 V	30			mA
I _{CLB}	Current limit	Measured on input	330	376	460	mA
V _{BIAS}	Output voltage		20.5	21	21.5	V
V _{UVB}	V _{BIAS} undervoltage threshold	Bias voltage falling	50		92	%VBIAS
V _{UVLHI}	VBIAS_LHI undervoltage threshold	VBIAS_LHI voltage increasing		8		V
		VBIAS_LHI voltage falling		6.5		V
R _{DS}	Boost switch R _{DS(on)}	T _J = 25°C		2		Ω
V _{RIP}	Output ripple voltage ⁽¹⁾				200	mVpk-pk
F _{SW}	Switching frequency		1.1	1.3	1.5	MHz
V _{OSB}	Voltage overshoot at start up				2	%VBIAS
t _{SS}	Power up	C _{OUT} = 3.3 μF, Measured between 10 to 90% of target V _{BIAS}			1	ms
t _{dis}	Discharge current sink		400			mA

(1) Output ripple voltage relies on suitable external components being selected and good printed circuit board layout practice.

6.8 Reset Voltage Buck-Boost Converter

This feature is not used in the DLPA300.

6.9 V_{OFFSET} Regulator

T_A = 25°C, P12V = 10.8 V to 13.2 V (unless otherwise noted)

PARAMETER		TEST CONDITIONS	MIN	TYP	MAX	UNIT
I _{RL}	Output current: reset outputs	Load = 400 pF, 39 Ω, repetition frequency = 50 kHz	0		12.2	mA
I _{QL}	Output current: quiescent / drivers	Load = 400 pF, 39 Ω, repetition frequency = 50 kHz			3	mA
I _{DL}	Output current		0		30	mA
I _{CLO}	Current limit		100			mA
V _{OFFSET}	Output Voltage		9.75	10	10.25	V
V _{UVO}	Undervoltage threshold	V _{OFFSET} voltage falling	50		92	%V _{OFFSET}
V _{RIP}	Output ripple voltage ⁽¹⁾				100	mVpk-pk
V _{OSO}	Voltage overshoot at start-up				2	%V _{OFFSET}
t _{ss}	Power up	C _{OUT} = 4.7 μF, Measured between 10 to 90% of target V _{OFFSET}			1	ms
I _{dis}	Discharge current sink		400			mA

(1) Output ripple voltage relies on suitable external components being selected and good printed circuit board layout practice.

6.10 Switching Characteristics

over operating free-air temperature range (unless otherwise noted)

PARAMETER		TEST CONDITIONS	MIN	TYP	MAX	UNIT
SERIAL COMMUNICATION PORT INTERFACE						
A ⁽¹⁾	Setup $\overline{\text{SCPEN}}$ low to SCPCK	Reference to rising edge of SCPCK	360			ns
B ⁽¹⁾	Byte to byte delay	Nominally 1 SCPCK cycle, rising edge to rising edge	1.9			μs
C ⁽¹⁾	Setup SCPDI to $\overline{\text{SCPEN}}$ high	Last byte to secondary disable	360			ns
D ⁽¹⁾	SCPCK frequency ⁽²⁾		0		526	kHz
	SCPCK period		1.9	2		μs
E ⁽¹⁾	SCPCK high or low time		300			ns
F ⁽¹⁾	SCPDI set-up time	Reference to falling edge of SCPCK	300			ns
G ⁽¹⁾	SCPDI hold time	Reference from falling edge of SCPCK	300			ns
H ⁽¹⁾	SCPDO propagation delay	Reference from rising edge of SCPCK			300	ns
	$\overline{\text{SCPEN}}$, SCPCK, SCPDI, RESET filter (pulse reject)		150			ns
OUTPUT MICROMIRROR CLOCKING PULSES						
F _{PREP}	Phased reset repetition frequency each output pin (non-overlapping)				50	kHz
F _{GREP}	Global reset repetition frequency all output pins				50	kHz
I _{RLK}	V _{RESET} output leakage current	$\overline{\text{OE}} = 1$, V _{RESET_RAIL} = -28.5V		-1	-10	μA
I _{BLK}	V _{BIAS} output leakage current	$\overline{\text{OE}} = 1$, V _{BIAS_RAIL} = 28.5V		1	10	μA
I _{OLK}	V _{OFFSET} output leakage current	$\overline{\text{OE}} = 1$, V _{OFFSET_RAIL} = 10.25V		1	10	μA
OUTPUT MICROMIRROR CLOCKING PULSE CONTROLS						
t _{SPW}	STROBE pulse width		10			ns
t _{SP}	STROBE period		20			ns
t _{OHZ}	Output time to high impedance	$\overline{\text{OE}}$ Pin = High			100	ns
t _{OEN}	Output enable time from high impedance	$\overline{\text{OE}}$ Pin = Low			100	ns
t _{SUS}	Set-up time	From A[3:0], MODE[1:0], and SEL[1:0] to STROBE edge	8			ns
t _{HOS}	Hold time	From A[3:0], MODE[1:0], and SEL[1:0] to STROBE edge	8			ns
t _{PBR}	Propagation time	From STROBE to V _{BIAS} /V _{RESET} edge 50% point.	80		200	ns
t _{PRO}		From STROBE to V _{RESET} /V _{OFFSET} edge 50% point.	80		200	ns
t _{POB}		From STROBE to V _{OFFSET} /V _{BIAS} edge 50% point.	80		200	ns
t _{DEL}	Edge-to-edge propagation delta	Maximum difference between the slowest and fastest propagation times for any given reset output.			40	ns
t _{CHCH}	Output channel-to-channel propagation delta	Maximum difference between the slowest and fastest propagation times for any two outputs for any given edge.			20	ns

(1) See [Figure 6-1](#)

(2) There is no minimum speed for the serial port. It can be written to statically for diagnostic purposes.

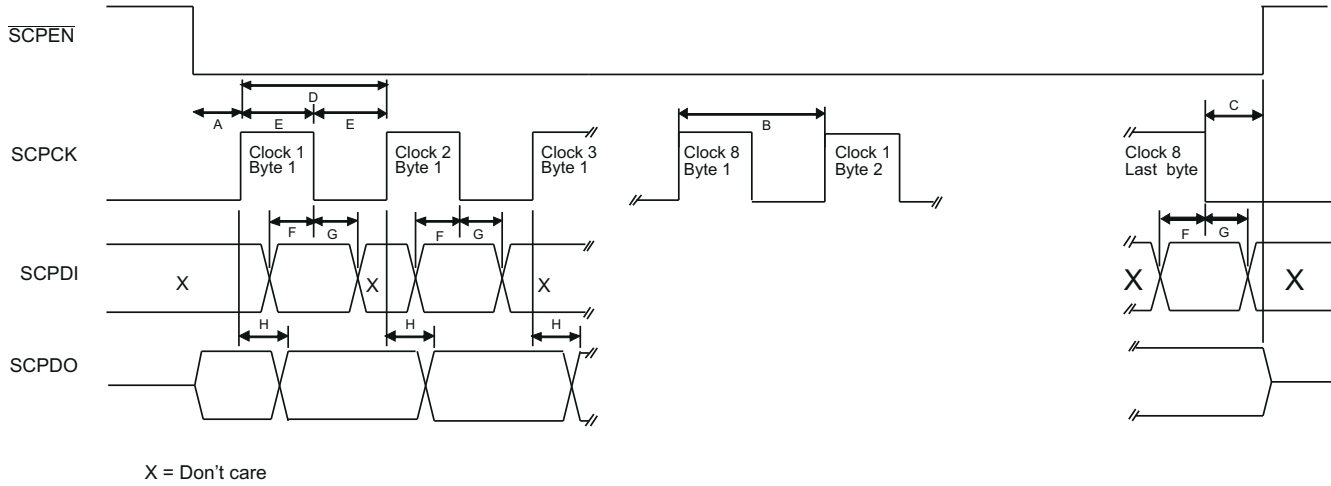

Figure 6-1. Serial Interface Timing

7 Detailed Description

7.1 Overview

The DLPA300 is a micromirror driver for the 9- μm pixel family of DMDs. These include the DLP780NE, DLP800RE, DLP780TE, DLP781NE, DLP781TE, DLP801RE and DLP801XE DMDs. The DLPA300 micromirror driver generates V_{OFFSET} and V_{BIAS} voltages required by the DMD. V_{RESET} for the DMDs is generated by an external voltage regulator. Under the control of the DLPC4430 (or DLPC4420) display controller, the DLPA300 micromirror driver switches these three voltage supplies to control the micromirror reset waveform via the MBRST pins on the DMD.

Reliable function and operation of the DLPA300 micromirror driver require that it is used as part of the family of 9- μm pixel DMD chipsets. For LED and RGB direct laser illumination, the DLPA100 can be replaced by discrete power supply ICs and a power supply sequencer.

The DLPA300 consists of three functional blocks: a high-voltage power supply function, a DMD micromirror clock generation function, and a serial communication (SCP) function.

The high-voltage power supply function generates two specialized voltage levels: V_{BIAS} (21-V) and V_{OFFSET} (10-V). The exact values are controlled by the DLPC4430 or DLPC4420 display controller. V_{RESET} is generated by external voltage regulator.

The micromirror clock generation function uses the two voltages generated by the high-voltage power supply function and the one generated by the external voltage regulator to create the fifteen micromirror clock pluses (output the OUT[0:14] pins of the DLPA300). OUT15 is unused.

The serial communication function allows the display controller to control the generation of V_{BIAS} , V_{RESET} , and V_{OFFSET} ; control the generation of the micromirror clock pulses; and control the general operation of the DLPA300 micromirror driver.

7.2 Functional Block Diagram

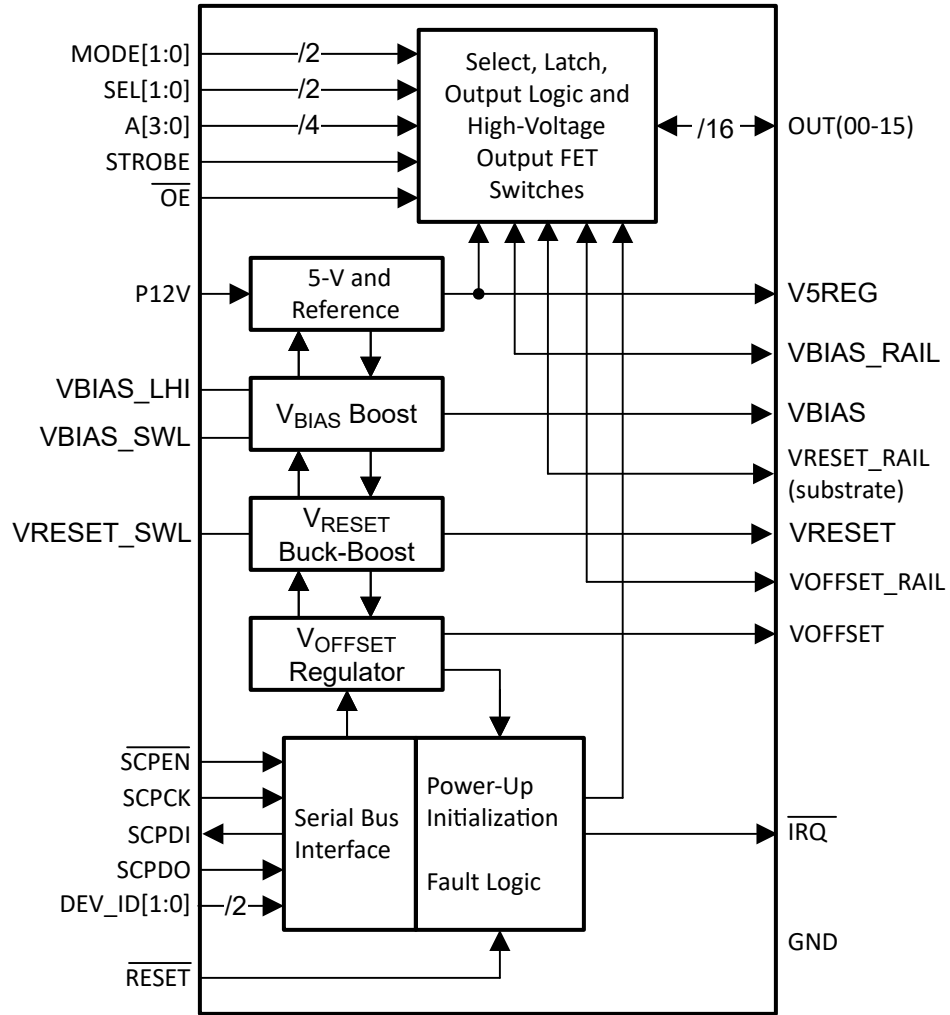

7.3 Feature Description

7.3.1 5-V Linear Regulator

The 5-V linear regulator supplies the 5-V needed for the internal logic of the DLPA300 micromirror driver. It can also provide 5-V, up to 30 mA, for external peripherals.

Figure 7-1 shows the block diagram of this module. The input decoupling capacitors are shared with other internal DLPA300 modules. See Section 8.2.2.1 for recommended component values.

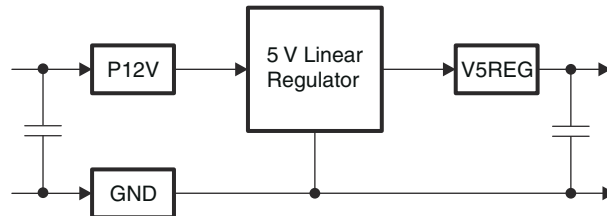

Figure 7-1. 5-Volt Linear Regulator Block Diagram

7.3.2 Bias Voltage Boost Converter

The bias voltage converter is a switching supply that operates at 1.3 MHz. The converter supplies the internal bias voltage for the high voltage FET switches. The V_{BIAS} voltage level for the 9- μm pixel family of DMDs is 21V. The V_{BIAS} voltage level is configured by the DLP display controller chip over the serial communication port (SCP). Four control bits select the voltage level while a fifth bit is the on/off control. The module provides two status bits to indicate latched and unlatched status bits for under-voltage (V_{UV}) and current-limit (C_L) conditions.

Figure 7-2 shows the block diagram of this module. The input decoupling capacitors are shared with other internal DLPA300 modules. See Section 8.2.2.1 for recommended component values.

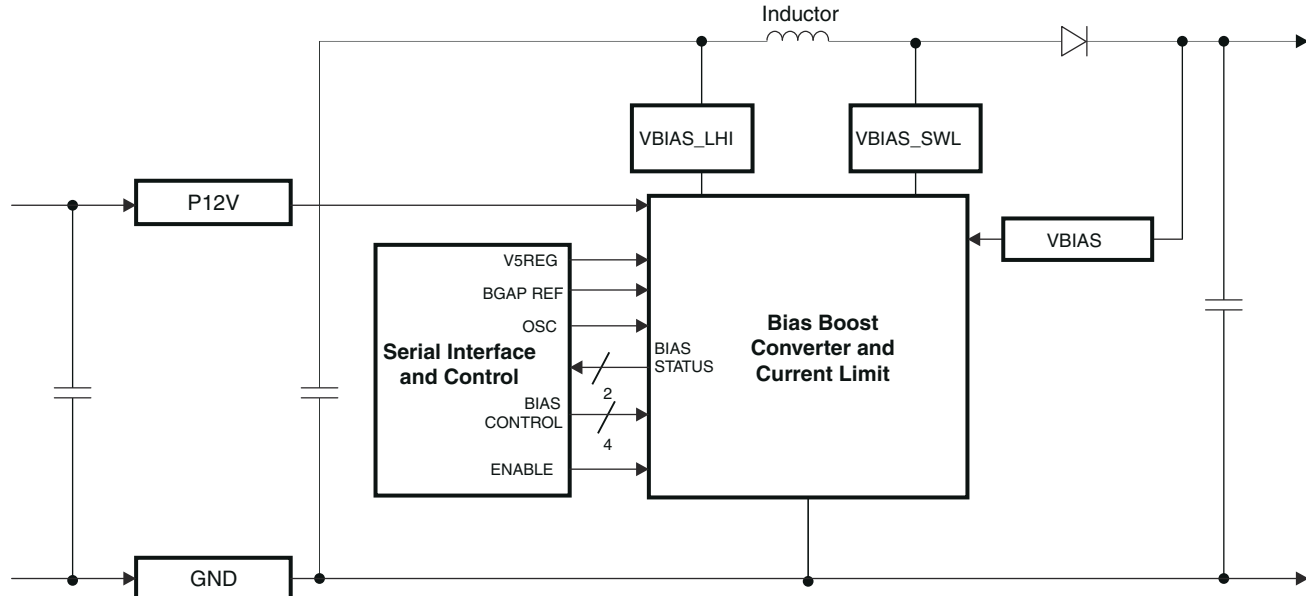

Figure 7-2. Bias Voltage Boost Converter Block Diagram

7.3.3 Reset Voltage Buck-Boost Converter

The internal reset voltage buck-boost converter in the DLPA300 is unused. An external voltage regulator is used to generate the -16.5-V for V_{RESET} . The output of this regulator is connected to the V_{RESET_RAIL} pin on the DLPA300 micromirror driver.

The external voltage regulator provide reset voltage level for the high voltage FET switches. The internal reset voltage buck-boost converter is disabled by the DLP display controller over the serial communication port.

7.3.4 V_{OFFSET} Regulator

The V_{OFFSET} regulator supplies the internal V_{OFFSET} voltage for the high voltage FET switches. The V_{OFFSET} voltage level for the 9- μm pixel family of DMDs is 10-V during normal operation and 4.5-V during power down. The V_{OFFSET} voltage level is configured by the DLP controller chip over the serial communication port. Four control bits select the voltage level while a fifth bit is the on/off control. The module provides two status bits to indicate latched and unlatched status bits for undervoltage (V_{UV}) and current-limit (C_L) conditions.

Figure 7-3 shows the block diagram of this module. The input decoupling capacitors are shared with other DLPA300 modules. See Section 8.2.2.1 for recommended component values.

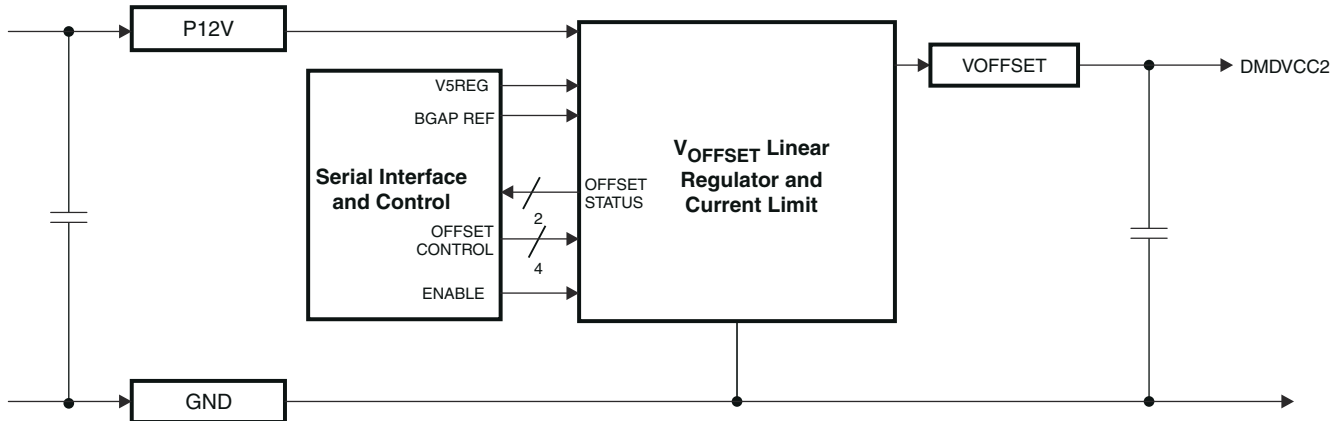

Figure 7-3. Offset Voltage Boost Converter Block Diagram

7.3.5 Serial Communications Port (SCP)

The SCP is a full duplex, synchronous, character-oriented (byte) port that allows exchange of data between the DLPC4430 or DLPC4420 display controller, and the DLPA300 micromirror driver (and other DLP devices). The display controller is the primary on the SCP bus. The DLPA300 micromirror driver is the secondary on the SCP bus.

Table 7-1. Serial Communications Port Signal Definitions

SIGNAL	I/O	FROM/TO	TYPE	DESCRIPTION
SCPCK	I	SCP bus primary to secondary	LVTTTL compatible	SCP bus serial transfer clock. The host processor (primary) generates this clock.
$\overline{\text{SCPEN}}$	I	SCP bus primary to secondary	LVTTTL compatible	SCP bus access enable (low true). When high, secondary resets to the idle state, and SCPDO output is tristated. Pulling $\overline{\text{SCPEN}}$ low initiates a read or write access. $\overline{\text{SCPEN}}$ must remain low for an entire read/write access, and must be pulled high after the last data cycle. To abort a read or write cycle, pull $\overline{\text{SCPEN}}$ high at any point.
SCPD _I	I	SCP bus primary to secondary	LVTTTL compatible	SCP bus serial data input. Data bits are valid and must be clocked in on the falling edge of SCPCK.
SCPD _O	O	SCP bus secondary to primary	LVTTTL, open drain w/tristate	SCP bus serial data output. Data bits must clocked out on the rising edge of SCPCK. A 1-k Ω pullup resistor to the 3.3-V display controller supply is required.
$\overline{\text{IRQ}}$	O	SCP bus secondary to primary	LVTTTL, open drain	Not part of the SCP bus definition. Asynchronous interrupt signal from secondary to request service from the primary. A 1-k Ω pullup resistor to the 3.3-V display controller supply is required.

7.4 Device Functional Modes

At power up, the DLPC4430 or DLPC4420 display controller configures the DLPA300 over the SCP bus. There are two device functional modes. When $\overline{\text{OE}}$ is high, OUT[0:14] are tristated. When $\overline{\text{OE}}$ is low, the OUT[0:14] are active under the control of the display controller.

8 Application and Implementation

Note

Information in the following applications sections is not part of the TI component specification, and TI does not warrant its accuracy or completeness. TI's customers are responsible for determining suitability of components for their purposes, as well as validating and testing their design implementation to confirm system functionality.

8.1 Application Information

DMDs are spatial light modulators which reflect incoming light from an illumination source to one of two directions, with the primary direction being into a projection or collection optic. Each application is derived primarily from the optical architecture of the system and the format of the data coming into the DLP display controller. Typical applications using the DLP780NE, DLP800RE and DLP780TE chipsets include laserTVs, smart projectors, enterprise projectors and digital signage. The DLP781NE, DLP781TE, DLP801RE and DLP801XE are used in higher brightness applications such as ProAV and large venue projectors.

DMD power-up and power-down sequencing is strictly controlled by the DLP display controller through the DLPA300. Refer to *Power Supply Recommendations* section in the DLP780NE, DLP780TE, DLP800RE, DLP781NE, DLP781TE, DLP801RE and DLP801XE datasheets for power-up and power-down specifications. To ensure reliable operation, the DLP780NE, DLP800RE, DLP781NE and DLP801RE DMDs must always be used with DLPC4430 display controller, a DLPA100 power management and motor driver and a DLPA300 micromirror driver. The DLP780TE, DLP781Te and DLP801XE DMDs must always be use with the DLPC4420 display controller, the DLPA100 power management and motor driver and a DLPA300 micromirror driver. For LED and RGB direct laser illumination, the DLPA100 power management and motor driver can be replaced with discrete power supplies that are sequenced to meet the display controller power supply sequencing.

8.2 Typical Application

The DLPA300 micromirror driver controls the switching of the bias, offset and reset voltage levels on the MBRST pins to assure correct DMD operation. It is a controlled by a DLP display controller which synchronizes the display data sent to the DMD with the correct sequencing of the bias, offset and reset voltage levels by the DLPA300 micromirror driver. The typical application shown in [Figure 8-1](#) is a Full-HD display using the DLP780NE chipset. The application is the same for the DLP800RE, DLP781NE or DLP801RE/DLPC4430 chipsets and the DLP780TE, DLP781TE or DLP801XE/dual-DLPC4420 chipsets. The DLPA300 micromirror driver creates V_{BIAS} and V_{OFFSET} with internal voltage regulators. V_{RESET} is created by an external regulator. These voltages are switched by the DLPA300 micromirror driver on the OUT[0:14] pins which are connected to the MBRST pins on the DMD.

waveforms created by the DLPA300 micromirror driver that are input to the MBRST pins on the DMD. This results in the highest possible image quality and system efficiency.

The key design requirements are power supply sequencing for power up and power down. The 9- μm family of DMDs require that the VCC2 supply be turned on after the 1.8-V supply is full on and stable. Similarly, on power down, the DMDs require that the VCC2 supply be full off before the 1.8-V supply is begins its power off ramp.

The DLPA300 micromirror driver imparts one power supply sequencing constraint. Because V_{RESET} is generated by an external supply, the DLPC4430 display controller cannot control this supply directly by software. Therefore, it is necessary to use the V_{BIAS} supply to control the power up and power down of the external V_{RESET} power supply.

These power supply sequencing requirements necessitate external circuitry to control the V_{RESET} and VCC2 power supply sequencing, as seen in [Figure 8-1](#).

8.2.2 Detailed Design Procedure

The DLPC4430 or DLPC4420 display controller configures the V_{BIAS} and V_{OFFSET} voltage regulators in the DLPA300 micromirror driver through the SCP bus. V_{BIAS} is then used to generate the enable signal for the V_{RESET} external voltage regulator, LM43601 step-down voltage converter. When the V_{BIAS} is enabled, it turns on the two-transistor buffer amplifier. The 2N7002 and BSS84-7-F FETs isolate V_{BIAS} from the $V_{\text{RESET_RAIL}}$ and shift the voltage reference to $V_{\text{RESET_RAIL}}$.

The thermal pad on the DLPA300 micromirror controller and the LM43601 step-down voltage converter are electrically connected to the $V_{\text{RESET_RAIL}}$. Furthermore, the AGND and PGND pins on the LM43601 step-down voltage converter are also connected to the $V_{\text{RESET_RAIL}}$. Therefore, the logic levels and analog voltage levels for LM43601 step-down voltage converter are referenced to the $-16.5\text{-V } V_{\text{RESET_RAIL}}$.

The LM43601 data sheet provides details for the component selection for the components in the voltage regulator circuit connected to the $V_{\text{RESET_RAIL}}$. The output of the regulator is set to the VRESET value of -16.5 V . The selection of the resistors in the resistor divider sets the output voltages, 6.49 k Ω and 100 k Ω .

The DLP780NE power sequencing requires that the VCC2 power supply ramps up after the 1.8-V supply is powered on and stable, and V_{OFFSET} is powered up and stable. The two conditions are met by the wired-or of the $\overline{\text{ERROR}}$ signal from the LP38513-1.8 ultra-low dropout linear regulator and an enable signal generated from V_{OFFSET} . The 2N7002 enhancement mode FET acts as an inverter and level shifter from V_{OFFSET} to a 3.3-V logic level.

In the event of a power supply failure (such as a pull-the-plug event), VCC2 must be driven low before the 1.8-V supply starts to drop voltage. To achieve this, the TPS3847 12-V voltage monitor triggers a shunt-to-ground power FET to pull VCC2 to ground.

8.2.2.1 Component Selection Guidelines

Table 8-1. 5-V Regulator

COMPONENT	VALUE	TYPE OR PART NUMBER	CONNECTION 1	CONNECTION 2
P12V filter capacitor	10 to 33 μF , 20 VDC, 1 Ω max ESR	Tantalum or ceramic	Positive Terminal: P12V, pin 11 (locate near pin 11)	Negative Terminal: Ground
P12V bypass capacitor	0.1 μF , 50 VDC, 0.1 Ω max ESR	Ceramic	P12V, pin 11 (locate near pin 11)	Ground
V5REG filter capacitor	0.1 ⁽¹⁾ to 1.0 μF , 10 VDC, 2.5 Ω max ESR	Tantalum or ceramic	Positive Terminal: V5REG, pin 47 (locate near pin 47)	Negative Terminal: Ground
V5REG bypass capacitor	0.1 μF ⁽¹⁾ , 16 VDC, 0.1 Ω max ESR	Ceramic	V5REG, pin 47 (locate near pin 47)	Ground

(1) To ensure stability of the linear regulator, use a capacitance with a value not less than 0.1 μF .

Table 8-2. Bias Voltage Boost Converter

COMPONENT	VALUE	TYPE OR PART NUMBER	CONNECTION 1	CONNECTION 2
LHI filter capacitor	10 μ F, 20 VDC, 1- Ω max ESR	Tantalum or ceramic	Positive Terminal: VBIAS_LHI, pin 10 (locate near pin 10)	Negative Terminal: Ground
LHI bypass capacitor	0.1 μ F, 50 VDC, 0.1- Ω max ESR	Ceramic	VBIAS_LHI, pin 10 (locate near pin 10)	Ground
VBIAS_RAIL filter capacitor (2 required)	1 μ F, 50 VDC, 0.1- Ω max ESR	Ceramic	VBIAS_RAIL, pins 30 and 71 (locate near pins 30 and 71)	Ground
VBIAS_RAIL bypass capacitors (2 required)	0.1 μ F, 50 VDC, 0.1 Ω max ESR	Ceramic	VBIAS_RAIL, pins 30 and 71 (locate near pins 30 and 71)	Ground
Inductor	22 μ H, 0.5 A, 160 m Ω ESR	Coil Craft DT1608C-223 (or equivalent)	VBIAS_LHI, pin 10	VBIAS_SWL, pin 8
Schottky diode	0.5 A, 40 V (minimum)	OnSemi MBR0540T1G or STMicroelectronics STPS0540Z, STPS0560Z (or equivalent)	Anode: VBIAS_SWL, pin 8	Cathode: VBIAS, pin 9

Table 8-3. Offset Voltage Regulator

COMPONENT	VALUE	TYPE OR PART NUMBER	CONNECTION 1	CONNECTION 2
VOFFSET filter capacitors	1 ⁽¹⁾ to 4.7 ⁽²⁾ μ F, 35 VDC, 1 Ω max ESR	Tantalum or ceramic	Positive Terminal: VOFFSET, pin 49 (1st Cap near pin 49) Positive Terminal: DMDVCC2 pins (2nd Cap at DMD)	Negative Terminal: Ground at DLPA300 Negative Terminal: VSS (Ground) at DMD
VOFFSET bypass capacitors (3 required)	0.1 μ F, 50 VDC, 0.1 Ω max ESR	Ceramic	VOFFSET, pin 49 (locate 1 near pin 49)	Ground at DLPA300 Ground at DMD
Zener Diode	11V 3W	Micro Commercial Components 3SMBJ5926B-TP or equivalent	VOFFSET	Ground

(1) To ensure stability of the linear regulator, the absolute minimum output capacitance must not be less than 1.0 μ F.

(2) Recommended value is 3.3 μ F each. Different values are acceptable, provided that the sum of the two is 6.8 μ F maximum.

Table 8-4. Pullup Resistors

COMPONENT	VALUE (k Ω)	TYPE OR PART NUMBER	CONNECTION 1	CONNECTION 2
Resistor	2.2		SCPDO, pin 42	Chipset controller 3.3-V V_{DD}
Resistor	2.2		\overline{IRQ} , pin 43	Chipset Controller 3.3-V V_{DD}
Resistor (optional)	2.2		\overline{OE} , pin 6	Chipset Controller 3.3-V V_{DD}

8.2.3 Application Curves

The power supply sequencing for V_{BIAS} , V_{OFFSET} and V_{RESET} are shown in [Figure 8-2](#) and [Figure 8-3](#). On power-up, the turn on of V_{BIAS} enables the external V_{RESET} voltage regulator. In power-down, when V_{BIAS} powers off, it disables the V_{RESET} regulator, which slowly decays to ground.

The power sequencing for V_{CC2} voltage regulator is shown in [Figure 8-4](#) and [Figure 8-5](#). The power up of V_{OFFSET} enables the turn on of the V_{CC2} voltage regulator. As seen in the zoom out of [Figure 8-4](#), the 1.8-V supply is already on and stable. Similarly, the power down of V_{OFFSET} disables the V_{CC2} voltage regulator. The 1.8-V supply powers down after both V_{OFFSET} and V_{CC2} are powered down, as seen in the zoom out of [Figure 8-5](#).

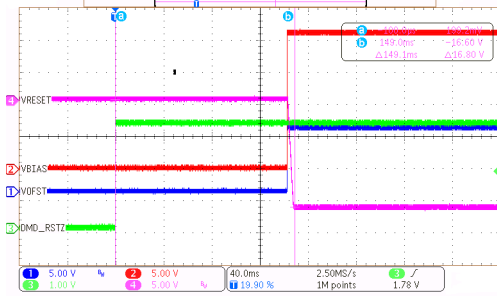

Figure 8-2. High Voltage Power-Up Sequence

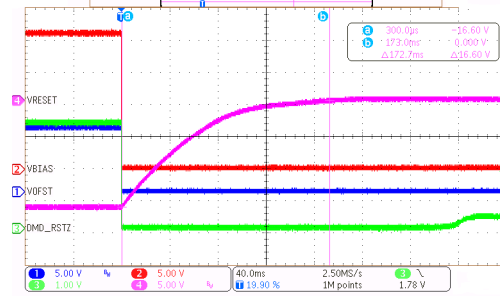

Figure 8-3. High Voltage Power-Down Sequence

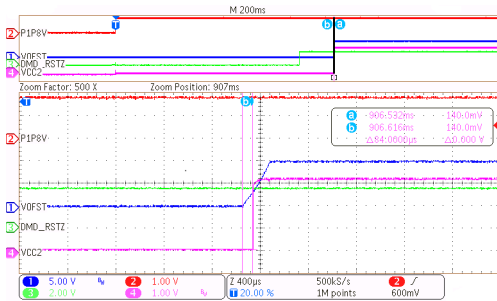

Figure 8-4. VCC2 Power-Up Sequence

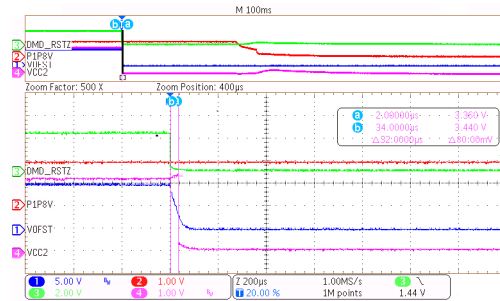

Figure 8-5. VCC2 Power-Down Sequence

9 Power Supply Recommendations

9.1 Power Supply Rail Guidelines

Table 8-1 through Table 8-4 provides discrete component selection guidelines.

- Ensure that the P12V filter and bypass capacitors are distributed and connected to pin 11 and pin 48 and pin 50. Place these capacitors as close to their respective pins as possible and if necessary, place on the bottom layer.
- The V5REG filter and bypass capacitors must be placed near and connected to pin 47.
- It is best to route the VBIAS_RAIL etch runs in the following order: pin 40, pin 31, pin 30, pin 21, pin 80, pin 71, pin 70, and pin 61. Ensure that the etch runs are short and direct as they must carry 35 ns current spikes of up to 0.64 A (peak). Locate the bypass capacitors near and connected to pin 30 and pin 71 to provide bypassing on both sides.
- The VBIAS_LHI filter and bypass capacitors must be placed near and connected to pin 10.
- The VBIAS filter and bypass capacitors must be placed near and connected to pin 9.
- VBIAS pin 9 must also be connected (optionally with a 0-ohm resistor) to VBIAS_RAIL at or between pins 21 and 80.
- Route the VRESET_RAIL etch runs in the following order: pin 36, pin 35, pin 26, pin 25, pin 76, pin 75, pin 66, and pin 65. Ensure the etch runs are short and direct as they must carry 35 ns current spikes of up to 0.64 A (peak). Bypass capacitors must be placed near and connected to pins 35 and 66 to provide bypassing on both sides.
- The VRESET filter and bypass capacitors must be located near and connected to pin 13. VRESET pin 13 must also be connected (optionally with a 0-Ω resistor) to VRESET_RAIL at or between pin 25 and pin 76.
- Route the VOFFSET_RAIL etch runs in the following order: pin 23, pin 28, pin 33, pin 38, pin 63, pin 68, pin 73, and pin 78. Ensure the etch runs are short and direct as they must carry 35 ns current spikes of up to 0.64 A (peak). Place the bypass capacitors near and connected to pin 28 and pin 73 to provide bypassing on both sides.
- The VOFFSET filter and bypass capacitors must be placed near and connected to pin 49.
- VOFFSET pin 49 must also be connected (optionally with a 0-Ω resistor) to VOFFSET_RAIL at or between pin 38 and pin 63.

Note

Aluminum electrolytic capacitors may not be suitable for the DLPA300 application. At the switching frequencies used in the DLPA300 (up to 1.5 MHz), aluminum electrolytic capacitors drop significantly in capacitance and increase in ESR resulting in voltage spikes on the power supply rails, which could cause the device to shut down or perform in an unreliable manner.

10 Layout

10.1 Layout Guidelines

CAUTION

Board layout and routing guidelines must be followed explicitly and all external components used must be in the range of values and of the quality recommended for proper operation of the DLPA300.

CAUTION

Thermal pads must be tied to VRESET_RAIL. Do not connect to ground.

Provide suitable Kelvin connections for the switching regulator feedback pins: V_{BIAS} (pin 9) and V_{RESET} (pin 13).

Make the PCB traces that connect the switching devices: V_{BIAS_SWL} (pin 8) and V_{RESET_SWL} (pin 12) as short and wide as possible to minimize leakage inductances. Make the PCB traces that connect the switching converter components (inductors, flywheel diodes and filtering capacitors) as short and wide as possible. Ensure that the electrical loops that these components form are as small and compact as possible, with the ground referenced components forming a star connection.

Due to the fast switching transitions appearing on the sixteen reset OUTx pins, it is recommended to keep these traces as short as possible. Also, to minimize potential cross-talk between outputs, it is advisable to maintain as much clearance between each of the output traces.

10.1.1 Grounding Guidelines

Ensure that the PWB has an internal ground plane that extends under the DLPA300. All nine ground pins (1, 7, 14, 20, 41, 46, 53, 55, and 60) must be connected to the ground plane using the shortest possible runs and vias. All filter and bypass capacitors must be placed near the pin being filtered or bypassed for the shortest possible runs to the part and to the ground plane.

10.2 Thermal Considerations

Thermally bond or solder the DLPA300 package to an external thermal pad on the PWB surface. The recommended dimensions of the thermal pad are 10 mm × 10 mm centered under the device. The metal bottom of the package is tied internally to the substrate at the VRESET_RAIL voltage level. Therefore, the thermal pad on the board must be isolated from any other extraneous circuit or ground and no circuit vias are allowed inside the pad area. Thermal pads are required on both sides of the PWB. Connect the thermal pads together through an array of 5 × 5 thermal vias, 0.5 mm in diameter.

Thermal pads and the thermal vias are connected to VRESET_RAIL and must be isolated from ground, or any other circuit.

Locate an internal P12V plane directly underneath the top layer and have an isolated area under the DLPA300. This isolated area must be a minimum of 20 cm² and connect to the thermal pad of the DLPA300 through the thermal vias. The potential of the isolated area is also at VRESET_RAIL. The internal ground plane must extend under the DLPA300 to help carry the heat away. Please refer to the PowerPAD Thermally Enhanced Package application report ([SLMA002](#)) for details on thermally efficient package design considerations.

Be careful to place the DLPA300 device away from local PWB hotspots. Heat generated from adjacent components may impact the DLPA300 thermal characteristics.

11 Device and Documentation Support

11.1 Third-Party Products Disclaimer

TI'S PUBLICATION OF INFORMATION REGARDING THIRD-PARTY PRODUCTS OR SERVICES DOES NOT CONSTITUTE AN ENDORSEMENT REGARDING THE SUITABILITY OF SUCH PRODUCTS OR SERVICES OR A WARRANTY, REPRESENTATION OR ENDORSEMENT OF SUCH PRODUCTS OR SERVICES, EITHER ALONE OR IN COMBINATION WITH ANY TI PRODUCT OR SERVICE.

11.2 Device Support

11.2.1 Device Nomenclature

The device marking consists of the fields shown in [Figure 11-1](#).

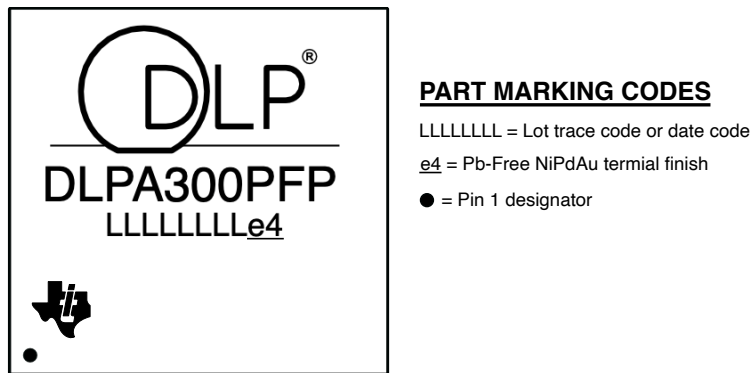

Figure 11-1. Device Marking (Device Top View)

11.3 Documentation Support

11.3.1 Related Documentation

The following documents contain additional information related to the chipsets supported by the DLPA300 micromirror driver and used in the typical application.

- [DLP780NE data sheet](#)
- [DLP800RE data sheet](#)
- [DLP780TE data sheet](#)
- [DLP781NE data sheet](#)
- [DLP801RE data sheet](#)
- [DLP781TE data sheet](#)
- [DLP801XE data sheet](#)
- [DLPC4430 data sheet](#)
- [DLPC4420 data sheet](#)
- [DLPA100 data sheet](#)
- [LM43601 data sheet](#)
- [LP38513S data sheet](#)
- [TPS73801 data sheet](#)
- [TPS3847085 data sheet](#)

11.4 Receiving Notification of Documentation Updates

To receive notification of documentation updates, navigate to the device product folder on ti.com. Click on *Subscribe to updates* to register and receive a weekly digest of any product information that has changed. For change details, review the revision history included in any revised document.

11.5 Support Resources

TI E2E™ [support forums](#) are an engineer's go-to source for fast, verified answers and design help — straight from the experts. Search existing answers or ask your own question to get the quick design help you need.

Linked content is provided "AS IS" by the respective contributors. They do not constitute TI specifications and do not necessarily reflect TI's views; see TI's [Terms of Use](#).

11.6 Trademarks

TI E2E™ is a trademark of Texas Instruments.

DLP® is a registered trademark of Texas Instruments.

All trademarks are the property of their respective owners.

11.7 Electrostatic Discharge Caution



This integrated circuit can be damaged by ESD. Texas Instruments recommends that all integrated circuits be handled with appropriate precautions. Failure to observe proper handling and installation procedures can cause damage.

ESD damage can range from subtle performance degradation to complete device failure. Precision integrated circuits may be more susceptible to damage because very small parametric changes could cause the device not to meet its published specifications.

11.8 Glossary

[TI Glossary](#) This glossary lists and explains terms, acronyms, and definitions.

12 Mechanical, Packaging, and Orderable Information

The following pages include mechanical, packaging, and orderable information. This information is the most current data available for the designated devices. This data is subject to change without notice and revision of this document. For browser-based versions of this data sheet, refer to the left-hand navigation.

MECHANICAL DATA

PFP (S-PQFP-G80)

PowerPAD™ PLASTIC QUAD FLATPACK

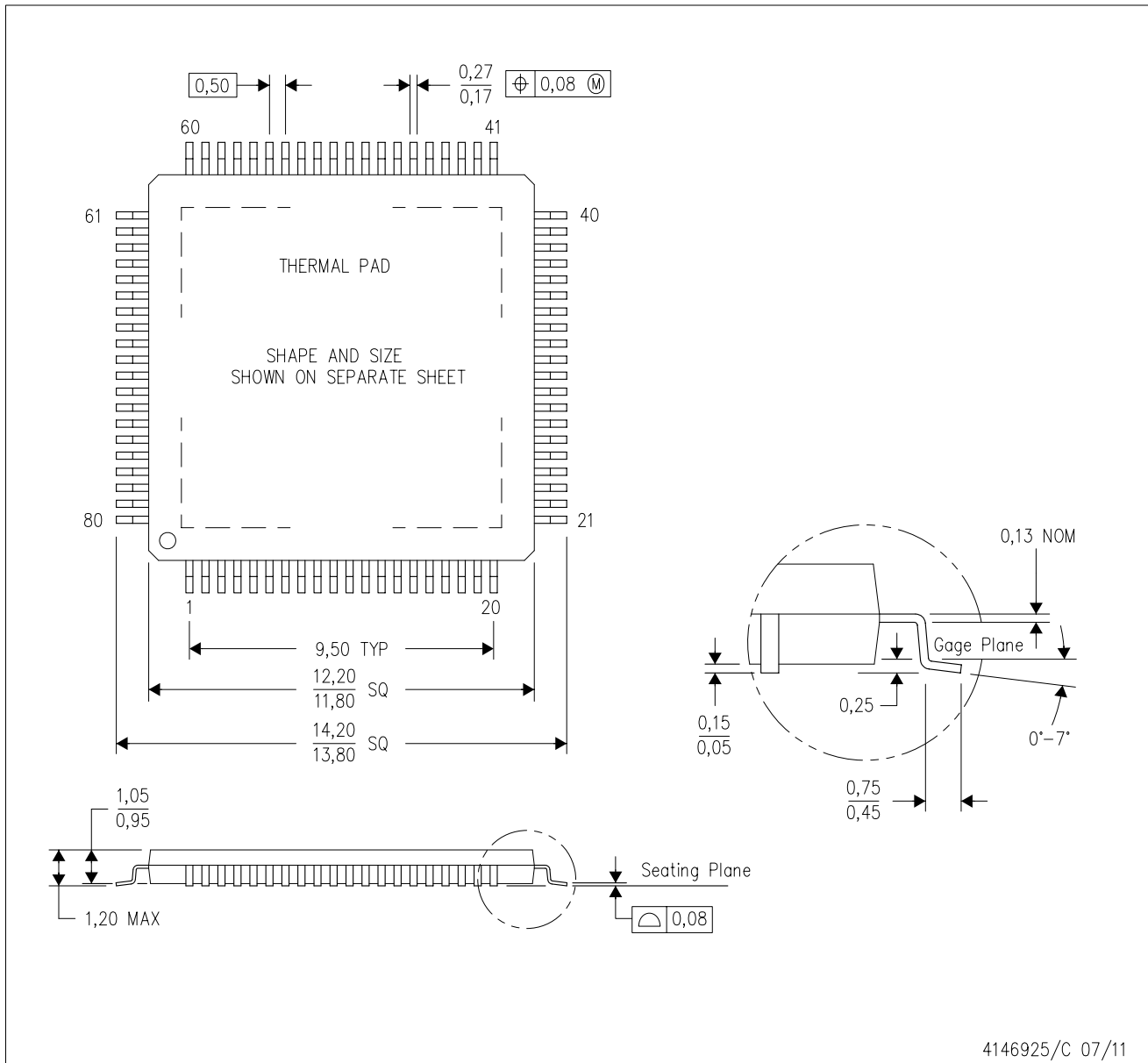

4146925/C 07/11

- NOTES:
- A. All linear dimensions are in millimeters.
 - B. This drawing is subject to change without notice.
 - C. Body dimensions do not include mold flash or protrusion
 - D. This package is designed to be soldered to a thermal pad on the board. Refer to Technical Brief, PowerPad Thermally Enhanced Package, Texas Instruments Literature No. SLMA002 for information regarding recommended board layout. This document is available at www.ti.com <<http://www.ti.com>>.
 - E. See the additional figure in the Product Data Sheet for details regarding the exposed thermal pad features and dimensions.
 - F. Falls within JEDEC MS-026

PowerPAD is a trademark of Texas Instruments.

THERMAL PAD MECHANICAL DATA

PFP (S-PQFP-G80)

PowerPAD™ PLASTIC QUAD FLATPACK

THERMAL INFORMATION

This PowerPAD™ package incorporates an exposed thermal pad that is designed to be attached to a printed circuit board (PCB). The thermal pad must be soldered directly to the PCB. After soldering, the PCB can be used as a heatsink. In addition, through the use of thermal vias, the thermal pad can be attached directly to the appropriate copper plane shown in the electrical schematic for the device, or alternatively, can be attached to a special heatsink structure designed into the PCB. This design optimizes the heat transfer from the integrated circuit (IC).

For additional information on the PowerPAD package and how to take advantage of its heat dissipating abilities, refer to Technical Brief, PowerPAD Thermally Enhanced Package, Texas Instruments Literature No. SLMA002 and Application Brief, PowerPAD Made Easy, Texas Instruments Literature No. SLMA004. Both documents are available at www.ti.com.

The exposed thermal pad dimensions for this package are shown in the following illustration.

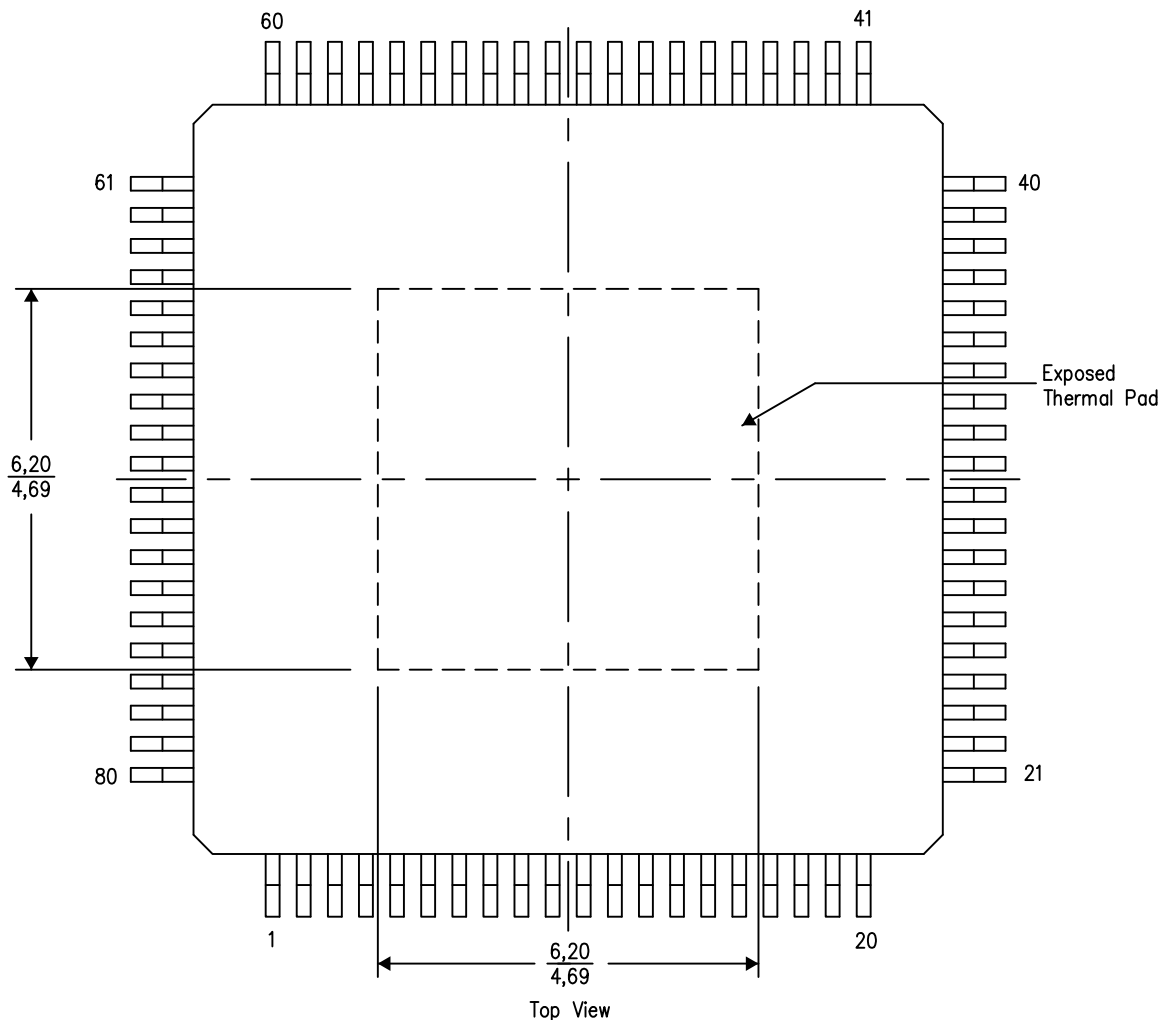

4206327-3/P 05/14

NOTE: A. All linear dimensions are in millimeters

PowerPAD is a trademark of Texas Instruments

LAND PATTERN DATA

PFP (S-PQFP-G80)

PowerPAD™ PLASTIC QUAD FLATPACK

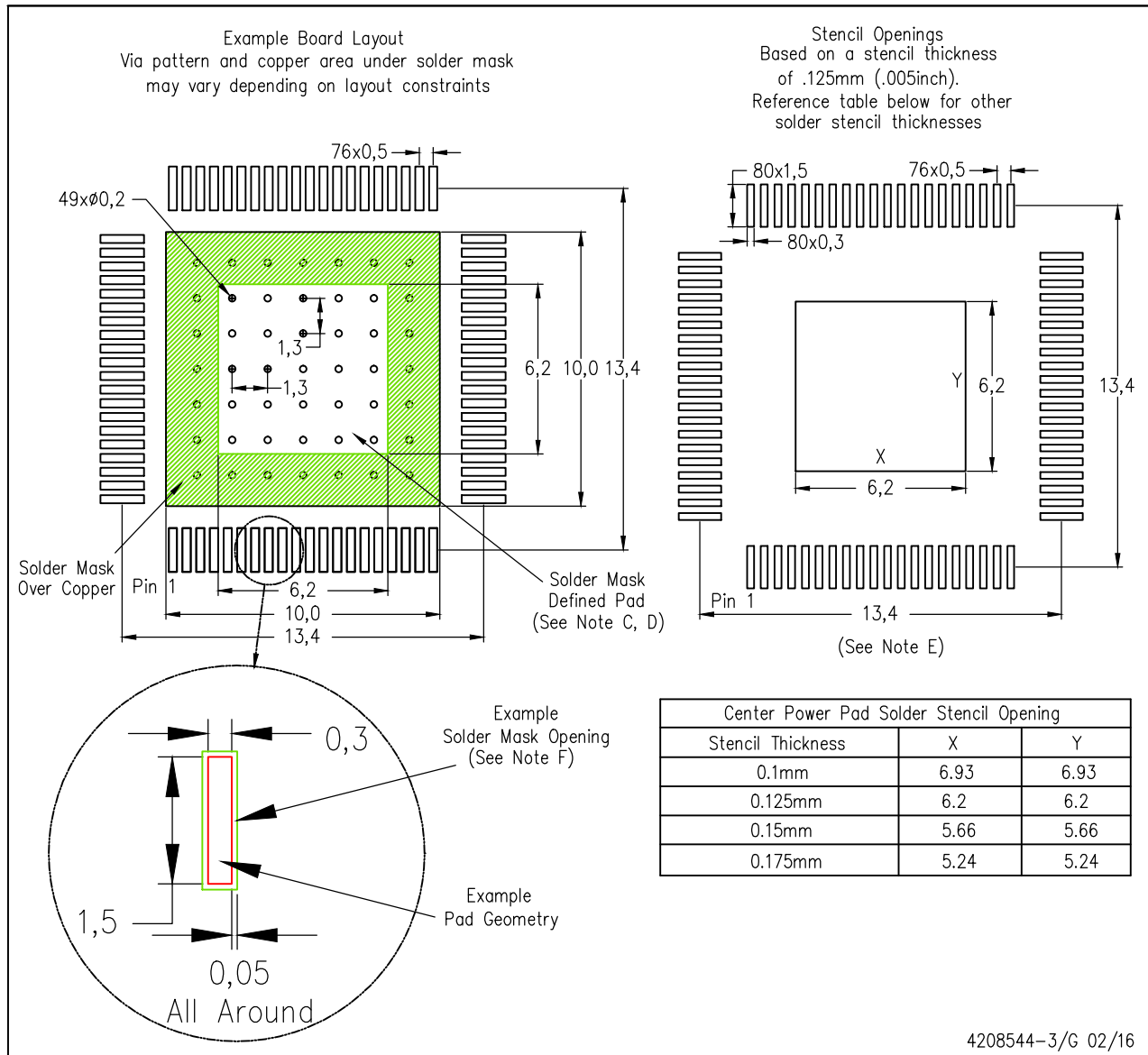

- NOTES:
- All linear dimensions are in millimeters.
 - This drawing is subject to change without notice.
 - Customers should place a note on the circuit board fabrication drawing not to alter the center solder mask defined pad.
 - This package is designed to be soldered to a thermal pad on the board. Refer to Technical Brief, PowerPad Thermally Enhanced Package, Texas Instruments Literature No. SLMA002, SLMA004, and also the Product Data Sheets for specific thermal information, via requirements, and recommended board layout. These documents are available at www.ti.com <<http://www.ti.com>>. Publication IPC-7351 is recommended for alternate designs.
 - Laser cutting apertures with trapezoidal walls and also rounding corners will offer better paste release. Customers should contact their board assembly site for stencil design recommendations. Example stencil design based on a 50% volumetric metal load solder paste. Refer to IPC-7525 for other stencil recommendations.
 - Customers should contact their board fabrication site for solder mask tolerances between and around signal pads.
- PowerPAD is a trademark of Texas Instruments.

PACKAGING INFORMATION

Orderable Device	Status (1)	Package Type	Package Drawing	Pins	Package Qty	Eco Plan (2)	Lead finish/ Ball material (6)	MSL Peak Temp (3)	Op Temp (°C)	Device Marking (4/5)	Samples
DLPA300PFP	ACTIVE	HTQFP	PFP	80	119	TBD	Call TI	Call TI	0 to 70		Samples

(1) The marketing status values are defined as follows:

ACTIVE: Product device recommended for new designs.

LIFEBUY: TI has announced that the device will be discontinued, and a lifetime-buy period is in effect.

NRND: Not recommended for new designs. Device is in production to support existing customers, but TI does not recommend using this part in a new design.

PREVIEW: Device has been announced but is not in production. Samples may or may not be available.

OBSELETE: TI has discontinued the production of the device.

(2) **RoHS:** TI defines "RoHS" to mean semiconductor products that are compliant with the current EU RoHS requirements for all 10 RoHS substances, including the requirement that RoHS substance do not exceed 0.1% by weight in homogeneous materials. Where designed to be soldered at high temperatures, "RoHS" products are suitable for use in specified lead-free processes. TI may reference these types of products as "Pb-Free".

RoHS Exempt: TI defines "RoHS Exempt" to mean products that contain lead but are compliant with EU RoHS pursuant to a specific EU RoHS exemption.

Green: TI defines "Green" to mean the content of Chlorine (Cl) and Bromine (Br) based flame retardants meet JS709B low halogen requirements of <=1000ppm threshold. Antimony trioxide based flame retardants must also meet the <=1000ppm threshold requirement.

(3) MSL, Peak Temp. - The Moisture Sensitivity Level rating according to the JEDEC industry standard classifications, and peak solder temperature.

(4) There may be additional marking, which relates to the logo, the lot trace code information, or the environmental category on the device.

(5) Multiple Device Markings will be inside parentheses. Only one Device Marking contained in parentheses and separated by a "~" will appear on a device. If a line is indented then it is a continuation of the previous line and the two combined represent the entire Device Marking for that device.

(6) Lead finish/Ball material - Orderable Devices may have multiple material finish options. Finish options are separated by a vertical ruled line. Lead finish/Ball material values may wrap to two lines if the finish value exceeds the maximum column width.

Important Information and Disclaimer:The information provided on this page represents TI's knowledge and belief as of the date that it is provided. TI bases its knowledge and belief on information provided by third parties, and makes no representation or warranty as to the accuracy of such information. Efforts are underway to better integrate information from third parties. TI has taken and continues to take reasonable steps to provide representative and accurate information but may not have conducted destructive testing or chemical analysis on incoming materials and chemicals. TI and TI suppliers consider certain information to be proprietary, and thus CAS numbers and other limited information may not be available for release.

In no event shall TI's liability arising out of such information exceed the total purchase price of the TI part(s) at issue in this document sold by TI to Customer on an annual basis.

PACKAGING INFORMATION

Orderable Device	Status (1)	Package Type	Package Drawing	Pins	Package Qty	Eco Plan (2)	Lead finish/ Ball material (6)	MSL Peak Temp (3)	Op Temp (°C)	Device Marking (4/5)	Samples
DLPA300PFP	ACTIVE	HTQFP	PFP	80	119	TBD	Call TI	Call TI	0 to 70		Samples

(1) The marketing status values are defined as follows:

ACTIVE: Product device recommended for new designs.

LIFEBUY: TI has announced that the device will be discontinued, and a lifetime-buy period is in effect.

NRND: Not recommended for new designs. Device is in production to support existing customers, but TI does not recommend using this part in a new design.

PREVIEW: Device has been announced but is not in production. Samples may or may not be available.

OBSELETE: TI has discontinued the production of the device.

(2) **RoHS:** TI defines "RoHS" to mean semiconductor products that are compliant with the current EU RoHS requirements for all 10 RoHS substances, including the requirement that RoHS substance do not exceed 0.1% by weight in homogeneous materials. Where designed to be soldered at high temperatures, "RoHS" products are suitable for use in specified lead-free processes. TI may reference these types of products as "Pb-Free".

RoHS Exempt: TI defines "RoHS Exempt" to mean products that contain lead but are compliant with EU RoHS pursuant to a specific EU RoHS exemption.

Green: TI defines "Green" to mean the content of Chlorine (Cl) and Bromine (Br) based flame retardants meet JS709B low halogen requirements of <=1000ppm threshold. Antimony trioxide based flame retardants must also meet the <=1000ppm threshold requirement.

(3) MSL, Peak Temp. - The Moisture Sensitivity Level rating according to the JEDEC industry standard classifications, and peak solder temperature.

(4) There may be additional marking, which relates to the logo, the lot trace code information, or the environmental category on the device.

(5) Multiple Device Markings will be inside parentheses. Only one Device Marking contained in parentheses and separated by a "~" will appear on a device. If a line is indented then it is a continuation of the previous line and the two combined represent the entire Device Marking for that device.

(6) Lead finish/Ball material - Orderable Devices may have multiple material finish options. Finish options are separated by a vertical ruled line. Lead finish/Ball material values may wrap to two lines if the finish value exceeds the maximum column width.

Important Information and Disclaimer:The information provided on this page represents TI's knowledge and belief as of the date that it is provided. TI bases its knowledge and belief on information provided by third parties, and makes no representation or warranty as to the accuracy of such information. Efforts are underway to better integrate information from third parties. TI has taken and continues to take reasonable steps to provide representative and accurate information but may not have conducted destructive testing or chemical analysis on incoming materials and chemicals. TI and TI suppliers consider certain information to be proprietary, and thus CAS numbers and other limited information may not be available for release.

In no event shall TI's liability arising out of such information exceed the total purchase price of the TI part(s) at issue in this document sold by TI to Customer on an annual basis.

IMPORTANT NOTICE AND DISCLAIMER

TI PROVIDES TECHNICAL AND RELIABILITY DATA (INCLUDING DATA SHEETS), DESIGN RESOURCES (INCLUDING REFERENCE DESIGNS), APPLICATION OR OTHER DESIGN ADVICE, WEB TOOLS, SAFETY INFORMATION, AND OTHER RESOURCES "AS IS" AND WITH ALL FAULTS, AND DISCLAIMS ALL WARRANTIES, EXPRESS AND IMPLIED, INCLUDING WITHOUT LIMITATION ANY IMPLIED WARRANTIES OF MERCHANTABILITY, FITNESS FOR A PARTICULAR PURPOSE OR NON-INFRINGEMENT OF THIRD PARTY INTELLECTUAL PROPERTY RIGHTS.

These resources are intended for skilled developers designing with TI products. You are solely responsible for (1) selecting the appropriate TI products for your application, (2) designing, validating and testing your application, and (3) ensuring your application meets applicable standards, and any other safety, security, regulatory or other requirements.

These resources are subject to change without notice. TI grants you permission to use these resources only for development of an application that uses the TI products described in the resource. Other reproduction and display of these resources is prohibited. No license is granted to any other TI intellectual property right or to any third party intellectual property right. TI disclaims responsibility for, and you will fully indemnify TI and its representatives against, any claims, damages, costs, losses, and liabilities arising out of your use of these resources.

TI's products are provided subject to [TI's Terms of Sale](#) or other applicable terms available either on [ti.com](https://www.ti.com) or provided in conjunction with such TI products. TI's provision of these resources does not expand or otherwise alter TI's applicable warranties or warranty disclaimers for TI products.

TI objects to and rejects any additional or different terms you may have proposed.

Mailing Address: Texas Instruments, Post Office Box 655303, Dallas, Texas 75265
Copyright © 2023, Texas Instruments Incorporated

Looking for pricing, stock, or lifecycle information?

Click below to explore more details on WIN SOURCE:

 [View DLPA300PFP](#) on WIN SOURCE

 [Texas Instruments](#) Information

Optimize Your Supply Chain with WIN SOURCE Solutions

-  Global Sourcing Solution
-  Obsolete Management
-  Cost Control Management
-  Shortage Management
-  Alternative Solution
-  Excess Inventory Management