



**THE DATASHEET OF
NCV2903VDR2G**



LM393, LM293, LM2903, LM2903V, NCV2903



ON Semiconductor®

<http://onsemi.com>

Low Offset Voltage Dual Comparators

The LM393 series are dual independent precision voltage comparators capable of single or split supply operation. These devices are designed to permit a common mode range-to-ground level with single supply operation. Input offset voltage specifications as low as 2.0 mV make this device an excellent selection for many applications in consumer, automotive, and industrial electronics.

Features

- Wide Single-Supply Range: 2.0 Vdc to 36 Vdc
- Split-Supply Range: ± 1.0 Vdc to ± 18 Vdc
- Very Low Current Drain Independent of Supply Voltage: 0.4 mA
- Low Input Bias Current: 25 nA
- Low Input Offset Current: 5.0 nA
- Low Input Offset Voltage: 5.0 mV (max) LM293/393
- Input Common Mode Range to Ground Level
- Differential Input Voltage Range Equal to Power Supply Voltage
- Output Voltage Compatible with DTL, ECL, TTL, MOS, and CMOS Logic Levels
- ESD Clamps on the Inputs Increase the Ruggedness of the Device without Affecting Performance
- NCV Prefix for Automotive and Other Applications Requiring Site and Control Changes
- Pb-Free Packages are Available

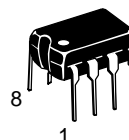

PDIP-8
N SUFFIX
CASE 626



SOIC-8
D SUFFIX
CASE 751



Micro8™
DM SUFFIX
CASE 846A

PIN CONNECTIONS

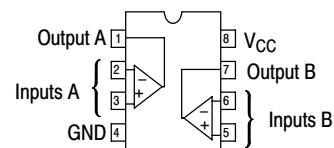

(Top View)

DEVICE MARKING AND ORDERING INFORMATION

See detailed marking information and ordering and shipping information on pages 6 and 7 of this data sheet.

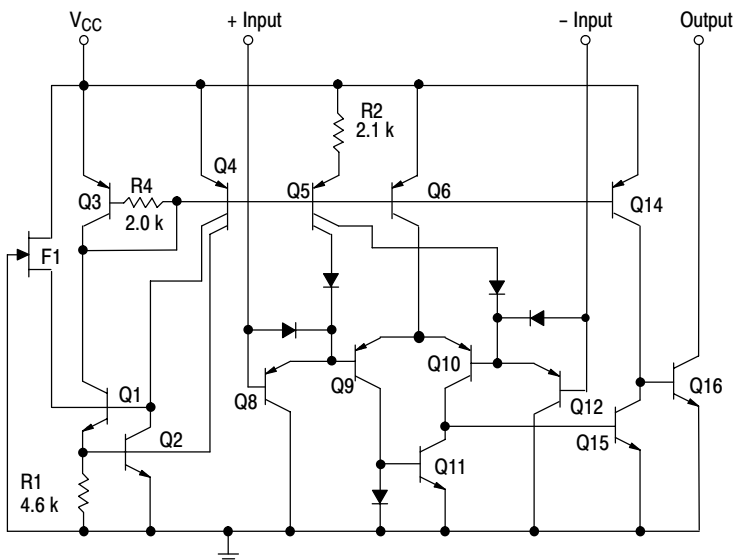

Figure 1. Representative Schematic Diagram

(Diagram shown is for 1 comparator)

LM393, LM293, LM2903, LM2903V, NCV2903

MAXIMUM RATINGS

Rating	Symbol	Value	Unit
Power Supply Voltage	V_{CC}	+36 or ± 18	Vdc
Input Differential Voltage Range	V_{IDR}	36	Vdc
Input Common Mode Voltage Range	V_{ICR}	-0.3 to +36	Vdc
Output Short Circuit-to-Ground Output Sink Current (Note 1)	I_{SC} I_{Sink}	Continuous 20	mA
Power Dissipation @ $T_A = 25^\circ\text{C}$ Derate above 25°C	P_D $1/R_{\theta JA}$	570 5.7	mW mW/ $^\circ\text{C}$
Operating Ambient Temperature Range LM293 LM393 LM2903 LM2903V, NCV2903 (Note 2)	T_A	-25 to +85 0 to +70 -40 to +105 -40 to +125	$^\circ\text{C}$
Maximum Operating Junction Temperature LM393, 2903, LM2903V LM293, NCV2903	$T_{J(max)}$	150 150	$^\circ\text{C}$
Storage Temperature Range	T_{stg}	-65 to +150	$^\circ\text{C}$
ESD Protection at any Pin (Note 3) – Human Body Model – Machine Model	V_{ESD}	1500 150	V

Maximum ratings are those values beyond which device damage can occur. Maximum ratings applied to the device are individual stress limit values (not normal operating conditions) and are not valid simultaneously. If these limits are exceeded, device functional operation is not implied, damage may occur and reliability may be affected.

1. The maximum output current may be as high as 20 mA, independent of the magnitude of V_{CC} , output short circuits to V_{CC} can cause excessive heating and eventual destruction.
2. *NCV2903 is qualified for automotive use.*
3. V_{ESD} rating for NCV/SC devices is: Human Body Model – 2000 V; Machine Model – 200 V.

LM393, LM293, LM2903, LM2903V, NCV2903

ELECTRICAL CHARACTERISTICS ($V_{CC} = 5.0$ Vdc, $T_{low} \leq T_A \leq T_{high}$, unless otherwise noted.)

Characteristic	Symbol	LM293, LM393			LM2903, LM2903V, NCV2903			Unit
		Min	Typ	Max	Min	Typ	Max	
Input Offset Voltage (Note 5) $T_A = 25^\circ\text{C}$ $T_{low} \leq T_A \leq T_{high}$	V_{IO}	–	± 1.0	± 5.0	–	± 2.0	± 7.0 15	mV
Input Offset Current $T_A = 25^\circ\text{C}$ $T_{low} \leq T_A \leq T_{high}$	I_{IO}	–	± 5.0	± 50	–	± 5.0	± 50 ± 200	nA
Input Bias Current (Note 6) $T_A = 25^\circ\text{C}$ $T_{low} \leq T_A \leq T_{high}$	I_{IB}	–	25	250	–	25	250 500	nA
Input Common Mode Voltage Range (Note 6) $T_A = 25^\circ\text{C}$ $T_{low} \leq T_A \leq T_{high}$	V_{ICR}	0 0	– –	$V_{CC} - 1.5$ $V_{CC} - 2.0$	0 0	– –	$V_{CC} - 1.5$ $V_{CC} - 2.0$	V
Voltage Gain $R_L \geq 15$ k Ω , $V_{CC} = 15$ Vdc, $T_A = 25^\circ\text{C}$	A_{VOL}	50	200	–	25	200	–	V/mV
Large Signal Response Time $V_{in} =$ TTL Logic Swing, $V_{ref} = 1.4$ Vdc $V_{RL} = 5.0$ Vdc, $R_L = 5.1$ k Ω , $T_A = 25^\circ\text{C}$	–	–	300	–	–	300	–	ns
Response Time (Note 8) $V_{RL} = 5.0$ Vdc, $R_L = 5.1$ k Ω , $T_A = 25^\circ\text{C}$	t_{TLH}	–	1.3	–	–	1.5	–	μs
Input Differential Voltage (Note 9) All $V_{in} \geq$ GND or V– Supply (if used)	V_{ID}	–	–	V_{CC}	–	–	V_{CC}	V
Output Sink Current $V_{in} \geq 1.0$ Vdc, $V_{in+} = 0$ Vdc, $V_O \leq 1.5$ Vdc $T_A = 25^\circ\text{C}$	I_{Sink}	6.0	16	–	6.0	16	–	mA
Output Saturation Voltage $V_{in} \geq 1.0$ Vdc, $V_{in+} = 0$, $I_{Sink} \leq 4.0$ mA, $T_A = 25^\circ\text{C}$ $T_{low} \leq T_A \leq T_{high}$	V_{OL}	– –	150 –	400 700	– –	– 200	400 700	mV
Output Leakage Current $V_{in-} = 0$ V, $V_{in+} \geq 1.0$ Vdc, $V_O = 5.0$ Vdc, $T_A = 25^\circ\text{C}$ $V_{in-} = 0$ V, $V_{in+} \geq 1.0$ Vdc, $V_O = 30$ Vdc, $T_{low} \leq T_A \leq T_{high}$	I_{OL}	– –	0.1 –	– 1000	– –	0.1 –	– 1000	nA
Supply Current $R_L = \infty$ Both Comparators, $T_A = 25^\circ\text{C}$ $R_L = \infty$ Both Comparators, $V_{CC} = 30$ V	I_{CC}	– –	0.4 –	1.0 2.5	– –	0.4 –	1.0 2.5	mA

LM293 $T_{low} = -25^\circ\text{C}$, $T_{high} = +85^\circ\text{C}$

LM393 $T_{low} = 0^\circ\text{C}$, $T_{high} = +70^\circ\text{C}$

LM2903 $T_{low} = -40^\circ\text{C}$, $T_{high} = +105^\circ\text{C}$

LM2903V & NCV2903 $T_{low} = -40^\circ\text{C}$, $T_{high} = +125^\circ\text{C}$

NCV2903 is qualified for automotive use.

4. The maximum output current may be as high as 20 mA, independent of the magnitude of V_{CC} , output short circuits to V_{CC} can cause excessive heating and eventual destruction.
5. At output switch point, $V_O \approx 1.4$ Vdc, $R_S = 0$ Ω with V_{CC} from 5.0 Vdc to 30 Vdc, and over the full input common mode range (0 V to $V_{CC} = -1.5$ V).
6. Due to the PNP transistor inputs, bias current will flow out of the inputs. This current is essentially constant, independent of the output state, therefore, no loading changes will exist on the input lines.
7. Input common mode of either input should not be permitted to go more than 0.3 V negative of ground or minus supply. The upper limit of common mode range is $V_{CC} - 1.5$ V.
8. Response time is specified with a 100 mV step and 5.0 mV of overdrive. With larger magnitudes of overdrive faster response times are obtainable.
9. The comparator will exhibit proper output state if one of the inputs becomes greater than V_{CC} , the other input must remain within the common mode range. The low input state must not be less than -0.3 V of ground or minus supply.

LM393, LM293, LM2903, LM2903V, NCV2903

LM293/393

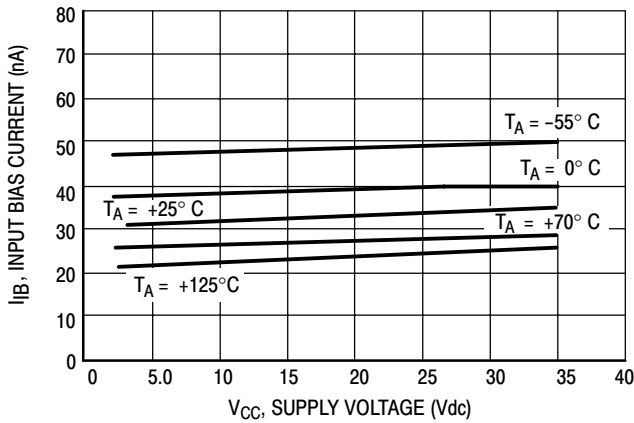

Figure 2. Input Bias Current versus Power Supply Voltage

LM2903

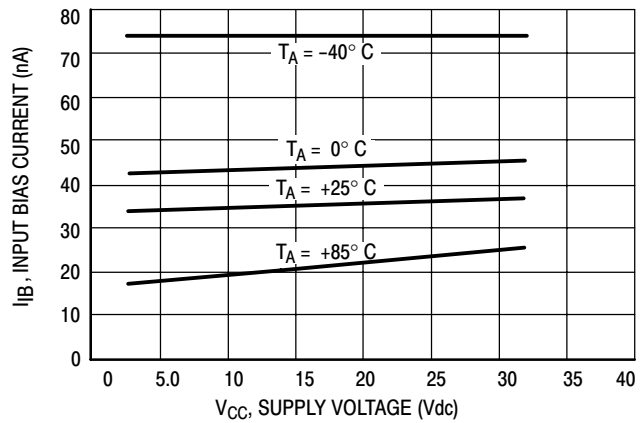

Figure 3. Input Bias Current versus Power Supply Voltage

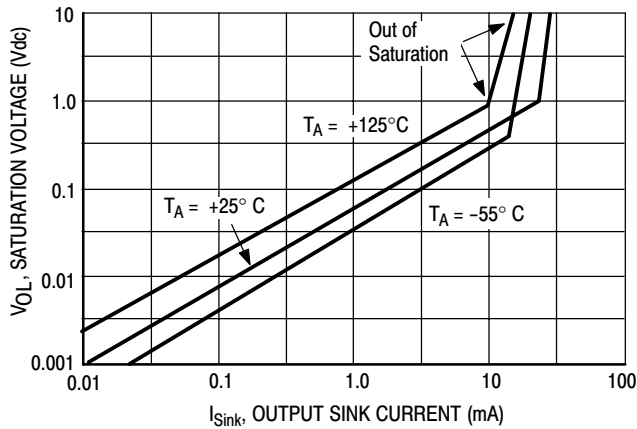

Figure 4. Output Saturation Voltage versus Output Sink Current

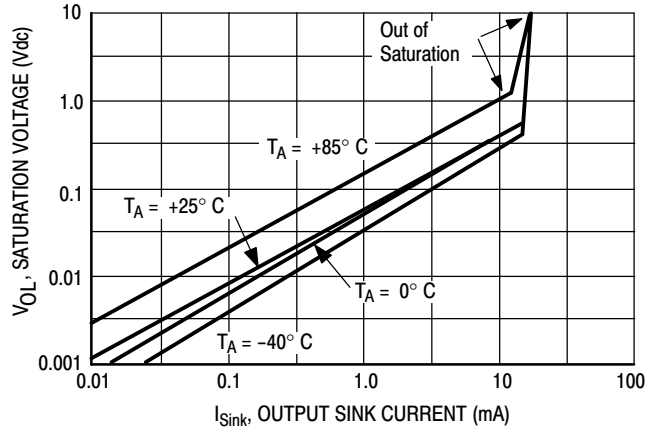

Figure 5. Output Saturation Voltage versus Output Sink Current

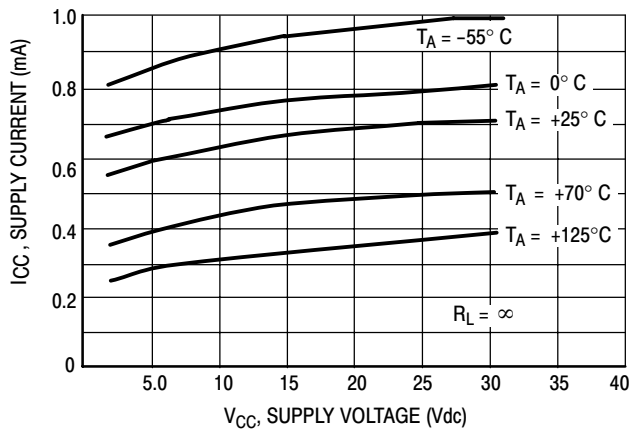

Figure 6. Power Supply Current versus Power Supply Voltage

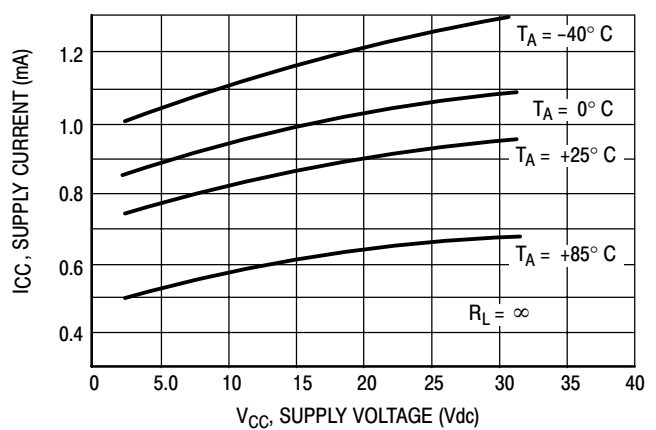

Figure 7. Power Supply Current versus Power Supply Voltage

APPLICATIONS INFORMATION

These dual comparators feature high gain, wide bandwidth characteristics. This gives the device oscillation tendencies if the outputs are capacitively coupled to the inputs via stray capacitance. This oscillation manifests itself during output transitions (V_{OL} to V_{OH}). To alleviate this situation, input resistors $< 10\text{ k}\Omega$ should be used.

The addition of positive feedback ($< 10\text{ mV}$) is also recommended. It is good design practice to ground all unused pins.

Differential input voltages may be larger than supply voltage without damaging the comparator's inputs. Voltages more negative than -0.3 V should not be used.

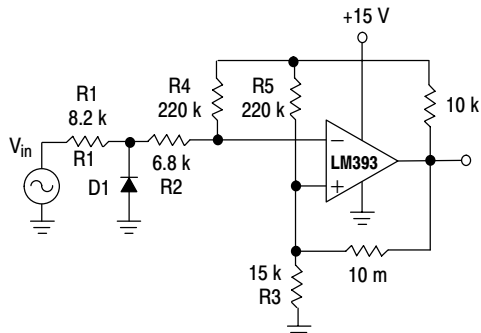

D1 prevents input from going negative by more than 0.6 V.

$$R1 + R2 = R3$$

$$R3 \leq \frac{R5}{10} \text{ for small error in zero crossing.}$$

Figure 8. Zero Crossing Detector (Single Supply)

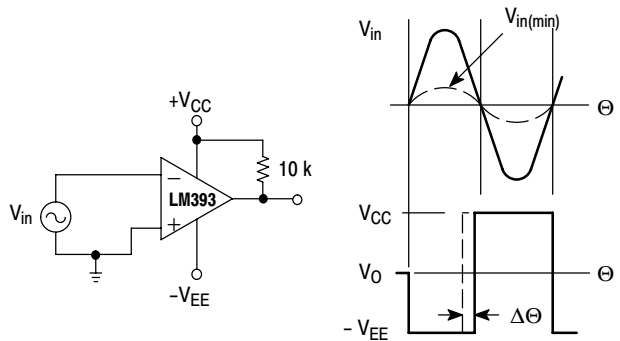

$$V_{in(min)} \approx 0.4\text{ V peak for } 1\% \text{ phase distortion } (\Delta\Theta).$$

Figure 9. Zero Crossing Detector (Split Supply)

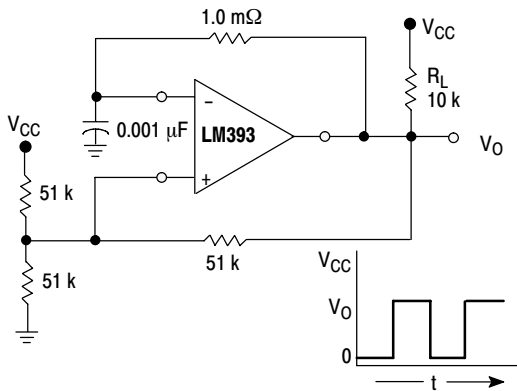
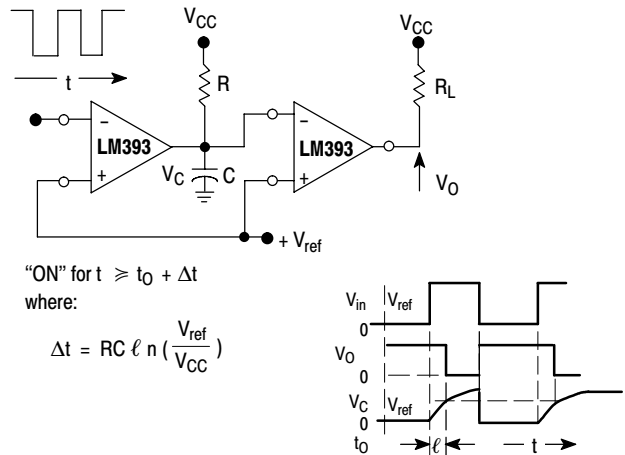

Figure 10. Free-Running Square-Wave Oscillator



"ON" for $t \geq t_0 + \Delta t$
where:

$$\Delta t = RC \ln \left(\frac{V_{ref}}{V_{CC}} \right)$$

Figure 11. Time Delay Generator

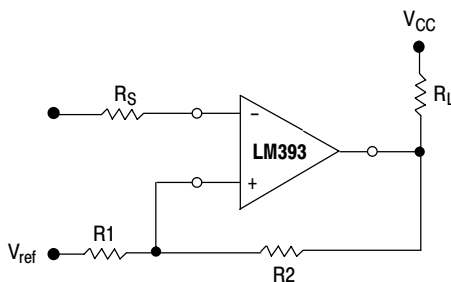

$$R_S = R1 \parallel R2$$

$$V_{th1} = V_{ref} + \frac{(V_{CC} - V_{ref}) R1}{R1 + R2 + R_L}$$

$$V_{th2} = V_{ref} - \frac{(V_{ref} - V_{O\text{ Low}}) R1}{R1 + R2}$$

Figure 12. Comparator with Hysteresis

LM393, LM293, LM2903, LM2903V, NCV2903

MARKING DIAGRAMS

PDIP-8
N SUFFIX
CASE 626

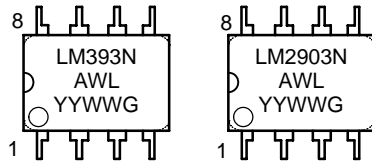

Micro8
DM SUFFIX
CASE 846A

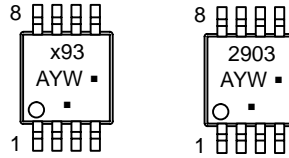

SOIC-8
D SUFFIX
CASE 751

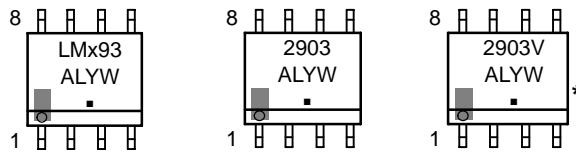

- x = 2 or 3
- A = Assembly Location
- WL, L = Wafer Lot
- YY, Y = Year
- WW, W = Work Week
- , G = Pb-Free Package

(Note: Microdot may be in either location)

*This marking diagram also applies to NCV2903DR2.

LM393, LM293, LM2903, LM2903V, NCV2903

ORDERING INFORMATION

Device	Package	Shipping†
LM293D	SOIC-8	98 Units / Rail
LM293DG	SOIC-8 (Pb-Free)	98 Units / Rail
LM293DR2	SOIC-8	2500 / Tape & Reel
LM293DR2G	SOIC-8 (Pb-Free)	2500 / Tape & Reel
LM293DMR2	Micro8	4000 / Tape and Reel
LM293DMR2G	Micro8 (Pb-Free)	4000 / Tape and Reel
LM393D	SOIC-8	98 Units / Rail
LM393DG	SOIC-8 (Pb-Free)	98 Units / Rail
LM393DR2	SOIC-8	2500 / Tape & Reel
LM393DR2G	SOIC-8 (Pb-Free)	2500 / Tape & Reel
LM393N	PDIP-8	50 Units / Rail
LM393NG	PDIP-8 (Pb-Free)	50 Units / Rail
LM393DMR2	Micro8	4000 / Tape and Reel
LM393DMR2G	Micro8 (Pb-Free)	4000 / Tape and Reel
LM2903D	SOIC-8	98 Units / Rail
LM2903DG	SOIC-8 (Pb-Free)	98 Units / Rail
LM2903DR2	SOIC-8	2500 / Tape & Reel
LM2903DR2G	SOIC-8 (Pb-Free)	2500 / Tape & Reel
LM2903N	PDIP-8	50 Units / Rail
LM2903NG	PDIP-8 (Pb-Free)	50 Units / Rail
LM2903DMR2	Micro8	4000 / Tape and Reel
LM2903DMR2G	Micro8 (Pb-Free)	4000 / Tape and Reel
LM2903VD	SOIC-8	98 Units / Rail
LM2903VDG	SOIC-8 (Pb-Free)	98 Units / Rail
LM2903VDR2	SOIC-8	2500 / Tape & Reel
LM2903VDR2G	SOIC-8 (Pb-Free)	2500 / Tape & Reel
LM2903VN	PDIP-8	50 Units / Rail
LM2903VNG	PDIP-8 (Pb-Free)	50 Units / Rail
NCV2903DR2 (Note 10)	SOIC-8	2500 / Tape & Reel
NCV2903DR2G (Note 10)	SOIC-8 (Pb-Free)	2500 / Tape & Reel
NCV2903DMR2 (Note 10)	Micro8	4000 / Tape & Reel
NCV2903DMR2G (Note 10)	Micro8 (Pb-Free)	4000 / Tape & Reel

†For information on tape and reel specifications, including part orientation and tape sizes, please refer to our Tape and Reel Packaging Specifications Brochure, BRD8011/D.

10. NCV2903 is qualified for automotive use.

LM393, LM293, LM2903, LM2903V, NCV2903

PACKAGE DIMENSIONS

PDIP-8
N SUFFIX
CASE 626-05
ISSUE L

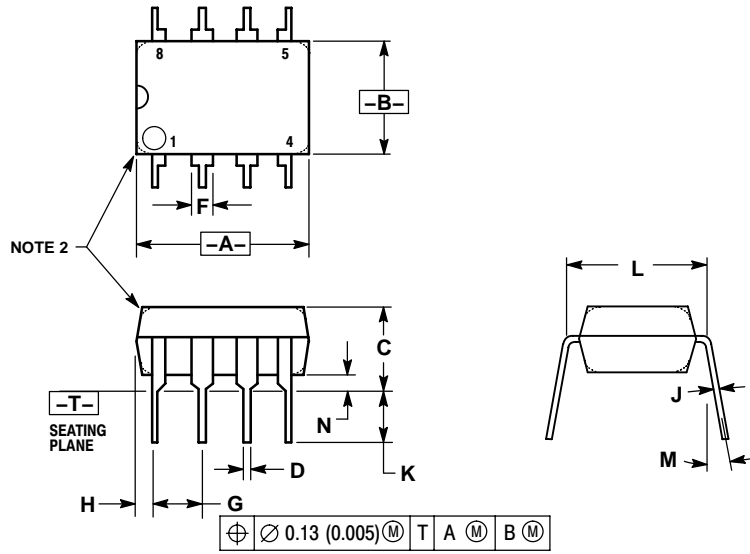

- NOTES:
1. DIMENSION L TO CENTER OF LEAD WHEN FORMED PARALLEL.
 2. PACKAGE CONTOUR OPTIONAL (ROUND OR SQUARE CORNERS).
 3. DIMENSIONING AND TOLERANCING PER ANSI Y14.5M, 1982.

DIM	MILLIMETERS		INCHES	
	MIN	MAX	MIN	MAX
A	9.40	10.16	0.370	0.400
B	6.10	6.60	0.240	0.260
C	3.94	4.45	0.155	0.175
D	0.38	0.51	0.015	0.020
F	1.02	1.78	0.040	0.070
G	2.54 BSC		0.100 BSC	
H	0.76	1.27	0.030	0.050
J	0.20	0.30	0.008	0.012
K	2.92	3.43	0.115	0.135
L	7.62 BSC		0.300 BSC	
M	---	10°	---	10°
N	0.76	1.01	0.030	0.040

LM393, LM293, LM2903, LM2903V, NCV2903

SOIC-8
D SUFFIX
CASE 751-07
ISSUE AG

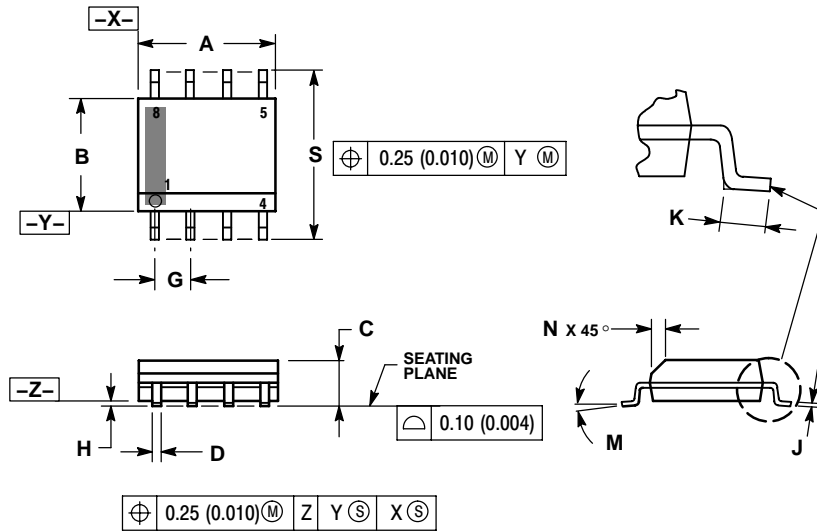

NOTES:

1. DIMENSIONING AND TOLERANCING PER ANSI Y14.5M, 1982.
2. CONTROLLING DIMENSION: MILLIMETER.
3. DIMENSION A AND B DO NOT INCLUDE MOLD PROTRUSION.
4. MAXIMUM MOLD PROTRUSION 0.15 (0.006) PER SIDE.
5. DIMENSION D DOES NOT INCLUDE DAMBAR PROTRUSION. ALLOWABLE DAMBAR PROTRUSION SHALL BE 0.127 (0.005) TOTAL IN EXCESS OF THE D DIMENSION AT MAXIMUM MATERIAL CONDITION.
6. 751-01 THRU 751-06 ARE OBSOLETE. NEW STANDARD IS 751-07.

DIM	MILLIMETERS		INCHES	
	MIN	MAX	MIN	MAX
A	4.80	5.00	0.189	0.197
B	3.80	4.00	0.150	0.157
C	1.35	1.75	0.053	0.069
D	0.33	0.51	0.013	0.020
G	1.27 BSC		0.050 BSC	
H	0.10	0.25	0.004	0.010
J	0.19	0.25	0.007	0.010
K	0.40	1.27	0.016	0.050
M	0°	8°	0°	8°
N	0.25	0.50	0.010	0.020
S	5.80	6.20	0.228	0.244

SOLDERING FOOTPRINT*

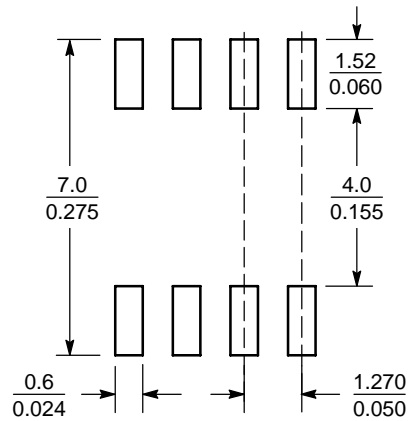

SCALE 6:1 (mm/inches)

*For additional information on our Pb-Free strategy and soldering details, please download the ON Semiconductor Soldering and Mounting Techniques Reference Manual, SOLDERRM/D.

LM393, LM293, LM2903, LM2903V, NCV2903

PACKAGE DIMENSIONS

Micro8
DM SUFFIX
CASE 846A-02
ISSUE G

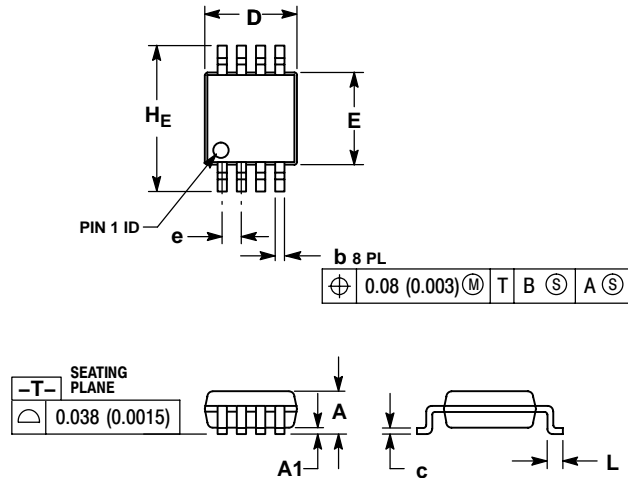

NOTES:

1. DIMENSIONING AND TOLERANCING PER ANSI Y14.5M, 1982.
2. CONTROLLING DIMENSION: MILLIMETER.
3. DIMENSION A DOES NOT INCLUDE MOLD FLASH, PROTRUSIONS OR GATE BURRS. MOLD FLASH, PROTRUSIONS OR GATE BURRS SHALL NOT EXCEED 0.15 (0.006) PER SIDE.
4. DIMENSION B DOES NOT INCLUDE INTERLEAD FLASH OR PROTRUSION. INTERLEAD FLASH OR PROTRUSION SHALL NOT EXCEED 0.25 (0.010) PER SIDE.
5. 846A-01 OBSOLETE, NEW STANDARD 846A-02.

DIM	MILLIMETERS			INCHES		
	MIN	NOM	MAX	MIN	NOM	MAX
A	---	---	1.10	---	---	0.043
A1	0.05	0.08	0.15	0.002	0.003	0.006
b	0.25	0.33	0.40	0.010	0.013	0.016
c	0.13	0.18	0.23	0.005	0.007	0.009
D	2.90	3.00	3.10	0.114	0.118	0.122
E	2.90	3.00	3.10	0.114	0.118	0.122
e	0.65 BSC			0.026 BSC		
L	0.40	0.55	0.70	0.016	0.021	0.028
HE	4.75	4.90	5.05	0.187	0.193	0.199

SOLDERING FOOTPRINT*

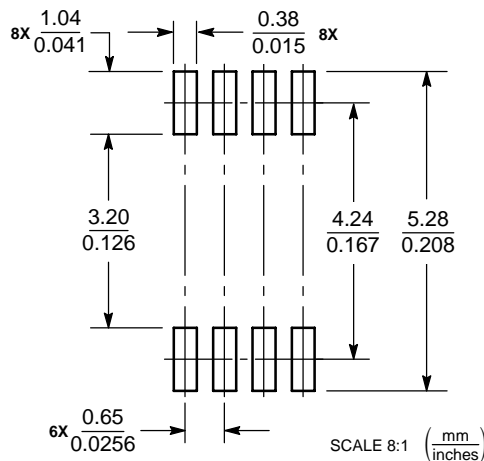

*For additional information on our Pb-Free strategy and soldering details, please download the ON Semiconductor Soldering and Mounting Techniques Reference Manual, SOLDERRM/D.

Micro8 is a trademark of International Rectifier.

ON Semiconductor and are registered trademarks of Semiconductor Components Industries, LLC (SCILLC). SCILLC reserves the right to make changes without further notice to any products herein. SCILLC makes no warranty, representation or guarantee regarding the suitability of its products for any particular purpose, nor does SCILLC assume any liability arising out of the application or use of any product or circuit, and specifically disclaims any and all liability, including without limitation special, consequential or incidental damages. "Typical" parameters which may be provided in SCILLC data sheets and/or specifications can and do vary in different applications and actual performance may vary over time. All operating parameters, including "Typicals" must be validated for each customer application by customer's technical experts. SCILLC does not convey any license under its patent rights nor the rights of others. SCILLC products are not designed, intended, or authorized for use as components in systems intended for surgical implant into the body, or other applications intended to support or sustain life, or for any other application in which the failure of the SCILLC product could create a situation where personal injury or death may occur. Should Buyer purchase or use SCILLC products for any such unintended or unauthorized application, Buyer shall indemnify and hold SCILLC and its officers, employees, subsidiaries, affiliates, and distributors harmless against all claims, costs, damages, and expenses, and reasonable attorney fees arising out of, directly or indirectly, any claim of personal injury or death associated with such unintended or unauthorized use, even if such claim alleges that SCILLC was negligent regarding the design or manufacture of the part. SCILLC is an Equal Opportunity/Affirmative Action Employer. This literature is subject to all applicable copyright laws and is not for resale in any manner.

PUBLICATION ORDERING INFORMATION

LITERATURE FULFILLMENT:
Literature Distribution Center for ON Semiconductor
P.O. Box 61312, Phoenix, Arizona 85082-1312 USA
Phone: 480-829-7710 or 800-344-3860 Toll Free USA/Canada
Fax: 480-829-7709 or 800-344-3867 Toll Free USA/Canada
Email: orderlit@onsemi.com

N. American Technical Support: 800-282-9855 Toll Free
USA/Canada

Japan: ON Semiconductor, Japan Customer Focus Center
2-9-1 Kamimeguro, meguro-ku, Tokyo, Japan 153-0051
Phone: 81-3-5773-3850

ON Semiconductor Website: <http://onsemi.com>

Order Literature: <http://www.onsemi.com/litorder>

For additional information, please contact your local Sales Representative.

Looking for pricing, stock, or lifecycle information?

Click below to explore more details on WIN SOURCE:

 [View NCV2903VDR2G on WIN SOURCE](#)

 [ON Semiconductor](#) Information

Optimize Your Supply Chain with WIN SOURCE Solutions

-  Global Sourcing Solution
-  Obsolete Management
-  Cost Control Management
-  Shortage Management
-  Alternative Solution
-  Excess Inventory Management