



THE DATASHEET OF CFPA-1FB4-A2T



CFPA

Surface Mount Pushbutton Switches

Washable

RoHS Compliant

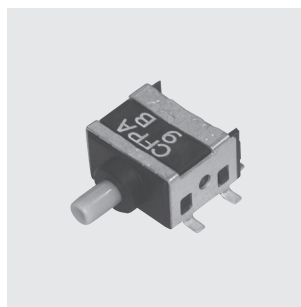

Features

1. Compatible with Reflow Soldering
2. Washable
3. Gold-Plated Contacts for Low Current Application
4. Clip Contact Mechanism for High Contact Reliability

Specifications

Rating	Max.	0.4 VA (28 VDC max.) (Resistive load)
	Min.	1 μ A 20 mVDC (Resistive load)
Initial contact resistance	80m Ω max. (1.5 mA 1 kHz 20mV min.)	
Dielectric strength	500 VAC 1 minute	
Initial insulation resistance	500 M Ω min. (500 VDC)	
Stroke	1.1 mm	
Operating force	1.5N \pm 1N	
Electrical life	50,000 operations at max. rating	
Switch timing	Non-shorting	
Operating temperature range	-40°C ~ +85°C	
Storage temperature range	-40°C ~ +85°C	

Part Numbering

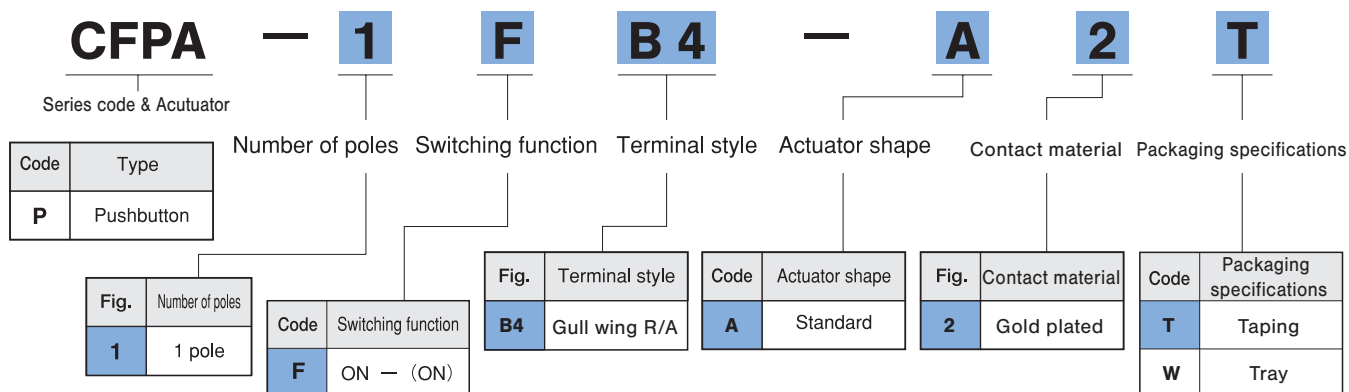

Optional Accessories

《Sold separately》

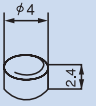

Part Name	Dimensions	Color	Part Number
Color Cap	Gloss finish  ABS resin	White	140000481453
		Red	140000481452
		Black	140000481451
		Gray	140000481450

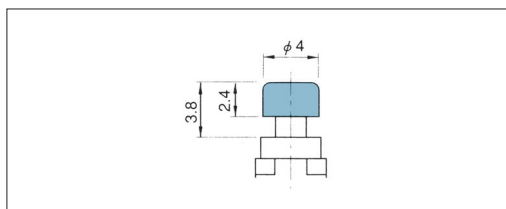
Color Cap Mounting



The color cap should be installed after the reflow soldering and washing process.

■ Switching function

Switching function		
Part No.	ON	(ON)
Connecting terminals	2-3	2-1

■ : Packing specifications T or W (ON) : Momentary

■ Pad Layouts

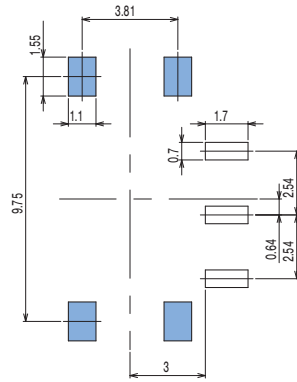

■ Dimension

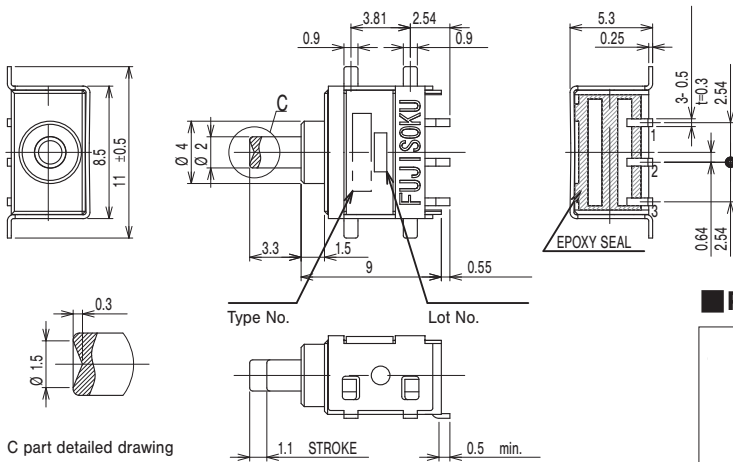

■ Table of Part Numbers

Packaging specifications	Part No.
Taping	CFPA-1FB4-A2T
Tray	CFPA-1FB4-A2W

■ Packaging Specifications

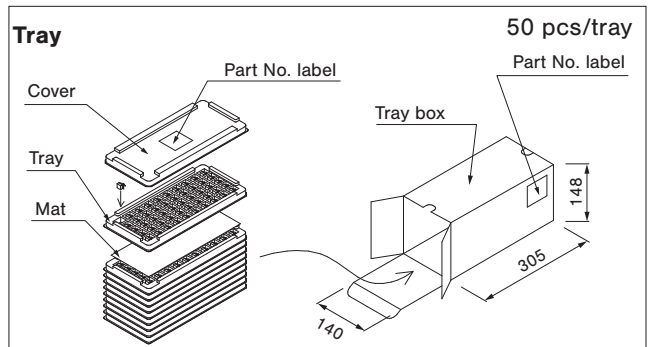
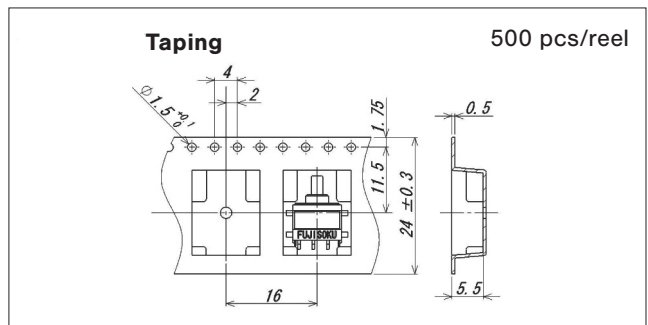

■ Soldering Specifications

(1) Reflow Soldering

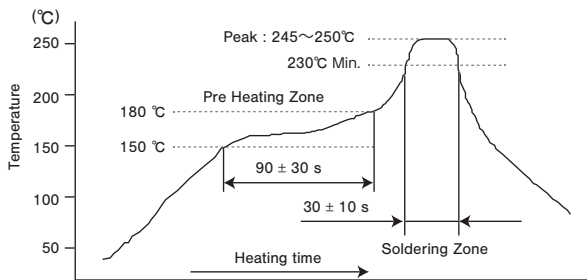

Apply reflow soldering: 2 times max.

(2) Manual Soldering

Device : Soldering iron
350°C, Max.; 3-4 seconds, Max.

■ Flux Cleaning

- (1) For the solvent, use water or alcohol. In addition, pay careful attention to use the solvent.
- (2) The cleaning method is limited to immersion cleaning only. The cleaning time is 2 minutes, max, but be sure to minimize the time as much as possible.
- (3) To clean the switch after soldering, wait until the switch temperature has cooled down to room temperature (30°C or below).
- (4) The product must be dried sufficiently after cleaning. Improper drying may result in fluctuation in torque or electrical damage.

Looking for pricing, stock, or lifecycle information?

Click below to explore more details on WIN SOURCE:

- ⊖ [View CFPA-1FB4-A2T on WIN SOURCE](#)
- ⊖ [Nidec Copal Electronics Information](#)

Optimize Your Supply Chain with WIN SOURCE Solutions

- ✓ Global Sourcing Solution
- ✓ Obsolete Management
- ✓ Cost Control Management
- ✓ Shortage Management
- ✓ Alternative Solution
- ✓ Excess Inventory Management