



THE DATASHEET OF TSY-13LNB+



Wideband

Monolithic Amplifier

TSY-13LNB+

50Ω 0.03 to 1 GHz



2mm x 2mm

The Big Deal

- Very wideband, 30 MHz – 1 GHz
- Low NF over entire frequency band, 1.2 dB
- Low current and low voltage (2.7V and 7.7 mA)
- Internal bypass switching

Product Overview

TSY-13LNB+ (RoHS compliant) is an advanced Low Voltage, Low Current, Low Noise wideband Bypass amplifier fabricated using GaAs E-PHEMT technology offering extremely high dynamic range over a broad frequency range. It has integrated switches enabling users to bypass the amplifier. TSY is enclosed in a 8-lead 2 x 2 mm MCLP package for good thermal performance.

Key Features

Feature	Advantages
Ultra-wideband: 30 MHz – 1 GHz	Ideal for a wide range of receiver applications including military, commercial wireless, and instrumentation.
Low Voltage & Low Current 2.7V & 7.7 mA	Ideal for Battery operated systems
High IP3 26.4 dBm typ at 0.5 GHz	Provides enhanced linearity over broad frequency range under high signal conditions.
Bypass feature Low insertion loss	Unlike other amplifiers, insertion loss is low in Bypass mode. (For Bypass, both V_{DD} and V_e are set to 0V.)
Compact size: 2 x 2 x 1 mm	Saves space in dense system layouts. Low inductance, repeatable transitions, and excellent thermal contact.



Wideband

Monolithic Amplifier

TSY-13LNB+

50Ω 0.03 to 1 GHz

Product Features

- Wideband: 0.03-1 GHz
- Built-in Bypass switching
- Low Noise figure: 1.2 dB typ.
- P1dB: +17.1 dBm typ.
- Low current and low voltage (2.7V and 7.7 mA)



Generic photo used for illustration purposes only

CASE STYLE: MC1631-1

+RoHS Compliant

The +Suffix identifies RoHS Compliance. See our web site for RoHS Compliance methodologies and qualifications

Typical Applications

- Wireless Base Station Systems
- Test and Measurement Systems
- Multi-Band Receivers

General Description

TSY-13LNB+(RoHS compliant) is an advanced Low Voltage, Low Current, Low Noise wideband Bypass amplifier fabricated using GaAs E-PHEMT technology offering extremely high dynamic range over a broad frequency range. It has integrated switches enabling users to bypass the amplifier. TSY is enclosed in a 8-lead 2 x 2 mm MCLP package for good thermal performance.

simplified schematic & pad description

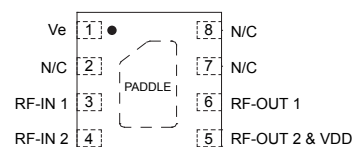
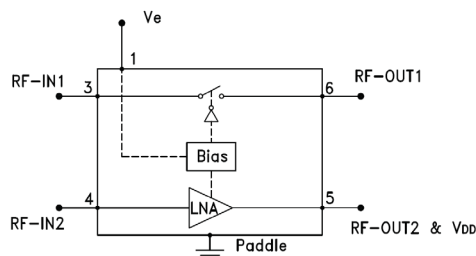

Function	Pad Number	Description (See Figure 1)
RF-IN 1 & RF-IN 2	3,4	RF-Input pads. Pad 4 is connected to Pad 3 via two 0.1μF Capacitors
RF-OUT 1 & RF-OUT2 & VDD	5,6	RF-Output pads. Pad 6 is connected to Pad 5 via 0.1μF Capacitor.
Voltage Enable (Ve)	1	Enable Voltage pad. Ve is always connected to V _{DD} . For amplifier bypass, V _{DD} & Ve should be turned OFF simultaneously.
Ground	Paddle	Connect to ground. Use via holes as shown in "Suggested Layout for PCB Design" to reduce ground path inductance for best performance.
N/C	2,7,8	No connection

Electrical Specifications¹ at 25°C, Zo=50Ω & V_{DD}=2.7V unless otherwise noted

Parameter	Condition (GHz)	Amplifier - ON			Amplifier - Bypass	Units
		Min.	Typ.	Max.	Typ.	
Frequency Range		0.03		1	0.03 - 1	GHz
Noise Figure	0.03		1.3		0.5	dB
	0.3		1.2		0.6	
	0.5		1.2		0.8	
	0.8		1.4		1.8	
	1.0		1.4		1.9	
Gain	0.03	—	15.3	—	-0.5	dB
	0.3	—	15.1	—	-0.6	
	0.5	13.3	14.7	16.3	-0.8	
	0.8	—	13.9	—	-1.8	
	1.0	—	13.1	—	-1.9	
Input Return Loss	0.03		13		19	dB
	0.3		14		19	
	0.5		14		14	
	0.8		11		10	
	1.0		10		8	
Output Return Loss	0.03		16		18	dB
	0.3		20		18	
	0.5		18		13	
	0.8		16		9	
	1.0		14		7	
Output Power at 1dB Compression, AMP-ON ²	0.03		15.9		1.2	dBm
	0.3		16.8		2.6	
	0.5		17.1		2.7	
	0.8		17.3		1.9	
	1.0		17.6		3.1	
Output IP ₃ ³	0.03		25.6		24.9	dBm
	0.3		27.5		27.6	
	0.5		26.4		28.4	
	0.8		27.8		26.9	
	1.0		24.7		30.4	
Device Operating Voltage (V _{DD}) ⁵		2.5	2.7	2.9	0	V
Device Operating Current (I _{D+I_e})		—	7.7	10.6	0	mA
Enable Voltage (V _e) ⁵		2.5	2.7	2.9	0	V
Device Current Variation vs. Temperature ⁴			1.5		—	μA/°C
Device Current Variation vs. Voltage			0.0067		—	mA/mV
Thermal Resistance, junction-to-ground lead			229		—	°C/W

1. Measured on Mini-Circuits Characterization Test Board TB-943-13LNB+. See Characterization Test Circuit (Fig. 1)
2. Current increases to 28-54 mA typ. at P1dB
3. Tested at P_{out}=+6 dBm/tone
4. ((Current at 85°C - Current at -45°C)/130)
5. V_{DD} is always connected to V_e

Absolute Maximum Ratings⁶

Parameter	Ratings
Operating Temperature (ground lead)	-40°C to 85°C
Storage Temperature	-65°C to 150°C
Total Power Dissipation	0.2W
Input Power	Amplifier - ON 10 dBm (continuous), +23 dBm (5 min. max)
	Amplifier Bypass 15 dBm (continuous), +22 dBm (5 min. max)
DC Voltage V _{DD} (Pad 5)	6V
DC Voltage V _e (Pad 1)	6V

	Min.	Typ.	Max.	Units
Amplifier-ON (V _{DD} , V _e)	2.5	2.7	2.9	V
Amplifier-Bypass (V _{DD} , V _e)	—	—	0.3	

6. Permanent damage may occur if any of these limits are exceeded.
Electrical maximum ratings are not intended for continuous normal operation.

Switching Specifications

Parameter		Min.	Typ.	Max.	Units
Amplifier ON to Bypass	OFF TIME (50% Control to 10% RF)	—	6	—	μS
	FALL TIME (90 TO 10% RF)	—	7	—	
Amplifier Bypass to ON	ON TIME (50% Control to 90% RF)	—	59	—	μS
	RISE TIME (10% to 90% RF)	—	20	—	
Control Voltage Leakage		—	443	—	mV

Characterization Test Circuit

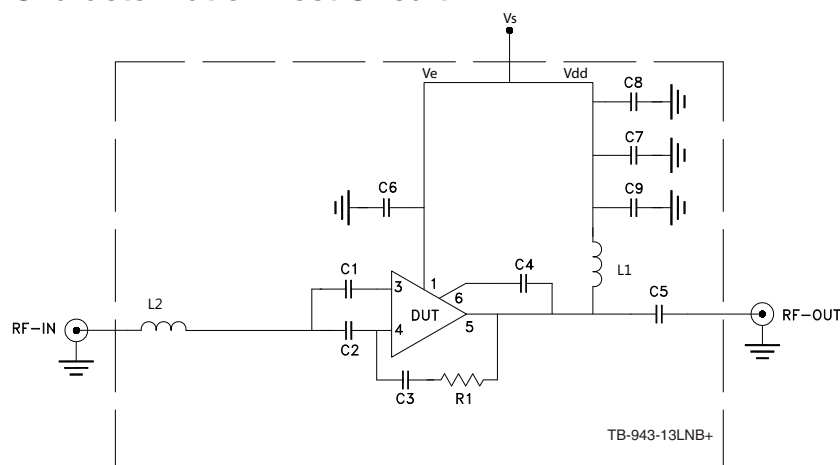

Component	P/N	Supplier	Value	Size
L1	1008CS-102XJLC	Coilcraft	1uH	0.115" x 0.11"
L2	LQG15HS3N0S02D	Murata	3nH	0402
C1 to C8	GRM155R71C104KA88D	Murata	0.1uF	0402
C9	GRM1555C1H102JA01D	Murata	1000pF	0402
R1	RK73H1ETTP4320F	KOA	432 Ω	0402

Fig 1. Block Diagram of Test Circuit used for characterization. (DUT soldered on Mini-Circuits Characterization test board TB-943-13LNB+) Gain, Return loss, Output power at 1dB compression (P1dB), output IP3 (OIP3) and noise figure measured using Agilent’s N5242A PNA-X microwave network analyzer.

Conditions:

1. Gain and Return loss: Pin= -25dBm
2. Output IP3 (OIP3): Two tones, spaced 1 MHz apart, +6 dBm/tone at output.
3. Switching Time RF Signal: Pin=-10 dBm at 500 MHz. V_{DD}=V_e=0 to 2.5 / 2.7 / 2.9V, Pulse Signal=500 Hz, 50% duty cycle.

Product Marking

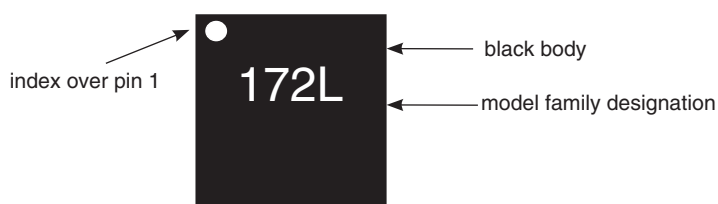

Additional Detailed Technical Information <i>additional information is available on our dash board. To access this information click here</i>	
Performance Data	Data Table
	Swept Graphs
	S-Parameter (S2P Files) Data Set (.zip file)
Case Style	MC1631-1 <i>Plastic package, exposed paddle, lead finish: matte-tin</i>
Tape & Reel Standard quantities available on reel	F66 <i>7" reels with 20, 50, 100, 200, 500, 1K or 2K devices</i>
Suggested Layout for PCB Design	PL-536
Evaluation Board	TB-943-13LNB+
Environmental Ratings	ENV08T1

ESD Rating

Human Body Model (HBM): Class 1A (Pass 250) in accordance with ANSI/ESD STM 5.1 - 2001 Machine.

MSL Rating

Moisture Sensitivity: MSL1 in accordance with IPC/JEDEC J-STD-020D

MSL Test Flow Chart

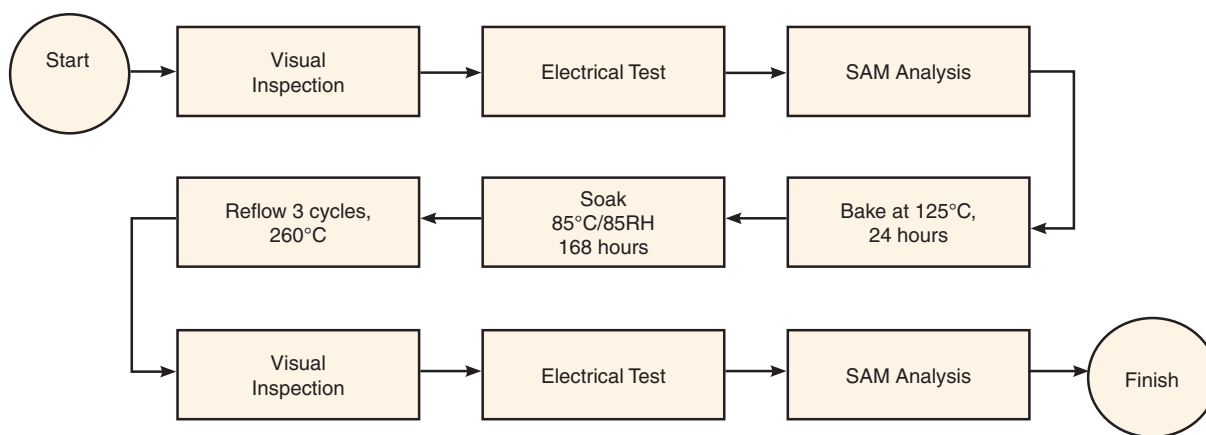

Additional Notes

- A. Performance and quality attributes and conditions not expressly stated in this specification document are intended to be excluded and do not form a part of this specification document.
- B. Electrical specifications and performance data contained in this specification document are based on Mini-Circuit's applicable established test performance criteria and measurement instructions.
- C. The parts covered by this specification document are subject to Mini-Circuits standard limited warranty and terms and conditions (collectively, "Standard Terms"); Purchasers of this part are entitled to the rights and benefits contained therein. For a full statement of the Standard Terms and the exclusive rights and remedies thereunder, please visit Mini-Circuits' website at www.minicircuits.com/MCLStore/terms.jsp



Looking for pricing, stock, or lifecycle information?

Click below to explore more details on WIN SOURCE:

 [View TSY-13LNB+ on WIN SOURCE](#)

 [Mini-Circuits Information](#)

Optimize Your Supply Chain with WIN SOURCE Solutions

-  Global Sourcing Solution
-  Obsolete Management
-  Cost Control Management
-  Shortage Management
-  Alternative Solution
-  Excess Inventory Management