



**THE DATASHEET OF  
RR121-1B13-311**



## 1 Description

The RedRock™ RR121 Series is a magnetic sensor with digital push-pull output ideal for use in medical, industrial, automotive, and consumer applications. Based on patented Tunneling Magnetoresistance (TMR) technology with seamless CMOS integration, the RR121 offers multiple configurations of several parameters to enable applications like proximity sensing, rotary sensing, and level detection.

The RR121 features available operate sensitivities from 9 G (0.9 mT) to 70 G (7 mT), and either omnipolar, unipolar, or bipolar magnetic field response. It has the world's lowest average current drain (200 nA) for an active magnetic sensor, as well as operating frequencies up to 10 kHz and high operating temperature ranges from -40°C up to 125°C.

### Device Information

Part Series	Package	Body Size (mm)
RR121	SOT-23-3	2.9 x 1.6 x 1.2
	LGA-4	1.4 x 1.4 x 0.45
	Leaded LGA-4	1.4 x 1.4 x 0.45

## 2 Features

- ▶ Operate sensitivity from 9 G to 70 G
- ▶ Lowest Average Current < 200 nA
- ▶ Omnipolar, Unipolar and Bipolar Latching Responses Available
- ▶ Operating Frequencies up to 10 kHz
- ▶ Temperature Rated up to 125°C
- ▶ RoHS & REACH Compliant

## 3 Applications

- ▶ Proximity Detection
- ▶ Rotary Sensing
- ▶ Fluid Level Detection
- ▶ Door & Lid Closure Detection
- ▶ Utility Meters
- ▶ Portable Medical Devices
- ▶ Motor Controllers
- ▶ Consumer Electronics
- ▶ Wake-Up  $\mu$ Processor

### Device Packages



**Please note: This Product Series is approaching end of life and is NOT recommended for new designs. For new designs, please consult the [end of life announcement](#) which specifies recommended new RedRock series replacements.**

### Functional Block Diagram

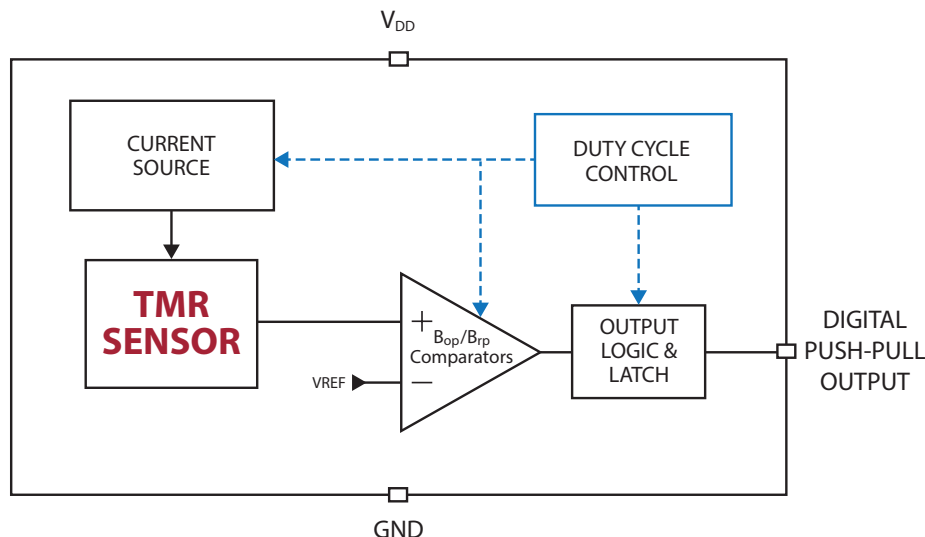

**Table of Contents**

1. Description ..... 1

2. Features ..... 1

3. Applications ..... 1

4. Specifications for all RR121 Series Sensors ..... 4

    4.1 Absolute Environmental Ratings for all RR121 Series Sensors ..... 4

    4.2 Absolute Electrical Ratings for all RR121 Series Sensors ..... 4

    4.3 Operating Electrical Characteristics for all RR121 Series Sensors ..... 4

5. Operating Characteristics for RR121-1B13-311 and RR121-1B13-312 ..... 5

6. Operating Characteristics for RR121-1A23-311 ..... 5

7. Operating Characteristics for RR121-1F23-311 - **OBSOLETE** ..... 6

8. Operating Characteristics for RR121-1B53-311 ..... 6

9. Operating Characteristics for RR121-1A53-311 ..... 7

10. Operating Characteristics for RR121-1E73-311 ..... 7

11. Operating Characteristics for RR121-1B93-312 ..... 7

12. Operating Characteristics for RR121-2A32-364 ..... 8

13. Operating Characteristics for RR121-3C63-311 ..... 8

14. Operating Characteristics for RR121-3C73-311 ..... 8

15. Operate & Release Lobe Plots ..... 9

    15.1 RR121-1B13-311 ..... 9

    15.2 RR121-1B13-312 ..... 9

    15.3 RR121-1A23-311 ..... 9

    15.4 RR121-1B53-311 ..... 9

16. Graphs - Typical Electrical Characteristics ..... 10

    16.1 RR121-1B13-311 & RR121-1B13-312 Average Supply Current vs Supply Voltage vs Temperature ..... 10

    16.2 RR121-1B13-311 & RR121-1B13-312 Average Supply Current vs Temperature vs Supply Voltage ..... 10

    16.3 RR121-1B13-311 & RR121-1B13-312 Sampling Frequency vs Supply Voltage vs Temperature ..... 10

    16.4 RR121-1B13-311 & RR121-1B13-312 B<sub>OPN</sub> (Blue) and B<sub>OPS</sub> (Red) vs Supply Voltage at +25°C ..... 11

    16.5 RR121-1B13-311 & RR121-1B13-312 B<sub>RPN</sub> (Blue) and B<sub>RPS</sub> (Red) vs Supply Voltage at +25°C ..... 11

    16.6 RR121-1B13-311 & RR121-1B13-312 B<sub>OPN</sub> (Blue) and B<sub>OPS</sub> (Red) vs Operating Temperature at V<sub>DD</sub>=3.0 V ..... 11

    16.7 RR121-1B13-311 & RR121-1B13-312 B<sub>RPN</sub> (Blue) and B<sub>RPS</sub> (Red) vs Operating Temperature at V<sub>DD</sub>=3.0 V ..... 11

    16.8 RR121-1A23-311 Average Supply Current vs Supply Voltage vs Temperature ..... 12

    16.9 RR121-1A23-311 Average Supply Current vs Temperature vs Supply Voltage ..... 12

    16.10 RR121-1A23-311 Sampling Frequency vs Supply Voltage vs Temperature ..... 12

    16.11 RR121-1A23-311 B<sub>OPN</sub> (Blue) and B<sub>OPS</sub> (Red) vs Supply Voltage at +25°C ..... 13

    16.12 RR121-1A23-311 B<sub>RPN</sub> (Blue) and B<sub>RPS</sub> (Red) vs Supply Voltage at +25°C ..... 13

    16.13 RR121-1A23-311 B<sub>OPN</sub> (Blue) and B<sub>OPS</sub> (Red) vs Operating Temperature at V<sub>DD</sub>=3.0 V ..... 13

    16.14 RR121-1A23-311 B<sub>RPN</sub> (Blue) and B<sub>RPS</sub> (Red) vs Operating Temperature at V<sub>DD</sub>=3.0 V ..... 13

    16.15 RR121-1B53-311 & RR121-1A53-311 Average Supply Current vs Supply Voltage vs Temperature ..... 14

    16.16 RR121-1B53-311 & RR121-1A53-311 Average Supply Current vs Temperature vs Supply Voltage ..... 14

    16.17 RR121-1B53-311 & RR121-1A53-311 Sampling Frequency vs Supply Voltage vs Temperature ..... 14

    16.18 RR121-1B53-311 B<sub>OPN</sub> (Blue) and B<sub>OPS</sub> (Red) vs Supply Voltage at +25°C ..... 15

    16.19 RR121-1B53-311 B<sub>RPN</sub> (Blue) and B<sub>RPS</sub> (Red) vs Supply Voltage at +25°C ..... 15

    16.20 RR121-1B53-311 B<sub>OPN</sub> (Blue) and B<sub>OPS</sub> (Red) vs Operating Temperature at V<sub>DD</sub>=3.0 V ..... 15

    16.21 RR121-1B53-311 B<sub>RPN</sub> (Blue) and B<sub>RPS</sub> (Red) vs Operating Temperature at V<sub>DD</sub>=3.0 V ..... 15

    16.22 RR121-3C63-311 Average Supply Current vs Supply Voltage vs Temperature ..... 16

    16.23 RR121-3C63-311 Average Supply Current vs Temperature vs Supply Voltage ..... 16

16.24	RR121-3C63-311 Sampling Frequency vs Supply Voltage vs Temperature .....	16
16.25	RR121-1E73-311 & RR121-3C73-311 Average Supply Current vs Supply Voltage vs Temperature .....	17
16.26	RR121-1E73-311 & RR121-3C73-311 Average Supply Current vs Temperature vs Supply Voltage .....	17
16.27	RR121-1E73-311 & RR121-3C73-311 Sampling Frequency vs Supply Voltage vs Temperature .....	17
16.28	RR121-1B93-312 & RR121-3C73-311 Sampling Frequency vs Supply Voltage vs Temperature .....	17
16.29	RR121-1B93-312 B <sub>OPN</sub> (Blue) and B <sub>OPS</sub> (Red) vs Supply Voltage at +25°C .....	18
16.30	RR121-1B93-312 B <sub>RPN</sub> (Blue) and B <sub>RPS</sub> (Red) vs Supply Voltage at +25°C .....	18
16.31	RR121-1B93-312 B <sub>OPN</sub> (Blue) and B <sub>OPS</sub> (Red) vs Operating Temperature at V <sub>DD</sub> =3.0 V .....	18
16.32	RR121-1B93-312 B <sub>RPN</sub> (Blue) and B <sub>RPS</sub> (Red) vs Operating Temperature at V <sub>DD</sub> =3.0 V .....	18
16.33	RR121-1B93-312 Average Supply Current vs Supply Voltage vs Temperature .....	19
16.34	RR121-1B93-312 Average Supply Current vs Temperature vs Supply Voltage .....	19
17.	Application Information .....	20
17.1	Application Circuit (SOT-23-3) .....	20
17.2	Application Circuit (LGA-4) .....	20
17.3	Application Circuit (Leaded LGA-4) .....	20
18.	Part Selection & Ordering Information .....	21
18.1	Part Selection Table .....	21
18.2	Device Nomenclature Ordering Information .....	21
19.	Axis of Sensitivity .....	21
20.	Dimensions .....	22
20.1	LGA-4 Package Dimensions .....	22
20.2	SOT-23-3 Package Dimensions .....	22
20.3	Leaded LGA-4 Package Dimensions .....	22
21.	TMR Sensor Location .....	23
21.1	LGA Package .....	23
21.2	SOT Package .....	23
21.3	Leaded LGA Package .....	23
21.4	SOT Package - Side View .....	23
21.5	LGA & Leaded LGA Package - Side View .....	23
22.	Magnetic Flux Response Diagrams .....	24
22.1	Omnipolar Magnetic Flux Response (Active Low Option) .....	24
22.2	Bipolar Magnetic Flux Response (Active Low Option) .....	24
22.3	Unipolar Magnetic Flux Response (Dual Active Low Option) .....	24
23.	Output Behavior vs. Magnetic Field Diagrams .....	25
23.1	Output Behavior vs. Magnetic Field - Omnipolar .....	25
23.2	Output Behavior vs. Magnetic Field - Bipolar .....	25
23.3	Output Behavior vs. Magnetic Field - Unipolar (Dual Output) .....	25
24.	TMR Sensor & Switch Packaging .....	26
24.1	SOT-23-3 Tape & Reel Packaging .....	26
24.2	LGA-4 & Leaded LGA-4 Tape & Reel Packaging .....	27
24.3	RedRock TMR Packaging .....	28
25.	Suggested Pb-Free Reflow Profile .....	28
26.	Suggested Solder Pad Layout .....	29
26.1	SOT-23-3 Solder Pad Layout .....	29
26.2	LGA-4 Solder Pad Layout .....	29
26.3	Leaded LGA-4 Solder Pad Layout .....	29

## 4 Specifications for all RR121 Series Sensors

### 4.1 Absolute Environmental Ratings for all RR121 Series Sensors<sup>1</sup>

Parameters	Units	Min	Typ	Max
Operating Temperature ( $T_{OP}$ )	°C	-40		+125
Storage Temperature ( $T_{STG}$ )	°C	-65		+150
Junction Temperature ( $T_J$ )	°C			+150
Soldering Temperature (3 cycles, 1 min.) ( $T_{SOL}$ )	°C			+260
ESD Level Human Body Model per JESD22-A114	V	±4000		
Magnetic Field Exposure	G			2000

### 4.2 Absolute Electrical Ratings for all RR121 Series Sensors<sup>1</sup>

Parameters	Units	Min	Typ	Max
Supply Voltage ( $V_{DD}$ )	V	-0.3		+4.0
Push-pull Output (Active Low)( $V_{OUT\_PP}$ )	V	-0.3		$V_{DD}$
Input and Output Current ( $I_{IN}/I_{OUT}$ )	mA	-10		+10

### 4.3 Operating Electrical Characteristics for all RR121 Series Sensors<sup>2</sup>

Parameters	Units	Min	Typ	Max
Supply Voltage ( $V_{DD}$ )	V	+2.7	+3.0	+3.6
Output Voltage (High) <sup>3</sup> ( $V_{OUTH}$ )	V	90% $V_{DD}$		
Output Voltage (Low) <sup>3</sup> ( $V_{OUTL}$ )	V			10% $V_{DD}$
Power-On Time ( $t_{ON}$ )( $V_{DD} > 2.7V$ )	μs		500	
Under-Voltage Lockout Threshold Rising $V_{DD}$ ( $V_{UVLO\_RISE}$ )	V		+2.20	+2.60
Under-Voltage Lockout Threshold Falling $V_{DD}$ ( $V_{UVLO\_FALL}$ )	V	+1.90	+2.15	
Under-Voltage Lockout Hysteresis ( $V_{UV\_HYST}$ )	mV		+50	

#### Notes:

- Exceeding Absolute Ratings may cause permanent damage to the device. Exposure at the maximum rated conditions for extended periods of time may also affect device reliability.
- Unless otherwise specified, all characteristics are measured at 25°C.
- See "Magnetic Field vs. Output Status" for more details.



ESD Note: This product uses semiconductors that can be damaged by electrostatic discharge (ESD). When handling, proper ESD precautions should be taken to avoid performance degradation or loss of functionality. Damage due to inappropriate handling is not covered under warranty.

## 5 Operating Characteristics for RR121-1B13-311 and RR121-1B13-312<sup>1</sup>

Parameters	Units	Min	Typ	Max
Average Supply Current ( $I_{DD(AVG)}$ ) <sup>2</sup>	nA		200	700
Switching Frequency ( $f_{SW}$ )	Hz	1	2	4
Active Mode Time ( $t_{ACT}$ )	μs		1.4	
Idle Mode Time ( $t_{IDLE}$ )	ms		500	
Operate Point ( $B_{OPN}$ )	G	27	30	38
Operate Point ( $B_{OPS}$ )	G	-38	-30	-27
Release Point ( $B_{RPN}$ )	G	18	20	27
Release Point ( $B_{RPS}$ )	G	-27	-20	-18
Hysteresis ( $B_{HYST}$ ) <sup>3</sup>	G	5	10	

**Notes:**

1. Unless otherwise specified,  $V_{DD} = 2.7\text{ V to }3.6\text{ V}$ ,  $T_A = -40^\circ\text{C to }+125^\circ\text{C}$ . Typical values are  $V_{DD} = 3.0\text{ V}$  and  $T_A = +25^\circ\text{C}$ .
2. Conditions:  $t = 10\text{ seconds}$
3. Conditions:  $B_{HYST} = |B_{OP} - B_{RP}|$

## 6 Operating Characteristics for RR121-1A23-311<sup>1</sup>

Parameters	Units	Min	Typ	Max
Average Supply Current ( $I_{DD(AVG)}$ ) <sup>2</sup>	nA		230	700
Switching Frequency ( $f_{SW}$ )	Hz	7	10	13
Active Mode Time ( $t_{ACT}$ )	μs		1.4	
Idle Mode Time ( $t_{IDLE}$ )	ms		100	
Operate Point ( $B_{OPN}$ )	G	8	9	12
Operate Point ( $B_{OPS}$ )	G	-12	-9	-8
Release Point ( $B_{RPN}$ )	G	3	5	7
Release Point ( $B_{RPS}$ )	G	-7	-5	-3
Hysteresis ( $B_{HYST}$ ) <sup>3</sup>	G	3	4	

**Notes:**

1. Unless otherwise specified,  $V_{DD} = 2.7\text{ V to }3.6\text{ V}$ ,  $T_A = -40^\circ\text{C to }+125^\circ\text{C}$ . Typical values are  $V_{DD} = 3.0\text{ V}$  and  $T_A = +25^\circ\text{C}$ .
2. Conditions:  $t = 10\text{ seconds}$
3. Conditions:  $B_{HYST} = |B_{OP} - B_{RP}|$

### 7 Operating Characteristics for RR121-1F23-311<sup>1</sup>

Parameters	Units	Min	Typ	Max
Average Supply Current ( $I_{DD(AVG)}$ ) <sup>2</sup>	nA		230	700
Switching Frequency ( $f_{SW}$ )	Hz	7	10	13
Active Mode Time ( $t_{ACT}$ )	$\mu$ s		1.1	
Idle Mode Time ( $t_{IDLE}$ )	ms	77		143
Operate Point ( $B_{OPN}$ )	G		70	
Operate Point ( $B_{OPS}$ )	G		-70	
Release Point ( $B_{RPN}$ )	G		50	
Release Point ( $B_{RPS}$ )	G		-50	
Hysteresis ( $B_{HYST}$ ) <sup>3</sup>	G		20	

OBSOLETE

**Notes:**

1. Unless otherwise specified,  $V_{DD} = 2.7\text{ V to }3.6\text{ V}$ ,  $T_A = -40^\circ\text{C to }+125^\circ\text{C}$ . Typical values are  $V_{DD} = 3.0\text{ V}$  and  $T_A = +25^\circ\text{C}$ .
2. Conditions:  $t = 10\text{ seconds}$
3. Conditions:  $B_{HYST} = |B_{OP} - B_{RP}|$

### 8 Operating Characteristics for RR121-1B53-311<sup>1</sup>

Parameters	Units	Min	Typ	Max
Average Supply Current ( $I_{DD(AVG)}$ ) <sup>2</sup>	$\mu$ A		1.4	2.5
Switching Frequency ( $f_{SW}$ )	Hz	165	250	300
Active Mode Time ( $t_{ACT}$ )	$\mu$ s		1.4	
Idle Mode Time ( $t_{IDLE}$ )	ms		4.0	
Operate Point ( $B_{OPN}$ )	G	27	30	38
Operate Point ( $B_{OPS}$ )	G	-38	-30	-27
Release Point ( $B_{RPN}$ )	G	18	20	27
Release Point ( $B_{RPS}$ )	G	-27	-20	-18
Hysteresis ( $B_{HYST}$ ) <sup>3</sup>	G	5	10	

**Notes:**

1. Unless otherwise specified,  $V_{DD} = 2.7\text{ V to }3.6\text{ V}$ ,  $T_A = -40^\circ\text{C to }+125^\circ\text{C}$ . Typical values are  $V_{DD} = 3.0\text{ V}$  and  $T_A = +25^\circ\text{C}$ .
2. Conditions:  $t = 10\text{ seconds}$
3. Conditions:  $B_{HYST} = |B_{OP} - B_{RP}|$

## 9 Operating Characteristics for RR121-1A53-311<sup>1</sup>

Parameters	Units	Min	Typ	Max
Average Supply Current ( $I_{DD(AVG)}$ ) <sup>2</sup>	μA		1.2	2.5
Switching Frequency ( $f_{SW}$ )	Hz	165	250	300
Active Mode Time ( $t_{ACT}$ )	μs		1.4	
Idle Mode Time ( $t_{IDLE}$ )	ms	3.3	4.0	6.0
Operate Point ( $B_{OPN}$ )	G	8	9	12
Operate Point ( $B_{OPS}$ )	G	-12	-9	-8
Release Point ( $B_{RPN}$ )	G	3	5	7
Release Point ( $B_{RPS}$ )	G	-7	-5	-3
Hysteresis ( $B_{HYST}$ ) <sup>3</sup>	G	3	4	

## 10 Operating Characteristics for RR121-1E73-311<sup>1</sup>

Parameters	Units	Min	Typ	Max
Average Supply Current ( $I_{DD(AVG)}$ ) <sup>2</sup>	μA		8	13
Switching Frequency ( $f_{SW}$ )	kHz	1.63	2.50	3.25
Active Mode Time ( $t_{ACT}$ )	μs		1.4	
Idle Mode Time ( $t_{IDLE}$ )	μs	308	400	614
Operate Point ( $B_{OPN}$ )	G	13	15	18
Operate Point ( $B_{OPS}$ )	G	-18	-15	-13
Release Point ( $B_{RPN}$ )	G	8	10	13
Release Point ( $B_{RPS}$ )	G	-13	-10	-8
Hysteresis ( $B_{HYST}$ ) <sup>3</sup>	G	3	5	

## 11 Operating Characteristics for RR121-1B93-312<sup>1</sup>

Parameters	Units	Min	Typ	Max
Average Supply Current ( $I_{DD(AVG)}$ ) <sup>2</sup>	μA		36	
Switching Frequency ( $f_{SW}$ )	kHz	7	10	13
Active Mode Time ( $t_{ACT}$ )	μs		1.4	
Idle Mode Time ( $t_{IDLE}$ )	μs	77	100	143
Operate Point ( $B_{OPN}$ )	G	27	30	38
Operate Point ( $B_{OPS}$ )	G	-38	-30	-27
Release Point ( $B_{RPN}$ )	G	18	20	27
Release Point ( $B_{RPS}$ )	G	-27	-20	-18
Hysteresis ( $B_{HYST}$ ) <sup>3</sup>	G	5	10	

### Notes:

1. Unless otherwise specified,  $V_{DD} = 2.7\text{ V to }3.6\text{ V}$ ,  $T_A = -40^\circ\text{C to }+125^\circ\text{C}$ . Typical values are  $V_{DD} = 3.0\text{ V}$  and  $T_A = +25^\circ\text{C}$ .

2. Conditions:  $t = 10\text{ seconds}$

3. Conditions:  $B_{HYST} = |B_{OP} - B_{RP}|$

## 12 Operating Characteristics for RR121-2A32-364<sup>1</sup>

Parameters	Units	Min	Typ	Max
Average Supply Current ( $I_{DD(AVG)}$ ) <sup>2</sup>	nA		280	700
Switching Frequency ( $f_{SW}$ )	Hz	12	20	28
Active Mode Time ( $t_{ACT}$ )	$\mu$ s		1.4	
Idle Mode Time ( $t_{IDLE}$ )	ms	36	50	83
Operate Point ( $B_{OPN}$ )	G	8	9	12
Operate Point ( $B_{OPS}$ )	G	-12	-9	-8
Release Point ( $B_{RPN}$ )	G	3	5	7
Release Point ( $B_{RPS}$ )	G	-7	-5	-3
Hysteresis ( $B_{HYST}$ ) <sup>3</sup>	G	3	4	

## 13 Operating Characteristics for RR121-3C63-311<sup>1</sup>

Parameters	Units	Min	Typ	Max
Average Supply Current ( $I_{DD(AVG)}$ ) <sup>2</sup>	$\mu$ A		1.7	3.3
Switching Frequency ( $f_{SW}$ )	Hz	325	500	600
Active Mode Time ( $t_{ACT}$ )	$\mu$ s		1.4	
Idle Mode Time ( $t_{IDLE}$ )	ms		2.0	
Operate Point ( $B_{OPS}$ )	G	-14	-10	-8
Release Point ( $B_{RPN}$ )	G	8	10	14

## 14 Operating Characteristics for RR121-3C73-311<sup>1</sup>

Parameters	Units	Min	Typ	Max
Average Supply Current ( $I_{DD(AVG)}$ ) <sup>2</sup>	$\mu$ A		8	13
Switching Frequency ( $f_{SW}$ )	kHz	1.63	2.50	3.25
Active Mode Time ( $t_{ACT}$ )	$\mu$ s		1.4	
Idle Mode Time ( $t_{IDLE}$ )	$\mu$ s	308	400	614
Operate Point ( $B_{OPS}$ )	G	-14	-10	-8
Release Point ( $B_{RPN}$ )	G	8	10	14

### Notes:

1. Unless otherwise specified,  $V_{DD} = 2.7$  V to 3.6 V,  $T_A = -40^\circ\text{C}$  to  $+125^\circ\text{C}$ . Typical values are  $V_{DD} = 3.0$  V and  $T_A = +25^\circ\text{C}$ .
2. Conditions:  $t = 10$  seconds
3. Conditions:  $B_{HYST} = |B_{OP} - B_{RP}|$

### 15 Operate & Release Lobe Plots

Operate and release distances show are relative. The actual operate and release distances will depend on the type of magnet that is used.

15.1 RR121-1B13-311

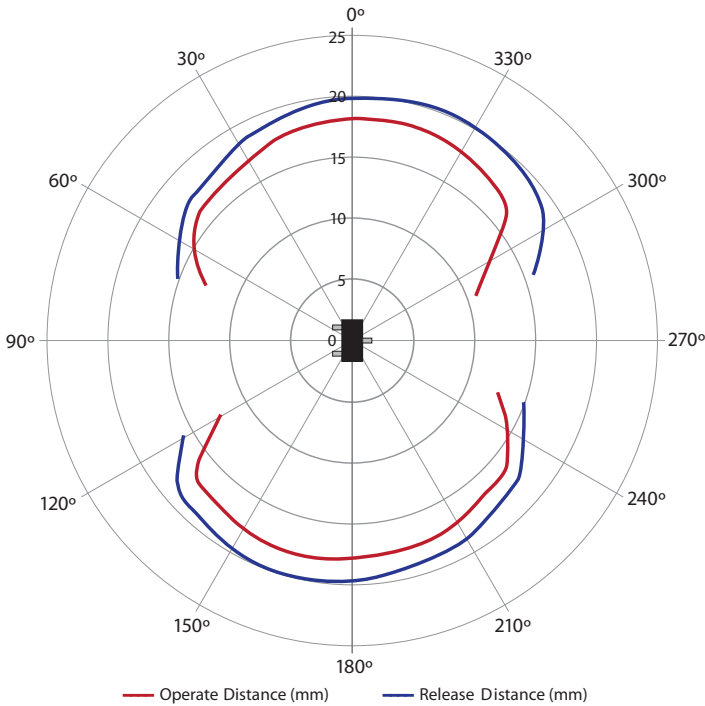

15.2 RR121-1B13-312

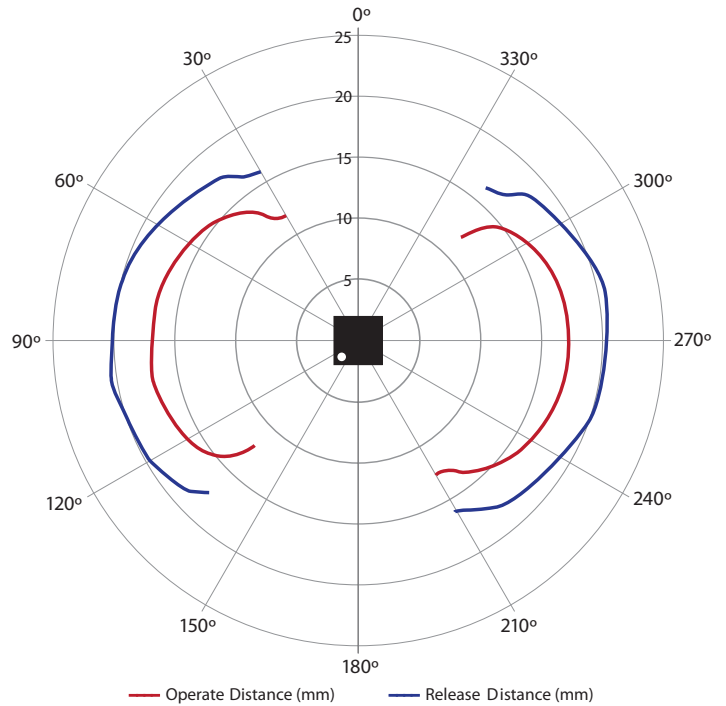

15.3 RR121-1A23-311

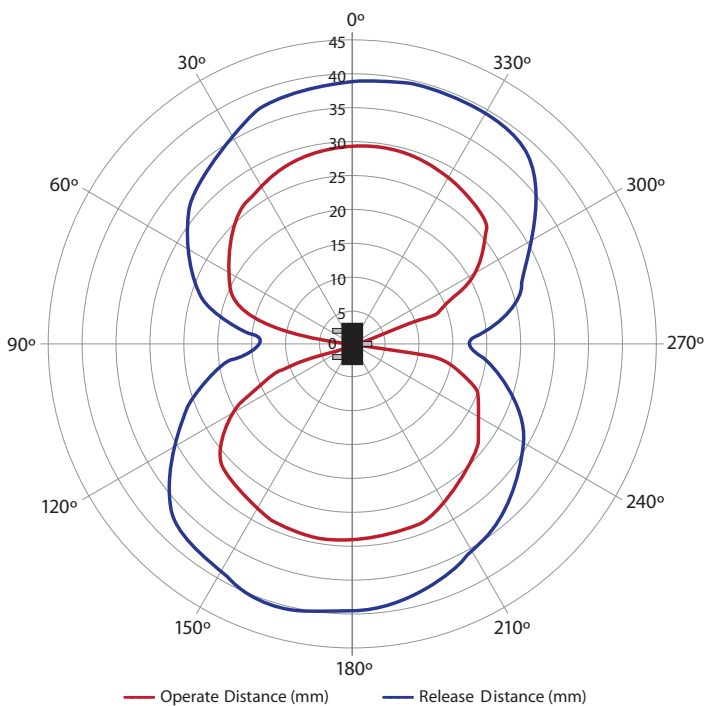

15.4 RR121-1B53-311

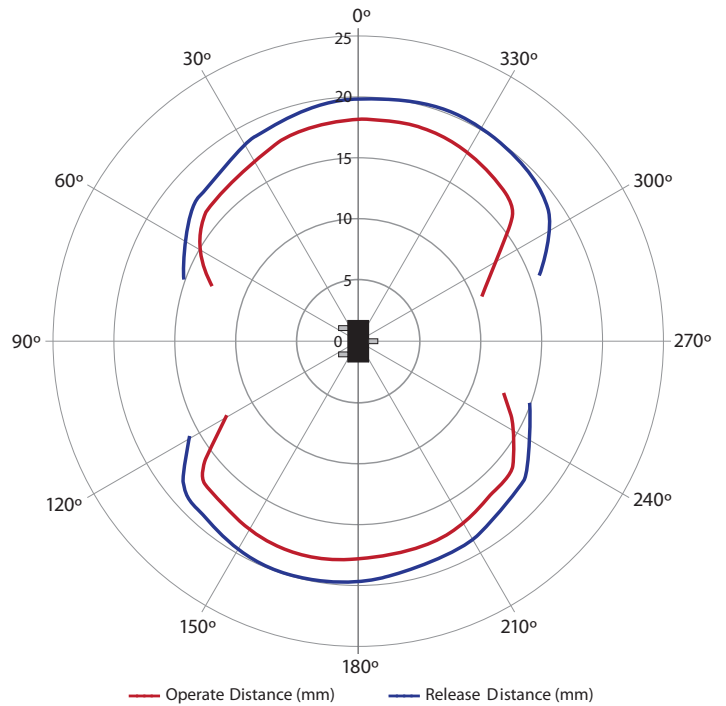

## 16 Graphs - Typical Electrical Characteristics

$V_{DD} = 3.0\text{ V}$  and  $T_A = +25\text{ }^\circ\text{C}$ ,  $C_{DD} = 1.0\text{ }\mu\text{F}$  (unless otherwise specified)

**16.1 RR121-1B13-311 and RR121-1B13-312  
Average Supply Current vs.  
Supply Voltage vs. Temperature**

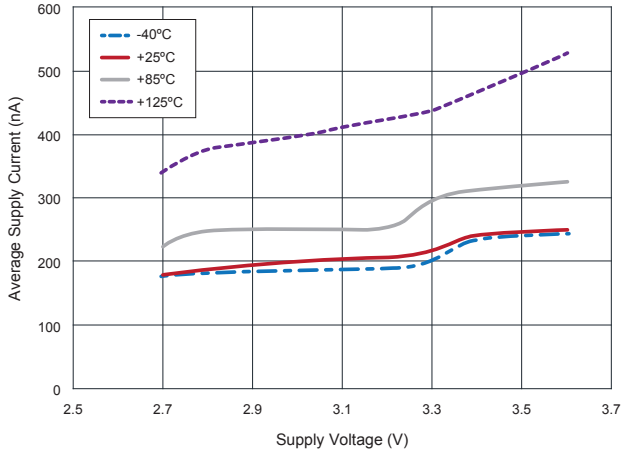

**16.2 RR121-1B13-311 and RR121-1B13-312  
Average Supply Current vs.  
Temperature vs. Supply Voltage**

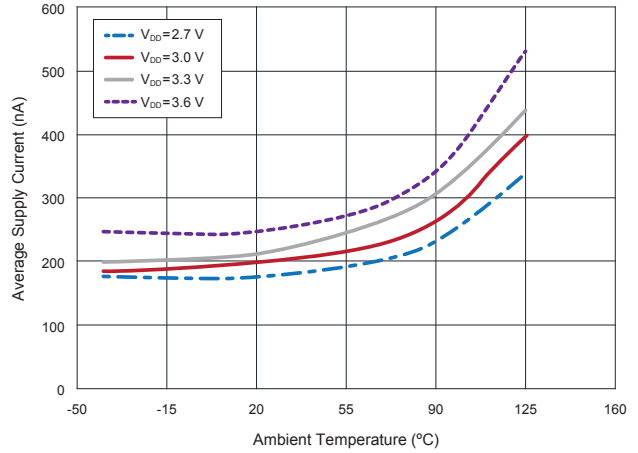

**16.3 RR121-1B13-311 and RR121-1B13-312  
Sampling Frequency vs.  
Supply Voltage vs. Temperature**

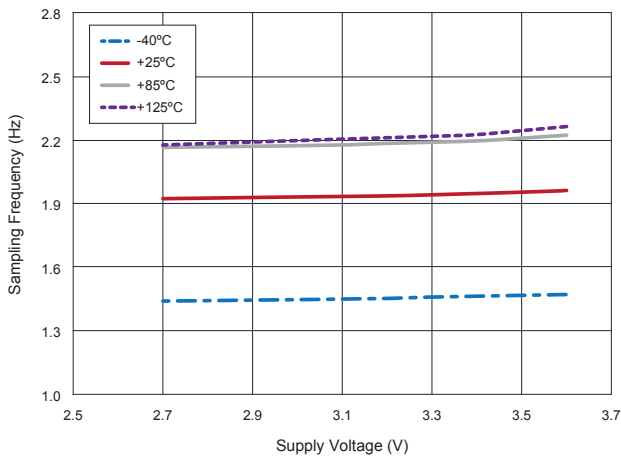

### 16 Graphs - Typical Magnetic Characteristics

$V_{DD} = 3.0\text{ V}$  and  $T_A = +25\text{ }^\circ\text{C}$ ,  $C_{DD} = 1.0\text{ }\mu\text{F}$  (unless otherwise specified)

**16.4 RR121-1B13-311 and RR121-1B13-312**  
 $B_{OPN}$  (Blue) and  $B_{OPS}$  (Red) vs.  
 Supply Voltage at  $+25^\circ\text{C}$

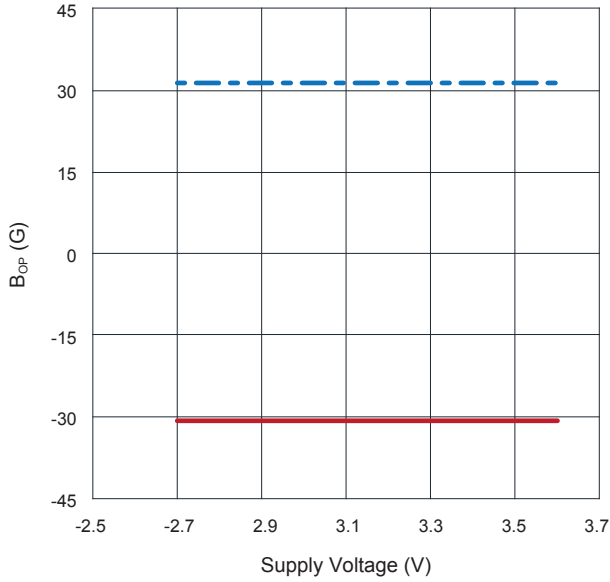

**16.5 RR121-1B13-311 and RR121-1B13-312**  
 $B_{RPN}$  (Blue) and  $B_{RPS}$  (Red) vs.  
 Supply Voltage at  $+25^\circ\text{C}$

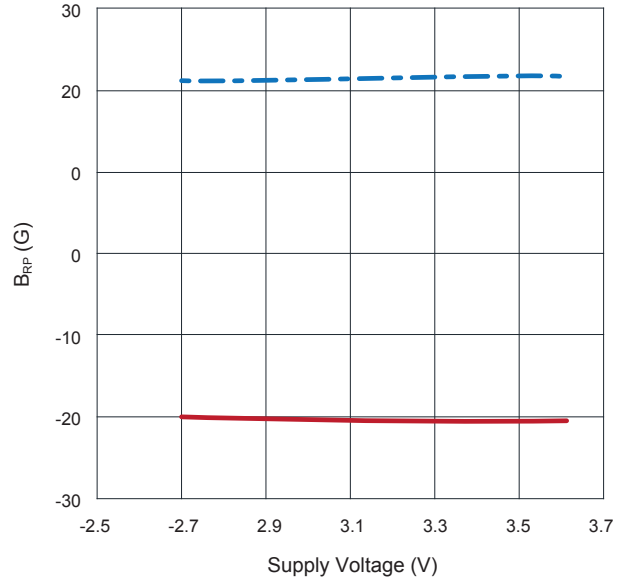

**16.6 RR121-1B13-311 and RR121-1B13-312**  
 $B_{OPN}$  (Blue) and  $B_{OPS}$  (Red) vs.  
 Operating Temperature at  $V_{DD}=3.0\text{ V}$

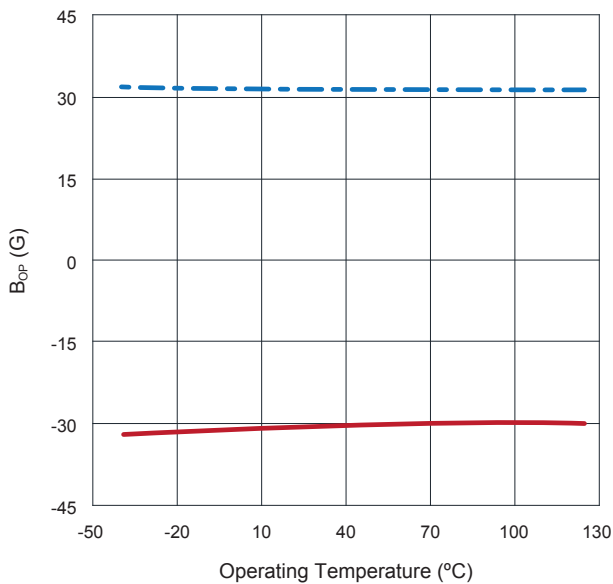

**16.7 RR121-1B13-311 and RR121-1B13-312**  
 $B_{RPN}$  (Blue) and  $B_{RPS}$  (Red) vs.  
 Operating Temperature at  $V_{DD}=3.0\text{ V}$

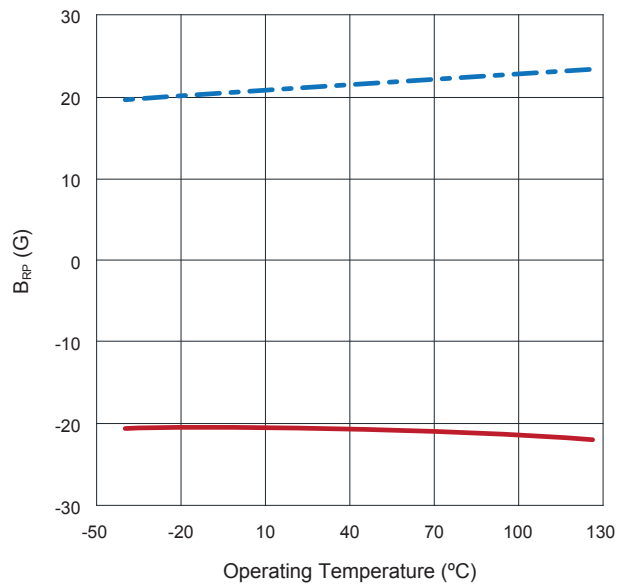

### 16 Graphs - Typical Characteristics

$V_{DD} = 3.0\text{ V}$  and  $T_A = +25\text{ }^\circ\text{C}$ ,  $C_{DD} = 1.0\text{ }\mu\text{F}$  (unless otherwise specified)

**16.8 RR121-1A23-311**  
Average Supply Current vs. Supply Voltage vs. Temperature

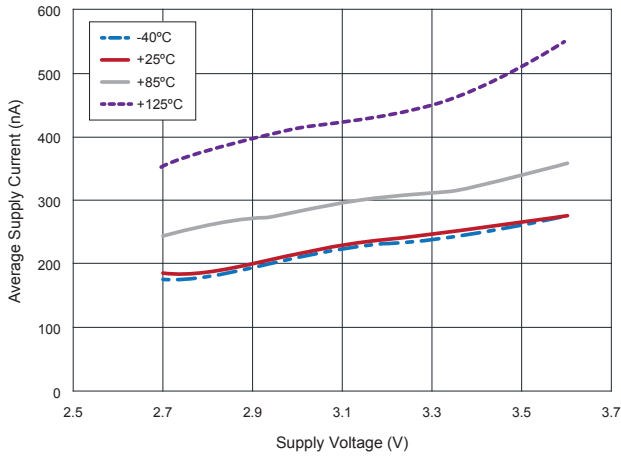

**16.9 RR121-1A23-311**  
Average Supply Current vs. Temperature vs. Supply Voltage

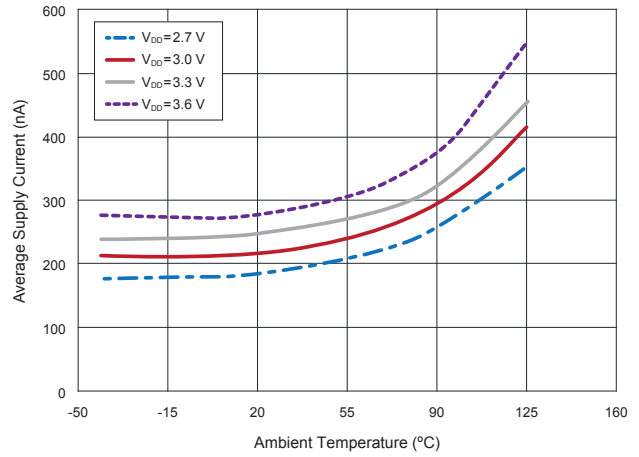

**16.10 RR121-1A23-311**  
Sampling Frequency vs. Supply Voltage vs. Temperature

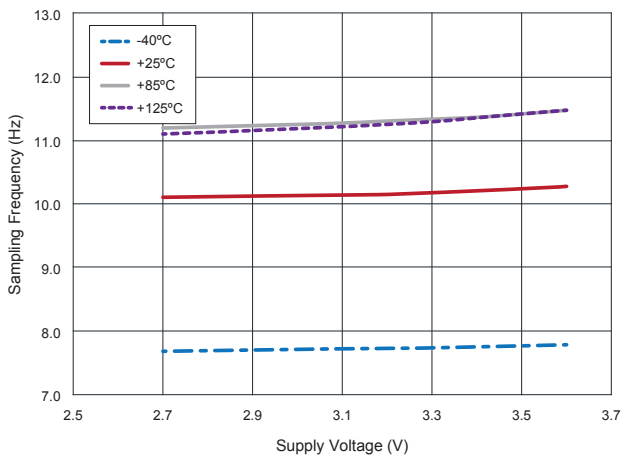

16 Graphs - Typical Magnetic Characteristics

$V_{DD} = 3.0\text{ V}$  and  $T_A = +25\text{ }^\circ\text{C}$ ,  $C_{DD} = 1.0\text{ }\mu\text{F}$  (unless otherwise specified)

**16.11 RR121-1A23-311**  
 $B_{OPN}$  (Blue) and  $B_{OPS}$  (Red) vs.  
 Supply Voltage at  $+25^\circ\text{C}$

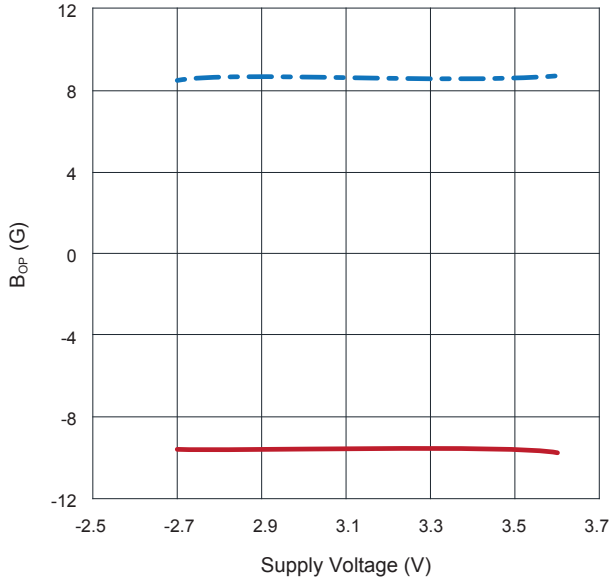

**16.12 RR121-1A23-311**  
 $B_{RPN}$  (Blue) and  $B_{RPS}$  (Red) vs.  
 Supply Voltage at  $+25^\circ\text{C}$

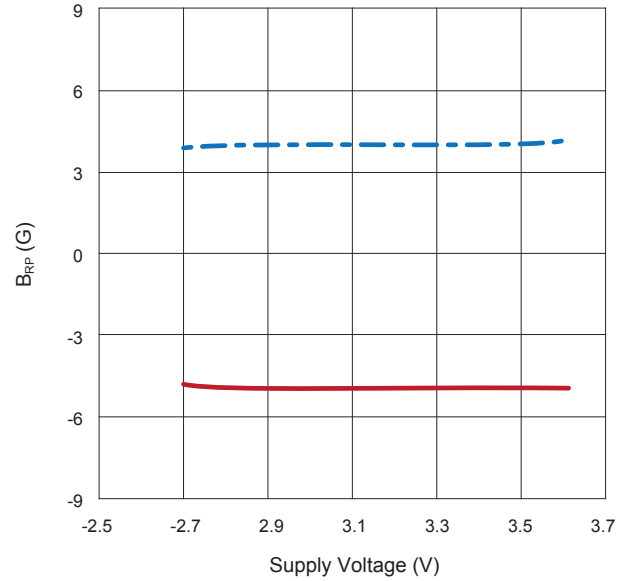

**16.13 RR121-1A23-311**  
 $B_{OPN}$  (Blue) and  $B_{OPS}$  (Red) vs.  
 Operating Temperature at  $V_{DD}=3.0\text{ V}$

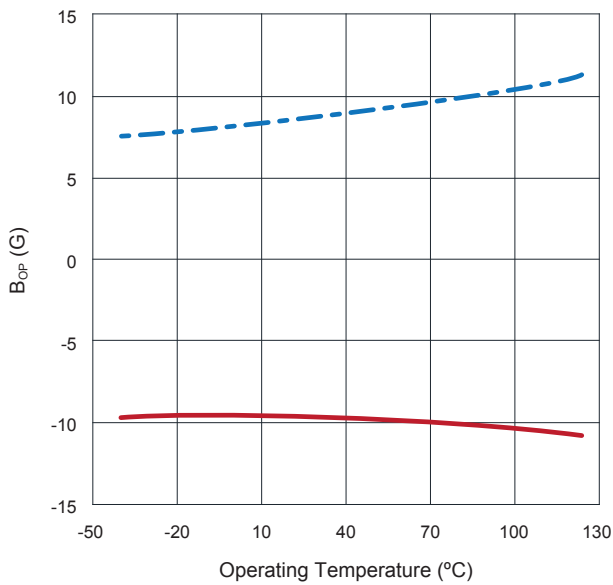

**16.14 RR121-1A23-311**  
 $B_{RPN}$  (Blue) and  $B_{RPS}$  (Red) vs.  
 Operating Temperature at  $V_{DD}=3.0\text{ V}$

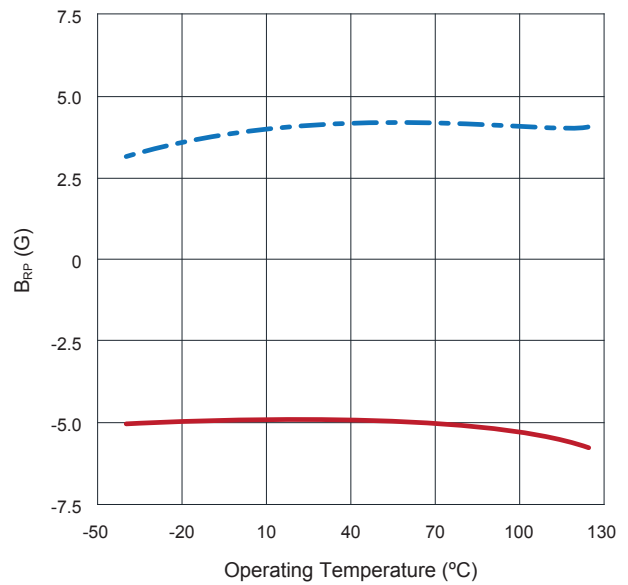

### 16 Graphs - Typical Characteristics

$V_{DD} = 3.0\text{ V}$  and  $T_A = +25\text{ }^\circ\text{C}$ ,  $C_{DD} = 1.0\text{ }\mu\text{F}$  (unless otherwise specified)

**16.15 RR121-1B53-311 and RR121-1A53-311  
Average Supply Current vs.  
Supply Voltage vs. Temperature**

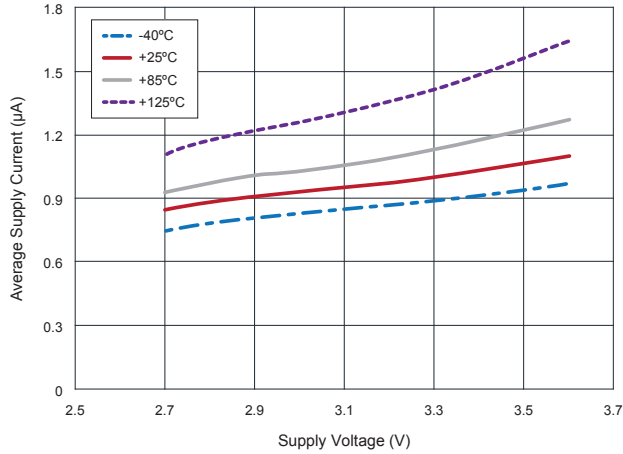

**16.16 RR121-1B53-311 and RR121-1A53-311  
Average Supply Current vs.  
Temperature vs. Supply Voltage**

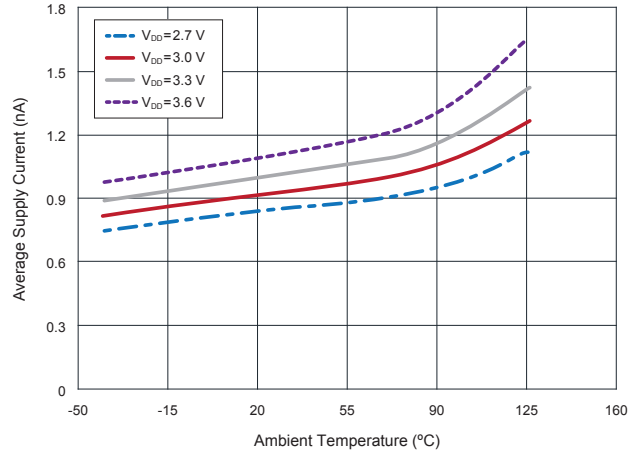

**16.17 RR121-1B53-311 and RR121-1A53-311  
Sampling Frequency vs.  
Supply Voltage vs. Temperature**

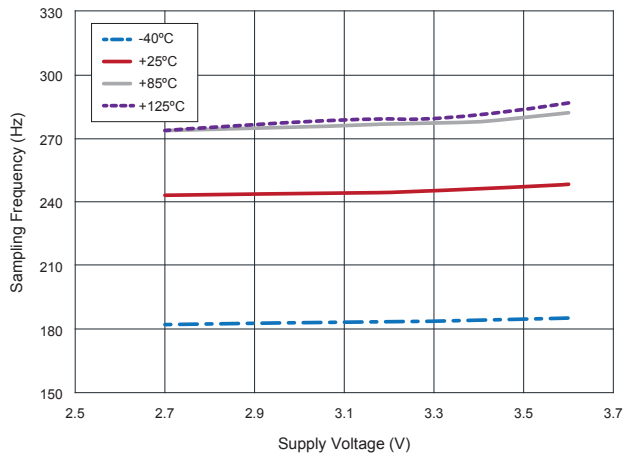

16 Graphs - Typical Magnetic Characteristics

$V_{DD} = 3.0\text{ V}$  and  $T_A = +25\text{ }^\circ\text{C}$ ,  $C_{DD} = 1.0\text{ }\mu\text{F}$  (unless otherwise specified)

**16.18 RR121-1B53-311**  
 **$B_{OPN}$  (Blue) and  $B_{OPS}$  (Red) vs.**  
**Supply Voltage at  $+25^\circ\text{C}$**

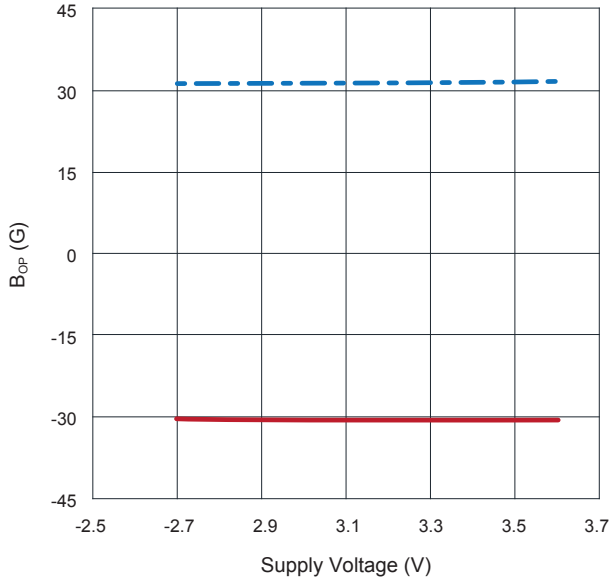

**16.19 RR121-1B53-311**  
 **$B_{RPN}$  (Blue) and  $B_{RPS}$  (Red) vs.**  
**Supply Voltage at  $+25^\circ\text{C}$**

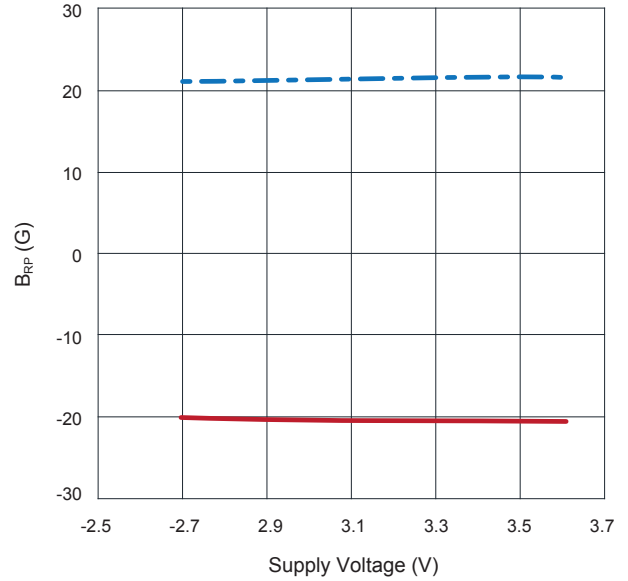

**16.20 RR121-1B53-311**  
 **$B_{OPN}$  (Blue) and  $B_{OPS}$  (Red) vs.**  
**Operating Temperature at  $V_{DD}=3.0\text{ V}$**

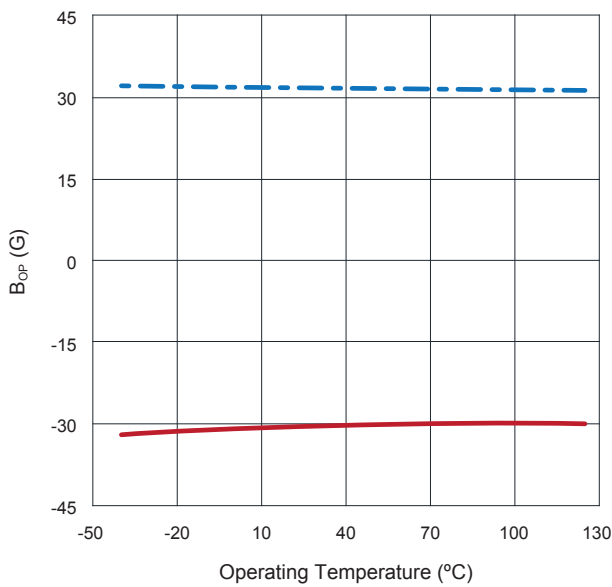

**16.21 RR121-1B53-311**  
 **$B_{RPN}$  (Blue) and  $B_{RPS}$  (Red) vs.**  
**Operating Temperature at  $V_{DD}=3.0\text{ V}$**

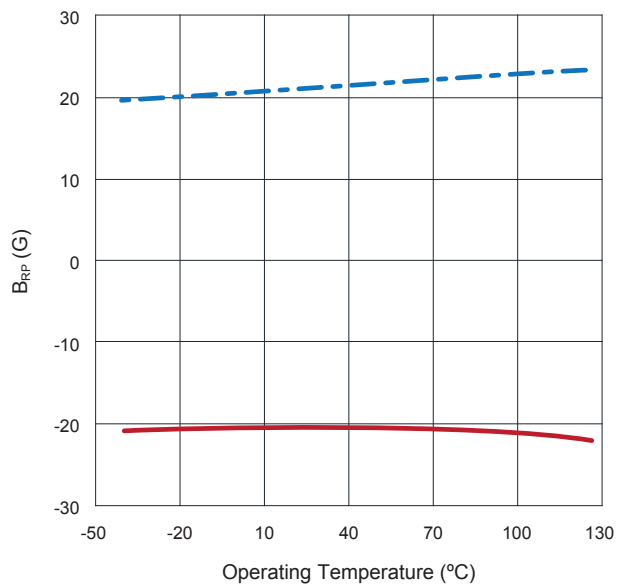

## 16 Graphs - Typical Characteristics

$V_{DD} = 3.0\text{ V}$  and  $T_A = +25\text{ }^\circ\text{C}$ ,  $C_{DD} = 1.0\text{ }\mu\text{F}$  (unless otherwise specified)

**16.22 RR121-3C63-311**  
**Average Supply Current vs.**  
**Supply Voltage vs. Temperature**

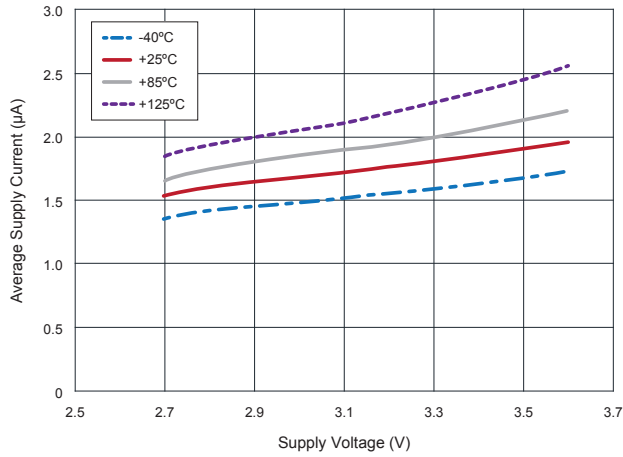

**16.23 RR121-3C63-311**  
**Average Supply Current vs.**  
**Temperature vs. Supply Voltage**

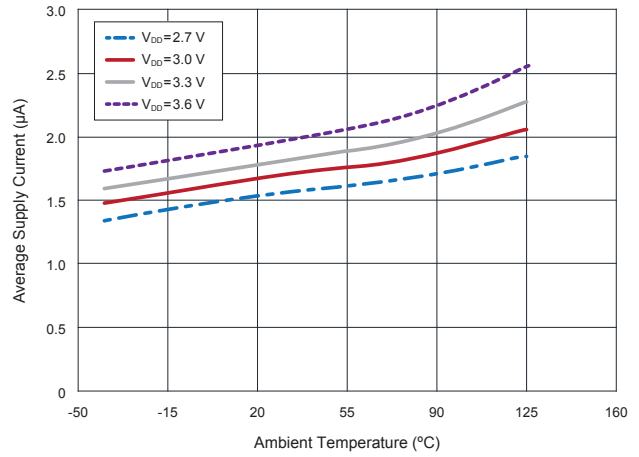

**16.24 RR121-3C63-311**  
**Sampling Frequency vs.**  
**Supply Voltage vs. Temperature**

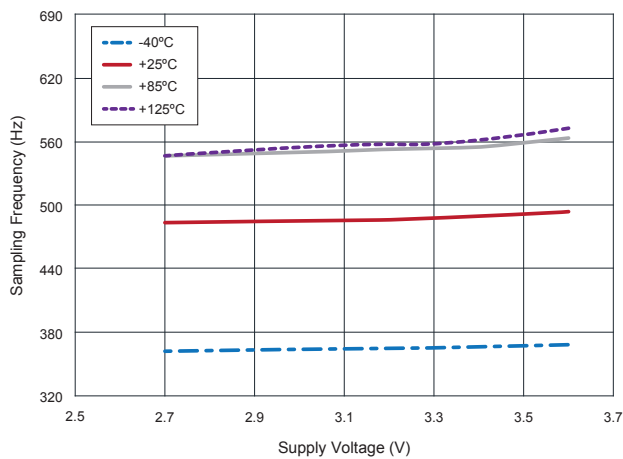

## 16 Graphs - Typical Characteristics

$V_{DD} = 3.0\text{ V}$  and  $T_A = +25\text{ }^\circ\text{C}$ ,  $C_{DD} = 1.0\text{ }\mu\text{F}$  (unless otherwise specified)

**16.25 RR121-1E73-311 and RR121-3C73-311**  
Average Supply Current vs. Supply Voltage vs. Temperature

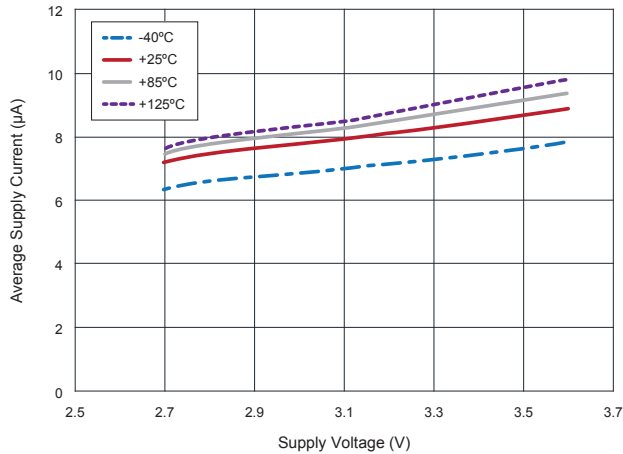

**16.26 RR121-1E73-311 and RR121-3C73-311**  
Average Supply Current vs. Temperature vs. Supply Voltage

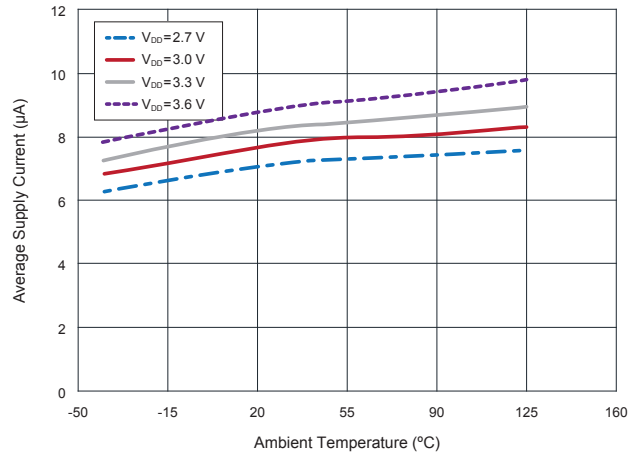

**16.27 RR121-1E73-311 and RR121-3C73-311**  
Sampling Frequency vs. Supply Voltage vs. Temperature

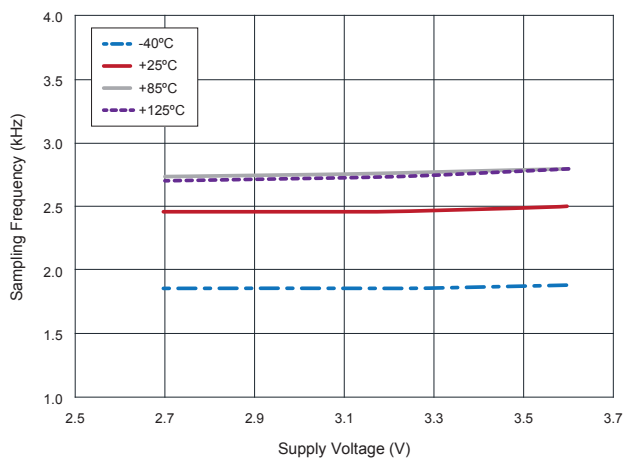

**16.28 RR121-1B93-312**  
Sampling Frequency vs. Supply Voltage vs. Temperature

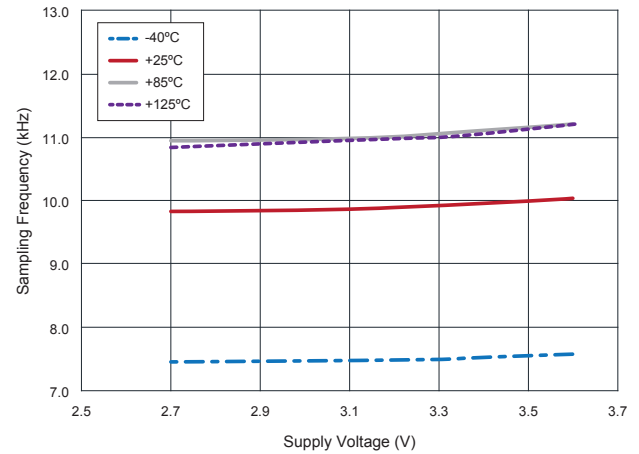

### 16 Graphs - Typical Magnetic Characteristics

$V_{DD} = 3.0\text{ V}$  and  $T_A = +25\text{ }^\circ\text{C}$ ,  $C_{DD} = 1.0\text{ }\mu\text{F}$  (unless otherwise specified)

**16.29 RR121-1B93-312**  
 **$B_{OPN}$  (Blue) and  $B_{OPS}$  (Red) vs.**  
**Supply Voltage at  $+25^\circ\text{C}$**

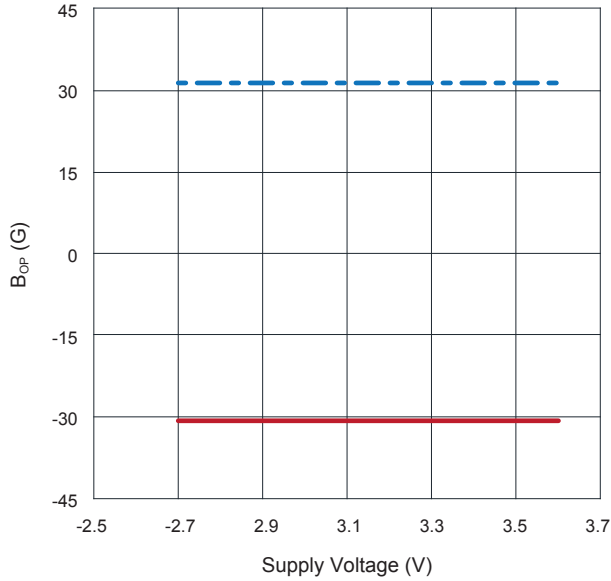

**16.30 RR121-1B93-312**  
 **$B_{RPN}$  (Blue) and  $B_{RPS}$  (Red) vs.**  
**Supply Voltage at  $+25^\circ\text{C}$**

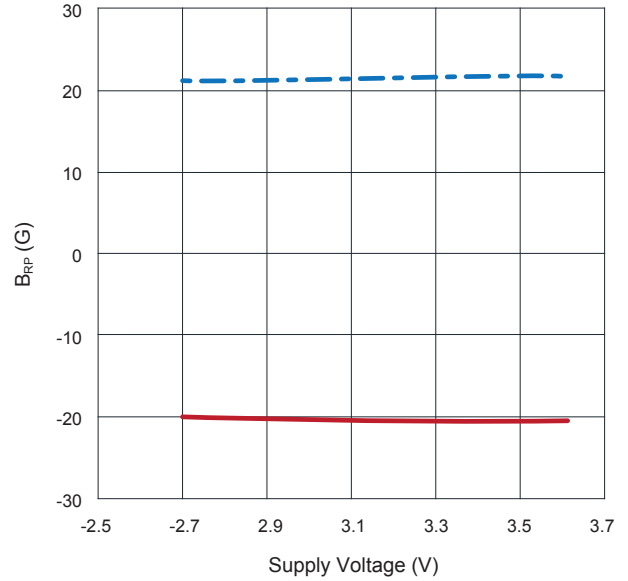

**16.31 RR121-1B93-312**  
 **$B_{OPN}$  (Blue) and  $B_{OPS}$  (Red) vs.**  
**Operating Temperature at  $V_{DD}=3.0\text{ V}$**

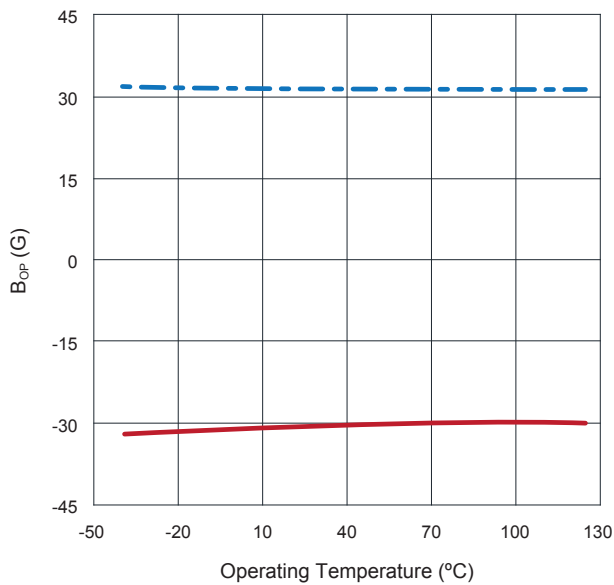

**16.32 RR121-1B93-312**  
 **$B_{RPN}$  (Blue) and  $B_{RPS}$  (Red) vs.**  
**Operating Temperature at  $V_{DD}=3.0\text{ V}$**

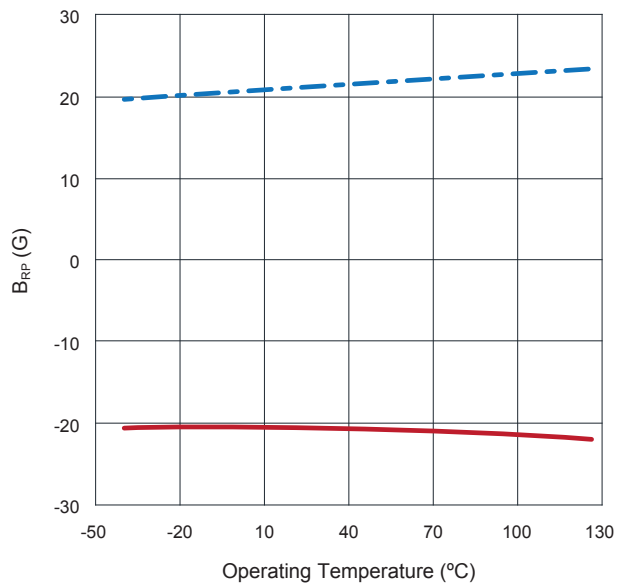

## 16 Graphs - Typical Electrical Characteristics

$V_{DD} = 3.0\text{ V}$  and  $T_A = +25\text{ }^\circ\text{C}$ ,  $C_{DD} = 1.0\text{ }\mu\text{F}$  (unless otherwise specified)

**16.33 RR121-1B93-312**  
**Average Supply Current vs.**  
**Supply Voltage vs. Temperature**

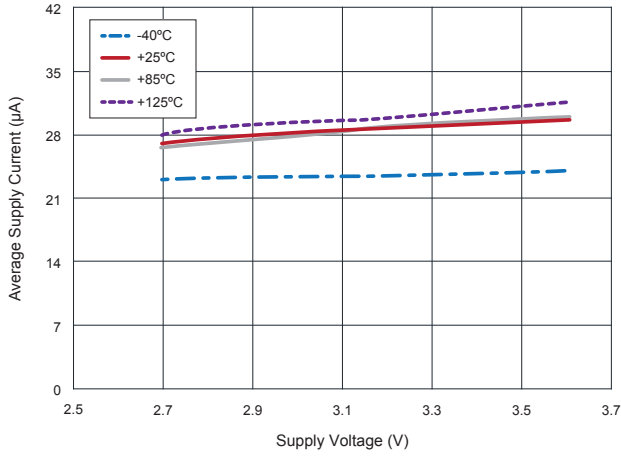

**16.34 RR121-1B93-312**  
**Average Supply Current vs.**  
**Temperature vs. Supply Voltage**

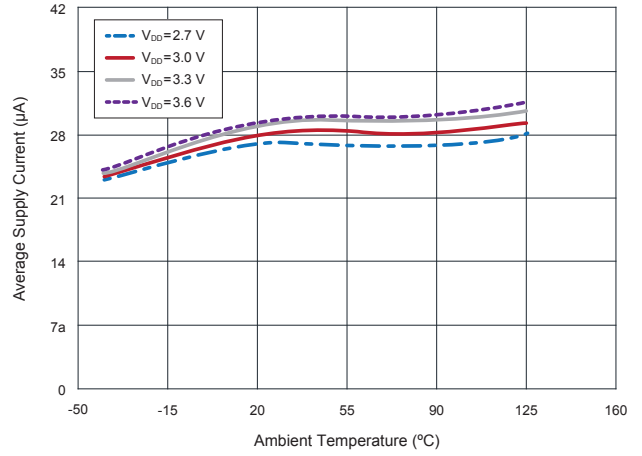

## 17 Application Information

**17.1 Application Circuit  
(SOT-23-3)**

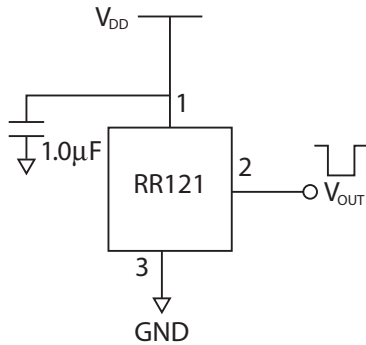

**17.2 Application Circuit  
(LGA-4)**

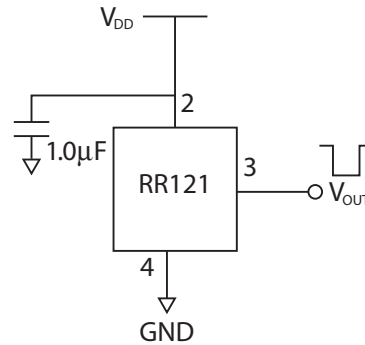

**17.3 Application Circuit  
(Leaded LGA-4)**

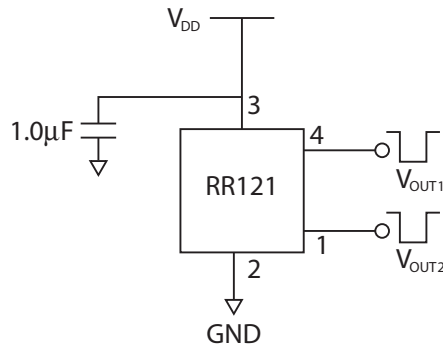

**RR121 Push-Pull Output Application Circuit**

The output voltage on the RR121 is active low, meaning that while a sufficiently strong magnetic field is present, the output voltage is low. The output voltage can be connected to a digital I/O pin on a microcontroller. A decoupling capacitor between the supply voltage and ground is required with placement close to the magnetic sensor. A typical capacitor value of 1.0 µF will suffice.

## 18 Part Selection and Ordering Information

### 18.1 Part Selection Table

Part Number	Magnetic Polarity Response	Operate Sensitivity (G)	Release Sensitivity (G)	Frequency (Hz)	I <sub>avg</sub> (μA)	Temp. Rating (°C)	Supply Voltage (V <sub>dd</sub> )	Output Response	Package
RR121-1B13-312	Omnipolar	30	20	2	0.20	-40 - +125	2.7 - 3.6	Active Low	LGA-4
RR121-1B13-311	Omnipolar	30	20	2	0.20	-40 - +125	2.7 - 3.6	Active Low	SOT-23-3
RR121-1B53-311	Omnipolar	30	20	250	1.44	-40 - +125	2.7 - 3.6	Active Low	SOT-23-3
RR121-1A23-311	Omnipolar	9	5	10	0.24	-40 - +125	2.7 - 3.6	Active Low	SOT-23-3
RR121-1A53-311	Omnipolar	9	5	250	1.44	-40 - +125	2.7 - 3.6	Active Low	SOT-23-3
RR121-1E73-311	Omnipolar	15	10	2500	8	-40 - +125	2.7 - 3.6	Active Low	SOT-23-3
RR121-1B93-312	Omnipolar	30	20	10000	36	-40 - +125	2.7 - 3.6	Active Low	LGA-4
RR121-2A32-364	Unipolar	9	5	20	0.28	-40 - +85	2.7 - 3.6	Dual Active Low	Leaded LGA-4
RR121-3C63-311	Bipolar	-10	10	500	1.70	-40 - +125	2.7 - 3.6	Active Low	SOT-23-3
RR121-3C73-311	Bipolar	-10	10	2500	8	-40 - +125	2.7 - 3.6	Active Low	SOT-23-3

**Note:**

1. Custom options available for Sensitivity, Frequency, Temperature Rating, Supply Voltage, Output Response & more. Please contact [redrock@cotorelay.com](mailto:redrock@cotorelay.com) for more details.

### 18.2 Device Nomenclature

#### Ordering Information

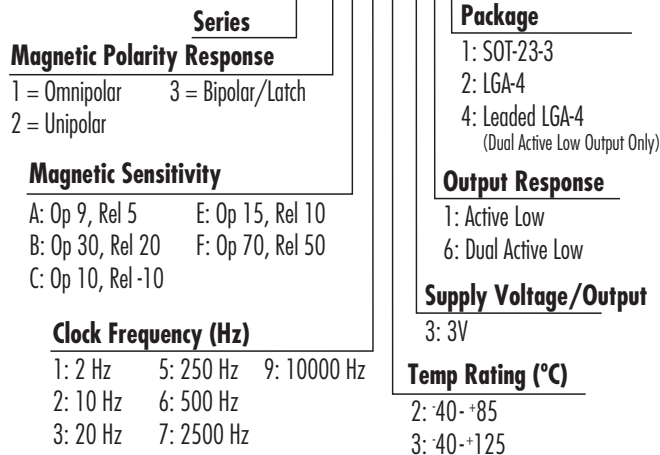
**RR121-X X X X-YY Y**

## 19 Axis of Sensitivity

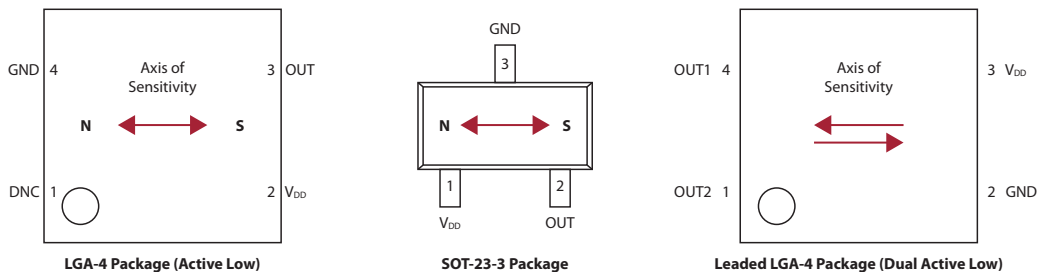

20 Dimensions *Millimeters (Inches)*

20.1 LGA-4 Package

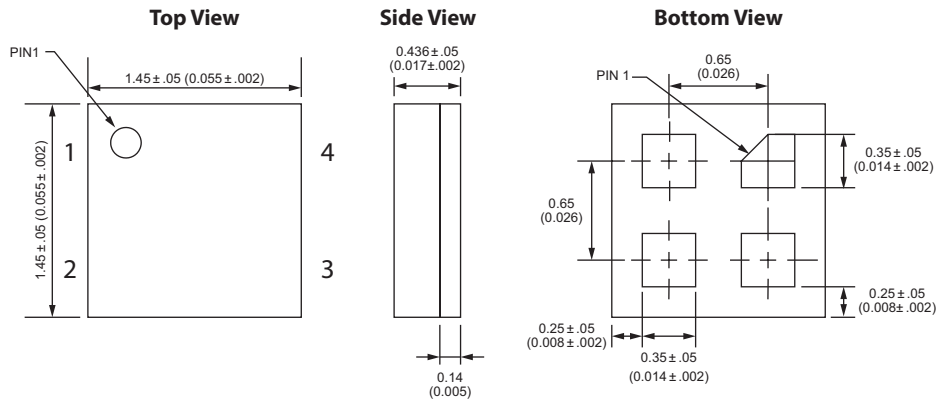

20.2 SOT-23-3 Package

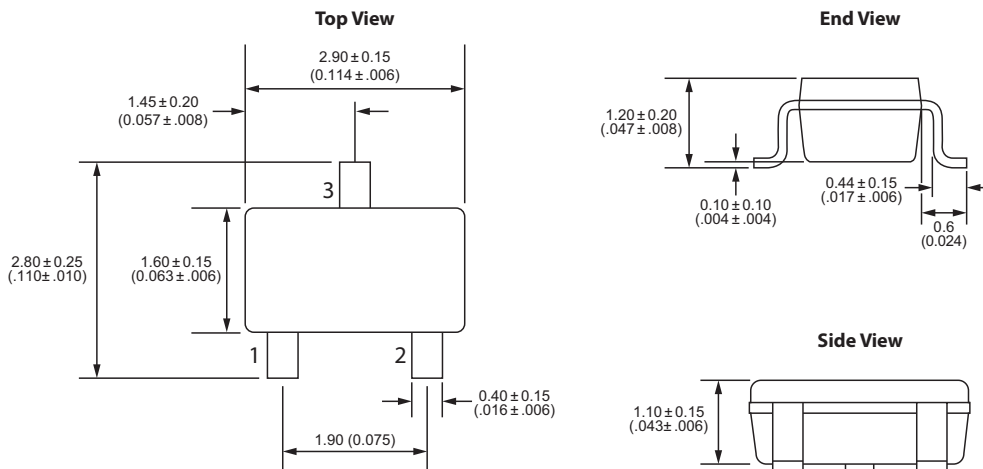

20.3 Leaded LGA-4 Package

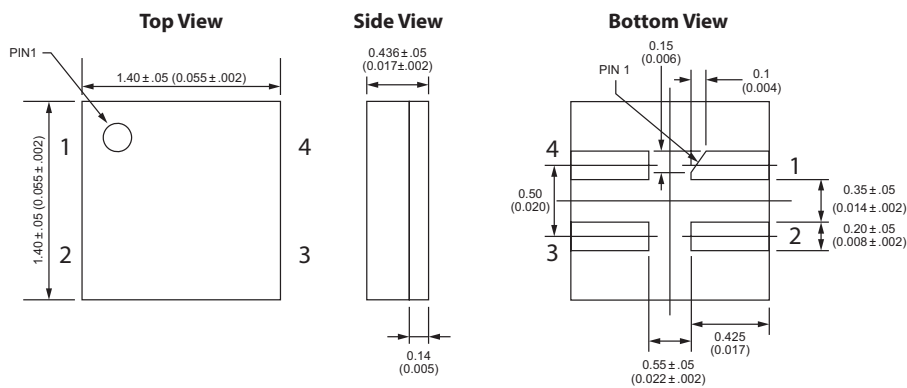

21 TMR Sensor Location

21.1 LGA Package

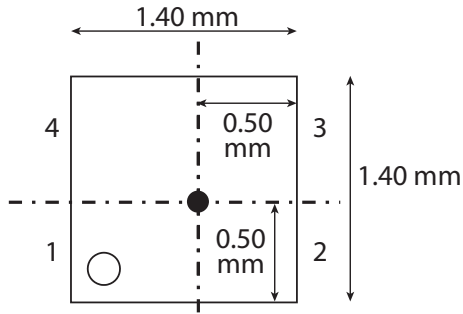

21.2 SOT Package

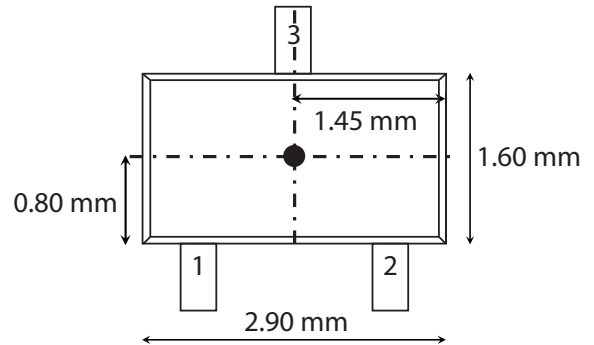

21.3 Leaded LGA Package

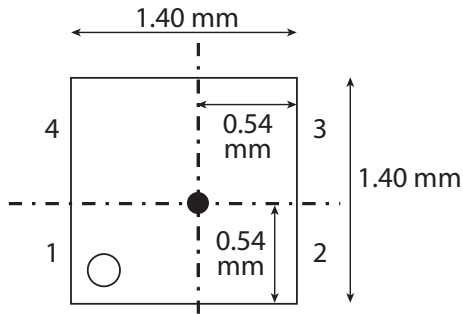

21.4 SOT Package - Side View

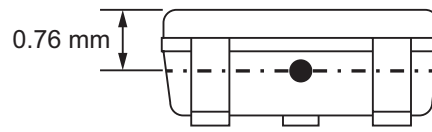

21.5 LGA & Leaded LGA Package - Side View

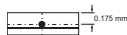

## 22 Magnetic Flux Response Diagrams

**22.1 Omnipolar Magnetic Flux Response (Active Low Option)**

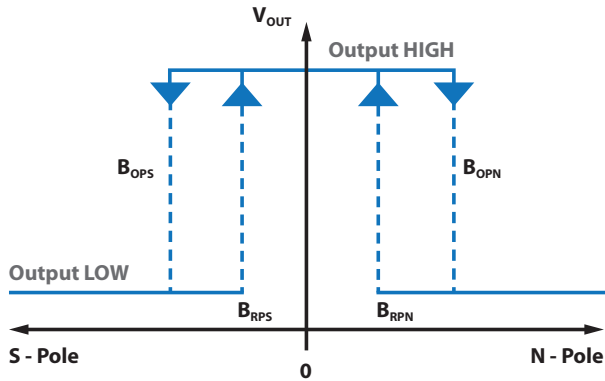

**22.2 Bipolar Magnetic Flux Response (Active Low Option)**

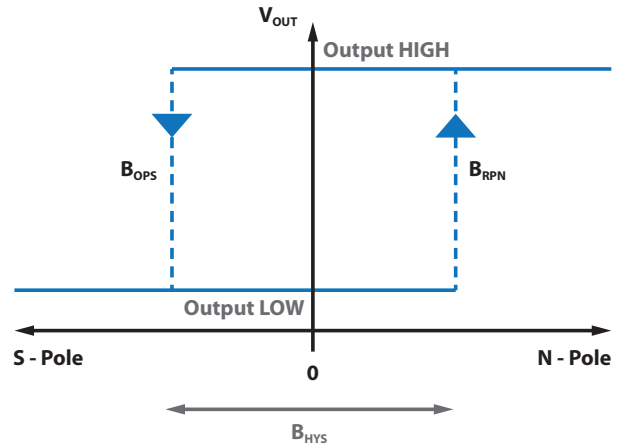

**22.3 Unipolar Magnetic Flux Response (Dual Active Low Option)**

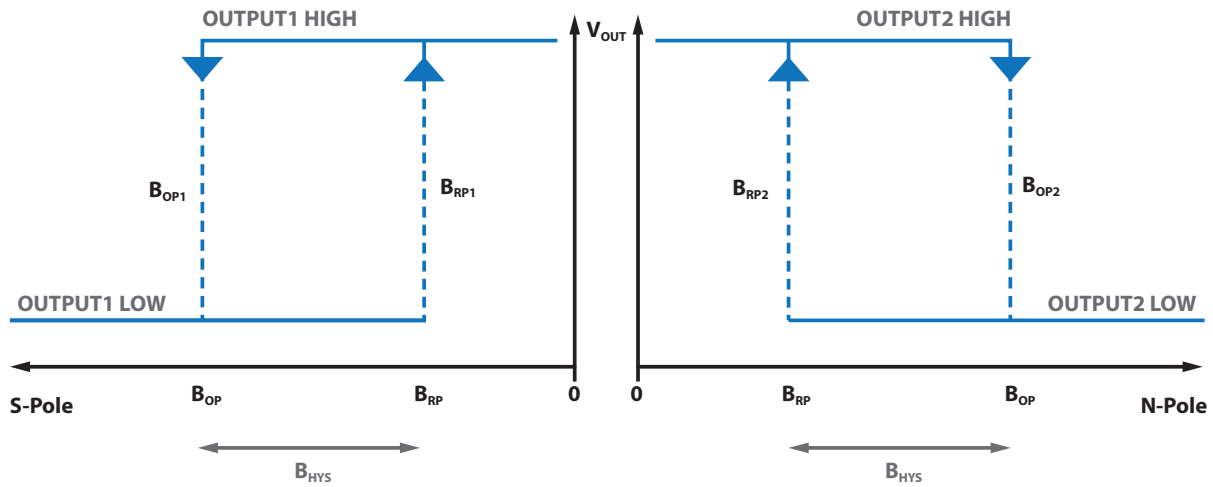

## 23 Output Behavior vs. Magnetic Field Diagrams

### 23.1 Output Behavior vs. Magnetic Field - Omnipolar

Characteristics	Conditions	Output
South Pole	$B < B_{OPS}$ $0 > B > B_{RPS}$	Low (ON) High (OFF)
North Pole	$B > B_{OPN}$ $0 < B < B_{RPN}$	Low (ON) High (OFF)

### 23.2 Output Behavior vs. Magnetic Field - Bipolar

Characteristics	Conditions	Output
South Pole	$B < B_{OPS}$	Low (ON)
North Pole	$B > B_{RPN}$	High (OFF)

### 23.3 Output Behavior vs. Magnetic Field - Unipolar (Dual Output)

#### OUTPUT2: North Field

Characteristics	Conditions	Output
South Field	$B > B_{OP}$	High (OFF)
Null or Weak Magnetic Field	$B < B_{RP}$	High (OFF)
North Field	$B > B_{OP}$	Low (ON)

#### OUTPUT1: South Field

Characteristics	Conditions	Output
North Field	$B > B_{OP}$	High (OFF)
Null or Weak Magnetic Field	$B < B_{RP}$	High (OFF)
South Field	$B > B_{OP}$	Low (ON)

## 24 TMR Sensor & Switch Packaging

### 24.1 SOT-23-3 Tape & Reel Packaging

Standard packaging is Tape & Reel containing 3,000 pieces. MSL Rating is 1.

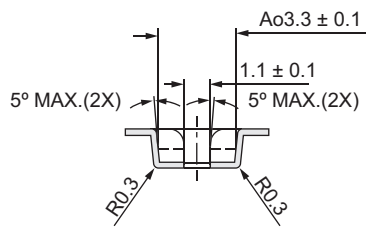
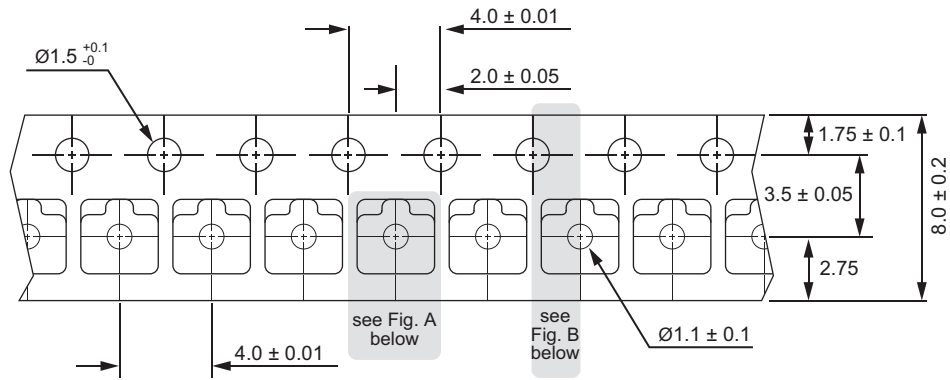

Fig. A

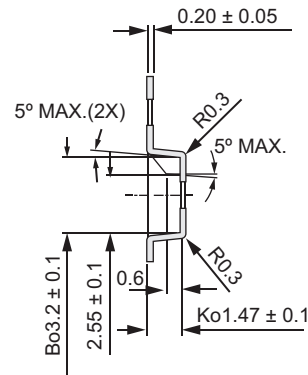
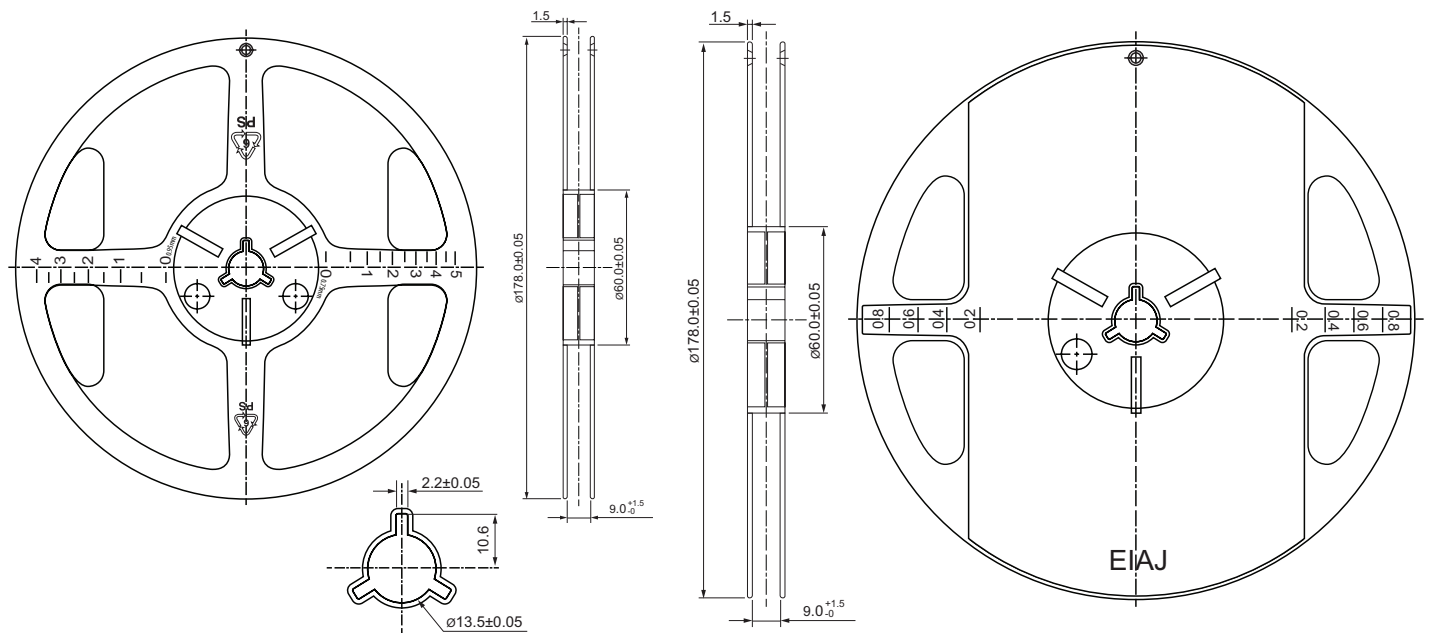

Fig. B



## 24 TMR Sensor & Switch Packaging

### 24.2 LGA-4 & Leaded LGA-4 Tape & Reel Packaging

Standard packaging is Tape & Reel containing 3,000 pieces. MSL Rating is 3.

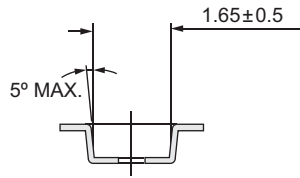
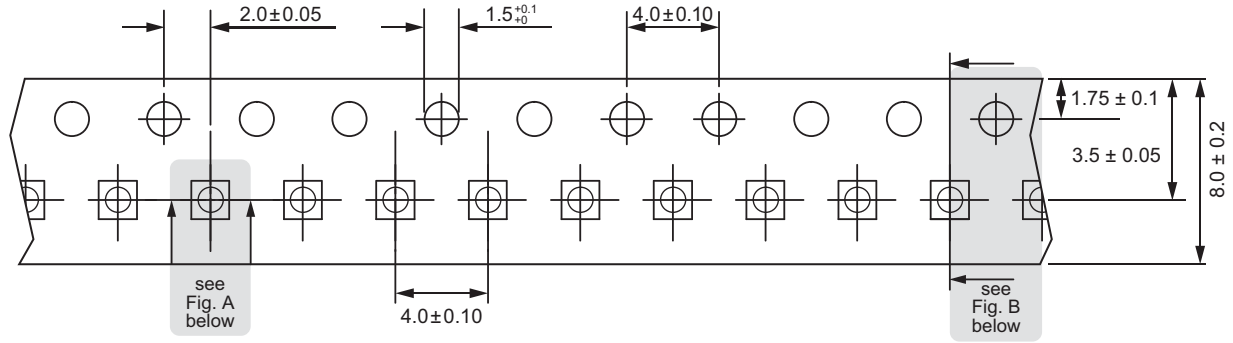

Fig. A

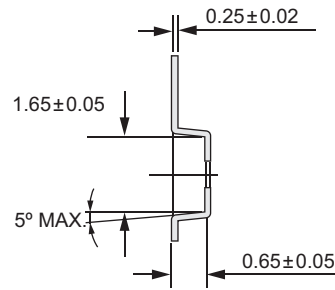
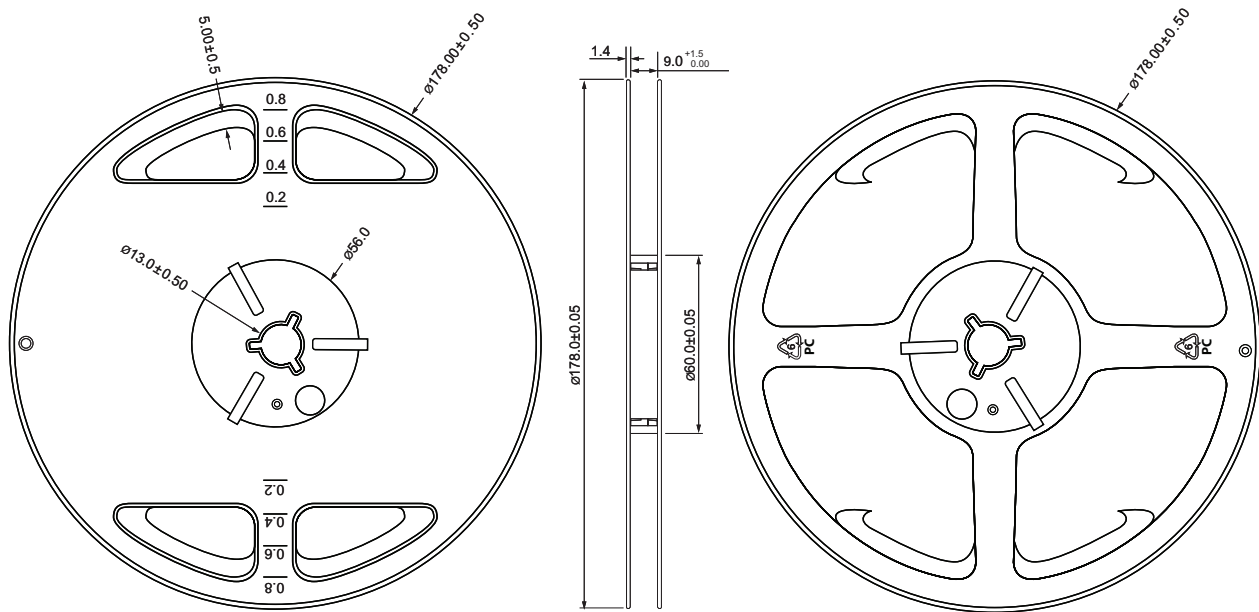

Fig. B



## 24 TMR Sensor & Switch Packaging

### 24.3 RedRock TMR Packaging

#### Box Dimensions – 14x10x6 inches

- Fits 1 to 3 reels = 3000 to 9000 pcs
- Weight for 3000 pcs = 0.90 kilos
- Weight for 9000 pcs = 1.00 kilos

#### Box Dimensions – 18x14x12 inches

- Fits 4 to 24 reels = 12000 to 72000 pcs
- Weight for 12000 pcs = 1.50 kilos
- Weight for 72000 pcs = 4.90 kilos

## 25 Suggested Pb-Free Reflow Profile

### Notes:

1. Fully compatible with standard no-lead solder profile, 260 °C for 30 seconds max (3 cycles max).
2. Profile shown as example. Users are advised to develop their own board-level profile.
3. Suggested Pb-free reflow profile derived from IPC/JEDEC J-STD-020E.
4. Temperature tolerance: +0 °C, as measured at any point on the package or leads
5. MSL rating of 1 (SOT-23-3 only) compatible with J-STD-020 or equivalent.
6. MSL rating of 3 (LGA-4 and Leaded LGA-4) compatible with J-STD-020 or equivalent.
7. All temperatures refer to the center of the package, measured on the package body surface that is facing up during assembly reflow (e.g., live-bug). If parts are reflowed in other than the normal live bug assembly reflow orientation (i.e., dead-bug), Tp shall be within ± 2 °C of the live bug Tp and still meet the Tc requirements, otherwise, the profile shall be adjusted to achieve the latter. To accurately measure actual peak package body temperatures, refer to JEP140 for recommended thermocouple use.
8. Reflow profiles in this document are for classification/preconditioning and are not meant to specify board assembly profiles. Actual board assembly profiles should be developed based on specific process needs and board designs and should not exceed the parameters in this table.

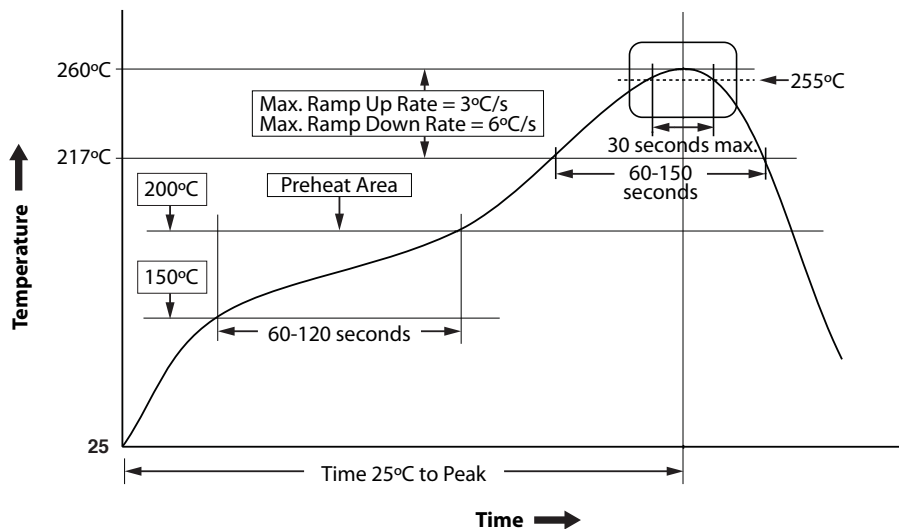

## 26 Suggested Solder Pad Layout

Dimensions in mm (inches)

### 26.1 SOT -23-3 Solder Pad Layout

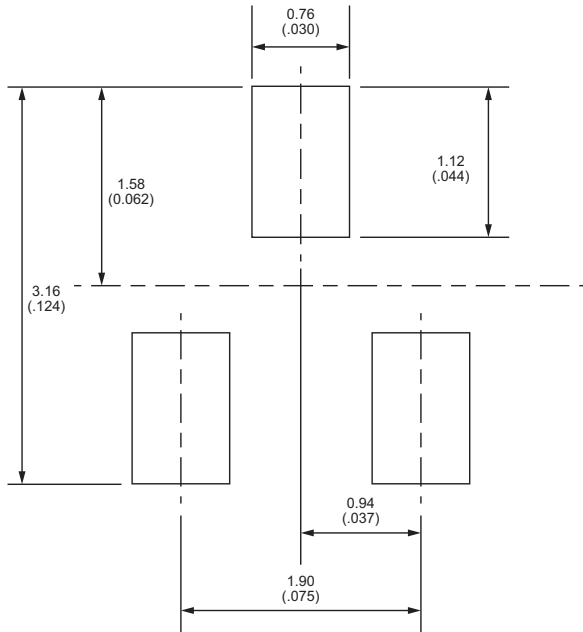

### 26.2 LGA-4 Solder Pad Layout

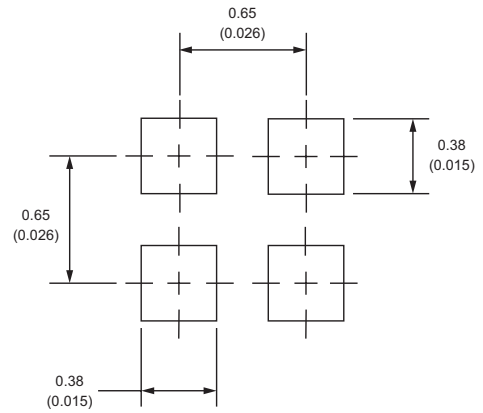

### 26.3 Leaded LGA-4 Solder Pad Layout

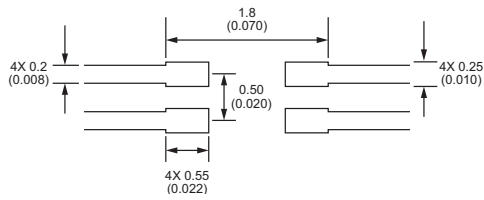

## Looking for pricing, stock, or lifecycle information?

Click below to explore more details on WIN SOURCE:

 [View RR121-1B13-311](#) on WIN SOURCE

 [Coto Technology](#) Information

## Optimize Your Supply Chain with WIN SOURCE Solutions

-  Global Sourcing Solution
-  Obsolete Management
-  Cost Control Management
-  Shortage Management
-  Alternative Solution
-  Excess Inventory Management