



**THE DATASHEET OF
ADM3095EBRZ**



FEATURES

- Certified Level 4 EMC protection on RS-485 A and B bus pins**
- IEC 61000-4-5 surge protection (± 4 kV)**
- IEC 61000-4-4 EFT protection (± 2 kV)**
- IEC 61000-4-2 ESD protection**
- ± 8 kV contact discharge**
- ± 15 kV air gap discharge**
- Certified IEC 61000-4-6 conducted RF immunity (10 V/m rms)**
- RS-485 A and B bus pins HBM ESD $> \pm 30$ kV**
- ± 42 V ac/dc peak fault protection on RS-485 bus pins**
- TIA/EIA RS-485 compliant over full supply range**
- 3.0 V to 5.5 V operating voltage range on V_{CC}**
- 1.62 V to 5.5 V V_{IO} logic supply**
- Common-mode input range: -25 V to $+25$ V**
- 2.5 Mbps data rate, maximum**
- Half duplex**
- PROFIBUS compliant at 4.5 V V_{CC}**
- Receiver short-circuit, open-circuit, and floating input fail-safe**
- Supports 256 bus nodes (96 k Ω receiver input resistance)**
- -40°C to $+125^{\circ}\text{C}$ temperature option**
- Glitch free power-up and power-down (hot swap)**
- 16-lead narrow body SOIC package**

APPLICATIONS

- Heating ventilation and air conditioning (HVAC) networks**
- Industrial field buses**
- Building automation**
- Utility networks**

GENERAL DESCRIPTION

The [ADM3095E](#) is a 3.0 V to 5.5 V, 2.5 Mbps, RS-485 transceiver that features up to ± 42 V ac/dc peak bus overvoltage fault protection on the RS-485 bus pins. This device is designed to withstand overvoltage faults, such as short circuits directly to power supplies, and overvoltage faults, such as ± 24 V ac supplies connected in error to the RS-485 A and B bus pins. The [ADM3095E](#) is an RS-485 transceiver that integrates IEC 61000-4-5 Level 4 surge protection, allowing up to ± 4 kV protection on the RS-485 bus pins. The device has IEC 61000-4-4 Level 4 electrical fast transient (EFT) protection up to ± 2 kV, and IEC 61000-4-2 Level 4 electrostatic discharge (ESD) protection on the bus pins, allowing the device to withstand up to ± 15 kV on the transceiver interface pins without latch-up or damage.

This device has an extended common-mode input voltage range of ± 25 V to improve data communication reliability in noisy environments over long cable lengths where ground loop voltages are possible. The combination of extended common-mode input voltage range, overvoltage fault protection, surge protection, EFT protection, and ESD protection make the [ADM3095E](#) a completely integrated electromagnetic compatibility (EMC) protected RS-485 transceiver.

The [ADM3095E](#) also features a logic supply pin, V_{IO} , for a flexible digital interface, operational to voltages as low as 1.62 V. The [ADM3095E](#) is PROFIBUS[®] compliant with a high driver differential output voltage, V_{OD} , of 2.1 V minimum at power supply voltages greater than 4.5 V. The device is fully characterized over extended operating temperature ranges, with options of -40°C to $+125^{\circ}\text{C}$, and is available in a 16-lead, narrow body SOIC package.

FUNCTIONAL BLOCK DIAGRAM

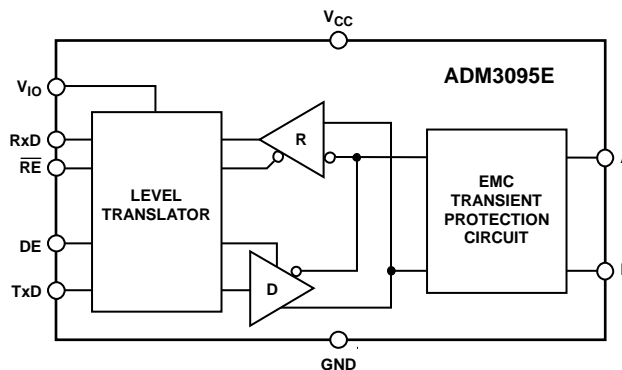

Figure 1.

TABLE OF CONTENTS

Features	1	Overvoltage Fault Protection	11
Applications	1	±42 V Miswire Protection	11
General Description	1	RS-485 Network Biasing and Termination	12
Functional Block Diagram	1	IEC ESD, EFT, and Surge Protection	12
Revision History	2	IEC 61000-4-6 Conducted RF Immunity	15
Specifications	3	Fully RS-485 Compliant over an Extended ±25 V Common-Mode Range	16
Timing Specifications	4	1.62 V to 5.5 V V _{IO} Logic Supply	16
Timing Diagrams	4	Truth Tables	16
Absolute Maximum Ratings	5	Receiver Fail-Safe	17
Thermal Resistance	5	RS-485 Data Rate and Bus Capacitance	17
ESD Caution	5	Hot Swap Capability	17
Pin Configuration and Function Descriptions	6	Applications Information	18
Typical Performance Characteristics	7	Robust Half Duplex RS-485 Network	18
Test Circuits	10	Outline Dimensions	19
Theory of Operation	11	Ordering Guide	19
RS-485 with Robustness	11		
Certified IEC EMC Solution	11		
REVISION HISTORY			
7/2017—Rev. B to Rev. C			
Changes to Supply Current (I _{CC}) Parameter, Table 1	3		
6/2017—Rev. A to Rev. B			
Changes to All Pins Parameter, Table 3	5		
5/2017—Rev. 0 to Rev. A			
Change to All Pins Parameter, Table 3	5		
3/2017—Revision 0: Initial Version			

SPECIFICATIONS

$V_{CC} = 3.0\text{ V to }5.5\text{ V}$, $T_A = T_{MIN} (-40^\circ\text{C})$, to $T_{MAX} (125^\circ\text{C})$, unless otherwise noted.

Table 1.

Parameter	Min	Typ	Max	Unit	Test Conditions/Comments
DRIVER					
Differential Output Voltage (V_{OD})	1.5		5.0	V	$V_{CC} \geq 3.0\text{ V}$, $R = 27\ \Omega$ or $50\ \Omega$; see Figure 25
	2.1		5.0	V	$V_{CC} \geq 4.5\text{ V}$, $R = 27\ \Omega$ or $50\ \Omega$; see Figure 25
Differential Output Voltage over Common Mode Range [V_{OD3}]	1.5		5.0	V	$V_{CC} \geq 3.0\text{ V}$, $V_{CM} = -25\text{ V to }+25\text{ V}$; see Figure 26
	2.1		5.0	V	$V_{CC} \geq 4.5\text{ V}$, $V_{CM} = -25\text{ V to }+25\text{ V}$; see Figure 26
$\Delta V_{OD} $ for Complementary Output States			0.2	V	$R = 27\ \Omega$ or $50\ \Omega$; see Figure 25
Common-Mode Output Voltage (V_{OC})			3	V	$R = 27\ \Omega$ or $50\ \Omega$; see Figure 25
$\Delta V_{OC} $ for Complementary Output States			0.2	V	$R = 27\ \Omega$ or $50\ \Omega$; see Figure 25
Output Short-Circuit Current, V_{OUT}					
High	-250		+250	mA	$-42\text{ V} \leq V_{SC}^1 \leq +42\text{ V}$
Low	-250		+250	mA	$-42\text{ V} \leq V_{SC}^1 \leq +42\text{ V}$
DRIVER INPUT LOGIC					
Input Logic Threshold Low			$0.33 V_{IO}$	V	$1.62\text{ V} \leq V_{IO} \leq 5.5\text{ V}$
Input Logic Threshold High	$0.7 V_{IO}$			V	$1.62\text{ V} \leq V_{IO} \leq 5.5\text{ V}$
Logic Input Current			± 1	μA	$0 \leq V_{IN} \leq V_{IO}$
RECEIVER					
Differential Input Threshold Voltage (V_{TH})	-200	-125	-30	mV	$-25\text{ V} \leq V_{CM} \leq +25\text{ V}$
Input Hysteresis (ΔV_{TH})		30		mV	$-25\text{ V} \leq V_{CM} \leq +25\text{ V}$
Input Resistance (A, B)	96			k Ω	$-25\text{ V} \leq V_{CM} \leq +25\text{ V}$
Input Capacitance (A, B)		150		pF	$T_A = 25^\circ\text{C}$
Input Current (A, B)	-1.0		+1.0	mA	$DE = 0\text{ V}$, $V_{CC} = 0\text{ V or }5\text{ V}$, $V_{IN} = \pm 25\text{ V}$
	-1.0		+1.0	mA	$DE = 0\text{ V}$, $V_{CC} = 0\text{ V or }5\text{ V}$, $V_{IN} = \pm 42\text{ V}$
CMOS Logic Input Current (\overline{RE})			± 1	μA	
Output Voltage					
Low (V_{OL})			0.2	V	$I_{OUT} = 300\ \mu\text{A}$
High (V_{OH})	$V_{IO} - 0.2$			V	$V_{IO} \geq 1.62\text{ V}$, $I_{OUT} = -300\ \mu\text{A}$
Output Short-Circuit Current	4		85	mA	$V_{OUT} = \text{GND or } V_{IO}$, $\overline{RE} = 0\text{ V}$, $V_{IO} \geq 3.0\text{ V}$
			85	mA	$V_{OUT} = \text{GND}/V_{IO}$, $\overline{RE} = 0\text{ V}$, $V_{IO} < 3.0\text{ V}$
Three-State Output Leakage Current			± 2	μA	$\overline{RE} = V_{IO}$, $RxD = 0\text{ V or }V_{IO}$
POWER SUPPLY					
V_{IO}	1.62		V_{CC}	V	
Supply Current (I_{CC})			8	mA	No load, $DE = V_{CC} = V_{IO}$, $\overline{RE} = 0\text{ V}$
TxD Data Rate = 2.5 Mbps			50	mA	No load, $DE = V_{CC} = V_{IO}$, $\overline{RE} = V_{CC} = V_{IO}$
RxD Data Rate = 2.5 Mbps			6	mA	No load, $DE = 0\text{ V}$, $\overline{RE} = 0\text{ V}$
TxD/RxD Data Rate = 2.5 Mbps			90	mA	No load, $DE = V_{CC} = V_{IO}$, $\overline{RE} = 0\text{ V}$
TxD/RxD Data Rate = 2.5 Mbps			130	mA	$R_L = 54\ \Omega$, $DE = V_{CC} = V_{IO}$, $\overline{RE} = 0\text{ V}$
			90	mA	$R_L = 54\ \Omega$, $DE = V_{CC} = V_{IO}$, $\overline{RE} = 0\text{ V}$, $V_{CC} = 5.5\text{ V}$
			45	mA	$R_L = 54\ \Omega$, $DE = V_{CC} = V_{IO}$, $\overline{RE} = 0\text{ V}$, $V_{CC} = 3.0\text{ V}$
Supply Current in Shutdown Mode			5	μA	$DE = 0\text{ V}$, $\overline{RE} = V_{CC} = V_{IO}$

¹ V_{SC} is the short-circuit voltage at the RS-485 A or B bus pin.

TIMING SPECIFICATIONS

$V_{CC} = 3.0\text{ V to }5.5\text{ V}$, $V_{IO} = 1.62\text{ V to }V_{CC}$, $T_A = T_{MIN} (-40^\circ\text{C})$, to $T_{MAX} (125^\circ\text{C})$, unless otherwise noted.

Table 2.

Parameter	Min	Typ	Max	Unit	Test Conditions/Comments
DRIVER					
Data Rate			2.5	Mbps	
Propagation Delay (t_{PLH} , t_{PHL})		35	500	ns	$R_{LDIFF} = 54\ \Omega$, $C_{L1} = C_{L2} = 100\text{ pF}$; see Figure 2 and Figure 27
Differential Skew (t_{SKEW})		10	50	ns	$R_{LDIFF} = 54\ \Omega$, $C_{L1} = C_{L2} = 100\text{ pF}$; see Figure 2 and Figure 27
Rise/Fall Times (t_r , t_f)		40	130	ns	$R_{LDIFF} = 54\ \Omega$, $C_{L1} = C_{L2} = 100\text{ pF}$; see Figure 2 and Figure 27
Enable Time (t_{ZH} , t_{ZL})		500	2500	ns	$R_L = 110\ \Omega$, $C_L = 50\text{ pF}$, see Figure 4 and Figure 28
Disable Time (t_{HZ} , t_{LZ})		500	2500	ns	$R_L = 110\ \Omega$, $C_L = 50\text{ pF}$, see Figure 4 and Figure 28
Enable Time from Shutdown		4000	5500	ns	$R_L = 110\ \Omega$, $C_L = 50\text{ pF}$, see Figure 4 and Figure 28
RECEIVER					
Propagation Delay (t_{PLH} , t_{PHL})		120	200	ns	$C_L = +15\text{ pF}$, $V_{ID}^1 \geq \pm 1.5\text{ V}$; see Figure 3 and Figure 29
		140	220	ns	$C_L = +15\text{ pF}$, $V_{ID}^1 \geq \pm 600\text{ mV}$; see Figure 3 and Figure 29
Skew (t_{SKEW})		4	40	ns	$C_L = +15\text{ pF}$, $V_{ID}^1 \geq \pm 1.5\text{ V}$; see Figure 3 and Figure 29
Enable Time		12	55	ns	$R_L = 1\text{ k}\Omega$, $C_L = 15\text{ pF}$; see Figure 5 and Figure 30
Disable Time		12	55	ns	$R_L = 1\text{ k}\Omega$, $C_L = 15\text{ pF}$; see Figure 5 and Figure 30
Enable Time from Shutdown		3000	4500	ns	$R_L = 1\text{ k}\Omega$, $C_L = 15\text{ pF}$; see Figure 5 and Figure 30
Time to Shutdown	50	330	3000	ns	$R_L = 1\text{ k}\Omega$, $C_L = 15\text{ pF}$; see Figure 5 and Figure 30
Rx, Pulse Width Distortion			40	ns	$C_L = +15\text{ pF}$, $V_{ID}^1 \geq \pm 1.5\text{ V}$; see Figure 3 and Figure 29

¹ V_{ID} is the input differential voltage to the RS-485 receiver.

TIMING DIAGRAMS

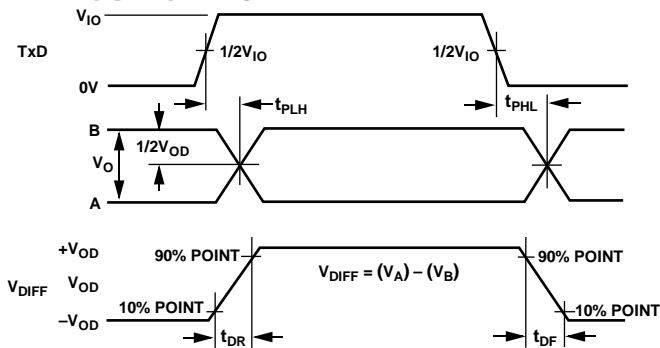

NOTES

- V_{OD} IS THE DIFFERENCE BETWEEN A AND B, WITH $+V_{OD}$ BEING THE MAXIMUM POINT OF V_{OD} , AND $-V_{OD}$ BEING THE MINIMUM POINT OF V_{OD} .

Figure 2. Driver Propagation Delay, Rise/Fall Timing Diagram

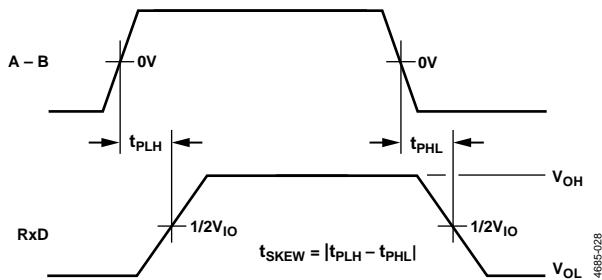

Figure 3. Receiver Propagation Delay Timing Diagram

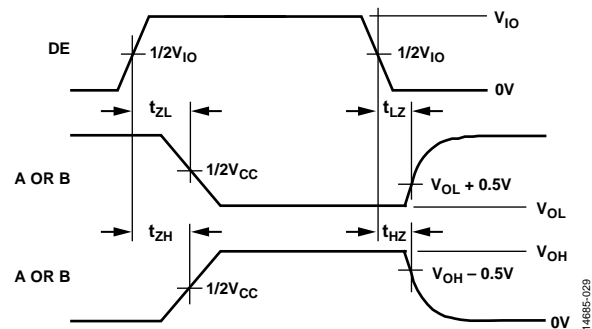

Figure 4. Driver Enable/Disable Timing Diagram

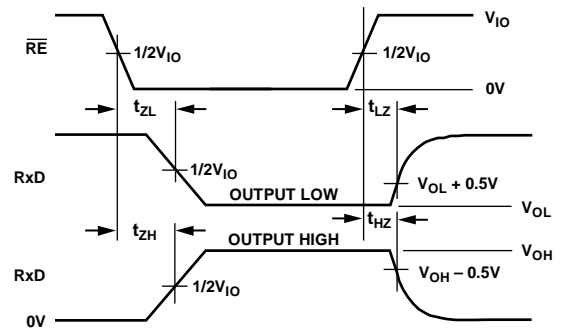

Figure 5. Receiver Enable/Disable Timing Diagram

ABSOLUTE MAXIMUM RATINGS

$T_A = 25^\circ\text{C}$, unless otherwise noted.

Table 3.

Parameter	Rating
V_{CC} to GND	-0.5 V to +7 V
V_{IO} to GND	-0.5V to +7 V
Digital Input/Output Voltage (DE, \overline{RE} , TxD, RxD)	-0.3 V to $V_{IO} + 0.3$ V
Driver Output/Receiver Input Voltage	± 48 V
Operating Temperature Range	-40°C to +125°C
Storage Temperature Range	-65°C to +150°C
Maximum Junction Temperature	150°C
Continuous Total Power Dissipation	400 mW
Lead Temperature	
Soldering (10 sec)	300°C
Vapor Phase (60 sec)	215°C
Infrared (15 sec)	220°C
ESD (A Pin and B Pin Only)	
IEC 61000-4-2 Contact Discharge	± 8 kV
IEC 61000-4-2 Air Discharge	± 15 kV
EFT (A Pin and B Pin Only)	
IEC 61000-4-4 Level 4 EFT	± 2 kV
Surge (A Pin and B Pin Only)	
IEC 61000-4-5 Level 4 Surge	± 4 kV
Human Body Model (HBM) ESD Protection	
All Pins	± 4 kV
A Pin and B Pin Only	$> \pm 30$ kV
Field Induced Charged Device Model ESD (FICDM)	± 1.25 kV

Stresses at or above those listed under Absolute Maximum Ratings may cause permanent damage to the product. This is a stress rating only; functional operation of the product at these or any other conditions above those indicated in the operational section of this specification is not implied. Operation beyond the maximum operating conditions for extended periods may affect product reliability.

THERMAL RESISTANCE

Table 4. Thermal Resistance

Package Type	θ_{JA}^1	θ_{JC}^1	Unit
R-16	50.9	18.9	$^\circ\text{C}/\text{W}$

¹ Thermal impedance simulated values are based on JEDEC 2S2P thermal test board with no vias. See JEDEC JESD51.

ESD CAUTION



ESD (electrostatic discharge) sensitive device. Charged devices and circuit boards can discharge without detection. Although this product features patented or proprietary protection circuitry, damage may occur on devices subjected to high energy ESD. Therefore, proper ESD precautions should be taken to avoid performance degradation or loss of functionality.

PIN CONFIGURATION AND FUNCTION DESCRIPTIONS

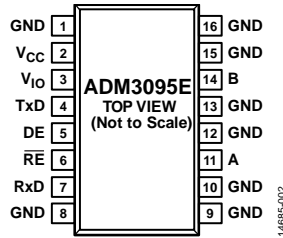

Figure 6. Pin Configuration

Table 5. Pin Descriptions

Pin No.	Mnemonic	Description
1, 8 to 10, 12, 13, 15, 16	GND	Ground.
2	V _{CC}	3.0 V to 5.5 V Power Supply. It is recommended that a 0.1 μF decoupling capacitor is added between Pin V _{CC} and Pin GND.
3	V _{IO}	1.62 V to 5.5 V V _{IO} Logic Supply. It is recommended that a 0.1 μF decoupling capacitor is added between Pin V _{IO} and Pin GND.
4	TxD	Transmit Data Input. Data transmitted by the driver is applied to this input.
5	DE	Driver Output Enable. A high level on this pin enables the A and B driver differential outputs. A low level places them into a high impedance state.
6	RE	Receiver Enable Input. This is an active low input. Driving this input low enables the receiver and driving the input high disables the receiver.
7	RxD	Receiver Output Data. This output is high when (A – B) > –30 mV and low when (A – B) < –200 mV.
11	A	Noninverting Driver Output/Receiver Input. When the driver is disabled, or when V _{CC} is powered down, Pin A is put into a high impedance state to avoid overloading the bus.
14	B	Inverting Driver Output/Receiver Input. When the driver is disabled, or when V _{CC} is powered down, Pin B is put into a high impedance state to avoid overloading the bus.

TYPICAL PERFORMANCE CHARACTERISTICS

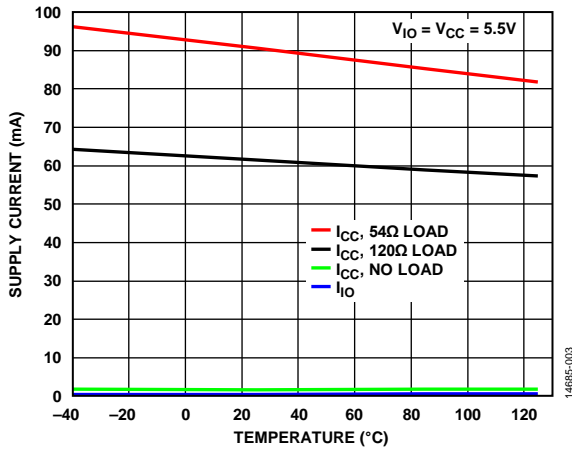

Figure 7. Supply Current vs. Temperature, Data Rate = 2.5 Mbps

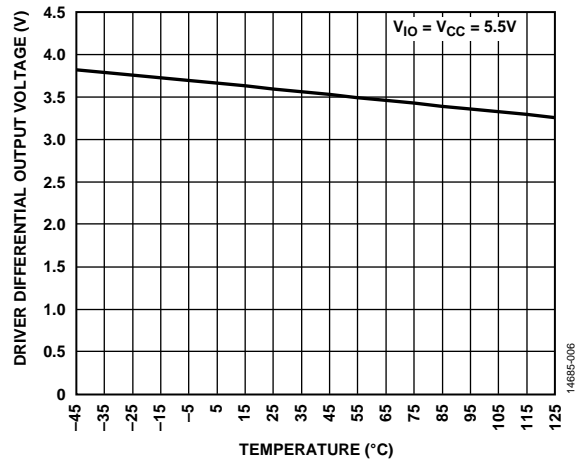

Figure 10. Driver Differential Output Voltage vs. Temperature

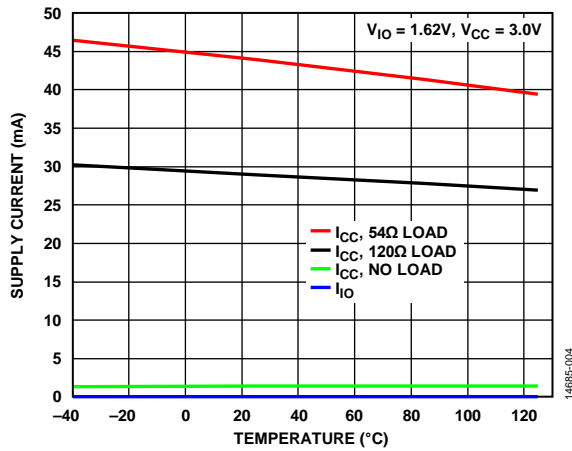

Figure 8. Supply Current vs. Temperature, Data Rate = 2.5 Mbps

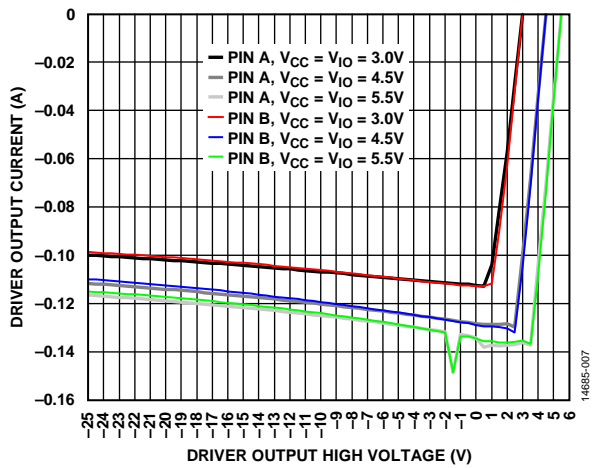

Figure 11. Driver Output Current vs. Driver Output High Voltage

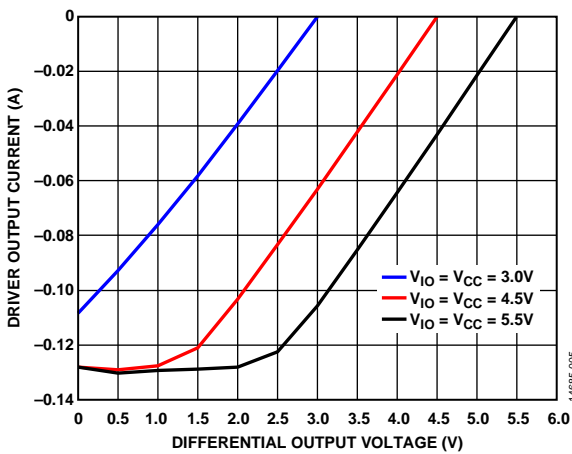

Figure 9. Driver Output Current vs. Differential Output Voltage

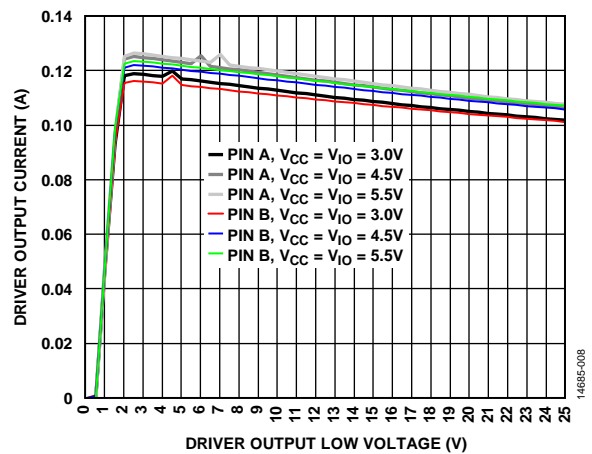

Figure 12. Driver Output Current vs. Driver Output Low Voltage

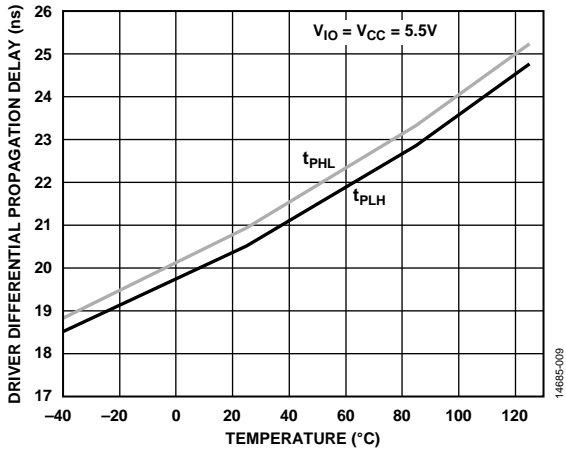

Figure 13. Driver Differential Propagation Delay vs. Temperature

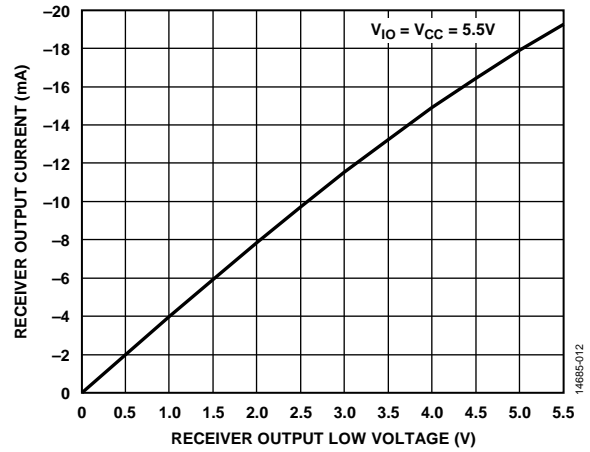

Figure 16. Receiver Output Current vs. Receiver Output Low Voltage

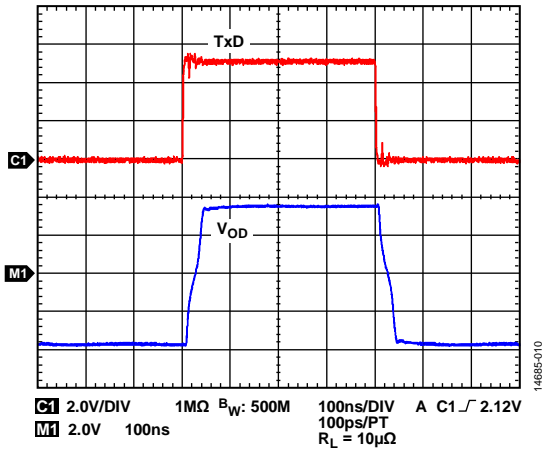

Figure 14. Driver Propagation Delay

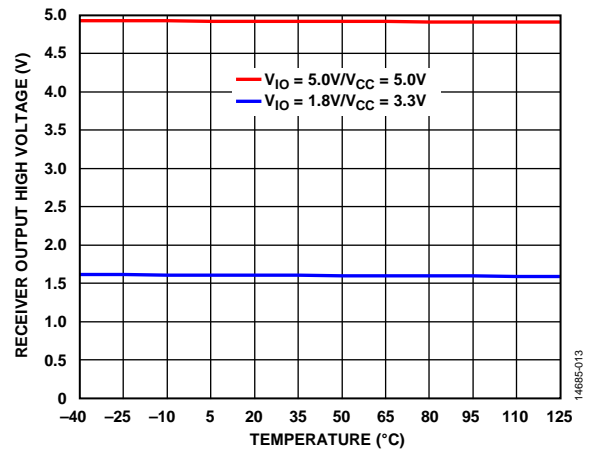

Figure 17. Receiver Output High Voltage vs. Temperature

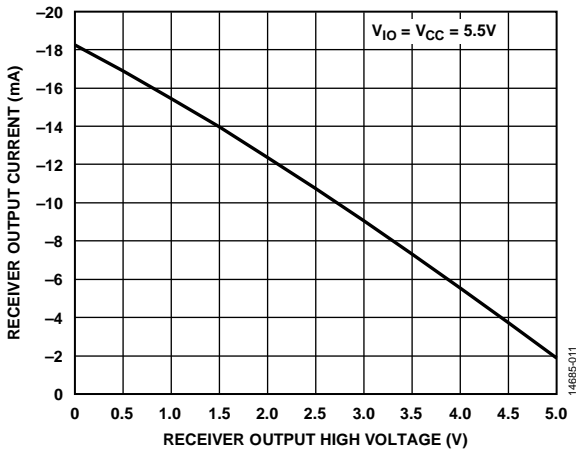

Figure 15. Receiver Output Current vs. Receiver Output High Voltage

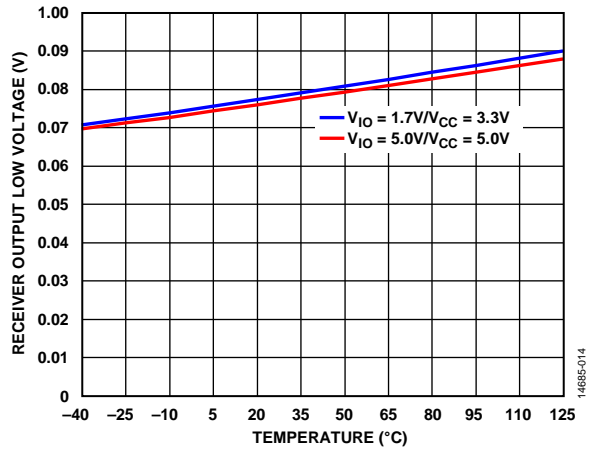

Figure 18. Receiver Output Low Voltage vs. Temperature

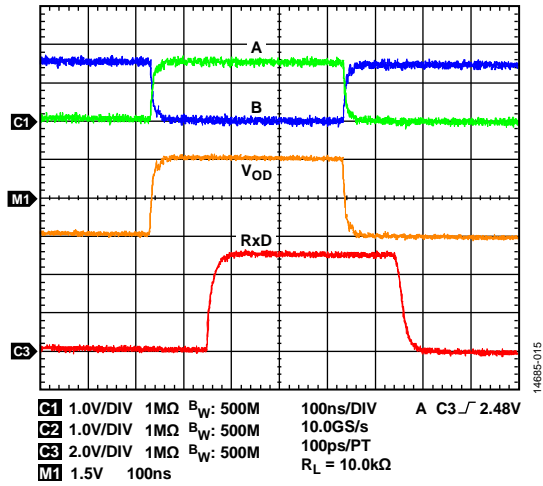

Figure 19. Receiver Propagation Delay

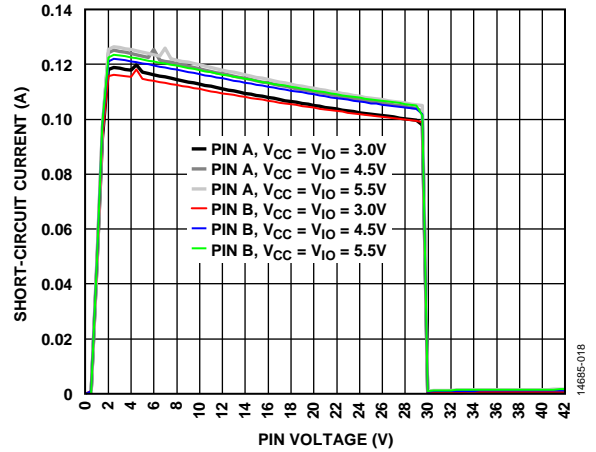

Figure 22. Short-Circuit Current vs. Pin Voltage

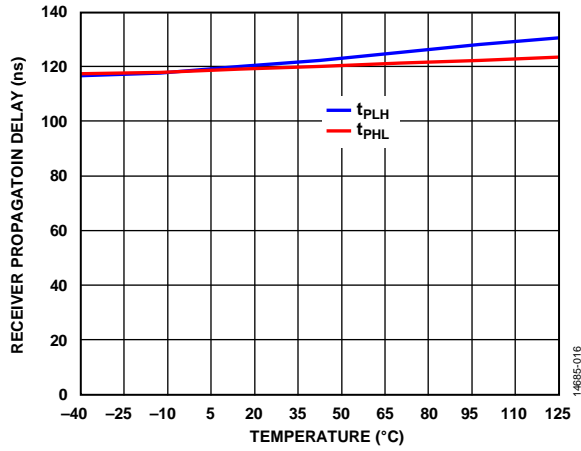

Figure 20. Receiver Propagation Delay vs. Temperature

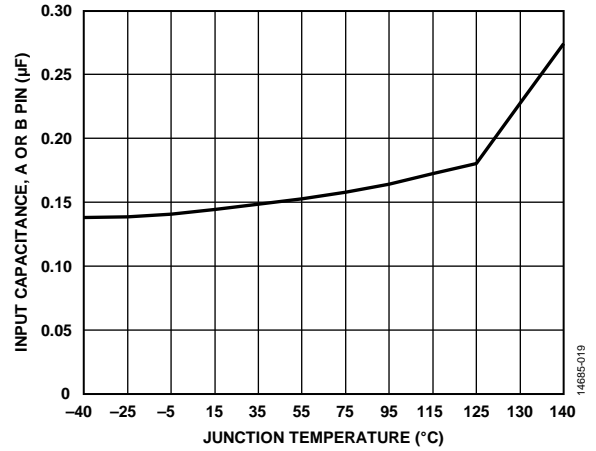

Figure 23. Input Capacitance, A or B Pin vs. Junction Temperature

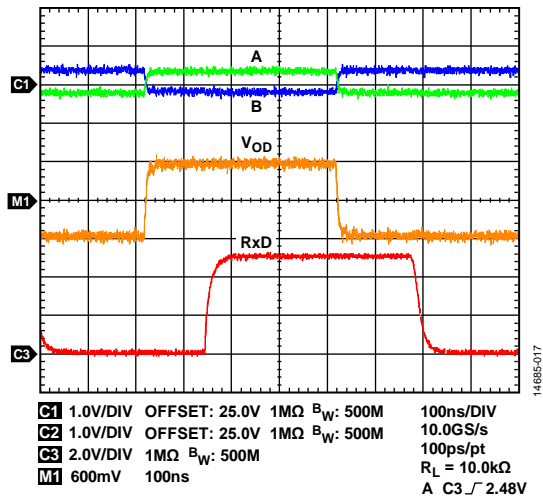

Figure 21. Receiver Performance with Input Common-Mode Voltage of 25V

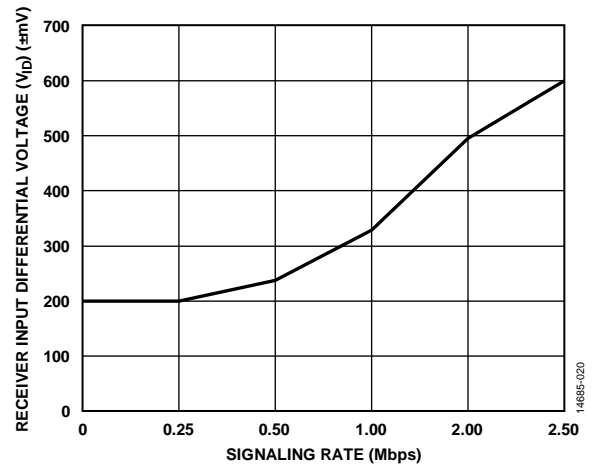

Figure 24. Receiver Input Differential Voltage (V_{ID}) vs. Signaling Rate

TEST CIRCUITS

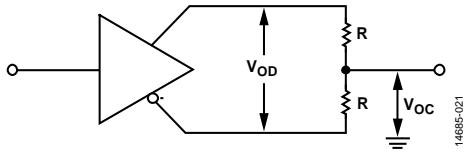

Figure 25. Driver Voltage Measurement

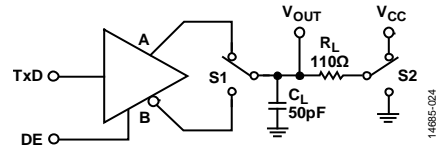

Figure 28. Driver Enable/Disable

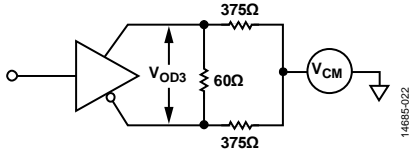

Figure 26. Driver Voltage Measurement over Common-Mode Voltage Range

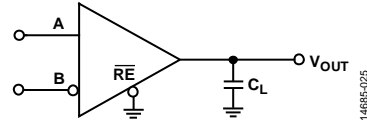

Figure 29. Receiver Propagation Delay

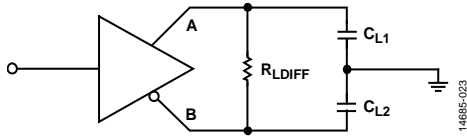

Figure 27. Driver Propagation Delay

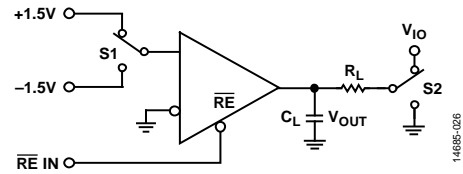

Figure 30. Receiver Enable/Disable

THEORY OF OPERATION

RS-485 WITH ROBUSTNESS

The [ADM3095E](#) is a 3.0 V to 5.5 V RS-485 transceiver with robustness that reduces system failures when operating in harsh application environments. The [ADM3095E](#) is an RS-485 transceiver that integrates IEC 61000-4-5 Level 4 surge protection, allowing up to ± 4 kV protection on the RS-485 bus pins without the need for external protection components, such as transient voltage suppressors (TVSs) or totally integrated surge protectors (TISPs). The [ADM3095E](#) has IEC 61000-4-4 Level 4 EFT protection up to ± 2 kV, IEC 61000-4-2 Level 4 ESD protection, and IEC 61000-4-5 surge protection for the bus pins. The [ADM3095E](#) also offers a defined level of overvoltage fault protection.

CERTIFIED IEC EMC SOLUTION

The driver outputs and receiver inputs of RS-485 devices often experience high voltage faults from short circuits to power supplies that exceed the -7 V to $+12$ V range specified in the Telecommunications Industry Association (TIA)/Electronic Industries Alliance (EIA) RS-485 standard. Typically, RS-485 applications require costly external protection devices, such as positive temperature coefficient (PTC) fuses, for operation in harsh electrical environments. System designers must also consider common EMC problems in these harsh electrical environments, choosing components to provide IEC 61000-4-2 ESD, IEC 61000-4-4 EFT, and IEC 61000-4-5 surge protection for the RS-485 bus pins.

When choosing suitable EMC protection components, achieving EMC regulations compliance and matching the EMC protection dynamic breakdown characteristics to the RS-485 transceiver can be challenging. To overcome these challenges, the designer can run multiple design, test, and printed circuit board (PCB) iterations; however, this leads to a slower time to market and project budget overruns.

To reduce system cost and design complexity, the [ADM3095E](#) provides integrated EMC and overvoltage fault protection. The [ADM3095E](#) integrated EMC and overvoltage fault protection circuits are optimally performance matched, saving the circuit designer significant design and testing time.

Figure 31 shows an EMC protected RS-485 circuit layout, which targets IEC 61000-4-2 ESD Level 4, IEC 61000-4-4 EFT Level 4, and IEC 61000-4-5 surge protection to Level 4 for RS-485 bus pins. This circuit uses several discrete components, including two TISPs, two transient blocking units (TBUs), and one dual TVS. Due to the integrated protection components of the [ADM3095E](#), the PCB area is significantly reduced when compared to a solution with discrete EMC and overvoltage fault protection components.

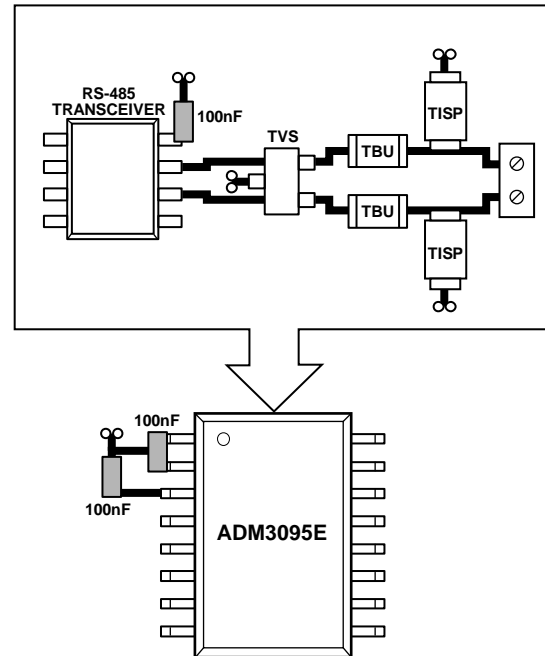

Figure 31. EMC Protected RS-485 Circuit Layout

OVERVOLTAGE FAULT PROTECTION

The [ADM3095E](#) is an RS-485 transceiver that offers fault protection over a 3.0 V to 5.5 V V_{CC} operating range without close examination of the RS-485 transceiver logic pin state (TxD input and DE/RE input). The transceiver is also fault protected over the entire extended common-mode operating voltage range of ± 25 V.

The [ADM3095E](#) RS-485 driver outputs and receiver inputs are protected from any voltages short circuiting within the -42 V to $+42$ V ac/dc peak range. The maximum current in a fault condition is ± 250 mA. The RS-485 driver includes a foldback current limiting circuit that reduces the driver current at voltages above the ± 25 V common-mode range limit of the transceiver (see Figure 22). Due to the foldback feature, this current reduction allows better management of power dissipation and heating effects.

± 42 V MISWIRE PROTECTION

The [ADM3095E](#) is protected against high voltage miswire events when it operates on a bus that does not have RS-485 termination or bus biasing resistors installed. A typical miswire event is when a high voltage 24 V ac/dc power supply is connected directly to the RS-485 bus pin connectors. The [ADM3095E](#) can withstand miswiring faults of up to ± 42 V peak on RS-485 bus pins with respect to ground (GND) without damage.

Figure 33 shows the 8 kV contact discharge current waveform as described in the Specifications section. Some of the key waveform parameters are rise times of less than 1 ns and pulse widths of approximately 60 ns.

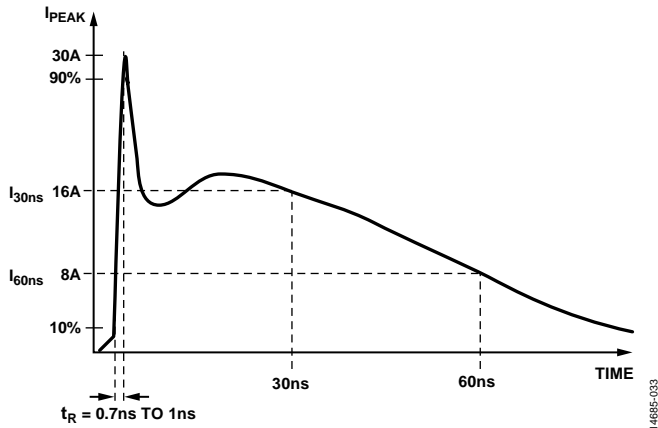

Figure 33. IEC 61000-4-2 ESD Waveform (8 kV)

Figure 34 shows the 8 kV contact discharge current waveform from the IEC 61000-4-2 standard compared to the hHBM ESD 8 kV waveform. The two standards specify a different waveform shape and peak current. The peak current associated with an IEC 61000-4-2 8 kV pulse is 30 A, while the corresponding peak current for HBM ESD is more than five times less at 5.33 A. The other difference is the rise time of the initial voltage spike, with IEC 61000-4-2 ESD having a much faster rise time of 1 ns, compared to the 10 ns associated with the HBM ESD waveform. The amount of power associated with an IEC 61000-4-2 ESD waveform is much greater than that of an HBM ESD waveform (see Figure 34).

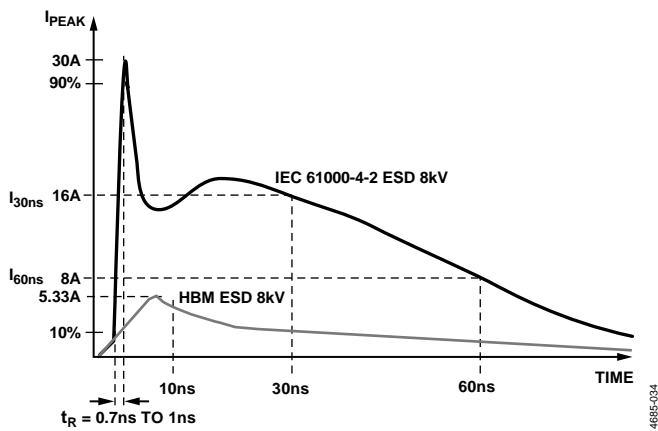

Figure 34. IEC 61000-4-2 ESD Waveform (8 kV) compared to the HBM ESD Waveform (8 kV)

These factors combined mean that it is strongly recommended for system designers to choose devices such as the ADM3095E with IEC 61000-4-2 ESD ratings for operation in harsh environments, rather than some competitive devices, which state varying levels of HBM ESD protection. Table 7 summarizes the IEC 61000-4-2 ESD certified test results. Testing was performed in normal transceiver operation with the ADM3095E clocking data at 2.0 Mbps. See Figure 35 for the IEC 61000-4-2 ESD testing diagram.

Table 7. IEC 61000-4-2 Certified Test Results

ESD Gun Connected to	IEC 61000-4-2 Test Result	Certified Result
GND	±15 kV (air), ±8 kV (contact), Level 4 protection	Yes

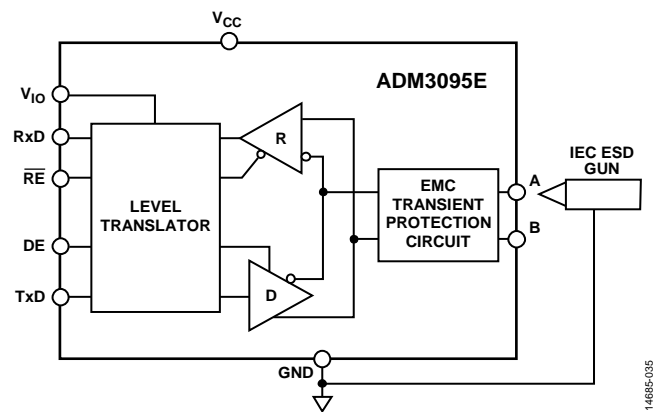

Figure 35. IEC 61000-4-2 ESD Testing Diagram

Electrical Fast Transients (EFT)

EFT testing involves coupling a number of extremely fast transient impulses onto the signal lines to represent transient disturbances associated with external switching circuits that are capacitively coupled onto the communication ports, which can include relay and switch contact bounce or transients originating from the switching of inductive or capacitive loads—all of which are very common in industrial environments. The EFT test defined in IEC 61000-4-4 attempts to simulate the interference resulting from these types of events.

Figure 36 shows the EFT 50 Ω load waveform. The EFT waveform is described in terms of a voltage across 50 Ω impedance from a generator with 50 Ω output impedance. The output waveform consists of a 15 ms burst of 2.5 kHz to 5 kHz high voltage transients repeated at 300 ms intervals (see Figure 36). Each individual pulse has a rise time of 5 ns and pulse duration of 50 ns, measured between the 50% point on the rising and falling edges of the waveform.

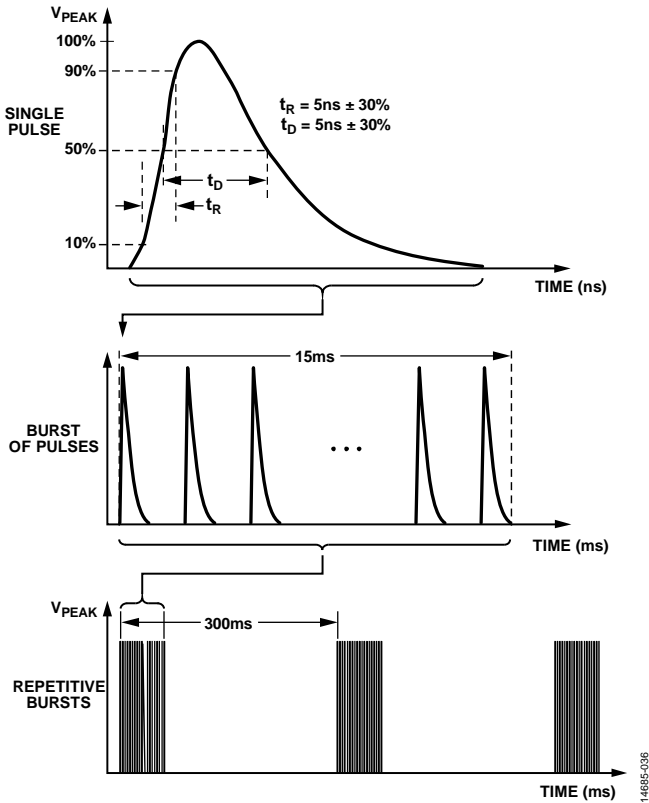

Figure 36. IEC 61000-4-4 EFT 50 Ω Load Waveforms

The total energy in a single EFT pulse is similar to that in an ESD pulse. The total energy in a single pulse is typically 4 mJ.

The ADM3095E is robust to IEC 61000-4-4 events and passes the highest level recognized in the standard Level 4, defining a voltage level of 2 kV.

During testing, these EFT fast burst transients are coupled onto the communication lines using a capacitive clamp. The EFT is capacitively coupled onto the communication lines by the clamp rather than direct contact. This coupling also reduces the loading caused by the low output impedance of the EFT generator. The coupling capacitance between the clamp and cable depends on cable diameter, shielding, and insulation on the cable. Testing was performed in normal transceiver operation, with the ADM3095E clocking data at 2.0 Mbps in two configurations: first, with a shielded twisted pair cable with the RS-485 cable shield connected to the GND pin; second, with a twisted pair cable with no shield. Table 8 summarizes the certified test results. See Figure 37 for the IEC 61000-4-4 EFT testing diagram.

Table 8. IEC 61000-4-4 Certified Test Results

EFT Clamp Connected to	IEC 61000-4-4 Test Result	Certified Result
GND	±2 kV Level 4 protection	Yes

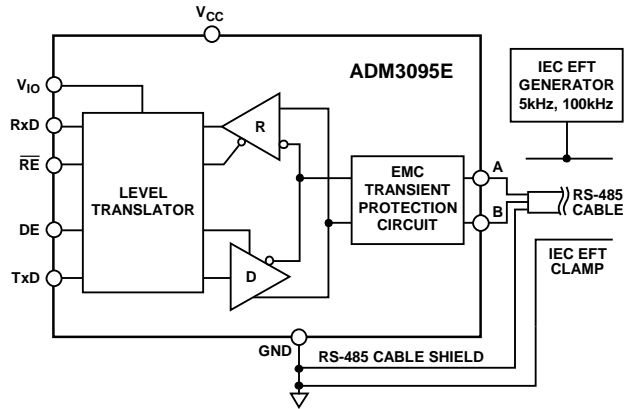

Figure 37. IEC 61000-4-4 EFT Testing Diagram

Surge Transients

Surge transients are caused by overvoltage from switching or lightning transients. Switching transients can result from power system switching, load changes in power distribution systems, or various system faults, such as short circuits. Lightning transients can be a result of high currents and voltages injected into the circuit from nearby lightning strikes. IEC 61000-4-5 defines waveforms, test methods, and test levels for evaluating immunity against these destructive surges.

The waveforms are specified as the outputs of a waveform generator in terms of open circuit voltage and short-circuit current. Figure 38 shows the 1.2 μs/50 μs waveform, which is used for RS-485 communications ports. The waveform generator has an effective output impedance of 2 Ω; therefore, the surge transient has high currents associated with it.

Figure 38 shows the 1.2 μs and 50 μs surge transient waveform. ESD and EFT have similar rise times, pulse widths, and energy levels; however, the surge pulse has a rise time of 1.25 μs and the pulse width is 50 μs (see Figure 38). Additionally, the surge pulse energy can reach almost 90 J, which is three to four orders of magnitude larger than the energy in an ESD or EFT pulse. Therefore, the surge transient is considered the most severe of the EMC transients.

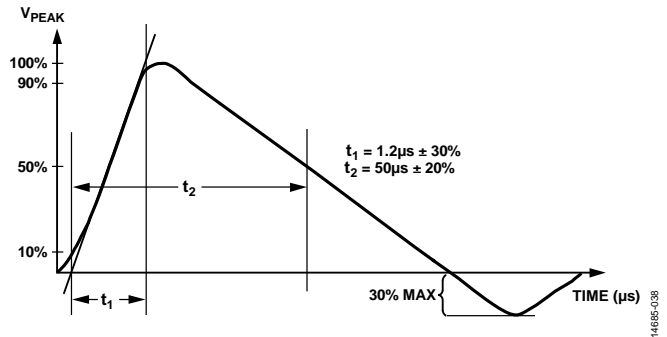

Figure 38. IEC 61000-4-5 Surge 1.2 μs and 50 μs Waveform

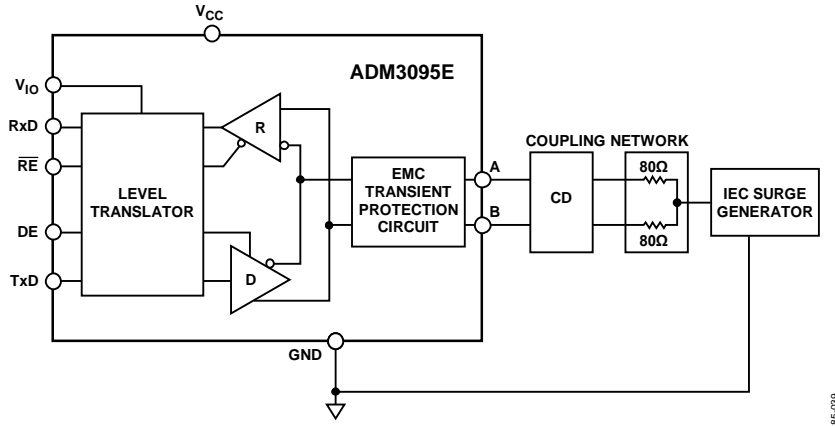

Figure 39. IEC 61000-4-5 Surge Testing Diagram

The [ADM3095E](#) is robust to IEC 61000-4-5 events and passes the highest level recognized in the standard Level 4, which defines a peak voltage of 4 kV.

Figure 39 shows a typical setup for testing the [ADM3095E](#) to the IEC 61000-4-5 surge standard. During testing, resistors couple the surge transient onto the communication line. The coupling network for a half duplex RS-485 device consists of an 80 Ω resistor on both the A and B pins. The total parallel sum of the resistance is 40 Ω. During the surge test, five positive and five negative pulses are applied to the data ports with a maximum time interval of one minute between each pulse. The IEC 61000-4-5 standard states the device must be set up in normal operating conditions for the duration of the test.

Testing was performed in normal transceiver operation, with the [ADM3095E](#) clocking data at 2.0 Mbps. Table 9 summarizes the certified test results.

Table 9. IEC 61000-4-5 Certified Test Results

Surge Generator Connected to	IEC 61000-4-5 Test Result	Certified Result
GND	±4 kV Level 4 protection	Yes

IEC 61000-4-6 CONDUCTED RF IMMUNITY

The [EVAL-ADM3095EEBZ](#) is lab tested and certified to pass IEC 61000-4-6 conducted radio frequency (RF) immunity testing to Level 3 (10 V/m rms). The IEC 61000-4-6 conducted immunity test is applicable to products that operate in environments where RF fields are present and are connected to the main power supplies or other networks (signal or control lines). The source of conducted disturbances are electromagnetic fields, emanating from RF transmitters that can act on the whole length of cables connected to installed equipment. In the IEC 61000-4-6 test, an RF voltage sweeps and steps from 150 kHz to 80 MHz. The RF voltage is amplitude modulated 80% at 1 kHz. The RF voltage is then applied to the equipment under test (EUT), one [EVAL-ADM3095EEBZ](#) using a clamp, as specified in Table 10. The clamp is placed on a communications cable between two [EVAL-ADM3095EEBZ](#) evaluation boards.

The [EVAL-ADM3095EEBZ](#) is tested to Level 3, which is the highest test level of 10 V/m rms. For all testing, the clamp, connecting cable, and the EUT setup is described in Table 10 and Figure 40. For all tests, the IEC 61000-4-6 clamp is placed at the [EVAL-ADM3095EEBZ](#) EUT, and the cable shield is either floating or earthed.

Table 10. IEC 61000-4-6 Conducted RF Immunity EUT and Equipment

Parameter	Details
IEC 61000-4-6 Clamp	Schaffner KEMZ 801, placed at 30 cm away from the EUT
IEC 61000-4-6 Test Level	Level 3, 0.15 MHz to 100 MHz, 10 V/m rms, 80% amplitude modulated by a 1 kHz sinusoidal
EUT	EVAL-ADM3095EEBZ
EUT Data Rate	2.0 Mbps
EUT Power	V _{CC} and V _{IO} powered at 5V
Cable Between EUT	5 meters, Unitronic PROFIBUS, 22 American wire gauge (AWG)
Cable Termination	120 Ω resistor at both cable ends
Pass/Fail Criteria	Passes if data at receiver with a pulse width distortion is within 10% of mean
Pass Classification	Class A compliance

The second [EVAL-ADM3095EEBZ](#) (auxiliary equipment) is placed on the network (consisting of both [EVAL-ADM3095EEBZ](#) devices) to terminate the communications bus. Table 11 shows the test results where the EUT passed IEC 61000-4-6 to Level 3. The [ADM3095E](#) in the cable shield setups outlined in Table 11 meet Class A compliance for the IEC 61000-4-6 conducted RF immunity standard. An unshielded twisted pair cable was also tested; see Table 11.

Table 11. IEC 61000-4-6 Conducted RF Immunity Certified Test Results

Clamp Location	Cable Shield	Current Return Path	IEC 61000-4-6 Test Frequency (MHz)	Certified Result
30 cm from EUT	Floating	GND	0.15 to 80	Pass
30 cm from EUT	Earthed	GND	0.15 to 80	Pass
30 cm from EUT	N/A ¹	GND	0.15 to 80	Pass

¹ N/A means not applicable.

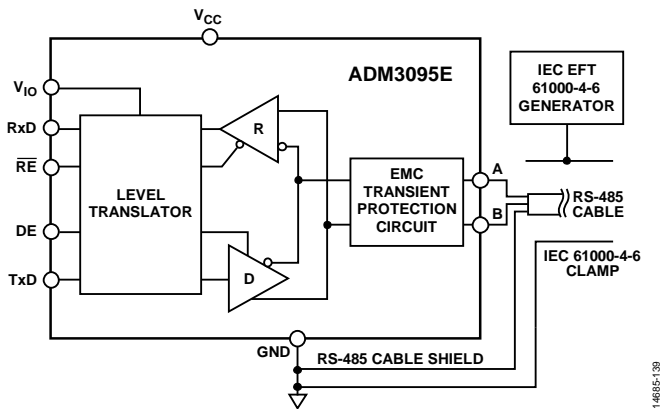

Figure 40. IEC 61000-4-6 Conducted RF Immunity Example Test Setup

FULLY RS-485 COMPLIANT OVER AN EXTENDED ±25 V COMMON-MODE RANGE

The [ADM3095E](#) is an RS-485 transceiver that offers an extended common-mode input range of ±25 V across an operating voltage range of 3.0 V to 5.5 V while still meeting or exceeding compliance with the TIA/EIA RS-485 standard. These standards specify a bus differential voltage of at least 1.5 V across the common-mode range. Additionally, when powered at greater than 4.5 V V_{CC} , the [ADM3095E](#) driver output is a minimum 2.1 V V_{OD} , meeting the requirements for a PROFIBUS compliant RS-485 driver.

The extended common-mode input range of ±25 V improves system robustness over long cable lengths, where large differences in ground potential between RS-485 transceivers are possible. The extended common-mode input range of ±25 V improves data communication reliability in noisy environments over long cable lengths where ground loop voltages are possible.

1.62 V TO 5.5 V V_{IO} LOGIC SUPPLY

The [ADM3095E](#) features a logic supply pin, V_{IO} , for a flexible digital interface operational to voltages as low as 1.62 V. The V_{IO} pin powers the logic inputs (TxD input and DE/ \overline{RE} control pins) and the RxD output.

These pins interface with logic devices such as universal asynchronous receivers/transmitters (UARTs), application specific integrated circuits (ASICs), and microcontrollers. Many of these devices use power supplies significantly lower than 5 V.

TRUTH TABLES

V_{IO} supplies the DE, TxD, \overline{RE} , and RxD interfaces only.

Table 12. Transmitting Truth Table

Supply Status		Inputs ¹		Outputs ¹	
V_{CC}	V_{IO}	DE	TxD	A	B
On	On	H	H	H	L
On	On	H	L	L	H
On	On	L	X	Z	Z
On	Off	H	H	I	I
On	Off	H	L	I	I
On	Off	L	X	I	I
Off	On	X	X	Z	Z
Off	Off	X	X	Z	Z

¹ H means high level; I means indeterminate; L means low level; X means any state; Z means high impedance (off).

Table 13. Receiving Truth Table

Supply Status		Inputs ¹	\overline{RE}	Outputs ¹
V_{CC}	V_{IO}	A – B		RxD
On	On	>–0.03 V	L	H
On	On	<–0.2 V	L	L
On	Off	>–0.03 V	L	I
On	Off	<–0.2 V	L	I
On	On	–0.2 V < A – B < –0.03 V	L	I
On	Off	–0.2 V < A – B < –0.03 V	L	I
On	On	Inputs open/shorted	L	H
On	Off	Inputs open/shorted	L	I
On	On	X	H	Z
On	Off	X	H	I
Off	Off	X	H	I
Off	Off	X	L or NC	I

¹ H means high level; I means indeterminate; L means low level; X means any state; Z means high impedance (off); NC means no connect.

RECEIVER FAIL-SAFE

The receiver input includes a fail-safe feature that guarantees a logic high RxD output when the A and B inputs are floating, open circuited, or shorted. A logic high RxD output is guaranteed in a terminated transmission line with all drivers disabled. This is done by setting the receiver input threshold between -30 mV and -200 mV. If the differential receiver input voltage ($A - B$) is greater than or equal to -30 mV, RxD is logic high. If $A - B$ is less than or equal to -200 mV, RxD is logic low. In the case of a terminated bus with all transmitters disabled, the receiver differential input voltage is pulled to 0 V by the termination. With the receiver thresholds of the ADM3095E, this results in a logic high with a 30 mV minimum noise margin.

The receiver fail-safe feature (logic high RxD) is also guaranteed under any bus capacitance value or pull-up resistor configuration on the RxD pin.

RS-485 DATA RATE AND BUS CAPACITANCE

The data rate and bus node capability of the ADM3095E are dependent on the operating temperature of the device. As the operating temperature of the ADM3095E increases, the capacitance of the ADM3095E integrated EMC protection circuitry also increases.

The driver output structures of the ADM3095E can be simplified as low-pass filter structures, with a given resistance and capacitance. As the operating temperature increases, the capacitance increases; therefore the low-pass filter effectively works to decrease the maximum data rate that can be driven on the RS-485 bus pins.

HOT SWAP CAPABILITY

When a circuit board is inserted into a hot (or powered) backplane, differential disturbances to the data bus can lead to data errors. The ADM3095E was lab tested to ensure that the RS-485 A and B bus pins do not output spurious data during a V_{CC} power-up or power-down event, which simulates a PCB hot insertion. The V_{CC} ramp test rates are 0 V to 5 V in 300 μ s (fast ramp rate), and 0 V to 5 V in 9.5 ms (slow ramp rate). For these ramp rates, the RS-485 A and B outputs were monitored and no output glitches were observed.

APPLICATIONS INFORMATION

ROBUST HALF DUPLEX RS-485 NETWORK

Figure 41 shows a robust RS-485 communications network, with bus communications running over 1000 feet of cabling. Over long cable runs with multiple RS-485 nodes, a number of hazards can either corrupt data communication or even cause permanent damage to the RS-485 interface.

The [ADM3095E](#) provides robust protection against high voltage faults to bus power supplies and EMC transients, such as an IEC 61000-4-5 surge. In addition, the [ADM3095E](#) has an extended common-mode input range of ± 25 V, which allows ± 25 V of ground potential difference between the GND pins of two or more [ADM3095E](#) devices.

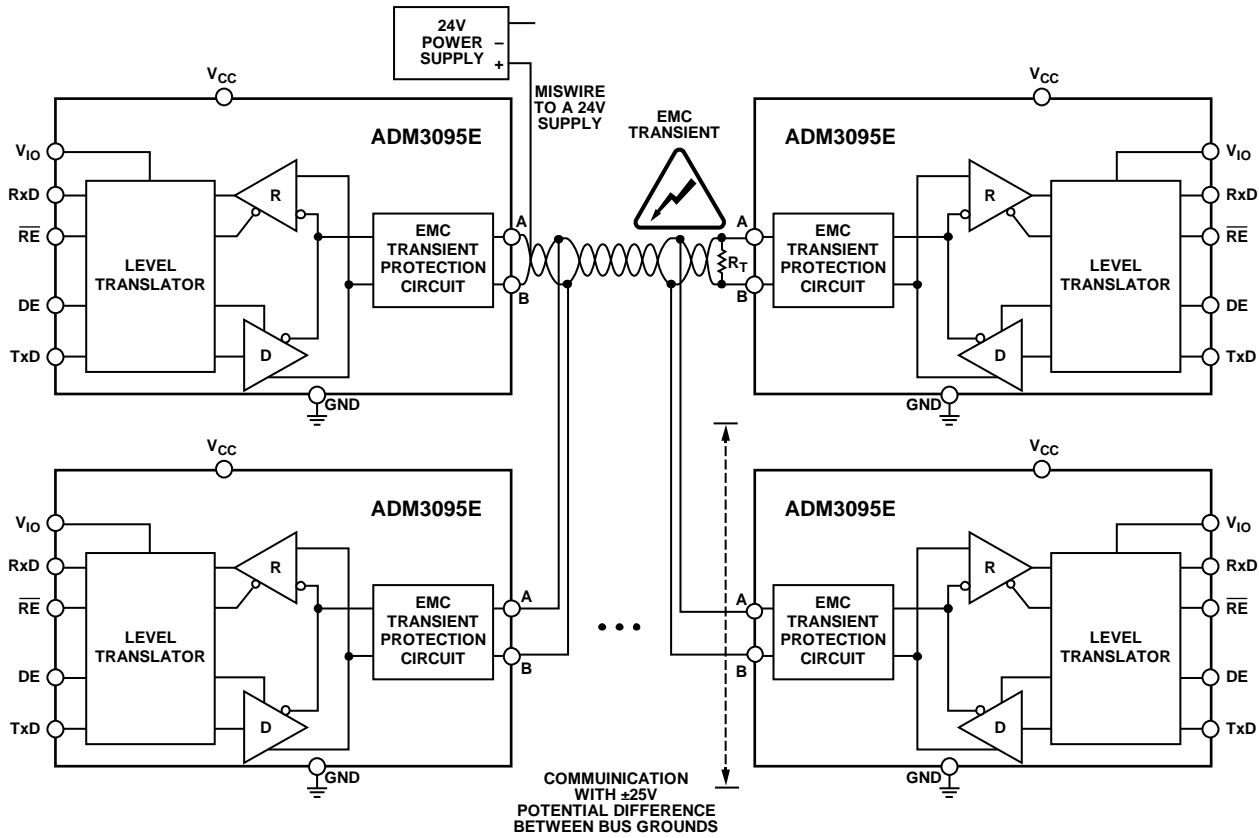
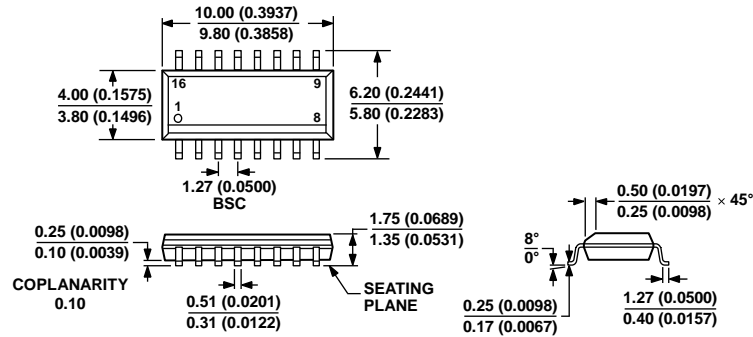

Figure 41. RS-485 Communications Network

14685-040

OUTLINE DIMENSIONS



COMPLIANT TO JEDEC STANDARDS MS-012-AC
 CONTROLLING DIMENSIONS ARE IN MILLIMETERS; INCH DIMENSIONS
 (IN PARENTHESES) ARE ROUNDED-OFF MILLIMETER EQUIVALENTS FOR
 REFERENCE ONLY AND ARE NOT APPROPRIATE FOR USE IN DESIGN.

Figure 42. 16-Lead Standard Small Outline Package [SOIC_N]
 Narrow Body
 (R-16)

Dimensions shown in millimeters and (inches)

060606-A

ORDERING GUIDE

Model ¹	Temperature Range	Package Description	Package Option
ADM3095EBRZ	-40°C to +125°C	16-Lead Standard Small Outline Package [SOIC_N]	R-16
ADM3095EBRZ-RL7	-40°C to +125°C	16-Lead Standard Small Outline Package [SOIC_N]	R-16
ADM3095EARZ	-40°C to +85°C	16-Lead Standard Small Outline Package [SOIC_N]	R-16
ADM3095EARZ-RL7	-40°C to +85°C	16-Lead Standard Small Outline Package [SOIC_N]	R-16
EVAL-ADM3095EEBZ		ADM3095E Evaluation Board	

¹ Z = RoHS Compliant Part.

Looking for pricing, stock, or lifecycle information?

Click below to explore more details on WIN SOURCE:

 [View ADM3095EBRZ on WIN SOURCE](#)

 [Analog Devices Inc. Information](#)

Optimize Your Supply Chain with WIN SOURCE Solutions

-  Global Sourcing Solution
-  Obsolete Management
-  Cost Control Management
-  Shortage Management
-  Alternative Solution
-  Excess Inventory Management