



**THE DATASHEET OF
XE167F96F66LACFXUMA1**



XE167

16-Bit Single-Chip
Real Time Signal Controller

16bit

Microcontrollers



Never stop thinking

Edition 2008-08

**Published by
Infineon Technologies AG
81726 Munich, Germany**

**© 2008 Infineon Technologies AG
All Rights Reserved.**

Legal Disclaimer

The information given in this document shall in no event be regarded as a guarantee of conditions or characteristics. With respect to any examples or hints given herein, any typical values stated herein and/or any information regarding the application of the device, Infineon Technologies hereby disclaims any and all warranties and liabilities of any kind, including without limitation, warranties of non-infringement of intellectual property rights of any third party.

Information

For further information on technology, delivery terms and conditions and prices, please contact the nearest Infineon Technologies Office (www.infineon.com).

Warnings

Due to technical requirements, components may contain dangerous substances. For information on the types in question, please contact the nearest Infineon Technologies Office.

Infineon Technologies components may be used in life-support devices or systems only with the express written approval of Infineon Technologies, if a failure of such components can reasonably be expected to cause the failure of that life-support device or system or to affect the safety or effectiveness of that device or system. Life support devices or systems are intended to be implanted in the human body or to support and/or maintain and sustain and/or protect human life. If they fail, it is reasonable to assume that the health of the user or other persons may be endangered.

XE167

16-Bit Single-Chip
Real Time Signal Controller

Microcontrollers



Never stop thinking

XE167

Revision History: V2.1, 2008-08

Previous Version(s):
V2.0, 2008-03, Preliminary
V0.1, 2007-09, Preliminary

Page	Subjects (major changes since last revision)
several	Maximum frequency changed to 80 MHz
33	Voltage domain for XTAL1/XTAL2 corrected to M
73	Coupling factors corrected
78, 80	Improved leakage parameters
79, 81	Pin leakage formula corrected
86	Improved ADC error values
99f	Improved definition of external clock parameters
115	JTAG clock speed corrected

We Listen to Your Comments

Any information within this document that you feel is wrong, unclear or missing at all? Your feedback will help us to continuously improve the quality of this document.

Please send your proposal (including a reference to this document) to:

mcdocu.comments@infineon.com



1	Summary of Features	4
2	General Device Information	8
2.1	Pin Configuration and Definition	9
3	Functional Description	36
3.1	Memory Subsystem and Organization	37
3.2	External Bus Controller	40
3.3	Central Processing Unit (CPU)	41
3.4	Interrupt System	43
3.5	On-Chip Debug Support (OCDS)	49
3.6	Capture/Compare Unit (CAPCOM2)	50
3.7	Capture/Compare Units CCU6x	53
3.8	General Purpose Timer (GPT12E) Unit	55
3.9	Real Time Clock	59
3.10	A/D Converters	61
3.11	Universal Serial Interface Channel Modules (USIC)	62
3.12	MultiCAN Module	64
3.13	Watchdog Timer	66
3.14	Clock Generation	66
3.15	Parallel Ports	67
3.16	Instruction Set Summary	69
4	Electrical Parameters	72
4.1	General Parameters	72
4.2	DC Parameters	76
4.2.1	DC Parameters for Upper Voltage Area	78
4.2.2	DC Parameters for Lower Voltage Area	80
4.2.3	Power Consumption	82
4.3	Analog/Digital Converter Parameters	86
4.4	System Parameters	89
4.5	Flash Memory Parameters	91
4.6	AC Parameters	93
4.6.1	Testing Waveforms	93
4.6.2	Definition of Internal Timing	94
4.6.3	External Clock Input Parameters	99
4.6.4	External Bus Timing	101
4.6.5	Synchronous Serial Interface Timing	112
4.6.6	JTAG Interface Timing	115
5	Package and Reliability	117
5.1	Packaging	117
5.2	Thermal Considerations	119



**16-Bit Single-Chip
Real Time Signal Controller
XE166 Family**

XE167

1 Summary of Features

For a quick overview and easy reference, the features of the XE167 are summarized here.

- High-performance CPU with five-stage pipeline
 - 12.5 ns instruction cycle at 80 MHz CPU clock (single-cycle execution)
 - One-cycle 32-bit addition and subtraction with 40-bit result
 - One-cycle multiplication (16 × 16 bit)
 - Background division (32 / 16 bit) in 21 cycles
 - One-cycle multiply-and-accumulate (MAC) instructions
 - Enhanced Boolean bit manipulation facilities
 - Zero-cycle jump execution
 - Additional instructions to support HLL and operating systems
 - Register-based design with multiple variable register banks
 - Fast context switching support with two additional local register banks
 - 16 Mbytes total linear address space for code and data
 - 1024 Bytes on-chip special function register area (C166 Family compatible)
- Interrupt system with 16 priority levels for up to 87 sources
 - Selectable external inputs for interrupt generation and wake-up
 - Fastest sample-rate 12.5 ns
- Eight-channel interrupt-driven single-cycle data transfer with Peripheral Event Controller (PEC), 24-bit pointers cover total address space
- Clock generation from internal or external clock sources, using on-chip PLL or prescaler
- On-chip memory modules
 - 1 Kbyte on-chip stand-by RAM (SBRAM)
 - 2 Kbytes on-chip dual-port RAM (DPRAM)
 - 16 Kbytes on-chip data SRAM (DSRAM)
 - Up to 64 Kbytes on-chip program/data SRAM (PSRAM)
 - Up to 768 Kbytes on-chip program memory (Flash memory)
- On-Chip Peripheral Modules
 - Two Synchronizable A/D Converters with up to 24 channels, 10-bit resolution, conversion time below 1 μs, optional data preprocessing (data reduction, range check)
 - 16-channel general purpose capture/compare unit (CAPCOM2)
 - Up to four capture/compare units for flexible PWM signal generation (CCU6x)
 - Multi-functional general purpose timer unit with 5 timers

Summary of Features

- Up to 6 serial interface channels to be used as UART, LIN, high-speed synchronous channel (SPI/QSPI), IIC bus interface (10-bit addressing, 400 kbit/s), IIS interface
- On-chip MultiCAN interface (Rev. 2.0B active) with up to 128 message objects (Full CAN/Basic CAN) on up to 5 CAN nodes and gateway functionality
- On-chip real time clock
- Up to 12 Mbytes external address space for code and data
 - Programmable external bus characteristics for different address ranges
 - Multiplexed or demultiplexed external address/data buses
 - Selectable address bus width
 - 16-bit or 8-bit data bus width
 - Five programmable chip-select signals
 - Hold- and hold-acknowledge bus arbitration support
- Single power supply from 3.0 V to 5.5 V
- Programmable watchdog timer and oscillator watchdog
- Up to 118 general purpose I/O lines
- On-chip bootstrap loaders
- Supported by a full range of development tools including C compilers, macro-assembler packages, emulators, evaluation boards, HLL debuggers, simulators, logic analyzer disassemblers, programming boards
- On-chip debug support via JTAG interface
- 144-pin Green LQFP package, 0.5 mm (19.7 mil) pitch

Ordering Information

The ordering code for an Infineon microcontroller provides an exact reference to a specific product. This ordering code identifies:

- the derivative itself, i.e. its function set, the temperature range, and the supply voltage
- the package and the type of delivery.

For ordering codes for the XE167 please contact your sales representative or local distributor.

This document describes several derivatives of the XE167 group. **Table 1** lists these derivatives and summarizes the differences. As this document refers to all of these derivatives, some descriptions may not apply to a specific product.

For simplicity the term **XE167** is used for all derivatives throughout this document.

Summary of Features

Table 1 XE167 Derivative Synopsis

Derivative ¹⁾	Temp. Range	Program Memory ²⁾	PSRAM ³⁾	CCU6 Mod.	ADC ⁴⁾ Chan.	Interfaces ⁴⁾
SAF-XE167F-48F66L	-40 °C to 85 °C	384 Kbytes Flash	16 Kbytes	0, 1, 2, 3	16 + 8	5 CAN Nodes, 6 Serial Chan.
SAF-XE167F-72F66L	-40 °C to 85 °C	576 Kbytes Flash	32 Kbytes	0, 1, 2, 3	16 + 8	5 CAN Nodes, 6 Serial Chan.
SAF-XE167F-96FxxL	-40 °C to 85 °C	768 Kbytes Flash	64 Kbytes	0, 1, 2, 3	16 + 8	5 CAN Nodes, 6 Serial Chan.
SAF-XE167G-48F66L	-40 °C to 85 °C	384 Kbytes Flash	16 Kbytes	0, 1	8 + 8	2 CAN Nodes, 4 Serial Chan.
SAF-XE167G-72F66L	-40 °C to 85 °C	576 Kbytes Flash	32 Kbytes	0, 1	8 + 8	2 CAN Nodes, 4 Serial Chan.
SAF-XE167G-96F66L	-40 °C to 85 °C	768 Kbytes Flash	64 Kbytes	0, 1	8 + 8	2 CAN Nodes, 4 Serial Chan.
SAF-XE167H-48F66L	-40 °C to 85 °C	384 Kbytes Flash	16 Kbytes	0, 1, 2, 3	16 + 8	No CAN Node, 6 Serial Chan.
SAF-XE167H-72F66L	-40 °C to 85 °C	576 Kbytes Flash	32 Kbytes	0, 1, 2, 3	16 + 8	No CAN Node, 6 Serial Chan.
SAF-XE167H-96F66L	-40 °C to 85 °C	768 Kbytes Flash	64 Kbytes	0, 1, 2, 3	16 + 8	No CAN Node, 6 Serial Chan.
SAF-XE167K-48F66L	-40 °C to 85 °C	384 Kbytes Flash	16 Kbytes	0, 1	8 + 8	No CAN Node, 4 Serial Chan.
SAF-XE167K-72F66L	-40 °C to 85 °C	576 Kbytes Flash	32 Kbytes	0, 1	8 + 8	No CAN Node, 4 Serial Chan.
SAF-XE167K-96F66L	-40 °C to 85 °C	768 Kbytes Flash	64 Kbytes	0, 1	8 + 8	No CAN Node, 4 Serial Chan.

1) This Data Sheet is valid for devices starting with and including design step AC.

2) Specific information about the on-chip Flash memory in [Table 2](#).

3) All derivatives additionally provide 1 Kbyte SBRAM, 2 Kbytes DPRAM, and 16 Kbytes DSRAM.

4) Specific information about the available channels in [Table 3](#).

 Analog input channels are listed for each Analog/Digital Converter module separately (ADC0 + ADC1).

Summary of Features

The XE167 types are offered with several Flash memory sizes. [Table 2](#) describes the location of the available memory areas for each Flash memory size.

Table 2 Flash Memory Allocation

Total Flash Size	Flash Area A ¹⁾	Flash Area B	Flash Area C
768 Kbytes	C0'0000 _H ... C0'FFFF _H	C1'0000 _H ... CB'FFFF _H	n.a.
576 Kbytes	C0'0000 _H ... C0'FFFF _H	C1'0000 _H ... C8'FFFF _H	n.a.
384 Kbytes	C0'0000 _H ... C0'FFFF _H	C1'0000 _H ... C5'FFFF _H	n.a.

1) The uppermost 4-Kbyte sector of the first Flash segment is reserved for internal use (C0'F000_H to C0'FFFF_H).

The XE167 types are offered with different interface options. [Table 3](#) lists the available channels for each option.

Table 3 Interface Channel Association

Total Number	Available Channels
16 ADC0 channels	CH0 ... CH15
8 ADC0 channels	CH0 ... CH7
8 ADC1 channels	CH0 ... CH7
5 CAN nodes	CAN0, CAN1, CAN2, CAN3, CAN4
2 CAN nodes	CAN0, CAN1
6 serial channels	U0C0, U0C1, U1C0, U1C1, U2C0, U2C1
4 serial channels	U0C0, U0C1, U1C0, U1C1

2 General Device Information

The XE167 series of real time signal controllers is a part of the Infineon XE166 Family of full-feature single-chip CMOS microcontrollers. These devices extend the functionality and performance of the C166 Family in terms of instructions (MAC unit), peripherals, and speed. They combine high CPU performance (up to 80 million instructions per second) with extended peripheral functionality and enhanced IO capabilities. Optimized peripherals can be adapted flexibly to meet the application requirements. These derivatives utilize clock generation via PLL and internal or external clock sources. On-chip memory modules include program Flash, program RAM, and data RAM.

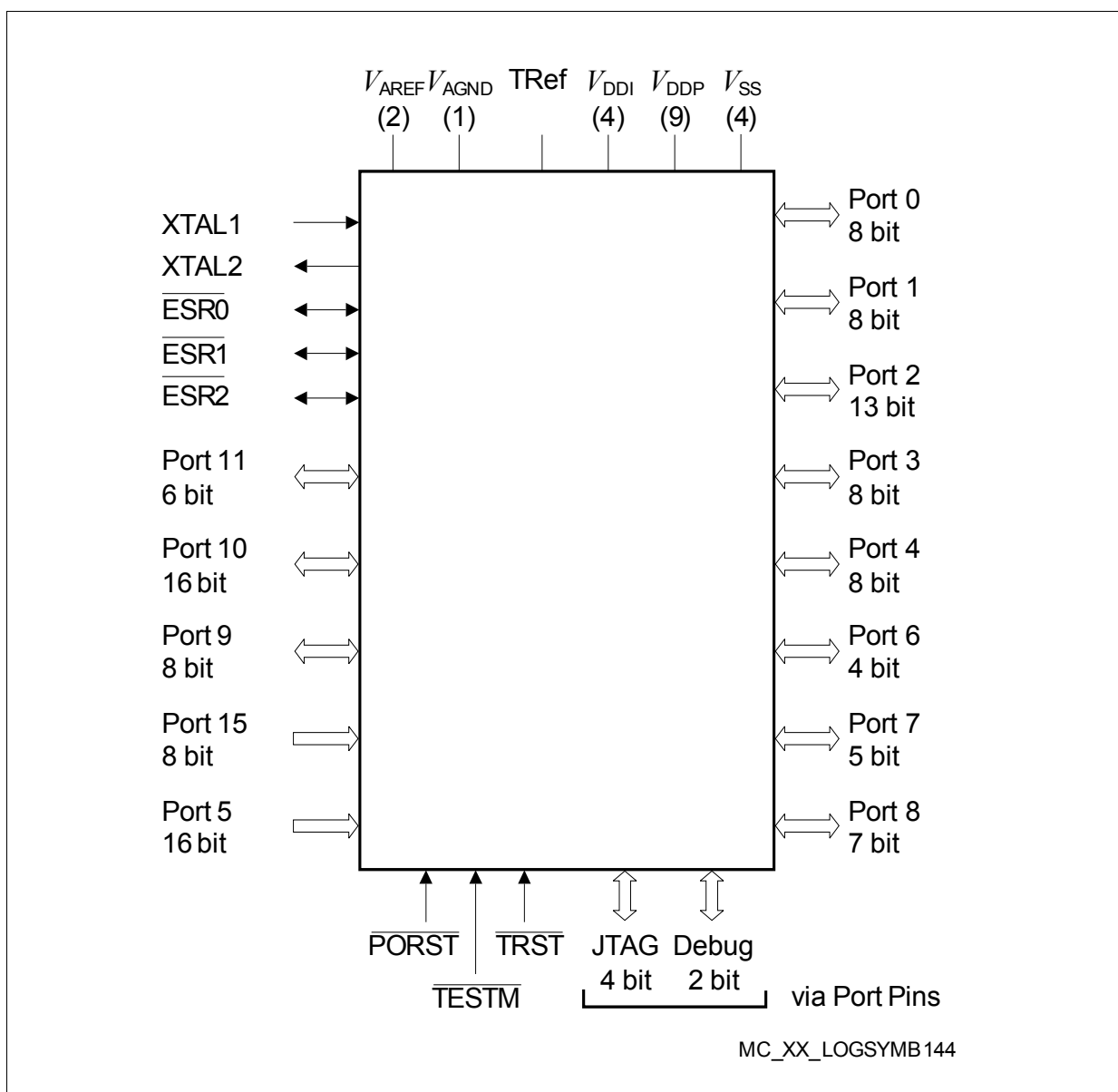

Figure 1 Logic Symbol

2.1 Pin Configuration and Definition

The pins of the XE167 are described in detail in [Table 4](#), which includes all alternate functions. For further explanations please refer to the footnotes at the end of the table. [Figure 2](#) summarizes all pins, showing their locations on the four sides of the package.

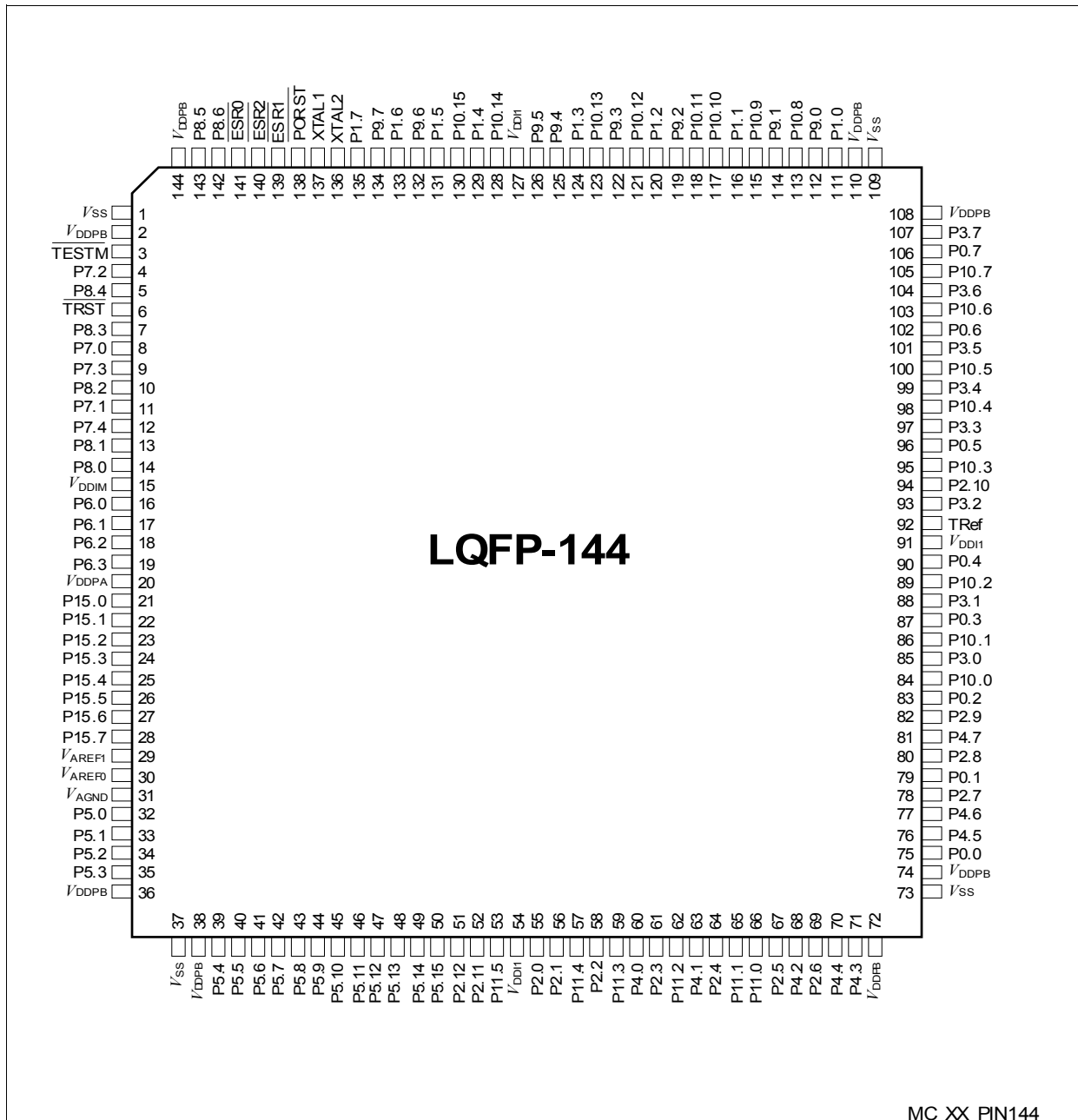

Figure 2 Pin Configuration (top view)

Notes to Pin Definitions

1. **Ctrl.:** The output signal for a port pin is selected by bitfield PC in the associated register Px_IOCry. Output O0 is selected by setting the respective bitfield PC to 1x00_B, output O1 is selected by 1x01_B, etc.
Output signal OH is controlled by hardware.
2. **Type:** Indicates the pad type used (St=standard pad, Sp=special pad, DP=double pad, In=input pad, PS=power supply) and its power supply domain (A, B, M, 1).

Table 4 Pin Definitions and Functions

Pin	Symbol	Ctrl.	Type	Function
3	$\overline{\text{TESTM}}$	I	In/B	Testmode Enable Enables factory test modes, must be held HIGH for normal operation (connect to V_{DDPB}). An internal pullup device will hold this pin high when nothing is driving it.
4	P7.2	O0 / I	St/B	Bit 2 of Port 7, General Purpose Input/Output
	EMUX0	O1	St/B	External Analog MUX Control Output 0 (ADC1)
	TxDC4	O2	St/B	CAN Node 4 Transmit Data Output
	CCU62_ CCPOS0A	I	St/B	CCU62 Position Input 0
	TDI_C	I	St/B	JTAG Test Data Input
5	P8.4	O0 / I	St/B	Bit 4 of Port 8, General Purpose Input/Output
	CCU60_ COUT61	O1	St/B	CCU60 Channel 1 Output
	TMS_D	I	St/B	JTAG Test Mode Selection Input
6	$\overline{\text{TRST}}$	I	In/B	Test-System Reset Input For normal system operation, pin $\overline{\text{TRST}}$ should be held low. A high level at this pin at the rising edge of $\overline{\text{PORST}}$ activates the XE167's debug system. In this case, pin $\overline{\text{TRST}}$ must be driven low once to reset the debug system. An internal pulldown device will hold this pin low when nothing is driving it.
7	P8.3	O0 / I	St/B	Bit 3 of Port 8, General Purpose Input/Output
	CCU60_ COUT60	O1	St/B	CCU60 Channel 0 Output
	TDI_D	I	St/B	JTAG Test Data Input

Table 4 Pin Definitions and Functions (cont'd)

Pin	Symbol	Ctrl.	Type	Function
8	P7.0	O0 / I	St/B	Bit 0 of Port 7, General Purpose Input/Output
	T3OUT	O1	St/B	GPT1 Timer T3 Toggle Latch Output
	T6OUT	O2	St/B	GPT2 Timer T6 Toggle Latch Output
	TDO_A	OH	St/B	JTAG Test Data Output
	ESR2_1	I	St/B	ESR2 Trigger Input 1
	RxDC4B	I	St/B	CAN Node 4 Receive Data Input
9	P7.3	O0 / I	St/B	Bit 3 of Port 7, General Purpose Input/Output
	EMUX1	O1	St/B	External Analog MUX Control Output 1 (ADC1)
	U0C1_DOUT	O2	St/B	USIC0 Channel 1 Shift Data Output
	U0C0_DOUT	O3	St/B	USIC0 Channel 0 Shift Data Output
	CCU62_ CCPOS1A	I	St/B	CCU62 Position Input 1
	TMS_C	I	St/B	JTAG Test Mode Selection Input
	U0C1_DX0F	I	St/B	USIC0 Channel 1 Shift Data Input
10	P8.2	O0 / I	St/B	Bit 2 of Port 8, General Purpose Input/Output
	CCU60_ CC62	O1 / I	St/B	CCU60 Channel 2 Input/Output
11	P7.1	O0 / I	St/B	Bit 1 of Port 7, General Purpose Input/Output
	EXTCLK	O1	St/B	Programmable Clock Signal Output
	TxDC4	O2	St/B	CAN Node 4 Transmit Data Output
	CCU62_ CTRAPA	I	St/B	CCU62 Emergency Trap Input
	$\overline{\text{BRKIN_C}}$	I	St/B	OCDS Break Signal Input

Table 4 Pin Definitions and Functions (cont'd)

Pin	Symbol	Ctrl.	Type	Function
12	P7.4	O0 / I	St/B	Bit 4 of Port 7, General Purpose Input/Output
	EMUX2	O1	St/B	External Analog MUX Control Output 2 (ADC1)
	U0C1_DOUT	O2	St/B	USIC0 Channel 1 Shift Data Output
	U0C1_SCLKOUT	O3	St/B	USIC0 Channel 1 Shift Clock Output
	CCU62_CCPOS2A	I	St/B	CCU62 Position Input 2
	TCK_C	I	St/B	JTAG Clock Input
	U0C0_DX0D	I	St/B	USIC0 Channel 0 Shift Data Input
	U0C1_DX1E	I	St/B	USIC0 Channel 1 Shift Clock Input
13	P8.1	O0 / I	St/B	Bit 1 of Port 8, General Purpose Input/Output
	CCU60_CC61	O1 / I	St/B	CCU60 Channel 1 Input/Output
14	P8.0	O0 / I	St/B	Bit 0 of Port 8, General Purpose Input/Output
	CCU60_CC60	O1 / I	St/B	CCU60 Channel 0 Input/Output
16	P6.0	O0 / I	St/A	Bit 0 of Port 6, General Purpose Input/Output
	EMUX0	O1	St/A	External Analog MUX Control Output 0 (ADC0)
	$\overline{\text{BRKOUT}}$	O3	St/A	OCDS Break Signal Output
	ADCx_REQGTyC	I	St/A	External Request Gate Input for ADC0/1
	U1C1_DX0E	I	St/A	USIC1 Channel 1 Shift Data Input
17	P6.1	O0 / I	St/A	Bit 1 of Port 6, General Purpose Input/Output
	EMUX1	O1	St/A	External Analog MUX Control Output 1 (ADC0)
	T3OUT	O2	St/A	GPT1 Timer T3 Toggle Latch Output
	U1C1_DOUT	O3	St/A	USIC1 Channel 1 Shift Data Output
	ADCx_REQTRYC	I	St/A	External Request Trigger Input for ADC0/1

Table 4 Pin Definitions and Functions (cont'd)

Pin	Symbol	Ctrl.	Type	Function
18	P6.2	O0 / I	St/A	Bit 2 of Port 6, General Purpose Input/Output
	EMUX2	O1	St/A	External Analog MUX Control Output 2 (ADC0)
	T6OUT	O2	St/A	GPT2 Timer T6 Toggle Latch Output
	U1C1_SCLKOUT	O3	St/A	USIC1 Channel 1 Shift Clock Output
	U1C1_DX1C	I	St/A	USIC1 Channel 1 Shift Clock Input
19	P6.3	O0 / I	St/A	Bit 3 of Port 6, General Purpose Input/Output
	T3OUT	O2	St/A	GPT1 Timer T3 Toggle Latch Output
	U1C1_SELO0	O3	St/A	USIC1 Channel 1 Select/Control 0 Output
	U1C1_DX2D	I	St/A	USIC1 Channel 1 Shift Control Input
	ADCx_REQTRYD	I	St/A	External Request Trigger Input for ADC0/1
21	P15.0	I	In/A	Bit 0 of Port 15, General Purpose Input
	ADC1_CH0	I	In/A	Analog Input Channel 0 for ADC1
22	P15.1	I	In/A	Bit 1 of Port 15, General Purpose Input
	ADC1_CH1	I	In/A	Analog Input Channel 1 for ADC1
23	P15.2	I	In/A	Bit 2 of Port 15, General Purpose Input
	ADC1_CH2	I	In/A	Analog Input Channel 2 for ADC1
	T5IN	I	In/A	GPT2 Timer T5 Count/Gate Input
24	P15.3	I	In/A	Bit 3 of Port 15, General Purpose Input
	ADC1_CH3	I	In/A	Analog Input Channel 3 for ADC1
	T5EUD	I	In/A	GPT2 Timer T5 External Up/Down Control Input
25	P15.4	I	In/A	Bit 4 of Port 15, General Purpose Input
	ADC1_CH4	I	In/A	Analog Input Channel 4 for ADC1
	T6IN	I	In/A	GPT2 Timer T6 Count/Gate Input
26	P15.5	I	In/A	Bit 5 of Port 15, General Purpose Input
	ADC1_CH5	I	In/A	Analog Input Channel 5 for ADC1
	T6EUD	I	In/A	GPT2 Timer T6 External Up/Down Control Input
27	P15.6	I	In/A	Bit 6 of Port 15, General Purpose Input
	ADC1_CH6	I	In/A	Analog Input Channel 6 for ADC1

Table 4 Pin Definitions and Functions (cont'd)

Pin	Symbol	Ctrl.	Type	Function
28	P15.7	I	In/A	Bit 7 of Port 15, General Purpose Input
	ADC1_CH7	I	In/A	Analog Input Channel 7 for ADC1
29	V_{AREF1}	-	PS/A	Reference Voltage for A/D Converter ADC1
30	V_{AREF0}	-	PS/A	Reference Voltage for A/D Converter ADC0
31	V_{AGND}	-	PS/A	Reference Ground for A/D Converters ADC0/1
32	P5.0	I	In/A	Bit 0 of Port 5, General Purpose Input
	ADC0_CH0	I	In/A	Analog Input Channel 0 for ADC0
33	P5.1	I	In/A	Bit 1 of Port 5, General Purpose Input
	ADC0_CH1	I	In/A	Analog Input Channel 1 for ADC0
34	P5.2	I	In/A	Bit 2 of Port 5, General Purpose Input
	ADC0_CH2	I	In/A	Analog Input Channel 2 for ADC0
	TDI_A	I	In/A	JTAG Test Data Input
35	P5.3	I	In/A	Bit 3 of Port 5, General Purpose Input
	ADC0_CH3	I	In/A	Analog Input Channel 3 for ADC0
	T3IN	I	In/A	GPT1 Timer T3 Count/Gate Input
39	P5.4	I	In/A	Bit 4 of Port 5, General Purpose Input
	ADC0_CH4	I	In/A	Analog Input Channel 4 for ADC0
	CCU63_T12HRB	I	In/A	External Run Control Input for T12 of CCU63
	T3EUD	I	In/A	GPT1 Timer T3 External Up/Down Control Input
	TMS_A	I	In/A	JTAG Test Mode Selection Input
40	P5.5	I	In/A	Bit 5 of Port 5, General Purpose Input
	ADC0_CH5	I	In/A	Analog Input Channel 5 for ADC0
	CCU60_T12HRB	I	In/A	External Run Control Input for T12 of CCU60
41	P5.6	I	In/A	Bit 6 of Port 5, General Purpose Input
	ADC0_CH6	I	In/A	Analog Input Channel 6 for ADC0
42	P5.7	I	In/A	Bit 7 of Port 5, General Purpose Input
	ADC0_CH7	I	In/A	Analog Input Channel 7 for ADC0

Table 4 Pin Definitions and Functions (cont'd)

Pin	Symbol	Ctrl.	Type	Function
43	P5.8	I	In/A	Bit 8 of Port 5, General Purpose Input
	ADC0_CH8	I	In/A	Analog Input Channel 8 for ADC0
	CCU6x_T12HRC	I	In/A	External Run Control Input for T12 of CCU6x
	CCU6x_T13HRC	I	In/A	External Run Control Input for T13 of CCU6x
44	P5.9	I	In/A	Bit 9 of Port 5, General Purpose Input
	ADC0_CH9	I	In/A	Analog Input Channel 9 for ADC0
	CC2_T7IN	I	In/A	CAPCOM2 Timer T7 Count Input
45	P5.10	I	In/A	Bit 10 of Port 5, General Purpose Input
	ADC0_CH10	I	In/A	Analog Input Channel 10 for ADC0
	BRKIN_A	I	In/A	OCDS Break Signal Input
46	P5.11	I	In/A	Bit 11 of Port 5, General Purpose Input
	ADC0_CH11	I	In/A	Analog Input Channel 11 for ADC0
47	P5.12	I	In/A	Bit 12 of Port 5, General Purpose Input
	ADC0_CH12	I	In/A	Analog Input Channel 12 for ADC0
48	P5.13	I	In/A	Bit 13 of Port 5, General Purpose Input
	ADC0_CH13	I	In/A	Analog Input Channel 13 for ADC0
	EX0BINB	I	In/A	External Interrupt Trigger Input
49	P5.14	I	In/A	Bit 14 of Port 5, General Purpose Input
	ADC0_CH14	I	In/A	Analog Input Channel 14 for ADC0
50	P5.15	I	In/A	Bit 15 of Port 5, General Purpose Input
	ADC0_CH15	I	In/A	Analog Input Channel 15 for ADC0
51	P2.12	O0 / I	St/B	Bit 12 of Port 2, General Purpose Input/Output
	U0C0_SELO4	O1	St/B	USIC0 Channel 0 Select/Control 4 Output
	U0C1_SELO3	O2	St/B	USIC0 Channel 1 Select/Control 3 Output
	READY	I	St/B	External Bus Interface READY Input

Table 4 Pin Definitions and Functions (cont'd)

Pin	Symbol	Ctrl.	Type	Function
52	P2.11	O0 / I	St/B	Bit 11 of Port 2, General Purpose Input/Output
	U0C0_SELO2	O1	St/B	USIC0 Channel 0 Select/Control 2 Output
	U0C1_SELO2	O2	St/B	USIC0 Channel 1 Select/Control 2 Output
	$\overline{\text{BHE}}/\overline{\text{WRH}}$	OH	St/B	External Bus Interf. High-Byte Control Output Can operate either as Byte High Enable ($\overline{\text{BHE}}$) or as Write strobe for High Byte ($\overline{\text{WRH}}$).
53	P11.5	O0 / I	St/B	Bit 5 of Port 11, General Purpose Input/Output
55	P2.0	O0 / I	St/B	Bit 0 of Port 2, General Purpose Input/Output
	CCU63_CC60	O2 / I	St/B	CCU63 Channel 0 Input/Output
	AD13	OH / I	St/B	External Bus Interface Address/Data Line 13
	RxDC0C	I	St/B	CAN Node 0 Receive Data Input
56	P2.1	O0 / I	St/B	Bit 1 of Port 2, General Purpose Input/Output
	TxDC0	O1	St/B	CAN Node 0 Transmit Data Output
	CCU63_CC61	O2 / I	St/B	CCU63 Channel 1 Input/Output
	AD14	OH / I	St/B	External Bus Interface Address/Data Line 14
	ESR1_5	I	St/B	ESR1 Trigger Input 5
	EX0AINA	I	St/B	External Interrupt Trigger Input
57	P11.4	O0 / I	St/B	Bit 4 of Port 11, General Purpose Input/Output
58	P2.2	O0 / I	St/B	Bit 2 of Port 2, General Purpose Input/Output
	TxDC1	O1	St/B	CAN Node 1 Transmit Data Output
	CCU63_CC62	O2 / I	St/B	CCU63 Channel 2 Input/Output
	AD15	OH / I	St/B	External Bus Interface Address/Data Line 15
	ESR2_5	I	St/B	ESR2 Trigger Input 5
	EX1AINA	I	St/B	External Interrupt Trigger Input
59	P11.3	O0 / I	St/B	Bit 3 of Port 11, General Purpose Input/Output

Table 4 Pin Definitions and Functions (cont'd)

Pin	Symbol	Ctrl.	Type	Function
60	P4.0	O0 / I	St/B	Bit 0 of Port 4, General Purpose Input/Output
	CC2_24	O3 / I	St/B	CAPCOM2 CC24IO Capture Inp./ Compare Out.
	CS0	OH	St/B	External Bus Interface Chip Select 0 Output
61	P2.3	O0 / I	St/B	Bit 3 of Port 2, General Purpose Input/Output
	U0C0_DOUT	O1	St/B	USIC0 Channel 0 Shift Data Output
	CCU63_COUT63	O2	St/B	CCU63 Channel 3 Output
	CC2_16	O3 / I	St/B	CAPCOM2 CC16IO Capture Inp./ Compare Out.
	A16	OH	St/B	External Bus Interface Address Line 16
	ESR2_0	I	St/B	ESR2 Trigger Input 0
	U0C0_DX0E	I	St/B	USIC0 Channel 0 Shift Data Input
	U0C1_DX0D	I	St/B	USIC0 Channel 1 Shift Data Input
	RxDC0A	I	St/B	CAN Node 0 Receive Data Input
62	P11.2	O0 / I	St/B	Bit 2 of Port 11, General Purpose Input/Output
	CCU63_CCPOS2A	I	St/B	CCU63 Position Input 2
63	P4.1	O0 / I	St/B	Bit 1 of Port 4, General Purpose Input/Output
	TxDC2	O2	St/B	CAN Node 2 Transmit Data Output
	CC2_25	O3 / I	St/B	CAPCOM2 CC25IO Capture Inp./ Compare Out.
	CS1	OH	St/B	External Bus Interface Chip Select 1 Output
64	P2.4	O0 / I	St/B	Bit 4 of Port 2, General Purpose Input/Output
	U0C1_DOUT	O1	St/B	USIC0 Channel 1 Shift Data Output
	TxDC0	O2	St/B	CAN Node 0 Transmit Data Output
	CC2_17	O3 / I	St/B	CAPCOM2 CC17IO Capture Inp./ Compare Out.
	A17	OH	St/B	External Bus Interface Address Line 17
	ESR1_0	I	St/B	ESR1 Trigger Input 0
	U0C0_DX0F	I	St/B	USIC0 Channel 0 Shift Data Input
RxDC1A	I	St/B	CAN Node 1 Receive Data Input	
65	P11.1	O0 / I	St/B	Bit 1 of Port 11, General Purpose Input/Output
	CCU63_CCPOS1A	I	St/B	CCU63 Position Input 1

Table 4 Pin Definitions and Functions (cont'd)

Pin	Symbol	Ctrl.	Type	Function
66	P11.0	O0 / I	St/B	Bit 0 of Port 11, General Purpose Input/Output
	CCU63_ CCPOS0A	I	St/B	CCU63 Position Input 0
67	P2.5	O0 / I	St/B	Bit 5 of Port 2, General Purpose Input/Output
	U0C0_ SCLKOUT	O1	St/B	USIC0 Channel 0 Shift Clock Output
	TxDC0	O2	St/B	CAN Node 0 Transmit Data Output
	CC2_18	O3 / I	St/B	CAPCOM2 CC18IO Capture Inp./ Compare Out.
	A18	OH	St/B	External Bus Interface Address Line 18
	U0C0_DX1D	I	St/B	USIC0 Channel 0 Shift Clock Input
68	P4.2	O0 / I	St/B	Bit 2 of Port 4, General Purpose Input/Output
	TxDC2	O2	St/B	CAN Node 2 Transmit Data Output
	CC2_26	O3 / I	St/B	CAPCOM2 CC26IO Capture Inp./ Compare Out.
	CS2	OH	St/B	External Bus Interface Chip Select 2 Output
	T2IN	I	St/B	GPT1 Timer T2 Count/Gate Input
69	P2.6	O0 / I	St/B	Bit 6 of Port 2, General Purpose Input/Output
	U0C0_ SELO0	O1	St/B	USIC0 Channel 0 Select/Control 0 Output
	U0C1_ SELO1	O2	St/B	USIC0 Channel 1 Select/Control 1 Output
	CC2_19	O3 / I	St/B	CAPCOM2 CC19IO Capture Inp./ Compare Out.
	A19	OH	St/B	External Bus Interface Address Line 19
	U0C0_DX2D	I	St/B	USIC0 Channel 0 Shift Control Input
	RxDC0D	I	St/B	CAN Node 0 Receive Data Input
70	P4.4	O0 / I	St/B	Bit 4 of Port 4, General Purpose Input/Output
	CC2_28	O3 / I	St/B	CAPCOM2 CC28IO Capture Inp./ Compare Out.
	CS4	OH	St/B	External Bus Interface Chip Select 4 Output
	CLKIN2	I	St/B	RTC Count Clock Signal Input

Table 4 Pin Definitions and Functions (cont'd)

Pin	Symbol	Ctrl.	Type	Function
71	P4.3	O0 / I	St/B	Bit 3 of Port 4, General Purpose Input/Output
	CC2_27	O3 / I	St/B	CAPCOM2 CC27IO Capture Inp./ Compare Out.
	CS3	OH	St/B	External Bus Interface Chip Select 3 Output
	RxDC2A	I	St/B	CAN Node 2 Receive Data Input
	T2EUD	I	St/B	GPT1 Timer T2 External Up/Down Control Input
75	P0.0	O0 / I	St/B	Bit 0 of Port 0, General Purpose Input/Output
	U1C0_DOUT	O1	St/B	USIC1 Channel 0 Shift Data Output
	CCU61_ CC60	O3 / I	St/B	CCU61 Channel 0 Input/Output
	A0	OH	St/B	External Bus Interface Address Line 0
	U1C0_DX0A	I	St/B	USIC1 Channel 0 Shift Data Input
76	P4.5	O0 / I	St/B	Bit 5 of Port 4, General Purpose Input/Output
	CC2_29	O3 / I	St/B	CAPCOM2 CC29IO Capture Inp./Compare Out.
77	P4.6	O0 / I	St/B	Bit 6 of Port 4, General Purpose Input/Output
	CC2_30	O3 / I	St/B	CAPCOM2 CC30IO Capture Inp./ Compare Out.
	T4IN	I	St/B	GPT1 Timer T4 Count/Gate Input
78	P2.7	O0 / I	St/B	Bit 7 of Port 2, General Purpose Input/Output
	U0C1_ SELO0	O1	St/B	USIC0 Channel 1 Select/Control 0 Output
	U0C0_ SELO1	O2	St/B	USIC0 Channel 0 Select/Control 1 Output
	CC2_20	O3 / I	St/B	CAPCOM2 CC20IO Capture Inp./ Compare Out.
	A20	OH	St/B	External Bus Interface Address Line 20
	U0C1_DX2C	I	St/B	USIC0 Channel 1 Shift Control Input
	RxDC1C	I	St/B	CAN Node 1 Receive Data Input

Table 4 Pin Definitions and Functions (cont'd)

Pin	Symbol	Ctrl.	Type	Function
79	P0.1	O0 / I	St/B	Bit 1 of Port 0, General Purpose Input/Output
	U1C0_DOUT	O1	St/B	USIC1 Channel 0 Shift Data Output
	TxDC0	O2	St/B	CAN Node 0 Transmit Data Output
	CCU61_ CC61	O3 / I	St/B	CCU61 Channel 1 Input/Output
	A1	OH	St/B	External Bus Interface Address Line 1
	U1C0_DX0B	I	St/B	USIC1 Channel 0 Shift Data Input
	U1C0_DX1A	I	St/B	USIC1 Channel 0 Shift Clock Input
80	P2.8	O0 / I	DP/B	Bit 8 of Port 2, General Purpose Input/Output
	U0C1_ SCLKOUT	O1	DP/B	USIC0 Channel 1 Shift Clock Output
	EXTCLK	O2	DP/B	Programmable Clock Signal Output 1)
	CC2_21	O3 / I	DP/B	CAPCOM2 CC21IO Capture Inp./ Compare Out.
	A21	OH	DP/B	External Bus Interface Address Line 21
	U0C1_DX1D	I	DP/B	USIC0 Channel 1 Shift Clock Input
81	P4.7	O0 / I	St/B	Bit 7 of Port 4, General Purpose Input/Output
	CC2_31	O3 / I	St/B	CAPCOM2 CC31IO Capture Inp./ Compare Out.
	T4EUD	I	St/B	GPT1 Timer T4 External Up/Down Control Input
82	P2.9	O0 / I	St/B	Bit 9 of Port 2, General Purpose Input/Output
	U0C1_DOUT	O1	St/B	USIC0 Channel 1 Shift Data Output
	TxDC1	O2	St/B	CAN Node 1 Transmit Data Output
	CC2_22	O3 / I	St/B	CAPCOM2 CC22IO Capture Inp./ Compare Out.
	A22	OH	St/B	External Bus Interface Address Line 22
	CLKIN1	I	St/B	Clock Signal Input
	TCK_A	I	St/B	JTAG Clock Input

Table 4 Pin Definitions and Functions (cont'd)

Pin	Symbol	Ctrl.	Type	Function
83	P0.2	O0 / I	St/B	Bit 2 of Port 0, General Purpose Input/Output
	U1C0_SCLKOUT	O1	St/B	USIC1 Channel 0 Shift Clock Output
	TxDC0	O2	St/B	CAN Node 0 Transmit Data Output
	CCU61_CC62	O3 / I	St/B	CCU61 Channel 2 Input/Output
	A2	OH	St/B	External Bus Interface Address Line 2
	U1C0_DX1B	I	St/B	USIC1 Channel 0 Shift Clock Input
84	P10.0	O0 / I	St/B	Bit 0 of Port 10, General Purpose Input/Output
	U0C1_DOUT	O1	St/B	USIC0 Channel 1 Shift Data Output
	CCU60_CC60	O2 / I	St/B	CCU60 Channel 0 Input/Output
	AD0	OH / I	St/B	External Bus Interface Address/Data Line 0
	ESR1_2	I	St/B	ESR1 Trigger Input 2
	U0C0_DX0A	I	St/B	USIC0 Channel 0 Shift Data Input
	U0C1_DX0A	I	St/B	USIC0 Channel 1 Shift Data Input
85	P3.0	O0 / I	St/B	Bit 0 of Port 3, General Purpose Input/Output
	U2C0_DOUT	O1	St/B	USIC2 Channel 0 Shift Data Output
	BREQ	OH	St/B	External Bus Request Output
	ESR1_1	I	St/B	ESR1 Trigger Input 1
	U2C0_DX0A	I	St/B	USIC2 Channel 0 Shift Data Input
	RxDC3B	I	St/B	CAN Node 3 Receive Data Input
	U2C0_DX1A	I	St/B	USIC2 Channel 0 Shift Clock Input
86	P10.1	O0 / I	St/B	Bit 1 of Port 10, General Purpose Input/Output
	U0C0_DOUT	O1	St/B	USIC0 Channel 0 Shift Data Output
	CCU60_CC61	O2 / I	St/B	CCU60 Channel 1 Input/Output
	AD1	OH / I	St/B	External Bus Interface Address/Data Line 1
	U0C0_DX0B	I	St/B	USIC0 Channel 0 Shift Data Input
	U0C0_DX1A	I	St/B	USIC0 Channel 0 Shift Clock Input

Table 4 Pin Definitions and Functions (cont'd)

Pin	Symbol	Ctrl.	Type	Function
87	P0.3	O0 / I	St/B	Bit 3 of Port 0, General Purpose Input/Output
	U1C0_SELO0	O1	St/B	USIC1 Channel 0 Select/Control 0 Output
	U1C1_SELO1	O2	St/B	USIC1 Channel 1 Select/Control 1 Output
	CCU61_COUT60	O3	St/B	CCU61 Channel 0 Output
	A3	OH	St/B	External Bus Interface Address Line 3
	U1C0_DX2A	I	St/B	USIC1 Channel 0 Shift Control Input
	RxDC0B	I	St/B	CAN Node 0 Receive Data Input
88	P3.1	O0 / I	St/B	Bit 1 of Port 3, General Purpose Input/Output
	U2C0_DOUT	O1	St/B	USIC2 Channel 0 Shift Data Output
	TxDC3	O2	St/B	CAN Node 3 Transmit Data Output
	HLDA	OH / I	St/B	External Bus Hold Acknowledge Output/Input Output in master mode, input in slave mode.
	U2C0_DX0B	I	St/B	USIC2 Channel 0 Shift Data Input
89	P10.2	O0 / I	St/B	Bit 2 of Port 10, General Purpose Input/Output
	U0C0_SCLKOUT	O1	St/B	USIC0 Channel 0 Shift Clock Output
	CCU60_CC62	O2 / I	St/B	CCU60 Channel 2 Input/Output
	AD2	OH / I	St/B	External Bus Interface Address/Data Line 2
	U0C0_DX1B	I	St/B	USIC0 Channel 0 Shift Clock Input
90	P0.4	O0 / I	St/B	Bit 4 of Port 0, General Purpose Input/Output
	U1C1_SELO0	O1	St/B	USIC1 Channel 1 Select/Control 0 Output
	U1C0_SELO1	O2	St/B	USIC1 Channel 0 Select/Control 1 Output
	CCU61_COUT61	O3	St/B	CCU61 Channel 1 Output
	A4	OH	St/B	External Bus Interface Address Line 4
	U1C1_DX2A	I	St/B	USIC1 Channel 1 Shift Control Input
	RxDC1B	I	St/B	CAN Node 1 Receive Data Input

Table 4 Pin Definitions and Functions (cont'd)

Pin	Symbol	Ctrl.	Type	Function
92	TRef	IO	Sp/1	Control Pin for Core Voltage Generation 2)
93	P3.2	O0 / I	St/B	Bit 2 of Port 3, General Purpose Input/Output
	U2C0_SCLKOUT	O1	St/B	USIC2 Channel 0 Shift Clock Output
	TxDC3	O2	St/B	CAN Node 3 Transmit Data Output
	U2C0_DX1B	I	St/B	USIC2 Channel 0 Shift Clock Input
	HOLD	I	St/B	External Bus Master Hold Request Input
94	P2.10	O0 / I	St/B	Bit 10 of Port 2, General Purpose Input/Output
	U0C1_DOUT	O1	St/B	USIC0 Channel 1 Shift Data Output
	U0C0_SELO3	O2	St/B	USIC0 Channel 0 Select/Control 3 Output
	CC2_23	O3 / I	St/B	CAPCOM2 CC23IO Capture Inp./ Compare Out.
	A23	OH	St/B	External Bus Interface Address Line 23
	U0C1_DX0E	I	St/B	USIC0 Channel 1 Shift Data Input
	CAPIN	I	St/B	GPT2 Register CAPREL Capture Input
95	P10.3	O0 / I	St/B	Bit 3 of Port 10, General Purpose Input/Output
	CCU60_COUT60	O2	St/B	CCU60 Channel 0 Output
	AD3	OH / I	St/B	External Bus Interface Address/Data Line 3
	U0C0_DX2A	I	St/B	USIC0 Channel 0 Shift Control Input
	U0C1_DX2A	I	St/B	USIC0 Channel 1 Shift Control Input
96	P0.5	O0 / I	St/B	Bit 5 of Port 0, General Purpose Input/Output
	U1C1_SCLKOUT	O1	St/B	USIC1 Channel 1 Shift Clock Output
	U1C0_SELO2	O2	St/B	USIC1 Channel 0 Select/Control 2 Output
	CCU61_COUT62	O3	St/B	CCU61 Channel 2 Output
	A5	OH	St/B	External Bus Interface Address Line 5
	U1C1_DX1A	I	St/B	USIC1 Channel 1 Shift Clock Input
	U1C0_DX1C	I	St/B	USIC1 Channel 0 Shift Clock Input

Table 4 Pin Definitions and Functions (cont'd)

Pin	Symbol	Ctrl.	Type	Function
97	P3.3	O0 / I	St/B	Bit 3 of Port 3, General Purpose Input/Output
	U2C0_SELO0	O1	St/B	USIC2 Channel 0 Select/Control 0 Output
	U2C1_SELO1	O2	St/B	USIC2 Channel 1 Select/Control 1 Output
	U2C0_DX2A	I	St/B	USIC2 Channel 0 Shift Control Input
	RxDC3A	I	St/B	CAN Node 3 Receive Data Input
98	P10.4	O0 / I	St/B	Bit 4 of Port 10, General Purpose Input/Output
	U0C0_SELO3	O1	St/B	USIC0 Channel 0 Select/Control 3 Output
	CCU60_COUT61	O2	St/B	CCU60 Channel 1 Output
	AD4	OH / I	St/B	External Bus Interface Address/Data Line 4
	U0C0_DX2B	I	St/B	USIC0 Channel 0 Shift Control Input
	U0C1_DX2B	I	St/B	USIC0 Channel 1 Shift Control Input
99	P3.4	O0 / I	St/B	Bit 4 of Port 3, General Purpose Input/Output
	U2C1_SELO0	O1	St/B	USIC2 Channel 1 Select/Control 0 Output
	U2C0_SELO1	O2	St/B	USIC2 Channel 0 Select/Control 1 Output
	U0C0_SELO4	O3	St/B	USIC0 Channel 0 Select/Control 4 Output
	U2C1_DX2A	I	St/B	USIC2 Channel 1 Shift Control Input
	RxDC4A	I	St/B	CAN Node 4 Receive Data Input
100	P10.5	O0 / I	St/B	Bit 5 of Port 10, General Purpose Input/Output
	U0C1_SCLKOUT	O1	St/B	USIC0 Channel 1 Shift Clock Output
	CCU60_COUT62	O2	St/B	CCU60 Channel 2 Output
	AD5	OH / I	St/B	External Bus Interface Address/Data Line 5
	U0C1_DX1B	I	St/B	USIC0 Channel 1 Shift Clock Input

Table 4 Pin Definitions and Functions (cont'd)

Pin	Symbol	Ctrl.	Type	Function
101	P3.5	O0 / I	St/B	Bit 5 of Port 3, General Purpose Input/Output
	U2C1_SCLKOUT	O1	St/B	USIC2 Channel 1 Shift Clock Output
	U2C0_SELO2	O2	St/B	USIC2 Channel 0 Select/Control 2 Output
	U0C0_SELO5	O3	St/B	USIC0 Channel 0 Select/Control 5 Output
	U2C1_DX1A	I	St/B	USIC2 Channel 1 Shift Clock Input
102	P0.6	O0 / I	St/B	Bit 6 of Port 0, General Purpose Input/Output
	U1C1_DOUT	O1	St/B	USIC1 Channel 1 Shift Data Output
	TxDC1	O2	St/B	CAN Node 1 Transmit Data Output
	CCU61_COUT63	O3	St/B	CCU61 Channel 3 Output
	A6	OH	St/B	External Bus Interface Address Line 6
	U1C1_DX0A	I	St/B	USIC1 Channel 1 Shift Data Input
	CCU61_CTRAPA	I	St/B	CCU61 Emergency Trap Input
	U1C1_DX1B	I	St/B	USIC1 Channel 1 Shift Clock Input
103	P10.6	O0 / I	St/B	Bit 6 of Port 10, General Purpose Input/Output
	U0C0_DOUT	O1	St/B	USIC0 Channel 0 Shift Data Output
	TxDC4	O2	St/B	CAN Node 4 Transmit Data Output
	U1C0_SELO0	O3	St/B	USIC1 Channel 0 Select/Control 0 Output
	AD6	OH / I	St/B	External Bus Interface Address/Data Line 6
	U0C0_DX0C	I	St/B	USIC0 Channel 0 Shift Data Input
	U1C0_DX2D	I	St/B	USIC1 Channel 0 Shift Control Input
	CCU60_CTRAPA	I	St/B	CCU60 Emergency Trap Input

Table 4 Pin Definitions and Functions (cont'd)

Pin	Symbol	Ctrl.	Type	Function
104	P3.6	O0 / I	St/B	Bit 6 of Port 3, General Purpose Input/Output
	U2C1_DOUT	O1	St/B	USIC2 Channel 1 Shift Data Output
	TxDC4	O2	St/B	CAN Node 4 Transmit Data Output
	U0C0_SELO6	O3	St/B	USIC0 Channel 0 Select/Control 6 Output
	U2C1_DX0A	I	St/B	USIC2 Channel 1 Shift Data Input
	U2C1_DX1B	I	St/B	USIC2 Channel 1 Shift Clock Input
105	P10.7	O0 / I	St/B	Bit 7 of Port 10, General Purpose Input/Output
	U0C1_DOUT	O1	St/B	USIC0 Channel 1 Shift Data Output
	CCU60_COUT63	O2	St/B	CCU60 Channel 3 Output
	AD7	OH / I	St/B	External Bus Interface Address/Data Line 7
	U0C1_DX0B	I	St/B	USIC0 Channel 1 Shift Data Input
	CCU60_CCPOS0A	I	St/B	CCU60 Position Input 0
	RxDC4C	I	St/B	CAN Node 4 Receive Data Input
106	P0.7	O0 / I	St/B	Bit 7 of Port 0, General Purpose Input/Output
	U1C1_DOUT	O1	St/B	USIC1 Channel 1 Shift Data Output
	U1C0_SELO3	O2	St/B	USIC1 Channel 0 Select/Control 3 Output
	A7	OH	St/B	External Bus Interface Address Line 7
	U1C1_DX0B	I	St/B	USIC1 Channel 1 Shift Data Input
	CCU61_CTRAPB	I	St/B	CCU61 Emergency Trap Input
107	P3.7	O0 / I	St/B	Bit 7 of Port 3, General Purpose Input/Output
	U2C1_DOUT	O1	St/B	USIC2 Channel 1 Shift Data Output
	U2C0_SELO3	O2	St/B	USIC2 Channel 0 Select/Control 3 Output
	U0C0_SELO7	O3	St/B	USIC0 Channel 0 Select/Control 7 Output
	U2C1_DX0B	I	St/B	USIC2 Channel 1 Shift Data Input

Table 4 Pin Definitions and Functions (cont'd)

Pin	Symbol	Ctrl.	Type	Function
111	P1.0	O0 / I	St/B	Bit 0 of Port 1, General Purpose Input/Output
	U1C0_MCLKOUT	O1	St/B	USIC1 Channel 0 Master Clock Output
	U1C0_SELO4	O2	St/B	USIC1 Channel 0 Select/Control 4 Output
	A8	OH	St/B	External Bus Interface Address Line 8
	ESR1_3	I	St/B	ESR1 Trigger Input 3
	EX0BINA	I	St/B	External Interrupt Trigger Input
	CCU62_CTRAPB	I	St/B	CCU62 Emergency Trap Input
112	P9.0	O0 / I	St/B	Bit 0 of Port 9, General Purpose Input/Output
	CCU63_CC60	O1 / I	St/B	CCU63 Channel 0 Input/Output
113	P10.8	O0 / I	St/B	Bit 8 of Port 10, General Purpose Input/Output
	U0C0_MCLKOUT	O1	St/B	USIC0 Channel 0 Master Clock Output
	U0C1_SELO0	O2	St/B	USIC0 Channel 1 Select/Control 0 Output
	AD8	OH / I	St/B	External Bus Interface Address/Data Line 8
	CCU60_CCPOS1A	I	St/B	CCU60 Position Input 1
	U0C0_DX1C	I	St/B	USIC0 Channel 0 Shift Clock Input
	$\overline{\text{BRKIN}}_B$	I	St/B	OCDS Break Signal Input
114	P9.1	O0 / I	St/B	Bit 1 of Port 9, General Purpose Input/Output
	CCU63_CC61	O1 / I	St/B	CCU63 Channel 1 Input/Output

Table 4 Pin Definitions and Functions (cont'd)

Pin	Symbol	Ctrl.	Type	Function
115	P10.9	O0 / I	St/B	Bit 9 of Port 10, General Purpose Input/Output
	U0C0_SELO4	O1	St/B	USIC0 Channel 0 Select/Control 4 Output
	U0C1_MCLKOUT	O2	St/B	USIC0 Channel 1 Master Clock Output
	AD9	OH / I	St/B	External Bus Interface Address/Data Line 9
	CCU60_CCPOS2A	I	St/B	CCU60 Position Input 2
	TCK_B	I	St/B	JTAG Clock Input
116	P1.1	O0 / I	St/B	Bit 1 of Port 1, General Purpose Input/Output
	CCU62_COUT62	O1	St/B	CCU62 Channel 2 Output
	U1C0_SELO5	O2	St/B	USIC1 Channel 0 Select/Control 5 Output
	U2C1_DOUT	O3	St/B	USIC2 Channel 1 Shift Data Output
	A9	OH	St/B	External Bus Interface Address Line 9
	ESR2_3	I	St/B	ESR2 Trigger Input 3
	EX1BINA	I	St/B	External Interrupt Trigger Input
	U2C1_DX0C	I	St/B	USIC2 Channel 1 Shift Data Input
117	P10.10	O0 / I	St/B	Bit 10 of Port 10, General Purpose Input/Output
	U0C0_SELO0	O1	St/B	USIC0 Channel 0 Select/Control 0 Output
	CCU60_COUT63	O2	St/B	CCU60 Channel 3 Output
	AD10	OH / I	St/B	External Bus Interface Address/Data Line 10
	U0C0_DX2C	I	St/B	USIC0 Channel 0 Shift Control Input
	TDI_B	I	St/B	JTAG Test Data Input
	U0C1_DX1A	I	St/B	USIC0 Channel 1 Shift Clock Input

Table 4 Pin Definitions and Functions (cont'd)

Pin	Symbol	Ctrl.	Type	Function
118	P10.11	O0 / I	St/B	Bit 11 of Port 10, General Purpose Input/Output
	U1C0_SCLKOUT	O1	St/B	USIC1 Channel 0 Shift Clock Output
	$\overline{\text{BRKOUT}}$	O2	St/B	OCDS Break Signal Output
	AD11	OH / I	St/B	External Bus Interface Address/Data Line 11
	U1C0_DX1D	I	St/B	USIC1 Channel 0 Shift Clock Input
	RxDC2B	I	St/B	CAN Node 2 Receive Data Input
	TMS_B	I	St/B	JTAG Test Mode Selection Input
119	P9.2	O0 / I	St/B	Bit 2 of Port 9, General Purpose Input/Output
	CCU63_CC62	O1 / I	St/B	CCU63 Channel 2 Input/Output
120	P1.2	O0 / I	St/B	Bit 2 of Port 1, General Purpose Input/Output
	CCU62_CC62	O1 / I	St/B	CCU62 Channel 2 Input/Output
	U1C0_SELO6	O2	St/B	USIC1 Channel 0 Select/Control 6 Output
	U2C1_SCLKOUT	O3	St/B	USIC2 Channel 1 Shift Clock Output
	A10	OH	St/B	External Bus Interface Address Line 10
	ESR1_4	I	St/B	ESR1 Trigger Input 4
	CCU61_T12HRB	I	St/B	External Run Control Input for T12 of CCU61
	EX2AINA	I	St/B	External Interrupt Trigger Input
	U2C1_DX0D	I	St/B	USIC2 Channel 1 Shift Data Input
	U2C1_DX1C	I	St/B	USIC2 Channel 1 Shift Clock Input
121	P10.12	O0 / I	St/B	Bit 12 of Port 10, General Purpose Input/Output
	U1C0_DOUT	O1	St/B	USIC1 Channel 0 Shift Data Output
	TxDC2	O2	St/B	CAN Node 2 Transmit Data Output
	TDO_B	O3	St/B	JTAG Test Data Output
	AD12	OH / I	St/B	External Bus Interface Address/Data Line 12
	U1C0_DX0C	I	St/B	USIC1 Channel 0 Shift Data Input
	U1C0_DX1E	I	St/B	USIC1 Channel 0 Shift Clock Input

Table 4 Pin Definitions and Functions (cont'd)

Pin	Symbol	Ctrl.	Type	Function
122	P9.3	O0 / I	St/B	Bit 3 of Port 9, General Purpose Input/Output
	CCU63_COUT60	O1	St/B	CCU63 Channel 0 Output
	$\overline{\text{BRKOUT}}$	O2	St/B	OCDS Break Signal Output
123	P10.13	O0 / I	St/B	Bit 13 of Port 10, General Purpose Input/Output
	U1C0_DOUT	O1	St/B	USIC1 Channel 0 Shift Data Output
	TxDC3	O2	St/B	CAN Node 3 Transmit Data Output
	U1C0_SELO3	O3	St/B	USIC1 Channel 0 Select/Control 3 Output
	$\overline{\text{WR/WRL}}$	OH	St/B	External Bus Interface Write Strobe Output Active for each external write access, when $\overline{\text{WR}}$, active for ext. writes to the low byte, when $\overline{\text{WRL}}$.
	U1C0_DX0D	I	St/B	USIC1 Channel 0 Shift Data Input
124	P1.3	O0 / I	St/B	Bit 3 of Port 1, General Purpose Input/Output
	CCU62_COUT63	O1	St/B	CCU62 Channel 3 Output
	U1C0_SELO7	O2	St/B	USIC1 Channel 0 Select/Control 7 Output
	U2C0_SELO4	O3	St/B	USIC2 Channel 0 Select/Control 4 Output
	A11	OH	St/B	External Bus Interface Address Line 11
	ESR2_4	I	St/B	ESR2 Trigger Input 4
	CCU62_T12HRB	I	St/B	External Run Control Input for T12 of CCU62
	EX3AINA	I	St/B	External Interrupt Trigger Input
125	P9.4	O0 / I	St/B	Bit 4 of Port 9, General Purpose Input/Output
	CCU63_COUT61	O1	St/B	CCU63 Channel 1 Output
	U2C0_DOUT	O2	St/B	USIC2 Channel 0 Shift Data Output

Table 4 Pin Definitions and Functions (cont'd)

Pin	Symbol	Ctrl.	Type	Function
126	P9.5	O0 / I	St/B	Bit 5 of Port 9, General Purpose Input/Output
	CCU63_COUT62	O1	St/B	CCU63 Channel 2 Output
	U2C0_DOUT	O2	St/B	USIC2 Channel 0 Shift Data Output
	U2C0_DX0E	I	St/B	USIC2 Channel 0 Shift Data Input
	CCU60_CCPOS2B	I	St/B	CCU60 Position Input 2
128	P10.14	O0 / I	St/B	Bit 14 of Port 10, General Purpose Input/Output
	U1C0_SELO1	O1	St/B	USIC1 Channel 0 Select/Control 1 Output
	U0C1_DOUT	O2	St/B	USIC0 Channel 1 Shift Data Output
	$\overline{\text{RD}}$	OH	St/B	External Bus Interface Read Strobe Output
	ESR2_2	I	St/B	ESR2 Trigger Input 2
	U0C1_DX0C	I	St/B	USIC0 Channel 1 Shift Data Input
	RxDC3C	I	St/B	CAN Node 3 Receive Data Input
129	P1.4	O0 / I	St/B	Bit 4 of Port 1, General Purpose Input/Output
	CCU62_COUT61	O1	St/B	CCU62 Channel 1 Output
	U1C1_SELO4	O2	St/B	USIC1 Channel 1 Select/Control 4 Output
	U2C0_SELO5	O3	St/B	USIC2 Channel 0 Select/Control 5 Output
	A12	OH	St/B	External Bus Interface Address Line 12
	U2C0_DX2B	I	St/B	USIC2 Channel 0 Shift Control Input
	130	P10.15	O0 / I	St/B
U1C0_SELO2		O1	St/B	USIC1 Channel 0 Select/Control 2 Output
U0C1_DOUT		O2	St/B	USIC0 Channel 1 Shift Data Output
U1C0_DOUT		O3	St/B	USIC1 Channel 0 Shift Data Output
ALE		OH	St/B	External Bus Interf. Addr. Latch Enable Output
U0C1_DX1C		I	St/B	USIC0 Channel 1 Shift Clock Input

Table 4 Pin Definitions and Functions (cont'd)

Pin	Symbol	Ctrl.	Type	Function
131	P1.5	O0 / I	St/B	Bit 5 of Port 1, General Purpose Input/Output
	CCU62_COUT60	O1	St/B	CCU62 Channel 0 Output
	U1C1_SELO3	O2	St/B	USIC1 Channel 1 Select/Control 3 Output
	BRKOUT	O3	St/B	OCDS Break Signal Output
	A13	OH	St/B	External Bus Interface Address Line 13
	U2C0_DX0C	I	St/B	USIC2 Channel 0 Shift Data Input
132	P9.6	O0 / I	St/B	Bit 6 of Port 9, General Purpose Input/Output
	CCU63_COUT63	O1	St/B	CCU63 Channel 3 Output
	CCU63_COUT62	O2	St/B	CCU63 Channel 2 Output
	CCU63_CTRAPA	I	St/B	CCU63 Emergency Trap Input
	CCU60_CCPOS1B	I	St/B	CCU60 Position Input 1
133	P1.6	O0 / I	St/B	Bit 6 of Port 1, General Purpose Input/Output
	CCU62_CC61	O1 / I	St/B	CCU62 Channel 1 Input/Output
	U1C1_SELO2	O2	St/B	USIC1 Channel 1 Select/Control 2 Output
	U2C0_DOUT	O3	St/B	USIC2 Channel 0 Shift Data Output
	A14	OH	St/B	External Bus Interface Address Line 14
	U2C0_DX0D	I	St/B	USIC2 Channel 0 Shift Data Input
134	P9.7	O0 / I	St/B	Bit 7 of Port 9, General Purpose Input/Output
	CCU63_CTRAPB	I	St/B	CCU63 Emergency Trap Input
	U2C0_DX1D	I	St/B	USIC2 Channel 0 Shift Clock Input
	CCU60_CCPOS0B	I	St/B	CCU60 Position Input 0

Table 4 Pin Definitions and Functions (cont'd)

Pin	Symbol	Ctrl.	Type	Function
135	P1.7	O0 / I	St/B	Bit 7 of Port 1, General Purpose Input/Output
	CCU62_ CC60	O1 / I	St/B	CCU62 Channel 0 Input/Output
	U1C1_ MCLKOUT	O2	St/B	USIC1 Channel 1 Master Clock Output
	U2C0_ SCLKOUT	O3	St/B	USIC2 Channel 0 Shift Clock Output
	A15	OH	St/B	External Bus Interface Address Line 15
	U2C0_DX1C	I	St/B	USIC2 Channel 0 Shift Clock Input
136	XTAL2	O	Sp/1	Crystal Oscillator Amplifier Output
137	XTAL1	I	Sp/1	Crystal Oscillator Amplifier Input To clock the device from an external source, drive XTAL1, while leaving XTAL2 unconnected. Voltages on XTAL1 must comply to the core supply voltage V_{DD1} .
138	$\overline{\text{PORST}}$	I	In/B	Power On Reset Input A low level at this pin resets the XE167 completely. A spike filter suppresses input pulses <10 ns. Input pulses >100 ns safely pass the filter. The minimum duration for a safe recognition should be 120 ns. An internal pullup device will hold this pin high when nothing is driving it.
139	$\overline{\text{ESR1}}$	O0 / I	St/B	External Service Request 1
	U1C0_DX0F	I	St/B	USIC1 Channel 0 Shift Data Input
	U1C0_DX2C	I	St/B	USIC1 Channel 0 Shift Control Input
	U1C1_DX0C	I	St/B	USIC1 Channel 1 Shift Data Input
	U1C1_DX2B	I	St/B	USIC1 Channel 1 Shift Control Input
	U2C1_DX2C	I	St/B	USIC2 Channel 1 Shift Control Input
	EX0AINB	I	St/B	External Interrupt Trigger Input

Table 4 Pin Definitions and Functions (cont'd)

Pin	Symbol	Ctrl.	Type	Function
140	$\overline{\text{ESR2}}$	O0 / I	St/B	External Service Request 2
	U1C1_DX0D	I	St/B	USIC1 Channel 1 Shift Data Input
	U1C1_DX2C	I	St/B	USIC1 Channel 1 Shift Control Input
	U2C1_DX0E	I	St/B	USIC1 Channel 1 Shift Data Input
	U2C1_DX2B	I	St/B	USIC2 Channel 1 Shift Control Input
	EX1AINB	I	St/B	External Interrupt Trigger Input
141	$\overline{\text{ESR0}}$	O0 / I	St/B	External Service Request 0 <i>Note: After power-up, ESR0 operates as open-drain bidirectional reset with a weak pull-up.</i>
	U1C0_DX0E	I	St/B	USIC1 Channel 0 Shift Data Input
	U1C0_DX2B	I	St/B	USIC1 Channel 0 Shift Control Input
142	P8.6	O0 / I	St/B	Bit 6 of Port 8, General Purpose Input/Output
	CCU60_COUT63	O1	St/B	CCU60 Channel 3 Output
	CCU60_CTRAPB	I	St/B	CCU60 Emergency Trap Input
	$\overline{\text{BRKIN_D}}$	I	St/B	OCDS Break Signal Input
143	P8.5	O0 / I	St/B	Bit 5 of Port 8, General Purpose Input/Output
	CCU60_COUT62	O1	St/B	CCU60 Channel 2 Output
	TCK_D	I	St/B	JTAG Clock Input
15	V_{DDIM}	-	PS/M	Digital Core Supply Voltage for Domain M Decouple with a ceramic capacitor, see Table 12 for details.
54, 91, 127	V_{DDI1}	-	PS/1	Digital Core Supply Voltage for Domain 1 Decouple with a ceramic capacitor, see Table 12 for details. All V_{DDI1} pins must be connected to each other.
20	V_{DDPA}	-	PS/A	Digital Pad Supply Voltage for Domain A Connect decoupling capacitors to adjacent $V_{\text{DDP}}/V_{\text{SS}}$ pin pairs as close as possible to the pins. <i>Note: The A/D_Converters and ports P5, P6, and P15 are fed from supply voltage V_{DDPA}.</i>

Table 4 Pin Definitions and Functions (cont'd)

Pin	Symbol	Ctrl.	Type	Function
2, 36, 38, 72, 74, 108, 110, 144	V_{DDPB}	-	PS/B	Digital Pad Supply Voltage for Domain B Connect decoupling capacitors to adjacent V_{DDP}/V_{SS} pin pairs as close as possible to the pins. <i>Note: The on-chip voltage regulators and all ports except P5, P6, and P15 are fed from supply voltage V_{DDPB}.</i>
1, 37, 73, 109	V_{SS}	-	PS/--	Digital Ground All V_{SS} pins must be connected to the ground-line or ground-plane. <i>Note: Also the exposed pad is connected to V_{SS}. The respective board area must be connected to ground (if soldered) or left free.</i>

- 1) To generate the reference clock output for bus timing measurement, f_{SYS} must be selected as source for EXTCLK and P2.8 must be selected as output pin. Also the high-speed clock pad must be enabled. This configuration is referred to as reference clock output signal CLKOUT.
- 2) Pin TRef was used to control the core voltage generation in step AA. For that step, pin TRef must be connected to V_{DDPB} . This connection is no more required from step AB on. For the current step, pin TRef is logically not connected. Future derivatives will feature an additional general purpose IO pin at this position.

3 Functional Description

The architecture of the XE167 combines advantages of RISC, CISC, and DSP processors with an advanced peripheral subsystem in a well-balanced design. On-chip memory blocks allow the design of compact systems-on-silicon with maximum performance suited for computing, control, and communication.

The on-chip memory blocks (program code memory and SRAM, dual-port RAM, data SRAM) and the generic peripherals are connected to the CPU by separate high-speed buses. Another bus, the LXBus, connects additional on-chip resources and external resources (see [Figure 3](#)). This bus structure enhances overall system performance by enabling the concurrent operation of several subsystems of the XE167.

The block diagram gives an overview of the on-chip components and the advanced internal bus structure of the XE167.

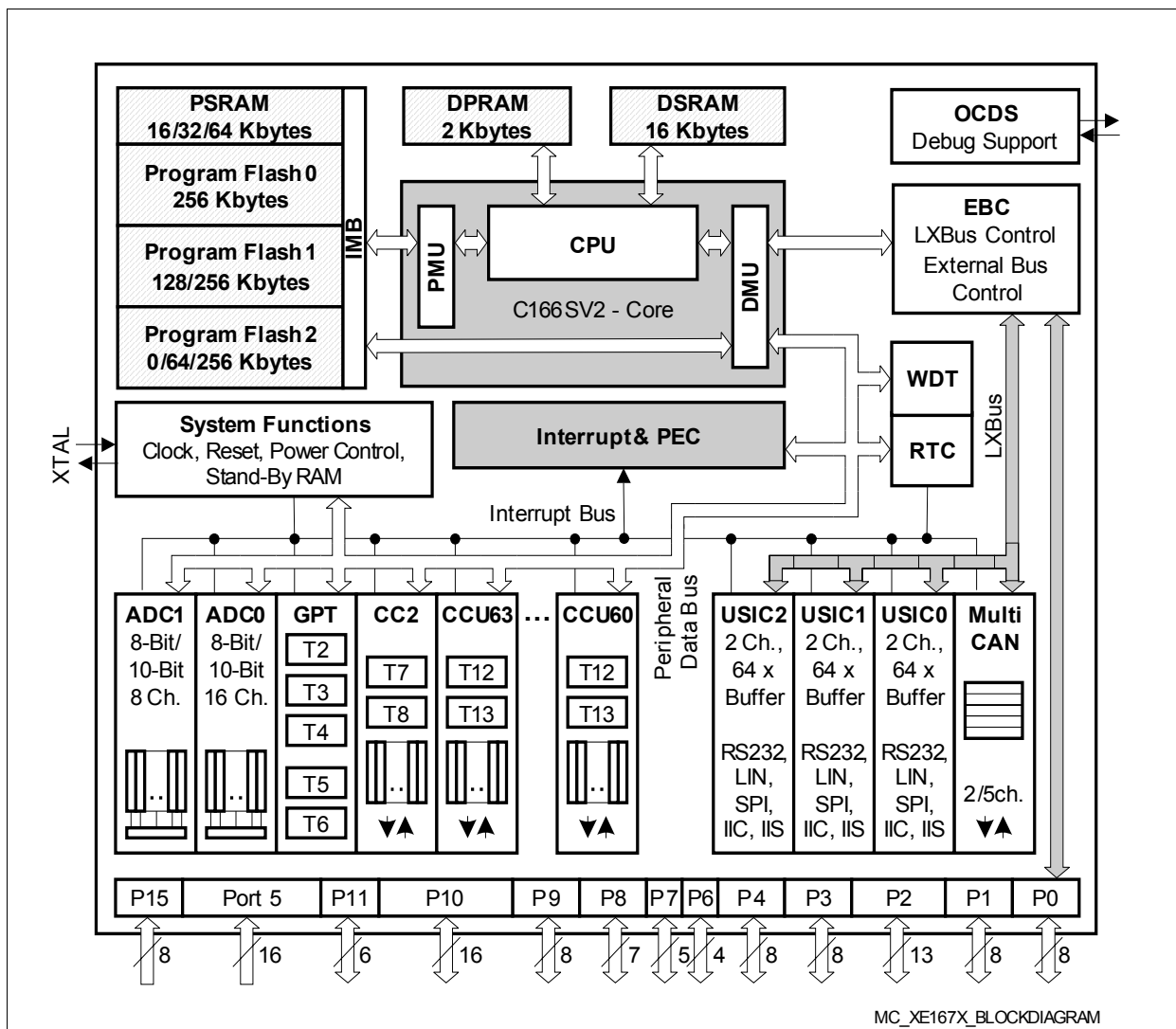

Figure 3 Block Diagram

3.1 Memory Subsystem and Organization

The memory space of the XE167 is configured in the von Neumann architecture. In this architecture all internal and external resources, including code memory, data memory, registers and I/O ports, are organized in the same linear address space.

Table 5 XE167 Memory Map

Address Area	Start Loc.	End Loc.	Area Size ¹⁾	Notes
IMB register space	FF'FF00 _H	FF'FFFF _H	256 Bytes	–
Reserved (Access trap)	F0'0000 _H	FF'FEFF _H	<1 Mbyte	Minus IMB registers
Reserved for EPSRAM	E9'0000 _H	EF'FFFF _H	448 Kbytes	Mirrors EPSRAM
Emulated PSRAM	E8'0000 _H	E8'FFFF _H	64 Kbytes	Flash timing
Reserved for PSRAM	E1'0000 _H	E7'FFFF _H	448 Kbytes	Mirrors PSRAM
Program SRAM	E0'0000 _H	E0'FFFF _H	64 Kbytes	Maximum speed
Reserved for pr. mem.	CC'0000 _H	DF'FFFF _H	<1.25 Mbytes	–
Program Flash 2	C8'0000 _H	CB'FFFF _H	256 Kbytes	–
Program Flash 1	C4'0000 _H	C7'FFFF _H	256 Kbytes	–
Program Flash 0	C0'0000 _H	C3'FFFF _H	256 Kbytes	2)
External memory area	40'0000 _H	BF'FFFF _H	8 Mbytes	–
Available Ext. IO area ³⁾	20'5800 _H	3F'FFFF _H	< 2 Mbytes	Minus USIC/CAN
USIC registers	20'4000 _H	20'57FF _H	6 Kbytes	Accessed via EBC
MultiCAN registers	20'0000 _H	20'3FFF _H	16 Kbytes	Accessed via EBC
External memory area	01'0000 _H	1F'FFFF _H	< 2 Mbytes	Minus segment 0
SFR area	00'FE00 _H	00'FFFF _H	0.5 Kbyte	–
Dual-Port RAM	00'F600 _H	00'FDFF _H	2 Kbytes	–
Reserved for DPRAM	00'F200 _H	00'F5FF _H	1 Kbyte	–
ESFR area	00'F000 _H	00'F1FF _H	0.5 Kbyte	–
XSFR area	00'E000 _H	00'EFFF _H	4 Kbytes	–
Data SRAM	00'A000 _H	00'DFFF _H	16 Kbytes	–
Reserved for DSRAM	00'8000 _H	00'9FFF _H	8 Kbytes	–
External memory area	00'0000 _H	00'7FFF _H	32 Kbytes	–

1) The areas marked with “<” are slightly smaller than indicated. See column “Notes”.

2) The uppermost 4-Kbyte sector of the first Flash segment is reserved for internal use (C0'F000_H to C0'FFFF_H).

3) Several pipeline optimizations are not active within the external IO area. This is necessary to control external peripherals properly.

Functional Description

This common memory space consists of 16 Mbytes organized as 256 segments of 64 Kbytes; each segment contains four data pages of 16 Kbytes. The entire memory space can be accessed byte-wise or word-wise. Portions of the on-chip DPRAM and the register spaces (ESFR/SFR) additionally are directly bit addressable.

The internal data memory areas and the Special Function Register areas (SFR and ESFR) are mapped into segment 0, the system segment.

The Program Management Unit (PMU) handles all code fetches and, therefore, controls access to the program memories such as Flash memory and PSRAM.

The Data Management Unit (DMU) handles all data transfers and, therefore, controls access to the DSRAM and the on-chip peripherals.

Both units (PMU and DMU) are connected to the high-speed system bus so that they can exchange data. This is required if operands are read from program memory, code or data is written to the PSRAM, code is fetched from external memory, or data is read from or written to external resources. These include peripherals on the LXBus such as USIC or MultiCAN. The system bus allows concurrent two-way communication for maximum transfer performance.

Up to 64 Kbytes of on-chip Program SRAM (PSRAM) are provided to store user code or data. The PSRAM is accessed via the PMU and is optimized for code fetches. A section of the PSRAM with programmable size can be write-protected.

Note: The actual size of the PSRAM depends on the chosen derivative (see [Table 1](#)).

16 Kbytes of on-chip Data SRAM (DSRAM) are used for storage of general user data. The DSRAM is accessed via a separate interface and is optimized for data access.

2 Kbytes of on-chip Dual-Port RAM (DPRAM) provide storage for user-defined variables, for the system stack, and for general purpose register banks. A register bank can consist of up to 16 word-wide (R0 to R15) and/or byte-wide (RL0, RH0, ..., RL7, RH7) General Purpose Registers (GPRs).

The upper 256 bytes of the DPRAM are directly bit addressable. When used by a GPR, any location in the DPRAM is bit addressable.

1 Kbyte of on-chip Stand-By SRAM (SBRAM) provides storage for system-relevant user data that must be preserved while the major part of the device is powered down. The SBRAM is accessed via a specific interface and is powered in domain M.

Functional Description

1024 bytes (2 × 512 bytes) of the address space are reserved for the Special Function Register areas (SFR space and ESFR space). SFRs are word-wide registers which are used to control and monitor functions of the different on-chip units. Unused SFR addresses are reserved for future members of the XE166 Family. In order to ensure upward compatibility they should either not be accessed or written with zeros.

In order to meet the requirements of designs where more memory is required than is available on chip, up to 12 Mbytes (approximately, see [Table 5](#)) of external RAM and/or ROM can be connected to the microcontroller. The External Bus Interface also provides access to external peripherals.

Up to 768 Kbytes of on-chip Flash memory store code, constant data, and control data. The on-chip Flash memory consists of up to three modules with a maximum capacity of 256 Kbytes each. Each module is organized in 4-Kbyte sectors.

The uppermost 4-Kbyte sector of segment 0 (located in Flash module 0) is used internally to store operation control parameters and protection information.

Note: The actual size of the Flash memory depends on the chosen derivative (see [Table 1](#)).

Each sector can be separately write protected¹⁾, erased and programmed (in blocks of 128 Bytes). The complete Flash area can be read-protected. A user-defined password sequence temporarily unlocks protected areas. The Flash modules combine 128-bit read access with protected and efficient writing algorithms for programming and erasing. Dynamic error correction provides extremely high read data security for all read access operations. Access to different Flash modules can be executed in parallel.

For Flash parameters, please see [Section 4.5](#).

1) To save control bits, sectors are clustered for protection purposes, they remain separate for programming/erasing.

3.2 External Bus Controller

All external memory access operations are performed by a special on-chip External Bus Controller (EBC). The EBC also controls access to resources connected to the on-chip LXBus (MultiCAN and the USIC modules). The LXBus is an internal representation of the external bus that allows access to integrated peripherals and modules in the same way as to external components.

The EBC can be programmed either to Single Chip Mode, when no external memory is required, or to an external bus mode with the following selections¹⁾:

- Address Bus Width with a range of 0 ... 24-bit
- Data Bus Width 8-bit or 16-bit
- Bus Operation Multiplexed or Demultiplexed

The bus interface uses Port 10 and Port 2 for addresses and data. In the demultiplexed bus modes, the lower addresses are output separately on Port 0 and Port 1. The number of active segment address lines is selectable, restricting the external address space to 8 Mbytes ... 64 Kbytes. This is required when interface lines shall be assigned to Port 2.

Up to five external $\overline{\text{CS}}$ signals (four windows plus default) can be generated and output on Port 4 in order to save external glue logic. External modules can be directly connected to the common address/data bus and their individual select lines.

A $\overline{\text{HOLD}}/\overline{\text{HLDA}}$ protocol is available for bus arbitration; this allows the sharing of external resources with other bus masters. The bus arbitration is enabled by software, after which pins P3.0 ... P3.2 ($\overline{\text{BREQ}}$, $\overline{\text{HLDA}}$, $\overline{\text{HOLD}}$) are automatically controlled by the EBC. In Master Mode (default after reset) the $\overline{\text{HLDA}}$ pin is an output. In Slave Mode pin $\overline{\text{HLDA}}$ is switched to be an input. This allows the direct connection of the slave controller to another master controller without glue logic.

Important timing characteristics of the external bus interface are programmable (with registers TCONCSx/FCONCSx) to allow the user to adapt it to a wide range of different types of memories and external peripherals.

Access to very slow memories or modules with varying access times is supported by a special 'Ready' function. The active level of the control input signal is selectable.

In addition, up to four independent address windows may be defined (using registers ADDRSELx) to control access to resources with different bus characteristics. These address windows are arranged hierarchically where window 4 overrides window 3, and window 2 overrides window 1. All accesses to locations not covered by these four address windows are controlled by TCONCS0/FCONCS0. The currently active window can generate a chip select signal.

The external bus timing is based on the rising edge of the reference clock output CLKOUT. The external bus protocol is compatible with that of the standard C166 Family.

1) Bus modes are switched dynamically if several address windows with different mode settings are used.

3.3 Central Processing Unit (CPU)

The core of the CPU consists of a 5-stage execution pipeline with a 2-stage instruction-fetch pipeline, a 16-bit arithmetic and logic unit (ALU), a 32-bit/40-bit multiply and accumulate unit (MAC), a register-file providing three register banks, and dedicated SFRs. The ALU features a multiply-and-divide unit, a bit-mask generator, and a barrel shifter.

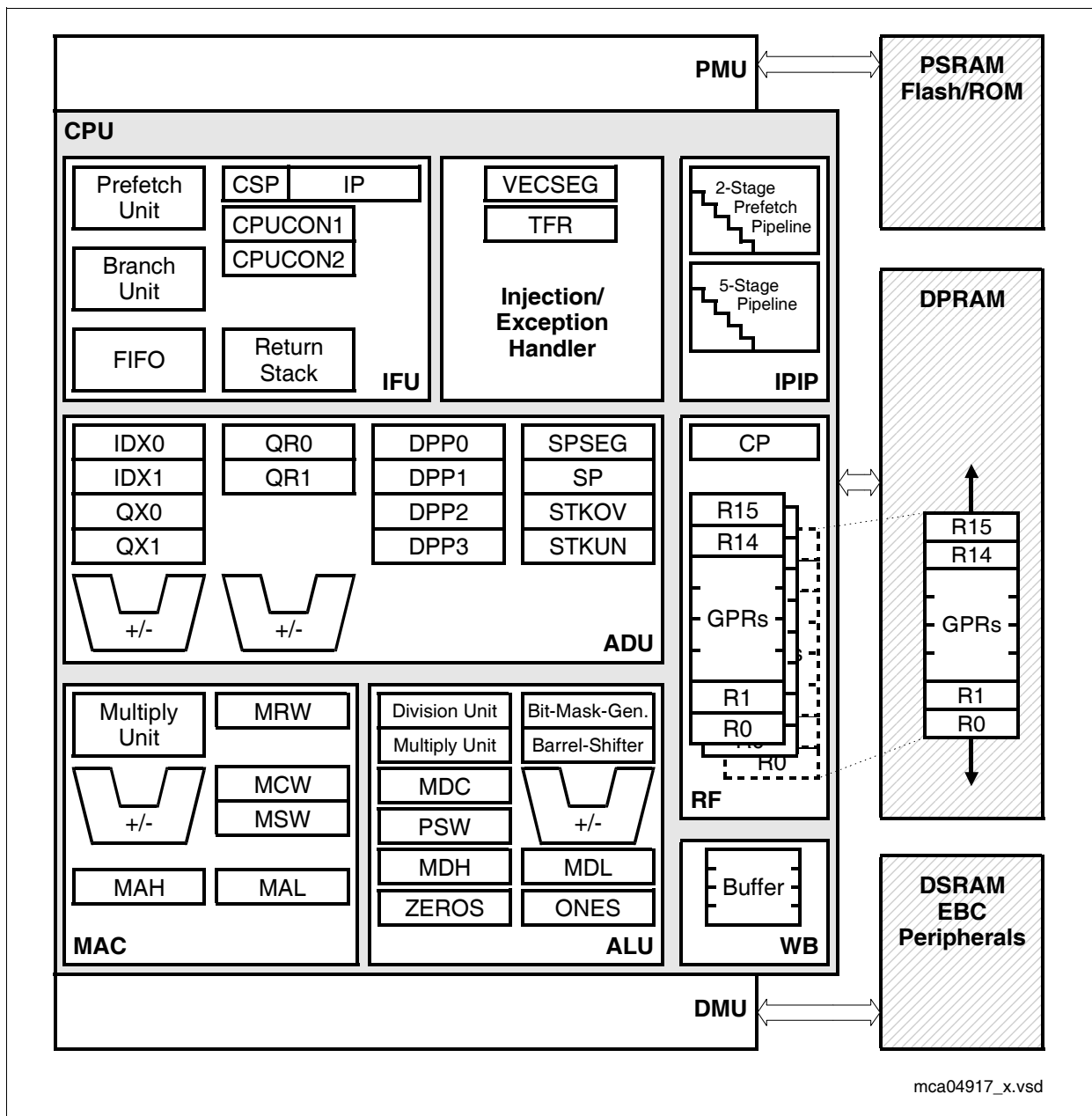

Figure 4 CPU Block Diagram

Functional Description

With this hardware most XE167 instructions can be executed in a single machine cycle of 12.5 ns with an 80-MHz CPU clock. For example, shift and rotate instructions are always processed during one machine cycle, no matter how many bits are shifted. Also, multiplication and most MAC instructions execute in one cycle. All multiple-cycle instructions have been optimized so that they can be executed very fast; for example, a 32-/16-bit division is started within 4 cycles while the remaining cycles are executed in the background. Another pipeline optimization, the branch target prediction, eliminates the execution time of branch instructions if the prediction was correct.

The CPU has a register context consisting of up to three register banks with 16 word-wide GPRs each at its disposal. One of these register banks is physically allocated within the on-chip DPRAM area. A Context Pointer (CP) register determines the base address of the active register bank accessed by the CPU at any time. The number of these register bank copies is only restricted by the available internal RAM space. For easy parameter passing, a register bank may overlap others.

A system stack of up to 32 Kwords is provided for storage of temporary data. The system stack can be allocated to any location within the address space (preferably in the on-chip RAM area); it is accessed by the CPU with the stack pointer (SP) register. Two separate SFRs, STKOV and STKUN, are implicitly compared with the stack pointer value during each stack access to detect stack overflow or underflow.

The high performance of the CPU hardware implementation can be best utilized by the programmer with the highly efficient XE167 instruction set. This includes the following instruction classes:

- Standard Arithmetic Instructions
- DSP-Oriented Arithmetic Instructions
- Logical Instructions
- Boolean Bit Manipulation Instructions
- Compare and Loop Control Instructions
- Shift and Rotate Instructions
- Prioritize Instruction
- Data Movement Instructions
- System Stack Instructions
- Jump and Call Instructions
- Return Instructions
- System Control Instructions
- Miscellaneous Instructions

The basic instruction length is either 2 or 4 bytes. Possible operand types are bits, bytes and words. A variety of direct, indirect or immediate addressing modes are provided to specify the required operands.

3.4 Interrupt System

With a minimum interrupt response time of $7/11^{1)}$ CPU clocks (in the case of internal program execution), the XE167 can react quickly to the occurrence of non-deterministic events.

The architecture of the XE167 supports several mechanisms for fast and flexible response to service requests; these can be generated from various sources internal or external to the microcontroller. Any of these interrupt requests can be programmed to be serviced by the Interrupt Controller or by the Peripheral Event Controller (PEC).

Where in a standard interrupt service the current program execution is suspended and a branch to the interrupt vector table is performed, just one cycle is 'stolen' from the current CPU activity to perform a PEC service. A PEC service implies a single byte or word data transfer between any two memory locations with an additional increment of either the PEC source pointer, the destination pointer, or both. An individual PEC transfer counter is implicitly decremented for each PEC service except when performing in the continuous transfer mode. When this counter reaches zero, a standard interrupt is performed to the corresponding source-related vector location. PEC services are particularly well suited to supporting the transmission or reception of blocks of data. The XE167 has eight PEC channels, each with fast interrupt-driven data transfer capabilities.

Each of the possible interrupt nodes has a separate control register containing an interrupt request flag, an interrupt enable flag and an interrupt priority bitfield. Each node can be programmed by its related register to one of sixteen interrupt priority levels. Once accepted by the CPU, an interrupt service can only be interrupted by a higher-priority service request. For standard interrupt processing, each possible interrupt node has a dedicated vector location.

Fast external interrupt inputs can service external interrupts with high-precision requirements. These fast interrupt inputs feature programmable edge detection (rising edge, falling edge, or both edges).

Software interrupts are supported by the 'TRAP' instruction in combination with an individual trap (interrupt) number.

Table 6 shows all of the possible XE167 interrupt sources and the corresponding hardware-related interrupt flags, vectors, vector locations and trap (interrupt) numbers.

Note: Interrupt nodes which are not assigned to peripherals (unassigned nodes) may be used to generate software-controlled interrupt requests by setting the respective interrupt request bit (xIR).

1) Depending if the jump cache is used or not.

Table 6 XE167 Interrupt Nodes

Source of Interrupt or PEC Service Request	Control Register	Vector Location ¹⁾	Trap Number
CAPCOM Register 16, or ERU Request 0	CC2_CC16IC	xx'0040 _H	10 _H / 16 _D
CAPCOM Register 17, or ERU Request 1	CC2_CC17IC	xx'0044 _H	11 _H / 17 _D
CAPCOM Register 18, or ERU Request 2	CC2_CC18IC	xx'0048 _H	12 _H / 18 _D
CAPCOM Register 19, or ERU Request 3	CC2_CC19IC	xx'004C _H	13 _H / 19 _D
CAPCOM Register 20, or USIC0 Request 6	CC2_CC20IC	xx'0050 _H	14 _H / 20 _D
CAPCOM Register 21, or USIC0 Request 7	CC2_CC21IC	xx'0054 _H	15 _H / 21 _D
CAPCOM Register 22, or USIC1 Request 6	CC2_CC22IC	xx'0058 _H	16 _H / 22 _D
CAPCOM Register 23, or USIC1 Request 7	CC2_CC23IC	xx'005C _H	17 _H / 23 _D
CAPCOM Register 24, or ERU Request 0	CC2_CC24IC	xx'0060 _H	18 _H / 24 _D
CAPCOM Register 25, or ERU Request 1	CC2_CC25IC	xx'0064 _H	19 _H / 25 _D
CAPCOM Register 26, or ERU Request 2	CC2_CC26IC	xx'0068 _H	1A _H / 26 _D
CAPCOM Register 27, or ERU Request 3	CC2_CC27IC	xx'006C _H	1B _H / 27 _D
CAPCOM Register 28, or USIC2 Request 6	CC2_CC28IC	xx'0070 _H	1C _H / 28 _D
CAPCOM Register 29, or USIC2 Request 7	CC2_CC29IC	xx'0074 _H	1D _H / 29 _D
CAPCOM Register 30	CC2_CC30IC	xx'0078 _H	1E _H / 30 _D
CAPCOM Register 31	CC2_CC31IC	xx'007C _H	1F _H / 31 _D
GPT1 Timer 2	GPT12E_T2IC	xx'0080 _H	20 _H / 32 _D
GPT1 Timer 3	GPT12E_T3IC	xx'0084 _H	21 _H / 33 _D
GPT1 Timer 4	GPT12E_T4IC	xx'0088 _H	22 _H / 34 _D

Table 6 XE167 Interrupt Nodes (cont'd)

Source of Interrupt or PEC Service Request	Control Register	Vector Location ¹⁾	Trap Number
GPT2 Timer 5	GPT12E_T5IC	xx'008C _H	23 _H / 35 _D
GPT2 Timer 6	GPT12E_T6IC	xx'0090 _H	24 _H / 36 _D
GPT2 CAPREL Register	GPT12E_CRIC	xx'0094 _H	25 _H / 37 _D
CAPCOM Timer 7	CC2_T7IC	xx'0098 _H	26 _H / 38 _D
CAPCOM Timer 8	CC2_T8IC	xx'009C _H	27 _H / 39 _D
A/D Converter Request 0	ADC_0IC	xx'00A0 _H	28 _H / 40 _D
A/D Converter Request 1	ADC_1IC	xx'00A4 _H	29 _H / 41 _D
A/D Converter Request 2	ADC_2IC	xx'00A8 _H	2A _H / 42 _D
A/D Converter Request 3	ADC_3IC	xx'00AC _H	2B _H / 43 _D
A/D Converter Request 4	ADC_4IC	xx'00B0 _H	2C _H / 44 _D
A/D Converter Request 5	ADC_5IC	xx'00B4 _H	2D _H / 45 _D
A/D Converter Request 6	ADC_6IC	xx'00B8 _H	2E _H / 46 _D
A/D Converter Request 7	ADC_7IC	xx'00BC _H	2F _H / 47 _D
CCU60 Request 0	CCU60_0IC	xx'00C0 _H	30 _H / 48 _D
CCU60 Request 1	CCU60_1IC	xx'00C4 _H	31 _H / 49 _D
CCU60 Request 2	CCU60_2IC	xx'00C8 _H	32 _H / 50 _D
CCU60 Request 3	CCU60_3IC	xx'00CC _H	33 _H / 51 _D
CCU61 Request 0	CCU61_0IC	xx'00D0 _H	34 _H / 52 _D
CCU61 Request 1	CCU61_1IC	xx'00D4 _H	35 _H / 53 _D
CCU61 Request 2	CCU61_2IC	xx'00D8 _H	36 _H / 54 _D
CCU61 Request 3	CCU61_3IC	xx'00DC _H	37 _H / 55 _D
CCU62 Request 0	CCU62_0IC	xx'00E0 _H	38 _H / 56 _D
CCU62 Request 1	CCU62_1IC	xx'00E4 _H	39 _H / 57 _D
CCU62 Request 2	CCU62_2IC	xx'00E8 _H	3A _H / 58 _D
CCU62 Request 3	CCU62_3IC	xx'00EC _H	3B _H / 59 _D
CCU63 Request 0	CCU63_0IC	xx'00F0 _H	3C _H / 60 _D
CCU63 Request 1	CCU63_1IC	xx'00F4 _H	3D _H / 61 _D
CCU63 Request 2	CCU63_2IC	xx'00F8 _H	3E _H / 62 _D
CCU63 Request 3	CCU63_3IC	xx'00FC _H	3F _H / 63 _D
CAN Request 0	CAN_0IC	xx'0100 _H	40 _H / 64 _D

Functional Description

Table 6 XE167 Interrupt Nodes (cont'd)

Source of Interrupt or PEC Service Request	Control Register	Vector Location¹⁾	Trap Number
CAN Request 1	CAN_1IC	xx'0104 _H	41 _H / 65 _D
CAN Request 2	CAN_2IC	xx'0108 _H	42 _H / 66 _D
CAN Request 3	CAN_3IC	xx'010C _H	43 _H / 67 _D
CAN Request 4	CAN_4IC	xx'0110 _H	44 _H / 68 _D
CAN Request 5	CAN_5IC	xx'0114 _H	45 _H / 69 _D
CAN Request 6	CAN_6IC	xx'0118 _H	46 _H / 70 _D
CAN Request 7	CAN_7IC	xx'011C _H	47 _H / 71 _D
CAN Request 8	CAN_8IC	xx'0120 _H	48 _H / 72 _D
CAN Request 9	CAN_9IC	xx'0124 _H	49 _H / 73 _D
CAN Request 10	CAN_10IC	xx'0128 _H	4A _H / 74 _D
CAN Request 11	CAN_11IC	xx'012C _H	4B _H / 75 _D
CAN Request 12	CAN_12IC	xx'0130 _H	4C _H / 76 _D
CAN Request 13	CAN_13IC	xx'0134 _H	4D _H / 77 _D
CAN Request 14	CAN_14IC	xx'0138 _H	4E _H / 78 _D
CAN Request 15	CAN_15IC	xx'013C _H	4F _H / 79 _D
USIC0 Cannel 0, Request 0	U0C0_0IC	xx'0140 _H	50 _H / 80 _D
USIC0 Cannel 0, Request 1	U0C0_1IC	xx'0144 _H	51 _H / 81 _D
USIC0 Cannel 0, Request 2	U0C0_2IC	xx'0148 _H	52 _H / 82 _D
USIC0 Cannel 1, Request 0	U0C1_0IC	xx'014C _H	53 _H / 83 _D
USIC0 Cannel 1, Request 1	U0C1_1IC	xx'0150 _H	54 _H / 84 _D
USIC0 Cannel 1, Request 2	U0C1_2IC	xx'0154 _H	55 _H / 85 _D
USIC1 Cannel 0, Request 0	U1C0_0IC	xx'0158 _H	56 _H / 86 _D
USIC1 Cannel 0, Request 1	U1C0_1IC	xx'015C _H	57 _H / 87 _D
USIC1 Cannel 0, Request 2	U1C0_2IC	xx'0160 _H	58 _H / 88 _D
USIC1 Cannel 1, Request 0	U1C1_0IC	xx'0164 _H	59 _H / 89 _D
USIC1 Cannel 1, Request 1	U1C1_1IC	xx'0168 _H	5A _H / 90 _D
USIC1 Cannel 1, Request 2	U1C1_2IC	xx'016C _H	5B _H / 91 _D
USIC2 Cannel 0, Request 0	U2C0_0IC	xx'0170 _H	5C _H / 92 _D
USIC2 Cannel 0, Request 1	U2C0_1IC	xx'0174 _H	5D _H / 93 _D
USIC2 Cannel 0, Request 2	U2C0_2IC	xx'0178 _H	5E _H / 94 _D

Table 6 XE167 Interrupt Nodes (cont'd)

Source of Interrupt or PEC Service Request	Control Register	Vector Location¹⁾	Trap Number
USIC2 Cannel 1, Request 0	U2C1_0IC	xx'017C _H	5F _H / 95 _D
USIC2 Cannel 1, Request 1	U2C1_1IC	xx'0180 _H	60 _H / 96 _D
USIC2 Cannel 1, Request 2	U2C1_2IC	xx'0184 _H	61 _H / 97 _D
Unassigned node	–	xx'0188 _H	62 _H / 98 _D
Unassigned node	–	xx'018C _H	63 _H / 99 _D
Unassigned node	–	xx'0190 _H	64 _H / 100 _D
Unassigned node	–	xx'0194 _H	65 _H / 101 _D
Unassigned node	–	xx'0198 _H	66 _H / 102 _D
Unassigned node	–	xx'019C _H	67 _H / 103 _D
Unassigned node	–	xx'01A0 _H	68 _H / 104 _D
Unassigned node	–	xx'01A4 _H	69 _H / 105 _D
Unassigned node	–	xx'01A8 _H	6A _H / 106 _D
SCU Request 1	SCU_1IC	xx'01AC _H	6B _H / 107 _D
SCU Request 0	SCU_0IC	xx'01B0 _H	6C _H / 108 _D
Program Flash Modules	PFM_IC	xx'01B4 _H	6D _H / 109 _D
RTC	RTC_IC	xx'01B8 _H	6E _H / 110 _D
End of PEC Subchannel	EOPIC	xx'01BC _H	6F _H / 111 _D

1) Register VECSEG defines the segment where the vector table is located.
 Bitfield VECSC in register CPUCON1 defines the distance between two adjacent vectors. This table represents the default setting with a distance of 4 (two words) between two vectors.

Functional Description

The XE167 includes an excellent mechanism to identify and process exceptions or error conditions that arise during run-time, the so-called 'Hardware Traps'. A hardware trap causes an immediate non-maskable system reaction similar to a standard interrupt service (branching to a dedicated vector table location). The occurrence of a hardware trap is also indicated by a single bit in the trap flag register (TFR). Unless another higher-priority trap service is in progress, a hardware trap will interrupt any ongoing program execution. In turn, hardware trap services can normally not be interrupted by standard or PEC interrupts.

Table 7 shows all possible exceptions or error conditions that can arise during runtime:

Table 7 Trap Summary

Exception Condition	Trap Flag	Trap Vector	Vector Location¹⁾	Trap Number	Trap Priority
Reset Functions	–	RESET	xx'0000 _H	00 _H	III
Class A Hardware Traps:					
• System Request 0	SR0	SR0TRAP	xx'0008 _H	02 _H	II
• Stack Overflow	STKOF	STOTRAP	xx'0010 _H	04 _H	II
• Stack Underflow	STKUF	STUTRAP	xx'0018 _H	06 _H	II
• Software Break	SOFTBRK	SBRKTRAP	xx'0020 _H	08 _H	II
Class B Hardware Traps:					
• System Request 1	SR1	BTRAP	xx'0028 _H	0A _H	I
• Undefined Opcode	UNDOPC	BTRAP	xx'0028 _H	0A _H	I
• Memory Access Error	ACER	BTRAP	xx'0028 _H	0A _H	I
• Protected Instruction Fault	PRTFLT	BTRAP	xx'0028 _H	0A _H	I
• Illegal Word Operand Access	ILLOPA	BTRAP	xx'0028 _H	0A _H	I
Reserved	–	–	[2C _H - 3C _H]	[0B _H - 0F _H]	–
Software Traps:	–	–	Any	Any	Current CPU Priority
• TRAP Instruction			[xx'0000 _H - xx'01FC _H] in steps of 4 _H	[00 _H - 7F _H]	

1) Register VECSEG defines the segment where the vector table is located to. Bitfield VECSC in register CPUCON1 defines the distance between two adjacent vectors. This table represents the default setting, with a distance of 4 (two words) between two vectors.

3.5 On-Chip Debug Support (OCDS)

The On-Chip Debug Support system built into the XE167 provides a broad range of debug and emulation features. User software running on the XE167 can be debugged within the target system environment.

The OCDS is controlled by an external debugging device via the debug interface. This consists of the JTAG port conforming to IEEE-1149. The debug interface can be completed with an optional break interface.

The debugger controls the OCDS with a set of dedicated registers accessible via the debug interface (JTAG). In addition the OCDS system can be controlled by the CPU, e.g. by a monitor program. An injection interface allows the execution of OCDS-generated instructions by the CPU.

Multiple breakpoints can be triggered by on-chip hardware, by software, or by an external trigger input. Single stepping is supported, as is the injection of arbitrary instructions and read/write access to the complete internal address space. A breakpoint trigger can be answered with a CPU halt, a monitor call, a data transfer, or/and the activation of an external signal.

Tracing data can be obtained via the debug interface, or via the external bus interface for increased performance.

The JTAG interface uses four interface signals, to communicate with external circuitry. The debug interface can be amended with two optional break lines.

3.6 Capture/Compare Unit (CAPCOM2)

The CAPCOM2 unit supports generation and control of timing sequences on up to 16 channels with a maximum resolution of one system clock cycle (eight cycles in staggered mode). The CAPCOM2 unit is typically used to handle high-speed I/O tasks such as pulse and waveform generation, pulse width modulation (PWM), digital to analog (D/A) conversion, software timing, or time recording with respect to external events.

Two 16-bit timers (T7/T8) with reload registers provide two independent time bases for the capture/compare register array.

The input clock for the timers is programmable to a number of prescaled values of the internal system clock. It may also be derived from an overflow/underflow of timer T6 in module GPT2. This provides a wide range for the timer period and resolution while allowing precise adjustments for application-specific requirements. An external count input for CAPCOM2 timer T7 allows event scheduling for the capture/compare registers with respect to external events.

The capture/compare register array contains 16 dual purpose capture/compare registers. Each may be individually allocated to either CAPCOM2 timer T7 or T8 and programmed for a capture or compare function.

Each register of the CAPCOM2 module has one port pin associated with it. This serves as an input pin to trigger the capture function or as an output pin to indicate the occurrence of a compare event.

Table 8 Compare Modes (CAPCOM2)

Compare Modes	Function
Mode 0	Interrupt-only compare mode; Several compare interrupts per timer period are possible
Mode 1	Pin toggles on each compare match; Several compare events per timer period are possible
Mode 2	Interrupt-only compare mode; Only one compare interrupt per timer period is generated
Mode 3	Pin set '1' on match; pin reset '0' on compare timer overflow; Only one compare event per timer period is generated
Double Register Mode	Two registers operate on one pin; Pin toggles on each compare match; Several compare events per timer period are possible
Single Event Mode	Generates single edges or pulses; Can be used with any compare mode

Functional Description

When a capture/compare register has been selected for capture mode, the current contents of the allocated timer will be latched ('captured') into the capture/compare register in response to an external event at the port pin associated with this register. In addition, a specific interrupt request for this capture/compare register is generated. Either a positive, a negative, or both a positive and a negative external signal transition at the pin can be selected as the triggering event.

The contents of all registers selected for one of the five compare modes are continuously compared with the contents of the allocated timers.

When a match occurs between the timer value and the value in a capture/compare register, specific actions will be taken based on the compare mode selected.

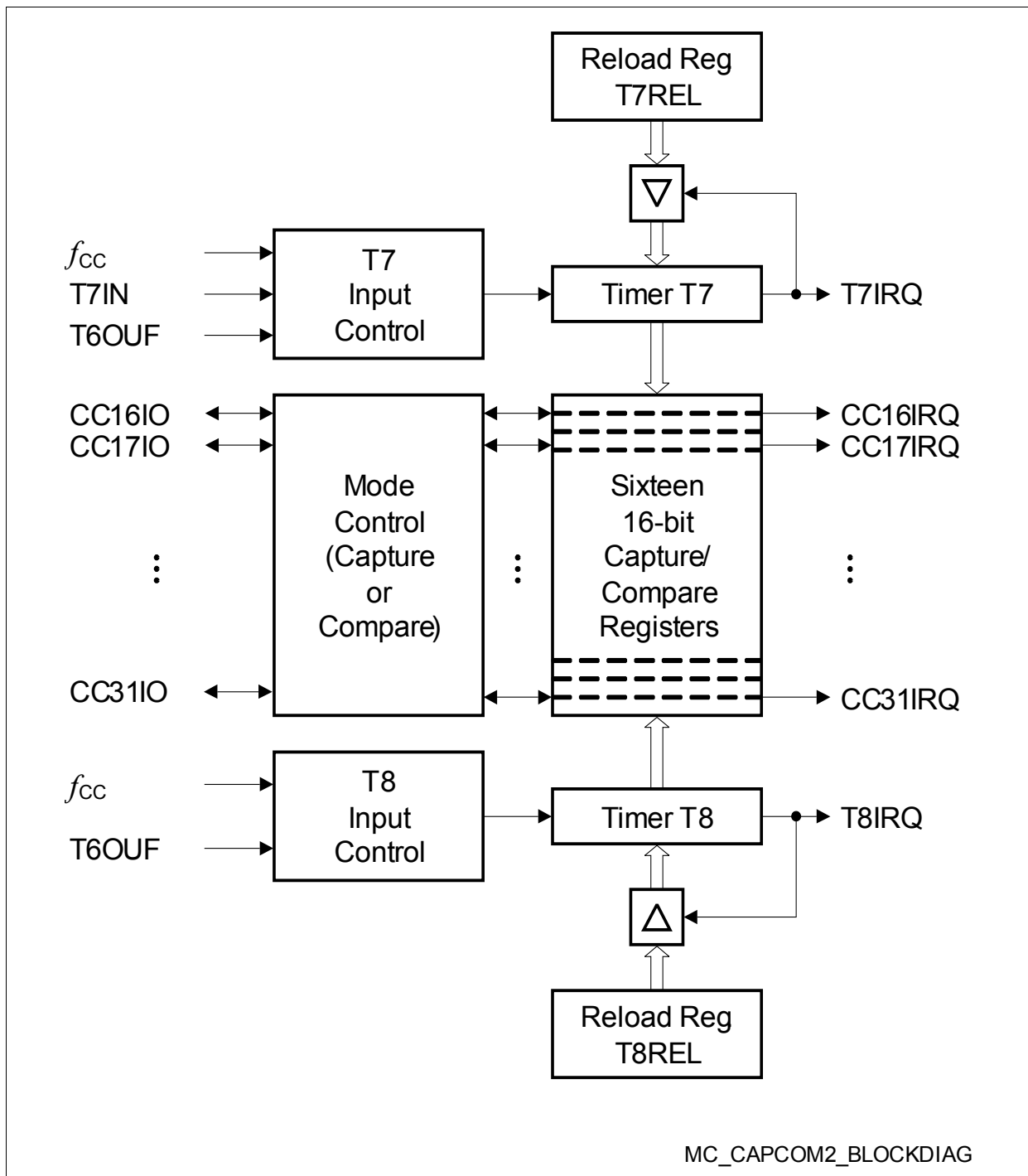

Figure 5 CAPCOM2 Unit Block Diagram

3.7 Capture/Compare Units CCU6x

The XE167 features up to four CCU6 units (CCU60, CCU61, CCU62, CCU63).

The CCU6 is a high-resolution capture and compare unit with application-specific modes. It provides inputs to start the timers synchronously, an important feature in devices with several CCU6 modules.

The module provides two independent timers (T12, T13), that can be used for PWM generation, especially for AC motor control. Additionally, special control modes for block commutation and multi-phase machines are supported.

Timer 12 Features

- Three capture/compare channels, where each channel can be used either as a capture or as a compare channel.
- Supports generation of a three-phase PWM (six outputs, individual signals for high-side and low-side switches)
- 16-bit resolution, maximum count frequency = peripheral clock
- Dead-time control for each channel to avoid short circuits in the power stage
- Concurrent update of the required T12/13 registers
- Center-aligned and edge-aligned PWM can be generated
- Single-shot mode supported
- Many interrupt request sources
- Hysteresis-like control mode
- Automatic start on a HW event (T12HR, for synchronization purposes)

Timer 13 Features

- One independent compare channel with one output
- 16-bit resolution, maximum count frequency = peripheral clock
- Can be synchronized to T12
- Interrupt generation at period match and compare match
- Single-shot mode supported
- Automatic start on a HW event (T13HR, for synchronization purposes)

Additional Features

- Block commutation for brushless DC drives implemented
- Position detection via Hall sensor pattern
- Automatic rotational speed measurement for block commutation
- Integrated error handling
- Fast emergency stop without CPU load via external signal ($\overline{\text{CTRAP}}$)
- Control modes for multi-channel AC drives
- Output levels can be selected and adapted to the power stage

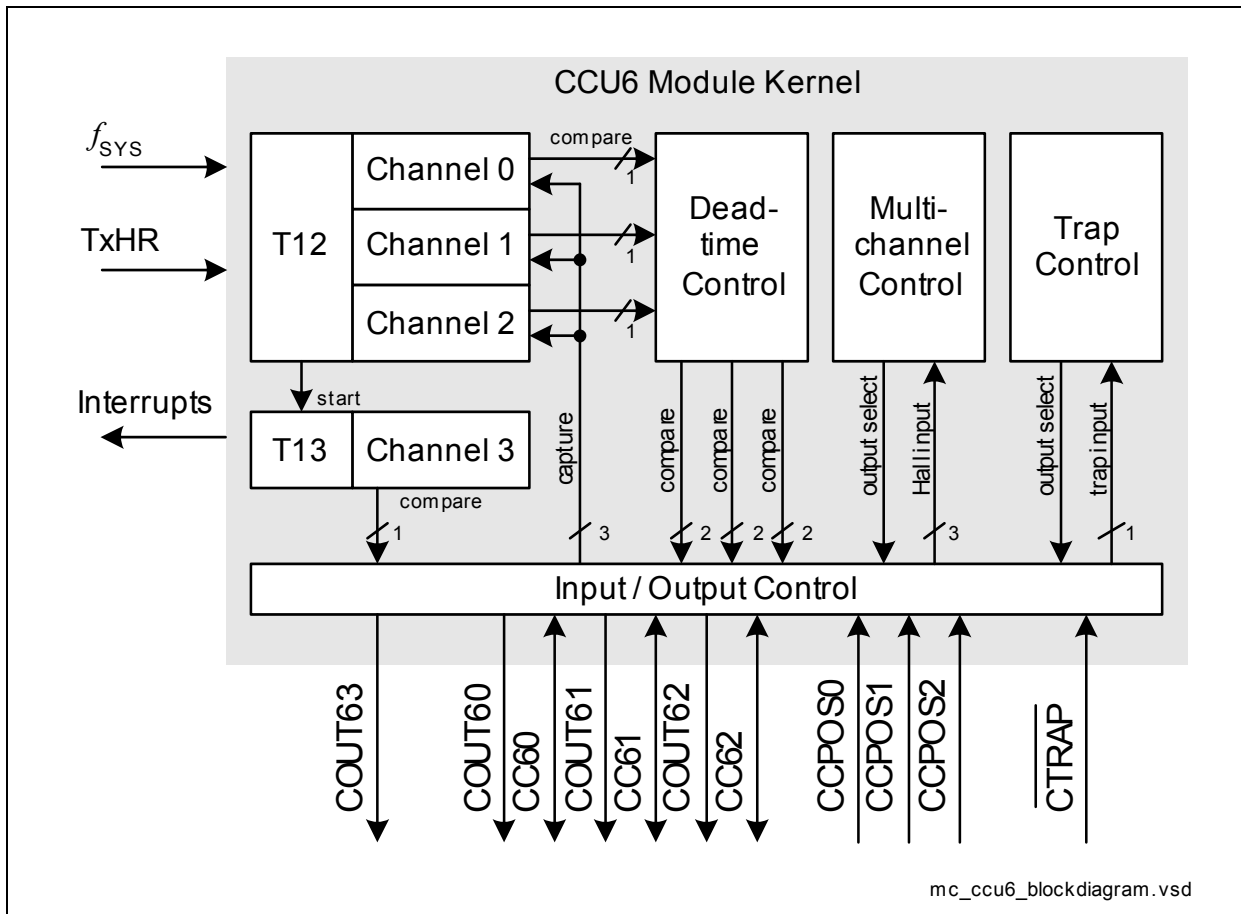

Figure 6 CCU6 Block Diagram

Timer T12 can work in capture and/or compare mode for its three channels. The modes can also be combined. Timer T13 can work in compare mode only. The multi-channel control unit generates output patterns that can be modulated by timer T12 and/or timer T13. The modulation sources can be selected and combined for signal modulation.

3.8 General Purpose Timer (GPT12E) Unit

The GPT12E unit is a very flexible multifunctional timer/counter structure which can be used for many different timing tasks such as event timing and counting, pulse width and duty cycle measurements, pulse generation, or pulse multiplication.

The GPT12E unit incorporates five 16-bit timers organized in two separate modules, GPT1 and GPT2. Each timer in each module may either operate independently in a number of different modes or be concatenated with another timer of the same module.

Each of the three timers T2, T3, T4 of **module GPT1** can be configured individually for one of four basic modes of operation: Timer, Gated Timer, Counter, and Incremental Interface Mode. In Timer Mode, the input clock for a timer is derived from the system clock and divided by a programmable prescaler. Counter Mode allows timer clocking in reference to external events.

Pulse width or duty cycle measurement is supported in Gated Timer Mode, where the operation of a timer is controlled by the 'gate' level on an external input pin. For these purposes each timer has one associated port pin (TxIN) which serves as a gate or clock input. The maximum resolution of the timers in module GPT1 is 4 system clock cycles.

The counting direction (up/down) for each timer can be programmed by software or altered dynamically by an external signal on a port pin (TxEUD), e.g. to facilitate position tracking.

In Incremental Interface Mode the GPT1 timers can be directly connected to the incremental position sensor signals A and B through their respective inputs TxIN and TxEUD. Direction and counting signals are internally derived from these two input signals, so that the contents of the respective timer Tx corresponds to the sensor position. The third position sensor signal TOP0 can be connected to an interrupt input.

Timer T3 has an output toggle latch (T3OTL) which changes its state on each timer overflow/underflow. The state of this latch may be output on pin T3OUT e.g. for time out monitoring of external hardware components. It may also be used internally to clock timers T2 and T4 for measuring long time periods with high resolution.

In addition to the basic operating modes, T2 and T4 may be configured as reload or capture register for timer T3. A timer used as capture or reload register is stopped. The contents of timer T3 is captured into T2 or T4 in response to a signal at the associated input pin (TxIN). Timer T3 is reloaded with the contents of T2 or T4, triggered either by an external signal or a selectable state transition of its toggle latch T3OTL. When both T2 and T4 are configured to alternately reload T3 on opposite state transitions of T3OTL with the low and high times of a PWM signal, this signal can be continuously generated without software intervention.

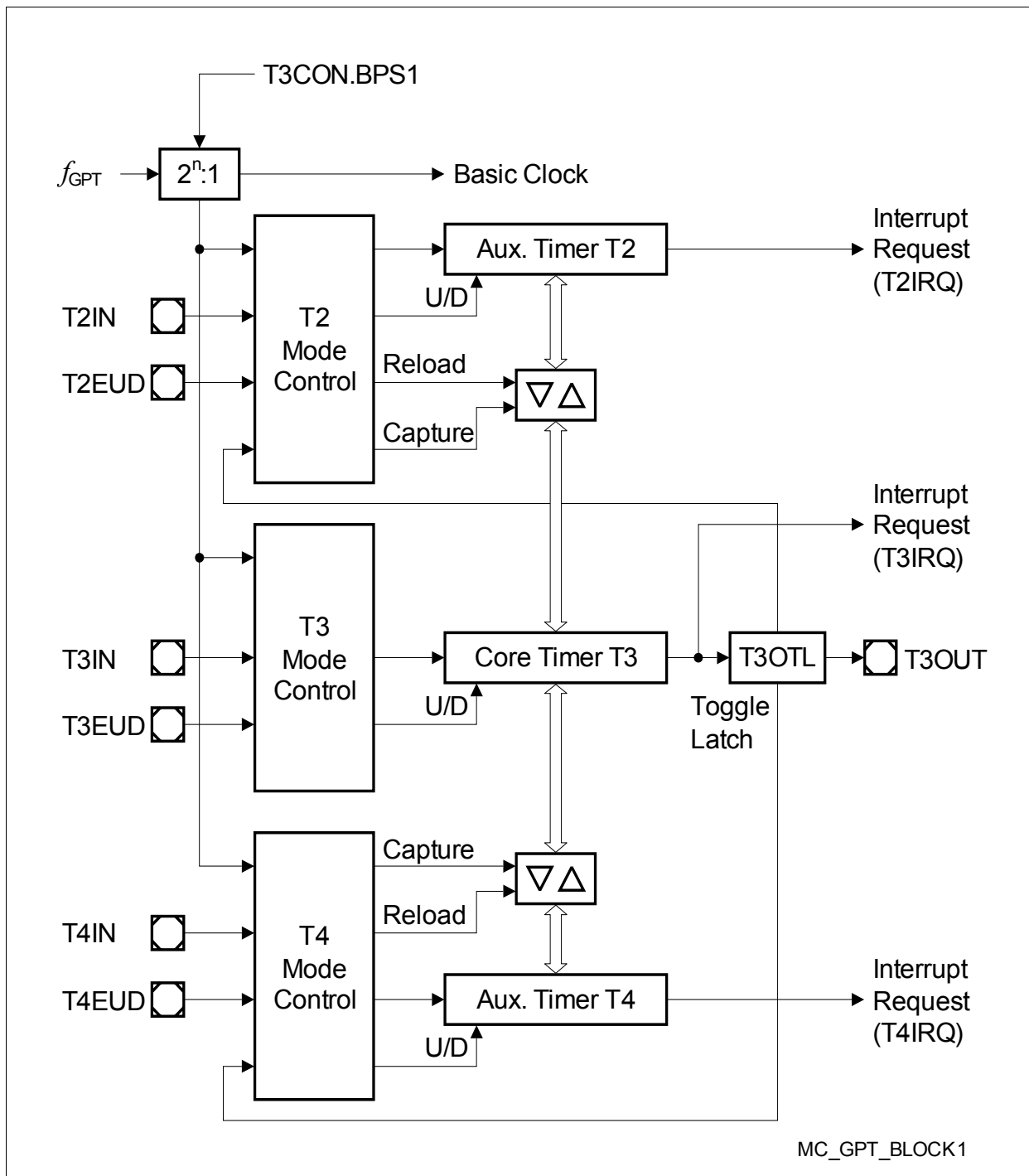

Figure 7 Block Diagram of GPT1

Functional Description

With its maximum resolution of 2 system clock cycles, the **GPT2 module** provides precise event control and time measurement. It includes two timers (T5, T6) and a capture/reload register (CAPREL). Both timers can be clocked with an input clock which is derived from the CPU clock via a programmable prescaler or with external signals. The counting direction (up/down) for each timer can be programmed by software or altered dynamically with an external signal on a port pin (TxEUD). Concatenation of the timers is supported with the output toggle latch (T6OTL) of timer T6, which changes its state on each timer overflow/underflow.

The state of this latch may be used to clock timer T5, and/or it may be output on pin T6OUT. The overflows/underflows of timer T6 can also be used to clock the CAPCOM2 timers and to initiate a reload from the CAPREL register.

The CAPREL register can capture the contents of timer T5 based on an external signal transition on the corresponding port pin (CAPIN); timer T5 may optionally be cleared after the capture procedure. This allows the XE167 to measure absolute time differences or to perform pulse multiplication without software overhead.

The capture trigger (timer T5 to CAPREL) can also be generated upon transitions of GPT1 timer T3 inputs T3IN and/or T3EUD. This is especially advantageous when T3 operates in Incremental Interface Mode.

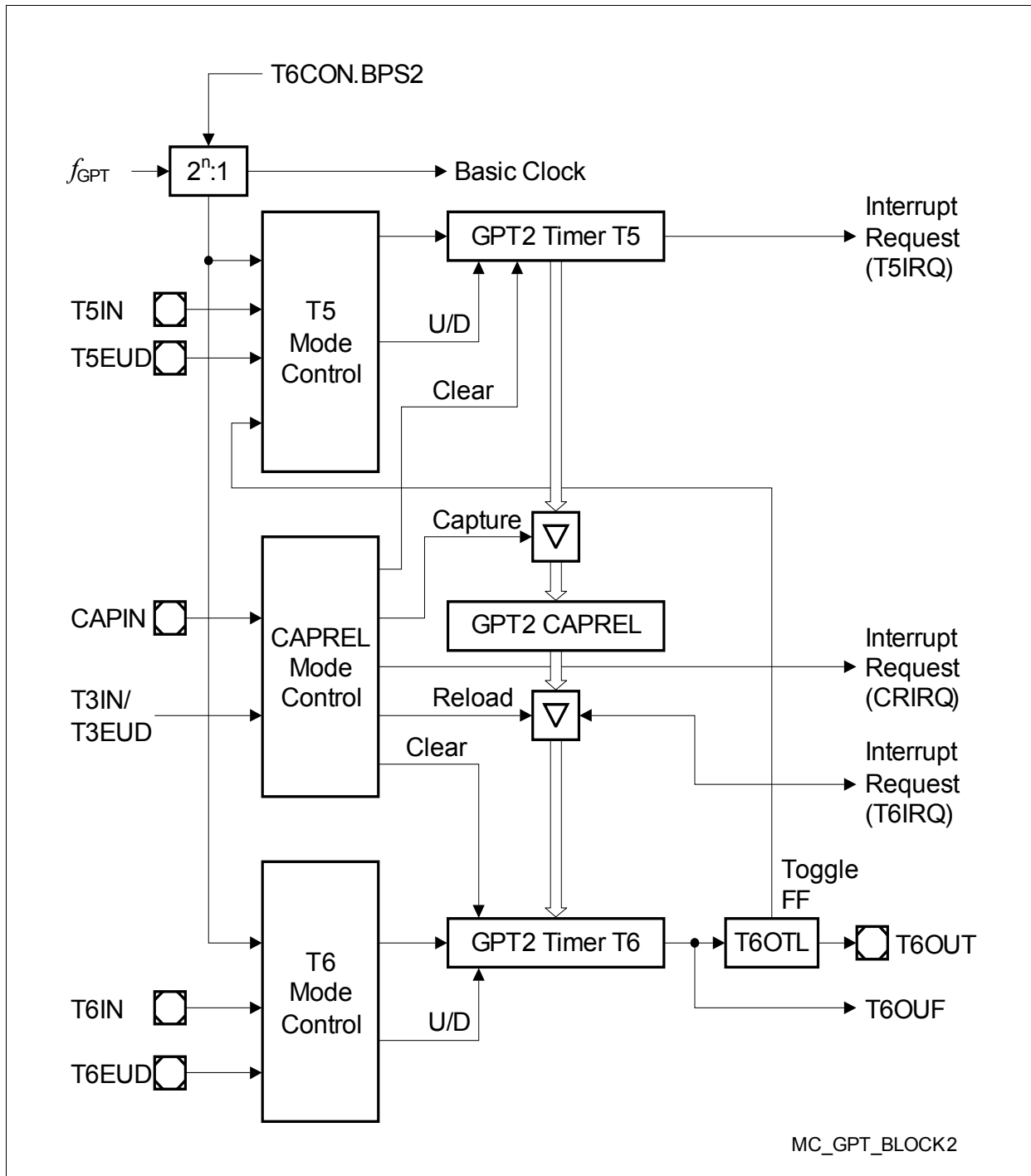

Figure 8 Block Diagram of GPT2

3.9 Real Time Clock

The Real Time Clock (RTC) module of the XE167 can be clocked with a clock signal selected from internal sources or external sources (pins).

The RTC basically consists of a chain of divider blocks:

- Selectable 32:1 and 8:1 dividers (on - off)
- The reloadable 16-bit timer T14
- The 32-bit RTC timer block (accessible via registers RTCH and RTCL) consisting of:
 - a reloadable 10-bit timer
 - a reloadable 6-bit timer
 - a reloadable 6-bit timer
 - a reloadable 10-bit timer

All timers count up. Each timer can generate an interrupt request. All requests are combined to a common node request.

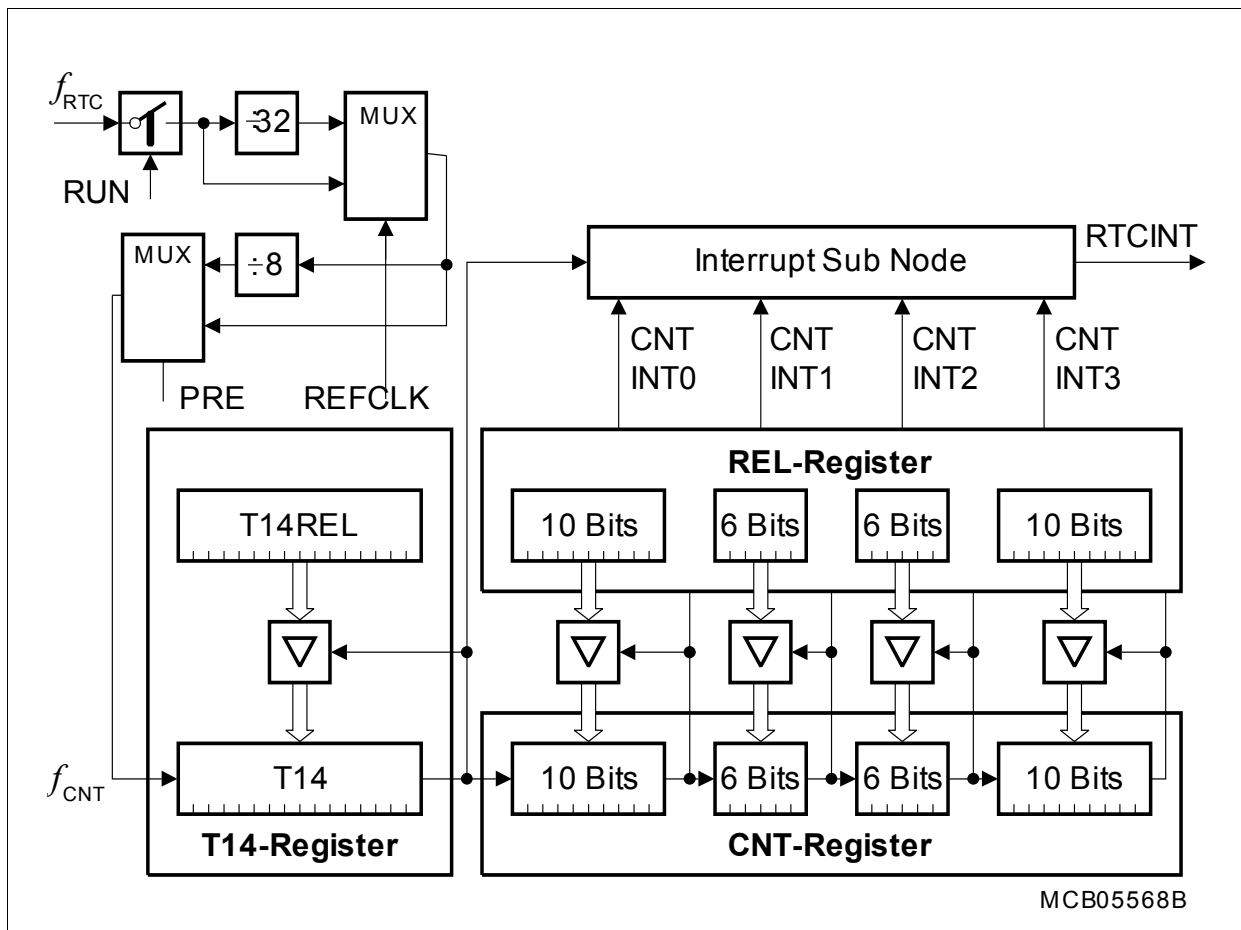

Figure 9 RTC Block Diagram

Note: The registers associated with the RTC are only affected by a power reset.

Functional Description

The RTC module can be used for different purposes:

- System clock to determine the current time and date
- Cyclic time-based interrupt, to provide a system time tick independent of CPU frequency and other resources
- 48-bit timer for long-term measurements
- Alarm interrupt at a defined time

3.10 A/D Converters

For analog signal measurement, up to two 10-bit A/D converters (ADC0, ADC1) with 16 + 8 multiplexed input channels and a sample and hold circuit have been integrated on-chip. They use the successive approximation method. The sample time (to charge the capacitors) and the conversion time are programmable so that they can be adjusted to the external circuit. The A/D converters can also operate in 8-bit conversion mode, further reducing the conversion time.

Several independent conversion result registers, selectable interrupt requests, and highly flexible conversion sequences provide a high degree of programmability to meet the application requirements. Both modules can be synchronized to allow parallel sampling of two input channels.

For applications that require more analog input channels, external analog multiplexers can be controlled automatically.

For applications that require fewer analog input channels, the remaining channel inputs can be used as digital input port pins.

The A/D converters of the XE167 support two types of request sources which can be triggered by several internal and external events.

- Parallel requests are activated at the same time and then executed in a predefined sequence.
- Queued requests are executed in a user-defined sequence.

In addition, the conversion of a specific channel can be inserted into a running sequence without disturbing that sequence. All requests are arbitrated according to the priority level assigned to them.

Data reduction features, such as limit checking or result accumulation, reduce the number of required CPU access operations allowing the precise evaluation of analog inputs (high conversion rate) even at a low CPU speed.

The Peripheral Event Controller (PEC) can be used to control the A/D converters or to automatically store conversion results to a table in memory for later evaluation, without requiring the overhead of entering and exiting interrupt routines for each data transfer. Each A/D converter contains eight result registers which can be concatenated to build a result FIFO. Wait-for-read mode can be enabled for each result register to prevent the loss of conversion data.

In order to decouple analog inputs from digital noise and to avoid input trigger noise, those pins used for analog input can be disconnected from the digital input stages under software control. This can be selected for each pin separately with registers P5_DIDIS and P15_DIDIS (Port x Digital Input Disable).

The Auto-Power-Down feature of the A/D converters minimizes the power consumption when no conversion is in progress.

3.11 Universal Serial Interface Channel Modules (USIC)

The XE167 includes up to three USIC modules (USIC0, USIC1, USIC2), each providing two serial communication channels.

The Universal Serial Interface Channel (USIC) module is based on a generic data shift and data storage structure which is identical for all supported serial communication protocols. Each channel supports complete full-duplex operation with a basic data buffer structure (one transmit buffer and two receive buffer stages). In addition, the data handling software can use FIFOs.

The protocol part (generation of shift clock/data/control signals) is independent of the general part and is handled by protocol-specific preprocessors (PPPs).

The USIC's input/output lines are connected to pins by a pin routing unit. The inputs and outputs of each USIC channel can be assigned to different interface pins, providing great flexibility to the application software. All assignments can be made during runtime.

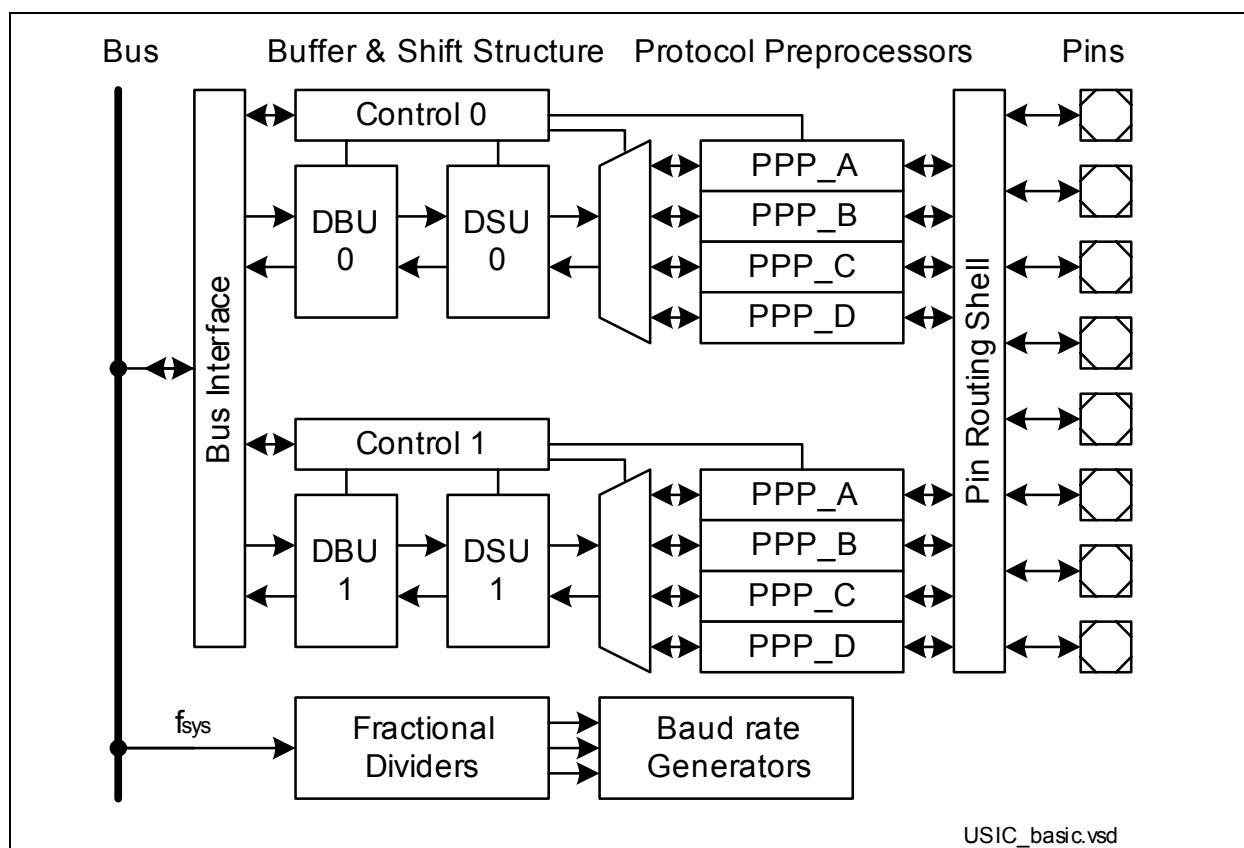

Figure 10 General Structure of a USIC Module

The regular structure of the USIC module brings the following advantages:

- Higher flexibility through configuration with same look-and-feel for data management
- Reduced complexity for low-level drivers serving different protocols
- Wide range of protocols with improved performances (baud rate, buffer handling)

Target Protocols

Each USIC channel can receive and transmit data frames with a selectable data word width from 1 to 16 bits in each of the following protocols:

- **UART** (asynchronous serial channel)
 - maximum baud rate: $f_{SYS} / 4$
 - data frame length programmable from 1 to 63 bits
 - MSB or LSB first
- **LIN** Support (Local Interconnect Network)
 - maximum baud rate: $f_{SYS} / 16$
 - checksum generation under software control
 - baud rate detection possible by built-in capture event of baud rate generator
- **SSC/SPI/QSPI** (synchronous serial channel with or without data buffer)
 - maximum baud rate in slave mode: f_{SYS}
 - maximum baud rate in master mode: $f_{SYS} / 2$, limited by loop delay
 - number of data bits programmable from 1 to 63, more with explicit stop condition
 - MSB or LSB first
 - optional control of slave select signals
- **IIC** (Inter-IC Bus)
 - supports baud rates of 100 kbit/s and 400 kbit/s
- **IIS** (Inter-IC Sound Bus)
 - maximum baud rate: $f_{SYS} / 2$ for transmitter, f_{SYS} for receiver

Note: Depending on the selected functions (such as digital filters, input synchronization stages, sample point adjustment, etc.), the maximum achievable baud rate can be limited. Please note that there may be additional delays, such as internal or external propagation delays and driver delays (e.g. for collision detection in UART mode, for IIC, etc.).

3.12 MultiCAN Module

The MultiCAN module contains up to five independently operating CAN nodes with Full-CAN functionality which are able to exchange Data and Remote Frames using a gateway function. Transmission and reception of CAN frames is handled in accordance with CAN specification V2.0 B (active). Each CAN node can receive and transmit standard frames with 11-bit identifiers as well as extended frames with 29-bit identifiers.

All CAN nodes share a common set of 128 message objects. Each message object can be individually allocated to one of the CAN nodes. Besides serving as a storage container for incoming and outgoing frames, message objects can be combined to build gateways between the CAN nodes or to set up a FIFO buffer.

The message objects are organized in double-chained linked lists, where each CAN node has its own list of message objects. A CAN node stores frames only into message objects that are allocated to its own message object list and it transmits only messages belonging to this message object list. A powerful, command-driven list controller performs all message object list operations.

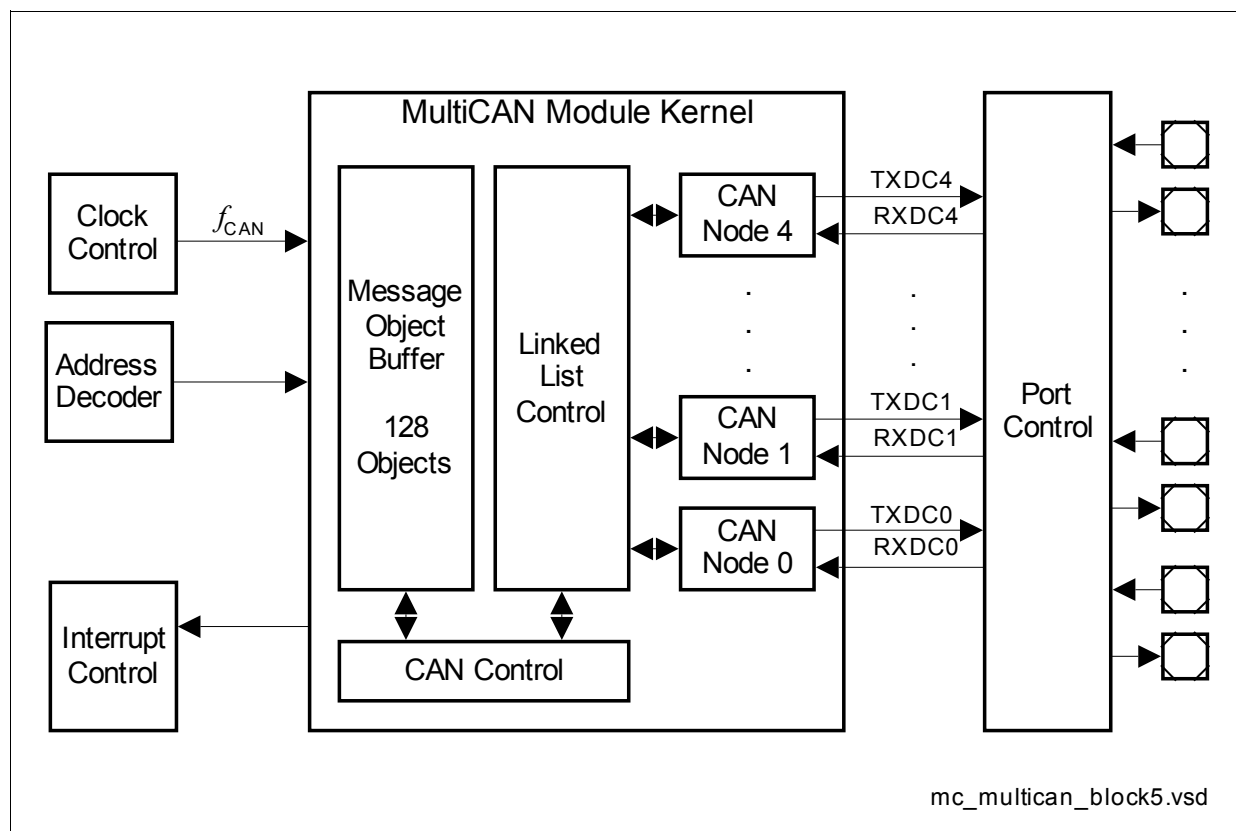

Figure 11 Block Diagram of MultiCAN Module

MultiCAN Features

- CAN functionality conforming to CAN specification V2.0 B active for each CAN node (compliant to ISO 11898)
- Up to five independent CAN nodes
- 128 independent message objects (shared by the CAN nodes)
- Dedicated control registers for each CAN node
- Data transfer rate up to 1 Mbit/s, individually programmable for each node
- Flexible and powerful message transfer control and error handling capabilities
- Full-CAN functionality for message objects:
 - Can be assigned to one of the CAN nodes
 - Configurable as transmit or receive objects, or as message buffer FIFO
 - Handle 11-bit or 29-bit identifiers with programmable acceptance mask for filtering
 - Remote Monitoring Mode, and frame counter for monitoring
- Automatic Gateway Mode support
- 16 individually programmable interrupt nodes
- Analyzer mode for CAN bus monitoring

3.13 Watchdog Timer

The Watchdog Timer is one of the fail-safe mechanisms which have been implemented to prevent the controller from malfunctioning for longer periods of time.

The Watchdog Timer is always enabled after an application reset of the chip. It can be disabled and enabled at any time by executing the instructions DISWDT and ENWDT respectively. The software has to service the Watchdog Timer before it overflows. If this is not the case because of a hardware or software failure, the Watchdog Timer overflows, generating a prewarning interrupt and then a reset request.

The Watchdog Timer is a 16-bit timer clocked with the system clock divided by 16,384 or 256. The Watchdog Timer register is set to a prespecified reload value (stored in WDTREL) in order to allow further variation of the monitored time interval. Each time it is serviced by the application software, the Watchdog Timer is reloaded and the prescaler is cleared.

Time intervals between 3.2 μ s and 13.4 s can be monitored (@ 80 MHz).

The default Watchdog Timer interval after power-up is 6.5 ms (@ 10 MHz).

3.14 Clock Generation

The Clock Generation Unit can generate the system clock signal f_{SYS} for the XE167 from a number of external or internal clock sources:

- External clock signals with pad or core voltage levels
- External crystal using the on-chip oscillator
- On-chip clock source for operation without crystal
- Wake-up clock (ultra-low-power) to further reduce power consumption

The programmable on-chip PLL with multiple prescalers generates a clock signal for maximum system performance from standard crystals or from the on-chip clock source. See also [Section 4.6.2](#).

The Oscillator Watchdog (OWD) generates an interrupt if the crystal oscillator frequency falls below a certain limit or stops completely. In this case, the system can be supplied with an emergency clock to enable operation even after an external clock failure.

All available clock signals can be output on one of two selectable pins.

3.15 Parallel Ports

The XE167 provides up to 118 I/O lines which are organized into 11 input/output ports and 2 input ports. All port lines are bit-addressable, and all input/output lines can be individually (bit-wise) configured via port control registers. This configuration selects the direction (input/output), push/pull or open-drain operation, activation of pull devices, and edge characteristics (shape) and driver characteristics (output current) of the port drivers. The I/O ports are true bidirectional ports which are switched to high impedance state when configured as inputs. During the internal reset, all port pins are configured as inputs without pull devices active.

All port lines have alternate input or output functions associated with them. These alternate functions can be programmed to be assigned to various port pins to support the best utilization for a given application. For this reason, certain functions appear several times in [Table 9](#).

All port lines that are not used for alternate functions may be used as general purpose I/O lines.

Table 9 Summary of the XE167's Parallel Ports

Port	Width	Alternate Functions
Port 0	8	Address lines, Serial interface lines of USIC1, CAN0, and CAN1, Input/Output lines for CCU61
Port 1	8	Address lines, Serial interface lines of USIC1 and USIC2, Input/Output lines for CCU62, OCDS control, interrupts
Port 2	13	Address and/or data lines, bus control, Serial interface lines of USIC0, CAN0, and CAN1, Input/Output lines for CCU60, CCU63, and CAPCOM2, Timer control signals, JTAG, interrupts, system clock output
Port 3	8	Bus arbitration signals, Serial interface lines of USIC0, USIC2, CAN3, and CAN4
Port 4	8	Chip select signals, Serial interface lines of CAN2, Input/Output lines for CAPCOM2, Timer control signals

Table 9 **Summary of the XE167's Parallel Ports (cont'd)**

Port	Width	Alternate Functions
Port 5	16	Analog input channels to ADC0, Input/Output lines for CCU6x, Timer control signals, JTAG, OCDS control, interrupts
Port 6	4	ADC control lines, Serial interface lines of USIC1, Timer control signals, OCDS control
Port 7	5	ADC control lines, Serial interface lines of USIC0 and CAN4, Input/Output lines for CCU62, Timer control signals, JTAG, OCDS control, system clock output
Port 8	7	Input/Output lines for CCU60, JTAG, OCDS control
Port 9	8	Serial interface lines of USIC2, Input/Output lines for CCU60 and CCU63, OCDS control
Port 10	16	Address and/or data lines, bus control, Serial interface lines of USIC0, USIC1, CAN2, CAN3, and CAN4, Input/Output lines for CCU60, JTAG, OCDS control
Port 11	6	Input/Output lines for CCU63
Port 15	8	Analog input channels to ADC1, Timer control signals

3.16 Instruction Set Summary

Table 10 lists the instructions of the XE167.

The addressing modes that can be used with a specific instruction, the function of the instructions, parameters for conditional execution of instructions, and the opcodes for each instruction can be found in the “**Instruction Set Manual**”.

This document also provides a detailed description of each instruction.

Table 10 Instruction Set Summary

Mnemonic	Description	Bytes
ADD(B)	Add word (byte) operands	2 / 4
ADDC(B)	Add word (byte) operands with Carry	2 / 4
SUB(B)	Subtract word (byte) operands	2 / 4
SUBC(B)	Subtract word (byte) operands with Carry	2 / 4
MUL(U)	(Un)Signed multiply direct GPR by direct GPR (16- × 16-bit)	2
DIV(U)	(Un)Signed divide register MDL by direct GPR (16-/16-bit)	2
DIVL(U)	(Un)Signed long divide reg. MD by direct GPR (32-/16-bit)	2
CPL(B)	Complement direct word (byte) GPR	2
NEG(B)	Negate direct word (byte) GPR	2
AND(B)	Bitwise AND, (word/byte operands)	2 / 4
OR(B)	Bitwise OR, (word/byte operands)	2 / 4
XOR(B)	Bitwise exclusive OR, (word/byte operands)	2 / 4
BCLR/BSET	Clear/Set direct bit	2
BMOV(N)	Move (negated) direct bit to direct bit	4
BAND/BOR/BXOR	AND/OR/XOR direct bit with direct bit	4
BCMP	Compare direct bit to direct bit	4
BFLDH/BFLDL	Bitwise modify masked high/low byte of bit-addressable direct word memory with immediate data	4
CMP(B)	Compare word (byte) operands	2 / 4
CMPD1/2	Compare word data to GPR and decrement GPR by 1/2	2 / 4
CMPI1/2	Compare word data to GPR and increment GPR by 1/2	2 / 4
PRIOR	Determine number of shift cycles to normalize direct word GPR and store result in direct word GPR	2
SHL/SHR	Shift left/right direct word GPR	2

Table 10 Instruction Set Summary (cont'd)

Mnemonic	Description	Bytes
ROL/ROR	Rotate left/right direct word GPR	2
ASHR	Arithmetic (sign bit) shift right direct word GPR	2
MOV(B)	Move word (byte) data	2 / 4
MOVBS/Z	Move byte operand to word op. with sign/zero extension	2 / 4
JMPA/I/R	Jump absolute/indirect/relative if condition is met	4
JMPS	Jump absolute to a code segment	4
JB(C)	Jump relative if direct bit is set (and clear bit)	4
JNB(S)	Jump relative if direct bit is not set (and set bit)	4
CALLA/I/R	Call absolute/indirect/relative subroutine if condition is met	4
CALLS	Call absolute subroutine in any code segment	4
PCALL	Push direct word register onto system stack and call absolute subroutine	4
TRAP	Call interrupt service routine via immediate trap number	2
PUSH/POP	Push/pop direct word register onto/from system stack	2
SCXT	Push direct word register onto system stack and update register with word operand	4
RET(P)	Return from intra-segment subroutine (and pop direct word register from system stack)	2
RETS	Return from inter-segment subroutine	2
RETI	Return from interrupt service subroutine	2
SBRK	Software Break	2
SRST	Software Reset	4
IDLE	Enter Idle Mode	4
PWRDN	Unused instruction ¹⁾	4
SRVWDT	Service Watchdog Timer	4
DISWDT/ENWDT	Disable/Enable Watchdog Timer	4
EINIT	End-of-Initialization Register Lock	4
ATOMIC	Begin ATOMIC sequence	2
EXTR	Begin EXTENDED Register sequence	2
EXTP(R)	Begin EXTENDED Page (and Register) sequence	2 / 4
EXTS(R)	Begin EXTENDED Segment (and Register) sequence	2 / 4

Table 10 Instruction Set Summary (cont'd)

Mnemonic	Description	Bytes
NOP	Null operation	2
CoMUL/CoMAC	Multiply (and accumulate)	4
CoADD/CoSUB	Add/Subtract	4
Co(A)SHR	(Arithmetic) Shift right	4
CoSHL	Shift left	4
CoLOAD/STORE	Load accumulator/Store MAC register	4
CoCMP	Compare	4
CoMAX/MIN	Maximum/Minimum	4
CoABS/CoRND	Absolute value/Round accumulator	4
CoMOV	Data move	4
CoNEG/NOP	Negate accumulator/Null operation	4

- 1) The Enter Power Down Mode instruction is not used in the XE167, due to the enhanced power control scheme. PWRDN will be correctly decoded, but will trigger no action.

4 Electrical Parameters

The operating range for the XE167 is defined by its electrical parameters. For proper operation the specified limits must be respected during system design.

Note: Typical parameter values refer to room temperature and nominal supply voltage, minimum/maximum parameter values also include conditions of minimum/maximum temperature and minimum/maximum supply voltage. Additional details are described where applicable.

4.1 General Parameters

These parameters are valid for all subsequent descriptions, unless otherwise noted.

Table 11 Absolute Maximum Rating Parameters

Parameter	Symbol	Values			Unit	Note / Test Condition
		Min.	Typ.	Max.		
Storage temperature	T_{ST}	-65	–	150	°C	–
Junction temperature	T_J	-40	–	125	°C	under bias
Voltage on V_{DDI} pins with respect to ground (V_{SS})	V_{DDIM} , V_{DDI1}	-0.5	–	1.65	V	–
Voltage on V_{DDP} pins with respect to ground (V_{SS})	V_{DDPA} , V_{DDPB}	-0.5	–	6.0	V	–
Voltage on any pin with respect to ground (V_{SS})	V_{IN}	-0.5	–	$V_{DDP} + 0.5$	V	$V_{IN} < V_{DDPmax}$
Input current on any pin during overload condition	–	-10	–	10	mA	–
Absolute sum of all input currents during overload condition	–	–	–	100	mA	–
Output current on any pin	I_{OH} , I_{OL}	–	–	30	mA	–

Note: Stresses above the values listed under “Absolute Maximum Ratings” may cause permanent damage to the device. This is a stress rating only. Functional operation of the device at these or any other conditions above those indicated in the operational sections of this specification is not implied. Exposure to absolute maximum rating conditions for an extended time may affect device reliability. During absolute maximum rating overload conditions ($V_{IN} > V_{DDP}$ or $V_{IN} < V_{SS}$) the voltage on V_{DDP} pins with respect to ground (V_{SS}) must not exceed the values defined by the absolute maximum ratings.

Operating Conditions

The following operating conditions must not be exceeded to ensure correct operation of the XE167. All parameters specified in the following sections refer to these operating conditions, unless otherwise noticed.

Table 12 Operating Condition Parameters

Parameter	Symbol	Values			Unit	Note / Test Condition
		Min.	Typ.	Max.		
Digital core supply voltage	V_{DDI}	1.4	–	1.6	V	
Core Supply Voltage Difference	ΔV_{DDI}	-10	–	+10	mV	$V_{DDIM} - V_{DDI1}$ ¹⁾
Digital supply voltage for IO pads and voltage regulators, upper voltage range	V_{DDPA}, V_{DDPB}	4.5	–	5.5	V	2)
Digital supply voltage for IO pads and voltage regulators, lower voltage range	V_{DDPA}, V_{DDPB}	3.0	–	4.5	V	2)
Digital ground voltage	V_{SS}	0	–	0	V	Reference voltage
Overload current	I_{OV}	-5	–	5	mA	Per IO pin ³⁾⁴⁾
		-2	–	5	mA	Per analog input pin ³⁾⁴⁾
Overload positive current coupling factor for analog inputs ⁵⁾	K_{OVA}	–	1.0×10^{-6}	1.0×10^{-4}	–	$I_{OV} > 0$
Overload negative current coupling factor for analog inputs ⁵⁾	K_{OVA}	–	2.5×10^{-4}	1.5×10^{-3}	–	$I_{OV} < 0$
Overload positive current coupling factor for digital I/O pins ⁵⁾	K_{OVD}	–	1.0×10^{-4}	5.0×10^{-3}	–	$I_{OV} > 0$
Overload negative current coupling factor for digital I/O pins ⁵⁾	K_{OVD}	–	1.0×10^{-2}	3.0×10^{-2}	–	$I_{OV} < 0$
Absolute sum of overload currents	$\Sigma IOV $	–	–	50	mA	4)

Electrical Parameters

Table 12 Operating Condition Parameters (cont'd)

Parameter	Symbol	Values			Unit	Note / Test Condition
		Min.	Typ.	Max.		
External Pin Load Capacitance	C_L	–	20	–	pF	Pin drivers in default mode ⁶⁾
Voltage Regulator Buffer Capacitance for DMP_M	C_{EVRM}	1.0	–	4.7	μF	⁷⁾
Voltage Regulator Buffer Capacitance for DMP_1	C_{EVR1}	0.47	–	2.2	μF	One for each supply pin ⁷⁾
Operating frequency	f_{SYS}	–	–	80	MHz	⁸⁾
Ambient temperature	T_A	–	–	–	°C	See Table 1

- 1) If both core power domains are clocked, the difference between the power supply voltages must be less than 10 mV. This condition imposes additional constraints when using external power supplies.
Do not combine internal and external supply of different core power domains.
Do not supply the core power domains with two independent external voltage regulators. The simplest method is to supply both power domains directly via a single external power supply.
- 2) Performance of pad drivers, A/D Converter, and Flash module depends on V_{DDP} .
If the external supply voltage V_{DDP} becomes lower than the specified operating range, a power reset must be generated. Otherwise, the core supply voltage V_{DD1} may rise above its specified operating range due to parasitic effects.
This power reset can be generated by the on-chip SWD. If the SWD is disabled the power reset must be generated by activating the \overline{PORST} input.
- 3) Overload conditions occur if the standard operating conditions are exceeded, i.e. the voltage on any pin exceeds the specified range: $V_{OV} > V_{IHmax}$ ($I_{OV} > 0$) or $V_{OV} < V_{ILmin}$ ($I_{OV} < 0$). The absolute sum of input overload currents on all pins may not exceed **50 mA**. The supply voltages must remain within the specified limits. Proper operation under overload conditions depends on the application.
Overload conditions must not occur on pin XTAL1 (powered by V_{DD1}).
- 4) Not subject to production test - verified by design/characterization.
- 5) An overload current (I_{OV}) through a pin injects an error current (I_{INJ}) into the adjacent pins. This error current adds to that pin's leakage current (I_{OZ}). The value of the error current depends on the overload current and is defined by the overload coupling factor K_{OV} . The polarity of the injected error current is reversed from the polarity of the overload current that produces it.
The total current through a pin is $|I_{TOT}| = |I_{OZ}| + (|I_{OV}| \times K_{OV})$. The additional error current may distort the input voltage on analog inputs.
- 6) The timing is valid for pin drivers operating in default current mode (selected after reset). Reducing the output current may lead to increased delays or reduced driving capability (C_L).
- 7) To ensure the stability of the voltage regulators the EVRs must be buffered with ceramic capacitors. Separate buffer capacitors with the recommended values shall be connected as close as possible to each V_{DD1} pin to keep the resistance of the board tracks below 2 Ω. Connect all V_{DD1} pins together.
The minimum capacitance value is required for proper operation under all conditions (e.g. temperature). Higher values slightly increase the startup time.
- 8) The operating frequency range may be reduced for specific types of the XE167. This is indicated in the device designation (...FxxL). 80-MHz devices are marked ...F80L.

Parameter Interpretation

The parameters listed in the following include both the characteristics of the XE167 and its demands on the system. To aid in correctly interpreting the parameters when evaluating them for a design, they are marked accordingly in the column "Symbol":

CC (Controller Characteristics):

The logic of the XE167 provides signals with the specified characteristics.

SR (System Requirement):

The external system must provide signals with the specified characteristics to the XE167.

4.2 DC Parameters

These parameters are static or average values that may be exceeded during switching transitions (e.g. output current).

The XE167 can operate within a wide supply voltage range from 3.0 V to 5.5 V. However, during operation this supply voltage must remain within 10 percent of the selected nominal supply voltage. It cannot vary across the full operating voltage range.

Because of the supply voltage restriction and because electrical behavior depends on the supply voltage, the parameters are specified separately for the upper and the lower voltage range.

During operation, the supply voltages may only change with a maximum speed of $dV/dt < 1 \text{ V/ms}$.

Leakage current is strongly dependent on the operating temperature and the voltage level at the respective pin. The maximum values in the following tables apply under worst case conditions, i.e. maximum temperature and an input level equal to the supply voltage.

The value for the leakage current in an application can be determined by using the respective leakage derating formula (see tables) with values from that application.

The pads of the XE167 are designed to operate in various driver modes. The DC parameter specifications refer to the current limits in [Table 13](#).

Table 13 Current Limits for Port Output Drivers

Port Output Driver Mode	Maximum Output Current (I_{OLmax} , $-I_{OHmax}$) ¹⁾		Nominal Output Current (I_{OLnom} , $-I_{OHnom}$)	
	$V_{DDP} \geq 4.5 \text{ V}$	$V_{DDP} < 4.5 \text{ V}$	$V_{DDP} \geq 4.5 \text{ V}$	$V_{DDP} < 4.5 \text{ V}$
Strong driver	10 mA	10 mA	2.5 mA	2.5 mA
Medium driver	4.0 mA	2.5 mA	1.0 mA	1.0 mA
Weak driver	0.5 mA	0.5 mA	0.1 mA	0.1 mA

1) An output current above $|I_{OXnom}|$ may be drawn from up to three pins at the same time. For any group of 16 neighboring output pins, the total output current in each direction (ΣI_{OL} and $\Sigma -I_{OH}$) must remain below 50 mA.

Pullup/Pulldown Device Behavior

Most pins of the XE167 feature pullup or pulldown devices. For some special pins these are fixed; for the port pins they can be selected by the application.

The specified current values indicate how to load the respective pin depending on the intended signal level. **Figure 12** shows the current paths.

The shaded resistors shown in the figure may be required to compensate system pull currents that do not match the given limit values.

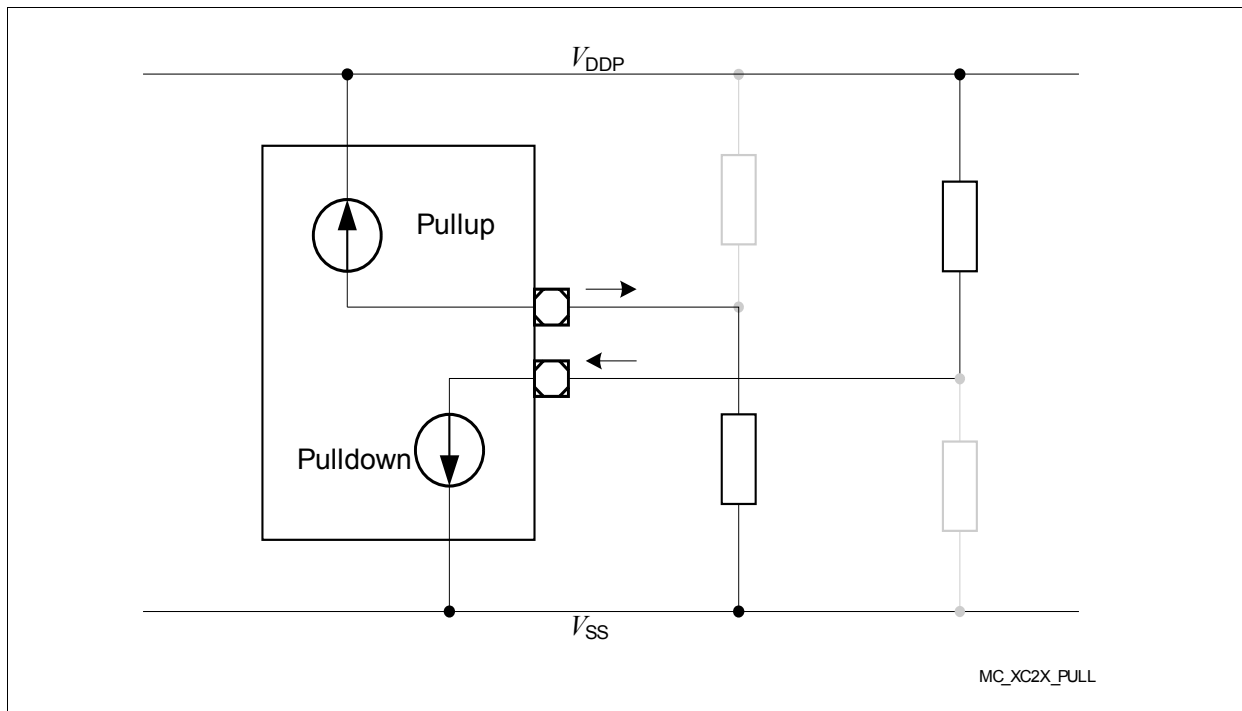

Figure 12 Pullup/Pulldown Current Definition

4.2.1 DC Parameters for Upper Voltage Area

These parameters apply to the upper IO voltage range, $4.5\text{ V} \leq V_{DDP} \leq 5.5\text{ V}$.

Table 14 DC Characteristics for Upper Voltage Range (Operating Conditions apply)¹⁾

Parameter	Symbol	Values			Unit	Note / Test Condition
		Min.	Typ.	Max.		
Input low voltage (all except XTAL1)	V_{IL} SR	-0.3	–	$0.3 \times V_{DDP}$	V	–
Input high voltage (all except XTAL1)	V_{IH} SR	$0.7 \times V_{DDP}$	–	$V_{DDP} + 0.3$	V	–
Input Hysteresis ²⁾	HYS CC	$0.11 \times V_{DDP}$	–	–	V	V_{DDP} in [V], Series resistance = $0\ \Omega$
Output low voltage	V_{OL} CC	–	–	1.0	V	$I_{OL} \leq I_{OLmax}$ ³⁾
Output low voltage	V_{OL} CC	–	–	0.4	V	$I_{OL} \leq I_{OLnom}$ ³⁾⁴⁾
Output high voltage ⁵⁾	V_{OH} CC	$V_{DDP} - 1.0$	–	–	V	$I_{OH} \geq I_{OHmax}$ ³⁾
Output high voltage ⁵⁾	V_{OH} CC	$V_{DDP} - 0.4$	–	–	V	$I_{OH} \geq I_{OHnom}$ ³⁾⁴⁾
Input leakage current (Port 5, Port 15) ⁶⁾	I_{OZ1} CC	–	± 10	± 200	nA	$0\text{ V} < V_{IN} < V_{DDP}$
Input leakage current (all other) ⁶⁾⁷⁾	I_{OZ2} CC	–	± 0.2	± 5	μA	$T_J \leq 110^\circ\text{C}$, $0.45\text{ V} < V_{IN} < V_{DDP}$
Pull level keep current	I_{PLK}	–	–	± 30	μA	$V_{PIN} \geq V_{IH}$ (up) ⁸⁾ $V_{PIN} \leq V_{IL}$ (dn)
Pull level force current	I_{PLF}	± 250	–	–	μA	$V_{PIN} \leq V_{IL}$ (up) ⁸⁾ $V_{PIN} \geq V_{IH}$ (dn)
Pin capacitance ⁹⁾ (digital inputs/outputs)	C_{IO} CC	–	–	10	pF	

1) Keeping signal levels within the limits specified in this table ensures operation without overload conditions. For signal levels outside these specifications, also refer to the specification of the overload current I_{OV} .

2) Not subject to production test - verified by design/characterization. Hysteresis is implemented to avoid metastable states and switching due to internal ground bounce. It cannot suppress switching due to external system noise under all conditions.

3) The maximum deliverable output current of a port driver depends on the selected output driver mode, see [Table 13, Current Limits for Port Output Drivers](#). The limit for pin groups must be respected.

Electrical Parameters

- 4) As a rule, with decreasing output current the output levels approach the respective supply level ($V_{OL} \rightarrow V_{SS}$, $V_{OH} \rightarrow V_{DDP}$). However, only the levels for nominal output currents are verified.
- 5) This specification is not valid for outputs which are switched to open drain mode. In this case the respective output will float and the voltage is determined by the external circuit.
- 6) An additional error current (I_{INJ}) will flow if an overload current flows through an adjacent pin. Please refer to the definition of the overload coupling factor K_{OV} .
- 7) The given values are worst-case values. In production test, this leakage current is only tested at 125°C; other values are ensured by correlation. For derating, please refer to the following descriptions:
 Leakage derating depending on temperature (T_J = junction temperature [°C]):
 $I_{OZ} = 0.05 \times e^{(1.5 + 0.028 \times T_J)}$ [μA]. For example, at a temperature of 95°C the resulting leakage current is 3.2 μA.
 Leakage derating depending on voltage level ($DV = V_{DDP} - V_{PIN}$ [V]):
 $I_{OZ} = I_{OZtempmax} - (1.6 \times DV)$ [μA]
 This voltage derating formula is an approximation which applies for maximum temperature.
 Because pin P2.8 is connected to two pads (standard pad and high-speed clock pad), it has twice the normal leakage.
- 8) Keep current: Limit the current through this pin to the indicated value so that the enabled pull device can keep the default pin level: $V_{PIN} \geq V_{IH}$ for a pullup; $V_{PIN} \leq V_{IL}$ for a pulldown.
 Force current: Drive the indicated minimum current through this pin to change the default pin level driven by the enabled pull device: $V_{PIN} \leq V_{IL}$ for a pullup; $V_{PIN} \geq V_{IH}$ for a pulldown.
 These values apply to the fixed pull-devices in dedicated pins and to the user-selectable pull-devices in general purpose IO pins.
- 9) Not subject to production test - verified by design/characterization.
 Because pin P2.8 is connected to two pads (standard pad and high-speed clock pad), it has twice the normal capacitance.

4.2.2 DC Parameters for Lower Voltage Area

These parameters apply to the lower IO voltage range, $3.0\text{ V} \leq V_{DDP} \leq 4.5\text{ V}$.

Table 15 DC Characteristics for Lower Voltage Range (Operating Conditions apply)¹⁾

Parameter	Symbol	Values			Unit	Note / Test Condition
		Min.	Typ.	Max.		
Input low voltage (all except XTAL1)	V_{IL} SR	-0.3	–	$0.3 \times V_{DDP}$	V	–
Input high voltage (all except XTAL1)	V_{IH} SR	$0.7 \times V_{DDP}$	–	$V_{DDP} + 0.3$	V	–
Input Hysteresis ²⁾	HYS CC	$0.07 \times V_{DDP}$	–	–	V	V_{DDP} in [V], Series resistance = $0\ \Omega$
Output low voltage	V_{OL} CC	–	–	1.0	V	$I_{OL} \leq I_{OLmax}$ ³⁾
Output low voltage	V_{OL} CC	–	–	0.4	V	$I_{OL} \leq I_{OLnom}$ ³⁾⁴⁾
Output high voltage ⁵⁾	V_{OH} CC	$V_{DDP} - 1.0$	–	–	V	$I_{OH} \geq I_{OHmax}$ ³⁾
Output high voltage ⁵⁾	V_{OH} CC	$V_{DDP} - 0.4$	–	–	V	$I_{OH} \geq I_{OHnom}$ ³⁾⁴⁾
Input leakage current (Port 5, Port 15) ⁶⁾	I_{OZ1} CC	–	± 10	± 200	nA	$0\text{ V} < V_{IN} < V_{DDP}$
Input leakage current (all other) ⁶⁾⁷⁾	I_{OZ2} CC	–	± 0.2	± 2.5	μA	$T_J \leq 110^\circ\text{C}$, $0.45\text{ V} < V_{IN} < V_{DDP}$
Pull level keep current	I_{PLK}	–	–	± 10	μA	$V_{PIN} \geq V_{IH}$ (up) ⁸⁾ $V_{PIN} \leq V_{IL}$ (dn)
Pull level force current	I_{PLF}	± 150	–	–	μA	$V_{PIN} \leq V_{IL}$ (up) ⁸⁾ $V_{PIN} \geq V_{IH}$ (dn)
Pin capacitance ⁹⁾ (digital inputs/outputs)	C_{IO} CC	–	–	10	pF	

1) Keeping signal levels within the limits specified in this table ensures operation without overload conditions. For signal levels outside these specifications, also refer to the specification of the overload current I_{OV} .

2) Not subject to production test - verified by design/characterization. Hysteresis is implemented to avoid metastable states and switching due to internal ground bounce. It cannot suppress switching due to external system noise under all conditions.

3) The maximum deliverable output current of a port driver depends on the selected output driver mode, see [Table 13, Current Limits for Port Output Drivers](#). The limit for pin groups must be respected.

Electrical Parameters

- 4) As a rule, with decreasing output current the output levels approach the respective supply level ($V_{OL} \rightarrow V_{SS}$, $V_{OH} \rightarrow V_{DDP}$). However, only the levels for nominal output currents are verified.
- 5) This specification is not valid for outputs which are switched to open drain mode. In this case the respective output will float and the voltage is determined by the external circuit.
- 6) An additional error current (I_{INJ}) will flow if an overload current flows through an adjacent pin. Please refer to the definition of the overload coupling factor K_{OV} .
The leakage current value is not tested in the lower voltage range but only in the upper voltage range. This parameter is ensured by correlation.
- 7) The given values are worst-case values. In production test, this leakage current is only tested at 125°C; other values are ensured by correlation. For derating, please refer to the following descriptions:
Leakage derating depending on temperature (T_J = junction temperature [°C]):
 $I_{OZ} = 0.03 \times e^{(1.35 + 0.028 \times T_J)}$ [μA]. For example, at a temperature of 95°C the resulting leakage current is 1.65 μA.
Leakage derating depending on voltage level ($DV = V_{DDP} - V_{PIN}$ [V]):
 $I_{OZ} = I_{OZtempmax} - (1.3 \times DV)$ [μA]
This voltage derating formula is an approximation which applies for maximum temperature.
Because pin P2.8 is connected to two pads (standard pad and high-speed clock pad), it has twice the normal leakage.
- 8) Keep current: Limit the current through this pin to the indicated value so that the enabled pull device can keep the default pin level: $V_{PIN} \geq V_{IH}$ for a pullup; $V_{PIN} \leq V_{IL}$ for a pulldown.
Force current: Drive the indicated minimum current through this pin to change the default pin level driven by the enabled pull device: $V_{PIN} \leq V_{IL}$ for a pullup; $V_{PIN} \geq V_{IH}$ for a pulldown.
These values apply to the fixed pull-devices in dedicated pins and to the user-selectable pull-devices in general purpose IO pins.
- 9) Not subject to production test - verified by design/characterization.
Because pin P2.8 is connected to two pads (standard pad and high-speed clock pad), it has twice the normal capacitance.

4.2.3 Power Consumption

The power consumed by the XE167 depends on several factors such as supply voltage, operating frequency, active circuits, and operating temperature. The power consumption specified here consists of two components:

- The switching current I_S depends on the device activity
- The leakage current I_{LK} depends on the device temperature

To determine the actual power consumption, always both components, switching current I_S (**Table 16**) and leakage current I_{LK} (**Table 17**) must be added:

$$I_{DDP} = I_S + I_{LK}$$

Note: The power consumption values are not subject to production test. They are verified by design/characterization.

To determine the total power consumption for dimensioning the external power supply, also the pad driver currents must be considered.

The given power consumption parameters and their values refer to specific operating conditions:

- **Active mode:**
Regular operation, i.e. peripherals are active, code execution out of Flash.
- **Stopover mode:**
Crystal oscillator and PLL stopped, Flash switched off, clock in domain DMP_1 stopped.

Note: The maximum values cover the complete specified operating range of all manufactured devices.

The typical values refer to average devices under typical conditions, such as nominal supply voltage, room temperature, application-oriented activity.

*After a power reset, the decoupling capacitors for V_{DDI} are charged with the maximum possible current, see parameter I_{CC} in **Table 20**.*

For additional information, please refer to **Section 5.2, Thermal Considerations**.

**Table 16 Switching Power Consumption XE167
(Operating Conditions apply)**

Parameter	Sym- bol	Values			Unit	Note / Test Condition
		Min.	Typ.	Max.		
Power supply current (active) with all peripherals active and EVVRs on	I_{SACT}	–	10 + $0.6 \times f_{SYS}$	10 + $1.0 \times f_{SYS}$	mA	Active mode ¹⁾²⁾ f_{SYS} in [MHz]
Power supply current in stopover mode, EVVRs on	I_{SSO}	–	1.0	2.0	mA	Stopover Mode ²⁾

1) The pad supply voltage pins (V_{DDPB}) provide the input current for the on-chip EVVRs and the current consumed by the pin output drivers. A small current is consumed because the drivers' input stages are switched.

2) The pad supply voltage has only a minor influence on this parameter.

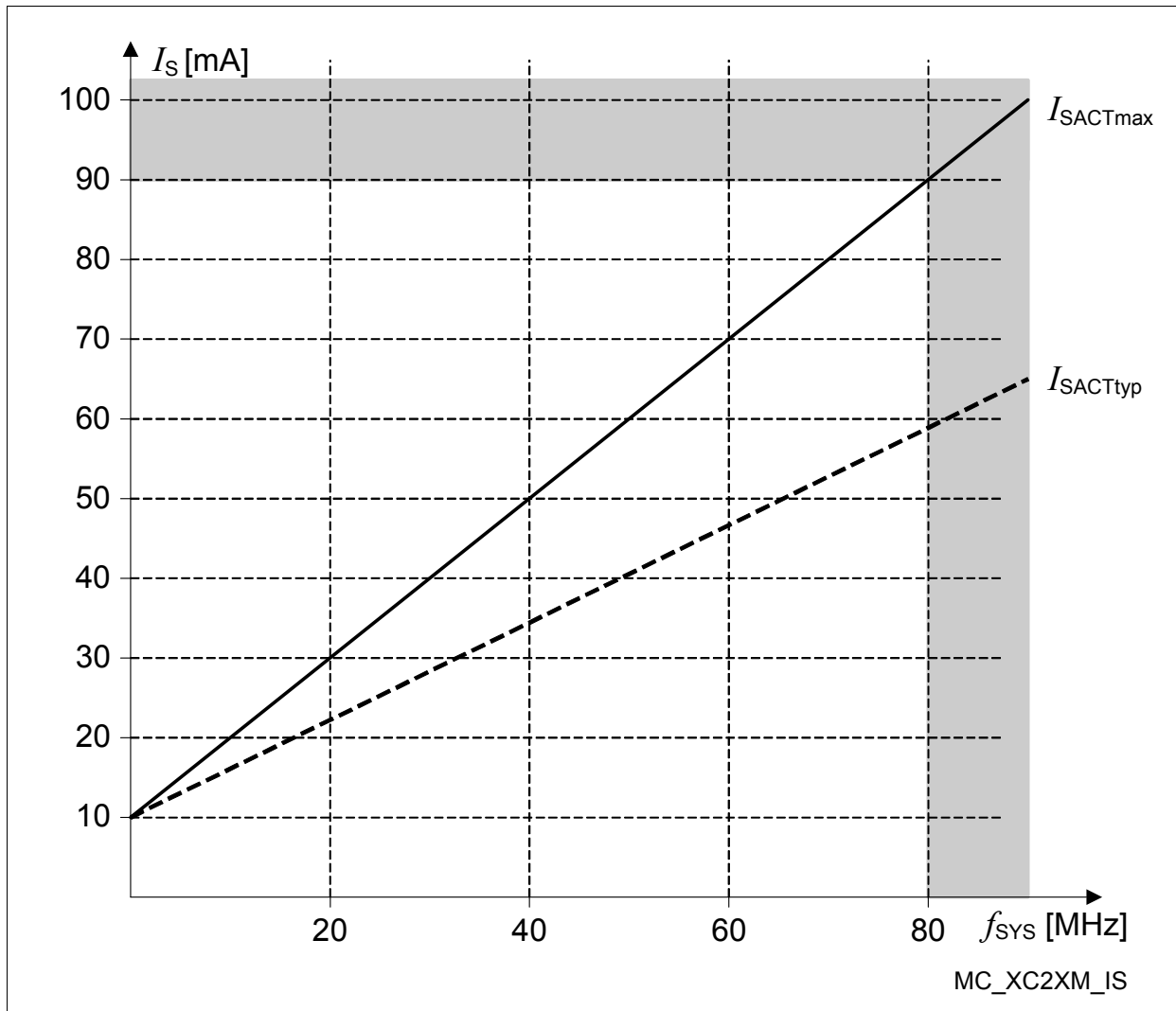

Figure 13 Supply Current in Active Mode as a Function of Frequency

**Table 17 Leakage Power Consumption XE167
(Operating Conditions apply)**

Parameter	Sym- bol	Values			Unit	Note / Test Condition ¹⁾
		Min.	Typ.	Max.		
Leakage supply current ²⁾ Formula ³⁾ : $600,000 \times e^{-\alpha}$; $\alpha = 5000 / (273 + B \times T_J)$; Typ.: B = 1.0, Max.: B = 1.3	I_{LK1}	–	0.03	0.05	mA	$T_J = 25^\circ\text{C}$
		–	0.5	1.3	mA	$T_J = 85^\circ\text{C}$
		–	2.1	6.2	mA	$T_J = 125^\circ\text{C}$

- 1) All inputs (including pins configured as inputs) are set at 0 V to 0.1 V or at $V_{DDP} - 0.1$ V to V_{DDP} and all outputs (including pins configured as outputs) are disconnected.
- 2) The supply current caused by leakage depends mainly on the junction temperature (see [Figure 14](#)) and the supply voltage. The temperature difference between the junction temperature T_J and the ambient temperature T_A must be taken into account. As this fraction of the supply current does not depend on device activity, it must be added to other power consumption values.
- 3) This formula is valid for temperatures above 0°C. For temperatures below 0°C a value of below 10 µA can be assumed.

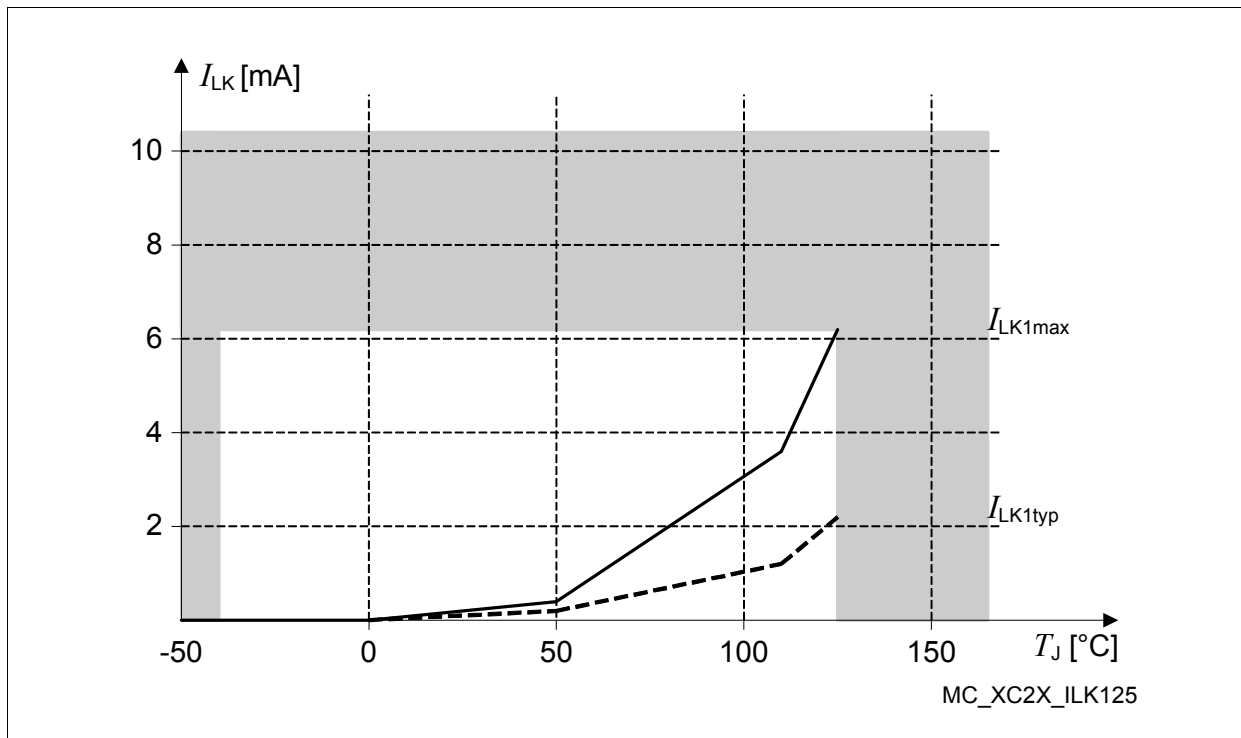

Figure 14 Leakage Supply Current as a Function of Temperature

4.3 Analog/Digital Converter Parameters

These parameters describe the conditions for optimum ADC performance.

Table 18 A/D Converter Characteristics
(Operating Conditions apply)

Parameter	Symbol		Limit Values		Unit	Test Condition
			Min.	Max.		
Analog reference supply	V_{AREF}	SR	$V_{AGND} + 1.0$	$V_{DDPA} + 0.05$	V	1)
Analog reference ground	V_{AGND}	SR	$V_{SS} - 0.05$	$V_{AREF} - 1.0$	V	–
Analog input voltage range	V_{AIN}	SR	V_{AGND}	V_{AREF}	V	2)
Analog clock frequency	f_{ADCI}		0.5	20	MHz	3)
Conversion time for 10-bit result ⁴⁾	t_{C10}	CC	$(13 + STC) \times t_{ADCI} + 2 \times t_{SYS}$		–	–
Conversion time for 8-bit result ⁴⁾	t_{C8}	CC	$(11 + STC) \times t_{ADCI} + 2 \times t_{SYS}$		–	–
Wakeup time from analog powerdown, fast mode	t_{WAF}	CC	–	1	μ s	–
Wakeup time from analog powerdown, slow mode	t_{WAS}	CC	–	10	μ s	–
Total unadjusted error ⁵⁾	TUE	CC	–	± 2	LSB	$V_{AREF} = 5.0 \text{ V}^{1)}$
DNL error	EA_{DNL}	CC	–	± 1	LSB	
INL error	EA_{INL}	CC	–	± 1.2	LSB	
Gain error	EA_{GAIN}	CC	–	± 0.8	LSB	
Offset error	EA_{OFF}	CC	–	± 0.8	LSB	
Total capacitance of an analog input	C_{AINT}	CC	–	10	pF	6)7)
Switched capacitance of an analog input	C_{AINS}	CC	–	4	pF	6)7)
Resistance of the analog input path	R_{AIN}	CC	–	1.5	k Ω	6)7)
Total capacitance of the reference input	C_{AREFT}	CC	–	15	pF	6)7)

Table 18 A/D Converter Characteristics (cont'd)
(Operating Conditions apply)

Parameter	Symbol	Limit Values		Unit	Test Condition
		Min.	Max.		
Switched capacitance of the reference input	C_{AREFS} CC	–	7	pF	6)7)
Resistance of the reference input path	R_{AREF} CC	–	2	k Ω	6)7)

- 1) TUE is tested at $V_{AREF_x} = V_{DDPA}$, $V_{AGND} = 0$ V. It is verified by design for all other voltages within the defined voltage range.
The specified TUE is valid only if the absolute sum of input overload currents on Port 5 or Port 15 pins (see I_{OV} specification) does not exceed 10 mA, and if V_{AREF} and V_{AGND} remain stable during the measurement time.
- 2) V_{AIN} may exceed V_{AGND} or V_{AREF_x} up to the absolute maximum ratings. However, the conversion result in these cases will be X000_H or X3FF_H, respectively.
- 3) The limit values for f_{ADCI} must not be exceeded when selecting the peripheral frequency and the prescaler setting.
- 4) This parameter includes the sample time (also the additional sample time specified by STC), the time to determine the digital result and the time to load the result register with the conversion result.
Values for the basic clock t_{ADCI} depend on programming and are found in [Table 19](#).
- 5) The total unadjusted error TUE is the maximum deviation from the ideal ADC transfer curve, not the sum of individual errors.
All error specifications are based on measurement methods standardized by IEEE 1241.2000.
- 6) Not subject to production test - verified by design/characterization.
- 7) These parameter values cover the complete operating range. Under relaxed operating conditions (temperature, supply voltage) typical values can be used for calculation. At room temperature and nominal supply voltage the following typical values can be used:
 $C_{AINT_{typ}} = 12$ pF, $C_{AINSt_{typ}} = 5$ pF, $R_{AIN_{typ}} = 1.0$ k Ω , $C_{AREF_{T_{typ}}} = 15$ pF, $C_{AREF_{St_{typ}}} = 10$ pF, $R_{AREF_{typ}} = 1.0$ k Ω .

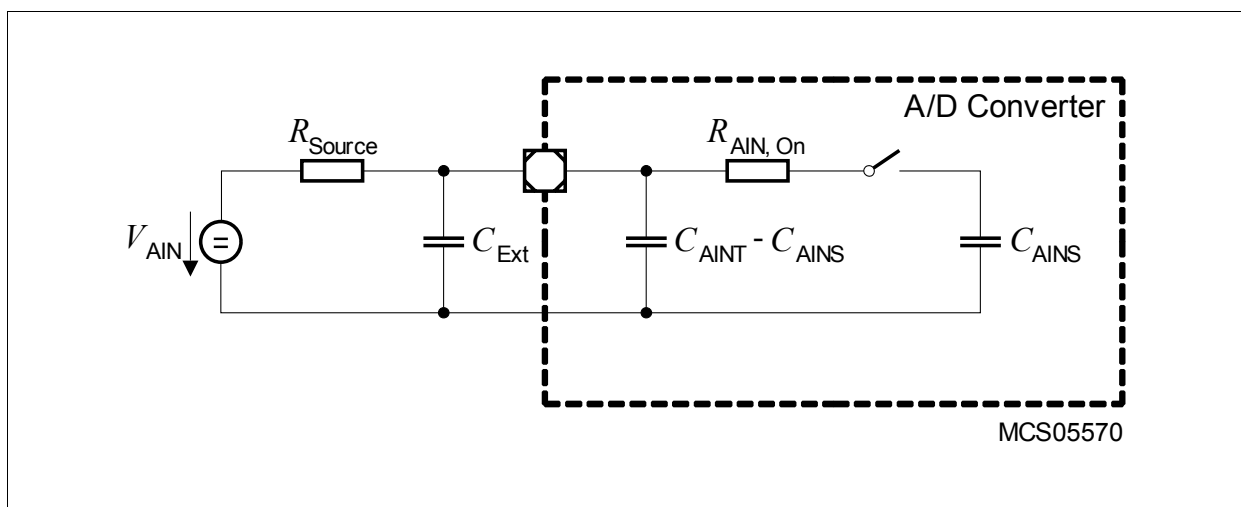

Figure 15 Equivalent Circuitry for Analog Inputs

Electrical Parameters

Sample time and conversion time of the XE167's A/D converters are programmable. The timing above can be calculated using [Table 19](#).

The limit values for f_{ADCI} must not be exceeded when selecting the prescaler value.

Table 19 A/D Converter Computation Table

GLOBCTR.5-0 (DIVA)	A/D Converter Analog Clock f_{ADCI}	INPCRx.7-0 (STC)	Sample Time t_s
000000 _B	f_{SYS}	00 _H	$t_{\text{ADCI}} \times 2$
000001 _B	$f_{\text{SYS}} / 2$	01 _H	$t_{\text{ADCI}} \times 3$
000010 _B	$f_{\text{SYS}} / 3$	02 _H	$t_{\text{ADCI}} \times 4$
:	$f_{\text{SYS}} / (\text{DIVA}+1)$:	$t_{\text{ADCI}} \times (\text{STC}+2)$
111110 _B	$f_{\text{SYS}} / 63$	FE _H	$t_{\text{ADCI}} \times 256$
111111 _B	$f_{\text{SYS}} / 64$	FF _H	$t_{\text{ADCI}} \times 257$

Converter Timing Example A:

Assumptions: $f_{\text{SYS}} = 80 \text{ MHz}$ (i.e. $t_{\text{SYS}} = 12.5 \text{ ns}$), DIVA = 03_H, STC = 00_H
 Analog clock $f_{\text{ADCI}} = f_{\text{SYS}} / 4 = 20 \text{ MHz}$, i.e. $t_{\text{ADCI}} = 50 \text{ ns}$
 Sample time $t_s = t_{\text{ADCI}} \times 2 = 100 \text{ ns}$

Conversion 10-bit:

$$t_{\text{C10}} = 13 \times t_{\text{ADCI}} + 2 \times t_{\text{SYS}} = 13 \times 50 \text{ ns} + 2 \times 12.5 \text{ ns} = 0.675 \mu\text{s}$$

Conversion 8-bit:

$$t_{\text{C8}} = 11 \times t_{\text{ADCI}} + 2 \times t_{\text{SYS}} = 11 \times 50 \text{ ns} + 2 \times 12.5 \text{ ns} = 0.575 \mu\text{s}$$

Converter Timing Example B:

Assumptions: $f_{\text{SYS}} = 40 \text{ MHz}$ (i.e. $t_{\text{SYS}} = 25 \text{ ns}$), DIVA = 02_H, STC = 03_H
 Analog clock $f_{\text{ADCI}} = f_{\text{SYS}} / 3 = 13.3 \text{ MHz}$, i.e. $t_{\text{ADCI}} = 75 \text{ ns}$
 Sample time $t_s = t_{\text{ADCI}} \times 5 = 375 \text{ ns}$

Conversion 10-bit:

$$t_{\text{C10}} = 16 \times t_{\text{ADCI}} + 2 \times t_{\text{SYS}} = 16 \times 75 \text{ ns} + 2 \times 25 \text{ ns} = 1.25 \mu\text{s}$$

Conversion 8-bit:

$$t_{\text{C8}} = 14 \times t_{\text{ADCI}} + 2 \times t_{\text{SYS}} = 14 \times 75 \text{ ns} + 2 \times 25 \text{ ns} = 1.10 \mu\text{s}$$

4.4 System Parameters

The following parameters specify several aspects which are important when integrating the XE167 into an application system.

Note: These parameters are not subject to production test but verified by design and/or characterization.

Table 20 Various System Parameters

Parameter	Symbol	Values			Unit	Note / Test Condition
		Min.	Typ.	Max.		
Supply watchdog (SWD) supervision level (see Table 21)	V_{SWD} CC	$V_{\text{LV}} - 0.150$	V_{LV}	$V_{\text{LV}} + 0.100$	V	V_{LV} = selected voltage in upper voltage area
		$V_{\text{LV}} - 0.125$	V_{LV}	$V_{\text{LV}} + 0.050$	V	V_{LV} = selected voltage in lower voltage area
Core voltage (PVC) supervision level (see Table 22)	V_{PVC} CC	$V_{\text{LV}} - 0.070$	V_{LV}	$V_{\text{LV}} + 0.030$	V	V_{LV} = selected voltage
Current control limit	I_{CC} CC	13	–	30	mA	Power domain DMP_M
		90	–	150	mA	Power domain DMP_1
Wakeup clock source frequency	f_{WU} CC	400	500	600	kHz	FREQSEL = 00 _B
Internal clock source frequency	f_{INT} CC	4.8	5.0	5.2	MHz	
Startup time from stopover mode	t_{SSO} CC	200	260	320	μs	User instruction from PSRAM

Table 21 Coding of Bitfields LEVxV in Register SWDCON0

Code	Default Voltage Level	Notes¹⁾
0000 _B	2.9 V	
0001 _B	3.0 V	LEV1V: reset request
0010 _B	3.1 V	
0011 _B	3.2 V	
0100 _B	3.3 V	
0101 _B	3.4 V	
0110 _B	3.6 V	
0111 _B	4.0 V	
1000 _B	4.2 V	
1001 _B	4.5 V	LEV2V: no request
1010 _B	4.6 V	
1011 _B	4.7 V	
1100 _B	4.8 V	
1101 _B	4.9 V	
1110 _B	5.0 V	
1111 _B	5.5 V	

1) The indicated default levels are selected automatically after a power reset.

Table 22 Coding of Bitfields LEVxV in Registers PVCyCONz

Code	Default Voltage Level	Notes¹⁾
000 _B	0.9 V	
001 _B	1.0 V	
010 _B	1.1 V	
011 _B	1.2 V	
100 _B	1.3 V	LEV1V: reset request
101 _B	1.4 V	LEV2V: interrupt request
110 _B	1.5 V	
111 _B	1.6 V	

1) The indicated default levels are selected automatically after a power reset.

4.5 Flash Memory Parameters

The XE167 is delivered with all Flash sectors erased and with no protection installed.

The data retention time of the XE167's Flash memory (i.e. the time after which stored data can still be retrieved) depends on the number of times the Flash memory has been erased and programmed.

Note: These parameters are not subject to production test but verified by design and/or characterization.

Table 23 Flash Characteristics
(Operating Conditions apply)

Parameter	Symbol	Limit Values			Unit	Note / Test Condition
		Min.	Typ.	Max.		
Programming time per 128-byte page	t_{PR}	–	3 ¹⁾	3.5	ms	ms
Erase time per sector/page	t_{ER}	–	4 ¹⁾	5	ms	ms
Data retention time	t_{RET}	20	–	–	years	1,000 erase / program cycles
Flash erase endurance for user sectors ²⁾	N_{ER}	15,000	–	–	cycles	Data retention time 5 years
Flash erase endurance for security pages	N_{SEC}	10	–	–	cycles	Data retention time 20 years
Drain disturb limit	N_{DD}	64	–	–	cycles	³⁾

1) Programming and erase times depend on the internal Flash clock source. The control state machine needs a few system clock cycles. This requirement is only relevant for extremely low system frequencies.

In the XE167 erased areas must be programmed completely (with actual code/data or dummy values) before that area is read.

2) A maximum of 64 Flash sectors can be cycled 15,000 times. For all other sectors the limit is 1,000 cycles.

3) This parameter limits the number of subsequent programming operations within a physical sector. The drain disturb limit is applicable if wordline erase is used repeatedly. For normal sector erase/program cycles this limit will not be violated.

Access to the XE167 Flash modules is controlled by the IMB. Built-in prefetch mechanisms optimize the performance for sequential access.

Flash access waitstates only affect non-sequential access. Due to prefetch mechanisms, the performance for sequential access (depending on the software structure) is only partially influenced by waitstates.

Table 24 Flash Access Waitstates

Required Waitstates	System Frequency Range
4 WS (WSFLASH = 100 _B)	$f_{\text{SYS}} \leq f_{\text{SYSmax}}$
3 WS (WSFLASH = 011 _B)	$f_{\text{SYS}} \leq 17 \text{ MHz}$
2 WS (WSFLASH = 010 _B)	$f_{\text{SYS}} \leq 13 \text{ MHz}$
1 WS (WSFLASH = 001 _B)	$f_{\text{SYS}} \leq 8 \text{ MHz}$
0 WS (WSFLASH = 000 _B)	Forbidden! Must not be selected!

Note: The maximum achievable system frequency is limited by the properties of the respective derivative.

4.6 AC Parameters

These parameters describe the dynamic behavior of the XE167.

4.6.1 Testing Waveforms

These values are used for characterization and production testing (except pin XTAL1).

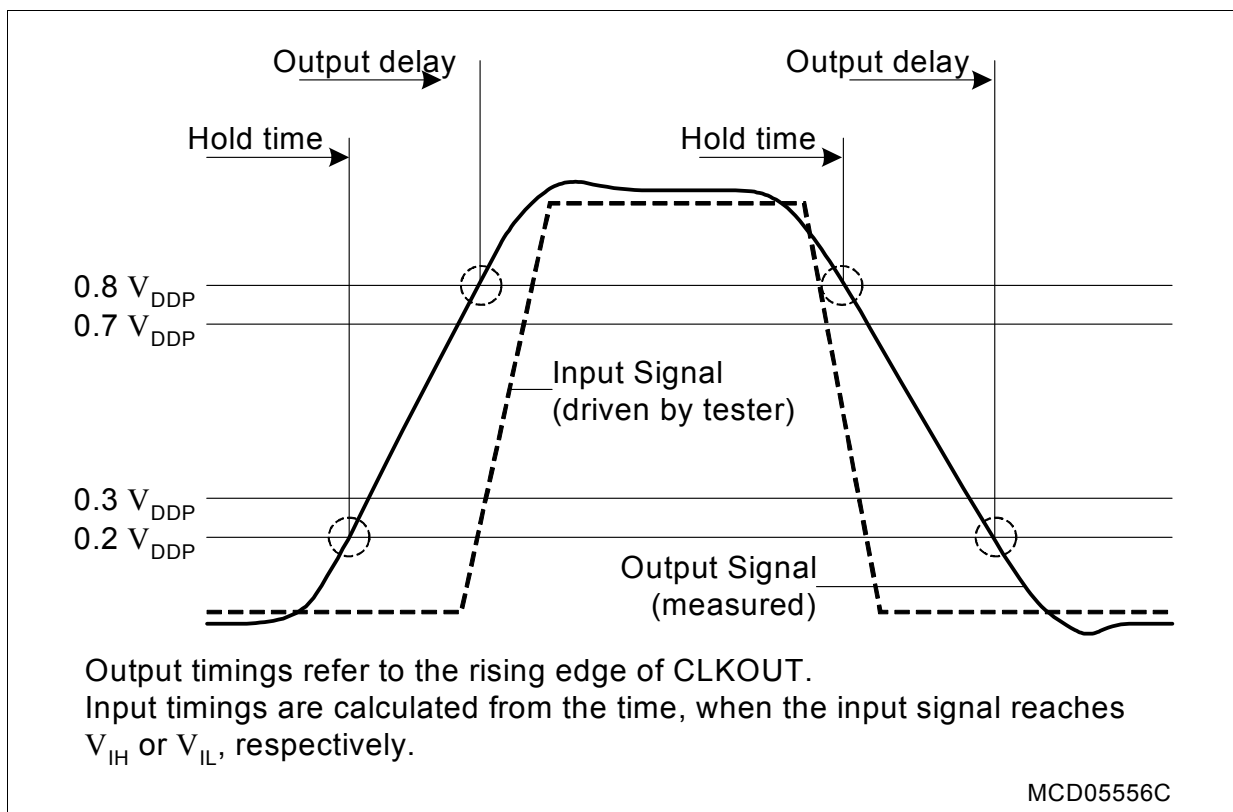

Figure 16 Input Output Waveforms

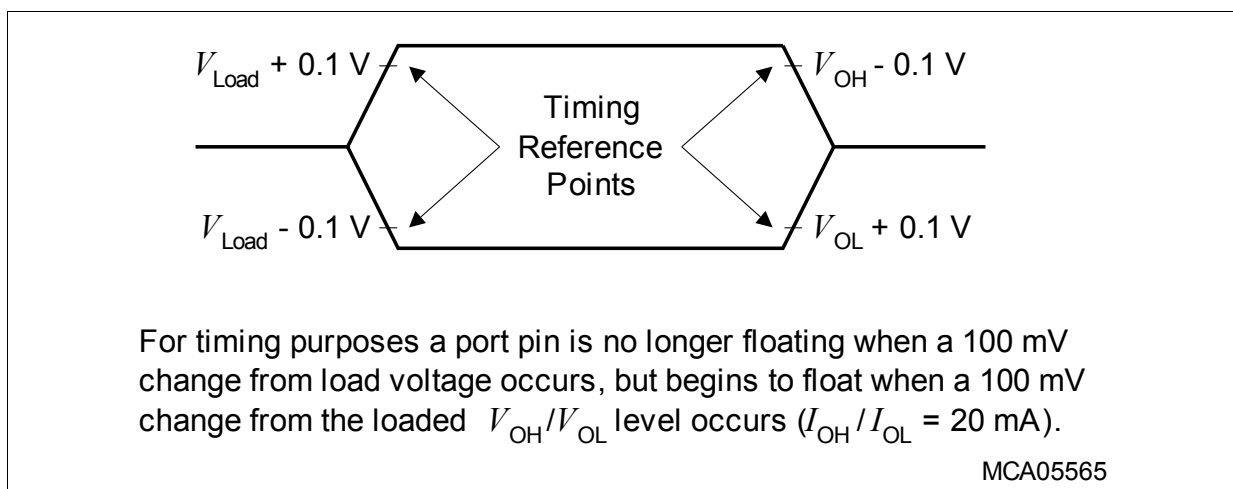

Figure 17 Floating Waveforms

4.6.2 Definition of Internal Timing

The internal operation of the XE167 is controlled by the internal system clock f_{SYS} .

Because the system clock signal f_{SYS} can be generated from a number of internal and external sources using different mechanisms, the duration of the system clock periods (TCSs) and their variation (as well as the derived external timing) depend on the mechanism used to generate f_{SYS} . This must be considered when calculating the timing for the XE167.

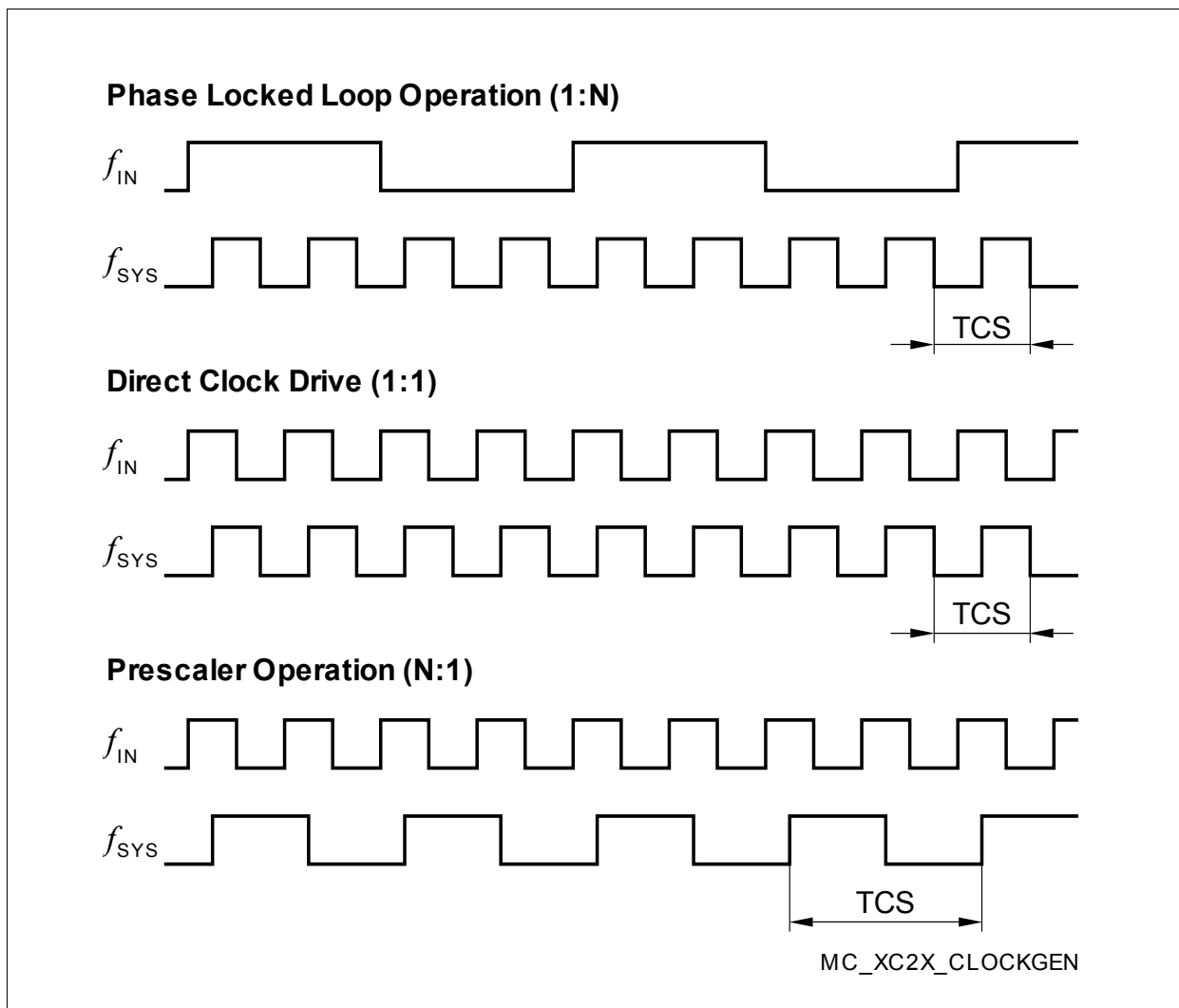

Figure 18 Generation Mechanisms for the System Clock

Note: The example of PLL operation shown in [Figure 18](#) uses a PLL factor of 1:4; the example of prescaler operation uses a divider factor of 2:1.

The specification of the external timing (AC Characteristics) depends on the period of the system clock (TCS).

Direct Drive

When direct drive operation is selected (SYSCON0.CLKSEL = 11_B), the system clock is derived directly from the input clock signal CLKIN1:

$$f_{\text{SYS}} = f_{\text{IN}}$$

The frequency of f_{SYS} is the same as the frequency of f_{IN} . In this case the high and low times of f_{SYS} are determined by the duty cycle of the input clock f_{IN} .

Selecting Bypass Operation from the XTAL1¹⁾ input and using a divider factor of 1 results in a similar configuration.

Prescaler Operation

When prescaler operation is selected (SYSCON0.CLKSEL = 10_B, PLLCON0.VCOBY = 1_B), the system clock is derived either from the crystal oscillator (input clock signal XTAL1) or from the internal clock source through the output prescaler K1 (= K1DIV+1):

$$f_{\text{SYS}} = f_{\text{OSC}} / K1.$$

If a divider factor of 1 is selected, the frequency of f_{SYS} equals the frequency of f_{OSC} . In this case the high and low times of f_{SYS} are determined by the duty cycle of the input clock f_{OSC} (external or internal).

The lowest system clock frequency results from selecting the maximum value for the divider factor K1:

$$f_{\text{SYS}} = f_{\text{OSC}} / 1024.$$

Phase Locked Loop (PLL)

When PLL operation is selected (SYSCON0.CLKSEL = 10_B, PLLCON0.VCOBY = 0_B), the on-chip phase locked loop is enabled and provides the system clock. The PLL multiplies the input frequency by the factor **F** ($f_{\text{SYS}} = f_{\text{IN}} \times \mathbf{F}$).

F is calculated from the input divider P (= PDIV+1), the multiplication factor N (= NDIV+1), and the output divider K2 (= K2DIV+1):

$$(\mathbf{F} = \mathbf{N} / (\mathbf{P} \times \mathbf{K2})).$$

The input clock can be derived either from an external source at XTAL1 or from the on-chip clock source.

The PLL circuit synchronizes the system clock to the input clock. This synchronization is performed smoothly so that the system clock frequency does not change abruptly.

Adjustment to the input clock continuously changes the frequency of f_{SYS} so that it is locked to f_{IN} . The slight variation causes a jitter of f_{SYS} which in turn affects the duration of individual TCSSs.

1) Voltages on XTAL1 must comply to the core supply voltage V_{DD1} .

Electrical Parameters

The timing in the AC Characteristics refers to TCSs. Timing must be calculated using the minimum TCS possible under the given circumstances.

The actual minimum value for TCS depends on the jitter of the PLL. Because the PLL is constantly adjusting its output frequency to correspond to the input frequency (from crystal or oscillator), the accumulated jitter is limited. This means that the relative deviation for periods of more than one TCS is lower than for a single TCS (see formulas and **Figure 19**).

This is especially important for bus cycles using waitstates and for the operation of timers, serial interfaces, etc. For all slower operations and longer periods (e.g. pulse train generation or measurement, lower baudrates, etc.) the deviation caused by the PLL jitter is negligible.

The value of the accumulated PLL jitter depends on the number of consecutive VCO output cycles within the respective timeframe. The VCO output clock is divided by the output prescaler K2 to generate the system clock signal f_{SYS} . The number of VCO cycles is $K2 \times T$, where **T** is the number of consecutive f_{SYS} cycles (TCS).

The maximum accumulated jitter (long-term jitter) D_{Tmax} is defined by:

$$D_{Tmax} \text{ [ns]} = \pm(220 / (K2 \times f_{SYS}) + 4.3)$$

This maximum value is applicable, if either the number of clock cycles $T > (f_{SYS} / 1.2)$ or the prescaler value $K2 > 17$.

In all other cases for a timeframe of $T \times TCS$ the accumulated jitter D_T is determined by:

$$D_T \text{ [ns]} = D_{Tmax} \times [(1 - 0.058 \times K2) \times (T - 1) / (0.83 \times f_{SYS} - 1) + 0.058 \times K2]$$

f_{SYS} in [MHz] in all formulas.

Example, for a period of 3 TCSs @ 33 MHz and $K2 = 4$:

$$D_{max} = \pm(220 / (4 \times 33) + 4.3) = 5.97 \text{ ns (Not applicable directly in this case!)}$$

$$\begin{aligned} D_3 &= 5.97 \times [(1 - 0.058 \times 4) \times (3 - 1) / (0.83 \times 33 - 1) + 0.058 \times 4] \\ &= 5.97 \times [0.768 \times 2 / 26.39 + 0.232] \\ &= 1.7 \text{ ns} \end{aligned}$$

Example, for a period of 3 TCSs @ 33 MHz and $K2 = 2$:

$$D_{max} = \pm(220 / (2 \times 33) + 4.3) = 7.63 \text{ ns (Not applicable directly in this case!)}$$

$$\begin{aligned} D_3 &= 7.63 \times [(1 - 0.058 \times 2) \times (3 - 1) / (0.83 \times 33 - 1) + 0.058 \times 2] \\ &= 7.63 \times [0.884 \times 2 / 26.39 + 0.116] \\ &= 1.4 \text{ ns} \end{aligned}$$

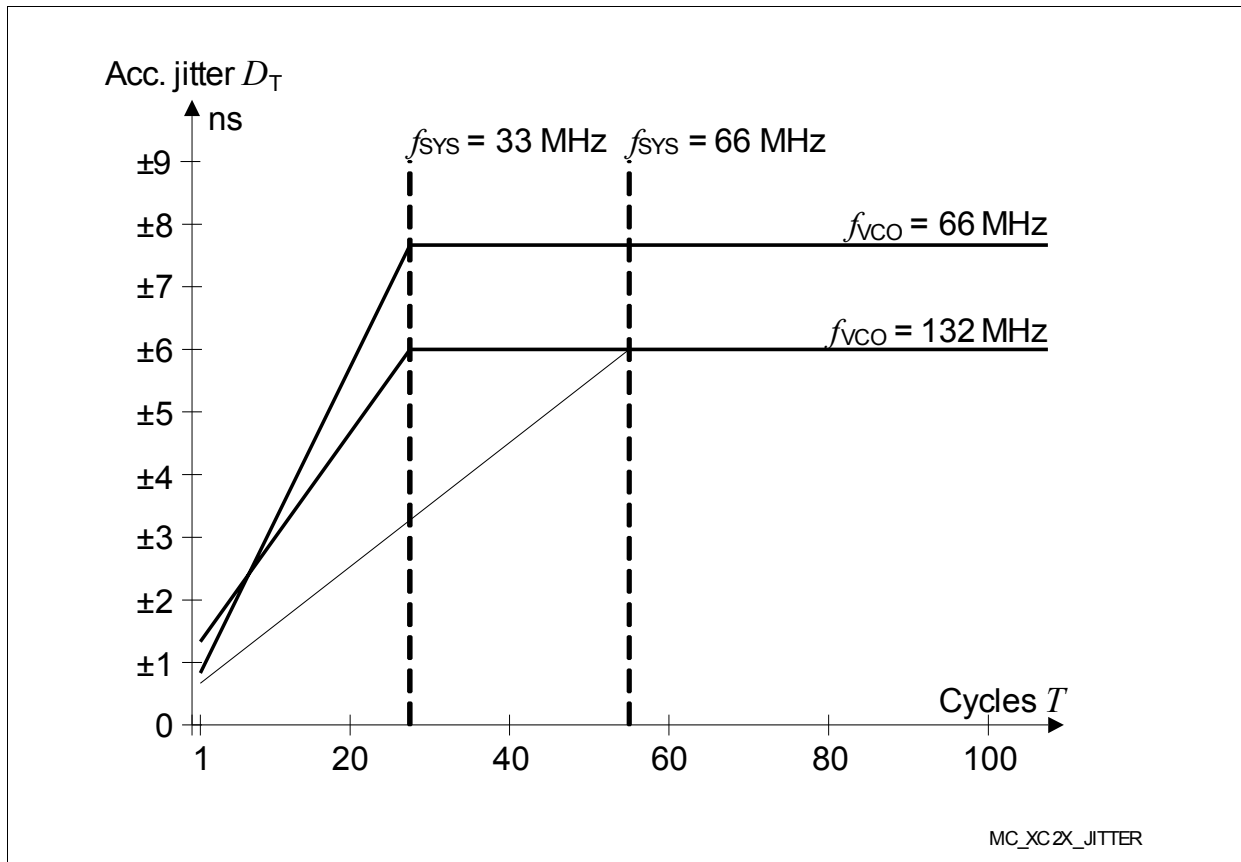

Figure 19 **Approximated Accumulated PLL Jitter**

Note: The specified PLL jitter values are valid if the capacitive load per pin does not exceed $C_L = 20$ pF (see [Table 12](#)).

The maximum peak-to-peak noise on the pad supply voltage (measured between V_{DDPB} pin 100/144 and V_{SS} pin 1) is limited to a peak-to-peak voltage of $V_{PP} = 50$ mV. This can be achieved by appropriate blocking of the supply voltage as close as possible to the supply pins and using PCB supply and ground planes.

Different frequency bands can be selected for the VCO so that the operation of the PLL can be adjusted to a wide range of input and output frequencies:

Table 25 **VCO Bands for PLL Operation¹⁾**

PLLCON0.VCOSEL	VCO Frequency Range	Base Frequency Range
00	50 ... 110 MHz	10 ... 40 MHz
01	100 ... 160 MHz	20 ... 80 MHz
1X	Reserved	

1) Not subject to production test - verified by design/characterization.

Wakeup Clock

When wakeup operation is selected ($\text{SYS_CON0.CLKSEL} = 00_{\text{B}}$), the system clock is derived from the low-frequency wakeup clock source:

$$f_{\text{SYS}} = f_{\text{WU}}$$

In this mode, a basic functionality can be maintained without requiring an external clock source and while minimizing the power consumption.

Selecting and Changing the Operating Frequency

When selecting a clock source and the clock generation method, the required parameters must be carefully written to the respective bitfields, to avoid unintended intermediate states.

Many applications change the frequency of the system clock (f_{SYS}) during operation in order to optimize system performance and power consumption. Changing the operating frequency also changes the switching currents, which influences the power supply.

To ensure proper operation of the on-chip EVRs while they generate the core voltage, the operating frequency shall only be changed in certain steps. This prevents overshoots and undershoots of the supply voltage.

To avoid the indicated problems, recommended sequences are provided which ensure the intended operation of the clock system interacting with the power system.

Please refer to the Programmer's Guide.

4.6.3 External Clock Input Parameters

These parameters specify the external clock generation for the XE167. The clock can be generated in two ways:

- By connecting a **crystal or ceramic resonator** to pins XTAL1/XTAL2.
- By supplying an **external clock signal**. This clock signal can be supplied either to pin XTAL1 (core voltage domain) or to pin CLKIN1 (IO voltage domain).

If connected to CLKIN1, the input signal must reach the defined input levels V_{IL} and V_{IH} . In connected to XTAL1, a minimum amplitude V_{AX1} (peak-to-peak voltage) is sufficient for the operation of the on-chip oscillator.

Note: The given clock timing parameters ($t_1 \dots t_4$) are only valid for an external clock input signal.

Table 26 External Clock Input Characteristics
(Operating Conditions apply)

Parameter	Symbol	Limit Values			Unit	Note / Test Condition
		Min.	Typ.	Max.		
Input voltage range limits for signal on XTAL1	V_{IX1} SR	$-1.7 + V_{DDI}$	–	1.7	V	1)
Input voltage (amplitude) on XTAL1	V_{AX1} SR	$0.3 \times V_{DDI}$	–	–	V	Peak-to-peak voltage ²⁾
XTAL1 input current	I_{IL} CC	–	–	± 20	μA	$0 V < V_{IN} < V_{DDI}$
Oscillator frequency	f_{OSC} CC	4	–	40	MHz	Clock signal
		4	–	16	MHz	Crystal or Resonator
High time	t_1 SR	6	–	–	ns	
Low time	t_2 SR	6	–	–	ns	
Rise time	t_3 SR	–	8	8	ns	
Fall time	t_4 SR	–	8	8	ns	

1) Overload conditions must not occur on pin XTAL1.

2) The amplitude voltage V_{AX1} refers to the offset voltage V_{OFF} . This offset voltage must be stable during the operation and the resulting voltage peaks must remain within the limits defined by V_{IX1} .

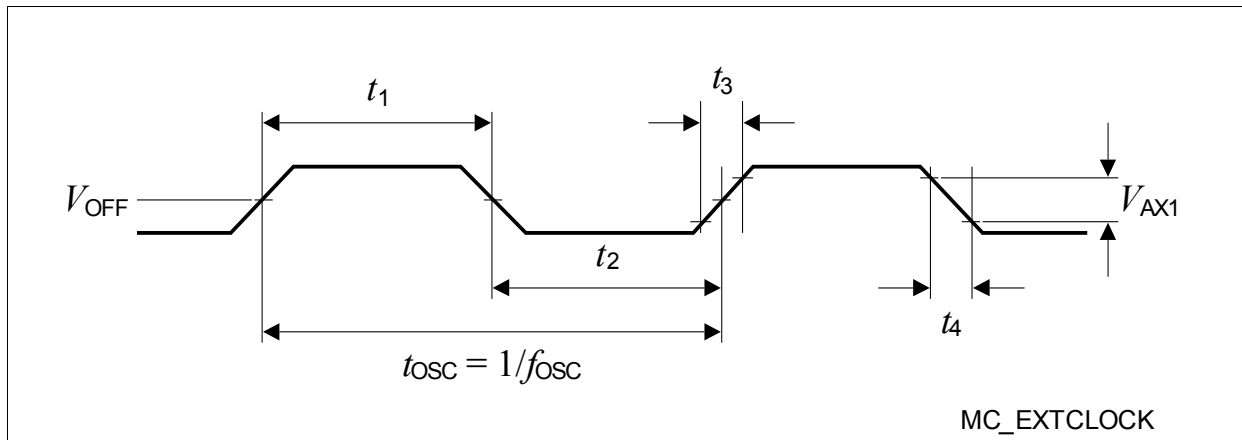

Figure 20 External Clock Drive XTAL1

Note: For crystal/resonator operation, it is strongly recommended to measure the oscillation allowance (negative resistance) in the final target system (layout) to determine the optimum parameters for oscillator operation.

Please refer to the limits specified by the crystal/resonator supplier.

4.6.4 External Bus Timing

The following parameters specify the behavior of the XE167 bus interface.

Table 27 CLKOUT Reference Signal

Parameter	Symbol	Limits	Limits		Unit	Note / Test Condition
			Min.	Max.		
CLKOUT cycle time	t_5 CC	40/25/12.5 ¹⁾		ns		
CLKOUT high time	t_6 CC	3	–	ns		
CLKOUT low time	t_7 CC	3	–	ns		
CLKOUT rise time	t_8 CC	–	3	ns		
CLKOUT fall time	t_9 CC	–	3	ns		

1) The CLKOUT cycle time is influenced by the PLL jitter (given values apply to $f_{SYS} = 25/40/80$ MHz). For longer periods the relative deviation decreases (see PLL deviation formula).

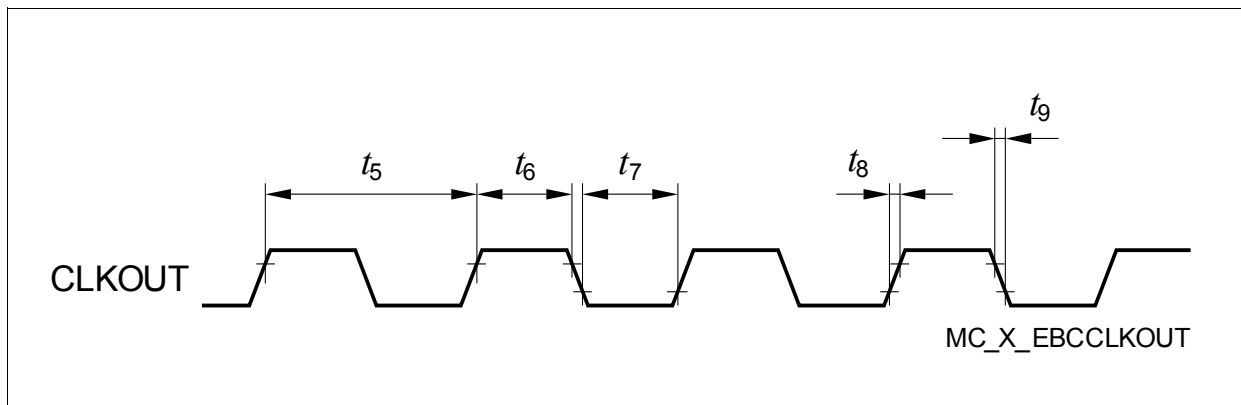

Figure 21 CLKOUT Signal Timing

Note: The term CLKOUT refers to the reference clock output signal which is generated by selecting f_{SYS} as the source signal for the clock output signal EXTCLK on pin P2.8 and by enabling the high-speed clock driver on this pin.

Variable Memory Cycles

External bus cycles of the XE167 are executed in five consecutive cycle phases (AB, C, D, E, F). The duration of each cycle phase is programmable (via the TCONCSx registers) to adapt the external bus cycles to the respective external module (memory, peripheral, etc.).

The duration of the access phase can optionally be controlled by the external module using the READY handshake input.

This table provides a summary of the phases and the ranges for their length.

Table 28 Programmable Bus Cycle Phases (see timing diagrams)

Bus Cycle Phase	Parameter	Valid Values	Unit
Address setup phase, the standard duration of this phase (1 ... 2 TCS) can be extended by 0 ... 3 TCS if the address window is changed	tpAB	1 ... 2 (5)	TCS
Command delay phase	tpC	0 ... 3	TCS
Write Data setup/MUX Tristate phase	tpD	0 ... 1	TCS
Access phase	tpE	1 ... 32	TCS
Address/Write Data hold phase	tpF	0 ... 3	TCS

Note: The bandwidth of a parameter (from minimum to maximum value) covers the whole operating range (temperature, voltage) as well as process variations. Within a given device, however, this bandwidth is smaller than the specified range. This is also due to interdependencies between certain parameters. Some of these interdependencies are described in additional notes (see standard timing).

**Table 29 External Bus Cycle Timing for Upper Voltage Range
(Operating Conditions apply)**

Parameter	Symbol	Limits			Unit	Note
		Min.	Typ.	Max.		
Output valid delay for: \overline{RD} , $\overline{WR(L/H)}$	t_{10} CC	–		13	ns	
Output valid delay for: \overline{BHE} , ALE	t_{11} CC	–		13	ns	
Output valid delay for: A23 ... A16, A15 ... A0 (on P0/P1)	t_{12} CC	–		14	ns	
Output valid delay for: A15 ... A0 (on P2/P10)	t_{13} CC	–		14	ns	
Output valid delay for: \overline{CS}	t_{14} CC	–		13	ns	
Output valid delay for: D15 ... D0 (write data, MUX-mode)	t_{15} CC	–		14	ns	
Output valid delay for: D15 ... D0 (write data, DEMUX-mode)	t_{16} CC	–		14	ns	
Output hold time for: \overline{RD} , $\overline{WR(L/H)}$	t_{20} CC	0		8	ns	
Output hold time for: \overline{BHE} , ALE	t_{21} CC	0		8	ns	
Output hold time for: A23 ... A16, A15 ... A0 (on P2/P10)	t_{23} CC	0		8	ns	
Output hold time for: \overline{CS}	t_{24} CC	0		8	ns	
Output hold time for: D15 ... D0 (write data)	t_{25} CC	0		8	ns	
Input setup time for: READY, D15 ... D0 (read data)	t_{30} SR	18		–	ns	
Input hold time for: READY, D15 ... D0 (read data) ¹⁾	t_{31} SR	-4		–	ns	

1) Read data are latched with the same internal clock edge that triggers the address change and the rising edge of \overline{RD} . Address changes before the end of \overline{RD} have no impact on (demultiplexed) read cycles. Read data can change after the rising edge of \overline{RD} .

**Table 30 External Bus Cycle Timing for Lower Voltage Range
(Operating Conditions apply)**

Parameter	Symbol	Limits			Unit	Note
		Min.	Typ.	Max.		
Output valid delay for: \overline{RD} , $\overline{WR(L/H)}$	t_{10} CC	–		20	ns	
Output valid delay for: \overline{BHE} , ALE	t_{11} CC	–		20	ns	
Output valid delay for: A23 ... A16, A15 ... A0 (on P0/P1)	t_{12} CC	–		22	ns	
Output valid delay for: A15 ... A0 (on P2/P10)	t_{13} CC	–		22	ns	
Output valid delay for: \overline{CS}	t_{14} CC	–		20	ns	
Output valid delay for: D15 ... D0 (write data, MUX-mode)	t_{15} CC	–		21	ns	
Output valid delay for: D15 ... D0 (write data, DEMUX-mode)	t_{16} CC	–		21	ns	
Output hold time for: \overline{RD} , $\overline{WR(L/H)}$	t_{20} CC	0		10	ns	
Output hold time for: \overline{BHE} , ALE	t_{21} CC	0		10	ns	
Output hold time for: A23 ... A16, A15 ... A0 (on P2/P10)	t_{23} CC	0		10	ns	
Output hold time for: \overline{CS}	t_{24} CC	0		10	ns	
Output hold time for: D15 ... D0 (write data)	t_{25} CC	0		10	ns	
Input setup time for: READY, D15 ... D0 (read data)	t_{30} SR	29		–	ns	
Input hold time for: READY, D15 ... D0 (read data) ¹⁾	t_{31} SR	-6		–	ns	

1) Read data are latched with the same internal clock edge that triggers the address change and the rising edge of \overline{RD} . Address changes before the end of \overline{RD} have no impact on (demultiplexed) read cycles. Read data can change after the rising edge of \overline{RD} .

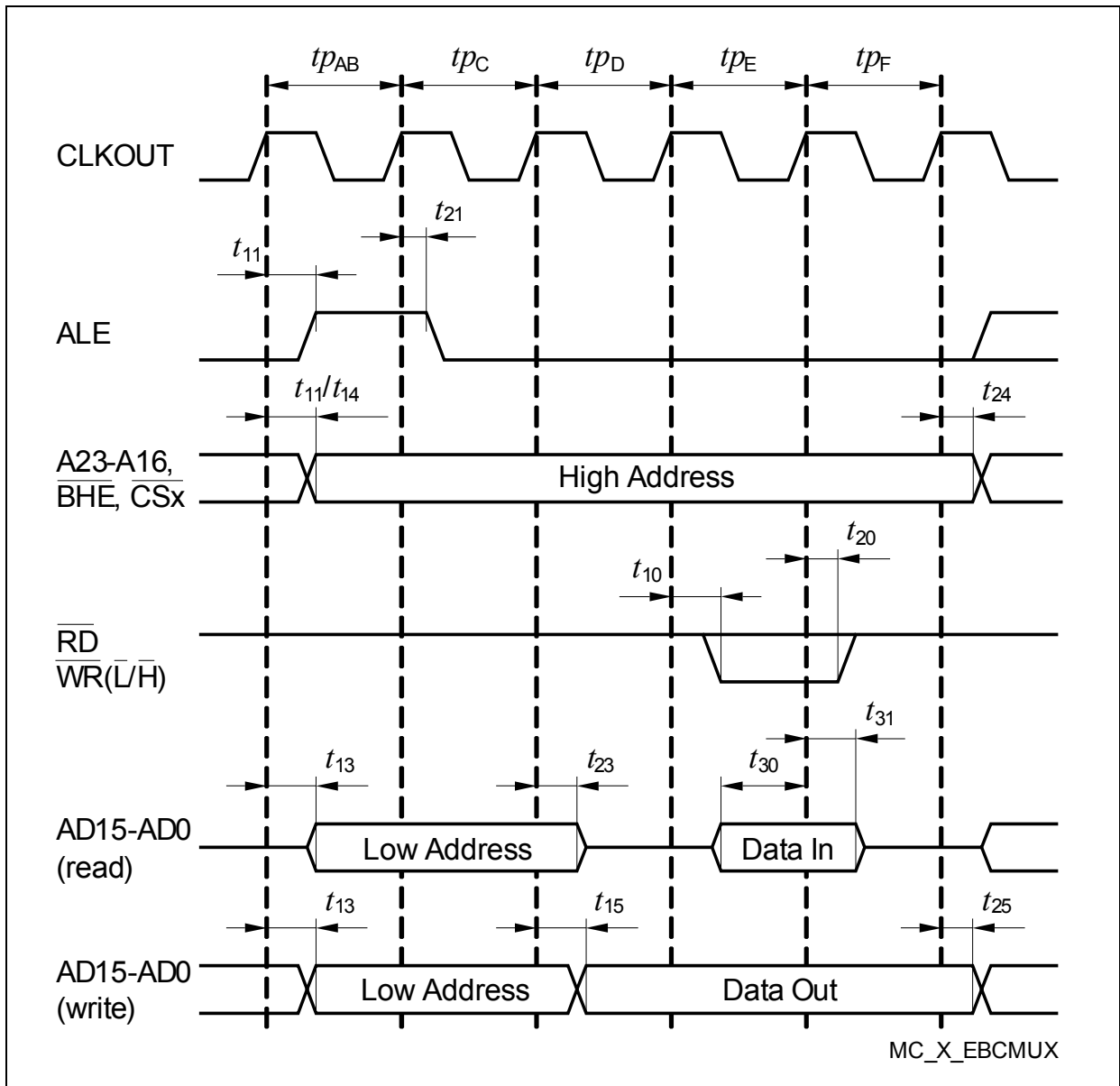

Figure 22 Multiplexed Bus Cycle

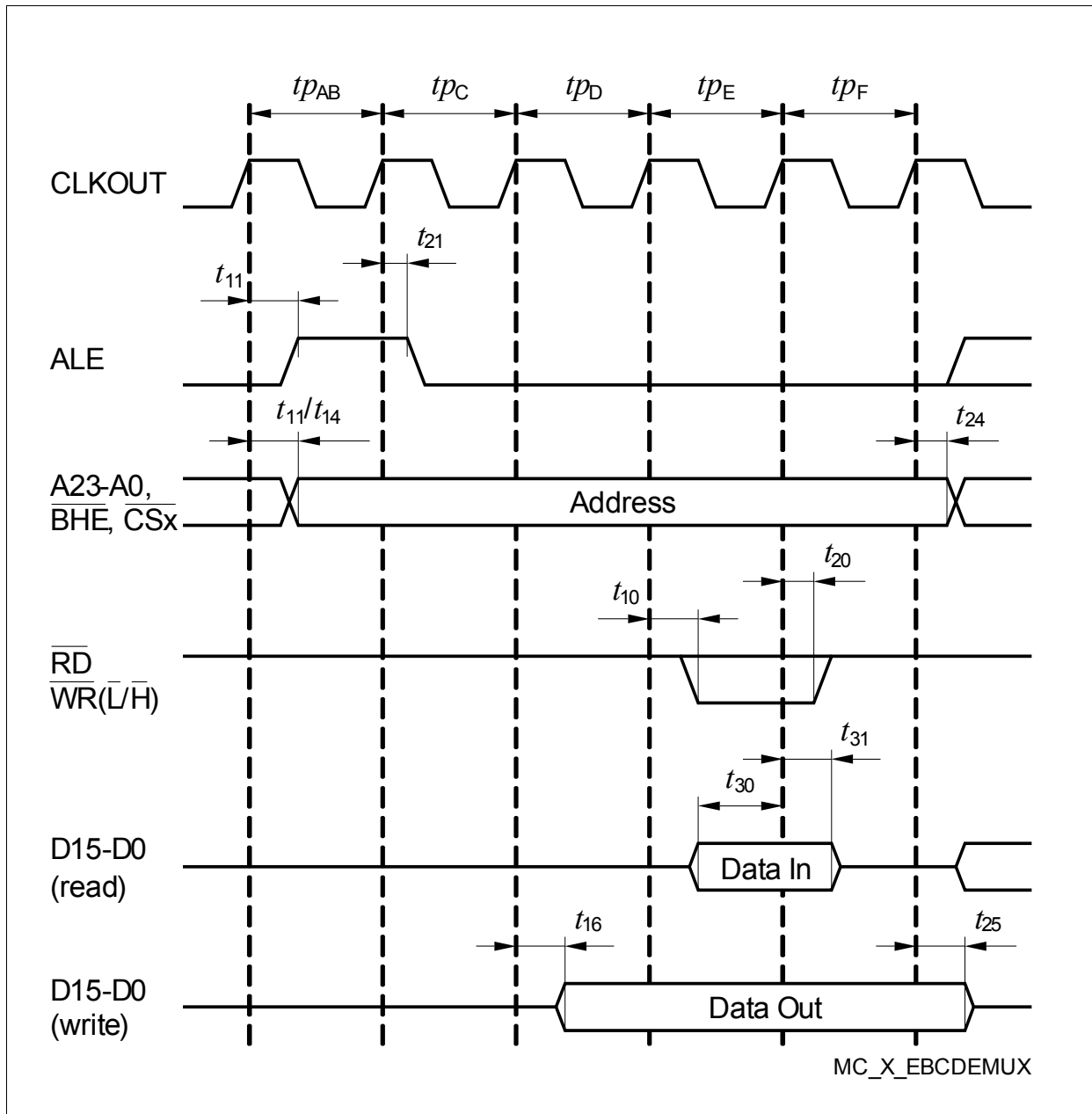

Figure 23 Demultiplexed Bus Cycle

Bus Cycle Control with the READY Input

The duration of an external bus cycle can be controlled by the external circuit using the READY input signal. The polarity of this input signal can be selected.

Synchronous READY permits the shortest possible bus cycle but requires the input signal to be synchronous to the reference signal CLKOUT.

An asynchronous READY signal puts no timing constraints on the input signal but incurs a minimum of one waitstate due to the additional synchronization stage. The minimum duration of an asynchronous READY signal for safe synchronization is one CLKOUT period plus the input setup time.

An active READY signal can be deactivated in response to the trailing (rising) edge of the corresponding command (\overline{RD} or \overline{WR}).

If the next bus cycle is controlled by READY, an active READY signal must be disabled before the first valid sample point in the next bus cycle. This sample point depends on the programmed phases of the next cycle.

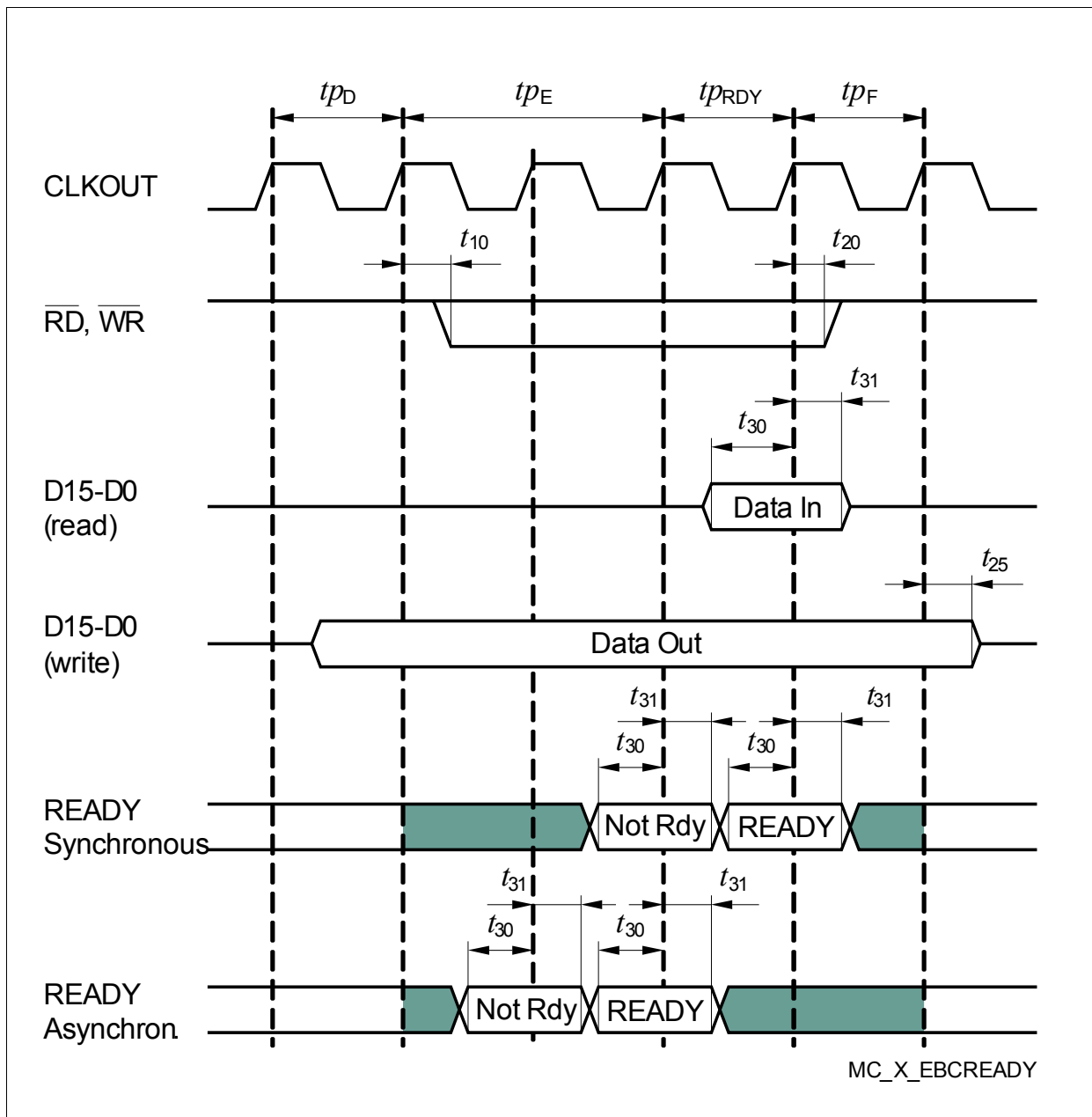

Figure 24 READY Timing

Note: If the READY input is sampled inactive at the indicated sampling point ("Not Rdy") a READY-controlled waitstate is inserted (tp_{RDY}), sampling the READY input active at the indicated sampling point ("Ready") terminates the currently running bus cycle. Note the different sampling points for synchronous and asynchronous READY. This example uses one mandatory waitstate (see tp_E) before the READY input value is used.

External Bus Arbitration

If the arbitration signals are enabled, the XE167 makes its external resources available in response to an arbitration request.

**Table 31 Bus Arbitration Timing for Upper Voltage Range
(Operating Conditions apply)**

Parameter	Symbol	Limits			Unit	Note
		Min.	Typ.	Max.		
Input setup time for: HOLD input	t_{40} SR	18		–	ns	
Output delay rising edge for: HLDA, BREQ	t_{41} CC	0		13	ns	
Output delay falling edge for: HLDA	t_{42} CC	1		14	ns	

**Table 32 Bus Arbitration Timing for Lower Voltage Range
(Operating Conditions apply)**

Parameter	Symbol	Limits			Unit	Note
		Min.	Typ.	Max.		
Input setup time for: HOLD input	t_{40} SR	28		–	ns	
Output delay rising edge for: HLDA, BREQ	t_{41} CC	0		19	ns	
Output delay falling edge for: HLDA	t_{42} CC	1		21	ns	

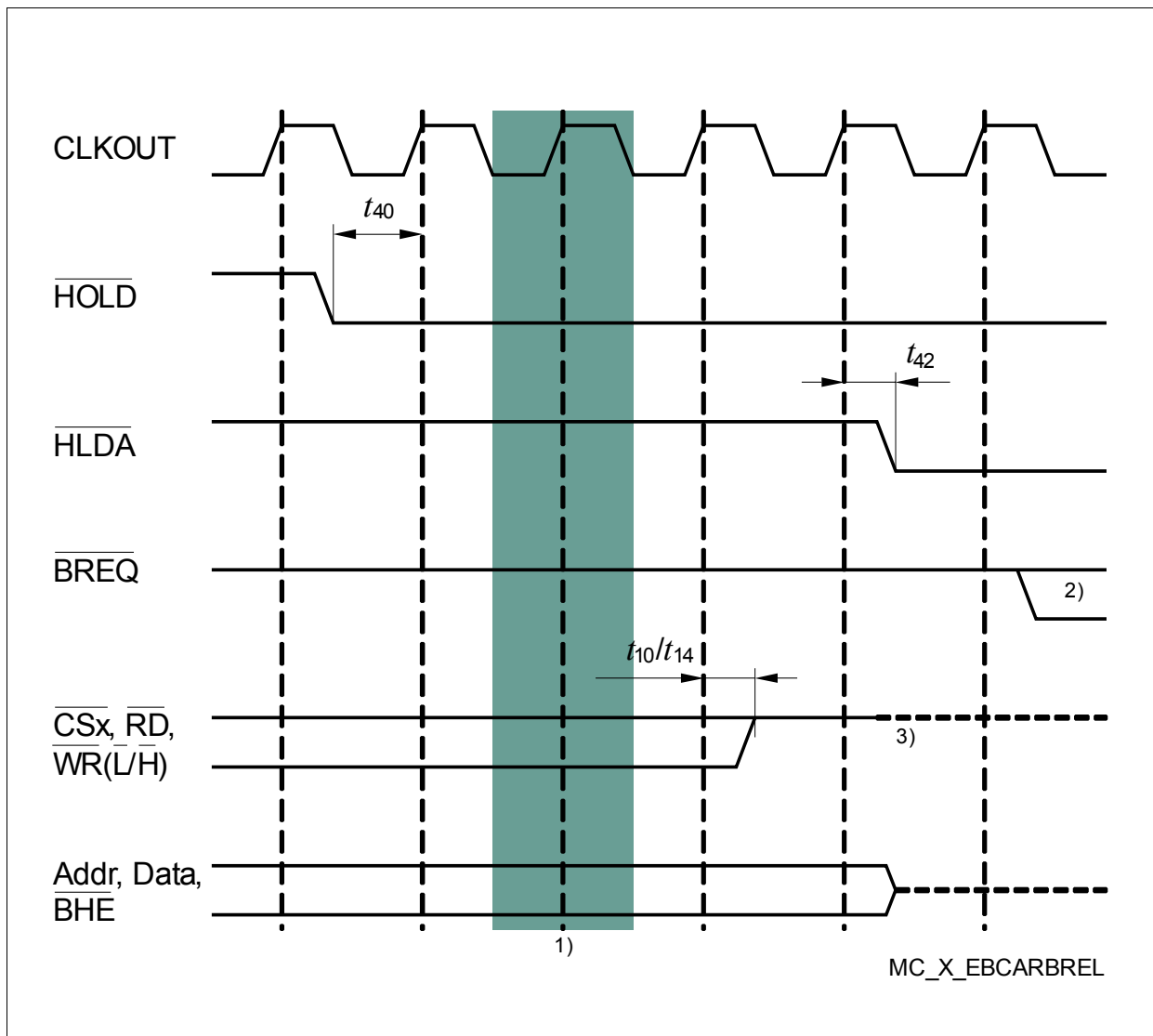

Figure 25 External Bus Arbitration, Releasing the Bus

Notes

1. The XE167 completes the currently running bus cycle before granting bus access.
2. This is the first possibility for BREQ to get active.
3. The control outputs will be resistive high (pull-up) after being driven inactive (ALE will be low).

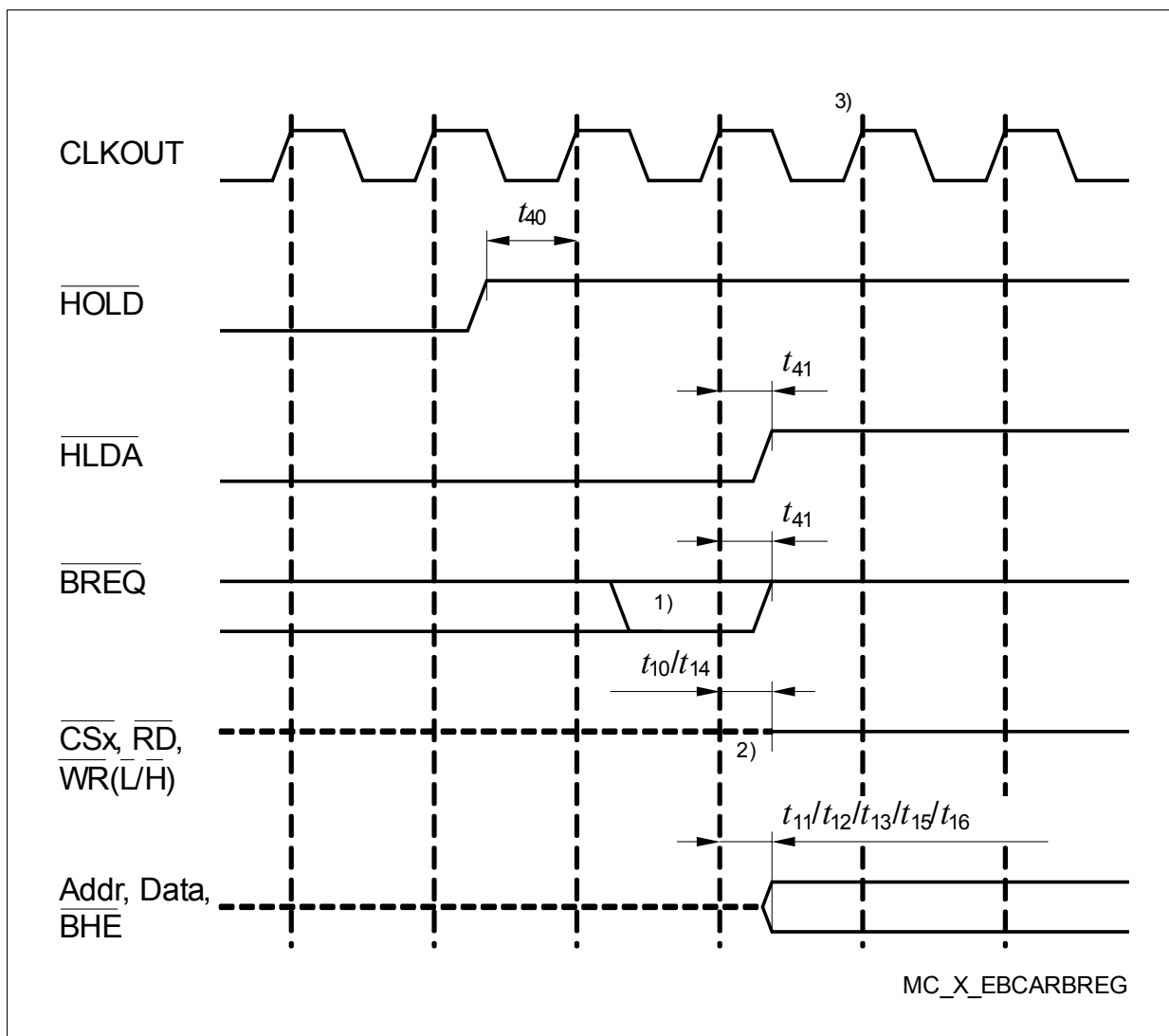

Figure 26 External Bus Arbitration, Regaining the Bus

Notes

1. This is the last chance for \overline{BREQ} to trigger the indicated regain sequence. Even if \overline{BREQ} is activated earlier, the regain sequence is initiated by \overline{HOLD} going high. Please note that \overline{HOLD} may also be deactivated without the XE167 requesting the bus.
2. The control outputs will be resistive high (pull-up) before being driven inactive (ALE will be low).
3. The next XE167-driven bus cycle may start here.

4.6.5 Synchronous Serial Interface Timing

The following parameters are applicable for a USIC channel operated in SSC mode.

Note: These parameters are not subject to production test but verified by design and/or characterization.

Table 33 SSC Master/Slave Mode Timing for Upper Voltage Range (Operating Conditions apply), $C_L = 50$ pF

Parameter	Symbol	Values			Unit	Note / Test Condition
		Min.	Typ.	Max.		
Master Mode Timing						
Slave select output SELO active to first SCLKOUT transmit edge	t_1 CC	0	–	1)	ns	2)
Slave select output SELO inactive after last SCLKOUT receive edge	t_2 CC	$0.5 \times t_{BIT}$	–	3)	ns	
Transmit data output valid time	t_3 CC	-6	–	13	ns	
Receive data input setup time to SCLKOUT receive edge	t_4 SR	31	–	–	ns	
Data input DX0 hold time from SCLKOUT receive edge	t_5 SR	-7	–	–	ns	
Slave Mode Timing						
Select input DX2 setup to first clock input DX1 transmit edge	t_{10} SR	7	–	–	ns	4)
Select input DX2 hold after last clock input DX1 receive edge	t_{11} SR	5	–	–	ns	7)
Data input DX0 setup time to clock input DX1 receive edge	t_{12} SR	7	–	–	ns	7)
Data input DX0 hold time from clock input DX1 receive edge	t_{13} SR	5	–	–	ns	7)
Data output DOUT valid time	t_{14} CC	8	–	29	ns	7)

1) The maximum value further depends on the settings for the slave select output leading delay.

2) $t_{SYS} = 1/f_{SYS}$ (= 12.5 ns @ 80 MHz)

3) The maximum value depends on the settings for the slave select output trailing delay and for the shift clock output delay.

4) These input timings are valid for asynchronous input signal handling of slave select input, shift clock input, and receive data input (bits DXnCR.DSEN = 0).

Table 34 SSC Master/Slave Mode Timing for Lower Voltage Range (Operating Conditions apply), $C_L = 50$ pF

Parameter	Symbol	Values			Unit	Note / Test Condition
		Min.	Typ.	Max.		
Master Mode Timing						
Slave select output SELO active to first SCLKOUT transmit edge	t_1 CC	0	–	1)	ns	2)
Slave select output SELO inactive after last SCLKOUT receive edge	t_2 CC	$0.5 \times t_{BIT}$	–	3)	ns	2)
Transmit data output valid time	t_3 CC	-13	–	16	ns	
Receive data input setup time to SCLKOUT receive edge	t_4 SR	48	–	–	ns	
Data input DX0 hold time from SCLKOUT receive edge	t_5 SR	-11	–	–	ns	
Slave Mode Timing						
Select input DX2 setup to first clock input DX1 transmit edge	t_{10} SR	12	–	–	ns	4)
Select input DX2 hold after last clock input DX1 receive edge	t_{11} SR	8	–	–	ns	7)
Data input DX0 setup time to clock input DX1 receive edge	t_{12} SR	12	–	–	ns	7)
Data input DX0 hold time from clock input DX1 receive edge	t_{13} SR	8	–	–	ns	7)
Data output DOUT valid time	t_{14} CC	11	–	44	ns	7)

1) The maximum value further depends on the settings for the slave select output leading delay.

2) $t_{SYS} = 1/f_{SYS}$ (= 12.5ns @ 80 MHz)

3) The maximum value depends on the settings for the slave select output trailing delay and for the shift clock output delay.

4) These input timings are valid for asynchronous input signal handling of slave select input, shift clock input, and receive data input (bits DXnCR.DSEN = 0).

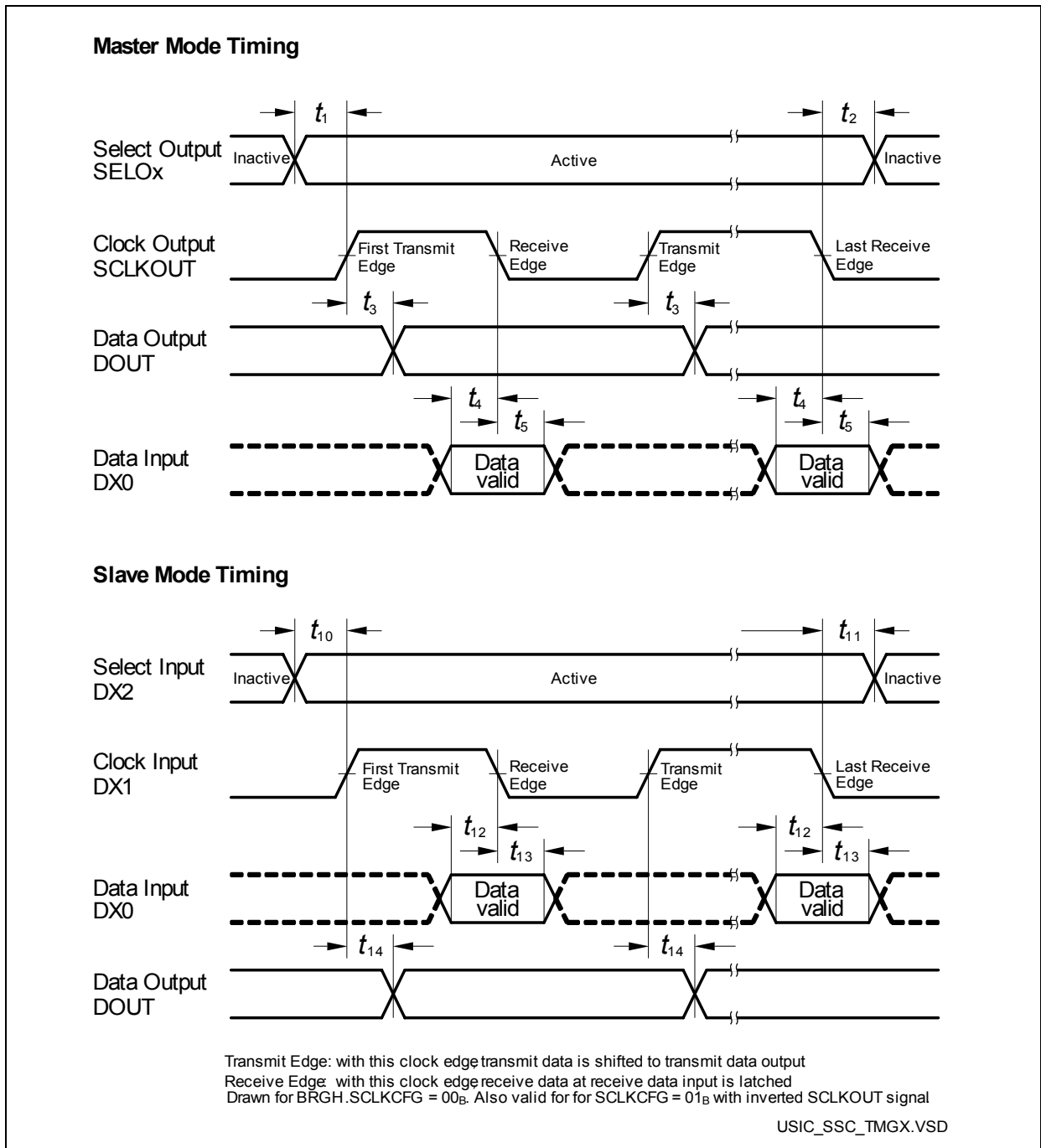

Figure 27 USIC - SSC Master/Slave Mode Timing

Note: This timing diagram shows a standard configuration where the slave select signal is low-active and the serial clock signal is not shifted and not inverted.

4.6.6 JTAG Interface Timing

The following parameters are applicable for communication through the JTAG debug interface. The JTAG module is fully compliant with IEEE1149.1-2000.

Note: These parameters are not subject to production test but verified by design and/or characterization.

**Table 35 JTAG Interface Timing Parameters
(Operating Conditions apply)**

Parameter	Symbol	Values			Unit	Note / Test Condition
		Min.	Typ.	Max.		
TCK clock period	t_1 SR	60	50	–	ns	–
TCK high time	t_2 SR	16	–	–	ns	–
TCK low time	t_3 SR	16	–	–	ns	–
TCK clock rise time	t_4 SR	–	–	8	ns	–
TCK clock fall time	t_5 SR	–	–	8	ns	–
TDI/TMS setup to TCK rising edge	t_6 SR	6	–	–	ns	–
TDI/TMS hold after TCK rising edge	t_7 SR	6	–	–	ns	–
TDO valid after TCK falling edge ¹⁾	t_8 CC	–	–	30	ns	$C_L = 50$ pF
	t_8 CC	10	–	–	ns	$C_L = 20$ pF
TDO high imped. to valid from TCK falling edge ¹⁾²⁾	t_9 CC	–	–	30	ns	$C_L = 50$ pF
TDO valid to high imped. from TCK falling edge ¹⁾	t_{10} CC	–	–	30	ns	$C_L = 50$ pF

1) The falling edge on TCK is used to generate the TDO timing.

2) The setup time for TDO is given implicitly by the TCK cycle time.

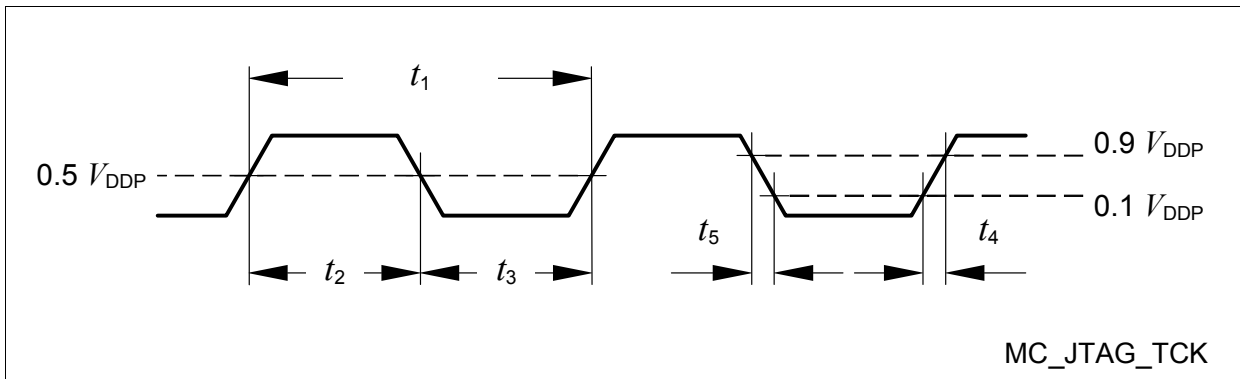

Figure 28 Test Clock Timing (TCK)

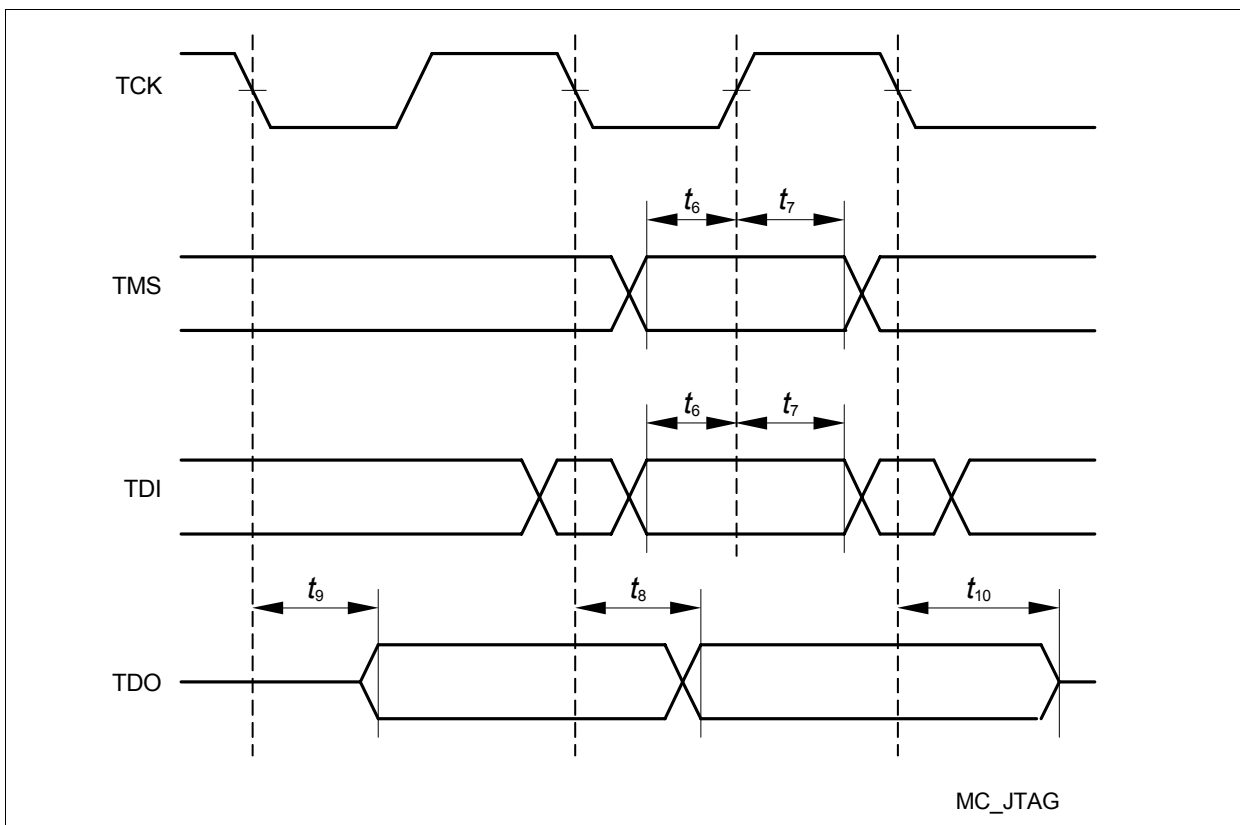

Figure 29 JTAG Timing

5 Package and Reliability

In addition to the electrical parameters, the following specifications ensure proper integration of the XE167 into the target system.

5.1 Packaging

These parameters specify the packaging rather than the silicon.

Table 36 Package Parameters (PG-LQFP-144-4)

Parameter	Symbol	Limit Values		Unit	Notes
		Min.	Max.		
Exposed Pad Dimension	$E_x \times E_y$	–	6.5×6.5	mm	–
Power Dissipation	P_{DISS}	–	1.0	W	–
Thermal resistance Junction-Ambient	$R_{\Theta JA}$	–	45	K/W	No thermal via ¹⁾
			36	K/W	4-layer, no pad ²⁾
			22	K/W	4-layer, pad ³⁾

1) Device mounted on a 2-layer JEDEC board (according to JESD 51-3) or a 4-layer board without thermal vias; exposed pad not soldered.

2) Device mounted on a 4-layer JEDEC board (according to JESD 51-7) with thermal vias; exposed pad not soldered.

3) Device mounted on a 4-layer JEDEC board (according to JESD 51-7) with thermal vias; exposed pad soldered to the board.

5.2 Thermal Considerations

When operating the XE167 in a system, the total heat generated in the chip must be dissipated to the ambient environment to prevent overheating and the resulting thermal damage.

The maximum heat that can be dissipated depends on the package and its integration into the target board. The “Thermal resistance $R_{\Theta JA}$ ” quantifies these parameters. The power dissipation must be limited so that the average junction temperature does not exceed 125 °C.

The difference between junction temperature and ambient temperature is determined by $\Delta T = (P_{INT} + P_{IOSTAT} + P_{IODYN}) \times R_{\Theta JA}$

The internal power consumption is defined as

$$P_{INT} = V_{DDP} \times I_{DDP} \text{ (see Section 4.2.3).}$$

The static external power consumption caused by the output drivers is defined as

$$P_{IOSTAT} = \Sigma((V_{DDP} - V_{OH}) \times I_{OH}) + \Sigma(V_{OL} \times I_{OL})$$

The dynamic external power consumption caused by the output drivers (P_{IODYN}) depends on the capacitive load connected to the respective pins and their switching frequencies.

If the total power dissipation for a given system configuration exceeds the defined limit, countermeasures must be taken to ensure proper system operation:

- Reduce V_{DDP} , if possible in the system
- Reduce the system frequency
- Reduce the number of output pins
- Reduce the load on active output drivers

www.infineon.com



Published by Infineon Technologies AG

Looking for pricing, stock, or lifecycle information?

Click below to explore more details on WIN SOURCE:

-  [View XE167F96F66LACFXUMA1 on WIN SOURCE](#)
-  [Infineon Technologies Information](#)

Optimize Your Supply Chain with WIN SOURCE Solutions

-  Global Sourcing Solution
-  Obsolete Management
-  Cost Control Management
-  Shortage Management
-  Alternative Solution
-  Excess Inventory Management