



**THE DATASHEET OF  
LT4293HDD#PBF**



# LTPoE++/IEEE 802.3bt PD Interface Controller

## FEATURES

- LTPoE++®/IEEE 802.3bt Powered Device (PD) Controller
- Supports Up to 90W PDs
- Distinguishes Between LTPoE++ and IEEE 802.3bt PSEs
- 5-Event Classification Sensing
- Superior Surge Protection (100V Absolute Maximum)
- Wide Junction Temperature Range (−40°C to 125°C)
- Overtemperature Protection
- Integrated Signature Resistor
- External Hot Swap N-Channel MOSFET for Lowest Power Dissipation and Highest System Efficiency
- Configurable Aux Power Support as Low as 9V
- Pin Compatible with LT4275A/B/C and LT4294
- Available in 10-Lead MSOP and 3mm × 3mm DFN Packages

## APPLICATIONS

- High Power Wireless Data Systems
- Outdoor Security Camera Equipment
- Commercial and Public Information Displays
- High Temperature Industrial Applications

## DESCRIPTION

The **LT<sup>®</sup>4293** is an LTPoE++/IEEE 802.3af/at/bt-compliant powered device (PD) interface controller. The  $\overline{T2P}$  output distinguishes between LTPoE++ and IEEE 802.3bt power sourcing equipment (PSE) during mutual identification and negotiation of available power.

The LT4293 utilizes an external, low  $R_{DS(ON)}$ , N-channel, hot swap MOSFET and supports the LT4320/LT4321 ideal bridges, to extend the end-to-end power delivery efficiency and eliminate costly heat sinks. The LT4293 also includes a power good output, onboard signature resistor, undervoltage lockout, and thermal protection. Start-up inrush current is adjustable with an external capacitor. Auxiliary power override is supported as low as 9V with the AUX pin.

The LT4293 can be configured to support all possible LTPoE++, 802.3bt, 802.3at and 802.3af power levels with external component changes. Pin-for-pin compatibility with the LT4275 and LT4294 family of PD Interface Controllers enables easy migration between LTPoE++ PDs and IEEE 802.3bt-compliant PDs.

All registered trademarks and trademarks are the property of their respective owners.

## TYPICAL APPLICATION

LTPoE++/IEEE 802.3bt Single-Signature Powered Device Interface

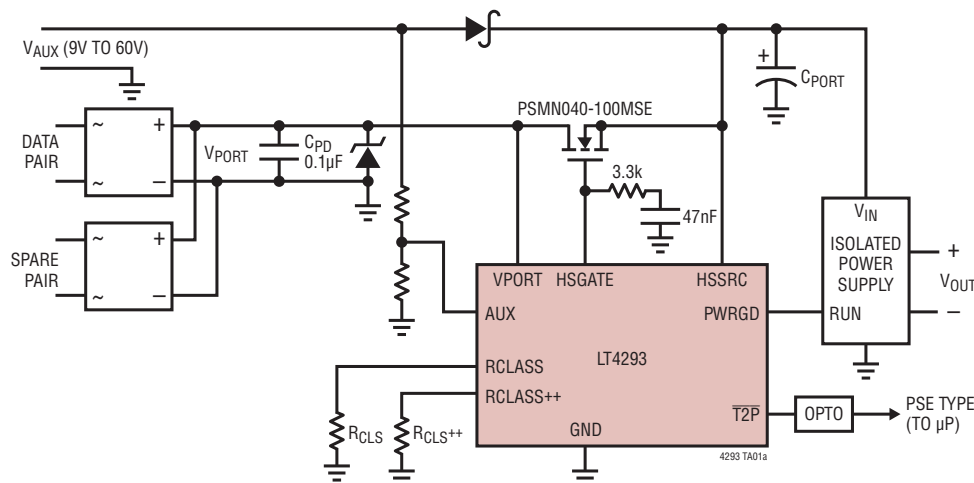

CLASS	SINGLE-SIGNATURE POWER CLASSIFICATION (AT PD INPUT)	
	LTPoE++	IEEE 802.3bt
0	13W	13W
1	3.84W	3.84W
2	6.49W	6.49W
3	13W	13W
4	25.5W	25.5W
5	38.7W	40W
6	52.7W	51W
7	70W	62W
8	90W	71.3W

# LT4293

## ABSOLUTE MAXIMUM RATINGS

(Notes 1, 3)

VPORT, HSSRC Voltages .....	-0.3V to 100V
HSGATE Current.....	±20mA
RCLASS, RCLASS++ Voltages.....	-0.3V to 8V (and ≤ VPORT)
AUX Current.....	±1.4mA
T2P, PWRGD Voltage .....	-0.3V to 100V
T2P, PWRGD Current .....	5mA

Operating Junction Temperature Range (Note 4)	
LT4293I.....	-40°C to 85°C
LT4293H .....	-40°C to 125°C
Storage Temperature Range .....	-65°C to 150°C
Lead Temperature (Soldering, 10 sec.).....	300°C (MSOP Only)

## PIN CONFIGURATION

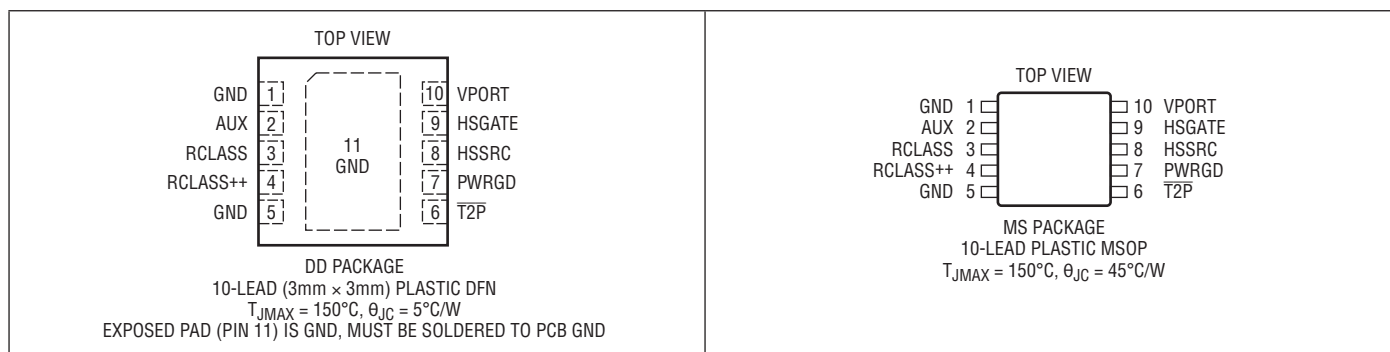

## ORDER INFORMATION

TUBE	TAPE AND REEL	PART MARKING*	PACKAGE DESCRIPTION	TEMPERATURE RANGE
LT4293IDD#PBF	LT4293IDD#TRPBF	LHJX	10-Lead (3mm × 3mm) Plastic DFN	-40°C to 85°C
LT4293HDD#PBF	LT4293HDD#TRPBF	LHJX	10-Lead (3mm × 3mm) Plastic DFN	-40°C to 125°C
LT4293IMS#PBF	LT4293IMS#TRPBF	LTHJY	10-Lead Plastic MSOP	-40°C to 85°C
LT4293HMS#PBF	LT4293HMS#TRPBF	LTHJY	10-Lead Plastic MSOP	-40°C to 125°C

Contact the factory for parts specified with wider operating temperature ranges. \*The temperature grade is identified by a label on the shipping container.

[Tape and reel specifications](#). Some packages are available in 500 unit reels through designated sales channels with #TRMPBF suffix.

## ELECTRICAL CHARACTERISTICS

The ● denotes the specifications which apply over the full operating temperature range, otherwise specifications are at  $T_A = 25^\circ\text{C}$ . (Note 3)

SYMBOL	PARAMETER	CONDITIONS	MIN	TYP	MAX	UNITS
	VPORT Operating Input Voltage	At VPORT Pin ●			60	V
$V_{SIG}$	VPORT Signature Range	At VPORT Pin ●	1.5		10	V
$V_{CLASS}$	VPORT Classification Range	At VPORT Pin ●	12.5		21	V
$V_{MARK}$	VPORT Mark Range	At VPORT Pin, Preceded by $V_{CLASS}$ ●	5.6		10	V
	VPORT Aux Mode Range	At VPORT Pin, $AUX > V_{AUXT}$ ●	8		60	V
	Signature/Class Hysteresis Window	●	1.0			V

Rev. 0

**ELECTRICAL CHARACTERISTICS** The ● denotes the specifications which apply over the full operating temperature range, otherwise specifications are at T<sub>A</sub> = 25°C. (Note 3)

SYMBOL	PARAMETER	CONDITIONS	MIN	TYP	MAX	UNITS
V <sub>RESET</sub>	Reset Threshold	At V <sub>PORT</sub> Pin, Preceded by V <sub>CLASS</sub>	● 2.6		5.6	V
V <sub>HSON</sub>	Hot Swap Turn-On Voltage		●	35	37	V
V <sub>HSOFF</sub>	Hot Swap Turn-Off Voltage		● 30	31		V
	Hot Swap On/Off Hysteresis Window		● 3			V

**Supply Current**

	Supply Current	V <sub>VPORT</sub> = V <sub>HSSRC</sub> = 57V	●		2	mA	
	Supply Current During Classification	V <sub>VPORT</sub> = 17.5V, RCLASS and RCLASS++ Open	●	0.4	0.7	0.9	mA
	Supply Current During Mark Event	V <sub>VPORT</sub> = V <sub>MARK</sub> After 1st Classification Event	●	0.5		2.2	mA

**Detection and Classification Signature**

	Detection Signature Resistance	V <sub>SIG</sub> (Note 2)	●	23.7	24.4	25.2	kΩ
	Resistance During Mark Event	V <sub>MARK</sub> (Note 2)	●	5.8	8.3	11	kΩ
	RCLASS/RCLASS++ Operating Voltage	-10mA ≥ I <sub>RCLASS</sub> ≥ -36mA, V <sub>CLASS</sub>	●	1.32	1.40	1.43	V
	Classification Signature Stability Time	V <sub>VPORT</sub> Step to 17.5V, 34.8Ω from RCLASS or RCLASS++ to GND	●			2	ms

**Analog/Digital Interface**

V <sub>AUXT</sub>	AUX Threshold		●	6.1	6.3	6.5	V
I <sub>AUXH</sub>	AUX Pin Hysteresis Current	V <sub>AUX</sub> = 6.1V	●	3.2	5	7	μA
	T <sub>2P</sub> Output Low	1mA Load	●			0.8	V
	PWRGD Output Low	1mA Load	●			0.8	V
	PWRGD Leakage Current	V <sub>PWRGD</sub> = 60V	●			5	μA
	T <sub>2P</sub> Leakage Current	T <sub>2P</sub> = 60V	●			5	μA

**Hot Swap Control**

I <sub>GPU</sub>	HSGATE Pull-Up Current	V <sub>HSGATE</sub> - V <sub>HSSRC</sub> = 5V (Note 6)	●	-27	-22	-18	μA
V <sub>GOC</sub>	HSGATE Open Circuit Voltage	-10μA Load, with Respect to HSSRC	●	10		18	V
	HSGATE Pull-Down Current	V <sub>HSGATE</sub> - V <sub>HSSRC</sub> = 5V	●	200			μA

**Timing**

	T <sub>2P</sub> Frequency	V <sub>AUX</sub> > V <sub>AUXT</sub> , and RCLASS++ Has Resistor to GND	●	690	840	990	Hz
	T <sub>2P</sub> Duty Cycle in PoE Operation (Note 5)	After LTPoE++ 3-Event Classification After 4-Event Classification After 5-Event Classification (RCLASS++ Has Resistor to GND)			75 50 25		% % %
	T <sub>2P</sub> Duty Cycle in Auxiliary Supply Operation (Note 5)	V <sub>AUX</sub> > V <sub>AUXT</sub> , and RCLASS++ Has Resistor to GND			75		%
	1st Classification Event Timing Threshold		●	31		87	ms

**Note 1:** Stresses beyond those listed under Absolute Maximum Ratings may cause permanent damage to the device. Exposure to any Absolute Maximum Rating condition for extended periods may affect device reliability and lifetime.

**Note 2:** Signature resistance specifications do not include resistance added by the external diode bridge which can add as much as 1.1k to the port resistance.

**Note 3:** All voltages with respect to GND unless otherwise noted. Positive currents are into pins; negative currents are out of pins unless otherwise noted.

**Note 4:** This IC includes overtemperature protection that is intended to protect the device during momentary overload conditions. Junction temperature will exceed 150°C when overtemperature protection is active. Continuous operation above the specified maximum operating junction temperature may impair device reliability.

**Note 5:** Specified as the percentage of the period which T<sub>2P</sub> is low impedance with respect to GND. Appears after PWRGD valid.

**Note 6:** I<sub>GPU</sub> available in PoE powered operation. That is, available after V<sub>VPORT</sub> > V<sub>HSON</sub> and V<sub>AUX</sub> < V<sub>AUXT</sub>, over the range where V<sub>VPORT</sub> is between V<sub>HSOFF</sub> and 60V.

# TYPICAL PERFORMANCE CHARACTERISTICS

**Input Current vs Input Voltage 25k Detection Signature Range**

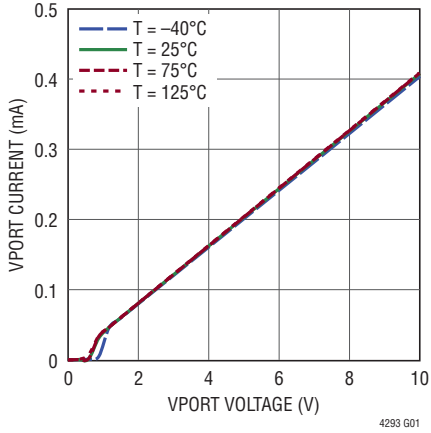

**VPORT Hot Swap Thresholds**

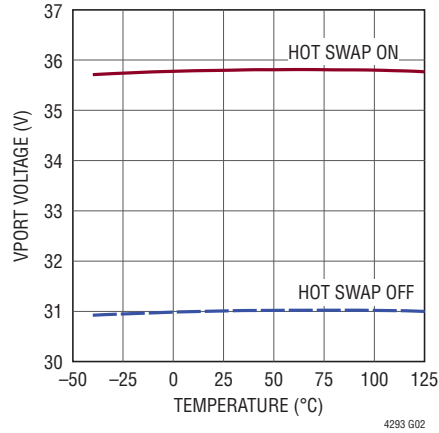

**Supply Current During Power-On**

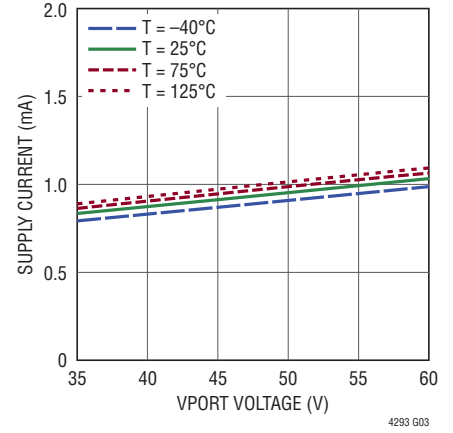

**Detection Signature Resistance vs Input Voltage**

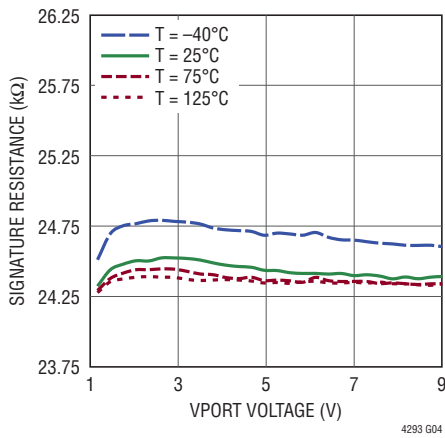

**Reset Threshold**

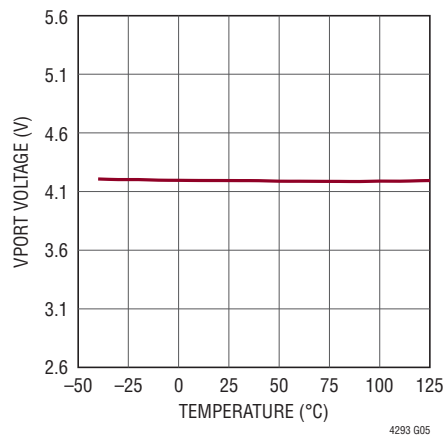

**PWRGD, T2P Output Low Voltage vs Current**

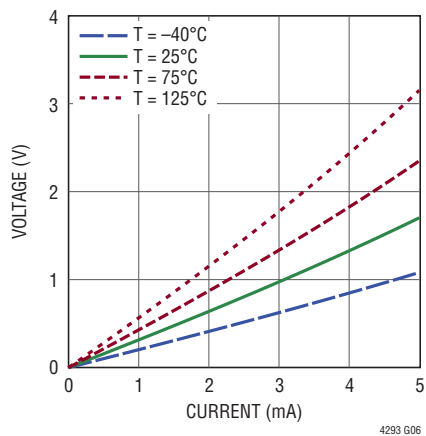

**VPORT Classification Thresholds**

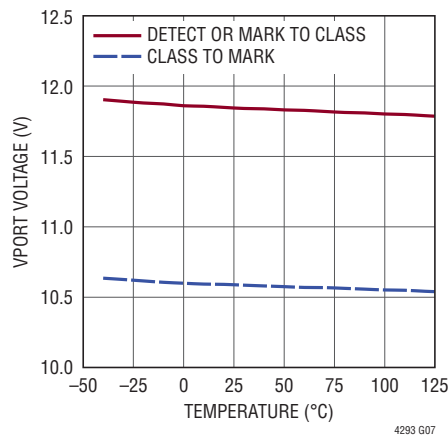

**T2P Frequency**

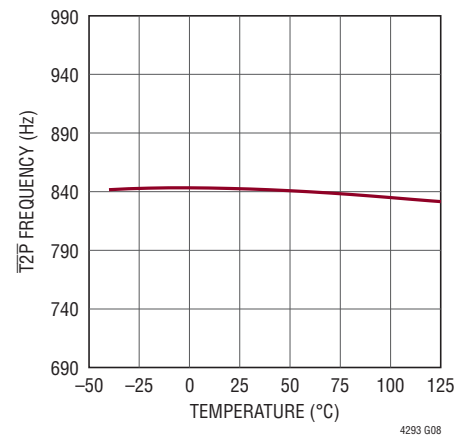

## PIN FUNCTIONS

**GND (Pins 1, 5, DFN Exposed Pad Pin 11):** Device Ground. Exposed pad must be electrically and thermally connected to pin 5 and PCB GND.

**AUX (Pin 2):** Auxiliary Sense. A resistive divider from the auxiliary power input to AUX sets the voltage at which the auxiliary supply takes over. In auxiliary power operation, HSGATE pulls down, the signature resistor disconnects, classification is disabled, the PWRGD pin is high impedance and  $\overline{T2P}$  indicates max available power. The AUX pin sinks  $I_{AUXH}$  when below its threshold voltage of  $V_{AUXT}$  to provide hysteresis. Connect to GND when not used.

**RCLASS (Pin 3):** Configurable PoE Classification Resistor. See Table 2.

**RCLASS++ (Pin 4):** Configurable PoE Classification Resistor. See Table 2.

**$\overline{T2P}$  (Pin 6):** PSE Type Indicator, Open-Drain Output. See the  $\overline{T2P}$  Output section in Applications Information for pin behavior.

**PWRGD (Pin 7):** Power Good Indicator, Open-Drain Output. Pulls to GND during  $V_{CLASS}$  and inrush.

**HSSRC (Pin 8):** External Hot Swap MOSFET Source. Connect to source of the external MOSFET.

**HSGATE (Pin 9):** External Hot Swap MOSFET Gate Control, Output. Connect to gate of the external MOSFET.

**VPORT (Pin 10):** PD interface upper power rail and external Hot Swap MOSFET drain connection.

**BLOCK DIAGRAM**

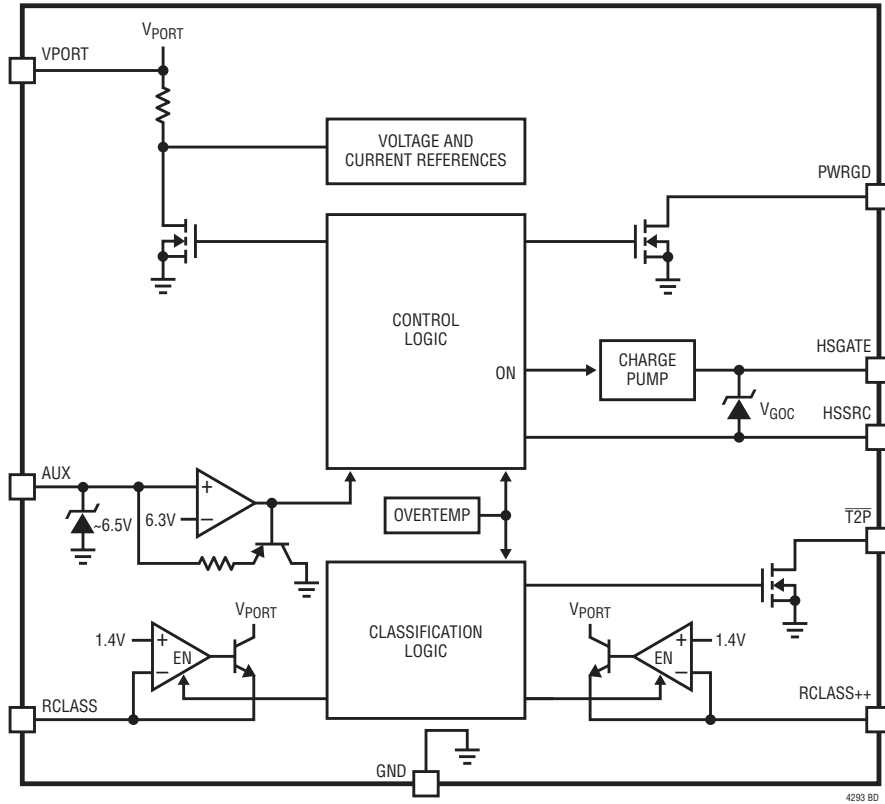

## APPLICATIONS INFORMATION

### OVERVIEW

Power over Ethernet (PoE) continues to gain popularity as products take advantage of DC power and high speed data available from a single RJ45 connector. Powered device (PD) equipment vendors are running into the 25.5W power limit established by the IEEE 802.3at standard.

The LT4293 is an LTPoE++/IEEE 802.3bt-compliant PD interface controller, and allows up to 90W operation while maintaining backwards compatibility with existing PSE systems. The T2P output distinguishes between LTPoE++ and IEEE 802.3bt power sourcing equipment (PSE) during mutual identification and negotiation of available power. The LT4293 controls a low  $R_{DS(ON)}$  N-channel MOSFET to maximize efficiency and delivered power.

Analog Devices also provides a complete family of PSE, PD and ideal bridge solutions. See Related Parts section at the end of this data sheet.

### MODES OF OPERATION

#### Detection Signature

During detection, the PSE looks for a 25k signature resistor which identifies the device as a PD. The PSE will apply two voltages in the range of 2.7V to 10.1V and measure the corresponding currents. Figure 1 shows the detection voltages. The PSE calculates the signature resistance using a  $\Delta V/\Delta I$  measurement technique.

The LT4293 presents its precision, temperature-compensated 24.4k resistor between the VPORT and GND pins, allowing the PSE to recognize a PD is present and requesting power to be applied. The LT4293 signature resistor is smaller than 25k to compensate for the additional series resistance introduced by the IEEE required bridge or the LT4321-based ideal bridge.

#### IEEE 802.3bt Single-Signature vs Dual-Signature PDs

IEEE 802.3bt defines two PD topologies: single-signature and dual-signature. The LT4293 primarily targets single-signature PD topologies, eliminating the need for a second PD controller. All PD descriptions and IEEE 802.3

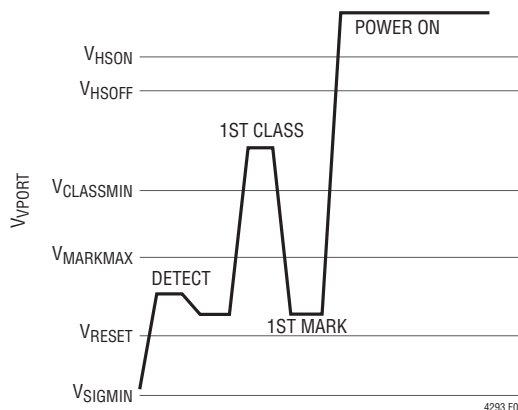

Figure 1. Type 3 or 4 PSE, 1-Event Class Sequence

standard references in this data sheet are limited in scope to single-signature PDs.

The LT4293 may be deployed in dual-signature PD applications. For more information, contact Analog Devices Applications.

#### Classification Signature and Mark

The classification/mark process varies depending on the PSE type. A PSE, after a successful detection, may apply a classification probe voltage of 14.5V to 20.5V and measure the PD classification signature current. Once the PSE applies a classification probe voltage, the PSE returns the PD voltage to the mark voltage range before applying another classification probe voltage, or powering up the PD.

An example of 1-Event classification is shown in Figure 1. In 2-Event classification, a PSE probes for power classification twice as shown in Figure 2. An IEEE 802.3bt PSE may apply as many as 5 events before powering up the PD.

#### IEEE 802.3bt Physical Classification and Demotion

IEEE 802.3bt defines physical classification to allow a PD to request a power allocation from the connected PSE and to allow the PSE to inform the PD of the PSE's available power. Demotion is provided if the PD Requested Power level is not available at the PSE. If demoted, the PD must operate in a lower power state.

APPLICATIONS INFORMATION

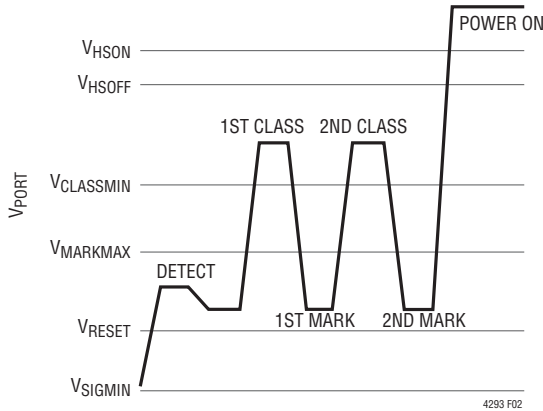

Figure 2. Type 2 PSE, 2-Event Class Sequence

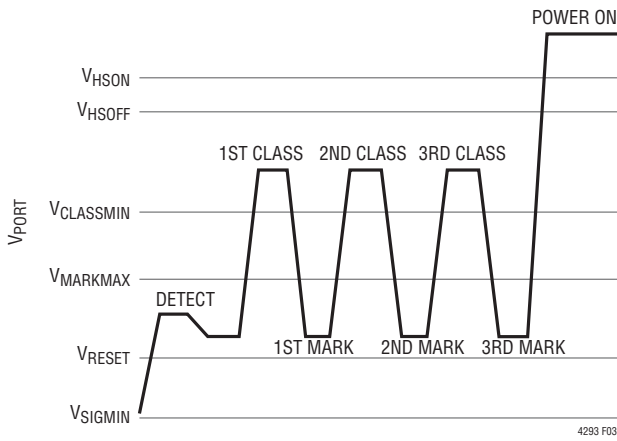

Figure 3. Type 3 or 4 PSE, 3-Event Class Sequence

The number of class/mark events issued by the PSE directly indicates the power allocated to the PD and is summarized in Table 1.

IEEE 802.3bt provides nine PD classes and four PD types, as shown in Table 2. The LT4293 class is configured by setting the  $R_{CLS}$  and  $R_{CLS++}$  resistor values.

IEEE 802.3bt PSEs present a single classification event (see Figure 1) to Class 0 through 3 PDs. A Class 0 through 3 PD presents its class signature to the PSE and is then powered on if sufficient power is available. Power limited IEEE 802.3bt PSEs may issue a single event to Class 4 and higher PDs in order to demote those PDs to Class 3 (13W).

Table 1. IEEE 802.3bt PSE Allocated Power

PD REQUESTED CLASS	NUMBER OF PSE CLASS/MARK EVENTS				
	1	2	3	4	5
0	13W				
1	3.84W				
2	6.49W				
3	13W				
4	<b>13W</b>	25.5W			
5	<b>13W</b>	<b>25.5W</b>	40W		
6	<b>13W</b>	<b>25.5W</b>	51W		
7	<b>13W</b>	<b>25.5W</b>	<b>51W</b>	62W	
8	<b>13W</b>	<b>25.5W</b>	<b>51W</b>	71.3W	

Note: Bold indicates the PD has been demoted.

Table 2. LTPoE++/IEEE802.3bt Single-Signature Classification, Power Levels and Resistor Selection

PD REQUESTED CLASS	PD REQUESTED POWER LTPoE++/IEEE802.3bt		PD TYPE LTPoE++/IEEE802.3bt	NOMINAL CLASS CURRENT	RESISTOR (1%)	
					$R_{CLS}$	$R_{CLS++}$
0	13W		Type 1	2.5mA	1.00k $\Omega$	Open
1	3.84W		Type 1 or 3	10.5mA	140 $\Omega$	Open
2	6.49W		Type 1 or 3	18.5mA	76.8 $\Omega$	Open
3	13W		Type 1 or 3	28mA	49.9 $\Omega$	Open
4	25.5W		Type 2 or 3	40mA	34.8 $\Omega$	Open
LTPoE++ 38.7W or 5	38.7W	40W	LTPoE++ or Type 3	40mA/2.5mA	1.00k $\Omega$	37.4 $\Omega$
LTPoE++ 52.7W or 6	52.7W	51W	LTPoE++ or Type 3	40mA/10.5mA	140 $\Omega$	46.4 $\Omega$
LTPoE++ 70W or 7	70W	62W	LTPoE++ or Type 4	40mA/18.5mA	76.8 $\Omega$	64.9 $\Omega$
LTPoE++ 90W or 8	90W	71.3W	LTPoE++ or Type 4	40mA/28mA	49.9 $\Omega$	118 $\Omega$

## APPLICATIONS INFORMATION

IEEE 802.3bt PSEs present up to three classification events to Class 4 PDs (see Figure 3). Class 4 PDs present a class signature 4 on all events. The third event differentiates a Class 4 PD from a higher Class PD. Power-limited IEEE 802.3bt PSEs may issue three events to Class 5 and higher PDs in order to demote those PDs to Class 4 (25.5W).

IEEE 802.3bt PSEs present four classification events (see Figure 4) to Class 5 and 6 PDs. Class 5 and 6 PDs present a class signature 4 on the first two events, then present a class signature 0 or 1, respectively, on the remaining events. Power limited IEEE 802.3bt PSEs may issue four events to Class 7 and higher PDs in order to demote those PDs to Class 6 (51W).

IEEE 802.3bt PSEs present five classification events (see Figure 5) to Class 7 and 8 PDs. Class 7 and 8 PDs present a class signature 4 on the first two events, then present a class signature 2 or 3, respectively, on the remaining events.

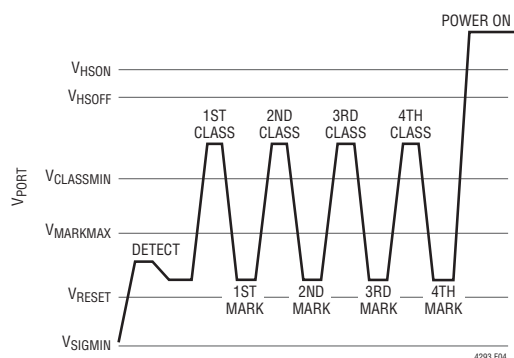

Figure 4. Type 3 or 4 PSE, 4-Event Class Sequence

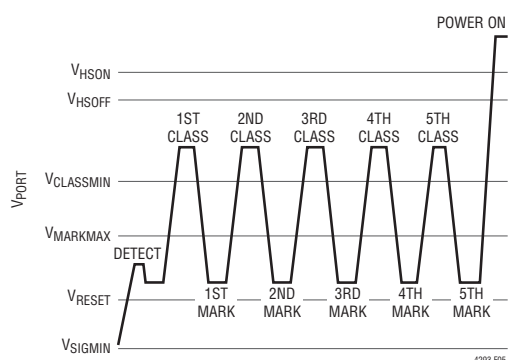

Figure 5. Type 4 PSE, 5-Event Class Sequence

The number of class/mark events is communicated through the LT4293  $\overline{T2P}$  pin. See  $\overline{T2P}$  Output section for more details.

### LTPoE++ Demotion and Denial

Both LTPoE++ and IEEE 802.3 PSEs may demote PDs to a lower power state when the PD Requested Power exceeds the PSE available power. In addition, a power-limited LTPoE++ PSE may deny power to a PD requesting Class 6 or higher. When 2 or fewer class/mark events are received, PD allocated power is at or below 25.5W and LTPoE++ PSEs are considered equivalent to IEEE 802.3 PSEs, as shown in Table 5.

Table 3. LTPoE++ PSE Allocated Power

PD REQUESTED CLASS	NUMBER OF PSE CLASS/MARK EVENTS		
	1	2	3
0	13W		
1	3.84W		
2	6.49W		
3	13W		
4	<b>13W</b>	25.5W	
5	<b>13W</b>	<b>25.5W</b>	38.7W
6	<b>13W</b>	<b>25.5W</b>	52.7W
7	<b>13W</b>	<b>25.5W</b>	70W
8	<b>13W</b>	<b>25.5W</b>	90W

Note: Bold indicates the PD has been demoted.

### Classification Resistors ( $R_{CLS}$ and $R_{CLS++}$ )

The  $R_{CLS}$  and  $R_{CLS++}$  resistors set the classification currents corresponding to the PD power classification. Select the value of  $R_{CLS}$  and  $R_{CLS++}$  from Table 2 and connect each 1% resistor between the RCLASS, RCLASS++ pins and GND.

### Detection Signature Corrupt During Mark Event

During the mark event, the LT4293 presents  $<11k\Omega$  to the port as required by the LTPoE++/IEEE 802.3 specifications.

### Inrush and Power On

Once the PSE detects and classifies the PD, the PSE then powers on the PD. When the port voltage rises above the  $V_{HSON}$  threshold, it begins to source  $I_{GPU}$  out of the

## APPLICATIONS INFORMATION

HSGATE pin. This current flows into an external capacitor,  $C_{GATE}$  in Figure 6, that causes a voltage to ramp up the gate of the external MOSFET. The external MOSFET acts as a source follower and ramps the voltage up on the output bulk capacitor,  $C_{PORT}$ , thereby determining the inrush current,  $I_{INRUSH}$ . Design  $I_{INRUSH}$  to be approximately ~100mA. See equation below:

$$I_{INRUSH} = I_{GPU} \cdot \frac{C_{PORT}}{C_{GATE}}$$

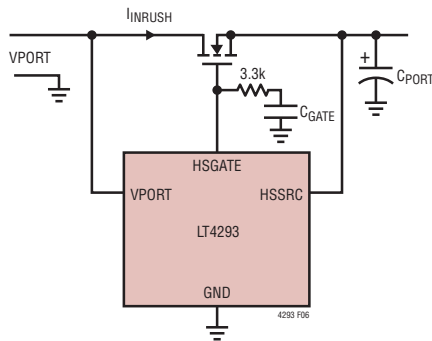

Figure 6. Configuring  $I_{INRUSH}$

The LT4293 internal charge pump provides an N-channel MOSFET solution, eliminating a larger and more costly P-channel MOSFET. The low  $R_{DS(ON)}$  MOSFET also maximizes power delivery and efficiency, reduces power and heat dissipation, and eases thermal design.

### Power Good

The PWRGD pin is held low by its open drain output until HSGATE charges up to approximately 7V above HSSRC. The PWRGD pin is used to hold off the downstream circuitry until inrush is complete and the external MOSFET is fully enhanced. The HSGATE pin remains high and the PWRGD pin remains open-drain until the port voltage falls below  $V_{HSOFF}$ .

### Delay Start

When the PSE powers up the port, the PD application should not draw more than 350mA for 80ms to comply with the IEEE 802.3 standard.

### Auxiliary Supply Override

If the AUX pin is held above  $V_{AUXT}$ , the LT4293 enters auxiliary power supply override mode. In this mode the signature resistor disconnects, classification is disabled, HSGATE pulls down, the PWRGD pin is open drain and  $\overline{T2P}$  pin indicates max available power.

The AUX pin allows for setting the auxiliary supply turn on and turn off voltage thresholds,  $V_{AUXON}$ , and  $V_{AUXOFF}$  respectively. The auxiliary supply hysteresis voltage,  $V_{AUXHYS}$ , is generated with sinking current,  $I_{AUXH}$ , and is active only when the AUX pin voltage is less than  $V_{AUXT}$ . Use the following equations to set  $V_{AUXON}$  and  $V_{AUXOFF}$  via R1 and R2 in Figure 7. Note that an internal 6.5V Zener limits the voltage on the AUX pin.

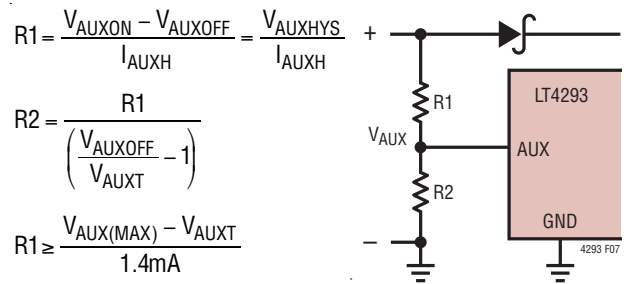

Figure 7. AUX Threshold and Hysteresis Calculation

A capacitor up to 1000pF may be placed between the AUX pin and GND to improve noise immunity.  $V_{AUXON}$  must be lower than  $V_{HSOFF}$ .

### $\overline{T2P}$ Output

The LT4293 communicates the PSE allocated power to the PD application via the  $\overline{T2P}$  pin. The  $\overline{T2P}$  pin state is determined by the AUX pin, the RCLASS++ pin, and the number of classification events. The LT4293 uses a 5-state encoding for the  $\overline{T2P}$  output.  $\overline{T2P}$  state and the associated PSE allocated power are shown in Table 4 and Table 5.

Table 4.  $\overline{T2P}$  Response During Auxiliary Power Operation

PD REQUESTED CLASS	$\overline{T2P}$ *
0 – 4	Low-Z
5 – 8	75%

\*Specified as the percentage of the period which  $\overline{T2P}$  is low impedance with respect to GND.

# APPLICATIONS INFORMATION

**Table 5.  $\overline{T2P}$  Response During PoE Operation**

POWER SOURCE	NUMBER OF CLASS/MARK EVENTS	$\overline{T2P}^*$	PSE ALLOCATED POWER
LTPoE++	1	Hi-Z	Min (PD Requested Power, 13W)
	2	Low-Z	25.5W
	3	75%	LTPoE++ PD Requested Power
IEEE 802.3	1	Hi-Z	Min (PD Requested Power, 13W)
	2 or 3	Low-Z	25.5W
	4	50%	Min (PD Requested Power, 51W)
	5	25%	Min (PD Requested Power, 71.3W)

\*Specified as the percentage of the period which  $\overline{T2P}$  is low impedance with respect to GND.

The highest priority input is the AUX pin. AUX is asserted to enter the auxiliary power state and deasserted to enter the PoE state. In the auxiliary power state, the  $\overline{T2P}$  pin indicates the highest available power, based on PD Requested Class. The auxiliary power supply must be sized to provide at least the PD Requested Class Power.

Second, PD Requested Class and PD Requested Power are configured using the RCLASS and RCLASS++ pins.

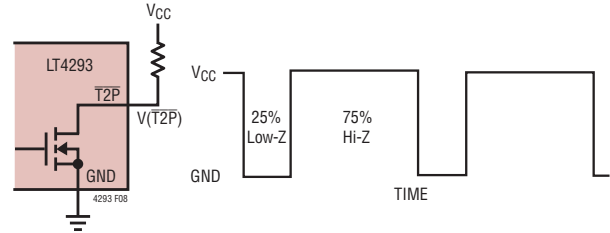

**Figure 8. Response Example for 25% Low-Z, 75% Hi-Z**

The RCLASS++ pin alone can be used to determine if the PD Class is 0–4, 5–8 or LTPoE++ as shown in Table 2.

Last, the PSE type and the number of classification events determine the amount of power allocated by the PSE as described in Table 1 and Table 3.

## Interoperability Across Various PSEs and Auxiliary Power Source

Table 6 summarizes the expected LT4293  $\overline{T2P}$  response, the PSE allocated power and the number of classification events. The result is a function of PD Requested Class and power source—Auxiliary or PoE.

**Table 6. LT4293 Interoperability ( $\overline{T2P}$  Response\*, Allocated Power, Number of Class/Mark Events)**

REQUESTED PD CLASS (REQUESTED POWER)	PSE TYPE, CLASS (POWER)											AUXILIARY POWER SOURCE**	
	IEEE 802.3 TYPE 1	IEEE 802.3 TYPE 2	IEEE 802.3 TYPE 3			IEEE 802.3 TYPE 4		LTPoE++					
	CLASS 3 (13W)	CLASS 4 (25.5W)	CLASS 4 (25.5W)	CLASS 5 (40W)	CLASS 6 (51W)	CLASS 7 (62W)	CLASS 8 (71.3W)	(38.7W)	(52.7W)	(70W)	(90W)		
<b>CLASS 0–3 (Up to 13W)</b>	Hi-Z Up to 13W 1-Event	Hi-Z Up to 13W 1-Event	Hi-Z Up to 13W 1-Event	Hi-Z Up to 13W 1-Event	Hi-Z Up to 13W 1-Event	Hi-Z Up to 13W 1-Event	Hi-Z Up to 13W 1-Event	Hi-Z Up to 13W 1-Event	Hi-Z Up to 13W 1-Event	Hi-Z Up to 13W 1-Event	Hi-Z Up to 13W 1-Event	Hi-Z Up to 13W 1-Event	Low-Z Aux. Power N/A
<b>CLASS 4 (25.5W)</b>	Hi-Z 13W 1-Event	Low-Z 25.5W 2-Event	Low-Z 25.5W 3-Event	Low-Z 25.5W 3-Event	Low-Z 25.5W 3-Event	Low-Z 25.5W 3-Event	Low-Z 25.5W 3-Event	Low-Z 25.5W 2-Event	Low-Z 25.5W 2-Event	Low-Z 25.5W 2-Event	Low-Z 25.5W 2-Event	Low-Z 25.5W 2-Event	Low-Z Aux. Power N/A
<b>CLASS 5 (40W)</b>	Hi-Z 13W 1-Event	Low-Z 25.5W 2-Event	Low-Z 25.5W 3-Event	50% 40W 4-Event	50% 40W 4-Event	50% 40W 4-Event	50% 40W 4-Event	75% 38.7W 3-Event	75% 38.7W 3-Event	75% 38.7W 3-Event	75% 38.7W 3-Event	75% 38.7W 3-Event	75% Aux. Power N/A
<b>CLASS 6 (51W)</b>	Hi-Z 13W 1-Event	Low-Z 25.5W 2-Event	Low-Z 25.5W 3-Event	Low-Z 25.5W 3-Event	50% 51W 4-Event	50% 51W 4-Event	50% 51W 4-Event	DENIED 52.7W 3-Event	75% 52.7W 3-Event	75% 52.7W 3-Event	75% 52.7W 3-Event	75% 52.7W 3-Event	75% Aux. Power N/A
<b>CLASS 7 (62W)</b>	Hi-Z 13W 1-Event	Low-Z 25.5W 2-Event	Low-Z 25.5W 3-Event	Low-Z 25.5W 3-Event	50% 51W 4-Event	25% 62W 5-Event	25% 62W 5-Event	DENIED DENIED	DENIED DENIED	75% 70W 3-Event	75% 70W 3-Event	75% 70W 3-Event	75% Aux. Power N/A
<b>CLASS 8 (71.3W)</b>	Hi-Z 13W 1-Event	Low-Z 25.5W 2-Event	Low-Z 25.5W 3-Event	Low-Z 25.5W 3-Event	50% 51W 4-Event	50% 51W 4-Event	25% 71.3W 5-Event	DENIED DENIED	DENIED DENIED	DENIED DENIED	75% 90W 3-Event	75% 90W 3-Event	75% Aux. Power N/A

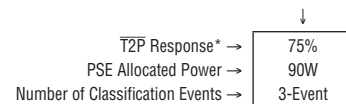

Note 1. Shade of blue indicates the PD has been demoted or denied power.

\* Specified as the percentage of the period which  $\overline{T2P}$  is low impedance with respect to GND.

\*\* Auxiliary Power Supply must be sized to provide PD Requested Power.

## APPLICATIONS INFORMATION

### Overtemperature Protection

The IEEE 802.3 specification requires a PD to withstand any applied voltage from 0V to 57V indefinitely. During classification, however, the power dissipation in the LT4293 may be as high as 1.5W. The LT4293 can easily tolerate this power for the maximum IEEE classification timing but overheats if this condition persists abnormally.

The LT4293 includes an overtemperature protection feature which is intended to protect the device during momentary overload conditions. If the junction temperature exceeds the overtemperature threshold, the LT4293 pulls down HSGATE pin, and disables classification.

### EXTERNAL INTERFACE AND COMPONENT SELECTION

#### PoE Input Bridge

A PD is required to polarity-correct its input voltage. There are several different options available for bridge rectifiers; silicon diodes, Schottky diodes, and ideal diodes. When silicon or Schottky diode bridges are used, the diode forward voltage drops affect the voltage at the VPORT pin. The LT4293 is designed to tolerate these voltage drops. Note, the voltage parameters shown in the Electrical Characteristics are specified at the LT4293 package pins.

A silicon diode bridge consumes up to 4% of the available power. In addition, silicon diode bridges exhibit poor pairset-to-pairset unbalance performance. Each branch of a silicon diode bridge shares source/return current, and thermal runaway can cause large, non-compliant current unbalances between pairsets.

While using Schottky diodes can help reduce the power loss with a lower forward voltage, the Schottky bridge may not be suitable for high temperature PD applications. Schottky diode bridges exhibit temperature induced leakage currents. The leakage current has a voltage dependency that can invalidate the measured detection signature. In addition, these leakage currents can back-feed through the unpowered branch and the unused bridge, violating IEEE 802.3 specifications.

For high efficiency applications, the LT4293 supports an LT4321-based PoE ideal diode bridge that reduces the forward voltage drop from 0.7V to 20mV per diode while maintaining IEEE 802.3 compliance. The LT4321 simplifies thermal design, eliminates costly heatsinks, and can operate in space-constrained applications.

#### Auxiliary Input Bridge

Some PDs are required to receive AC or DC power from an auxiliary power source. A diode bridge is typically required to handle the voltage rectification and polarity correction.

In high efficiency applications, or in low auxiliary input voltage applications, the voltage drop across the rectifier cannot be tolerated. The LT4293 can be configured with an LT4320-based ideal diode bridge to recover the diode voltage drop and ease thermal design.

For applications with auxiliary input voltages below 10V, the LT4293 must be configured with an LT4320-based ideal diode bridge to recover the voltage drop and guarantee the minimum VPORT voltage is within the VPORT AUX Mode Range as specified in the Electrical Characteristics table.

#### Input Capacitor

A 0.1 $\mu$ F capacitor is needed from V<sub>PORT</sub> to GND to meet the input impedance requirement in IEEE 802.3 and to properly bypass the LT4293. When operating with the LT4321, locally bypass each with a 0.047 $\mu$ F capacitor, thus keeping the total port capacitance within specification.

#### Transient Voltage Suppressor

The LT4293 specifies an absolute maximum voltage of 100V and is designed to tolerate brief overvoltage events due to Ethernet cable surges. To protect the LT4293 from an overvoltage event, install a unidirectional transient voltage suppressor (TVS) such as an SMAJ58A between the V<sub>PORT</sub> and GND pins. For PD applications that require

## APPLICATIONS INFORMATION

an auxiliary power input, install a TVS between  $V_{IN}$  and GND. See Layout Considerations for TVS placement.

For extremely high cable discharge and surge protection, contact Analog Devices Applications.

### Exposed Pad

The LT4293 DFN package has an exposed pad that is internally connected to GND. The exposed pad may only be connected to GND on the printed circuit board.

## LAYOUT CONSIDERATIONS

Avoid excessive parasitic capacitance on the RCLASS and RCLASS++ pins and place resistors  $R_{CLS}$  and  $R_{CLS++}$  close to the LT4293.

It is strictly required for maximum protection to place the 0.1 $\mu$ F input capacitor,  $C_{PD}$ , and transient voltage suppressor as close to the LT4293 as possible. When operating the LT4293 with the LT4321, place a 0.047 $\mu$ F capacitor,  $C_{PD1}$ , as close as possible to the LT4293 VPORT and GND pins (pin 10 and pin 5, respectively), and a 0.047 $\mu$ F capacitor,  $C_{PD2}$ , as close as possible to the LT4321 OUTP and OUTN pins.

## TYPICAL APPLICATIONS

LTPoE++/IEEE 802.3bt-Compliant > 99% Efficient 51W Powered Device

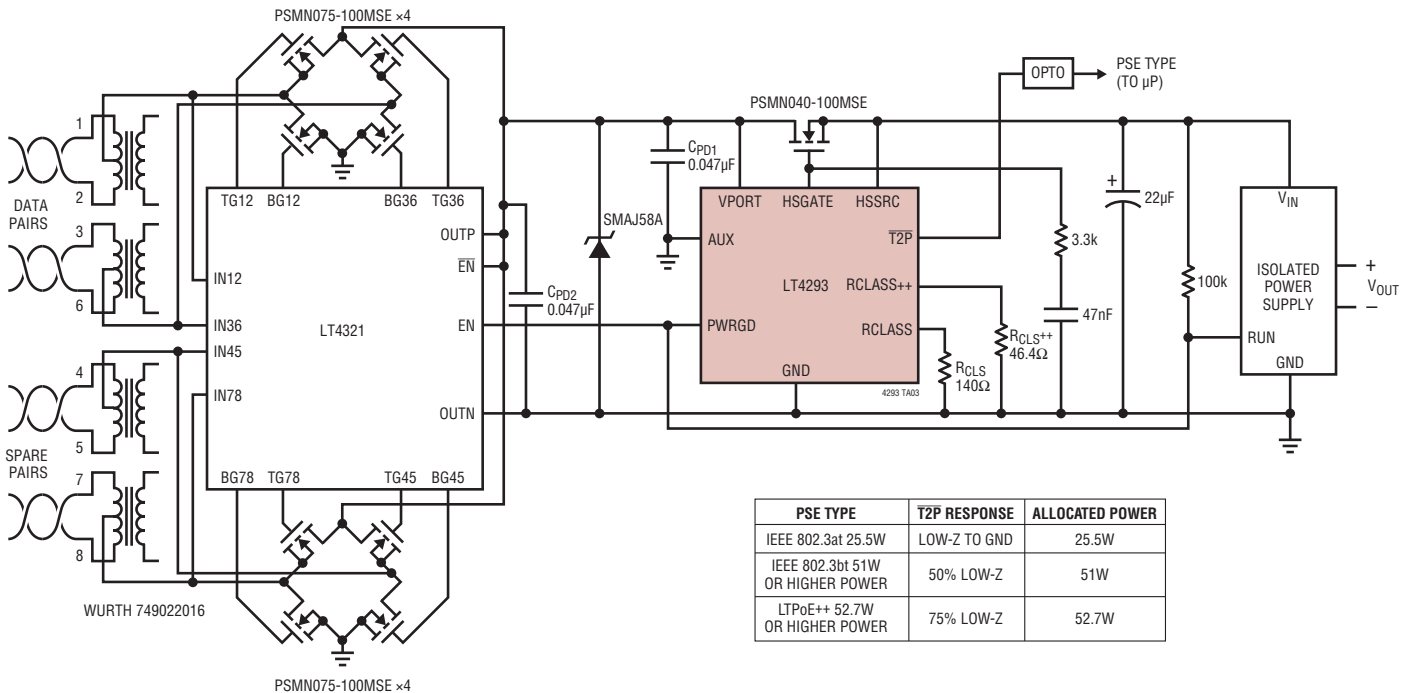

**PACKAGE DESCRIPTION**

**DD Package**  
**10-Lead Plastic DFN (3mm × 3mm)**  
 (Reference LTC DWG # 05-08-1699 Rev C)

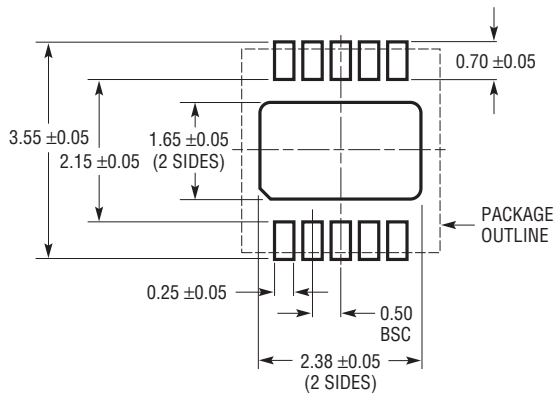

**RECOMMENDED SOLDER PAD PITCH AND DIMENSIONS**

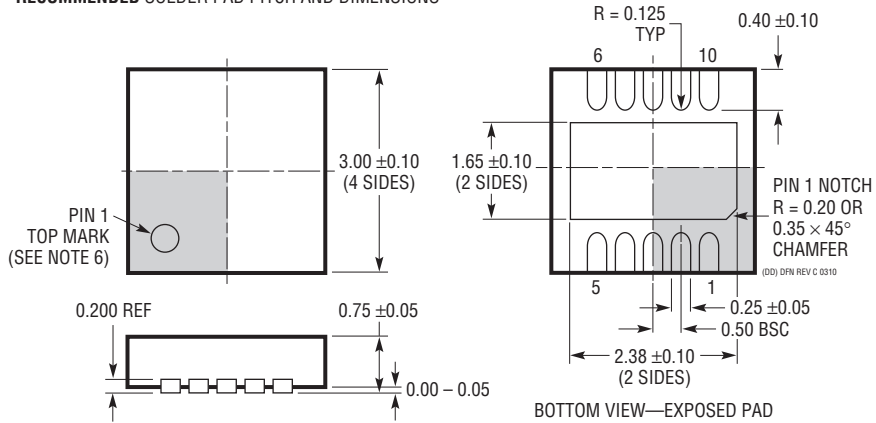

**NOTE:**

1. DRAWING TO BE MADE A JEDEC PACKAGE OUTLINE M0-229 VARIATION OF (WEED-2). CHECK THE LTC WEBSITE DATA SHEET FOR CURRENT STATUS OF VARIATION ASSIGNMENT
2. DRAWING NOT TO SCALE
3. ALL DIMENSIONS ARE IN MILLIMETERS
4. DIMENSIONS OF EXPOSED PAD ON BOTTOM OF PACKAGE DO NOT INCLUDE MOLD FLASH. MOLD FLASH, IF PRESENT, SHALL NOT EXCEED 0.15mm ON ANY SIDE
5. EXPOSED PAD SHALL BE SOLDER PLATED
6. SHADED AREA IS ONLY A REFERENCE FOR PIN 1 LOCATION ON THE TOP AND BOTTOM OF PACKAGE

**PACKAGE DESCRIPTION**

**MS Package**  
**10-Lead Plastic MSOP**  
 (Reference LTC DWG # 05-08-1661 Rev F)

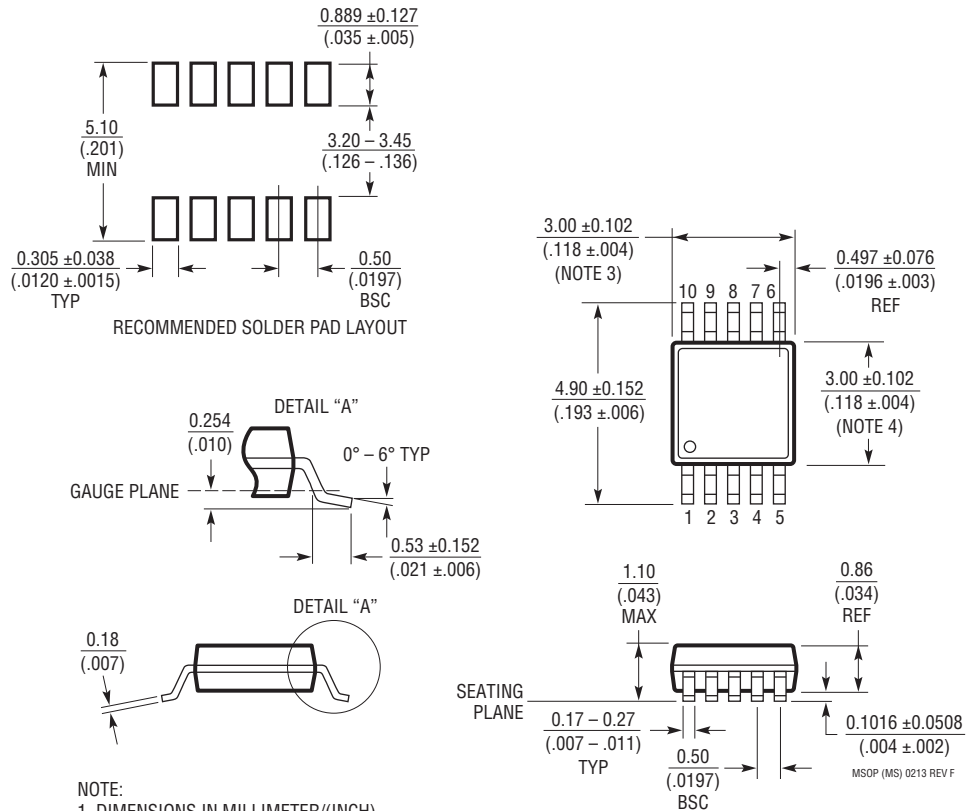

- NOTE:
1. DIMENSIONS IN MILLIMETER/(INCH)
  2. DRAWING NOT TO SCALE
  3. DIMENSION DOES NOT INCLUDE MOLD FLASH, PROTRUSIONS OR GATE BURRS.  
MOLD FLASH, PROTRUSIONS OR GATE BURRS SHALL NOT EXCEED 0.152mm (.006") PER SIDE
  4. DIMENSION DOES NOT INCLUDE INTERLEAD FLASH OR PROTRUSIONS.  
INTERLEAD FLASH OR PROTRUSIONS SHALL NOT EXCEED 0.152mm (.006") PER SIDE
  5. LEAD COPLANARITY (BOTTOM OF LEADS AFTER FORMING) SHALL BE 0.102mm (.004") MAX

## TYPICAL APPLICATION

LTPoE++/IEEE 802.3bt > 99% Efficient 71.3W Powered Device

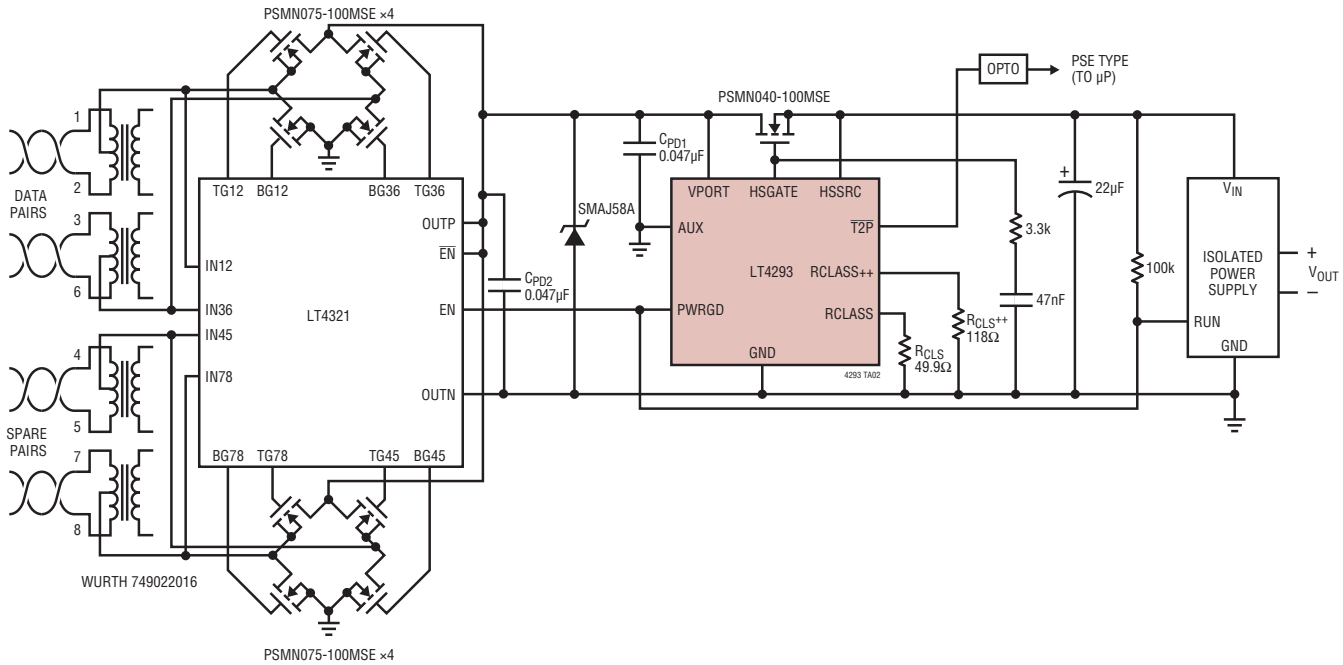

## RELATED PARTS

PART NUMBER	DESCRIPTION	COMMENTS
<a href="#">LT4295</a>	IEEE 802.3bt PD with Forward/Flyback Switching Regulator Controller	External Switch, IEEE 802.3bt Support, Configurable Class, Forward or No-Opto Flyback Operation, Frequency, PG/SG Delays, Soft-Start, and Aux Support as Low as 9V, Including Housekeeping Buck, Slope Compensation
<a href="#">LT4294</a>	IEEE 802.3bt PD Controller	External Switch, IEEE 802.3bt and Aux Support
<a href="#">LT4321</a>	PoE Ideal Diode Bridge Controller	Controls 8-NMOSFETs for IEEE-Required PD Voltage Rectification without Diode Drops
<a href="#">LT4320/LT4320-1</a>	Ideal Diode Bridge Controller	9V to 72V, DC to 600Hz Input. Controls 4-NMOSFETs, Voltage Rectification without Diode Drops
<a href="#">LTC4292/LTC4291-1</a>	4-Port IEEE 802.3bt PSE Controller	Transformer Isolation, Supports IEEE 802.3bt PDs
<a href="#">LTC4279</a>	Single PoE/PoE+/LTPoE++ PSE Controller	Supports IEEE 802.3af, IEEE 802.3at, LTPoE++ and Proprietary PDs
<a href="#">LT4276A/B/C</a>	LTPoE++/PoE+/PoE PD with Forward/Flyback Switching Regulator Controller	External Switch, LTPoE++ Support, User-Configurable Class, Forward or No-Opto Flyback Operation, Frequency, PG/SG Delays, Soft-Start, and Aux Support as Low as 9V, Including Housekeeping Buck, Slope Compensation
<a href="#">LT4275A/B/C</a>	LTPoE++/PoE+/PoE PD Controller	External Switch, LTPoE++ Support
<a href="#">LTC4269-1</a>	IEEE 802.3at PD Interface with Integrated Flyback Switching Regulator	2-Event Classification, Programmable Class, Synchronous No-Opto Flyback Controller, 50kHz to 250kHz, Aux Support
<a href="#">LTC4269-2</a>	IEEE 802.3at PD Interface with Integrated Forward Switching Regulator	2-Event Classification, Programmable Class, Synchronous Forward Controller, 100kHz to 500kHz, Aux Support
<a href="#">LTC4278</a>	IEEE 802.3at PD Interface with Integrated Flyback Switching Regulator	2-Event Classification, Programmable Class, Synchronous No-Opto Flyback Controller, 50kHz to 250kHz, 12V Aux Support
<a href="#">LTC4267/LTC4267-1/LTC4267-3</a>	IEEE 802.3af PD Interface with Integrated Switching Regulator	Internal 100V, 400mA Switch, Programmable Class, 200kHz/300kHz Constant Frequency PWM
<a href="#">LTC4290/LTC4271</a>	8-Port PoE/PoE+/LTPoE++ PSE Controller	Transformer Isolation, Supports IEEE 802.3af, IEEE 802.3at and LTPoE++ PDs

## Looking for pricing, stock, or lifecycle information?

Click below to explore more details on WIN SOURCE:

 [View LT4293HDD#PBF on WIN SOURCE](#)

 [Analog Devices Inc. Information](#)

## Optimize Your Supply Chain with WIN SOURCE Solutions

-  Global Sourcing Solution
-  Obsolete Management
-  Cost Control Management
-  Shortage Management
-  Alternative Solution
-  Excess Inventory Management