



# THE DATASHEET OF UM3243EEASR



---

***Low Supply Current, 3V to 5.5V, 250kbps, 3-Driver/5-Receiver,  
Enhanced ESD Protection Smart RS-232 Transceivers  
UM3243EEAS/UM3243EEASR/  
UM3243EEUS/UM3243EESS/UM3243EEQA***

### **General Description**

The UM3243 series are 3-driver/5-receiver 3V-5.5V powered RS-232 transceivers featuring Auto Power-Off and low supply current, when no valid RS-232 level signal is sensed on any receiver inputs, the charge pump circuit and drivers will be powered off. Disconnection of the RS-232 cable or poweroff of the transmitters of the attaching peripherals will lead to Power-Off mode. When a valid level is applied to any RS-232 receiver inputs, the chip will turn on again. The Auto Power-Off mode helps to save power without changing the existing system.

The UM3243 transceivers have a regulated discontinuous mode dual charge pump power supply and low-dropout transmitters, which combine to deliver true RS-232 performance from a single +3V to +5.5V supply. Data rate of 250kbps is guaranteed.

The UM3243 needs only four 0.1 $\mu$ F capacitors in 3.3V operation, and can operate from input voltages ranging from +2.7V to +5.5V. They are ideal for 3.3V-only systems, mixed 3.3V and 5.0V systems, or 5.0V-only systems that require true RS-232 performance or EIA/TIA-562 levels of  $\pm 3.7$ V with supply voltages as low as 2.7V.

The UM3243 includes one complementary always-active receiver. This receiver can monitor an external device (such as a modem) in Power-Off. The UM3243 also includes an always-active INVALID output which indicates valid RS-232 signal levels on any receiver inputs. It is usually used in UART wakeup. The UM3243 also features enhanced ESD protection with  $\pm 15$ kV for human body mode and  $\pm 8$ kV for IEC61000-4-2 contact discharge mode.

### **Applications**

- Industrial Controllers and Instruments
- Notebooks, Palmtop PCs and Laptops
- Networking Routers and Switches
- Peripherals
- Printers, PDAs and POS

### **Features**

- Meets True EIA/TIA-232-F Standards from a +3.0V to +5.5V Power Supply
- Meets EIA/TIA-562 Levels of  $\pm 3.7$ V with Supply Voltages as Low as 2.7V
- Auto Power-Off Feature to Disable Driver Outputs when No Valid RS-232 Signal is Sensed
- 250kbps Minimum Transmission Rate
- 0.1 $\mu$ A (Typ) Low Power-Off Current
- Accepts 5V Logic Input with 3.3V Supply
- Latch-Up Performance Exceeds 200mA
- Enhanced ESD Specifications for RS-232 Pins:
  - ±15kV Human Body Mode
  - ±8kV IEC61000-4-2 Contact Discharge Mode
- Available in SSOP28, TSSOP28, SOP28 and QFN32 Packages

## Pin Configurations

## Top View

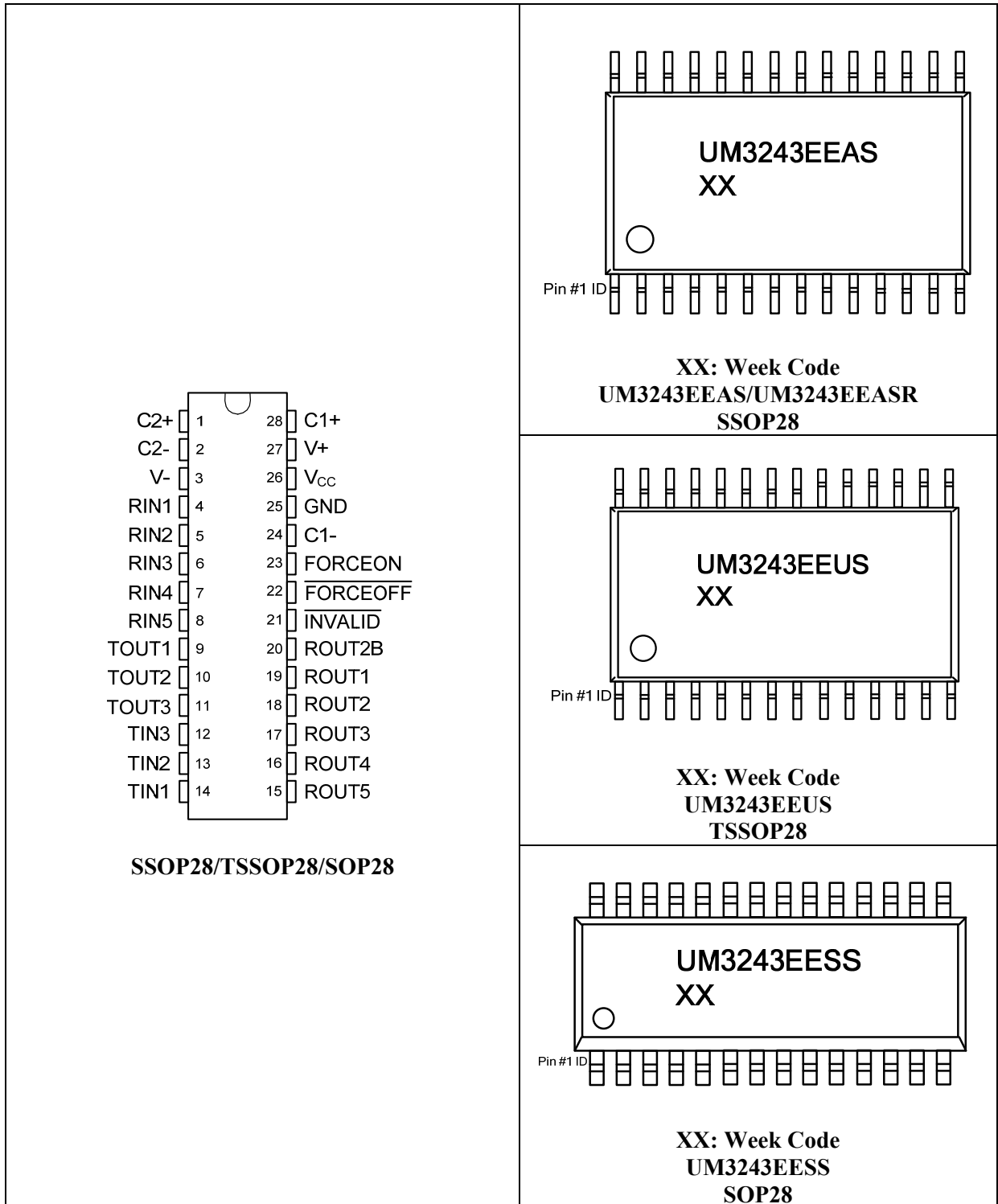

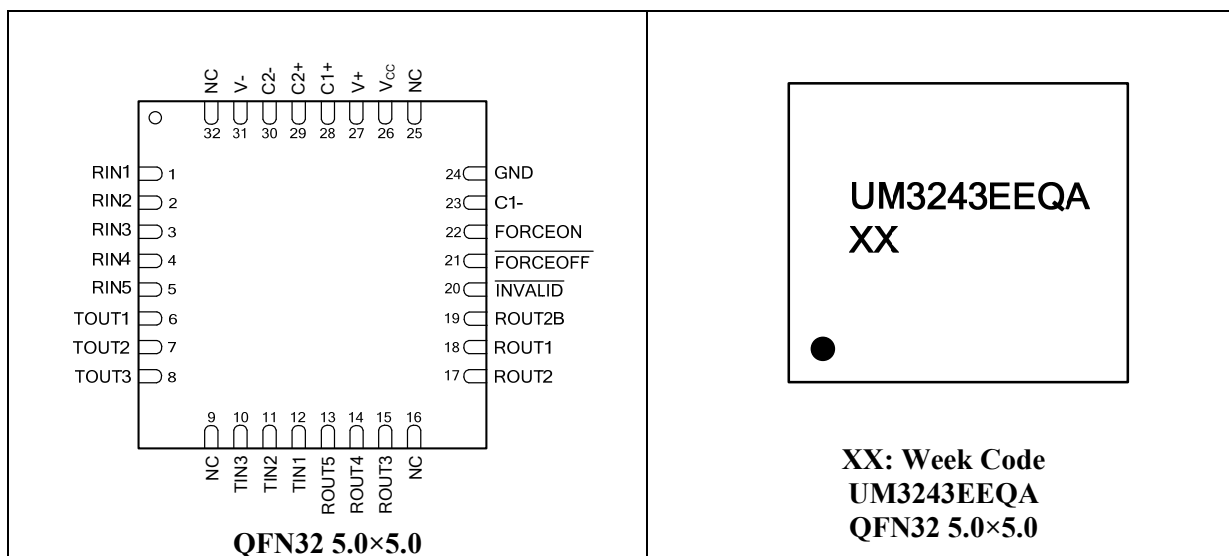

## Pin Description

Pin No.		Pin Name	Function
UM3243EEAS/EEASR/EEUS/EESS	UM3243EEQA		
1	29	C2+	Positive Terminal of Inverting Charge-Pump Capacitor
2	30	C2-	Negative Terminal of Inverting Charge-Pump Capacitor
3	31	V-	Negative Voltage Generated by the Charge Pump
4-8	1-5	RIN <sub>n</sub>	RS-232 Receiver Inputs
9, 10, 11	6, 7, 8	TOUT <sub>n</sub>	RS-232 Transmitter Outputs
12, 13, 14	10, 11, 12	TIN <sub>n</sub>	TTL/CMOS Transmitter Inputs
15-19	13, 14, 15, 17, 18	ROUT <sub>n</sub>	TTL/CMOS Receiver Outputs
20	19	ROUT2B	Non-Inverting Receiver Output—active in Power-Off
21	20	INVALID	Output of the Valid Signal Detector. INVALID is enabled high if a valid RS-232 level is present on any receiver inputs.
22	21	FORCEOFF	Drive low to shut down transmitters and on-board power supply. This overrides all Automatic circuitry and FORCEON (See Function Tables).
23	22	FORCEON	Drive high to override automatic circuitry keeping transmitters on (FORCEOFF must be high) (See Function Tables).
24	23	C1-	Negative Terminal of the Voltage Doubler Charge-Pump Capacitor
25	24	GND	Ground
26	26	V <sub>CC</sub>	+3.0V to +5.5V Supply Voltage
27	27	V+	Positive Voltage Generated by the Charge Pump
28	28	C1+	Positive Terminal of the Voltage Doubler Charge-Pump Capacitor
-	9, 16, 25, 32	NC	Not connected.

## Ordering Information

Part Number	Temp. Range	Package Type	Shipping Qty
UM3243EEAS	-40°C to +85°C	SSOP28	48pcs/Tube
UM3243EEASR	-40°C to +85°C	SSOP28	2000pcs/13Inch Tape & Reel
UM3243EEUS	-40°C to +85°C	TSSOP28	3000pcs/13Inch Tape & Reel
UM3243EESS	-40°C to +85°C	SOP28	25pcs/Tube
UM3243EEQA	-40°C to +85°C	QFN32 5.0×5.0	3000pcs/13Inch Tape & Reel

## Absolute Maximum Ratings (Note 1)

Symbol	Parameter	Value	Unit	
V <sub>CC</sub>	Supply Voltage on V <sub>CC</sub>	-0.3 to +6	V	
V <sub>+</sub>	Voltage on V <sub>+</sub>	(V <sub>CC</sub> -0.3) to +7.5	V	
V <sub>-</sub>	Voltage on V <sub>-</sub>	-7.5 to +0.3	V	
	Voltage on TIN <sub>-</sub> , FORCEOFF, FORCEON	-0.3 to +6V	V	
	Voltage on ROUT <sub>-</sub> , INVALID, ROUT2B	-0.3 to (V <sub>CC</sub> +0.3)	V	
	Voltage on RIN <sub>-</sub>	±30	V	
	Voltage on TOUT <sub>-</sub>	(V <sub>-</sub> -0.3) to (V <sub>+</sub> +0.3)	V	
	Short-Circuit Duration, TOUT <sub>-</sub> to GND	Continuous		
P <sub>D</sub>	Continuous Power Dissipation at T <sub>A</sub> =70°C	SSOP28	762	mW
		TSSOP28	696	
		SOP28	1000	
		QFN32	1500	
T <sub>A</sub>	Operating Temperature Range	-40 to +85	°C	
T <sub>STG</sub>	Storage Temperature Range	-65 to +165	°C	
T <sub>L</sub>	Maximum Lead Temperature for Soldering 10 Seconds	+300	°C	

Note 1: Stresses beyond those listed under “Absolute Maximum Ratings” may cause permanent damage to the device. These are stress ratings only, and functional operation of the device at these or any other conditions beyond those indicated in the operational sections of the specifications is not implied. Exposure to absolute maximum rating conditions for extended periods may affect device reliability.

**Electrical Characteristics**

( $V_{CC}=+3.0V$  to  $+5.5V$ ,  $C1-C4=0.1\mu F$ ,  $T_A=T_{MIN}$  to  $T_{MAX}$ , unless otherwise noted. Typical values are at  $T_A=25^\circ C$ )

Parameter	Symbol	Conditions	Min	Typ	Max	Unit	
<b>DC CHARACTERISTICS</b> ( $V_{CC}=+3.3V$ or $+5V$ , $T_A=25^\circ C$ )							
Supply Voltage		$V_{CC}=3.3V$	3.0	3.3	3.6	V	
		$V_{CC}=5.0V$	4.5	5.0	5.5		
Supply Current, Auto Power-Off	$I_{CC}$	All $RIN\_Open$ , $FORCEON=GND$ , $FORCEOFF=V_{CC}$		0.1	10	$\mu A$	
Supply Current, Forced Power-Off		$FORCEOFF=GND$		0.1	10	$\mu A$	
Supply Current, Normal		$FORCEON=FORCEOFF=V_{CC}$ , Other Input NC, All Outputs with No Load		0.6	1.0	mA	
<b>LOGIC INPUTS</b>							
Input Logic Threshold Low		$TIN\_$ , $FORCEON$ , $\overline{FORCEOFF}$			0.8	V	
Input Logic Threshold High		$TIN\_$ , $FORCEON$ , $FORCEOFF$	$V_{CC}=3.3V$	2.0		V	
			$V_{CC}=5.0V$	2.4			
Input Hysteresis	$V_{hys}$			0.2		V	
Input Leakage Current	$I_{IL}$	$FORCEON$ , $\overline{FORCEOFF}$		$\pm 0.01$	$\pm 1.0$	$\mu A$	
		$TIN\_$	Transmitter Disabled		$\pm 0.01$	$\pm 1.0$	$\mu A$
			Transmitter Enabled		$\pm 1$	$\pm 5$	$\mu A$
<b>LOGIC OUTPUTS</b>							
Output Voltage Low	$V_{OL}$	$\overline{INVALID}$ , $ROUT2B$ , $ROUT\_$	$I_{OL}=1.6mA$			0.4	V
Output Voltage High	$V_{OH}$		$I_{OH}=-1.0mA$	$V_{CC}-0.6$	$V_{CC}-0.1$		V
Output Leakage Current	$I_{OL}$	$ROUT\_$	Receivers Disabled, Connected to $V_{CC}$ or GND		$\pm 0.05$	$\pm 10$	$\mu A$

**Electrical Characteristics (Continued)**

( $V_{CC}=+3.0V$  to  $+5.5V$ ,  $C1-C4=0.1\mu F$ ,  $T_A=T_{MIN}$  to  $T_{MAX}$ , unless otherwise noted. Typical values are at  $T_A=25^\circ C$ )

Parameter	Symbol	Conditions	Min	Typ	Max	Unit	
<b>RECEIVER INPUTS</b>							
Input Voltage Range			-30		30	V	
Input Threshold Low		RIN <sub>-</sub>	$V_{CC}=3.3V$	0.8	1.15		V
			$V_{CC}=5.0V$	0.8	1.55		
Input Threshold High			$V_{CC}=3.3V$		1.35	2	V
			$V_{CC}=5.0V$		1.75	2	
Input Hysteresis	$V_{hys}$			0.2		V	
Input Resistance	$R_i$	$T_A=+25^\circ C$	3	5	7	k $\Omega$	
<b>TRANSMITTER OUTPUTS</b>							
Output Voltage Swing	$V_{OUT}$	All Transmitter Outputs Loaded with 3k $\Omega$ to Ground	$\pm 5.0$	$\pm 5.4$		V	
Output Short-Circuit Current	$I_{OS}$	Short to $V_{CC}$ , GND or Other TXD Pin	$V_{CC}=3.3V$		$\pm 20$	$\pm 40$	mA
			$V_{CC}=5.0V$		$\pm 30$	$\pm 50$	mA
Output Leakage Current	$I_{OL}$	Transmitter Disabled, Connected to V+ or V-		$\pm 1$	$\pm 10$	$\mu A$	

**Electrical Characteristics (Continued)**

( $V_{CC}=+3.0V$  to  $+5.5V$ ,  $C_1 - C_4=0.1\mu F$ ,  $T_A=T_{MIN}$  to  $T_{MAX}$ , unless otherwise noted. Typical values are at  $T_A=25^\circ C$ )

Parameter	Symbol	Conditions	Min	Typ	Max	Unit
<b>TIMING CHARACTERISTICS</b>						
Maximum Data Rate		$R_L=3k\Omega$ to $7k\Omega$ , $C_L=50pF$ to $1000pF$ , One Transmitter Switching		250		kbps
Receiver Propagation Delay	$t_{PLH}$ , $t_{PHL}$	$C_L=150pF$ Figure 4	All Parts, Normal Operation		0.15	$\mu s$
Receiver Skew	$ t_{PHL}-t_{PLH} $				0.1	$\mu s$
Receiver Output Enable Time	$t_{EN}$	$C_L=150pF$ , $R_L=3k\Omega$ Figure 5			0.2	$\mu s$
Receiver Output Disable Time	$t_{DIS}$				0.2	$\mu s$
Transmitter Propagation Delay	$t_{PLH}$ , $t_{PHL}$	$R_L=3k\Omega$ , $C_L=2500pF$ , All Transmitters Loaded Figure 3		1.3		$\mu s$
Transmitter Skew	$ t_{PHL}-t_{PLH} $				0.25	$\mu s$
Transition-Region Slew Rate	SR(tr)	$T_A=+25^\circ C$ , $V_{CC}=3.3V$ , $R_L=3k\Omega$ to $7k\Omega$ , $C_L=50pF$ to $1000pF$ , Measured from $-3V$ to $+3V$ or $+3V$ to $-3V$ , Figure 2	5	15	30	$V/\mu s$
<b>ESD AND LATCH UP PERFORMANCE</b>						
$RIN_{ESD}$ , $TOUT_{ESD}$ ESD-Protection Voltage		Human Body Model		$\pm 15$		kV
		IEC61000-4-2, Contact Discharge		$\pm 8$		
Other Pins ESD-Protection Voltage		Human Body Model		$\pm 2$		kV
Latch Up Performance		JEDEC Standard No.78D		$\pm 200$		mA

**Auto Power-Off Electrical Characteristics**

Over recommended ranges of supply voltage and operating free-air temperature (unless otherwise noted) (Figure 6)

Parameter	Symbol	Test Conditions	Min	Typ	Max	Unit
Receiver Input Positive Threshold to <u>INVALID</u> Output High	$V_{IT+(valid)}$	$\overline{FORCEON}=GND,$ $\overline{FORCEOFF}=V_{CC}$			2.7	V
Receiver Input Negative Threshold to <u>INVALID</u> Output High	$V_{IT-(valid)}$	$\overline{FORCEON}=GND,$ $\overline{FORCEOFF}=V_{CC}$	-2.7			V
Receiver Input Threshold to <u>INVALID</u> Output Low	$V_{T(invalid)}$	$\overline{FORCEON}=GND,$ $\overline{FORCEOFF}=V_{CC}$	-0.3		0.3	V
Receiver Positive or Negative Threshold to <u>INVALID</u> High	$t_{valid}$	$\overline{FORCEON}=GND,$ $\overline{FORCEOFF}=V_{CC},$ $V_{CC}=5V, \text{ Figure 6}$		1		$\mu s$
Receiver Positive or Negative Threshold to <u>INVALID</u> Low	$t_{invalid}$	$\overline{FORCEON}=GND,$ $\overline{FORCEOFF}=V_{CC},$ $V_{CC}=5V, \text{ Figure 6}$		30		$\mu s$
Receiver Edge to Charge Pump Setup	$t_{en}$	$\overline{FORCEON}=GND,$ $\overline{FORCEOFF}=V_{CC},$ $V_{CC}=5V, \text{ Figure 6}$		150		$\mu s$

## Typical Operating Characteristics

( $V_{CC}=+3.3V$ ,  $0.47\mu F$  capacitors, all transmitters loaded with  $3k\Omega$  and  $C_L$ ,  $T_A=25^\circ C$ , unless otherwise noted.)

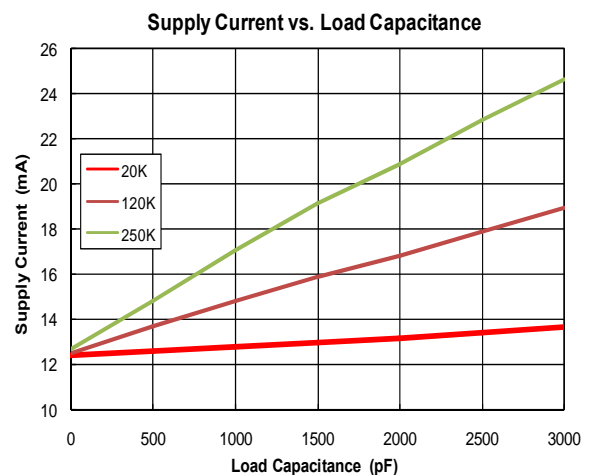
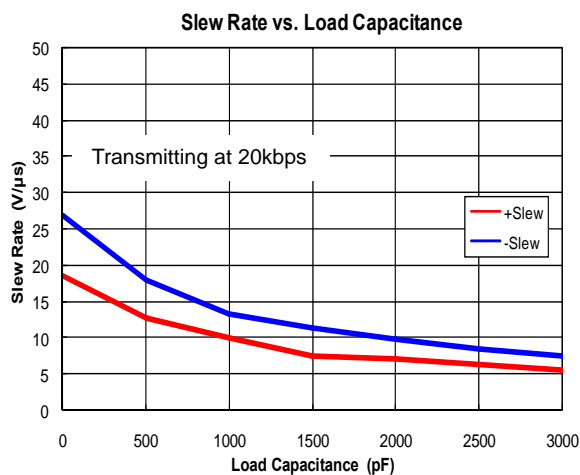
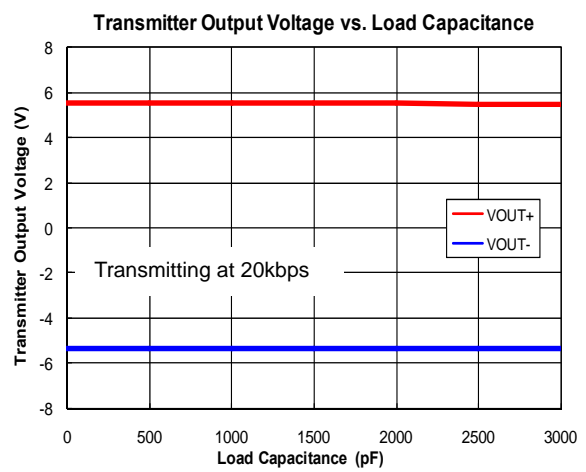
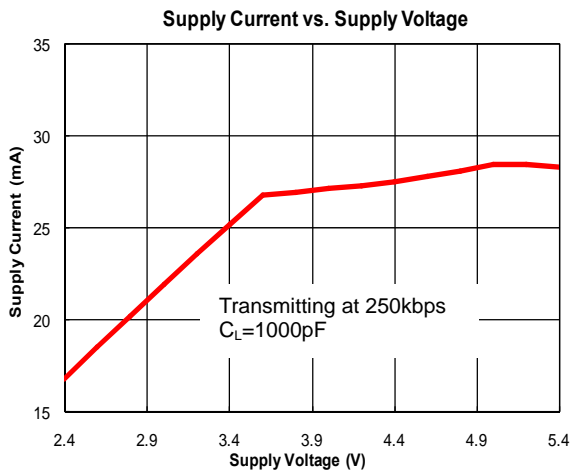
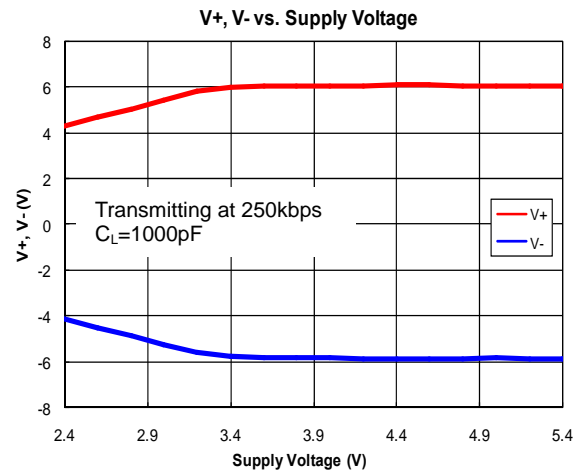
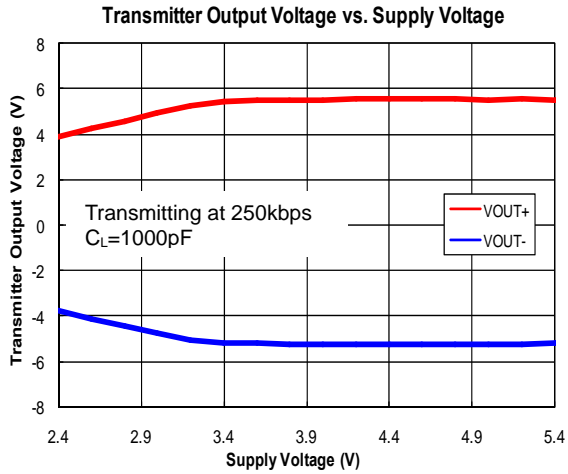

## Typical Operating Characteristics (Continued)

( $V_{CC}=+3.3V$ , 250kbps data rate,  $0.47\mu F$  capacitors, all transmitters loaded with  $5k\Omega$  and  $C_L$ ,  $T_A=25^\circ C$ , unless otherwise noted.)

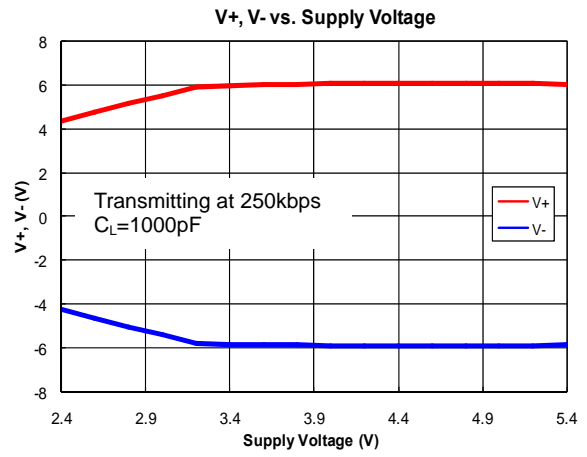
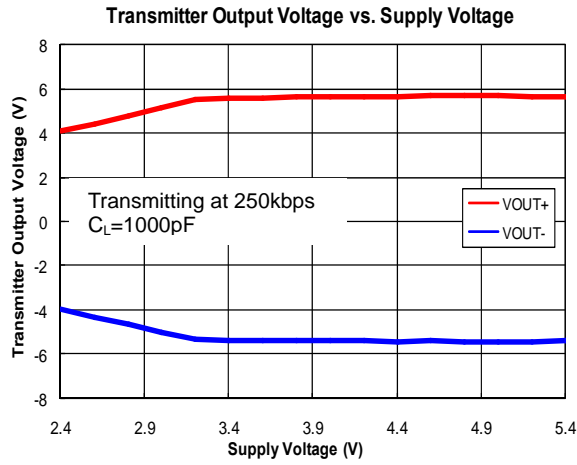

**Function Tables**
**Table 1. Each Transmitter (Note 2)**

INPUTS				OUTPUT	TRANSMITTER STATUS
TIN	FORCEON	$\overline{\text{FORCEOFF}}$	VALID RIN RS-232 LEVEL	TOUT	
X	X	L	X	Z	Forced Power-Off
L	H	H	X	H	Normal Operation with Forced Power-On
H	H	H	X	L	
L	L	H	Yes	H	Normal Operation with Auto Power-On
H	L	H	Yes	L	
X	L	H	No	Z	Auto Power-Off

Note 2: H=high level, L=low level, X=irrelevant, Z=high impedance

**Table 2. Each Receiver (Note 3)**

INPUTS			OUTPUT	RECEIVER STATUS
RIN	FORCEON	$\overline{\text{FORCEOFF}}$	ROUT	
X	X	L	Z	Forced Power-Off
L	X	H	H	Normal Operation
H	X	H	L	
Open	X	H	H	

**Table 3. ROUT2B and Outputs  $\overline{\text{INVALID}}$  (Note 3)**

INPUTS				OUTPUTS		OUTPUT STATUS
VALID RIN RS-232 LEVEL	RIN2	FORCEON	$\overline{\text{FORCEOFF}}$	$\overline{\text{INVALID}}$	ROUT2B	
Yes	L	X	X	H	L	Always Active
Yes	H	X	X	H	H	
Yes	Open	X	X	H	L	
No	Open	X	X	L	L	

Note 3: H=high level, L=low level, X=irrelevant, Z=high impedance (off), Open=input disconnected or connected driver off

**Logic Diagram**

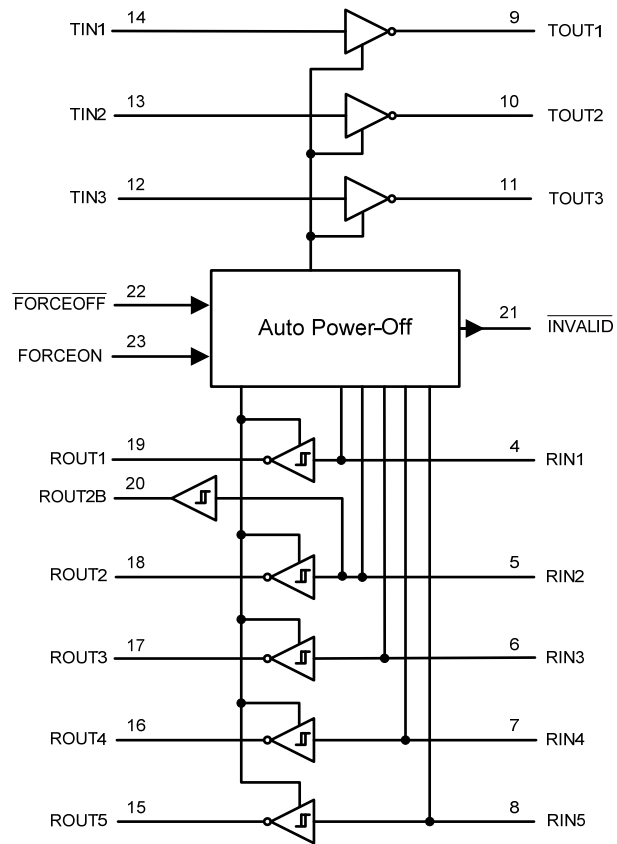

**Figure 1**

**Parameter Measurement Information**

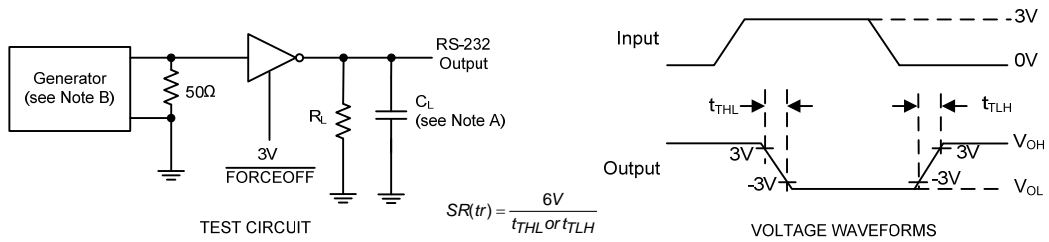

NOTES: A.  $C_L$  includes probe and jig capacitance.  
B. The pulse generator has the following characteristics:  $Z_o=50\Omega$ , 50% duty cycle,  $t_r \leq 10ns$ ,  $t_f \leq 10ns$ .

**Figure 2. Transmitter Slew Rate**

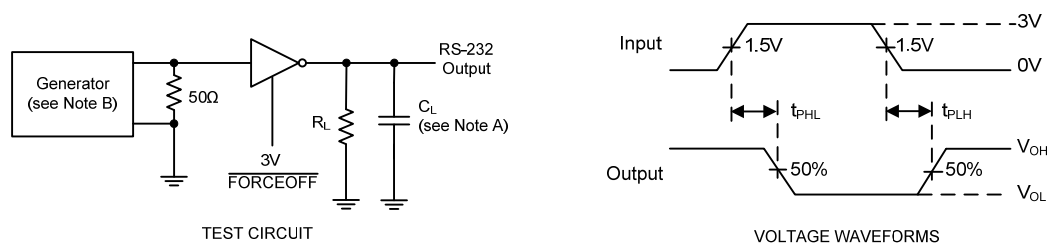

NOTES: A.  $C_L$  includes probe and jig capacitance.  
B. The pulse generator has the following characteristics: PRR=250kbit/s,  $Z_o=50\Omega$ , 50% duty cycle,  $t_r \leq 10ns$ ,  $t_f \leq 10ns$ .

**Figure 3. Transmitter Pulse Skew**

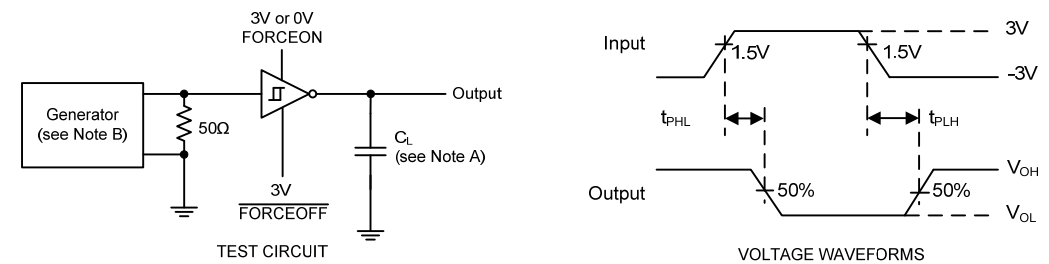

NOTES: A.  $C_L$  includes probe and jig capacitance.  
B. The pulse generator has the following characteristics:  $Z_o=50\Omega$ , 50% duty cycle,  $t_r \leq 10ns$ ,  $t_f \leq 10ns$ .

**Figure 4. Receiver Propagation Delay Times**

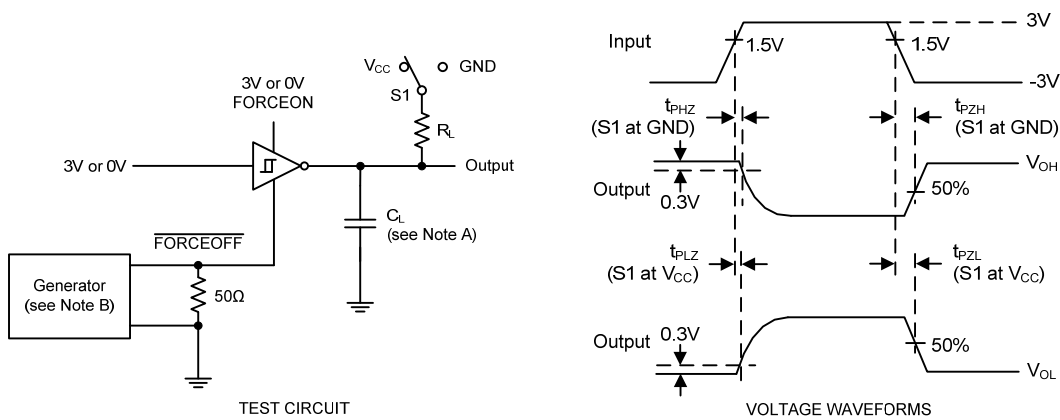

NOTES: A.  $C_L$  includes probe and jig capacitance.  
B. The pulse generator has the following characteristics:  $Z_o=50\Omega$ , 50% duty cycle,  $t_r \leq 10ns$ ,  $t_f \leq 10ns$ .  
C.  $t_{PLZ}$  and  $t_{PHZ}$  are the same as  $t_{dis}$ .  
D.  $t_{PZL}$  and  $t_{PZH}$  are the same as  $t_{en}$ .

**Figure 5. Receiver Enable and Disable Times**

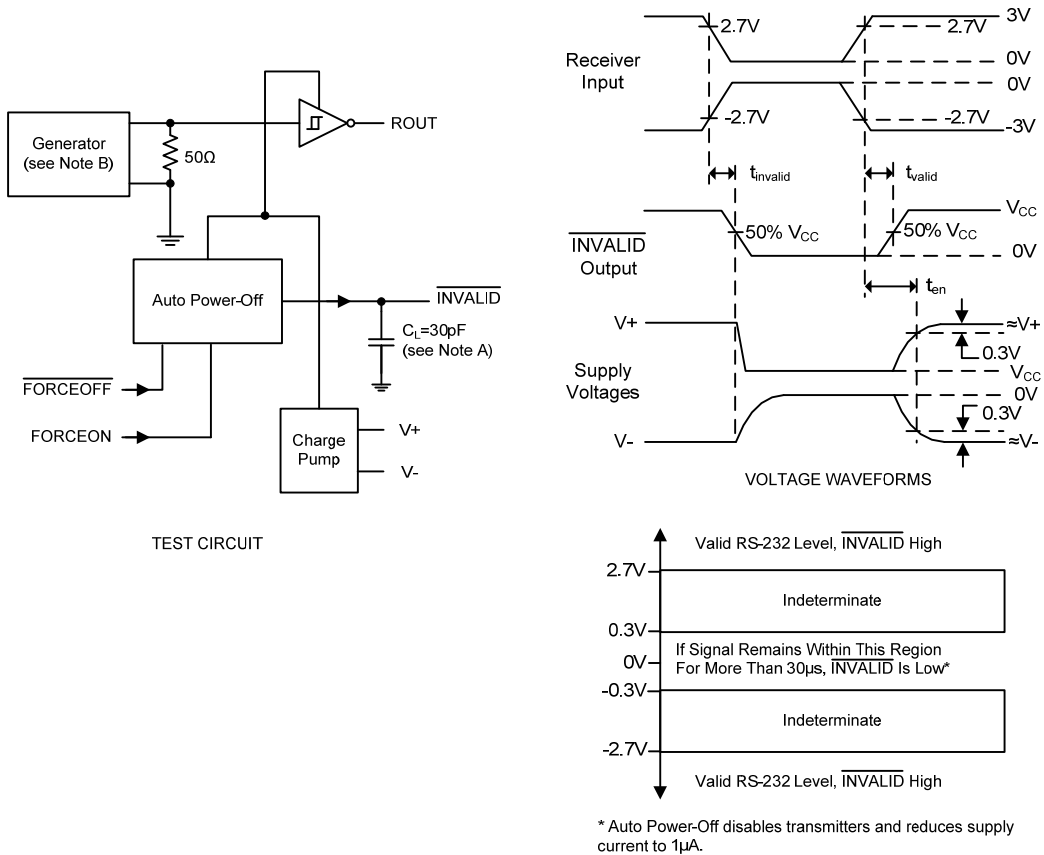

NOTES: A. C<sub>L</sub> includes probe and jig capacitance.

B. The pulse generator has the following characteristics: PRR=5kbit/s, Z<sub>O</sub>=50Ω, 50% duty cycle, t<sub>r</sub>≤10ns, t<sub>f</sub>≤10ns.

**Figure 6. INVALID Propagation Delay Times and Supply Enabling Time**

## Typical Operating Circuits

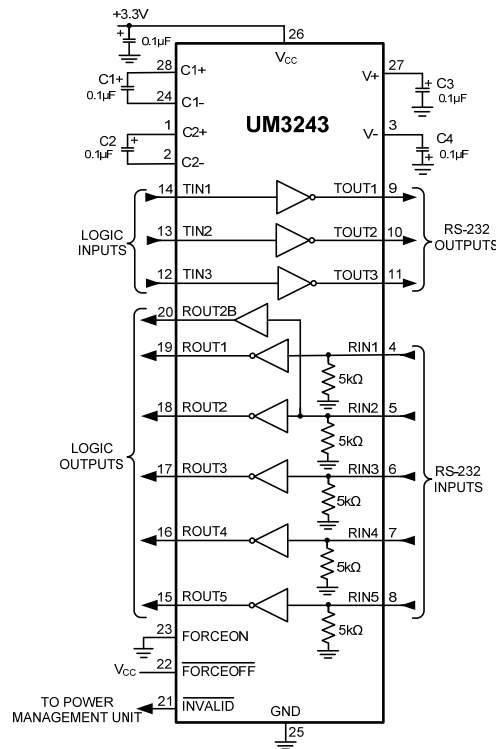

Figure 7

## Application Information

### RS-232 Receivers

The UM3243's receivers convert RS-232 signals to CMOS-logic output levels. All receivers have inverting three-state outputs and can be active or inactive. The UM3243's receivers are high-impedance when the part is in Forced Power-Off mode ( $\overline{\text{FORCEOFF}} = \text{low}$ ).

The UM3243 features an always-active complementary output (ROUT2B). ROUT2B monitors receiver activity while the other receivers are high-impedance. This allows Ring Indicator to be monitored without forward biasing other devices connected to the receiver outputs. This is ideal for systems where  $V_{CC}$  drops to 0 in Power-Off to accommodate peripherals such as UARTs (Figure 8).

The UM3243 features an  $\overline{\text{INVALID}}$  output that is enabled low when no valid RS-232 signal levels have been detected on all receiver inputs.  $\overline{\text{INVALID}}$  is functional in any mode (Figure 6).

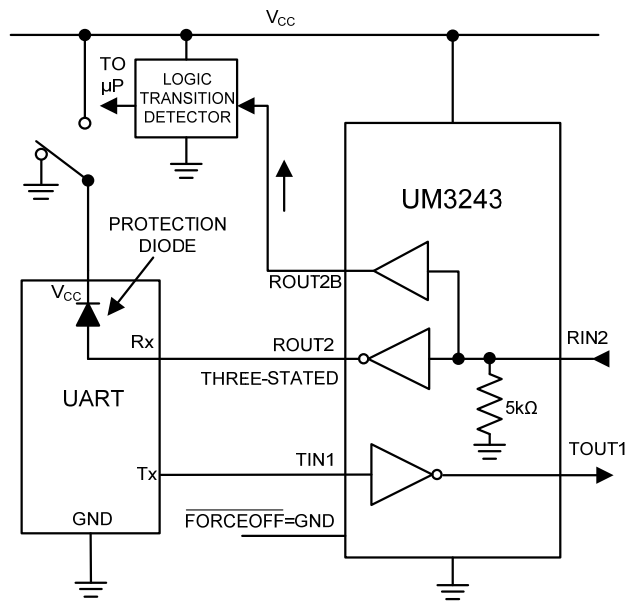

UM3243: In Power-Off, ROUT2B is used to monitor external devices and ROUT2 is three-stated, eliminating a current path through the UART's protection diode.

**Figure 8. The UM3243 detects RS-232 activity when the UART and interface are powered off.**

**Auto Power-Off and Wakeup**

The UM3243 achieves a 0.1µA supply current Auto Power-Off feature, which operates when FORCEON is low and FORCEOFF is high. When the device senses no valid signal levels on all receiver inputs for  $t_{invalid}$  time (typically 30µs), the onboard charge pump and drivers are powered off, reducing supply current to 0.1µA. This occurs if the RS-232 cable is disconnected or the connected peripheral transmitters are turned off. The device turns on again when a valid level is applied to any RS-232 receiver input for  $t_{valid}$  time (typically 1µs). The charge pump will set up after  $t_{en}$  time (typically 150µs). As a result, the system saves power without changes to the existing system.

Table 3 and Figure 9 summarize the UM3243 operating modes. FORCEON and FORCEOFF override Auto Power-Off. When neither control is asserted, the IC will select between these states automatically, based on receiver input levels. Figure 6 depicts valid and invalid RS-232 receiver levels and timing diagram for Auto Power-Off operation.

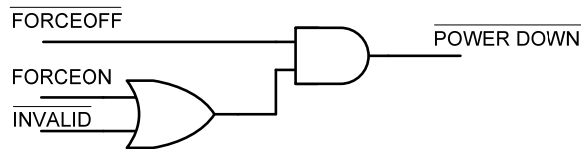

INVALID is an internally generated signal that is used by the Auto Power-Off logic and appears as an output of the device.

POWER DOWN is only an internal signal. It controls the operational status of the transmitters and the power supplies.

**Figure 9. UM3243 Auto Power-Off Logic**

## RS-232 Transmitters

The transmitters are inverting level translators that convert CMOS-logic levels to EIA/TIA-232 levels. They guarantee a 250kbps data rate with worst-case loads of 3kΩ in parallel with 1000pF, providing compatibility with PC-to-PC communication software. Transmitters can be paralleled to drive multiple receivers. In Power-Off mode (See Table 1), the transmitters are disabled and the outputs are forced into a high-impedance state.

## Dual Charge Pump Voltage Converter and Capacitor Selection

The UM3243's internal power supply consists of a regulated dual charge pump that provides output voltages of +6V (doubling charge pump) and -6V (inverting charge pump), over the +3.0V to +5.5V  $V_{CC}$  range. The charge pump operates in discontinuous mode: if the output voltage is less than 6V, the charge pump is enabled; if the output voltage exceeds 6V, the charge pump is disabled. The charge pump requires a flying capacitor (C1, C2) and a reservoir capacitor (C3, C4) to generate the V+ and V- supplies.

The capacitor type used for C1–C4 is not critical for proper operation; either polarized or non-polarized capacitors may be used. The charge pump requires 0.1μF capacitors for 3.3V operation. For other supply voltages, refer to Table 4 for required capacitor values. Do not use values smaller than those listed in Table 4. Increasing the capacitor values (e.g., by a factor of 2) reduces ripple on the transmitter outputs and slightly reduces power consumption. When using the minimum required capacitor values, make sure the capacitor value does not degrade excessively with temperature. If in doubt, use capacitors with a larger nominal value. The capacitor's equivalent series resistance (ESR) usually rises at low temperatures and influences the amount of ripple on V+ and V-.

**Table 4. Required Capacitor Values**

$V_{CC}$ (V)	C1, C2, C3, C4 (μF)
3.15 to 3.6	0.1
4.5 to 5.5	0.1
3.0 to 5.5	0.47
2.4 to 3.0	0.47

## High Data Rates

The UM3243 maintains the RS-232 ±5.0V minimum transmitter output voltage even at high data rates. Figure 10 shows a transmitter loopback test circuit. Figure 11 shows a loopback test result at 120kbps, and Figure 12 shows the same test at 250kbps. For Figure 11, all three transmitters were driven simultaneously at 120kbps into RS-232 loads in parallel with 1000pF. For Figure 12, a single transmitter was driven at 250kbps, and all three transmitters were loaded with an RS-232 receiver in parallel with 1000pF.

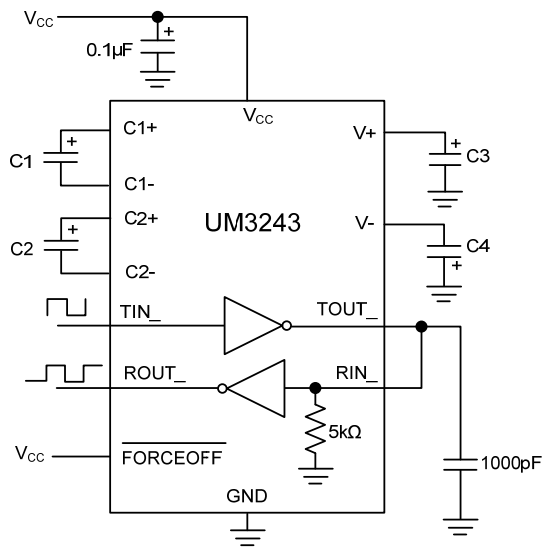

**Figure 10. Loopback Test Circuit**

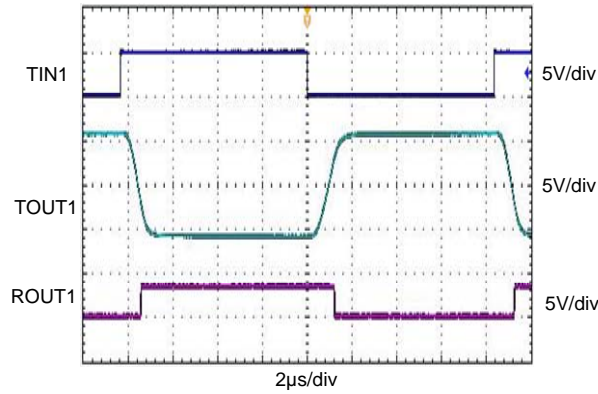

**Figure 11. Loopback Test Result at 120kbps**

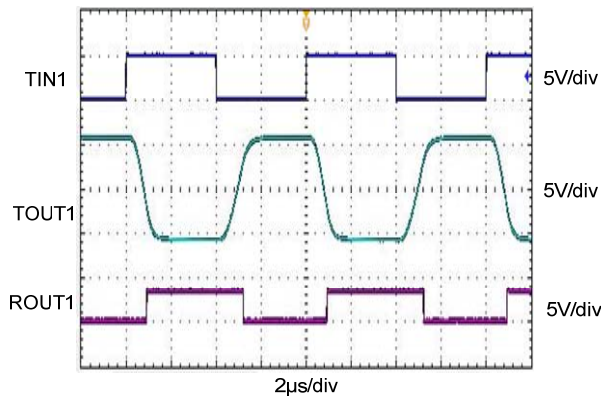
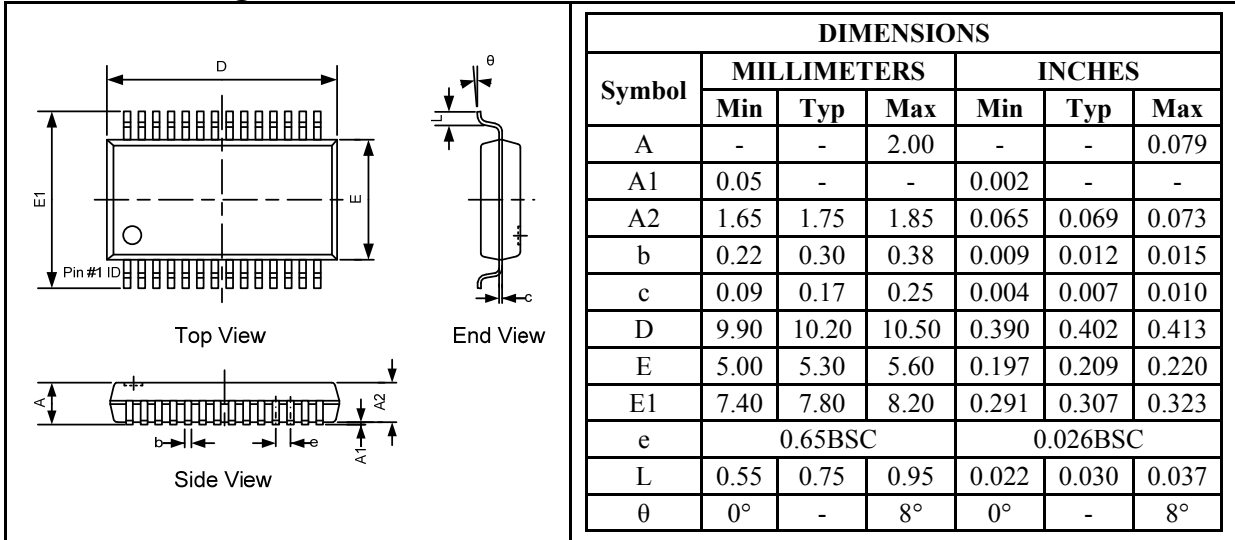

**Figure 12. Loopback Test Result at 250kbps**

## Package Information

### UM3243EEAS: SSOP28

#### Outline Drawing



#### Land Pattern

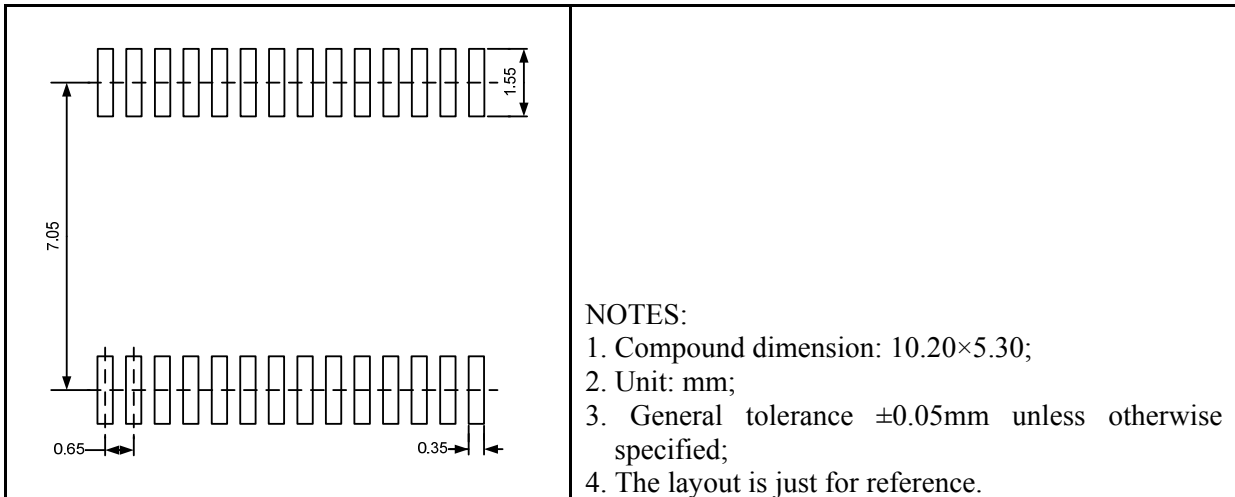

## UM3243EEASR: SSOP28

### Outline Drawing

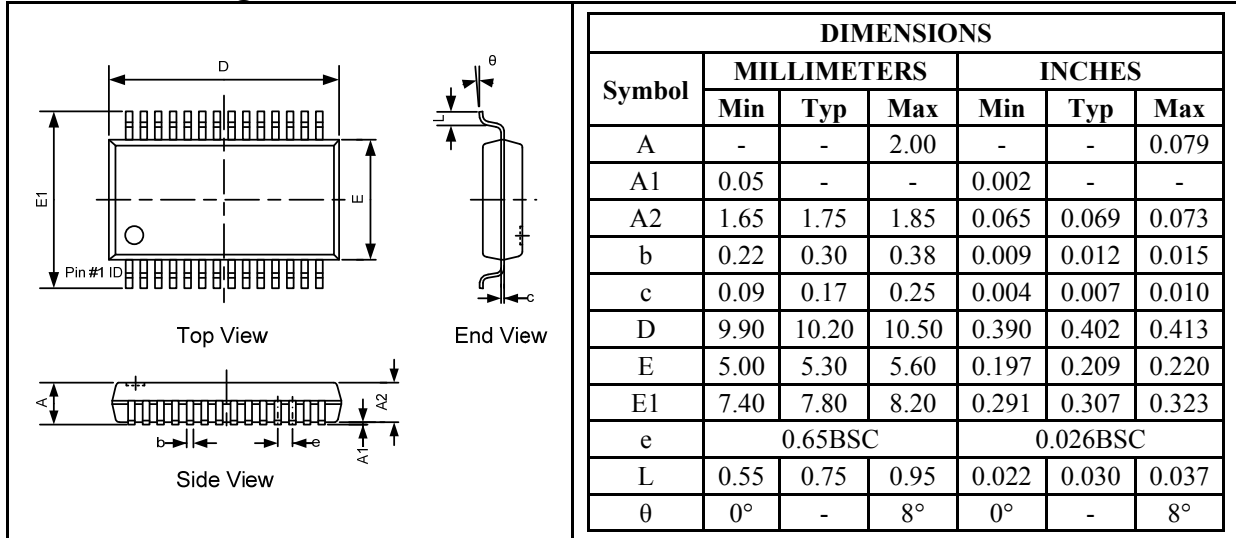

### Land Pattern

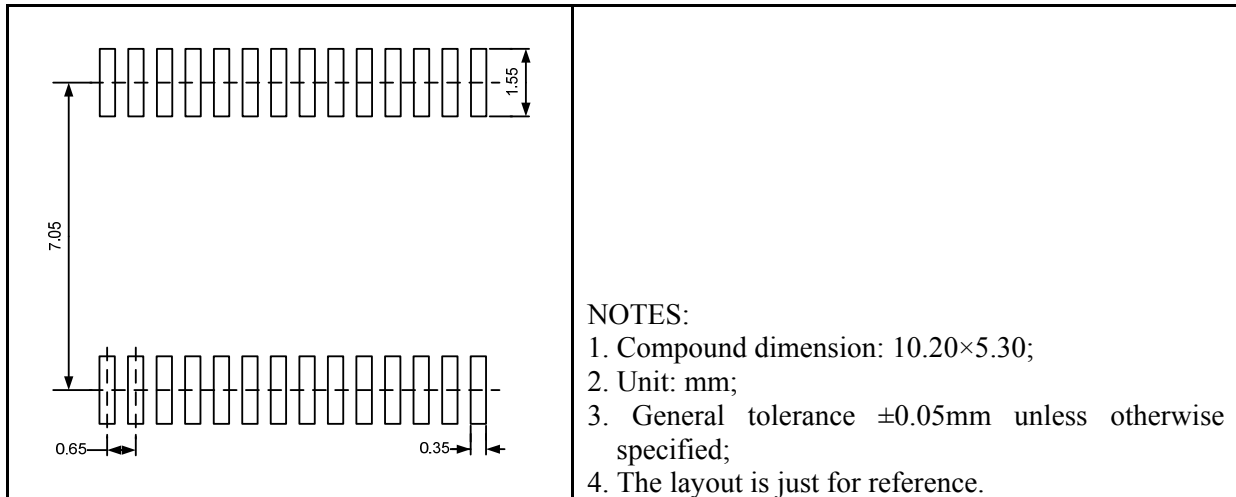

### Tape and Reel Orientation



## UM3243EEUS: TSSOP28

### Outline Drawing

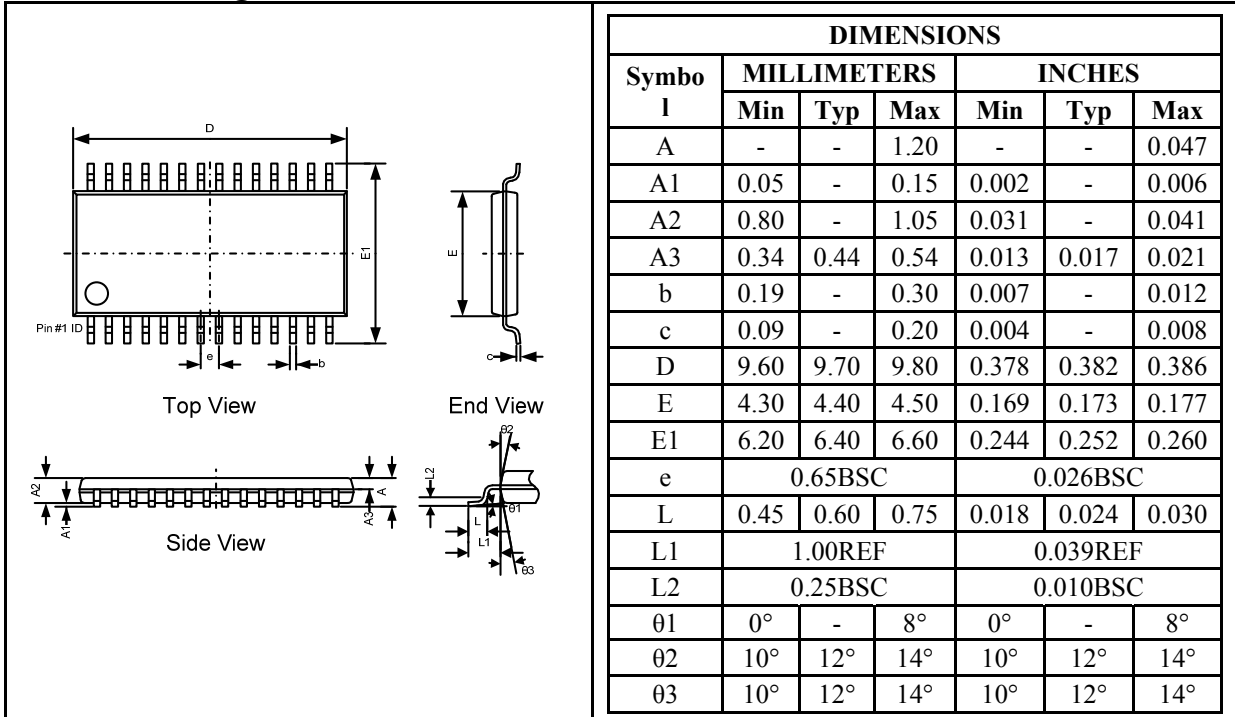

### Land Pattern

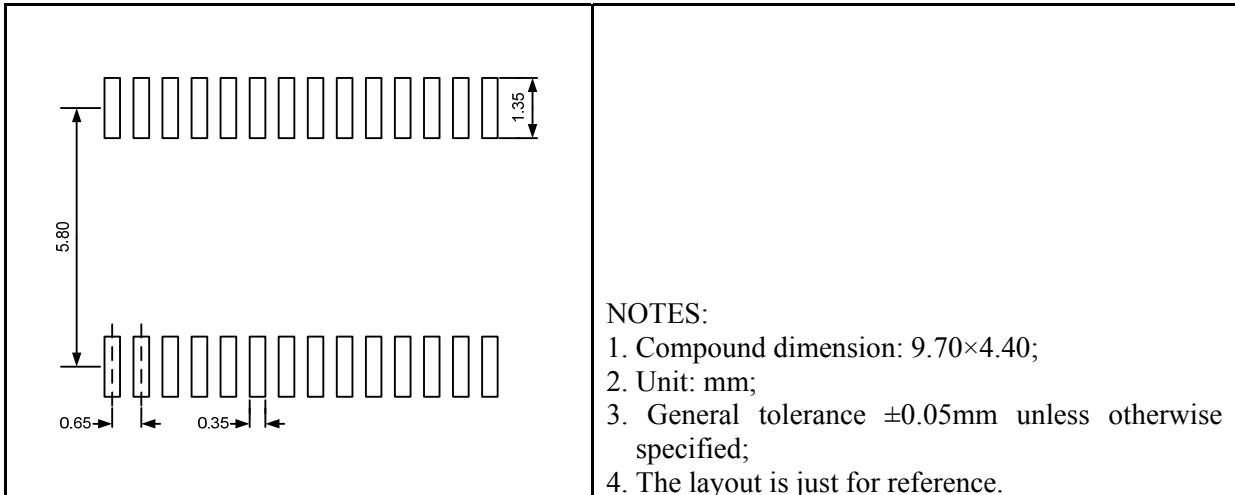

### Tape and Reel Orientation

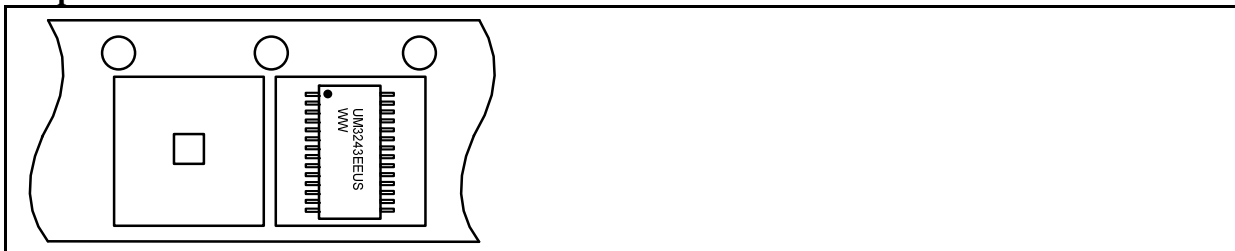

## UM3243EESS: SOP28

### Outline Drawing

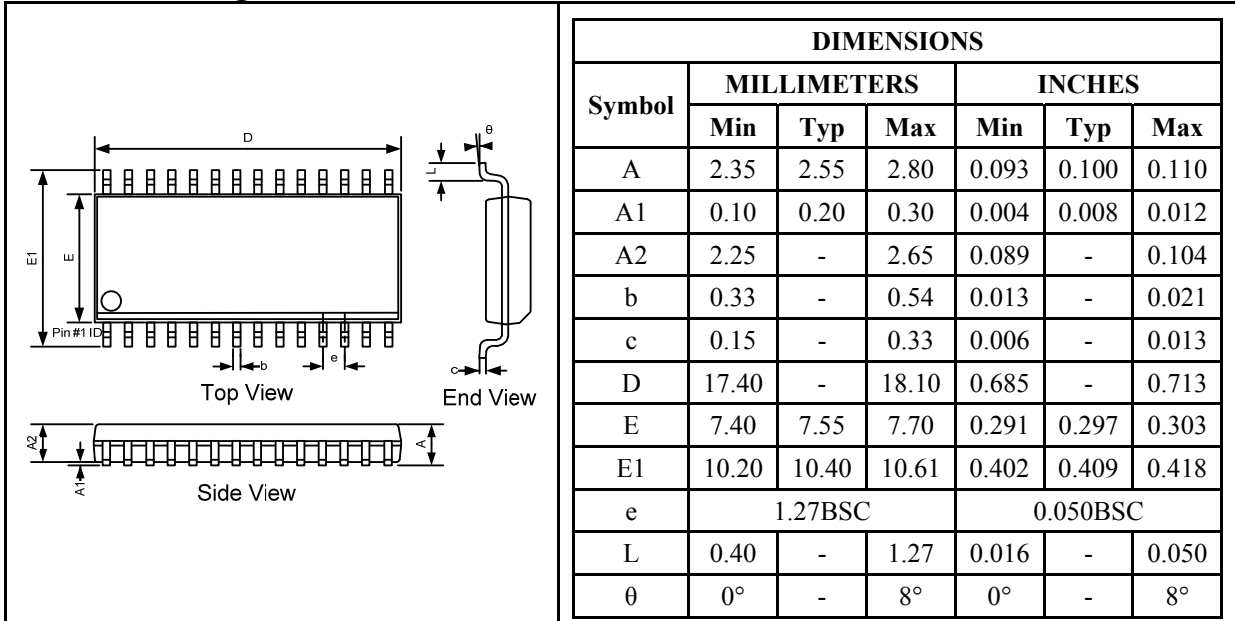

### Land Pattern

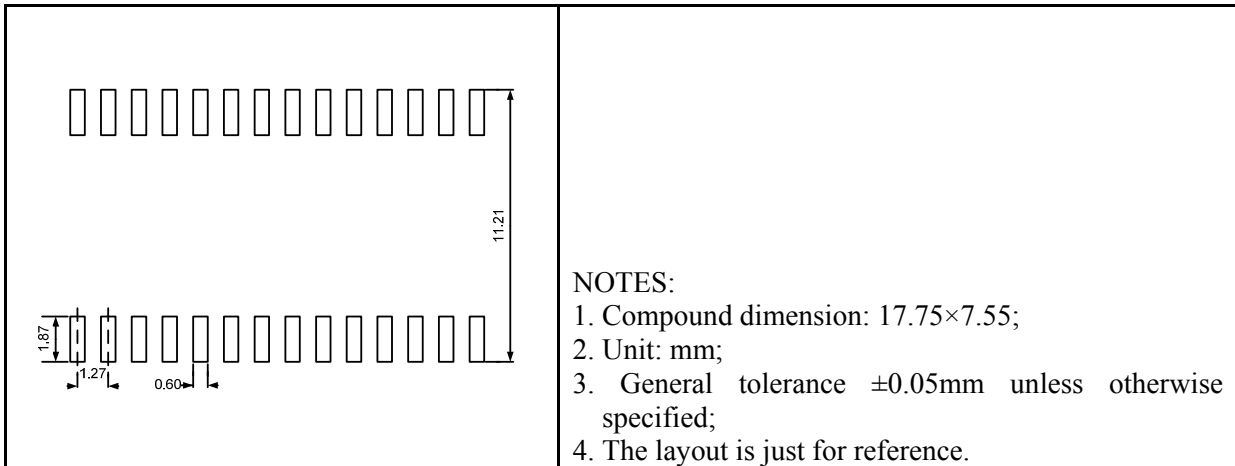



---

## **GREEN COMPLIANCE**

Union Semiconductor is committed to environmental excellence in all aspects of its operations including meeting or exceeding regulatory requirements with respect to the use of hazardous substances. Numerous successful programs have been implemented to reduce the use of hazardous substances and/or emissions.

All Union components are compliant with the RoHS directive, which helps to support customers in their compliance with environmental directives. For more green compliance information, please visit:

[http://www.union-ic.com/index.aspx?cat\\_code=RoHSDeclaration](http://www.union-ic.com/index.aspx?cat_code=RoHSDeclaration)

## **IMPORTANT NOTICE**

The information in this document has been carefully reviewed and is believed to be accurate. Nonetheless, this document is subject to change without notice. Union assumes no responsibility for any inaccuracies that may be contained in this document, and makes no commitment to update or to keep current the contained information, or to notify a person or organization of any update. Union reserves the right to make changes, at any time, in order to improve reliability, function or design and to attempt to supply the best product possible.



Union Semiconductor, Inc

Add: Unit 606, No.570 Shengxia Road, Shanghai 201210

Tel: 021-51093966

Fax: 021-51026018

Website: [www.union-ic.com](http://www.union-ic.com)

## Looking for pricing, stock, or lifecycle information?

Click below to explore more details on WIN SOURCE:

- ⊖ [View UM3243EEASR](#) on WIN SOURCE
- ⊖ [Union Semiconductor](#) Information

## Optimize Your Supply Chain with WIN SOURCE Solutions

- ✓ Global Sourcing Solution
- ✓ Obsolete Management
- ✓ Cost Control Management
- ✓ Shortage Management
- ✓ Alternative Solution
- ✓ Excess Inventory Management